

WI Line

WIC1

SELF-/DUAL-POWERED PROTECTION DEVICE

- WIC1-1 | Self-powered device, parameter settings via Smart view (PC) / DigiMEC
- WIC1-2 | Self-powered device, parameter settings via DIP switches and/or Smart view (PC) / DigiMEC
- WIC1-3 | Self-powered device, parameter settings via HEX switches and/or Smart view (PC) / DigiMEC
- WIC1-4 | Dual-powered device, parameter settings via Smart view (PC) / DigiMEC

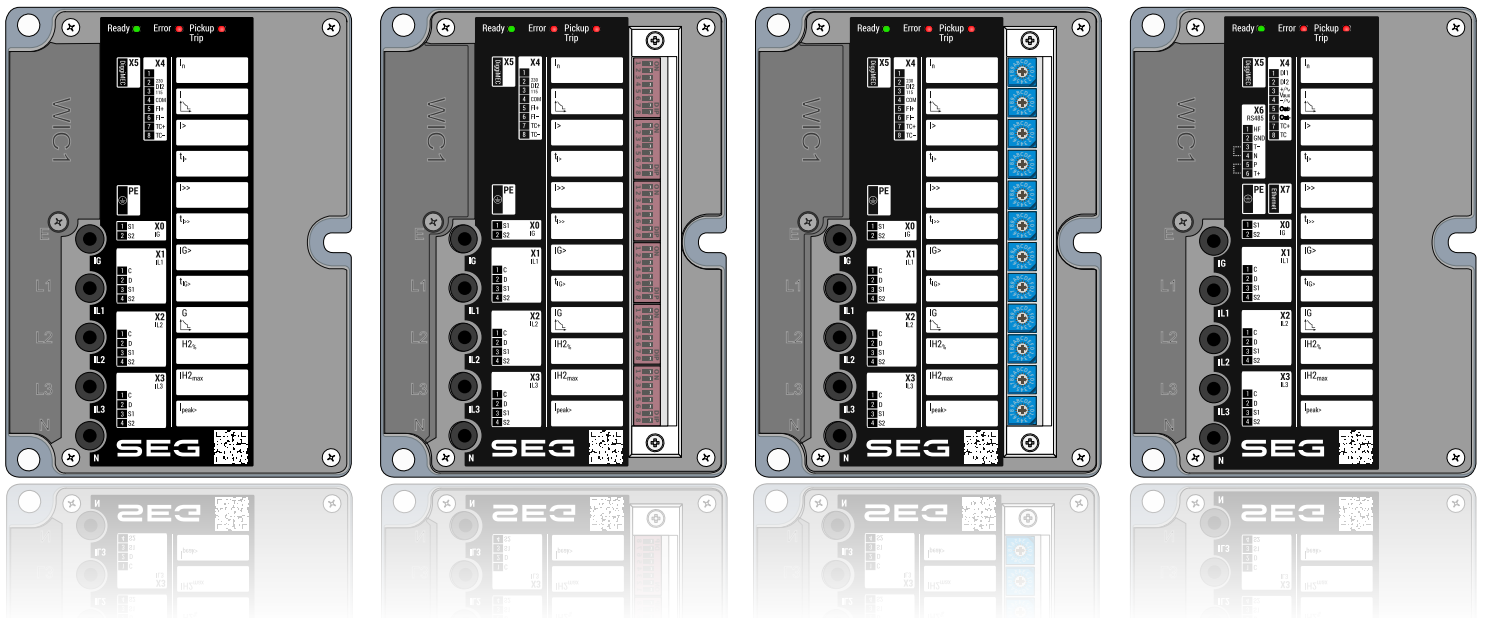

SELF-/DUAL-POWERED PROTECTION DEVICE

DM version: 2.3

Original document

English

MANUAL WIC1-2.3-EN-MAN

Build 66953

Revision B

© 2026 SEG Electronics GmbH. All rights reserved.

SEG Electronics GmbH

Krefelder Weg 47 • D-47906 Kempen (Germany)

Telephone: +49 (0) 21 52 145 0

Internet: www.SEGelectronics.de

Sales

Telephone: +49 (0) 21 52 145 331

Fax: +49 (0) 21 52 145 354

E-mail: sales@SEGelectronics.de

Service

Telephone: +49 (0) 21 52 145 600

Fax: +49 (0) 21 52 145 354

E-mail: support@SEGelectronics.de

SEG Electronics GmbH reserves the right to update any portion of this publication at any time.

Information provided by SEG Electronics GmbH is believed to be correct and reliable.

However, no responsibility is assumed by SEG Electronics GmbH unless otherwise expressly undertaken.

Complete address / phone / fax / email information for all locations is available on our website.

WIC1 Functional Overview

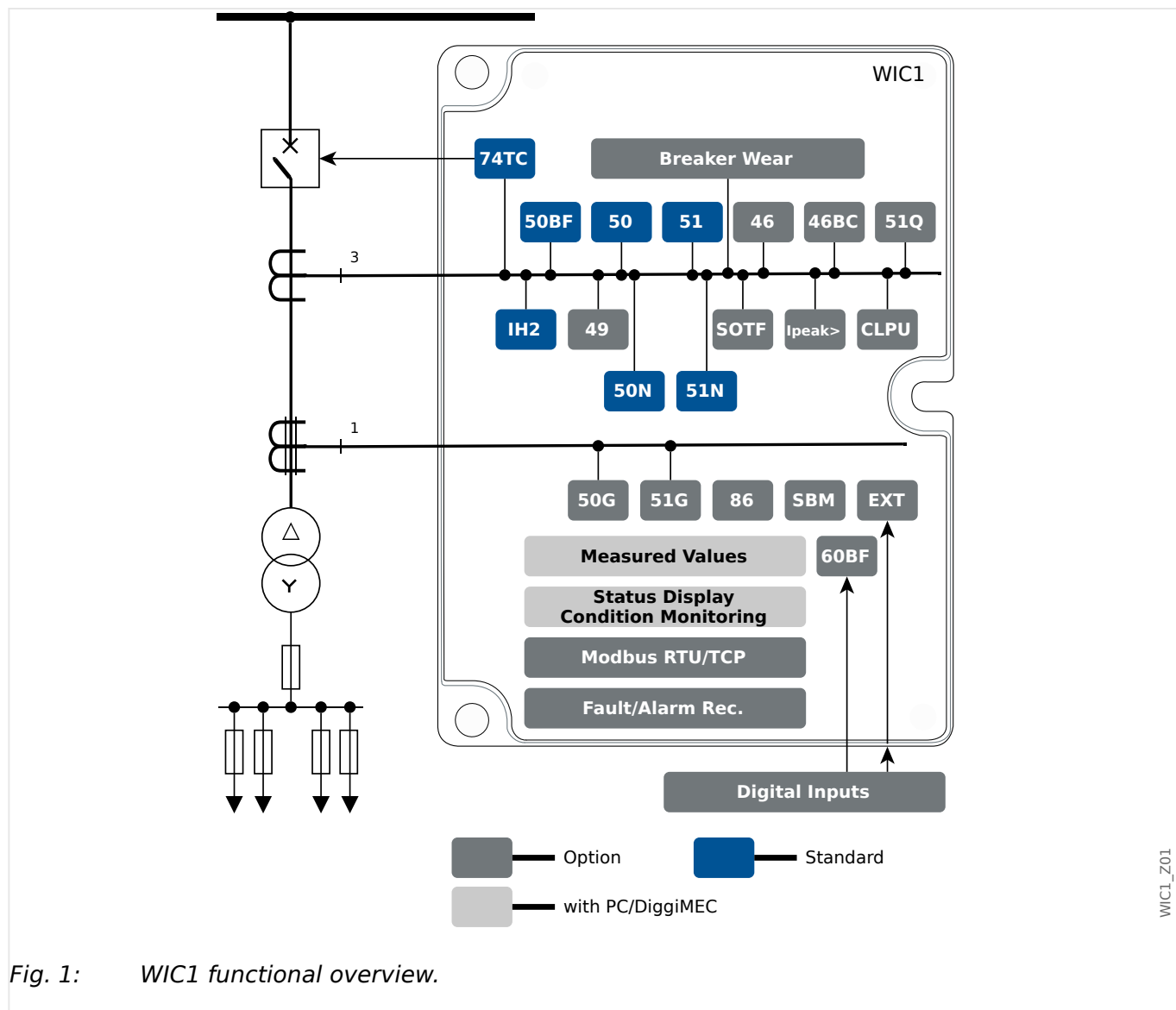

Fig. 1: WIC1 functional overview.

- [Details](#)
- [Introduction](#)
- [Operation Concepts](#)
- [Hardware, Wiring, Dimension Diagrams](#)
- [Overview DIP switches](#)
- Separate documents:
 - Reference Manual (All parameters that can be used via *DiggiMEC/Smart view*)
 - Wiring Diagrams (terminals and wiring for each device variant)
- [Order Form\(s\)](#)

Table of Contents

1	Safety Messages and Proper Use of the WIC1	13
1.1	Important Definitions	13
1.2	Proper Use of the Device and of This Manual	14
1.3	Personal Safety	17
1.4	Important Information	18
2	WIC1 - Introduction, Operation	19
2.1	Basic Wiring Concept	21
2.2	Settings - Change Device Parameters	23
2.2.1	PC via Smart view and DiggiMEC (HMI)	23
2.2.1.1	Smart view	24
2.2.2	Validity of the DIP-/HEX-Switches	25
2.3	Supply of a WIC1	27
2.4	WIC1 Protection Features	28
2.4.1	Functional Overview	28
2.4.2	Device Features	29
2.5	Comments on the Manual	31
2.5.1	Symbols in Function Diagrams	32
2.6	Information About the Device	35
2.6.1	Order Forms	36
2.6.1.1	Order Form of the CT-Powered Device Types	38
2.6.1.2	Order Form of the Dual-Powered WIC1-4	40
2.6.1.3	Order Form of the WIC1-Compatible Current Transformers	42
2.6.1.4	Order Form WI1SZ4	43
2.6.1.5	Order Form WI1SZ5	43
2.6.1.6	Order Form of the PC4 adapter	44
2.6.1.7	Order Form of the DiggiMEC	44
2.7	Device Planning	45
2.8	Modules, Settings, Signals and Values	47
2.9	Measuring Values	49
2.10	Condition Monitoring (Peak Current Ptr, Life Load)	51

2.11	Reset	52
2.11.1	Automatic Reset	53
2.11.2	Notification of a Problem via LED	54
2.12	Reset to Factory Defaults	55
2.13	Security	56
2.13.1	Password	56
2.14	Date and Time, Counters	57
3	Hardware	58
3.1	Overview of Elements and Connectors	58
3.1.1	Terminals, Screws and Torques	61
3.1.2	Grounding	62
3.1.2.1	Nut “PE” for Grounding	63
3.2	Dimension Drawings	64
3.2.1	WIC1 Dimension Drawings	64
3.2.2	DiggiMEC Dimension Drawings	66
3.2.3	Dimension Drawings of the WIC1-Compatible Current Transformers	68
3.2.4	Dimension Drawing of the Flag Indicators WI1SZ4, WI1SZ5	73
3.3	Current Transformers (CTs)	74
3.3.1	WIC1-Wx CTs (Primary Measurement)	77
3.3.1.1	Current Ranges of the WIC1-Wx-CTs	77
3.3.1.2	Selection of the CT Transformation Voltage Ratio	77
3.3.1.3	CT Type WE2	79
3.3.2	WIC1-WC Converter CTs (1 A / 5 A Measurement)	80
3.3.2.1	Requirements for Standard CTs	82
3.4	Phase and Ground Current Measuring Inputs	84
3.4.1	Current Measuring Inputs for WIC1-CTs and Without Ground Current Input	86
3.4.2	Current Measuring Inputs for WIC1-CTs With Ground Current Input	87
3.5	Digital Input (only WIC1-1... / WIC1-2... / WIC1-3...)	88
3.6	Additional Power Supply and Digital Inputs (WIC1-4... only)	89
3.7	Serial Interface RS485 (WIC1-4... only)	91
3.8	Ethernet Interface (RJ45)	95
3.9	Ethernet / TCP/IP via Fiber Optics	96

3.10	Outputs (Trip Coil, Flag Indicator, Relay Output)	97
3.10.1	Self-Supervision Contact for the WIC1-4	100
3.10.2	Connecting a Flag Indicator to the WIC1	101
3.10.3	Impulse Signal for the Flag Indicator	103
3.11	LEDs	104
3.11.1	WIC1-LED for “Pickup / TripCmd”	107
3.11.2	LED Configuration (DiggiMEC)	107
3.11.3	Latching of the DiggiMEC LEDs	107
3.11.4	Latching of a DiggiMEC-LED with an Assigned Trip Signal	108
3.12	PC4 adapter – PC Interface for WIC1	110
3.13	DiggiMEC® – Nano HMI with optional Flag Indicators and Output Relays	112
3.13.1	Navigation – Operation	114
3.13.1.1	Front Panel Parts	114
3.13.1.2	Favorites Key »★«	117
3.13.1.3	Special Keys During Power-on	119
3.13.1.4	Menu Structure	120
3.13.1.5	Parameter Changes – “OK” key	122
3.13.2	DiggiMEC Connectors	125
3.13.3	Flag Indicator / Output Relays Settings (DiggiMEC)	130
3.13.3.1	Latching	131
3.13.3.2	Testing the Flag Indicators / Output Relays	132
3.13.4	Default Setting LEDs & Flag Indicators / Output Relays	133
4	Communication Protocols (WIC1-4 only)	134
4.1	TCP/IP Settings	135
4.2	Modbus® (WIC1-4 only)	136
5	Protective Elements	139
5.1	»Prot« – General Protection Module	139
5.1.1	General Pickup, General Alarm, General Trip	141
5.1.1.1	Trip Pulse and WIC1 LEDs	142
5.1.1.2	Phase-Selective Signals, Collective Signals	144
5.1.2	Force Trip Command	146
5.1.3	Blockings	147

5.1.3.1	Switching Protection Functions On or Off	147
5.1.3.2	Temporary Blocking	148
5.1.4	Control of a Switchgear	149
5.1.4.1	Switch ON Command (external)	149
5.1.4.2	Switchgear Position	149
5.2	Field Parameters	155
5.2.1	Field Parameter Settings via Smart view (PC) or DiggiMEC	155
5.3	I>, I>>, I>>> - Phase Overcurrent Protection [50, 51]	157
5.3.1	Functionality	158
5.3.2	Phase Overcurrent Protection - Settings	160
5.3.2.1	Phase Overcurrent Protection - Settings via Smart view (PC) or DiggiMEC	161
5.4	IH2 - Inrush Blocking	163
5.4.1	Functionality	164
5.4.2	Inrush - Settings	165
5.4.2.1	Inrush - Settings via Smart view (PC) or DiggiMEC	165
5.4.3	Commissioning: Inrush	166
5.5	IG>, IG>> - Earth (Ground) Overcurrent Protection [50N/G, 51N/G]	167
5.5.1	Functionality	168
5.5.2	Earth (Ground) Overcurrent Protection - Settings	169
5.5.2.1	Earth (Ground) Overcurrent Protection - Settings via Smart view (PC) or DiggiMEC	170
5.5.3	Earth (Ground) Overcurrent Protection - Measuring Method	172
5.6	I2/I1> - Unbalanced Load [46]	174
5.6.1	Functionality	175
5.6.2	Current Unbalance Protection - Settings via Smart view (PC) or DiggiMEC	176
5.7	I2> - Negative-Sequence Current Protection [51Q]	177
5.7.1	Functionality	178
5.7.2	Settings via Smart view (PC) or DiggiMEC	179
5.8	ThR - Thermal Overload [49]	181
5.8.1	Functionality	182
5.8.2	Thermal Overload - Settings via Smart view (PC) or DiggiMEC	183
5.9	Ipeak> - Peak Overcurrent Protection	184
5.9.1	Functionality	185

5.9.2	Ipeak> – Settings	186
5.9.2.1	Ipeak> – Settings via Smart view (PC) or DiggiMEC	186
5.10	SOTF - Switch Onto Fault	187
5.10.1	SOTF – Settings via Smart view (PC) or DiggiMEC	189
5.11	CLPU - Cold Load Pickup (WIC1-4 only*)	190
5.11.1	Functionality	192
5.11.2	CLPU – Settings via Smart view (PC) or DiggiMEC	192
5.12	ExP – External Protection	194
5.12.1	Functionality	195
5.12.2	External Protection – Settings via Smart view (PC) or DiggiMEC	196
5.13	CBF – Circuit Breaker Failure [50BF, 62BF]	197
5.13.1	Principle – General Use	197
5.13.2	States / Standby	198
5.13.3	Functionality	198
5.14	Supervision	199
5.14.1	BkrWear	199
5.14.1.1	BkrWear – Settings via Smart view (PC) or DiggiMEC	201
5.14.1.2	Functionality	203
5.14.2	»TCM« – Trip Circuit Monitoring [74TC]	204
5.14.3	Condition Monitoring – Life Load	205
5.14.4	Condition Monitoring – Peak Current Pointer	207
5.14.5	Condition Monitoring – Station Battery Monitoring (WIC1-4 only*)	208
5.14.5.1	Alarm/Trip Functionality of the SBM module	209
6	Fault/Alarm Recorder	210
6.1	Fault/Alarm Display	212
6.2	Content of a Fault/Alarm Record	214
6.3	How to Read Out the Fault Recorder at the DiggiMEC Panel	215
7	Self-Supervision	216
7.1	Device Start (Reboot)	217
7.2	Self-Supervision Messages	218
7.3	Backup Protection / Self-Supervision	220
7.3.1	Activation of the Backup Protection / Self-Supervision Mode	222

8	Commissioning	223
8.1	Commissioning / Protection Test	224
8.1.1	Special Features of the WIC1 Test	225
8.1.2	Selection of the Secondary Test System	225
8.1.3	Measurement of the Resistive Burden	226
8.1.4	Checks During Commissioning	226
8.1.4.1	Test Windings, Test Sockets	227
8.1.4.2	Wiring Checks	228
8.1.4.3	Self-Supervision Contact for the WIC1-4	229
8.1.4.4	WIC1 Settings	229
8.1.5	Functional Test	229
8.1.5.1	Test Currents	230
8.1.5.2	Pickup Thresholds for the Phase Overcurrent Stage I>	231
8.1.5.3	Pickup Thresholds for the Short-Circuit (Phase Overcurrent) Stage I>>	232
8.1.6	Special Features for Tests of Calculated Ground (Earth) Overcurrent	233
8.1.6.1	Tripping Thresholds for the Calculated Ground Overcurrent Stage IG>	234
8.1.7	Sgen - Fault Simulator	236
8.2	Putting out of Operation – Plug out the Relay	238
8.3	Restart of the WIC1	238
8.4	Measuring the Trip Delay	239
9	Servicing and Maintenance	241
10	Technical Data	242
10.1	Technical Data – WIC1	242
10.1.1	Climatic and Environmental Data	242
10.1.2	Housing	242
10.1.3	Degree of Protection EN 60529	243
10.1.4	Phase Current Measurement	244
10.1.5	Ground Current Measurement	244
10.1.6	Power Supply	245
10.1.7	LEDs	245
10.1.8	Outputs	246

10.1.8.1	Impulse Output for the Tripping Coil	246
10.1.8.2	Impulse Output for a Flag Indicator	247
10.1.8.3	Relay Output (WIC1-4)	247
10.1.9	Remote (External) Trip Input / Digital Input (WIC1-1, WIC1-2, WIC1-3)	247
10.1.10	Digital Inputs (WIC1-4)	248
10.1.11	Terminal X6: RS485 (WIC1-4)	250
10.1.12	Terminal X7: Ethernet Interface (WIC1-4)	250
10.1.12.1	RJ45 connector (Terminal X7,WIC1-4)	251
10.1.12.2	Optical Ethernet with LC connector (Terminal X7,WIC1-4)	252
10.1.13	Smart view Connections	252
10.1.14	Self-Supervision Messages	252
10.2	Tolerances / Accuracy - WIC1	253
10.2.1	Protection Elements Accuracy	253
10.2.1.1	Phase Overcurrent Protection	253
10.2.1.2	Ground (Earth) Overcurrent Protection	255
10.2.1.3	Unbalanced Load [46], Negative-Sequence Current Protection [51Q]	257
10.2.1.4	Peak Overcurrent Protection	258
10.2.1.5	Inrush Blocking	258
10.2.1.6	Switch Onto Fault (SOTF)	259
10.2.1.7	Thermal Overload Protection	259
10.2.1.8	External Protection	260
10.2.2	Operating Times at Cold Start (CT supplied)	261
10.3	Technical Data - PC4 adapter	263
10.4	Technical Data - DiggiMEC	264
10.4.1	Climatic and Environmental Data	264
10.4.2	Housing	264
10.4.3	Degree of Protection EN 60529	265
10.4.4	Voltage Supply	265
10.4.5	Binary Output Relays	265
10.4.6	Standards - DiggiMEC	266
10.4.6.1	Approvals	266
10.4.6.2	Design Standards	266

10.4.6.3	Electrical Tests	267
10.4.6.4	Safety-Related Tests	269
10.4.6.5	Environmental Tests	270
10.5	Technical Data – WIC1 CTs	271
10.5.1	Technical Data – WIC1-Wx CTs, Construction Type 2	271
10.5.2	Technical Data – WIC1-Wx CTs, Construction Type 1	272
10.5.3	Maximum Cable Length for the WIC1-Wx CTs	272
10.5.4	Technical Data – WIC1-WC Converter CTs for 1 A, 5 A	273
10.5.5	Test Windings, Test Sockets	275
10.6	Technical Data – WI1SZ4	277
10.7	Technical Data – WI1SZ5	278
11	Troubleshooting	279
11.1	In Case You Need to Contact Our Service-Team	279
11.2	Self-Supervision Messages	280
11.2.1	Self-Supervision – Error Messages	281
11.2.2	Self-Supervision – Warning Messages	283
11.2.3	Self-Supervision – Information Messages	285
11.3	Signals via LEDs (at WIC1 or DiggiMEC)	287
11.4	Problems with the Device	289
11.4.1	Hardware	289
11.4.2	Operation of the Device	291
11.4.3	Parameter Settings	292
11.4.4	Protection and Control	293
11.4.5	Communication	294
12	Appendix	296
12.1	Appendix – Settings via DIP / HEX Switches	296
12.1.1	Settings via DIP / HEX Switches (WIC1-2, WIC1-3)	297
12.1.2	Setting of the Rated CT current In	305
12.2	Appendix – Time Overcurrent Characteristics	306
12.2.1	Characteristics (I>, I>>, I>>>)	306
12.2.1.1	DEFT – Definite Time-Overcurrent (I>, I>>, I>>>)	308
12.2.1.2	Inverse-Time Characteristics (I>, I>>, I>>>)	309

12.2.2	Characteristics (IG>, IG>>)	324
12.2.2.1	DEFT - Definite Time-Overcurrent (IG>, IG>>)	326
12.2.2.2	Inverse-Time Characteristics (IG>, IG>>)	327
12.2.3	Characteristics »I2>«	343
12.2.3.1	DEFT - Definite Time-Overcurrent (»I2>«)	345
12.2.3.2	Inverse-Time Characteristics (»I2>«)	346
12.3	Requirements for 1 A/5 A Standard CTs with WIC1-WC Converter CTs	361
12.4	Revision History	363
12.4.1	Version: 2.3	364
12.4.2	Version: 2.2	365
12.4.2.1	Hotfix Version: 2.2	366
12.4.3	Version: 2.1	367
12.4.3.1	Hotfix Version: 2.1	367
12.4.4	Version: 2.0	368
12.4.5	Version: 1.1	369
12.4.6	Version: 1.0	370
12.5	Standards - WIC1	371
12.5.1	Approvals	371
12.5.2	Design Standards	371
12.5.3	Electrical Tests	372
12.5.4	Safety-Related Tests	374
12.5.5	Environmental Tests	375
13	Index	377

1 Safety Messages and Proper Use of the WIC1

1.1 Important Definitions

The types of messages shown below serve the safety of life and limb as well as for the appropriate operating life of the device.

DANGER!



DANGER! indicates an immediately dangerous situation that will result in death or serious injury if it is not avoided.

WARNING!



WARNING! indicates a hazardous situation that can result in death or serious injury if it is not avoided.

CAUTION!



CAUTION! indicates a possibly hazardous situation that can result in minor or moderate injuries if it is not avoided.

NOTICE!



NOTICE! is used to address practices not related to personal injury.



This symbol indicates useful tips and recommendations as well as information for efficient and trouble-free operation.

1.2 Proper Use of the Device and of This Manual

CAUTION!



Do not put the WIC1 in service until it has been configured and commissioned.

Read the User Manual.

For configuring the required protection functions, read the related chapters within [↪5 Protective Elements](#).

In this context, it is also important to refer to the general [↪5.1 »Prot« - General Protection Module](#).

For commissioning, read [↪8 Commissioning](#) and the “Commissioning” sections within the chapters that are related to the required protection functions.

WARNING!



FOLLOW INSTRUCTIONS

Read this entire manual and all other publications pertaining to the work to be performed before installing, operating, or servicing this equipment. Practice all plant and safety instructions and precautions. Failure to follow instructions can cause personal injury and/or property damage.

WARNING!



PROPER USE

Any unauthorized modifications to or use of this equipment outside its specified mechanical, electrical, or other operating limits may cause personal injury and/or property damage, including damage to the equipment. Any such unauthorized modifications: (1) constitute “misuse” and/or “negligence” within the meaning of the product warranty thereby excluding warranty coverage for any resulting damage, and (2) invalidate product certifications or listings.

The programmable devices subject to this manual are designed for protection and also control of power installations and operational devices that are fed by voltage sources with a fixed frequency, i. e. fixed at 50 or 60 Hertz. They are not intended for use with Variable Frequency Drives. The devices are further designed for installation in low-voltage (LV) compartments of medium voltage (MV) switchgear panels or in decentralized protection panels. The programming and parameterization have to meet all requirements of the protection concept (of the equipment that is to be protected). You must ensure that the device will properly recognize and manage (e. g. switch off the circuit breaker) on the basis of your programming and parameterization all operational conditions (failures). The proper use requires a backup protection by an additional protective device. Before starting any operation and after any modification of the programming (parameterization) test make a documentary proof that your programming and parameterization meets the requirements of your protection concept.

Typical applications for this product family/device line are for instance:

- Feeder protection
- Mains protection
- Machine protection
- Transformer Protection
- Generator Protection

Any usage beyond these applications the devices are not designed for. This applies also to the use as a partly completed machinery. The manufacturer cannot be held liable for any resulting damage, the user alone bears the risk for this. As to the appropriate use of the device: The technical data and tolerances specified by *SEG* have to be met.

WARNING!



The bistable output relays of a DiggiMEC, that is connected to the WIC1, may be used only for visualization purposes. It is not permitted to use these relay contacts for any protection-related and/or switching purposes!

If the DiggiMEC relays are used for switching purposes there is the risk of an unreliable protection of your application!

Only the trip-coil output “TC+/-” of the WIC1 may be used for tripping a breaker.

(Further remarks can be found in →[“Remarks with respect to this warning”](#).)

WARNING!



Ensure that the actual overcurrent settings comply with the technical and thermal limits of the device, the CTs and the application!

Check the technical data (↪[10.1 Technical Data - WIC1](#)) for the permitted current input limits. When defining the protection settings, note that both current threshold and (delay) time must be set in consideration of the technical input limits.

- The thermal load capacity of the phase current inputs can be found here: ↪[10.1.4 Phase Current Measurement](#). The diagram and table in ↪[3.3 Current Transformers \(CTs\)](#) might also be useful.
- The thermal load capacity of the ground (earth) current inputs can be found here: ↪[10.1.5 Ground Current Measurement](#).

Unless there are any additional/external protective means installed we have to recommend that you activate at least one phase overcurrent protection stage considering the WIC1 limits ($2.5 \cdot I_{n,max}$ for 2.5 s, 25 kA for 1 s).

If your WIC1 features a ground (earth) current measuring input, these considerations should be applied in the same manner for one of the two ground overcurrent protection stages »IG>«, »IG>>«.

Ignoring the permitted limits will damage the WIC1, making it non-functional, and this can possibly result in serious damages of your equipment and even serious injury.

WARNING!



After connecting the terminals (see also the separate “Wiring Diagrams” document), make sure to fix the plastic cover again. (See ↪[3.1.1 Terminals, Screws and Torques](#) for the correct torque of the non-losable screw.)

The cover protects against inadvertently touching the contacts. Moreover, some WIC1 have an additional sticker with wiring information that should not get lost.

1.3 Personal Safety

DANGER!



Ignoring the following safety messages can result in death or serious injury or physical damage.

DANGER!



Only qualified electricians may install, commission, work or operate this device.

All national standards - if applicable - must be followed.

DANGER!



The terminal block for connection to the current transformers is not a shorting block. Therefore always short-circuit current transformers before loosening the terminals.

Ignoring this can result in dangerous voltages at the open contacts (up to dozens of kilovolts depending on the CT type).

DANGER!



Even when the auxiliary voltage is switched off, it is likely that there are still hazardous voltages at the component connections.

Upon opening the device, it is likely that some parts with high voltages become accessible. Touching these is dangerous to life.

The device must be carefully grounded. See [↔3.1.2 Grounding](#).

1.4 Important Information

NOTICE!



The devices are manufactured and delivered according to the **order code** specified by the customer.

CAUTION!



All electronic equipment is electrostatic-sensitive, some components more than others. To protect these components from electrostatic damage, you must take special precautions to minimize or eliminate electrostatic discharges. Follow these precautions when working with or near the control:

1. Before doing maintenance on the electronic control, discharge the static electricity on your body to ground by touching and holding a grounded metal object (pipes, cabinets, equipment, etc.).
2. Avoid the build-up of static electricity on your body by not wearing clothing made of synthetic materials. Wear cotton or cotton-blend materials as much as possible because these do not store static electric charges as much as synthetics.
3. Keep plastic, vinyl, and Styrofoam materials (such as plastic or Styrofoam cups, cup holders, cigarette packages, cellophane wrappers, vinyl books or folders, plastic bottles, and plastic ash trays) away from the control, the modules, and the work area as much as possible.

The WIC1 does not contain any parts that can be fixed or adjusted by the user. The housing is hermetically sealed and cannot be opened without causing damage.

Any unauthorized opening of the device will void the warranty.

Out-of-Date Documentation?



This publication may have been revised or updated since this copy was produced. To verify that you have the latest revision, please visit the download section of our website:

- <https://docs.SEGelectronics.de/wic1>

Please check this download area for the latest revision of this Technical Manual and whether there is an Errata Sheet with updated information. (The ID of every document is printed on its cover page.)

2 WIC1 – Introduction, Operation

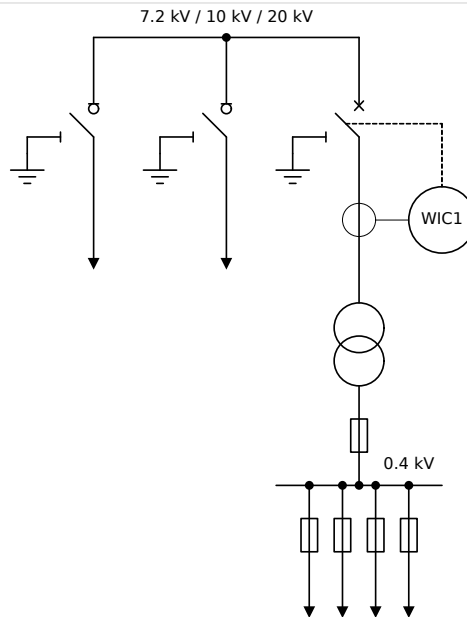

Fig. 2: Basic circuit diagram of a standard switchboard with 2 feeders and 1 outgoing transformer panel.

Introduction

The WIC1 is a CT-powered protection relay with inverse time and definite time protection characteristics and is specifically designed for switchboards with CBs and small rated output currents.

Together the specific CTs and the WIC1 form a joint protective system. A low-energy coil is needed for realizing trip of the CB.

The generation 2 of the WIC1 (also, short: WIC1 g2), that is described in this document, is the successor protection device of SEG's well-established WIC1 (for differentiation also: WIC1 g1), that is reliably in service within hundreds of thousands of MV switchboards.

The requirements on MS distribution stations with circuit breakers call for a robust protection relay which is optimized accordingly and an integral part of the respective switchboard. The WIC1 is a time-overcurrent relay that SEG has developed specifically for such requirements.

The WIC1 is a CT-powered protection relay with minimal space requirement, that complies with the highest demands on a digital protection device. Simple but safe wiring, high electromagnetic interference immunity, uncomplicated adjustment and the ability to scale to different power quantities of the switchboard, helping the switchgear manufacturer to minimize costs. The WIC1 represents a protective system with a guaranteed maintenance-free period of 25 years, the same as for the switchboard.

The SEG protection relays of the WI Line are offering time-overcurrent protective functions and earth fault protective functions in the well-proven technique for CT-powered protection relays.

As a CT-powered protection relay the WIC1 is mainly used in MV switchboards with circuit breakers, protecting distribution transformers in local and industrial networks. Due to its small size the WIC1 is very well suited for the use in compact switchboards.

The ability of the protection system WIC1 to adapt to different primary currents makes it possible that it is used for all standard rated transformer loads and the different medium voltage operational voltages.

The WIC1 is also available in device variants that can optionally be supplied with external power (so-called "Dual-Powered" WIC1). A stable external power supply allows for further functionality, e.g. SCADA communication. (See also [↔2.6.1 Order Forms.](#))



An overview of the elements and connectors can be found here: [↔3.1 Overview of Elements and Connectors](#)

2.1 Basic Wiring Concept

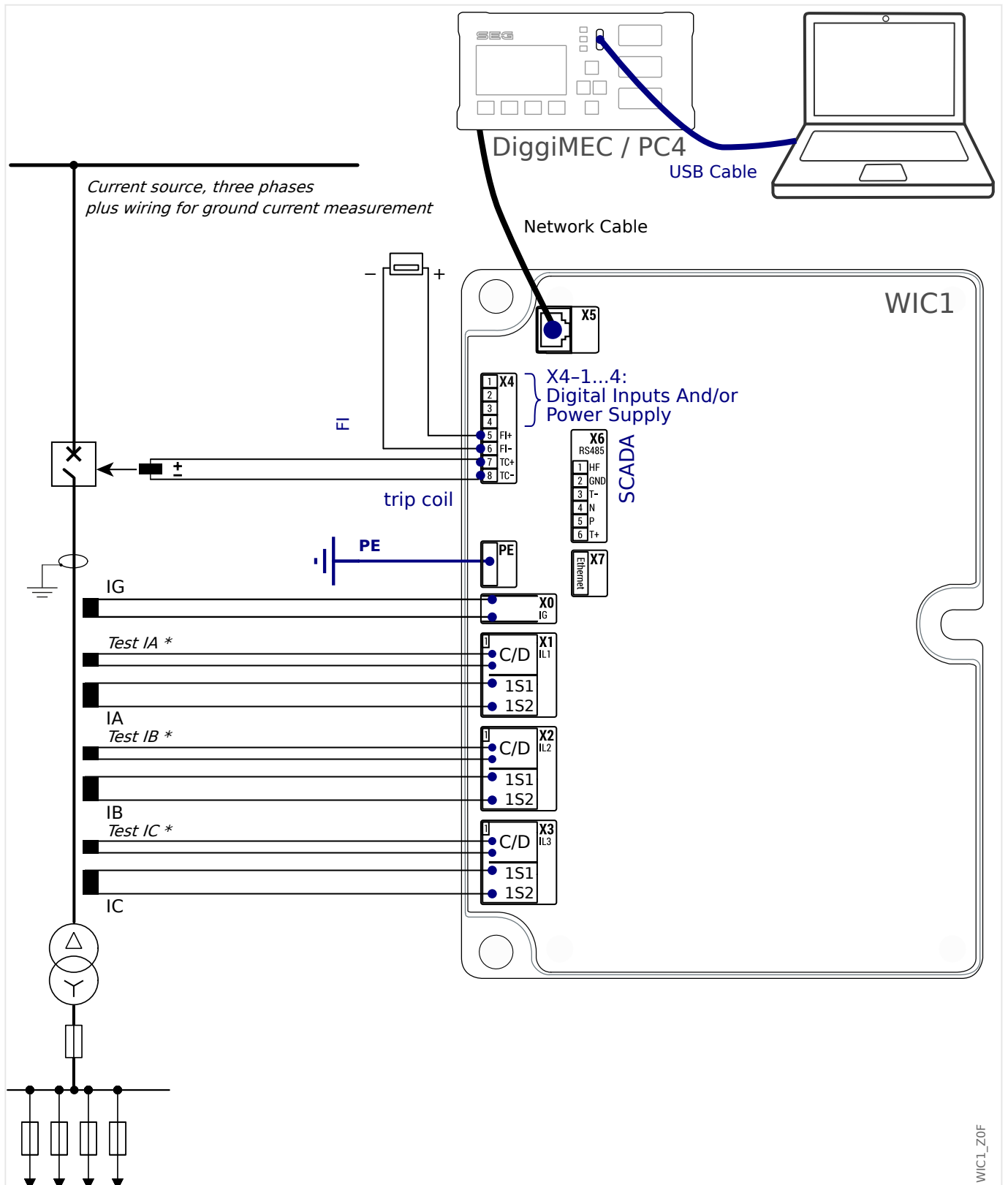

Fig. 3: Basic wiring concept.

(*) The test windings "C-D" are only necessary for the secondary tests during commissioning, see ↪8.1.4 Checks During Commissioning.

WIC1_Z0F

NOTICE!



The assignment of the contacts X4-1 ... X4-4 depends on the device variant. The separate document “WIC1 Wiring Diagrams” lists the exact contact assignments for each available typecode / order variant. It is recommended to look up this assignment for the WIC1 that is about to be wired.



If the use of 1 A (or 5 A) standard CTs is mandatory (for technical or historical reasons) it is possible to connect [special Converter CTs](#) between the 1 A CTs and the WIC1. See [↪3.3.2 WIC1-WC Converter CTs \(1 A / 5 A Measurement\)](#) for information.

2.2 Settings - Change Device Parameters

The WIC1 offers three possibilities to change the parameters of the device:

- PC via USB-connection (requires PC4 adapter or **DiggiMEC**[®] and the setting software *Smart view*)
- HMI via **DiggiMEC**[®]
- DIP/HEX Switches (only WIC1-2, WIC1-3)

Please note that the WIC1-1 and WIC1-4 can only be configured via PC/DiggiMEC. For the device variants WIC1-2 and WIC1-3 this is optional as there are DIP/HEX switches on the device. However, take care of the setting »Prot . *Settings valid*« in this case, see [Chapter 2.2.2](#).

2.2.1 PC via Smart view and DiggiMEC (HMI)

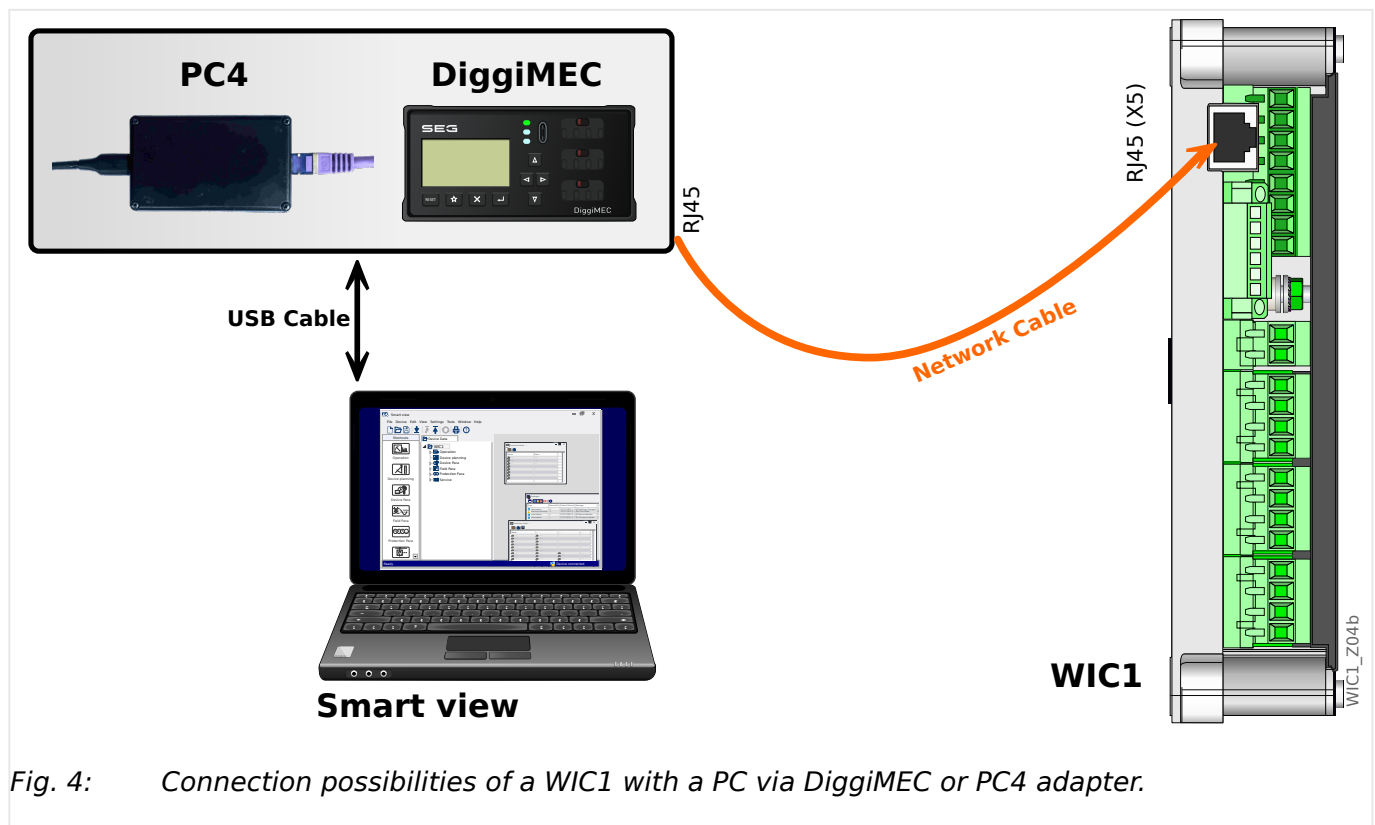

Fig. 4: Connection possibilities of a WIC1 with a PC via DiggiMEC or PC4 adapter.

The WIC1 can be connected to a Windows PC via both PC4 adapter or DiggiMEC using the setting software *Smart view*. Besides PC-connection the DiggiMEC also adds the possibility to fully configure the device via LCD display and keys. Depending on the [ordered type](#), it additionally adds flag indicators with output relays.

Contrast to the [DIP/HEX-based settings](#), the configuration via PC or DiggiMEC offers extended setting ranges and access to additional protection functions. Furthermore, measurement values and fault data can be retrieved from the device. (A separate document, WIC1-2.3-DE-REF.pdf, lists all parameters that can then be accessed. Note that this document is not relevant for DIP/HEX settings, because these cover only a small part of what is listed there.).

For more information about the PC4 adapter refer to [3.12 PC4 adapter - PC Interface for WIC1](#) and [10.3 Technical Data - PC4 adapter](#)

For more information about the DiggiMEC refer to ↪3.13 DiggiMEC® - Nano HMI with optional Flag Indicators and Output Relays and ↪10.4 Technical Data - DiggiMEC.

CAUTION!



Only PC4 adapter and DiggiMEC are permitted for connection with the RJ45 (X5) terminal of the WIC1 g2. Connecting a PC3 adapter or other equipment may damage the relay and lead to failure of protection!

2.2.1.1 Smart view

SEG offers a parameter and evaluation software for Windows PCs named *Smart view* (a separate manual is available online under <https://docs.segelectronics.de>). *Smart view* offers convenient functions for the following applications:

- Menu-controlled parameter setting incl. validity checks
- Offline configuration
- Reading and evaluating of measuring values
- Setting into operation assistance
- Display of the device status
- Fault analysis via fault recorder

For a complete WIC1 configuration it is recommended to use the *Smart view* setting and evaluation software, because it is too cumbersome to make a large amount of settings using the DiggiMEC panel.

Apart from plugging in the required cables, there are essentially two steps to be done for establishing a connection:

- In *Smart view*, click on [*Settings* → *Device Connection*], then select the type of connection to be used for the device. E.g. for a DiggiMEC select »WI Line (V2) DiggiMEC USB«.

After this, the connection has not been established yet, therefore you should not be confused if the status line still shows "Not connected".

- Click on [*Device* → *Receive Data from Device*] (or, alternatively, press »F2« on your keyboard, or click on the small icon with the blue arrow pointing down).

Smart view should now retrieve the complete menu tree, including all setting values and run-time data. After that, you should see a menu tree with the same top-level categories as on the DiggiMEC panel.

After the menu tree has been made available within *Smart view*, all further activities, such as changing a setting value, are straight-forward (and do probably not need a lot of detailed explanations): You can expand the (sub-)menu branches of any menu branch (click on the small angle next to the menu item, or a double-click on the item name), until you reach the required bottom-level item.

NOTICE!



If *Smart view* complains about a missing “device model” then your *Smart view* installation is probably older than the WIC1 firmware.

The “device model” is a file that defines the menu tree and all parameters, including factory defaults and setting ranges. It is needed by *Smart view* for showing the menu tree correctly and for making offline settings possible.

For the recent and all previous versions of the WIC1 firmware, the “device model” is part of the *Smart view* installation. So, if a WIC1-“device model” is missing, please install the latest *Smart view* version.

2.2.2 Validity of the DIP-/HEX-Switches

Many parameters and protection functions are not accessible by the DIP switches of the WIC1-2 or HEX switches of the WIC1-3. This is a natural result of the limited number of switches.

All these settings have appropriate default values, and inaccessible protection functions are deactivated. This way there is a well-defined functional range for the WIC1, so that it can be used only based on DIP/HEX settings, and vice versa, the DIP/HEX switches reflect the functionality in use sufficiently well.

Using the DiggiMEC / *Smart view*, however, the whole implemented functional range with all settings can be accessed. But if this “*software-settings*” operation mode is active, all DIP/HEX settings are ignored.

- This parameter defines for the WIC1-2 or WIC1-3 which settings shall be used:
- [Device planning / WIC1 + DiggiMEC] »Prot . *Settings valid*« =

Options:

- “Switches” — DIP/HEX settings shall be used.
- “Software” — DiggiMEC/*Smart view* settings shall be used.

NOTICE!



- In operating mode “Switches”, all the switches are permanently monitored, but with a particular delay of approx. 10 seconds. This means: Only after no further switching has been done after 10 s, all (DIP/HEX) switch positions are evaluated. If a new configuration results from the switch positions then the WIC1 performs a warm restart, so that it can properly resume operation based on the new settings.
- It is recommended to fix the acrylic glass cover after all DIP/HEX switch settings have been done. The cover offers some simple protection against unintended or unauthorized re-configuration.
- Due to technical (device-internal) constraints it is **not** possible to set the parameter »Prot . Settings valid« back from to “Software” to the “Switches” operation mode! If it is required to re-enable DIP/HEX switch settings the only way to do this is to set the WIC1 back to factory defaults. This will then make the WIC1 re-read all switch positions, and all other settings (that are inaccessible by the DIP/HEX switches) get set back to their respective default values; see also [↪2.12 Reset to Factory Defaults](#).
- Settings changes that are made via DIP/HEX switches are not automatically transferred to a connected Smart view. This means that Smart view still shows the previous setting until pressing the key »F2« at the PC (or Smart view menu item “Receive Data from Device”) makes Smart view retrieve all data again. Note that the “Auto Refresh” button / menu item is only for keeping the [Operation] menu branch of the device (i. e. measured values, states, etc.) updated. The “Auto Refresh” is not for settings.

A connected DiggiMEC, however, realizes and displays DIP/HEX switch changes as soon as they become effective.

NOTICE!



An offline configuration (i. e. prepare parameter settings in advance via *Smart view* and without a connected WIC1) is possible, even for a WIC1 variant with DIP/HEX switches. But it must be kept in mind that after selecting the typecode, *Smart view* always starts with the factory defaults for all settings. But this means that the initial setting for »Prot . Settings valid« is “Switches”, so that *Smart view* seems to have all (other) settings locked.

The first step for creating an offline configuration must therefore always be to set »Prot . Settings valid« = “Software”. Only after this will *Smart view* unlock all settings.

2.3 Supply of a WIC1

If a WIC1 is being operated in a typical application it is supplied via the CTs, and this is surely the normal case after commissioning.

But for the case of completeness, we want to list all ways to supply a WIC1:

Permanent Supply:

- Supply via the phase CTs, under the condition that these have been selected correctly (↪[3.3 Current Transformers \(CTs\)](#)) and there is sufficient phase current flowing (↪[10.1.6 Power Supply](#)).
- Only WIC1-4: Supply via an external auxiliary voltage (↪[10.1.6 Power Supply](#)). This is optional and independent of the supply via CTs. It enables the WIC1-4 to stay in operation after a protection trip, and only this allows for using some special functions, such as the Circuit Breaker Failure protection (↪[5.13 CBF – Circuit Breaker Failure \[50BF, 62BF\]](#)). Another example, that would be technically impossible without an additional external supply, is connecting an external output relay to be used as a self-supervision contact (↪[3.10.1 Self-Supervision Contact for the WIC1-4](#)).

Temporary Supply:

- Supply via the USB interface of a connected PC4 adapter or DiggiMEC (↪[2.2.1 PC via Smart view and DiggiMEC \(HMI\)](#)). This makes sense during commissioning and is independent of the supply via CTs (and of the external WIC1-4 supply).
 - Connecting a PC to the USB interface: This also enables the use of *Smart view*, see ↪[2.2.1 PC via Smart view and DiggiMEC \(HMI\)](#).
 - Connecting a powerbank to the USB interface: Whether this is possible or not depends on the type of powerbank. See “[Troubleshooting: Supply via Powerbank is not possible](#)”.

Note, however, that the USB supply is not designed as a permanent supply. Furthermore, a supply **only** via USB is not sufficient to enable a trip pulse (“[Troubleshooting: System-LED is Off](#)”), and therefore also the green System/Ready LED may stay off (↪“[The »System« LED\(s\) – “Ready”, “Error”](#)”).

Moreover, you should note that a DiggiMEC without a connected WIC1 is never operational, even with USB supply.

- For a short time (let us say: for a typical signal duration), the voltage of an external signal, that is applied at the Digital Input of the WIC1, can also boot up the WIC1, and this might under some circumstances be required for an external trip (↪[5.12 Exp – External Protection](#)).

WARNING!



Except for this special case of a short time signal (for an external trip), it is not permitted to feed any long-term or continuous voltage into the Digital Inputs.

In other words, it is strongly discouraged to try to supply the WIC1 (for a considerable time) via the Digital Inputs.

If this is ignored the Digital Input can be overloaded, and this can lead to a permanent damage of the WIC1.

2.4 WIC1 Protection Features

2.4.1 Functional Overview

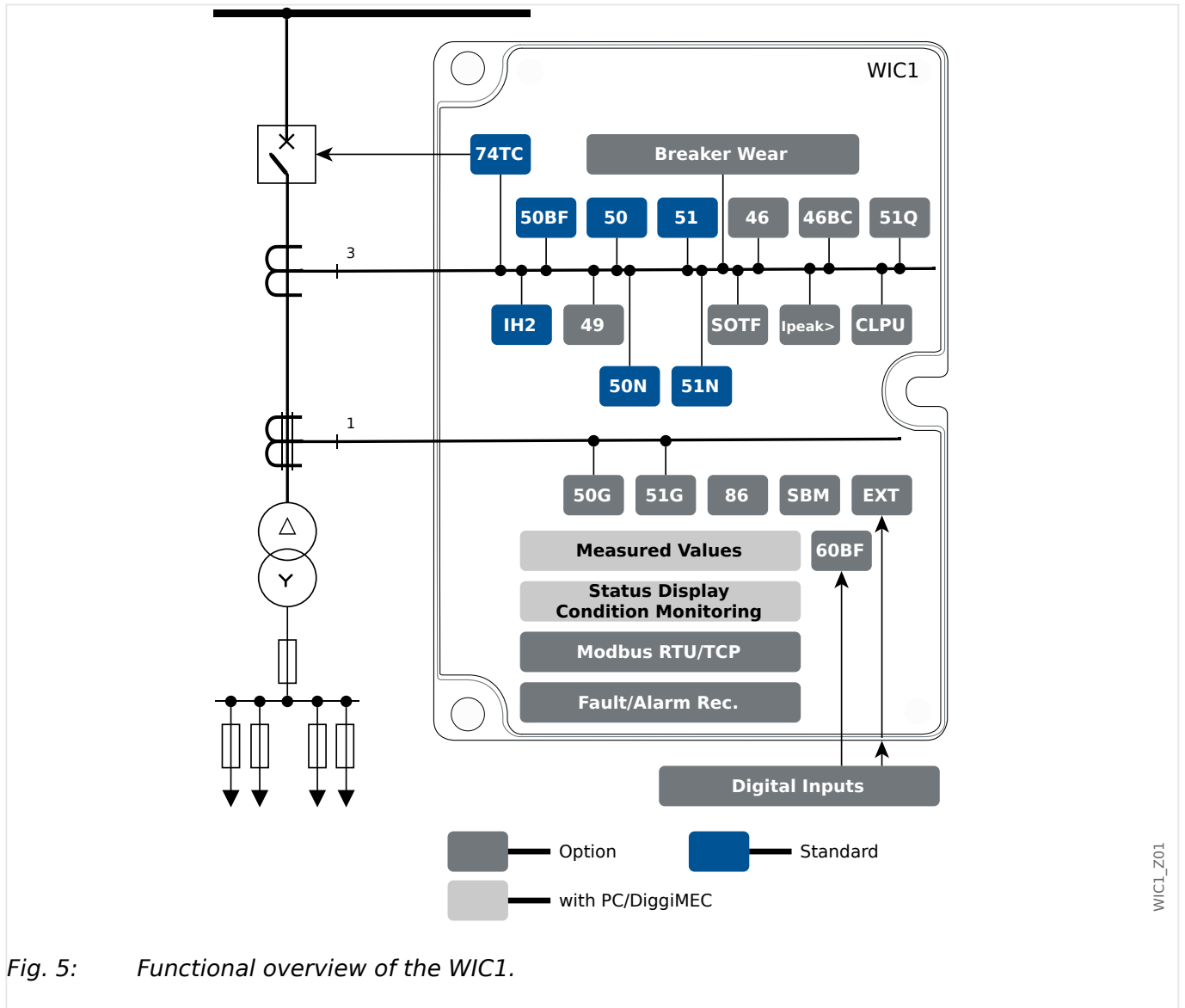

Fig. 5: Functional overview of the WIC1.

2.4.2 Device Features

Features	WIC1
Primary Application Type	
Self-/CT-Powered. (Device variant WIC1-4 with optional auxiliary power supply)	✓
Mounting Type	
Housing suitable for mounting plate	✓

Inputs and Outputs	WIC1
Inputs and Outputs of WIC1-1 ... WIC1-3	
Current transformer inputs	3 (phase currents), 1 ground current (option)
Binary inputs	0 ... 1 (option – only 115 VAC or 230 VAC)
Pulse Output	1 ... 2 (option)
Inputs and Outputs of WIC1-4	
Current transformer inputs	4
Binary inputs	0 ... 2 (option – supported input voltages: 24 Vdc / 48 Vdc ... 60 Vdc / 110 Vdc / 110 Vac / 230 Vdc / 230 Vac)
Pulse Output	1 ... 2 (option)

Protection and Supervision Features	ANSI / IEEE C37.2	WIC1
Protection		
Remark: Every protection function can also be configured to operate without tripping, i. e. as a supervision function.		
Time overcurrent protection	50 / 51	I>, I>>, I>>>
Inrush stabilisation (2nd harmonic)	IH2	IH2
Calculated ground (earth) fault protection	50N / 51N	IG>, IG>>
Measured ground (earth) fault protection	50G / 51G	IG>, IG>> <ul style="list-style-type: none"> • WIC1-1 ... WIC1-3: option • WIC1-4: ✓
Ultra-fast Peak Overcurrent protection		Ipeak> (option)
Unbalanced Load protection	46	I2/I1> (option)
Negative-Sequence Current Protection	51Q	I2> (option)
Thermal Overload protection	49	ThR (option)
Switch on to Fault (SOTF)		SOTF (option)
Cold Load Pickup (CLPU)		CLPU (WIC1-4)
External Trip		ExP (option)
Supervision		
Circuit breaker failure	50BF 62BF (WIC1-4 only)	CBF

Protection and Supervision Features	ANSI / IEEE C37.2	WIC1
Breaker Wear		Breaker Wear
Supervision of the Station Battery	(WIC1-4 only)	SBM
Condition Monitoring		
Peak Current Pointer		Peak Current Ptr
Life Load		Life Load
Recorders		
Fault recorder (non-volatile)	DFR	✓
Self-Supervision logging (messages about device-internal events – non-volatile)		✓
SCADA Communication		
(only WIC1-4)		
Modbus RTU	(only WIC1-4xxxxxxxBx)	✓
Modbus TCP	(only WIC1-4xxxxxxxCx, WIC1-4xxxxxxxLx)	✓

2.5 Comments on the Manual

This manual explains in general the tasks of device planning, parameter setting, installation, commissioning, operation and maintenance of the WI Line devices.

The manual serves as working basis for:

- Engineers in the protection field,
- commissioning engineers,
- people dealing with setting, testing and maintenance of protection and control devices,
- as well as trained personnel for electrical installations and power stations.

All functions concerning the type code will be defined. Should there be a description of any functions, parameters or inputs/outputs which do not apply to the device in use, please ignore that information.

All details and references are explained to the best of our knowledge and are based on our experience and observations.

This manual describes the (optionally) full featured versions of the devices.

All technical information and data included in this manual reflect their state at the time this document was issued. We reserve the right to carry out technical modifications in line with further development without changing this manual and without previous notice. Hence no claim can be brought based on the information and descriptions this manual includes.

Text, graphic and formulae do not always apply to the actual delivery scope. The drawings and graphics are not true to scale. We do not accept any liability for damage and operational failures caused by operating errors or disregarding the directions of this manual.

No part of this manual is allowed to be reproduced or passed on to others in any form, unless *SEG* have approved in writing.

This user manual is part of the delivery scope when purchasing the device. In case the device is passed on (sold) to a third party, the manual has to be handed over as well.

Any repair work carried out on the device requires skilled and competent personnel who need to be well aware especially of the local safety regulations and have the necessary experience for working on electronic protection devices and power installations (provided by evidence).

Information Concerning Liability and Warranty

SEG does not accept any liability for damage resulting from conversions or changes carried out on the device or planning (projecting) work, parameter setting or adjustment changes done by the customer.

The warranty expires after a device has been opened by others than *SEG* specialists.

Warranty and liability conditions stated in *SEG* General Terms and Conditions are not supplemented by the above-mentioned explanations.

2.5.1 Symbols in Function Diagrams

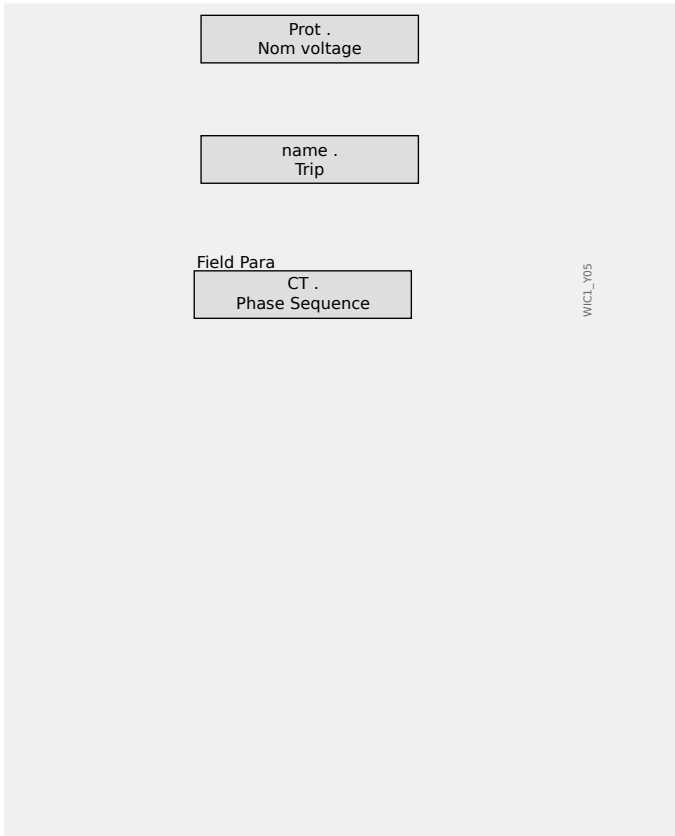

Setting Values

The upper box in the diagram on the left is the usual symbol of a setting value in a function diagram. The setting name is specified by its module and parameter name, separated by a dot “.” one from the other.

Second example: Thanks to the high degree of modularization in WI Line protection devices, the logic depicted in some function diagrams is often valid for several modules. In these cases, only a symbolic module name, for example: “*name*”, is given. In the heading part of the diagram, the meaning of “*name*” is specified as a list of modules to which the diagram applies.

In rare cases it is necessary to also specify the menu path (or at least the top-level menu item), because it would be too inconvenient to specify this particular setting only based on module name and parameter name. In the third example, the setting is marked as a Field Parameter (i. e. to be found within menu branch [Field Para]).

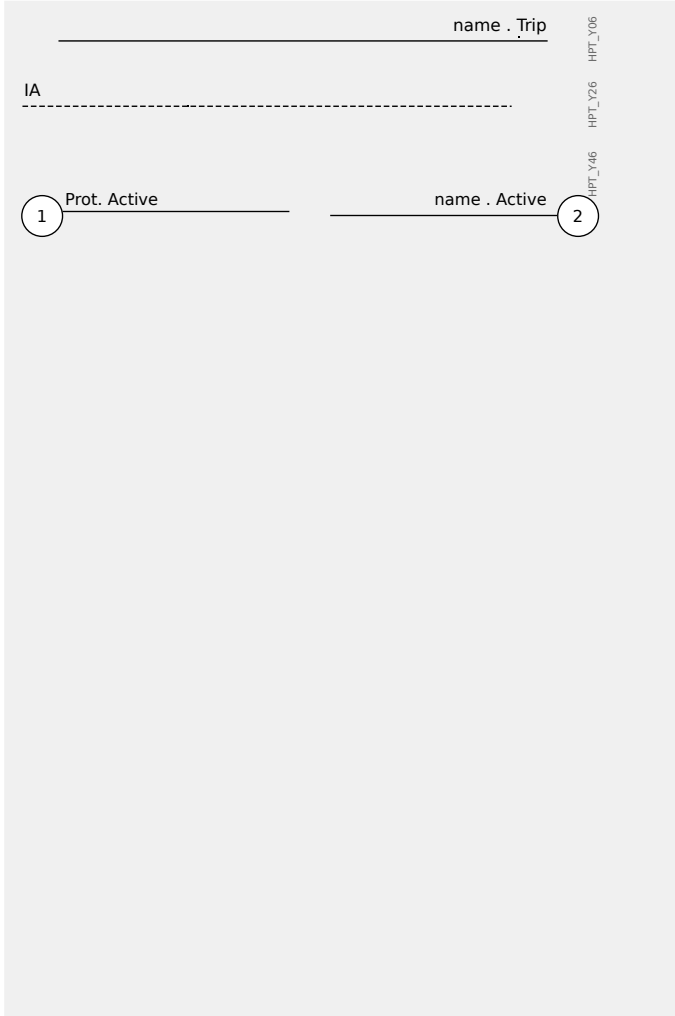

Input and Output Signals

A binary (output) signal is shown on top.

A dashed line indicates a measured value (i. e. an analog signal).

Bottom row left: Numbered input signal; right: numbered output signal: From the technical point of view, there is no difference to “normal” (non-numbered) signals.

Some of these numbers, however, represent generic signals. For example, every protection function has a trip signal »*Trip*«, and there is always the same number used for it, independent of the particular protection function.

A numbered signal typically appears in several different diagrams, and the numbering helps to identify and locate them across the Technical Manual.

Therefore all encircled numbers appearing “on the right side” (i. e. as an output signal) of a diagram are listed as part of the Index chapter (sorted below the initial letter “⊗”), so that you can look up where a particular signal has been “generated”.

Wherever technically possible, these input numbers within a diagram are hyperlinks, and a click takes you to a page where this numbered signal is explained or shown as an output signal.

Another remark: All diagrams in this document show a small label, for example the bottom one: "HPT_Y46". This is the diagram name, i. e. a unique identifier for the diagram. Of course, this is not a setting name, nor any other part of the depicted logic. All function diagrams have an identifier with the characters "_Y".)

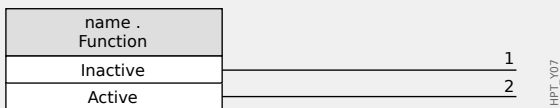

If the setting value of parameter »name . Function« is set to "Inactive", then output 1 is active and output 2 is inactive.

If the setting value of parameter »name . Function« is set to "Active", then output 1 is inactive and output 2 is active.

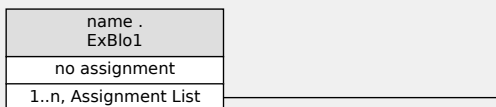

The setting value of parameter »name . ExBlo1« is not a choice from a simple, fixed selection list, but it is another parameter (usually a binary output signal) that is assigned from a parameter list.

This means that the setting parameter assumes the value of the assigned parameter. In case of a binary output signal, for example, it means that the parameter »name . ExBlo1« is active whenever the assigned output signal is active.

If no signal has been assigned then the output is always inactive (and only the "no assignment" box, which is not connected in this example, would be active).

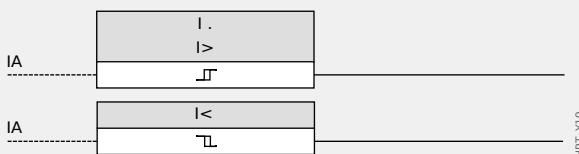

Two types of comparators ("Schmitt triggers"):

Top row: If the analog input value (here: the phase current IA) is greater than the specified threshold (here: the setting value of the parameter »I . I>«) then the output becomes active.

Bottom row: This type has the opposite functionality: If the analog value IA is **below** the threshold (here: the setting value of the parameter I<«) then the output becomes active.

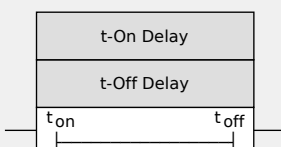

Timer stage: If the input becomes active, then the output becomes active after the time t_{on} (setting value of »t-On Delay«) has elapsed (switch-on delay).

2 WIC1 - Introduction, Operation

2.5.1 Symbols in Function Diagrams

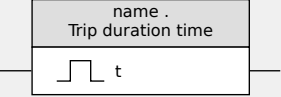
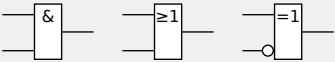
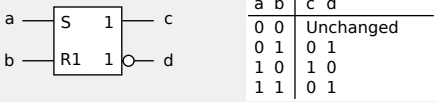
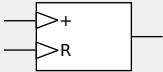
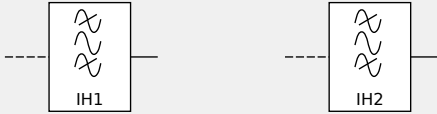
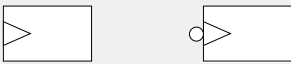
	<p>If the input becomes inactive again, then the output signal becomes inactive after the other specified duration has elapsed (switch-off delay t_{off}, setting value of »t-Off Delay«).</p>																				
	<p>Hold time: This is a pulse which is triggered by the input (and in this case, the pulse duration is settable via parameter).</p>																				
	<p>The usual set of logic operators: AND, OR, eXclusive OR (from left to right). The second input of the XOR operator is negated.</p>																				
 <table border="1" data-bbox="435 680 627 790"> <thead> <tr> <th>a</th> <th>b</th> <th>c</th> <th>d</th> </tr> </thead> <tbody> <tr> <td>0</td> <td>0</td> <td colspan="2">Unchanged</td> </tr> <tr> <td>0</td> <td>1</td> <td>0</td> <td>1</td> </tr> <tr> <td>1</td> <td>0</td> <td>1</td> <td>0</td> </tr> <tr> <td>1</td> <td>1</td> <td>0</td> <td>1</td> </tr> </tbody> </table>	a	b	c	d	0	0	Unchanged		0	1	0	1	1	0	1	0	1	1	0	1	<p>RS flip-flop with reset priority.</p>
a	b	c	d																		
0	0	Unchanged																			
0	1	0	1																		
1	0	1	0																		
1	1	0	1																		
	<p>Edge-triggered counter.</p>																				
	<p>Band-pass filter (left: IH1, right: IH2).</p>																				
	<p>Edge-triggered block: Output is active in case of a positive (negative) edge at input.</p>																				

2.6 Information About the Device

Scope of Delivery

The delivery scope includes:

- **(1)** — The transportation box
- **(2)** — The protective device
- **(3)** — The test report

Please check the consignment for completeness on arrival (delivery note).

Please ascertain whether the type plate, connection diagram, type code and description of the device are matching your order.

If you have any doubts please contact our Service Department (contact address to be found on the reverse of the manual).

Download Area

All technical documentation (User Manual, Reference Manual, etc.) and setup files for the Windows applications (Smart view, DataVisualizer) can be downloaded directly (and without any costs) from <https://docs.SEGelectronics.de/wic1>.

- <https://docs.SEGelectronics.de/wic1> — This web address is also available as a QR code directly on the housing of the device.
- https://docs.segelectronics.de/smart_view — Setup of the Windows applications incl. documentation.

Product DVD

A product DVD with all technical documentation (User Manual, Reference Manual, etc.) and setup files for the Windows applications (Smart view, DataVisualizer) can be ordered separately. This way users who are not connected to the internet can get all files that are required or useful during commissioning.

Storage, Transport and Installation

The devices must not be kept outside, but only in dry, well-ventilated locations. See also [↪10.1.1 Climatic and Environmental Data](#).

During transport and for installation, the classifications under [↪12.5.5 Environmental Tests](#) regarding vibration and shock also apply.

In addition for installation, the protection classifications specified under [↪10.1.3 Degree of Protection EN 60529](#) must be applied.

Waste Disposal

In general, appropriate local guidelines and regulations must be followed when disposing of electrical devices.

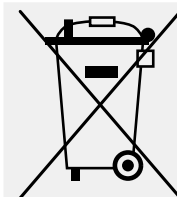

2.6.1 Order Forms

There are four different main variants of the WIC1 available, and these can have different additional order options:

- WIC1-**1**...: CT-Powered Protection Device without any switches, all settings are made via Smart view (PC) / DiggiMEC. See [↔2.6.1.1 Order Form of the CT-Powered Device Types](#).
- WIC1-**2**...: CT-Powered Protection Device with DIP switches, all settings can be made either with these DIP switches, or – more exactly – via Smart view (PC) / DiggiMEC. See [↔2.6.1.1 Order Form of the CT-Powered Device Types](#).
- WIC1-**3**...: CT-Powered Protection Device with HEX switches, all settings can be made either with these HEX switches, or – more exactly – via Smart view (PC) / DiggiMEC. See [↔2.6.1.1 Order Form of the CT-Powered Device Types](#).
- WIC1-**4**...: Dual-Powered Protection Device without any switches, all settings are made via Smart view (PC) / DiggiMEC. Various additional features, such as SCADA communication, are optionally available. See [↔2.6.1.2 Order Form of the Dual-Powered WIC1-4](#).

Please note the configuration via Smart view (PC) needs an additional interface-device (PC4 or DiggiMEC) for the USB-connection to the PC.

For the order form of the PC4, see [↔2.6.1.6 Order Form of the PC4 adapter](#).

For the order form of the DiggiMEC, see [↔2.6.1.7 Order Form of the DiggiMEC](#).

For the order forms of the WIC1-compatible CTs, see [↔2.6.1.3 Order Form of the WIC1-Compatible Current Transformers](#).

For the order forms of the WIC1-compatible Flag Indicators [WI1SZ4](#) and [WI1SZ5](#), see [↔2.6.1.4 Order Form WI1SZ4](#) and [↔2.6.1.5 Order Form WI1SZ5](#), respectively.

PC4 adapter / Smart view (PC)

The PC4 adapter is an interface device to connect the WIC1 with a PC or laptop. The PC can then execute the parameterizing and analyzing software Smart view and enables the user to make all settings via this connection, or to save settings to a file on the PC, or retrieve measured values or trip event data.

See [↔2.6.1.6 Order Form of the PC4 adapter](#).

DiggiMEC / Smart view (PC)

The DiggiMEC is a small device that has to be ordered separately. It fits into a standard door cutout of 92 mm × 45 mm (DIN IEC 61554) and can be connected to the WIC1 (via a standard network cable with RJ45 plugs). It then adds an HMI, i. e. a graphical display and hardware keys, to the WIC1. Moreover, it offers 0/1/3 bi-stable output relays that are mechanically combined with flag indicators.

See [↔2.6.1.7 Order Form of the DiggiMEC](#).

- DiggiMEC-0: 0 bi-stable relays / flag indicator
- DiggiMEC-A: 1 bi-stable relay / flag indicator
- DiggiMEC-B: 3 bi-stable relays / flag indicators

If the DigiMEC user interface is connected to the WIC1, it is also possible to connect a PC to the USB interface of the DigiMEC.

The PC can then execute the parameterizing and analyzing software Smart view and enables the user to make all settings via this connection, or to save settings to a file on the PC, or retrieve measured values or trip event data.

2.6.1.1 Order Form of the CT-Powered Device Types

CT Powered Time Overcurrent and Earth Current Relay										
WIC1	-	#	#	#	#	#	#	#	#	#
Mounting form		↓								
Parameter setting via Smart view (PC) or DiggiMEC		1								
Parameter setting via DIP switches, Smart view (PC) or DiggiMEC		2								
Parameter setting via HEX switches, Smart view (PC) or DiggiMEC		3								
CT Type, DIP/HEX Range			↓							
Wx CTs or WC1 Converter CTs, DIP/HEX Range 1			S							
WC2 Converter CTs, DIP/HEX Range 2			D							
Ground Current Method				↓						
Calculated Ground Current *6)				N						
Configurable (Meas. Ground Current default) *1)				G						
Configurable (Calc. Ground Current default) *1)				B						
Nominal frequency					↓					
50 Hz *2) (only WIC1-2, WIC1-3)					5					
60 Hz *2) (only WIC1-2, WIC1-3)					6					
50 Hz / 60 Hz *2) (WIC1-1 only)					0					
Outputs						↓				
"TC" (Trip Coil pulse) output: Trip Command "FI" (Flag Indicator pulse) output: without or Self-Supervision *3)						N				
"TC" (Trip Coil pulse) output: Trip Command "FI" (Flag Indicator pulse) output: Trip Command *6)						F				
"TC" (Trip Coil pulse) output: Trip Command "FI" (Flag Indicator pulse) output: configurable						C				
Inputs							↓			
No digital inputs *6)							N			
External trip input (115 Vac or 230 Vac) *6)							F			
1 assignable Digital Input (115 Vac or 230 Vac)							C			
Backup Protection / Self-Supervision								↓		
Self-Supervision operates "FI"-Output *3) *4)								0		
Self-Supervision operates "TC"-Output *4)								1		
Self-Supervision operates "TC"-Output (if I > 20 * In,max)								2		
Protection Packages									↓	
ANSI 50, 50G/N, 51, 51G/N, Inrush Blocking, 50BF, 74TC									S	
Package "S" + ANSI 46, 49, 51Q, Breaker Wear, Condition Monitoring (= Life Load, Drag Indicator)									A	
Package "A" + SOTF, external protection *5), ultra-fast overcurrent protection									P	
Communication										↓
Without communication protocol										A
Customized Version										↓

CT Powered Time Overcurrent and Earth Current Relay											
WIC1	-	#	#	#	#	#	#	#	#	#	#
Standard											0
Version 1											H

NOTICE!



*1) Via Smart view (PC) / DigiMEC (but not via DIP/HEX switches), it is possible to configure the device for either calculated or measured ground (earth) current. The input for the measured ground (earth) current has a rated current of 1 A.

*2) Via Smart view (PC) / DigiMEC (but not via DIP/HEX switches), it is possible to configure the device for either 50 Hz or 60 Hz nominal frequency.

*3) Self-Supervision via "FI" is only available in the combination:

- »Outputs« = "N" **and**
- »Backup Protection / Self-Supervision« = "0"

Please note that the Flag Indicator "FI" output cannot be used for other signals (e.g. a Trip) anymore in this case (except [↪5.14.2 »TCM« - Trip Circuit Monitoring \[74TC\]](#)).

*4) Trip of the backup protection as soon as sufficient electrical energy for a trip impulse has been collected. This requires the device to be powered sufficiently (see [↪2.3 Supply of a WIC1](#)).

*5) External protection is usable only with a Digital Input.

*6) This variant is not available for sale anymore. It is still supported by the latest firmware for older devices.

2.6.1.2 Order Form of the Dual-Powered WIC1-4

Dual-Powered Time Overcurrent and Earth Current Relay											
WIC1	-	#	#	#	#	#	#	#	#	#	#
Mounting form		↓									
Dual-Powered Powered Relay, parameter setting via Smart view (PC) or DigiMEC		4									
CT Type, DIP/HEX Range			↓								
Wx CTs or WC1 Converter CTs, DIP/HEX Range 1			S								
WC2 Converter CTs, DIP/HEX Range 2			D								
Ground Current Method				↓							
Configurable (Meas. Ground Current default) *1)				G							
Configurable (Calc. Ground Current default) *1) *6)				B							
Nominal frequency					↓						
50 Hz / 60 Hz *2)					0						
Outputs						↓					
"TC" (Trip Coil pulse) output: Trip Command "FI" (Flag Indicator pulse) output: without or Self-Supervision*3)							N				
"TC" (Trip Coil pulse) output: Trip Command "Out" (Flag Indicator) output: Trip Command *6)							F				
"TC" (Trip Coil pulse) output: Trip Command "Out" output: configurable							C				
Inputs								↓			
No digital inputs *6)								M			
External trip input, external reset input *5) *6)								G			
2 assignable Digital Inputs *5)								D			
Backup Protection / Self-Supervision									↓		
Self-Supervision operates "FI"-Output *3) *4)									0		
Self-Supervision operates "TC"-Output *4)									1		
Self-Supervision operates "TC"-Output (if I > 20 * In,max)									2		
Protection Packages										↓	
ANSI 50, 50G/N, 51, 51G/N, Inrush Blocking, 50BF, 74TC											S
Package "S" + ANSI 46, 49, 51Q, Breaker Wear, Condition Monitoring (= Life Load, Drag Indicator)											A
Package "A" + SOTF, CLPU, external protection*5), ultra-fast overcurrent protection											P
Communication											↓
Without communication protocol											A
Modbus RTU RS485 / terminals											B
Modbus TCP Ethernet 100 MB / RJ45											C
Modbus TCP Optical Ethernet 100 MB / LC duplex connector											L
Customized Version											↓
Standard											0

Dual-Powered Time Overcurrent and Earth Current Relay												
WIC1	-	#	#	#	#	#	#	#	#	#	#	#
Version 1												H

NOTICE!



- *1) Via Smart view (PC) / DiggiMEC (but not via DIP/HEX switches), it is possible to configure the device for either calculated or measured ground (earth) current. The input for the measured ground (earth) current has a rated current of 1 A.
- *2) Via Smart view (PC) / DiggiMEC (but not via DIP/HEX switches), it is possible to configure the device for either 50 Hz or 60 Hz nominal frequency.
- *3) Self-Supervision via "FI" is only available in the combination:
 - »Outputs« = "N" **and**
 - »Backup Protection / Self-Supervision« = "0"

Please note that the Flag Indicator "FI" output cannot be used for other signals (e.g. a Trip) anymore in this case (except [↪5.14.2 »TCM« - Trip Circuit Monitoring \[74TC\]](#)).
- *4) Trip of the backup protection as soon as sufficient electrical energy for a trip impulse has been collected. This requires the device to be powered sufficiently (see [↪2.3 Supply of a WIC1](#)).
- *5) Supported input voltages for Digital Inputs: 24 Vdc / 48 Vdc ... 60 Vdc / 110 Vdc / 110 Vac / 230 Vdc / 230 Vac. External protection is usable only with at least one Digital Input.
- *6) This variant is not available for sale anymore. It is still supported by the latest firmware for older devices.

2.6.1.3 Order Form of the WIC1-Compatible Current Transformers

WIC1-Wx CTs

Officially tested and recommended CTs for the WIC1 exist in two independent (electrically equivalent and interchangeable) construction types.

Current Transformer (1 Piece)			
Short name + Primary Current Range	Accuracy Class	Order Code Construction Type 2	Order Code Construction Type 1
WE2 [16 - 56 A]	5P80	WIC1- CT2 -5P	WIC1- WE2AS1
W2 [16 - 56 A]	10P80	WIC1- CT2 -10P	WIC1- W2AS1
W3 [32 - 112 A]	5P80	WIC1- CT3	WIC1- W3AS1
W4 [64 - 224 A]	5P80	WIC1- CT4	WIC1- W4AS1
W5 [128 - 448 A]	5P80	WIC1- CT5	WIC1- W5AS1
W6 [256 - 896 A]	5P80	-	WIC1- W6AS1

For further technical data of these CTs see [↔3.3.1.1 Current Ranges of the WIC1-Wx-CTs](#).

WIC1-WC Converter CTs for 1 A or 5 A

If the use of 1 A (or 5 A) standard CTs is mandatory (for technical or historical reasons) it is possible to connect special Converter CTs between the standard CTs and the WIC1. See [↔3.3.2 WIC1-WC Converter CTs \(1 A / 5 A Measurement\)](#) for information, [↔“WIC1-WC Converter CTs for 1A / 5A”](#) for dimension drawings and [↔10.5.4 Technical Data - WIC1-WC Converter CTs for 1 A, 5 A](#) for Technical data.

WIC1-WC Converter CT (for 3 phases, combined in 1 housing)	
Short name + Rated Current	Order Code
Converter CT 1 A, Type 1	WIC1-WC1-1A
Converter CT 5 A, Type 1	WIC1-WC1-5A
Converter CT 1 A, Type 2	WIC1-WC2-1A

Both **WC1** and **WC2** CTs are limited to special order codes of the WIC1. Please make sure you have the correct combination of relay type and WC CT. Please refer to [↔2.6.1 Order Forms](#) for more information.

2.6.1.4 Order Form WI1SZ4

Flag Indicator	Article Number
Small type, front 34 × 23 mm	WI1SZ4

2.6.1.5 Order Form WI1SZ5

Flag Indicator	Article Number
Small type, front 34 × 23 mm, with bi-stable signal contacts (230 V AC / 3 A, 24 V DC / 2 A)	WI1SZ5

2.6.1.6 Order Form of the PC4 adapter

USB connection interface for WIC1 and PC	Article Number
PC4 adapter	WIC1PC4

2.6.1.7 Order Form of the DiggiMEC

Nano-HMI with optional Flag Indicators			
DiggiMEC	-	#	#
Type		↓	
Door mounting, 0 bi-stable relays / flag indicators		0	
Door mounting, 1 bi-stable relay / flag indicator		A	
Door mounting, 3 bi-stable relays / flag indicators		B	
Customized Version			↓
Standard			0 *)
Version 1			H

NOTICE!



*) If not further specified on the DiggiMEC, the **Standard** version "0" is used. (This only applies for older models.)

2.7 Device Planning

“Device Planning” means to change the functional range to a degree that suits the protection task to be fulfilled. There is a top-level menu item [Device planning] that is dedicated to this, and it makes essentially the following types of settings available:

- For WIC1-2 und WIC1-3: Define whether the device is configured via DIP/HEX-switches (factory default) or via Software (Smart view (PC) oder DiggiMEC).
- Activation of the functions that are needed for the application, and deactivation of the other ones.
- For the activated protection functions: Select whether these shall trip the circuit breaker or issue a warning message. See ↪[“Definition \(“Alarm ↔ Trip”\) of a Protection Function”](#) for information on this.

Switch Settings or Software Settings

Device variants WIC1-2 and WIC1-3 are set via DIP or HEX switches, respectively. But independent of these switch settings it is still possible to make settings via Smart view (PC) / DiggiMEC.

To prevent a potential conflict between what is set via the switches, and what is set via Smart view (PC) / DiggiMEC, there is the setting [Device planning] »*Settings valid*«. It selects whether the WIC1 shall actually use the switch settings or the Smart view (PC) / DiggiMEC settings.

The factory default of »*Settings valid*« is “Switches”, so that it is possible to configure these devices without a PC4 adapter or DiggiMEC.

Note that not all settings of the WIC1-2 / WIC1-3 can be “reached” via DIP / HEX switches. This has the effect that for a configuration via switches (»*Settings valid*« = “Switches”), all settings that are not assigned to any DIP / HEX switch are always set to their respective factory defaults. See also ↪[Chapter 2.2.2](#).

Activation of Functions

In general, it is always important to activate only those functions that are needed, and deactivate the others. (Of course, this is particularly essential when settings are made via Smart view (PC) / DiggiMEC. For devices with DIP or HEX switches, there is already a factory default for this.)

The menu [Device planning] collects a setting parameter named »*Mode*« for each function, which can be set to “-” or to “use”.

If the user, for example, deactivates the inrush protection function, all menu branches related to this function disappear from the menu tree. All corresponding events, signals, etc., are deactivated as well. This simplifies the menu tree.

WARNING!



It **MUST** be taken into account that Device Planning changes the functionality of the device.

If the user deactivates a protection function, the device will no longer trip according to the criteria related to this protection function.

The manufacturer does not accept liability for any personal or material damage as a result of incorrect planning.

Contact your SEG Customer Service representative for more information. SEG also offers configuration support as a service.

WARNING!



Beware of the inadvertent deactivating of protective functions/modules, because all the settings of a deactivated module get lost (i. e. are set back to their respective default values)!

This means: If the user is activating any of these modules again at some later time, all parameters of the re-activated modules need to be reconfigured.

2.8 Modules, Settings, Signals and Values

The WIC1 is a digital protection device that holds various data in its internal memory. Some data is meant to be changed by the user to adapt the functionality to the respective application, other data types are set by the device during run-time and are therefore read-only from the user's perspective.

All settings, device planning and checking the state of signals at run-time can be done:

- Directly at a DiggiMEC that is connected to the WIC1; or
- using the *Smart view* software application.

Modules

The firmware of the WIC1 can be thought of being sub-divided in several independent function blocks. Throughout our Technical Documentation, we are talking of “modules” (or sometimes of “functions”). Every protection function, for example, is a module of its own. For WI Line devices, this is a fundamental concept. For example, there is a general protection module (named »Prot«, see ↪5.1 »Prot« – General Protection Module) that interacts with all specific protection modules.



It is important to know that every parameter and every signal and value is always part of exactly one module (even if the module name might not be displayed on the DiggiMEC display for the sake of simplicity).

Modules can interact with each other, either because this is a fixed implemented part of the firmware, or if the user has assigned some signal of a module to a parameter (that becomes a module input this way). An example for a fixed implemented interaction is that the trip signal of any protection module always triggers the trip signal of the general »Prot« module.

Some modules exist in several (identical) instances, which can be activated and configured independently. These can be used to have several protection stages. However, there is one fundamental difference to the WIC1: The functionality of all instances (of a particular module) is always identical (except for the differences that are due to different setting values).

There is the following naming convention: If several instances of a module »Module« exist, then these are named »Module[1]«, »Module[2]«, ... (or, as a short form for descriptions: »Module[x]«).

Types of Settings, Signals and Values

Settings (also called parameters)

- Parameters are data that can be modified by the user, to adapt the functionality of the respective application.

Smart view users can save all settings to a file. This is a file with a filename of the form *.WiPara. It can be (re-)loaded at any later time, and the setting values contained therein can be transferred to some (other) WIC1 protection device. (For details see the *Smart view* manual.)

(Remark: There are a few exceptions, where a particular setting is always stored within the device and never saved to a *.WiPara file. This is the case if it is not desirable to directly transfer the setting value from one device to another.)

There are several types of parameters, depending on the type of data they can hold. For the user, it is not necessary to know details, but it can be good to know

that there are numerical parameters (e. g. overcurrent thresholds) and parameters which hold one option out of a selection list. These select options can either be fixed values, or they can be a signal (so that during run-time, the actual parameter value equals the state of the assigned signal).

- Some parameter properties depend on the value of particular other parameters. For example, the “device planning” parameters (in the [Device planning] menu, see [↪2.7 Device Planning](#)) do not only activate or deactivate protection functions but also control the visibility of their related parameters.

Some parameters depend on others not only with respect to visibility, but also default values and/or available value ranges.

Direct Commands

- **Direct Commands** are part of the “menu tree”, just like a setting parameter, but they are meant to be executed immediately. Therefore Direct Commands are **NOT** part of a *.WiPara parameter file.

Signals

- *Signals* are run-time states, i. e. depend on the result of a protection function or on the state of a Digital Input.

Signals are part of the “menu tree”. They can all be found in the menu path [Operation / Status Display].

- Some *Signals* are assessments of the state of the grid and the equipment.
- Some *Signals* represent decisions that are taken by the device (e. g. a trip) based on the parameter settings.
- Many signals can be *assigned* to particular parameters. This means the function of this parameter depends on the run-time state of the signal. For example, a signal can be assigned to the 2nd or 3rd DiggiMEC LED, so that the LED is lit as soon as the assigned signal becomes “True”. (See also [↪3.11.2 LED Configuration \(DiggiMEC\)](#).)

Input States (for a module input)

- Input States are special signals and are part of the “menu tree”. For every parameter to which a signal can be assigned, there is a related Input State. At run-time, the Input State reflects the current state of the assigned signal. This way the dependencies in the behavior of a protection function can be traced.

There is the following naming convention: If a parameter to which a signal can be assigned is named »Name«, then the related Input State has the name »Name-I«.

Counters, Values

- *Values* are more or less volatile data that are constantly kept up to date during run-time.
- The most common (and most important) type of Values is the set of *Measured Values* (e. g. the current values); we are going to use the term *Measured Values* also for values that are derived from measured values by calculation, e. g. the ground (earth) current value can be calculated from the phase currents). Of course, the set of available *Measured Values* depends on the capabilities of the particular WIC1 variant.

2.9 Measuring Values

Read out Measured Values

In menu [Operation / Measured Values], both measured and calculated values can be viewed. The set of available measured values depends on the WIC1 variant.

Display Options

The user can define how measured values are to be displayed in Smart view (PC) or DigiMEC (HMI):

- Current values are displayed relative to the nominal current I_n , or:
- Current values are displayed as primary values in A.

Of course, primary values can be displayed only if the connected CT type has been correctly configured. Besides, there are further, variant-specific aspects, because the related parameters cannot be reached via DIP/HEX switches.

Settings via Software

WIC1-1, WIC1-4, or WIC1-2, WIC1-3 with the setting »Prot . Settings valid« = “Software”:

The display options, CT type and nominal current (»In,relative« or »CT pri«) are set via ordinary [setting parameters](#) within the menu branch [Field Para / CT].

- The CT type is selected at »CT Type«. As soon as one of the available CT types [W\(E\)2](#), ... , [W6](#), [WC1](#), [WC2](#) is selected, the display can be toggled at any time between relative and primary current values.

- »Display of Meas. Values« = “Based on In,relative” — Display of relative current values.

The nominal current is set at »In,relative« as a relative value in units of [[In,min](#)].

- »Display of Meas. Values« = “Primary current values” — Display of primary current values.

The nominal current is set at »CT pri« as a primary current in [A].

These settings can be saved by *Smart view* in a parameter file, just like any setting parameters. (Parameter files have filenames of the form *.WiPara.) This makes it easy to load a set of settings into several WIC1 devices.

Settings via DIP/HEX Switches

WIC1-2, WIC1-3 with the setting »Prot . Settings valid« = “Switches”:

The display options and CT type are set via [Direct Commands](#) within the menu branch [Field Para / CT]. A Direct Command is always immediately transferred to the WIC1 and executed. The result is – comparable to the settings via software described above – that the display of current values changes. However, Direct Commands are **never** saved within a *.WiPara file. Therefore it is necessary to execute them separately on each WIC1, as is the case for the DIP/HEX switches.

The nominal current »CT . In,relative« is set – as a relative value in units of [[In,min](#)] – via the DIP/HEX switches, see also ↪[12.1.2 Setting of the Rated CT current In](#). (By the way, this is an ordinary setting parameter, that would be saved within a *.WiPara file.)

The CT type is set via the Direct Command »*CT Type*«.

- »*CT Type*« = "Relative" — Display of relative current values.
- »*CT Type*« = "WE2 : 16 A ... 56 A", ..., "W6 : 256 A ... 896 A", "WC1", "WC2" — Display of primary current values, based on this CT type.

From this CT type setting, together with the setting of »*In,relative*«, results the nominal current as a primary value, that is displayed at »*CT pri*«.

2.10 Condition Monitoring (Peak Current Ptr, Life Load)

There are two special statistical displays of the phase current values. These are available as table values and in form of special graphical diagrams. Since one of these is also able to issue an alarm signal, these kinds of statistics can also be interpreted as supervision functions:

- »Life Load« evaluates the operating days in dependency on the phase current flow and can (optionally) issue an alarm signal if the WIC1 has been running with too high load for a particular time. See [↔5.14.3 Condition Monitoring - Life Load](#).
- »Peak Current Ptr« mimics an analog pointer instrument by calculating a time-average of the maximum phase current. See [↔5.14.3 Condition Monitoring - Life Load](#).

Behind both types of statistics there is the general idea of checking whether the WIC1 - and therefore the protected object as well - have been under high load.

2.11 Reset

The menu item “Reset” offers commands to reset the latching of a particular state (“selective reset”), and in addition there are some collective resets available:

Type of Latched State	Reset of Several States at the Same Time			Selective Reset
	Automatic Reset	Manual Reset (RESET button at DiggiMEC HMI) (See also ↪3.13.1.1 Front Panel Parts.)	via Digital Input (external reset)	Manually via Direct Control
Alarm-/Trip Cause display on the DiggiMEC HMI	✓	✓	✓	»Rst. LEDs, Fls«
DiggiMEC LEDs	✓	✓	✓	»Rst. LEDs, Fls«
DiggiMEC Outputs/Flag Indicators*	✓	✓	✓	
Thermal Level (of protection function »ThR«, see ↪5.8 ThR - Thermal Overload [49])	—	—	—	»Rst. Thermal Lev.«
Flashing ERROR LED after a device-internal problem	—	—	—	»Rst. Err. LED«, see ↪2.11.2 Notification of a Problem via LED
Reset the WIC1 to factory defaults	—	—	—	»Factory Reset«, see ↪2.12 Reset to Factory Defaults

* The WIC1 has an impulse output for setting a flag indicator, but it lacks an output for resetting it. Therefore only the DiggiMEC flag indicators can be set **and** reset by the WIC1. However, the reset of the DiggiMEC flag indicators is functional only if the WIC1 settings have specified which DiggiMEC variant is connected; the related parameter is [Device planning / WIC1 + DiggiMEC] »DiggiMEC . Mode«. In addition, DiggiMEC flag indicators can also be switched mechanically, by hand. (See ↪3.13.3 Flag Indicator / Output Relays Settings (DiggiMEC).) But note that such a mechanical change of state is **not** signaled back to the WIC1.

NOTICE!



There is **no** latching of the WIC1-LED „Pickup/Trip“ (after a protection pickup / trip). Therefore there is no need for resetting it.

2.11.1 Automatic Reset

For some states it is possible to activate an automatic reset of the latching. This means that their latched state gets reset with each new (General) Pickup signal »Prot . Pickup« – and optionally once again after a particular timer, that is started when the (General) Pickup drops off, has elapsed.

Independent of this, it is also possible at any time to manually reset via DiggiMEC »RESET« key or via a digital input signal.

The following settings are available for this:

- For the latching of DiggiMEC flag indicators / output relays, [Device Para / DiggiMEC / FI / BO] »*BO x latching*« = “Latch. w. Auto-Reset”

(See also [↔3.13.3.1 Latching.](#))

- For the latching of DiggiMEC LEDs, [Device Para / DiggiMEC / LEDs] »*LED x latching*« = “Latch. w. Auto-Reset”

See also [↔3.11.3 Latching of the DiggiMEC LEDs.](#))

- The behavior of the automatic reset itself is set at [Device Para / Reset] »*Def. Autom. Reset*«

Note that the automatic reset is closely related to the (General) Pickup signal »Prot . Pickup«, and therefore we recommend to always use it only with states that indicate any protection pickup or trip.

If, however, an automatic reset is assigned to a state that is not related to any pickup or trip, the resulting reset behavior might be surprising (although it is exactly what one needs for real-life applications): Every protection pickup also issues the signal »Prot . Pickup«, see [↔5.1 »Prot« – General Protection Module](#), and this signal starts the automatic reset. This means, of course, that all states (that are set to latching with automatic reset) get reset, and moreover, states that are assigned to this new protection pickup, get set (again). If the automatic reset is configured with a timer stage, for instance »*Def. Autom. Reset*« = “New Pickup or After 1 h”, then the timer starts when the signal »Prot . Pickup« drops off. And after the timer has elapsed, i. e. after one hour, all states (that are set to latching with automatic reset) get reset (again). So, unless there will be another protection pickup within this hour the result is that after one hour all states (that are set to latching with automatic reset) are reset.

But now let us consider a state, that is set to latching with automatic reset, but is assigned to some signal that is in no way related to any protection pickup or trip. This state would not get reset after one hour, because the timer stage always only starts when »Prot . Pickup« drops off. This means that only when a protection pickup should occur, will this state be reset (and once again one hour after the pickup drops off).

2.11.2 Notification of a Problem via LED

The second, red LED of the WIC1 can notify you of a device-internal problem by flashing red, see [↪“The »System« LED\(s\) – “Ready”, “Error””](#). Contrast to a constant red illumination the flashing means that the overall protection functionality is fully active and not affected by the problem. Therefore it is possible to reset (“acknowledge”) the flashing LED.

This is done with the following Direct Control:

- [Operation / Reset] »Rst. Err. LED«

Although the protection functionality is essentially active it is apparently advisable to check for the problem that has caused the flashing LED, and for potential solutions. Check the entries in the Fault Recorder ([↪6 Fault/Alarm Recorder](#)) and the list of potential problems in [↪11 Troubleshooting](#).

2.12 Reset to Factory Defaults

This Direct Control resets all parameters to their respective factory default:

- [Service / General] »Factory Reset«

This is the same functionality as keeping the DiggiMEC key »X« pressed during power-on, see [↪3.13.1.3 Special Keys During Power-on](#).

WARNING!



All parameter settings as well as the [password](#) will be reset. All records will be deleted and statistic values and counters will be reset.

Parameters that can be set via DIP/HEX switches will get the values as defined by the switches.

Exception: The operation hours counter is preserved.

Resetting to factory default is also required if a WIC1 that has previously been configured via Smart view (PC) / DiggiMEC is to be set back to settings via DIP/HEX switches; see [↪Chapter 2.2.2](#).

2.13 Security

Security-Related Messages

Enter [Operation / Self-Supervision / Messages] to access the list of [Self-Supervision Messages](#). This is a special Recorder that collects device-internal messages of various types, including security-related events. It is recommended to check these entries from time to time.

2.13.1 Password

The WIC1 supports an access password, that is required for any changes to the device settings (via *Smart view* (PC) or DiggiMEC).

The menu item [Device Para / Security / Password] allows for setting an individual password. It is also possible to set it to an empty/blank text, and in this case the password query is skipped.

Up to four digits (i. e. only "0"... "9" are allowed for each position) are allowed for the password. The factory default is: »**1234**«

On the DiggiMEC panel, the password is entered the same way as any numerical setting value, i. e. via navigation keys "◀" (Left), "▶" (Right) for the position (= selection of the position/digit within the password) and "▲" (Up), "▼" (Down) for increasing/decreasing the digit. The Enter key »↵« confirms the entered password. A Smart view user enters the password simply via the PC keyboard.

Password Forgotten

By pressing the »X« key during a cold restart a reset dialog is launched, see also [↪3.13.1.3 Special Keys During Power-on](#). It allows for resetting all settings, including password, to the respective default.

This is the same functionality as the Direct Control [Service / General] »Factory Reset«, see [↪2.12 Reset to Factory Defaults](#).

2.14 Date and Time, Counters

The WIC1 lacks a real-time clock. This is an intended construction aspect, because a real-time clock would have required a buffer battery and even communication protocols for time synchronization. The WIC1, however, has been designed to operate in a remote station for years without special maintenance (like exchanging a battery).

Alternatively, to enable chronological ordering of events, the WIC1 features several timers and counters. Some of them are also logged for each entry in the [fault recorder](#) and the [self-supervision messages](#). This is further explained in the table below.

Value	Menu Path	Description
»Op. Hours«	[Operation / Count and RevData / WIC1]	Device operation hours counter, that shows for how long the device has been operating since the last restart.
»Actual Runtime (Device Startup No.)«	[Operation / Time / Uptime] Also as timestamp for events under: <ul style="list-style-type: none"> [Operation / Self-Supervision / Messages] [Operation / Recorders / Fault/Alarm Rec.] 	Actual runtime of the device since last startup and the total startup counter of the device.
»Fault No.«	[Operation / Count and RevData / Prot] Also logged for events under: <ul style="list-style-type: none"> [Operation / Recorders / Fault/Alarm Rec.] 	Fault counter of the device.
»Alarm No.«	[Operation / Count and RevData / Prot] Also logged for events under: <ul style="list-style-type: none"> [Operation / Recorders / Fault/Alarm Rec.] 	Alarm counter of the device.

3 Hardware

3.1 Overview of Elements and Connectors

NOTICE!

! The controls and connectors, that the WIC1 is fitted with, depends on the [Order Form](#) of the WIC1.

Front Side

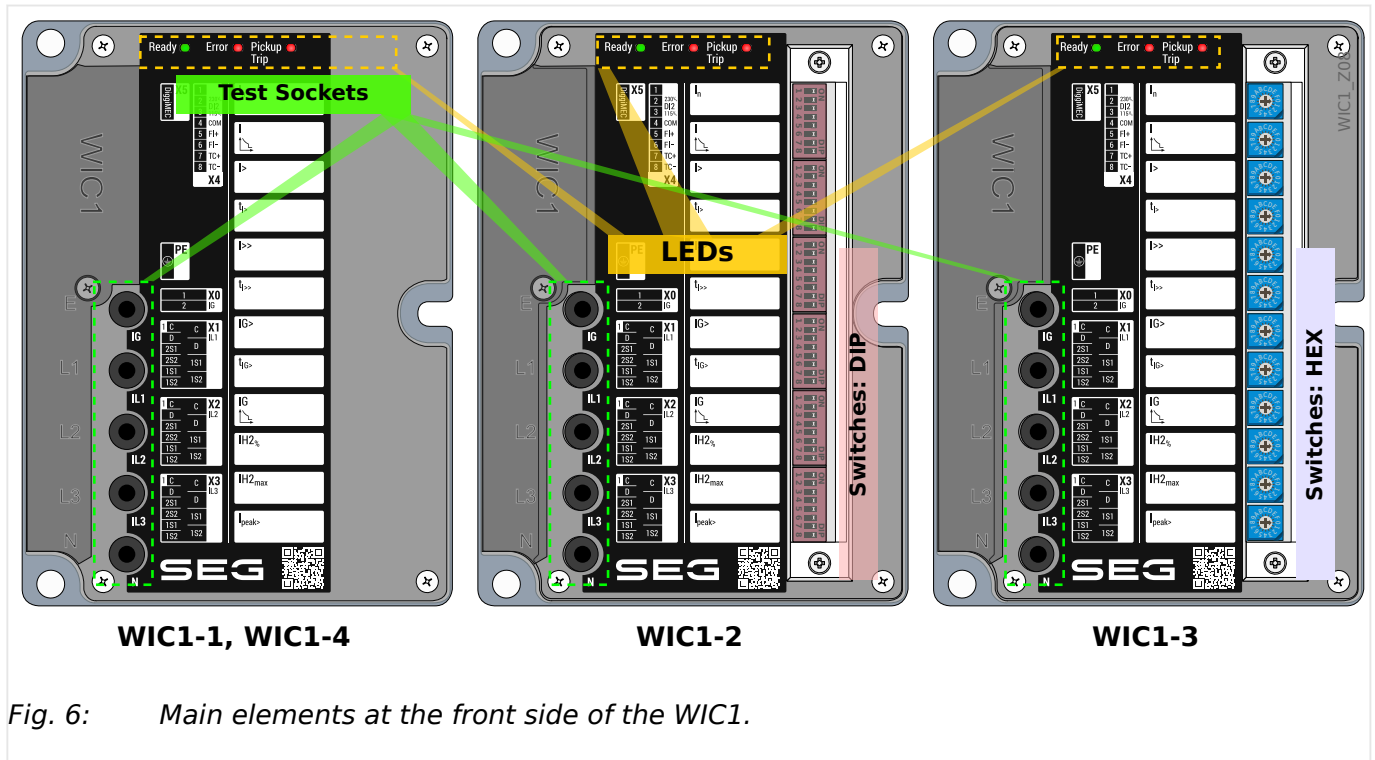
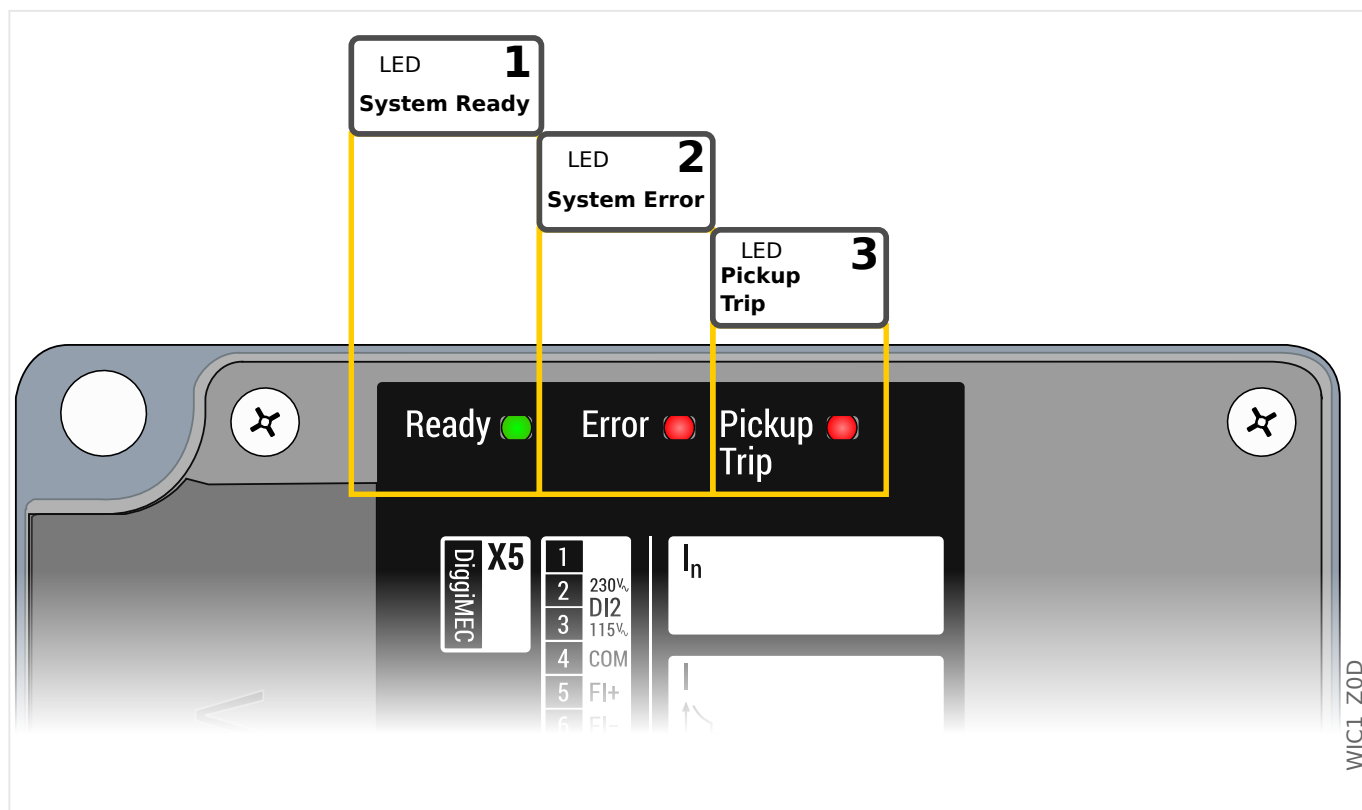

Fig. 6: Main elements at the front side of the WIC1.

The front side of the WIC1 is equipped with LEDs (for operation and alarm signals, see →3.11 LEDs) and several test sockets, see →8.1.4.1 Test Windings, Test Sockets.

LEDs

- LED 1** **System Ready:** This LED means: “Ready to Trip”. It is shining constantly green as soon as the WIC1 has (finished its booting process **and** and) loaded sufficient electrical energy for triggering the Trip impulse output. Details see [↔“The »System« LED\(s\) - “Ready”, “Error””](#) and [↔3.10 Outputs \(Trip Coil, Flag Indicator, Relay Output\)](#).
- LED 2** **System Error:** This LED is flashing red or shining constantly red after a system error has occurred. Depending on the type and severity of this error either the non-protection functions are deactivated - protection is still operating - or only the (hardware-based) backup protection is available. Details see [↔“The »System« LED\(s\) - “Ready”, “Error””](#) and [↔7.3 Backup Protection / Self-Supervision](#).
- LED 3** **Pickup / Trip:** This LED is flashing red during a (General) Pickup, and it is shining constantly red while a (General) Trip occurs. See also [↔3.11.1 WIC1-LED for “Pickup / TripCmd”](#) and [↔5.1 »Prot« - General Protection Module](#).

Device Variants with Configuration Switches

- Variant WIC1-2 is additionally equipped with DIP switches for configuration of protection parameters, see [↔12.1.1 Settings via DIP / HEX Switches \(WIC1-2, WIC1-3\)](#).
- Variant WIC1-3 is additionally equipped with HEX switches for configuration of protection parameters, see.

Lateral Terminals

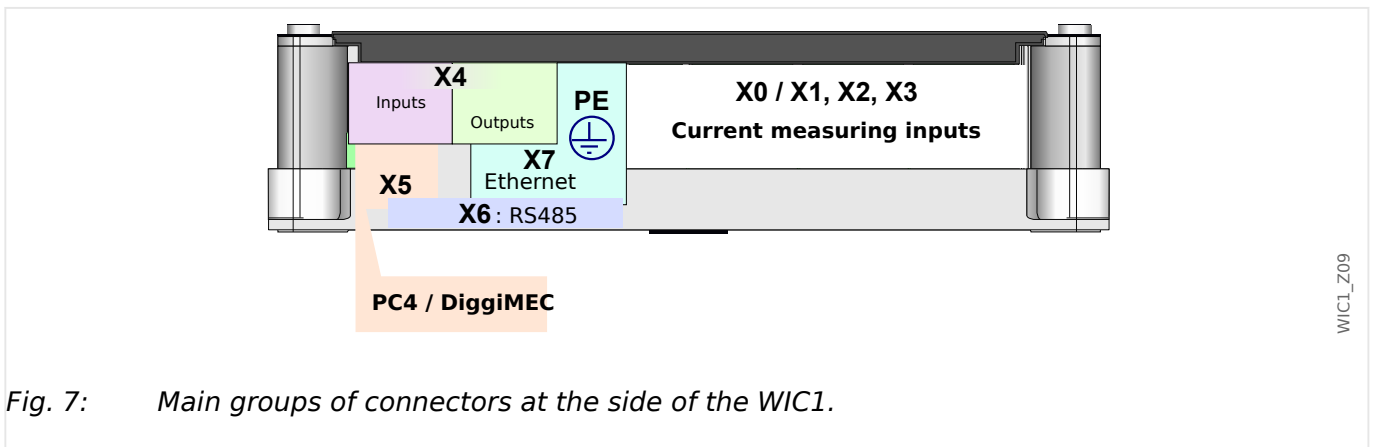

Fig. 7: Main groups of connectors at the side of the WIC1.

The WIC1 has all connectors located at one side of the housing, so that it is convenient to connect the required cables.

3.1.1 Terminals, Screws and Torques

CAUTION!



Be careful. Do not overtighten the mountings nuts of the relay. Check the torque by means of a torque wrench with respect to the max. torque values in the table. Wrong torques, especially over-tightening the mounting nuts, can cause mal-functioning of device and application, or even damage the device.

Slot	Tightening Torques of the Screws	Screw Type	Description
PE	1.6 Nm (14.2 lb·in)	nut, 7 mm	Screw-type connector for Protective Earth. See ↔3.1.2 Grounding .
X0	0.5 Nm (4.4 lb·in)	M3 slotted	Measuring input for ground (earth) current (for some order options) — See ↔3.4 Phase and Ground Current Measuring Inputs .
X1, X2, X3	Inputs for WIC1 CTs: 0.5 Nm (4.4 lb·in)	Inputs for WIC1 CTs: M3 slotted	Measuring inputs for phase currents — See ↔3.4 Phase and Ground Current Measuring Inputs .
X4	0.5 Nm (4.4 lb·in)	M3 slotted	Pin assignments depending on the order option , for example: <ul style="list-style-type: none"> • Impulse signal outputs for a trip coil and for a flag indicator — See ↔3.10 Outputs (Trip Coil, Flag Indicator, Relay Output). • Only some variants of WIC1-1... / WIC1-2... / WIC1-3...: Input e. g. for an external trip signal — See ↔3.5 Digital Input (only WIC1-1... / WIC1-2... / WIC1-3...) • Only WIC1-4...: Digital Inputs incl. additional auxiliary power supply — See ↔3.6 Additional Power Supply and Digital Inputs (WIC1-4... only)
X5	—	—	RJ45 connection to PC4 adapter or DigiMEC. Ethernet CAT3 cable or better, but beware, this is not an Ethernet connection! Beware, crossover cables must not be used! See also ↔3.12 PC4 adapter - PC Interface for WIC1 and ↔3.13 DigiMEC® - Nano HMI with optional Flag Indicators and Output Relays .
X6	0.22 Nm (1.9 lb·in), except: two screws for fixing the connector: 0.3 Nm (2.6 lb·in)	M3 slotted, except: two screws for fixing the connector: M2 slotted	Only some variants of WIC1-4: RS485 connector for SCADA communication.
X7	—	—	Only some variants of WIC1-4: RJ45 or fiber optics connector for Ethernet-based SCADA communication.
—	0.3 Nm (2.6 lb·in)	M3 crosshead	Plastic cover for protecting and covering the lateral terminals, fastened with one non-losable screw.
—	0.6 Nm (5.3 lb·in)	M3 crosshead	Only for variants of WIC1-2, WIC1-3: Plastic cover for the DIP/HEX switches, fastened with two non-losable screws.

3.1.2 Grounding

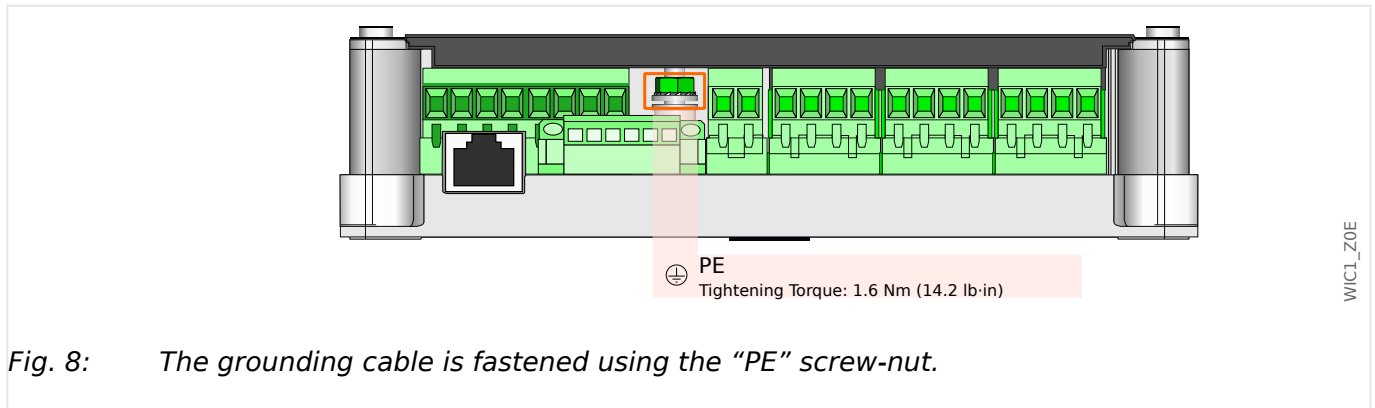

Fig. 8: The grounding cable is fastened using the “PE” screw-nut.

WARNING!



The housing must be carefully grounded.

- Connect a ground cable (protective earth, 4 to 6 mm² [AWG 11–9], tightening torque 1.6 Nm [14.2 lb-in]) to the housing, using the nut that is marked with the “PE” symbol. (See also [↔3.1.2.1 Nut “PE” for Grounding.](#))

All grounding connections (i. e. protective earth) must be low-inductance, i. e. as short as possible, and national standards – if applicable – must be followed.

CAUTION!



The devices are very sensitive to electro-static discharges.

A tabular overview of all terminals can be found in [↔3.1.1 Terminals, Screws and Torques](#) zu finden.

CAUTION!



The measuring winding (terminals S1 and S2, and – if available – S3, S4) of the CTs must not be earthed, otherwise the measurement results are distorted, ensuring in erratic behavior of the WIC1.

3.1.2.1 Nut "PE" for Grounding

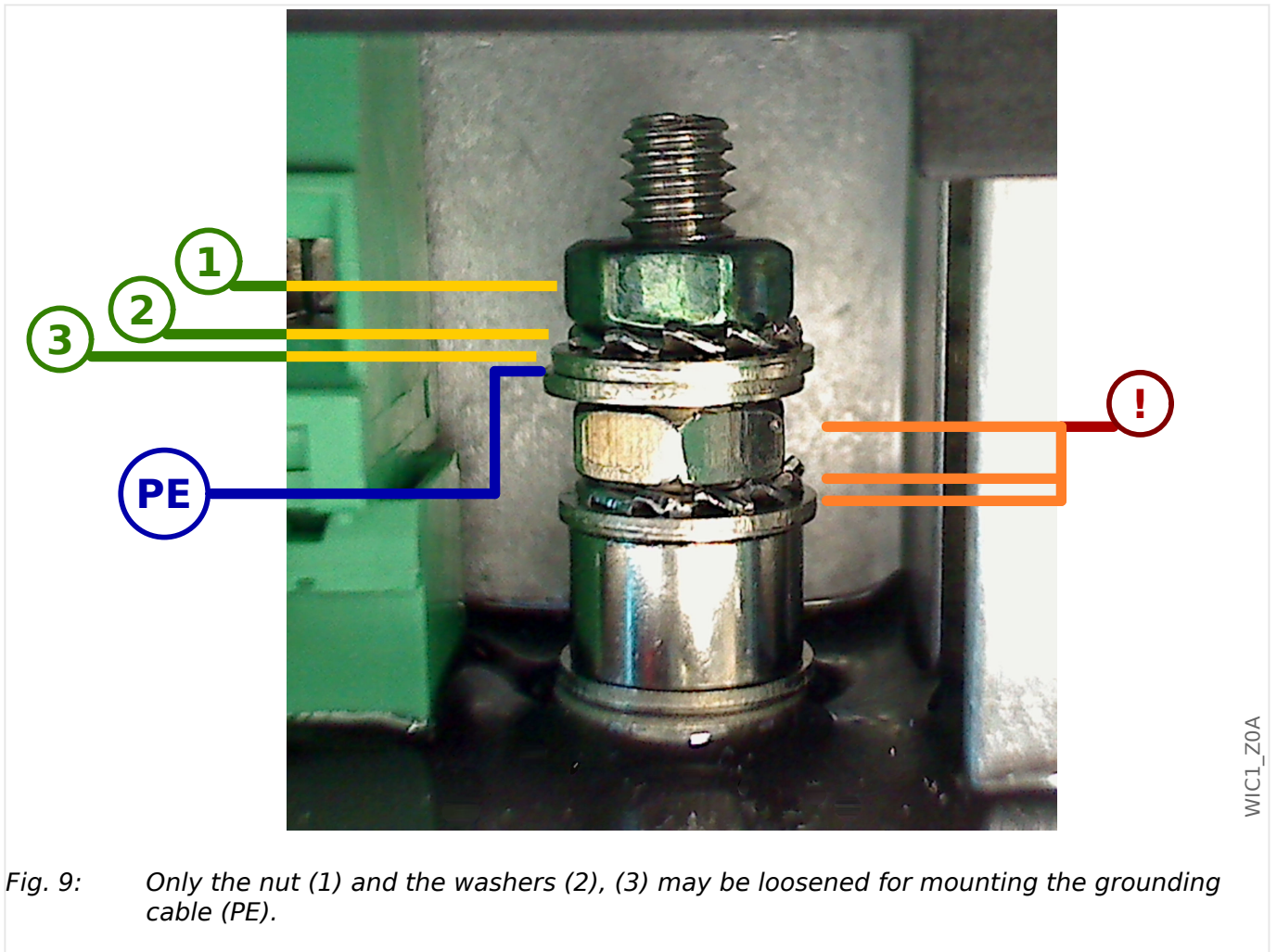

Fig. 9: Only the nut (1) and the washers (2), (3) may be loosened for mounting the grounding cable (PE).

The grounding cable has to be furnished with a ring-terminal, that gets fastened between two washers, see the blue "PE" marking in the image above.

First you have to remove the nut (1), the serrated lock washer (2) and the upper washer (3), then mount the eye of the ring-terminal, finally fasten the nut and washers again (tightening torque: 1.6 Nm [14.2 lb·in]).

The lower parts that are marked with the red (!) in the image **must** be kept fixed all the time!

3.2 Dimension Drawings

3.2.1 WIC1 Dimension Drawings

All WIC1 variants are of the same standardized design. Therefore the dimension diagrams below are not meant to be restricted to a particular variant.

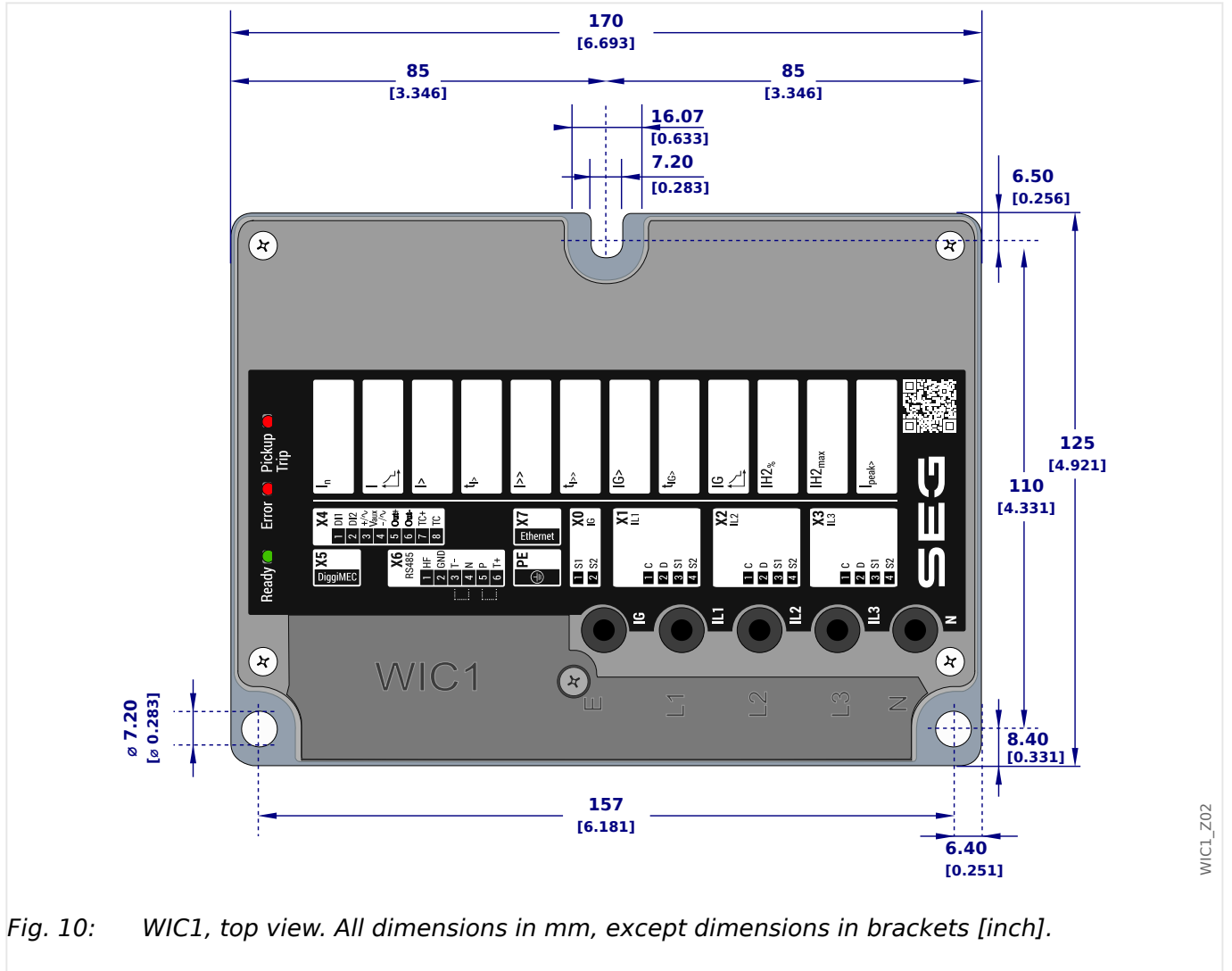

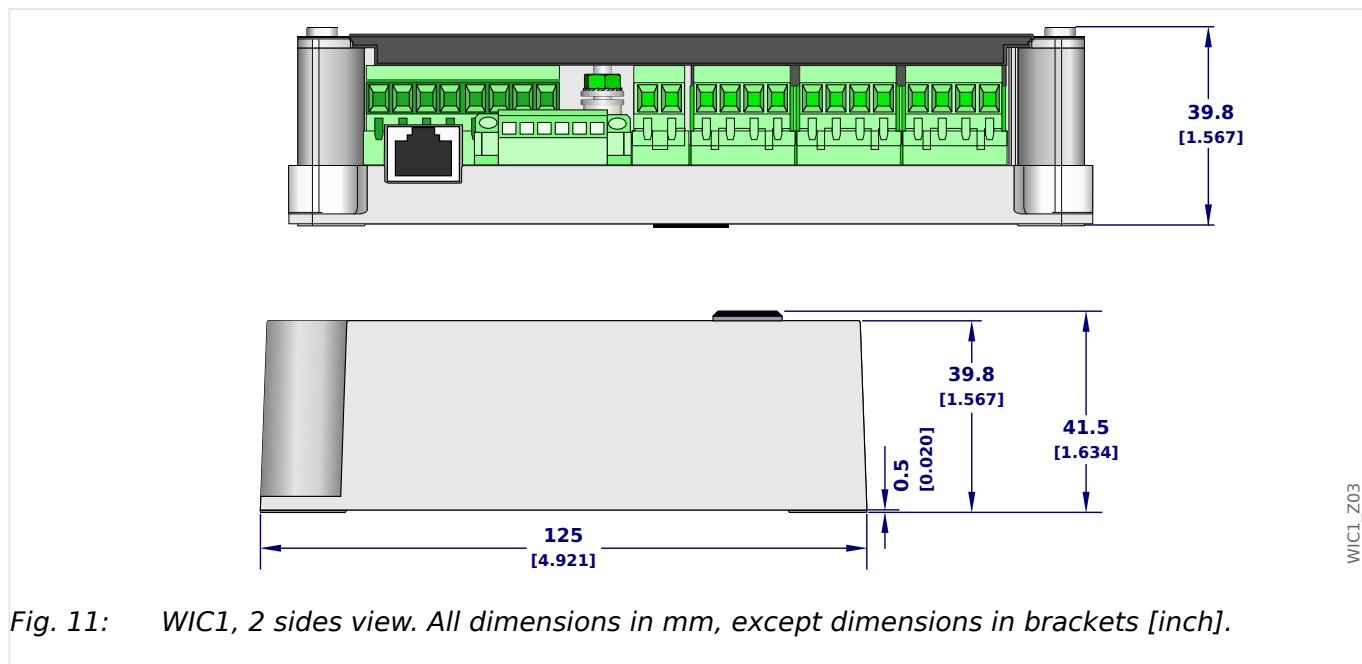

Fig. 11: WIC1, 2 sides view. All dimensions in mm, except dimensions in brackets [inch].

NOTICE!



Dependent on the connection method of the SCADA system used the needed space (width) differs. If, for instance, a device variant with an RS485-plug is used, it enlarges the width dimension.

3.2.2 DiggiMEC Dimension Drawings

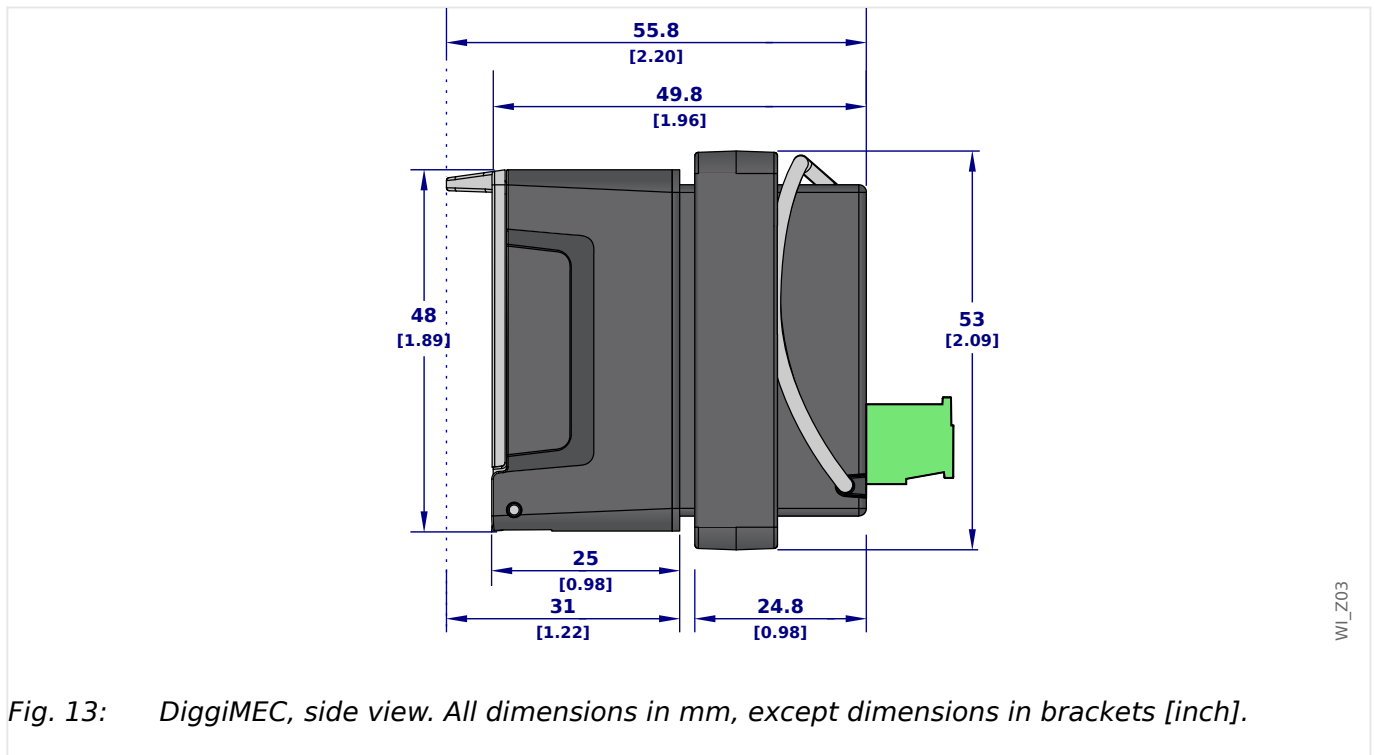
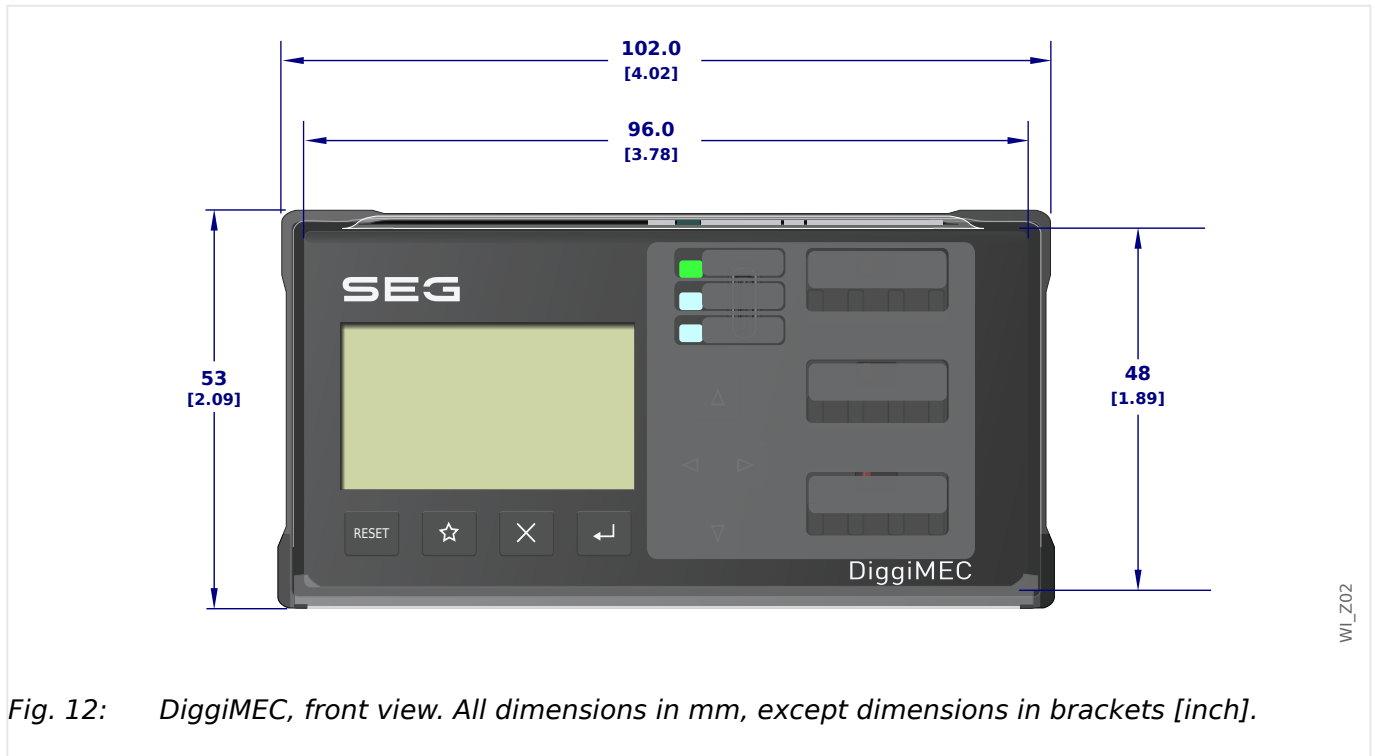

Installation Diagram - Cutout for Door Mounting of the DiggiMEC

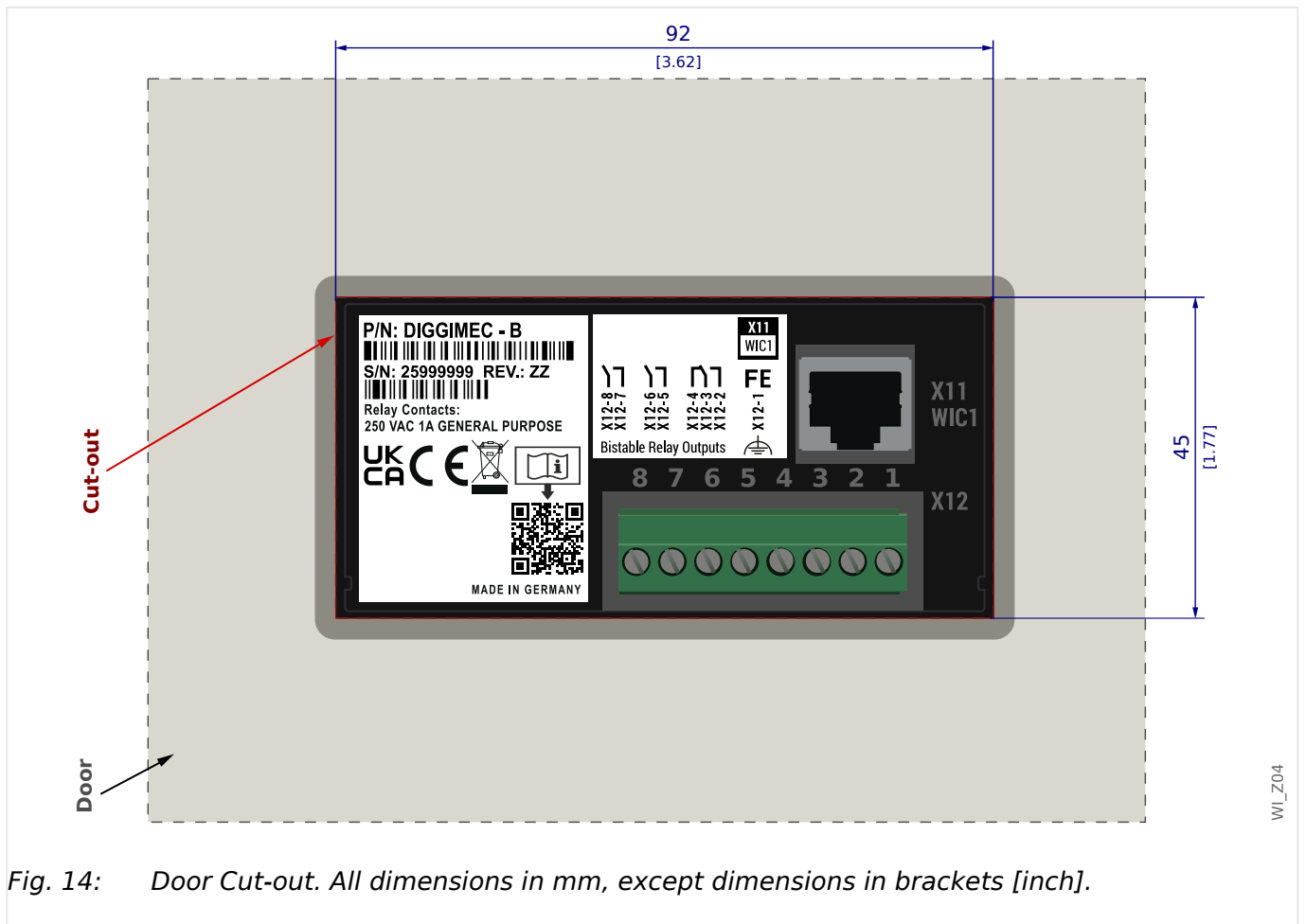

The DiggiMEC can be mounted into a standard door cutout, that is already available by default with most cabinets.

The rear side (→3.13.2 DiggiMEC Connectors) features an RJ45 plug: It may only be used to connect the DiggiMEC with a WIC1.

3.2.3 Dimension Drawings of the WIC1-Compatible Current Transformers

WIC1-Wx CTs (Construction Type 2)

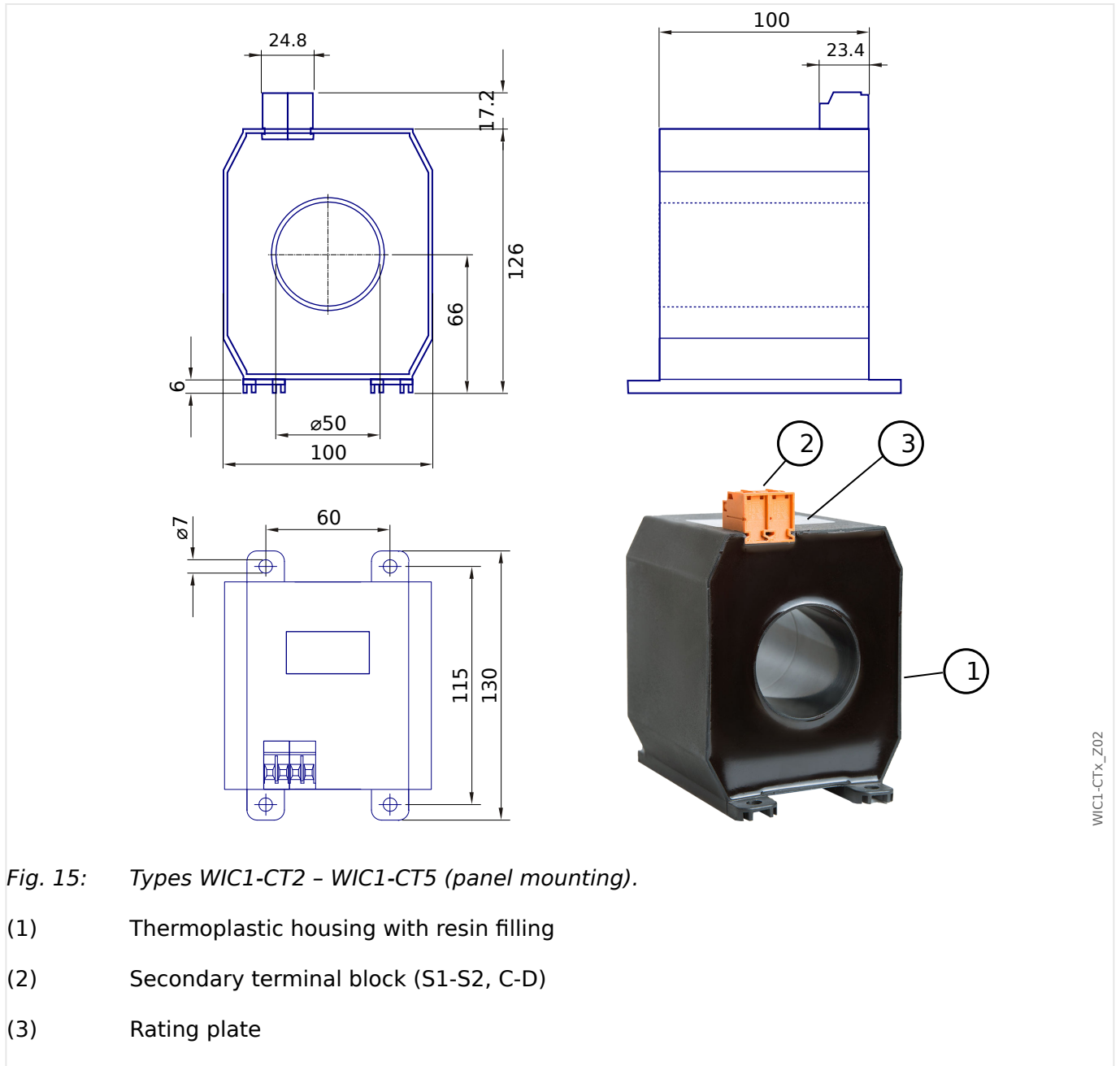

WIC1-CTx_Z02

WIC1-Wx CTs (Construction Type 1)

Fig. 16: Types WIC1-W2AS1 - WIC1-W5AS1 SVA105 housing (panel mounting).

NOTICE!

Prior revisions of these CTs used a slightly smaller SVA100 housing with different, but compatible, connectors. Besides, the CTs did not change and provide similar performance and electrical behavior. The dimension diagrams for SVA100 housing can still be accessed via older manuals until R2.2.

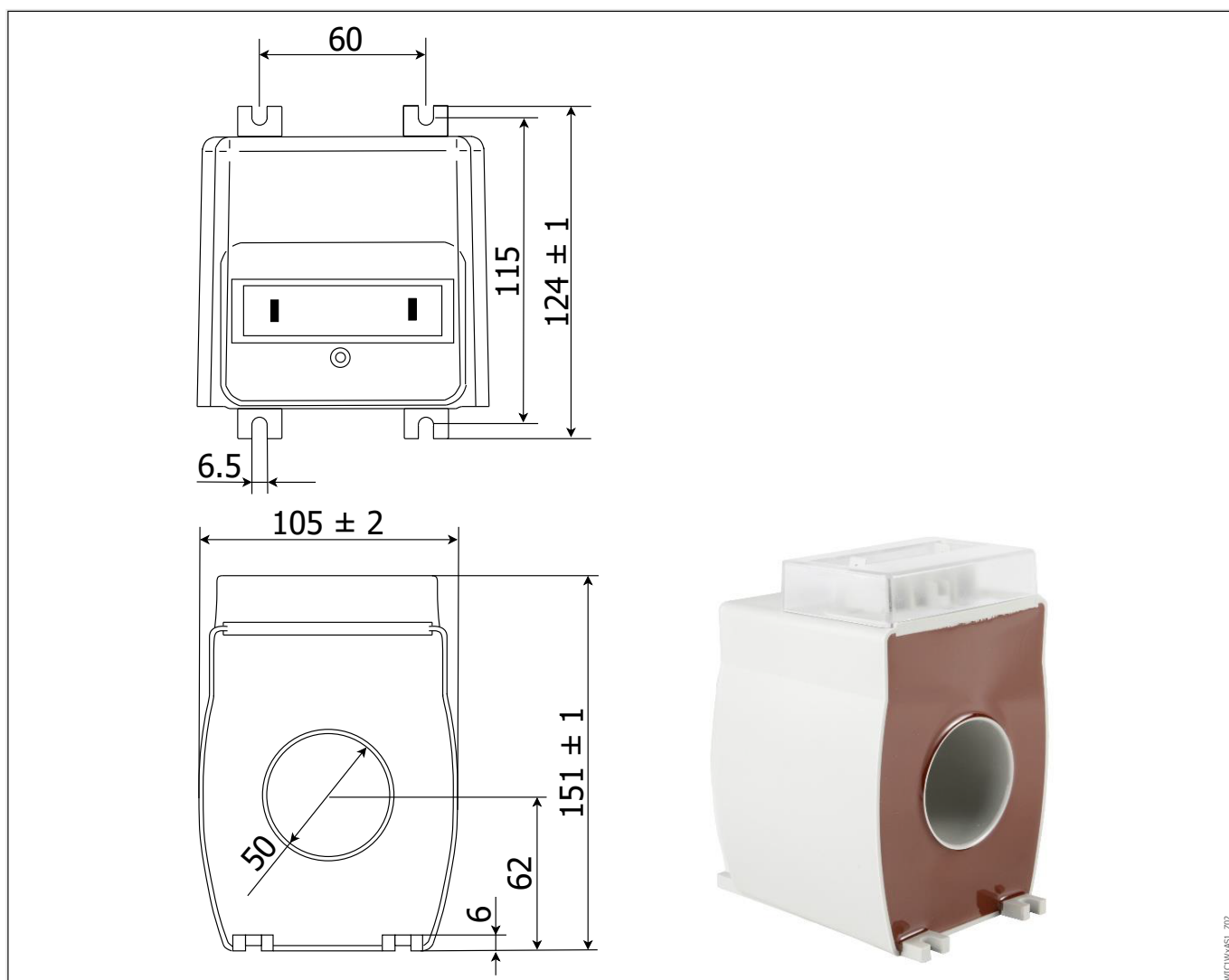
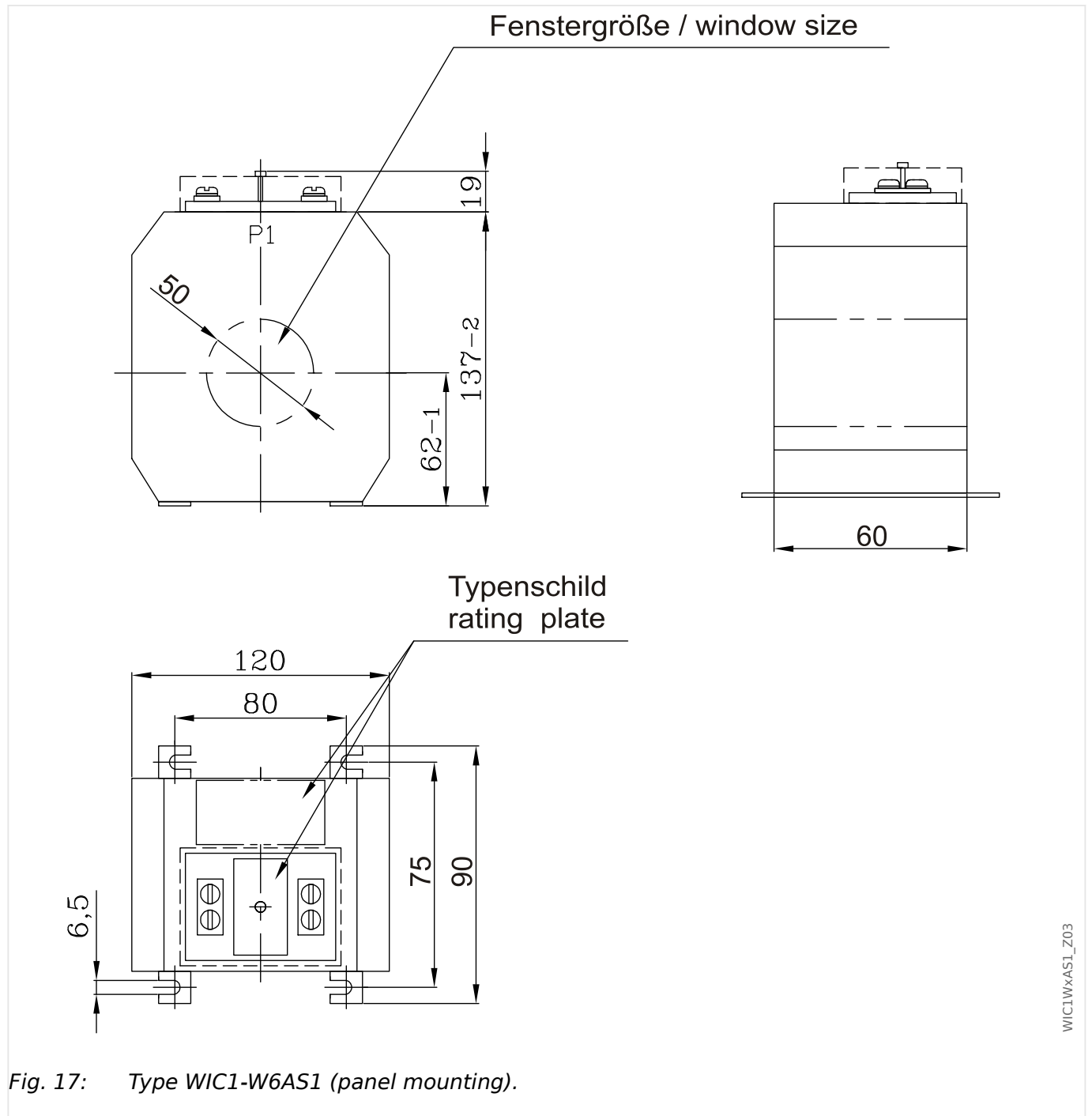

WIC1W6AS1_Z03

Fig. 17: Type WIC1-W6AS1 (panel mounting).

WIC1-WC Converter CTs for 1A / 5A

Fig. 18: Converter CT, WIC1-WC1-1A / WIC1-WC1-5A / WIC1-WC2-1A (panel mounting).

- (1) Thermoplastic housing with resin filling
- (2) Connection cables, 2.5 mm², length = 3000 mm
- (3) Rating plate

The WC Converter CTs contain converters for all three phases in one single housing.

WARNING!

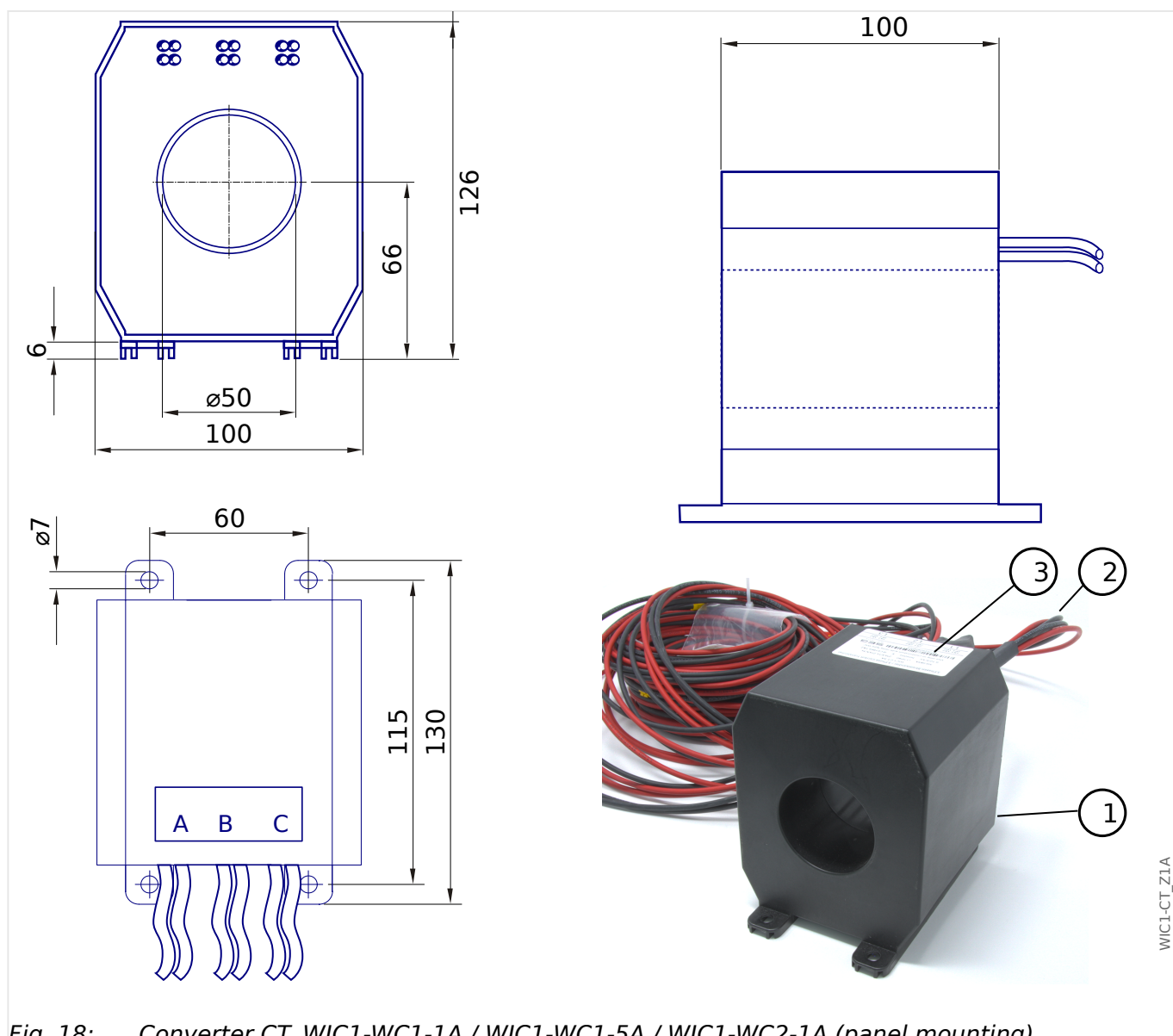
Due to technical constraints with respect to construction, the Converter CT has a window, just like the feed-through of a standard CT. But it is not permitted to mount an MV / primary current cable through this Converter CT window!

Ignoring this can result in dangerous voltages at the contacts, and due to wrong measuring values there would not be any effective protection of your equipment.

NOTICE!



Please note also these peculiarity, that are inherent to the construction of the Converter CTs:

- The housing (see [↪Fig. 18](#)) contains three Converter CTs, so that all three phase currents are covered. Therefore you need to buy only one unit, see also [↪“WIC1-WC Converter CTs for 1 A or 5 A”](#).
- There are no test windings. Therefore the test sockets of the WIC1 **cannot** be used with the Converter CTs.

3.2.4 Dimension Drawing of the Flag Indicators WI1SZ4, WI1SZ5

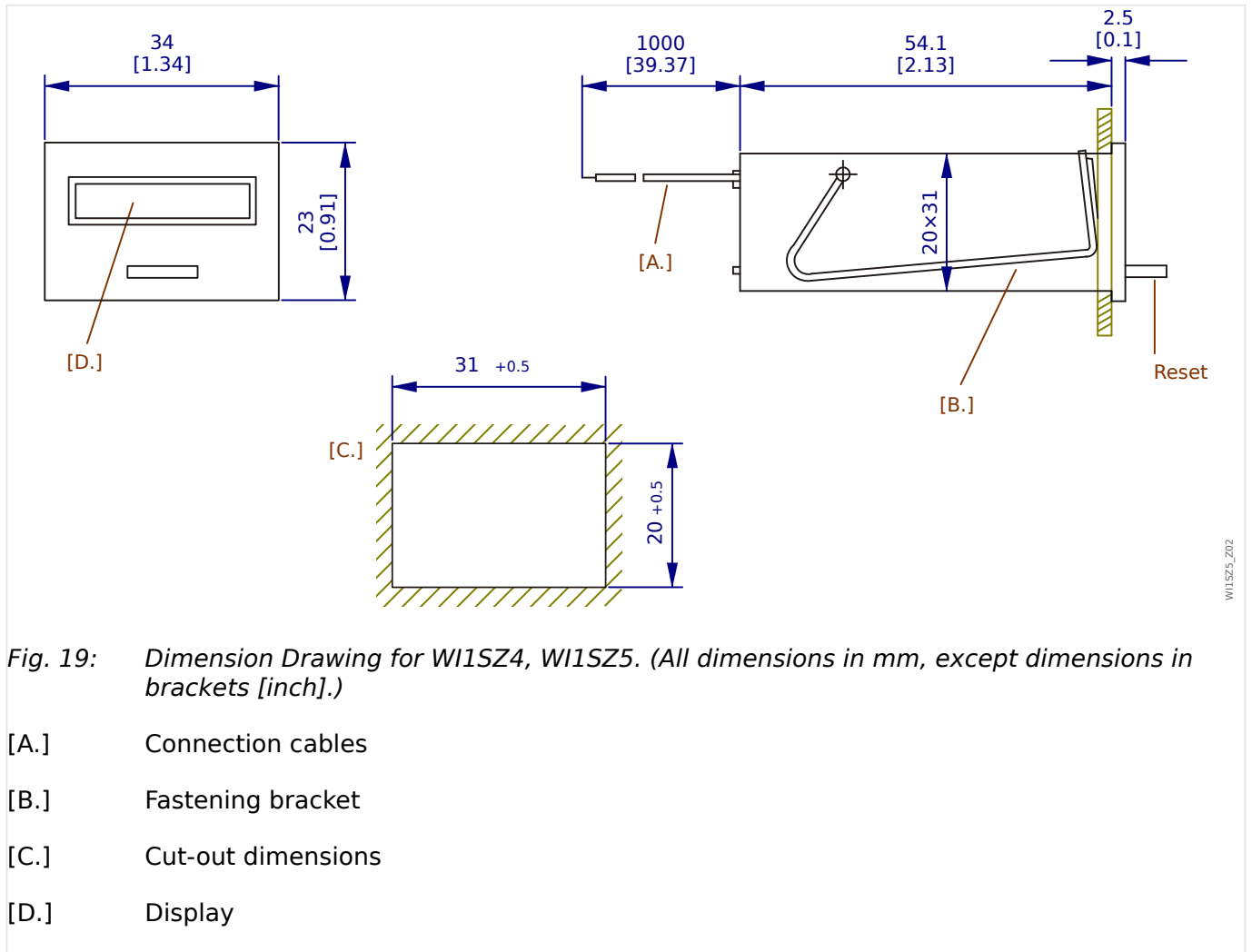

Fig. 19: Dimension Drawing for WI1SZ4, WI1SZ5. (All dimensions in mm, except dimensions in brackets [inch].)

- [A.] Connection cables
- [B.] Fastening bracket
- [C.] Cut-out dimensions
- [D.] Display

3.3 Current Transformers (CTs)

DANGER!



The terminal block for connection to the current transformers is not a shorting block. Therefore always short-circuit current transformers before loosening the terminals.

Ignoring this can result in dangerous voltages at the open contacts (up to dozens of kilovolts depending on the CT type).

DANGER!



The WIC1-compatible current transformers are dimensioned for nominal voltages < 1000 V. This means for an application in MV-switchboards (i. e. voltages < 36 kV) that these current transformers may only be used with insulated primary conductors, for example cables, with appropriate insulation resistance against earth. These current transformers are not allowed to be used for non-insulated primary conductors > 1000 V against ground (earth).

In addition, the medium voltage cables, whose phase currents shall be measured via the CTs, must be furnished with a grounded/earthed shielding.

Ignoring this can result in dangerous voltages at the open contacts (up to dozens of kilovolts depending on the CT type).

CAUTION!



It is not permissible to connect common CTs with secondary currents of 1 A or 5 A to the measuring inputs.



For the test winding, see the [Commissioning](#) chapter, in particular [↪8.1.4.1 Test Windings, Test Sockets](#).

Introduction

The WIC1 is designed to use the CTs for the power supply of itself besides retrieving current measurement values. This requires on one side to deliver enough power for operation of the device while maintaining a high accuracy of the current measurement. WIC1-compatible CTs are designed to meet these special requirements, which is the reason why the WIC1 and compatible CTs must be understood as one system. These CTs have a significantly lower secondary current magnitude compared to 1 / 5 A standard CTs.

There are two types of WIC1-compatible CTs:

The [WIC1-Wx CTs](#) can be used for direct measurement of primary currents. There are multiple variants available to cover a wide range of primary currents. For example, the W2 CT supports a range for primary rated currents between 16 A and 56 A.

The [WIC1-WC CTs](#) can **not** be used for primary current measurement, because they are designed as converters between 1 / 5 A standard CTs and the WIC1 to deliver the necessary lower current magnitudes for the phase current measurement inputs.

Definitions

For the understanding of the WIC1 it is essential to understand a few definitions related to the secondary current of the WIC1-compatible CTs:

- **$I_{n,min}$ (sec.) = 0.083 A**: This current flows at the minimum setting of rated current for a Wx CT (e.g 16 A on the primary side for a W2 CT).
- **$I_{n,max}$ (sec.) = 0.29 A**: This current flows at the maximum setting of rated current for a Wx CT (e.g 56 A on the primary side for a W2 CT).
- $I_{n,max} = 3.5 \cdot I_{n,min}$

Besides definition of the rated current range, $I_{n,min}$ and $I_{n,max}$ are used as a reference to define thresholds related to the secondary side of the WIC1. For example, the secondary minimum 1ph current that is necessary to supply the WIC1 with enough power to operate is 29 mA or 0.35 $I_{n,min}$. For the W2 CT it is 0.35 $I_{n,min} = 0.35 \cdot 16 \text{ A} = 5.6 \text{ A}$ on the primary side.

The current ranges and definitions for the WIC1 and compatible CTs are shown in [↔Table](#) .

Special Case WC CTs

The WC CTs do not have a range for the rated current because they are connected to standard CTs which are fixed to 1 / 5 A current.

- **WC1 CTs**: These CTs are designed to deliver 0.083 A or $I_{n,min}$ at rated current of the standard CT (1 / 5 A)
 - $I_n = I_{n,min}$
 - $I_{n,max}$ is only a theoretical value here
- **WC2 CTs**: These CTs are designed to deliver 0.29 A or $I_{n,max}$ at rated current of the standard CT (1 / 5 A)
 - $I_n = 3.48 I_{n,min} \approx I_{n,max}$
 - $I_{n,min}$ is only a theoretical value here

CT Type	3p min *1) (Min. Supply in 3 Phases) [A]	1p min *1) (Min. Supply in 1 Phase) [A]	Range of In		Max. current (meas. range)*2) [A]	Max. continuous thermal withstand current [A]	Max. 1 s thermal withstand current [A]
			In,min [A]	In,max [A]			
Secondary current*3)	0.021	0.029	0.083	0.29	5.83	0.725	-
W2	4	5.6	16	56	1120	140	25000
WE2	4	5.6	16	56	1120	140	25000
W3	8	1.2	32	112	2240	280	25000
W4	16	22.4	64	224	4480	560	25000
W5	32	44.8	128	448	8960	1120	25000
W6	64	89.6	256	896	17920	2240	25000
WC1-1A (In = In,min)	0.25	0.35	1	3.5*4)	70	2.5	100
WC1-5A (In = In,min)	1.25	1.75	5	17.5*4)	350	12.5	500
WC2-1A (In ≈ In,max)	0.07	0.1	0.29*4)	1	20	2.5	100

- *1) See also [Technical Data](#), ↪[10.1.6 Power Supply](#).
- *2) The measuring range of the phase current inputs ends here. Beyond this value there is no more increase of the device-internal current measurement value. Nevertheless, short circuit currents may exceed this threshold without compromising the functionality of the device as long as the thermal withstand capability is respected.
- *3) Secondary current of the WIC1 CTs which is fed into the phase current measuring inputs.
- *4) For the WC CTs this is only a theoretical value to supply information related to secondary values (e.g. the 3p min supply current). The WC CTs do not have a settable range for rated input current as they are fixed to 1 / 5 A. For more information refer to ↪[“Definitions”](#) and ↪[3.3.2 WIC1-WC Converter CTs \(1 A / 5 A Measurement\)](#).

Settings - CT & Rated Current

The rated current of the protected object can be set either:

- Primary: Set »CT Type« to connected CT and primary current in A with »CT pri«.
- Relative: Set »CT Type« = “Relative” and the current as a multiple of In,min with »In,relative«.

Both options are available via Software Settings. For [DIP / HEX switches](#) (WIC1-2, WIC1-3 only) the relative setting must be used.

For the WIC1-WC Converter CTs, see also the notes under ↪[“Settings”](#).

3.3.1 WIC1-Wx CTs (Primary Measurement)

3.3.1.1 Current Ranges of the WIC1-Wx-CTs

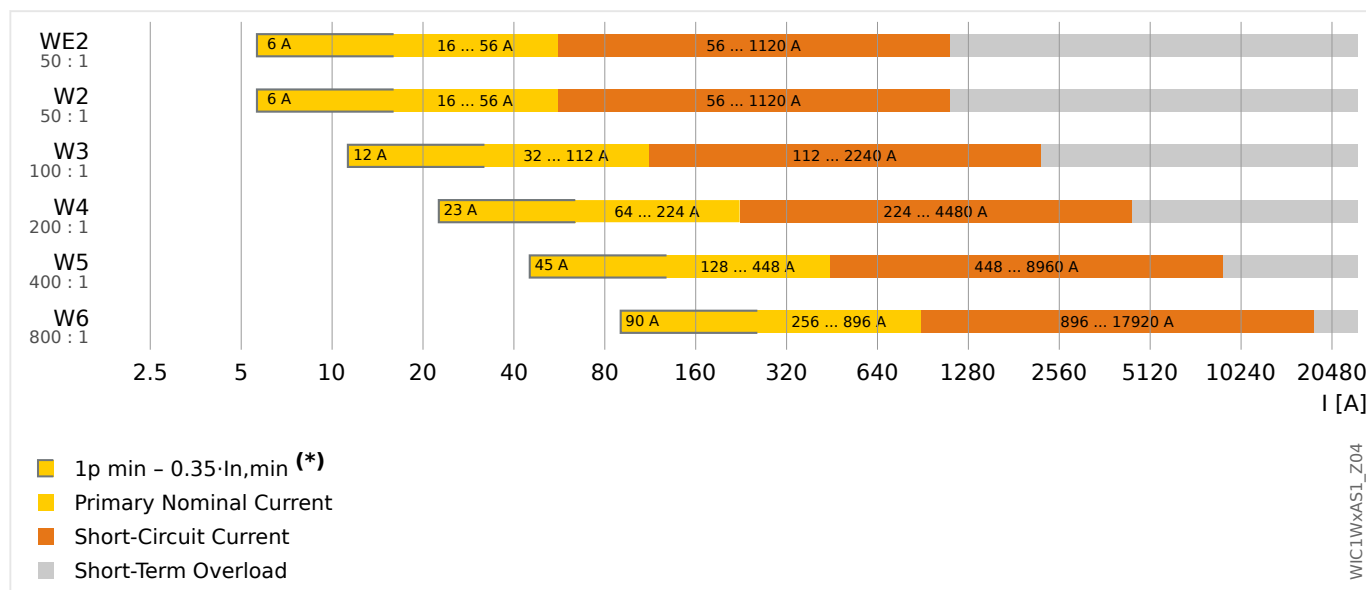

Fig. 20: Current Ranges for the WIC1-compatible CTs.

* 1p min: Via Smart view (PC) / DiggiMEC, the WIC1 can be functional starting at 0.35 $I_{n,min}$ (1-phase supply). The related setting values, however, cannot be set via DIP/HEX switches.

The WIC1-Wx CTs are designed for direct measurement of primary currents. Each CT type covers a range of primary current. This is shown in the figure above.

The CT for each application should be selected according the primary rated current of the protected object, which is explained under [↔3.3.1.2 Selection of the CT Transformation Voltage Ratio](#).

3.3.1.2 Selection of the CT Transformation Voltage Ratio

Selection of the CT suitable for the WIC1 depends on the rated current of the transformer to be protected. It can be calculated according to the following formula:

$$I_n = \frac{S_n}{\sqrt{3} \cdot V_n}$$

* Example:

- $S_n = 1600$ kVA
- $V_n = 10$ kV

The resulting nominal current is: $I_n = 92.4$ A

Check the table of available CTs in [↔2.6.1.3 Order Form of the WIC1-Compatible Current Transformers](#) or [↔3.3.1.1 Current Ranges of the WIC1-Wx-CTs](#), and you find that both **W3** and **W4** are suitable for this nominal current.

Further criteria can now be applied to pick one out of these suitable CTs.

- Short-circuit transient characteristic:

The WIC1 can measure a short-circuit current of a circuit up to 20 times of the upper rated CT current. (See also the red bars in diagram [↪Fig. 20.](#))

This means for the selected CT:

W3: $112 \text{ A} \times 20 = 2240 \text{ A}$, or

W4: $224 \text{ A} \times 20 = 4480 \text{ A}$.

If the short-circuit current of a circuit is approx. 3 kA, for example, because of the location, then the preference should be given to the **W4**, so that the current can be measured cleanly by the WIC1.

- Operating current:

The operating current should be in the rated CT current range. The WIC1 system can be loaded continuously up to 2.5 times of the upper rated CT current. (See [↪3.3.1.1 Current Ranges of the WIC1-Wx-CTs.](#))

This has no effect on the measurement of the overload. But due to the limitation of the measurement to 20 times the upper rated CT current, the short-circuit protection is limited.

- Accuracy of current measurement:

For low current, the accuracy is better if *»In,relative«* (see [↪12.1.2 Setting of the Rated CT current In](#)) may be set to a higher value, which means a preference for **W3**, especially if low protection thresholds are planned.

For high phase currents, however, and/or if DC offset signals are possible, the accuracy is better if *»In,relative«* is low, which means a preference for **W4**, especially with respect to CT saturation effects and to reliability of [inrush blocking](#).

- Trip times:

Trip times, as measured for an initially switched off WIC1, may be slightly faster for a higher *»In,relative«* because [collecting enough electrical energy](#) for a trip pulse is faster. This is especially true if a DiggiMEC is connected that also drains a little bit of energy. This would be a preference for **W3**.

The calculated nominal current $I_n = 92.4 \text{ A}$ is settable in the WIC1, see [↪12.1.2 Setting of the Rated CT current In](#).

- **W3**: $92.4 \text{ A} = 2.887 \cdot I_{n,\min}$,
- **W4**: $92.4 \text{ A} = 1.443 \cdot I_{n,\min}$.

We listed several criteria in favor of **W3** and **W4** above. Since these depend on the individual preferences of the application it is not possible to give a general rule that meets all aspects. From our experience we can conclude that most real-life applications should select a CT such that *»In,relative«* is within the range $I_{n,\min} \dots 2.5 \cdot I_{n,\min}$. This would prefer the “higher” CT in our example, i. e. **W4**, and the related setting *»In,relative«* = $1.443 \cdot I_{n,\min}$. Of course, this setting value cannot be set exactly with DIP or HEX switches, for these WIC1 variants the best settable value is *»In,relative«* = $1.5 \cdot I_{n,\min}$.

Quick Pick: Look up the CT

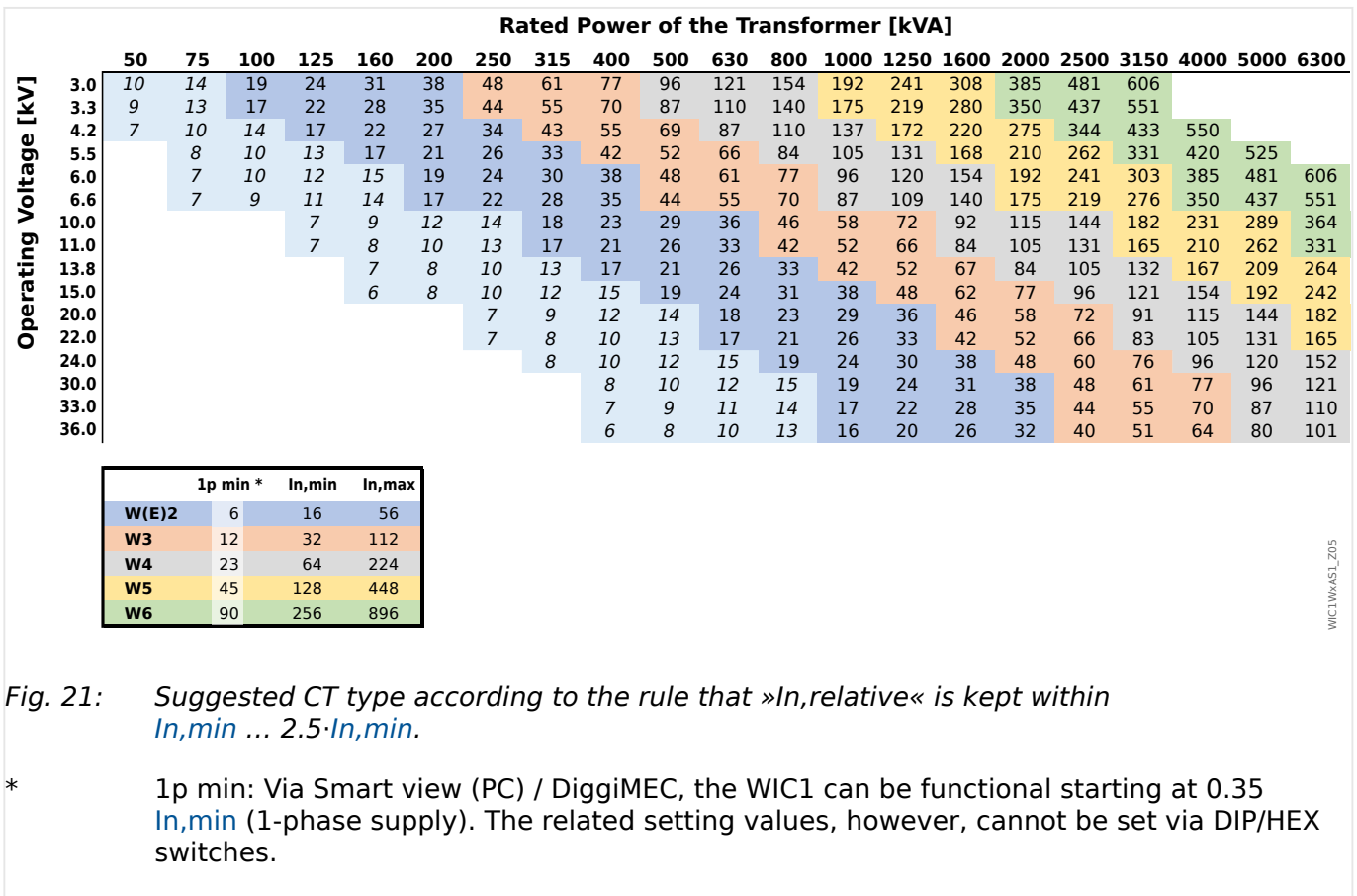

In the diagram above, look up the transformer rating (horizontal axis) and the operating voltage (vertical axis) and find the operating primary current at the related entry. The background color suggests a matching CT.

Example: The transformer data $S_n = 1600$ kVA, $V_n = 10$ kV guides you to the entry "92" [A], and its background color stands for the **W4** CT. (Depending on your application, this might be a simplification, of course. In [↪3.3.1.2 Selection of the CT Transformation Voltage Ratio](#) some of the criteria are listed that can be considered during the planning phase.)

3.3.1.3 CT Type WE2

For small primary currents there is a special "E"-labeled CT available featuring a mixed core based on MU metal with optimized transmission characteristic: WE2.

It is typical of self-powered protection relays such as the WIC1 that small currents cause a non-linear transmission characteristic of the relay. For the W2 CT, which has a low primary current, this effect is typically greater. A lower accuracy can often be accepted for an application without a calculated earth (ground) current protection, making the W2 CT (i.e. without „E“) a cost-effective alternative.

If higher accuracy is necessary, or if a calculated earth (ground) current protection element is required, it is recommended to use the WE2 CT as this CT type is more precise in the lower operating range.

3.3.2 WIC1-WC Converter CTs (1 A / 5 A Measurement)

A direct connection of 1 A / 5 A standard CTs with the WIC1 is not permitted. Nevertheless, a connection of these is possible if the [WIC1-WC Converter CTs](#) are used. These CTs are connected between the secondary side of the standard CTs and the WIC1 phase current inputs. They transform the current to a magnitude that is suitable for the WIC1 protection relay.

Both **WC1** and **WC2** CTs are limited to special order codes of the WIC1. Please make sure you have the correct combination of relay type and WC CT. Please refer to [↔2.6.1 Order Forms](#) for more information.

WARNING!



Due to technical constraints with respect to construction, the Converter CT has a window, just like the feed-through of a standard CT. But it is not permitted to mount an MV / primary current cable through this Converter CT window!

Ignoring this can result in dangerous voltages at the contacts, and due to wrong measuring values there would not be any effective protection of your equipment.

NOTICE!



Please note also these peculiarity, that are inherent to the construction of the Converter CTs:

- The housing (see [↔Fig. 18](#)) contains three Converter CTs, so that all three phase currents are covered. Therefore you need to buy only one unit, see also [↔“WIC1-WC Converter CTs for 1 A or 5 A”](#).
- There are no test windings. Therefore the test sockets of the WIC1 **cannot** be used with the Converter CTs.

Settings

See also the notes under [↔“Settings - CT & Rated Current”](#).

The rated current can be configured as a primary value in A:

- [Field Para / CT] . »CT Type« = “WC2^(*)” or “WC1”
- [Field Para / CT] . »CT pri«

(*) This is already pre-configured for compatible [WIC1 Order Codes](#) and works out of the box.

If the relative setting as a multiple of [In,min](#) is used:

- **WC1**-CT: »CT . In,relative« = 1.0
- **WC2**-CT: This is already pre-configured for compatible [WIC1 Order Codes](#) and works out of the box. The parameter »CT . In,relative« should not be used in this case and is therefore inactive.

Connection Diagrams

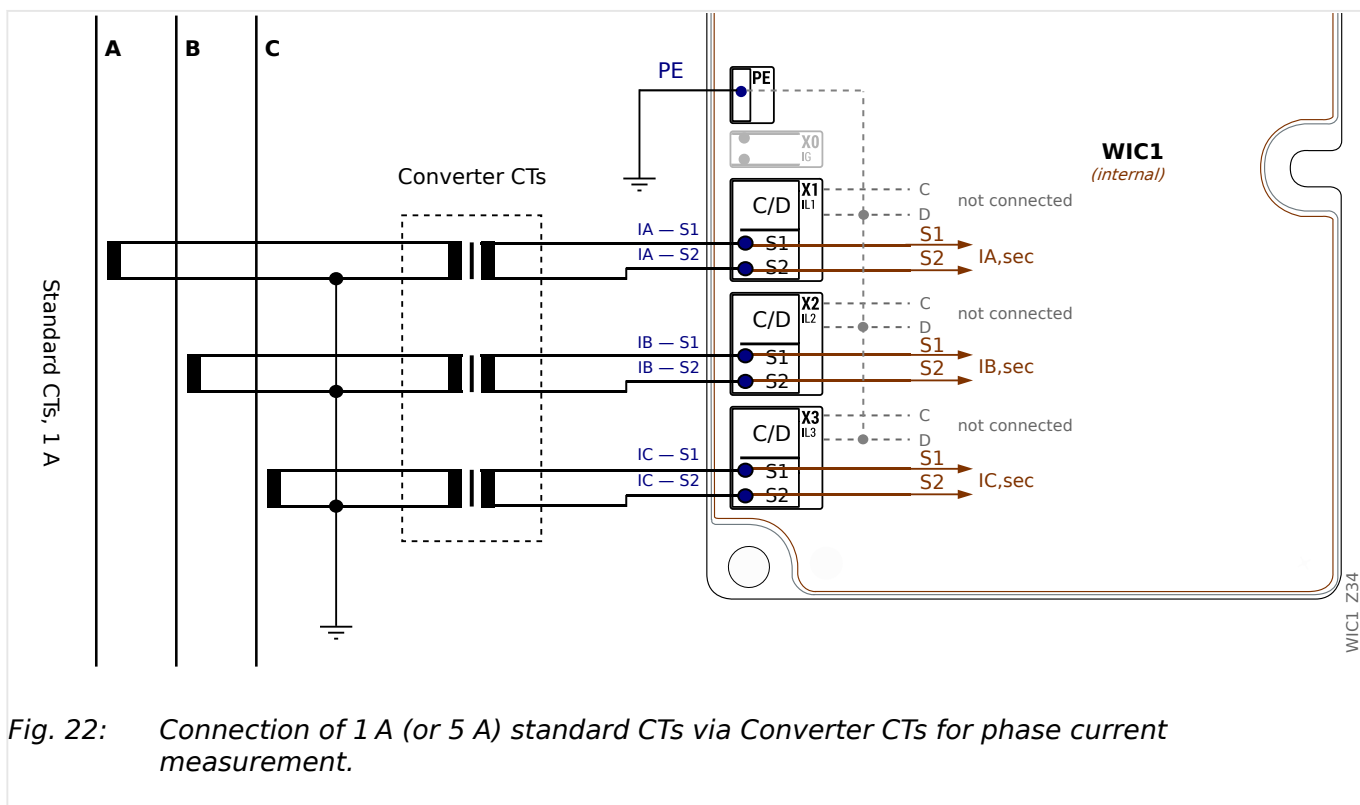

Fig. 22: Connection of 1 A (or 5 A) standard CTs via Converter CTs for phase current measurement.

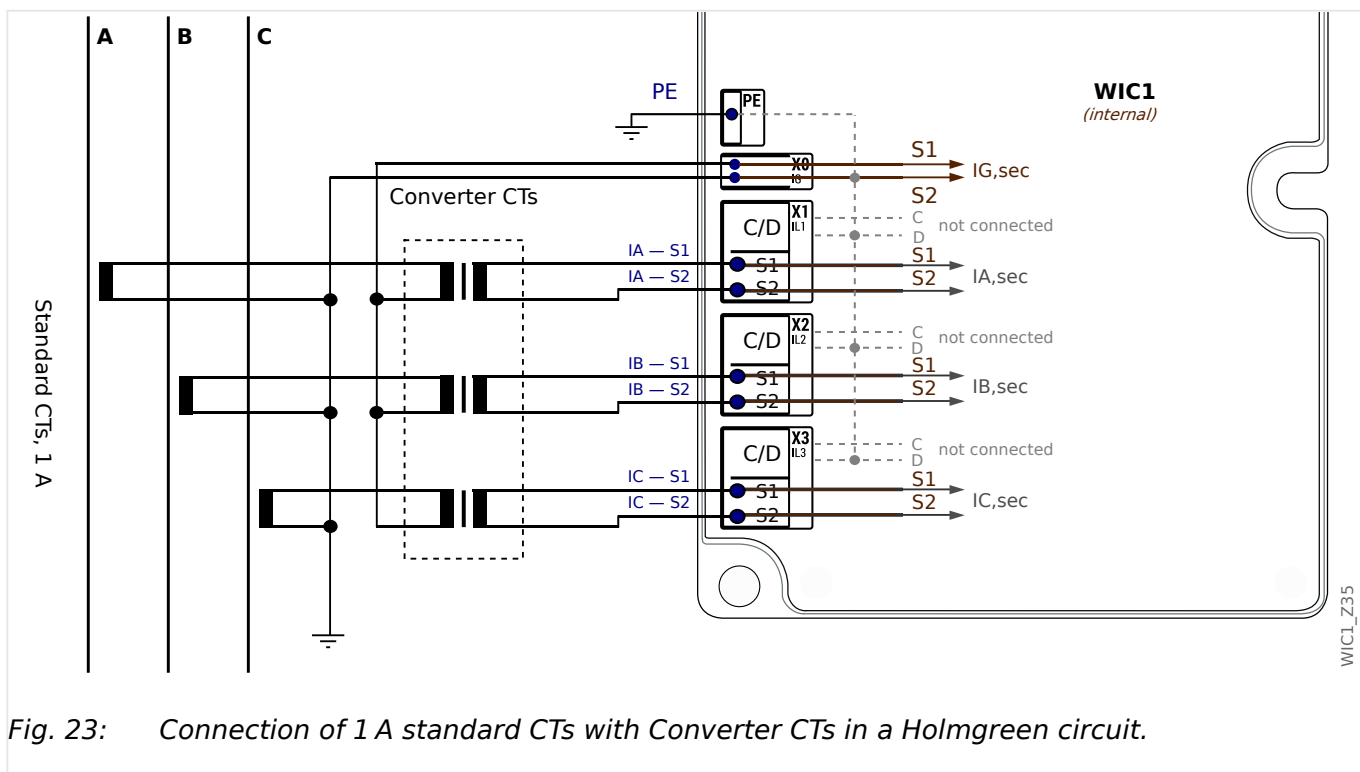



Fig. 23: Connection of 1 A standard CTs with Converter CTs in a Holmgreen circuit.

WARNING!



Since the WIC1 has only a 1 A ground current input, the Holmgreen circuit is not available with 5 A CTs.

NOTICE!	
	In earlier revisions of this manual before R2.3, the wiring of IG at terminals X0.S1 & X0.S2 was incorrectly shown as reversed in →Fig. 23. Correctly, S2 must be connected to the grounded secondary side of the standard CTs (= primary side of the Converter CTs), because S2 is also internally connected to ground within the WIC1. Otherwise, the ground current measurement inputs would be bypassed resulting in reduced sensitivity of the Earth (Ground) Overcurrent Protection.

3.3.2.1 Requirements for Standard CTs

The Standard CTs must fulfill specific requirements to be used in combination with the Converter CTs. The following data, however, is very simplified. If it does not suit your application, there is a more detailed version under →12.3 Requirements for 1 A/5 A Standard CTs with WIC1-WC Converter CTs.

The burden power rating (in VA) of the standard CT has to be multiplied with its Accuracy Limit Factor (ALF). The result has to be above a particular threshold:

	Minimum requirement	Max. additional resistances*1)	Max. additional resistances*1) (Holmgreen connection)
WC1-1A	$ALF \cdot S_{VA} \geq 10VA$	0.2 Ω	0.1 Ω
WC1-5A	$ALF \cdot S_{VA} \geq 200VA$	0.2 Ω	Holmgreen not possible*2)
WC2-1A	$ALF \cdot S_{VA} \geq 30VA$	0.2 Ω	0.1 Ω

*1) Maximum permissible value of additional resistances in the **secondary circuit of the Standard CT** (e.g. additional cables, short circuit rails, etc.).

*2) Holmgreen is not possible with 5 A Standard CTs because the WIC1 does not have a 5 A ground current input.

Example Calculation

Standard CT, 1 A	5P5 2.5 VA
Converter CT	WIC1-WC1-1A

Use the formula from above for the WC1-1A CT to calculate the product of burden rating and ALF:

$$ALF \cdot S_{VA} = 5 \cdot 2.5 VA = 12.5 VA \geq 10VA$$

The calculated value is higher than the minimum requirement of 10 VA. Therefore the CT is sufficient for the given application.

CAUTION!

The maximum permitted short-circuit current of the Converter CTs is $100 \cdot I_r$ for the duration of 1 second. (See also [↔10.5.4 Technical Data - WIC1-WC Converter CTs for 1 A, 5 A](#))

3.4 Phase and Ground Current Measuring Inputs

The WIC1 is provided with current measuring inputs for measuring the phase currents and – for the appropriate variants – one for measuring the earth (ground) current:

- WIC1-x**S**: 3 phase current inputs.

The phase current inputs are designed for the WIC1-compatible CTs, see [↔2.6.1.3 Order Form of the WIC1-Compatible Current Transformers](#).

- WIC1-x**SN**: No ground current measurement. The ground current must therefore be calculated out of the phase currents.
- WIC1-x**SG**: 1 ground current measuring input, that is designed for a CT with secondary current of 1 A.

In addition, there are test inputs available for phase currents and ground current, as dedicated terminals and (internally connected) sockets at the front side of the device. (See diagrams [↔Fig. 24](#), [↔Fig. 25](#).) These test inputs can be used for secondary tests during commissioning. (See [↔8.1.4.2 Wiring Checks](#).)

DANGER!



The terminal block for connection to the current transformers is not a shorting block. Therefore always short-circuit current transformers before loosening the terminals.

Ignoring this can result in dangerous voltages at the open contacts (up to dozens of kilovolts depending on the CT type).

CAUTION!



Only the special WIC1-compatible CTs are permitted for the phase current inputs! The connection of common CTs with secondary currents of 1 A or 5 A is not permitted for the phase current inputs! (An exception is the use of a special Converter CT, see [↔3.3.2 WIC1-WC Converter CTs \(1 A / 5 A Measurement\)](#).)

The ground current input – if available – is designed for a CT with secondary current of 1 A.

The properties of the Current Transformers, in particular the rated CT current I_n , must also be specified in the settings, see [↔12.1.2 Setting of the Rated CT current \$I_n\$](#) .

The input for earth (ground) current measuring – if available – can be connected to a cable-type current transformer.

The test inputs are convenient for the secondary tests during commissioning: A test current can be fed into the WIC1, without the need to disconnect the cables from the current measuring inputs. See [↔8.1.4.2 Wiring Checks](#).

DANGER!



The WIC1 must be grounded/earthed at the correct terminal “PE”, see also [↔3.1.2 Grounding](#).

CAUTION!

The measuring winding (terminals S1 and S2, and - if available - S3, S4) of the CTs must not be earthed, otherwise the measurement results are distorted, ensuring in erratic behavior of the WIC1.

DANGER!

The current measuring inputs may exclusively be connected to current measuring transformers (with galvanic separation) of the type matching the ordered WIC1 variant.

DANGER!

The terminal block for connection to the current transformers is not a shorting block. Therefore always short-circuit current transformers before loosening the terminals.

Ignoring this can result in dangerous voltages at the open contacts (up to dozens of kilovolts depending on the CT type).

DANGER!

The WIC1-compatible current transformers are dimensioned for nominal voltages < 1000 V. This means for an application in MV-switchboards (i. e. voltages < 36 kV) that these current transformers may only be used with insulated primary conductors, for example cables, with appropriate insulation resistance against earth. These current transformers are not allowed to be used for non-insulated primary conductors > 1000 V against ground (earth).

In addition, the medium voltage cables, whose phase currents shall be measured via the CTs, must be furnished with a grounded/earthed shielding.

Ignoring this can result in dangerous voltages at the open contacts (up to dozens of kilovolts depending on the CT type).

3.4.1 Current Measuring Inputs for WIC1-CTs and Without Ground Current Input

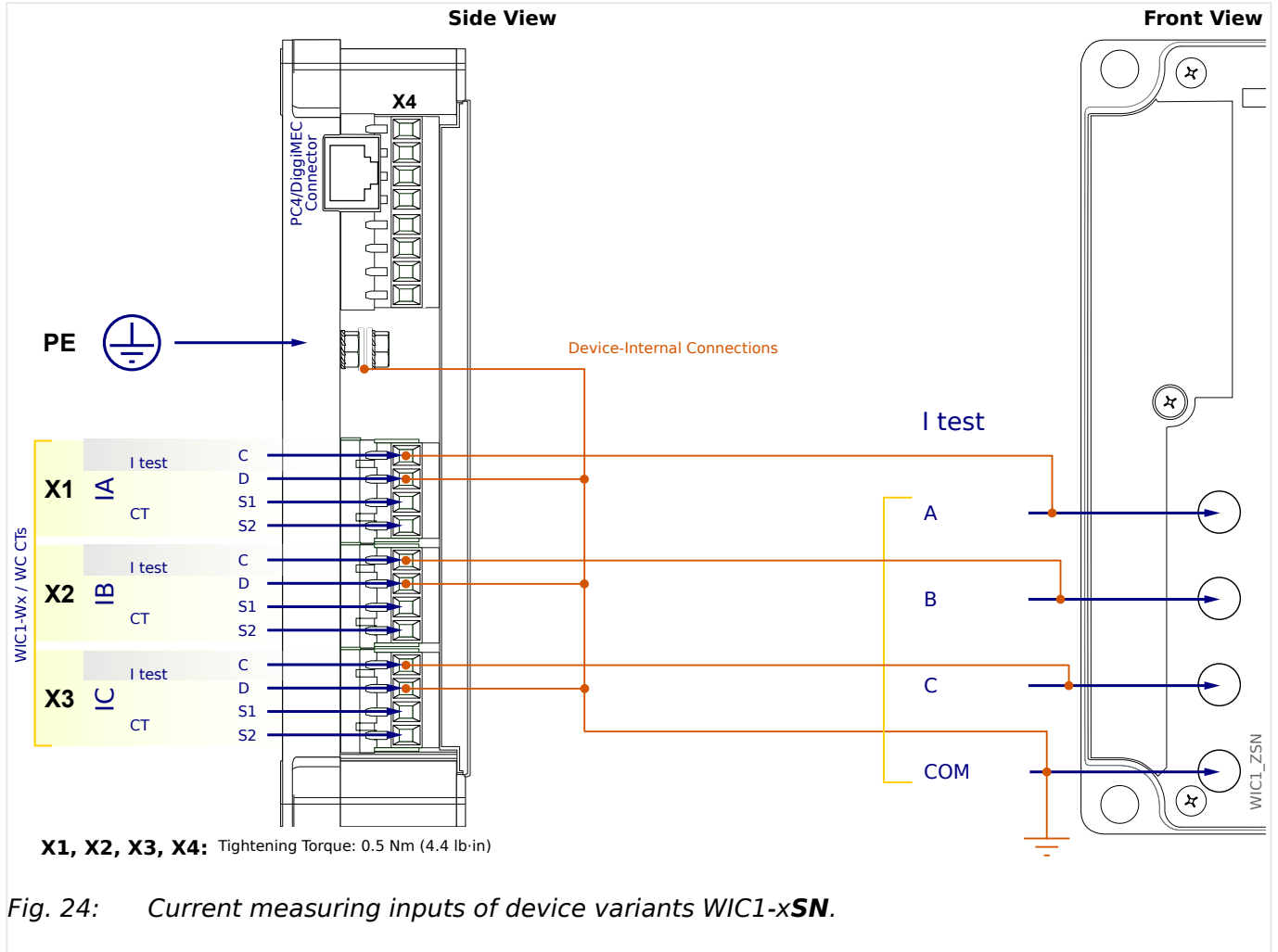

3.4.2 Current Measuring Inputs for WIC1-CTs With Ground Current Input

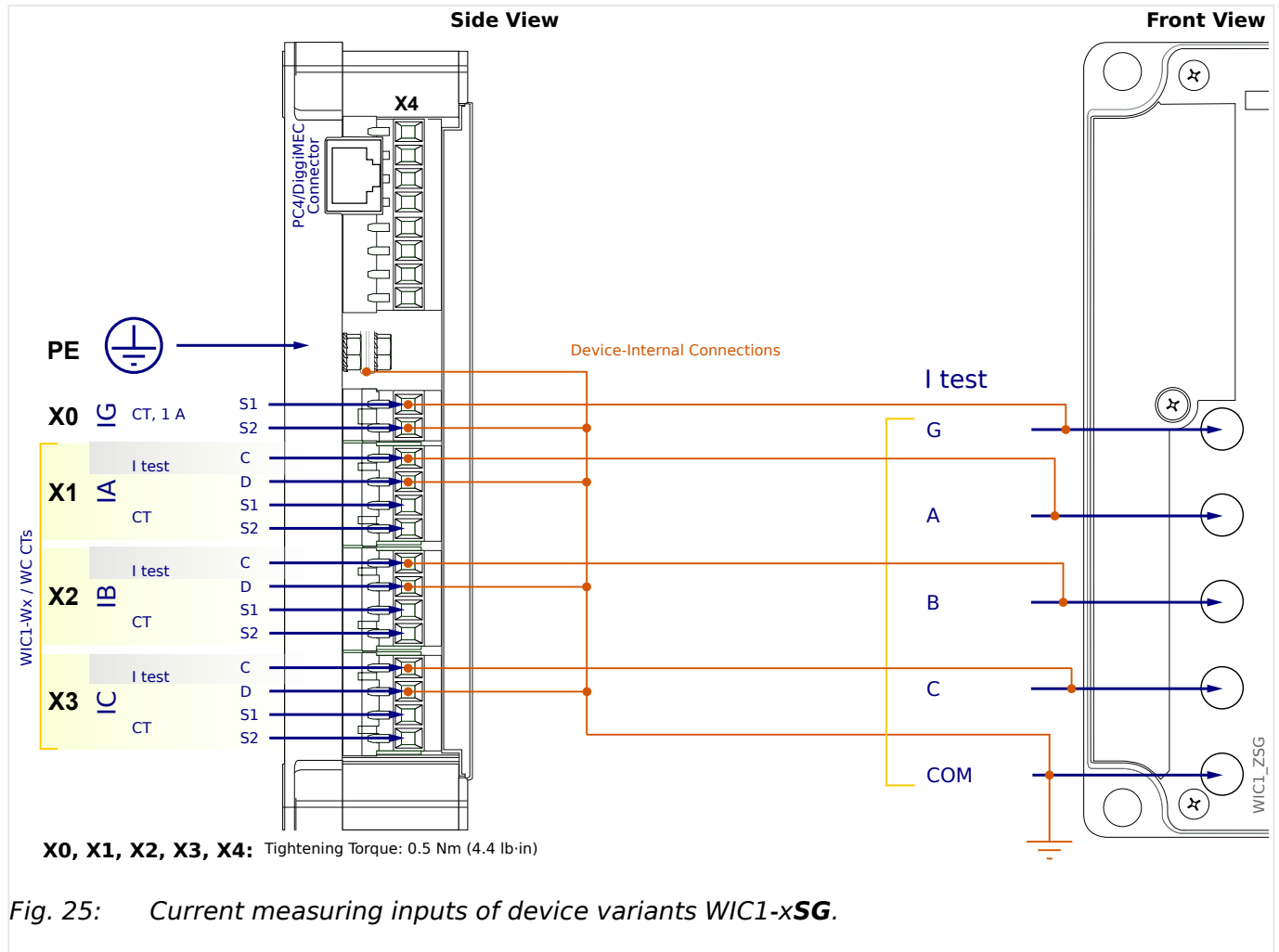

3.5 Digital Input (only WIC1-1... / WIC1-2... / WIC1-3...)

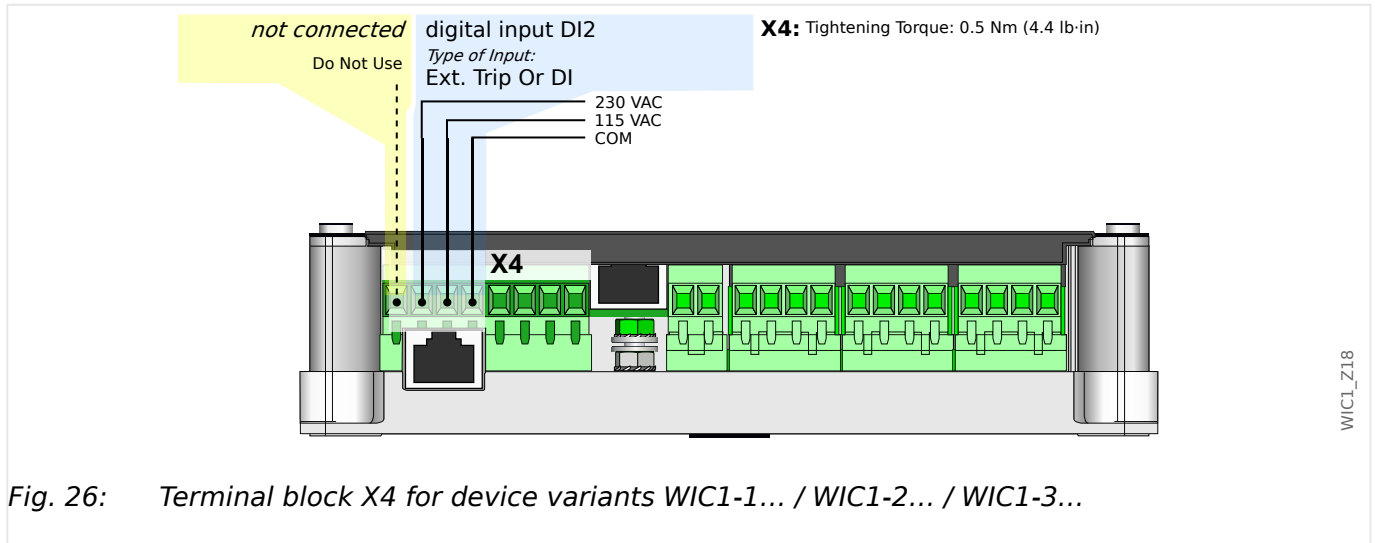

Fig. 26: Terminal block X4 for device variants WIC1-1... / WIC1-2... / WIC1-3...

The “Inputs” terminal block (see also [↔3.1 Overview of Elements and Connectors](#)) **always** features:

- a “COM” common terminal, that serves as the common potential for all other inputs.

Moreover, this terminal block can feature (depending on the [order options](#)) a digital input based on 115 VAC or 230 VAC input signals. (See [↔10.1.9 Remote \(External\) Trip Input / Digital Input \(WIC1-1, WIC1-2, WIC1-3\)](#) for details.)

This digital input is always referred to as **DI2**, when it comes to settings or displaying states. (Note that nonetheless, these device variants do not have a DI1.)

- For device variants WIC1-#xxxxx**F**xxxx, this input has a fixed function as an external trip signal.

An external trip signal triggers the protection function »ExP«, see [↔5.12 ExP – External Protection](#). Depending on its configuration, »ExP« issues either an alarm message or trips the circuit breaker (via the impulse output, [↔“Impulse Output for a Trip Coil”](#)).

- For device variants WIC1-#xxxxx**C**xxxx, this input is configurable.

If the input is used for an external trip together with a cold restart of the WIC1 the resulting tripping time depends on the input voltage. This is due to the recharging time of the capacitors for the trip signal. However, as long as the voltage is within the [specified range](#), the tripping time is ≤ 0.5 s. (See also [↔10.2.1.8 External Protection](#).)

CAUTION!



It is not allowed to connect any continuous voltage to the 115 VAC or 230 VAC input!
Any continuous voltage can destroy the internal signal transformer.

3.6 Additional Power Supply and Digital Inputs (WIC1-4... only)

CAUTION!



The Digital Inputs of the WIC1-4 are **not potential-free** with each other, but always related to the “COM” terminal (see diagrams). The voltages used at the Digital Inputs and the Dual Power Input must have the same nominal voltage. **AC voltages at the Digital Inputs must also be 110 VAC or higher.**

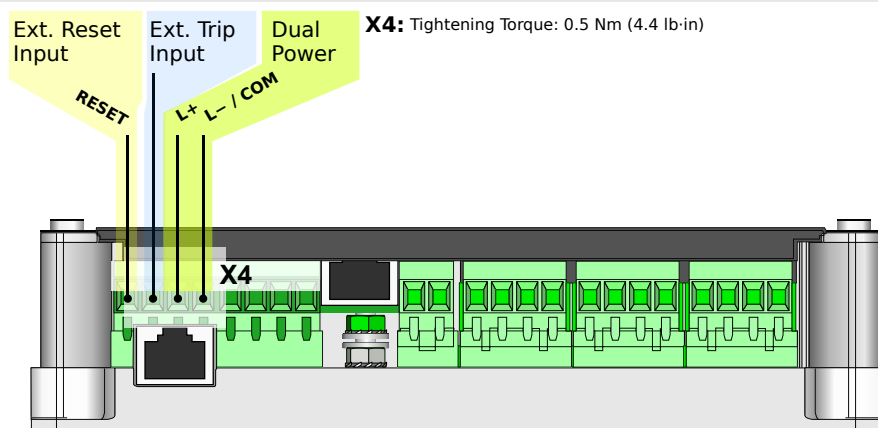

Fig. 27: Terminal block X4 in case of the “External trip+reset input” order option.

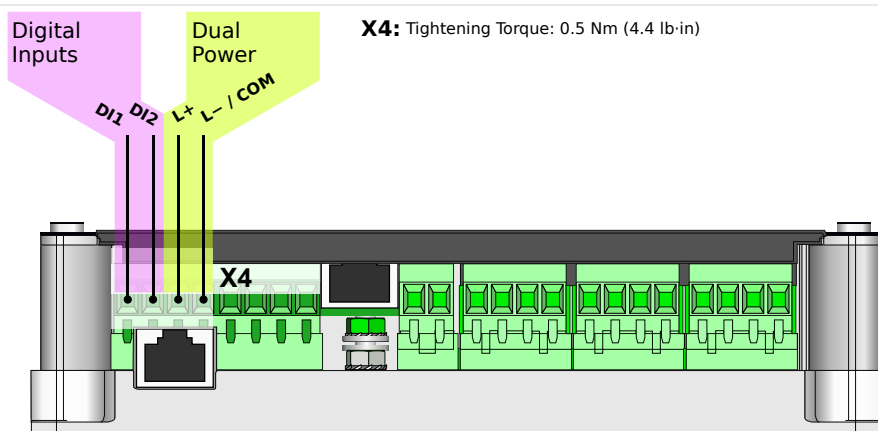

Fig. 28: Terminal block X4 in case of the order option “two configurable Digital Inputs”.

Terminal block X4 (see also ↪3.1 Overview of Elements and Connectors) **always** features:

- a “COM” common terminal, that serves as the common potential for all other inputs.

Moreover, this terminal block can feature the following, depending on the ordered device variant:

- Inputs for an additional auxiliary power supply unit.
- 2 (grouped) digital inputs. These can be as follows, depending on the ordered device variant:
 - Inputs for external trip signal and external reset signal (non-configurable inputs).

- 2 configurable digital inputs.

(For the order options of the WIC1, see [↔2.6.1 Order Forms](#).)

Additional Power Supply

The WIC1 does not require any aux. voltage supply, consequently it can also be used for switchboards without auxiliary power supply. It takes its power supply energy from the CT circuits and provides the tripping pulse energy to the circuit breaker.

However, the WIC1-4 variant with the “Dual Power” order option allows for connecting an additional external power supply.

The dual power source makes the relay independent of the supply via the CTs, so that it can also operate in case of very small phase currents or after a protection trip. The dual-power will make the relay n-1 secure, because the electrical power that the relay requires for operation is taken either from the dual power source or from the CTs.

The permissible voltages for the optional auxiliary supply can be found in [↔10.1 Technical Data - WIC1](#).

Digital Inputs

The WIC1-4 is provided with 2 grouped digital inputs.

For some device variants, the assignment of the digital inputs is fixed to “external reset” and “external trip”. For the other device variants, the assignment is set to “external reset” and “external trip” by default, but can be changed.

- „External trip“ — By default, an external trip signal triggers the protection function »Exp[1]«, see [↔5.12 ExP - External Protection](#). Depending on its configuration, »Exp[x]« issues either an alarm message or trips the circuit breaker (via the impulse output, [↔“Impulse Output for a Trip Coil”](#)).
- „External reset“ — An external input signal resets several latched states, see the table in [↔2.11 Reset](#).

Independent of the device variant, it is necessary to set the nominal input voltage for the Digital Input(s):

- [Device Para / WIC1 / Digital Inputs] »Nom voltage« — The available select options depend on the device variant.

Note that some debouncing is performed for each digital input based on a fixed, device-internal algorithm.

In case of insufficient power supply, the WIC1-4 is powered via the digital inputs as long as they are active.

Please also note the information related to the technical data under [↔10.1.10 Digital Inputs \(WIC1-4\)](#)!

3.7 Serial Interface RS485 (WIC1-4... only)

WARNING!



Ensure the correct tightening torques.

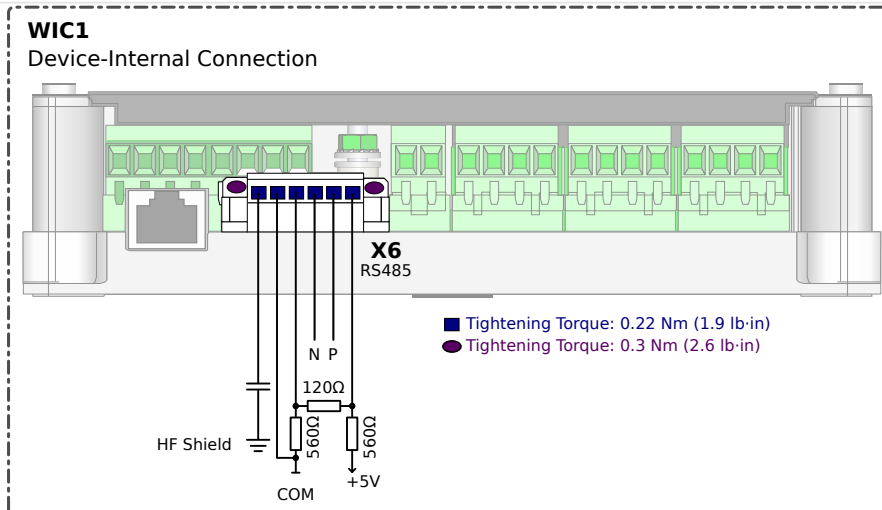

Fig. 29: RS485 Terminals / Electro-mechanical assignment.

A serial RS485 interface may be available depending on the [ordered device type](#).

It can be used for the [Modbus RTU](#) SCADA protocol.

NOTICE!



The RS485 interface is usable only if the WIC1-4 is supplied with an auxiliary voltage. It is switched off in self-supplied operating mode.

The Modbus[®] connection cable must be shielded. The shielding has to be fixed at the PE screw.

The communication is halfduplex.

3 Hardware

3.7 Serial Interface RS485 (WIC1-4... only)

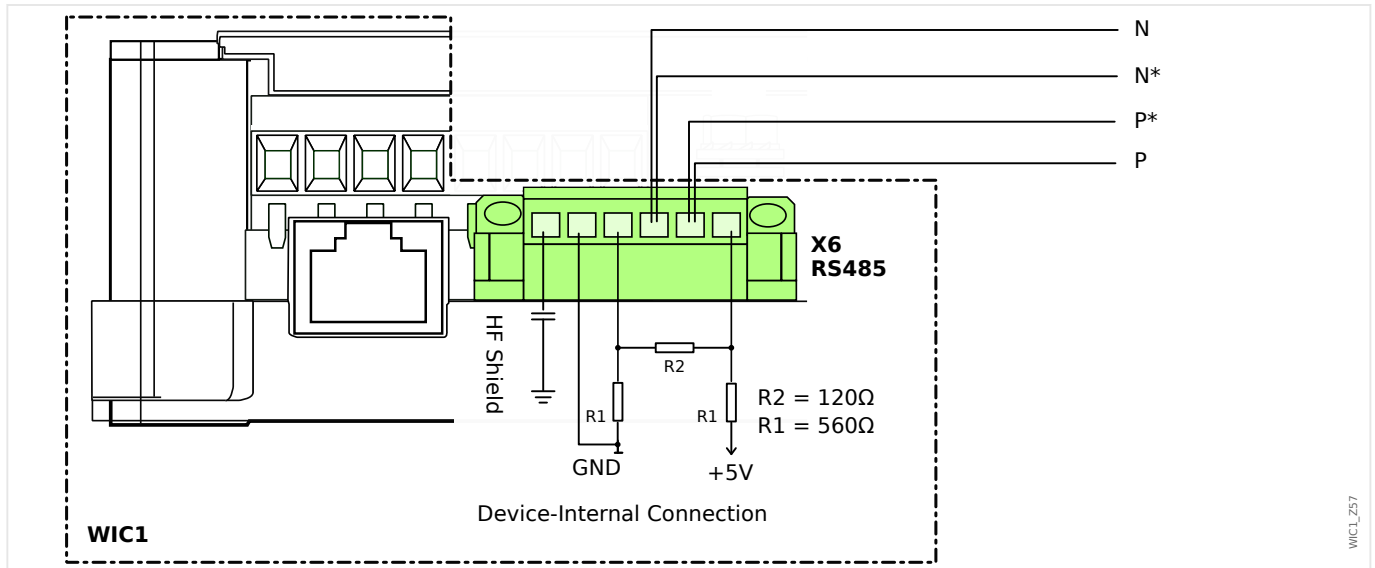

Fig. 30: Wiring example, Device in the middle of the bus.

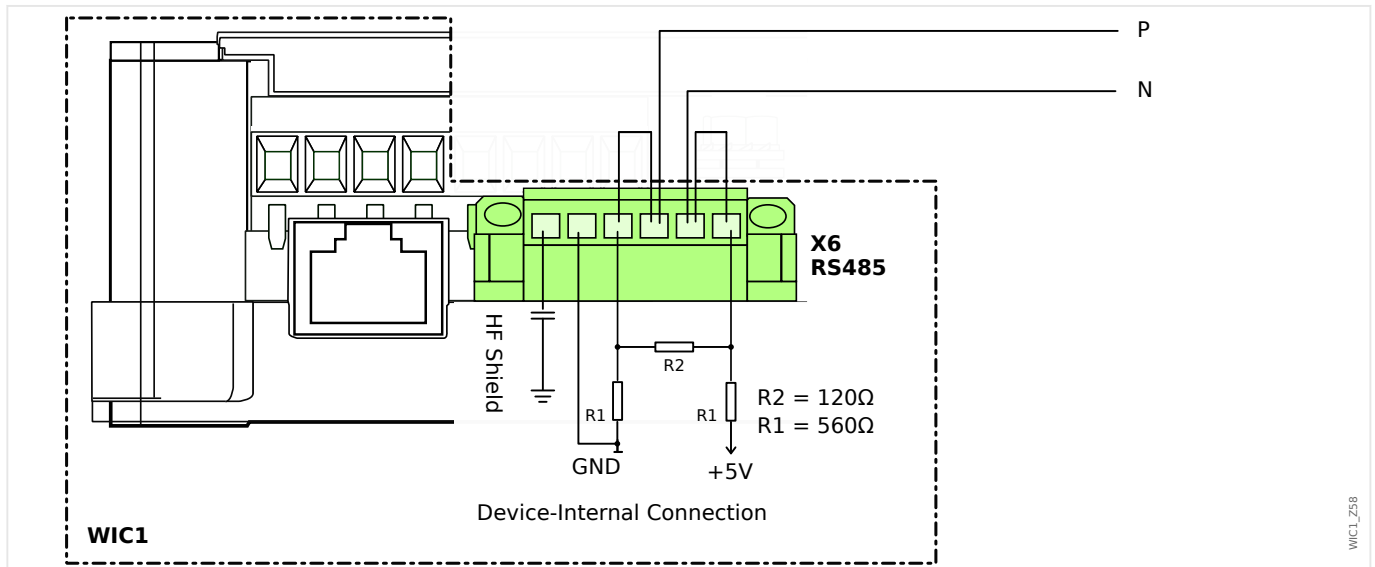
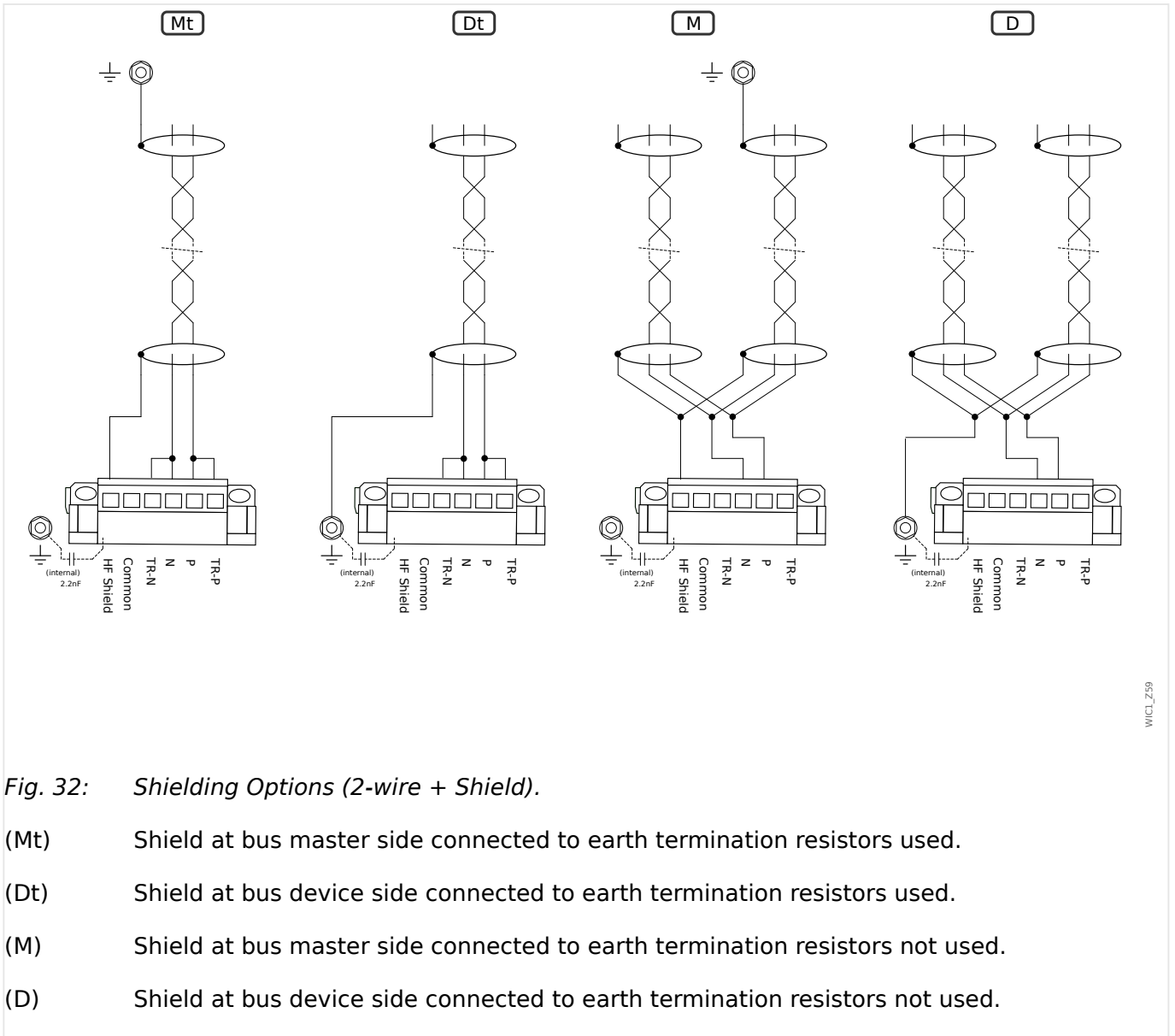

Fig. 31: Wiring example, Device at the end of the bus. (Activation of the integrated Terminal Resistor.)



WIC1_59

3 Hardware

3.7 Serial Interface RS485 (WIC1-4... only)

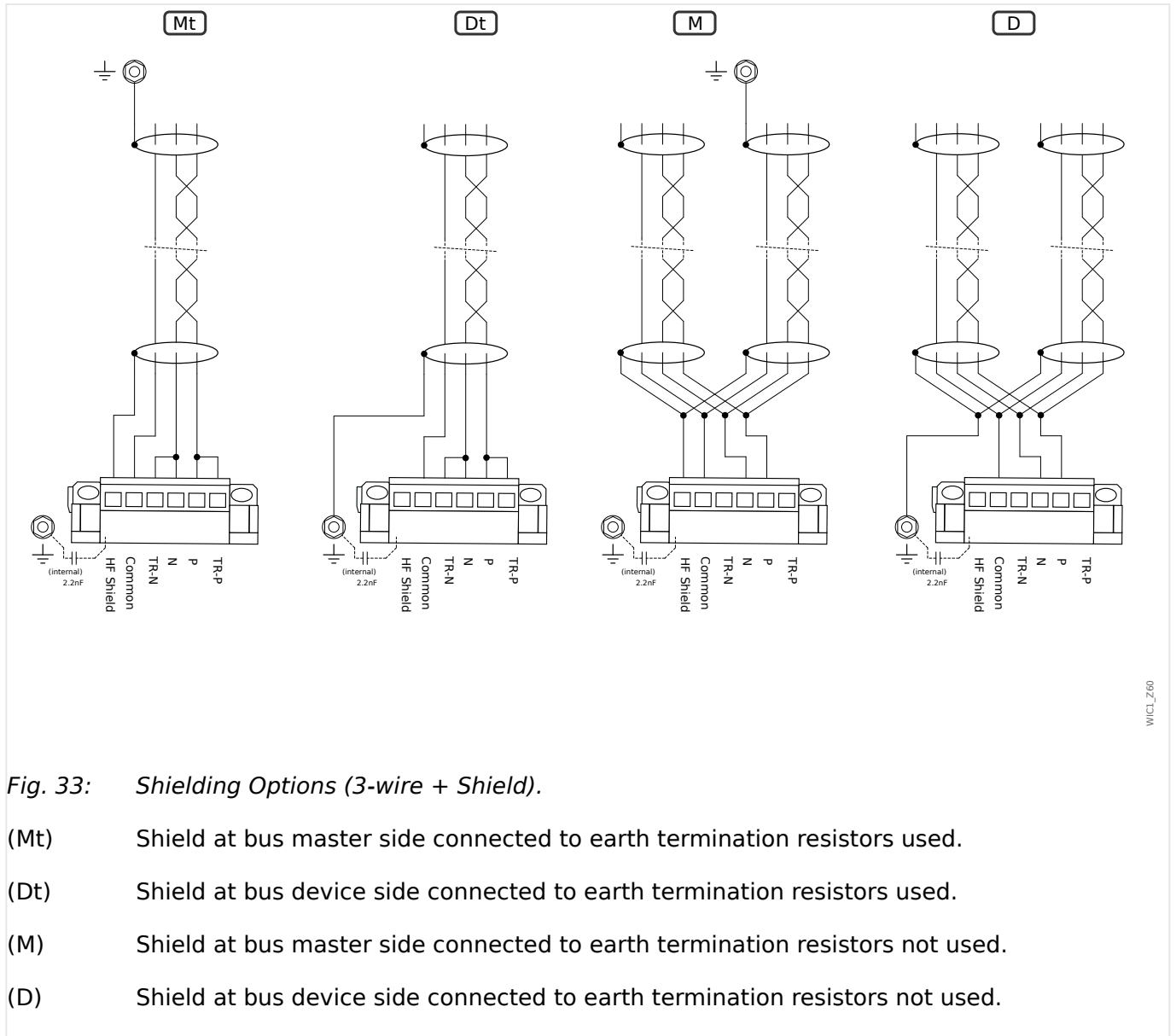

WIC1_60

3.8 Ethernet Interface (RJ45)

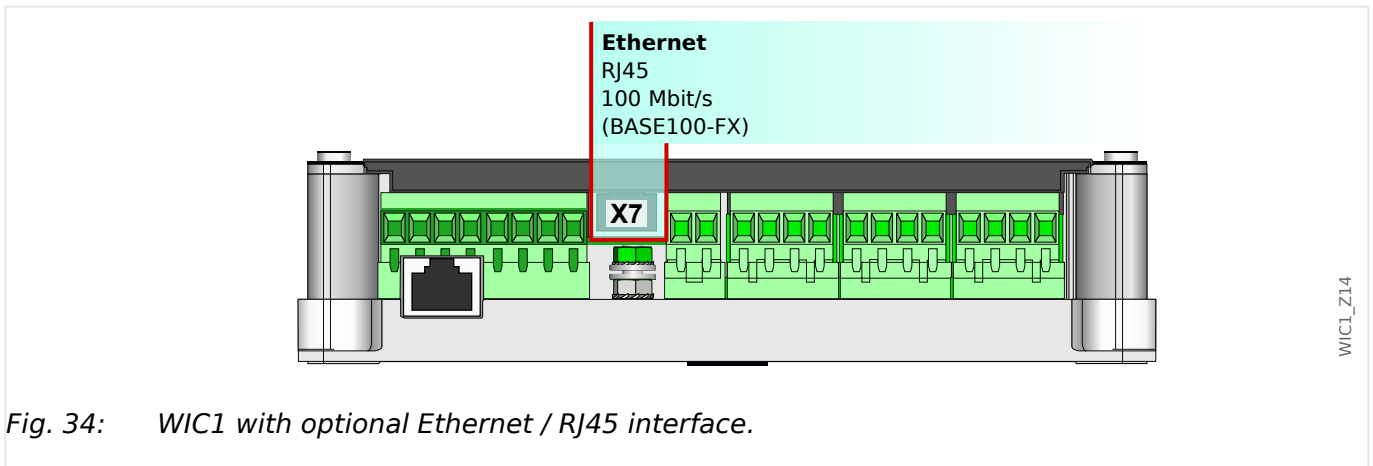

Fig. 34: WIC1 with optional Ethernet / RJ45 interface.

An Ethernet interface may be available depending on the [ordered device type](#).

It can be used for the following SCADA protocols:

- [Modbus TCP](#)

Caution: RJ45 cables with an excessively large latching lug protection (grey plastic part in the picture on the right) cannot be installed when using the WIC1 plastic cover for the side terminals. Therefore, it is recommended to use RJ45 cables without latching lug protection for the X7 interface.

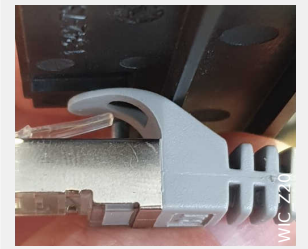

NOTICE!



Ethernet-related software modules, in particular »TCP/IP« and »Modbus TCP«, are carried out by a co-processor, i. e. a second CPU. This unburdens the main CPU and thus stabilizes all protection functionality. Even in the extreme case that the TCP/IP communication should crash, would all protection modules continue with full functionality.

For the Modbus TCP communication, however, this recommends that the user keeps in mind the times described in →[“Cycle Times with Modbus TCP and RTU”](#).

3.9 Ethernet / TCP/IP via Fiber Optics

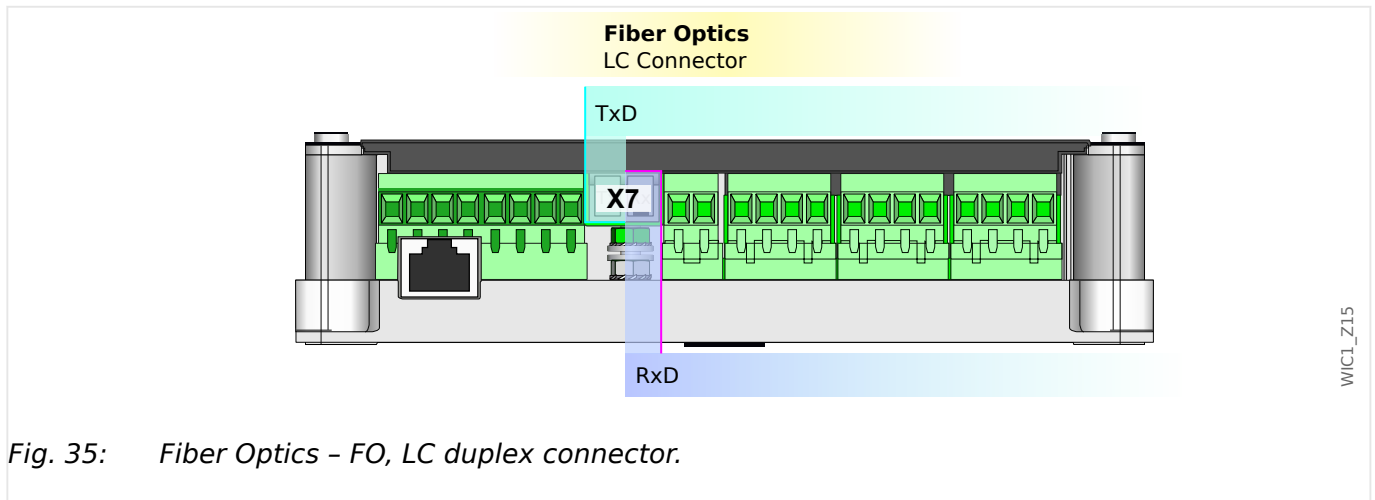

Fig. 35: Fiber Optics – FO, LC duplex connector.

WARNING!



Do not look directly into the light beam that is emitted from the fiber optics connector!
Serious injury of the eyes can be consequence of ignoring this warning.

A fiber optics interface with LC duplex connector may be available depending on the [ordered device type](#).

It can be used for the following SCADA protocols:

- [Modbus TCP](#)

NOTICE!



Ethernet-related software modules, in particular »TCP/IP« and »Modbus TCP«, are carried out by a co-processor, i. e. a second CPU. This unburdens the main CPU and thus stabilizes all protection functionality. Even in the extreme case that the TCP/IP communication should crash, would all protection modules continue with full functionality.

For the Modbus TCP communication, however, this recommends that the user keeps in mind the times described in ↪[“Cycle Times with Modbus TCP and RTU”](#).

3.10 Outputs (Trip Coil, Flag Indicator, Relay Output)

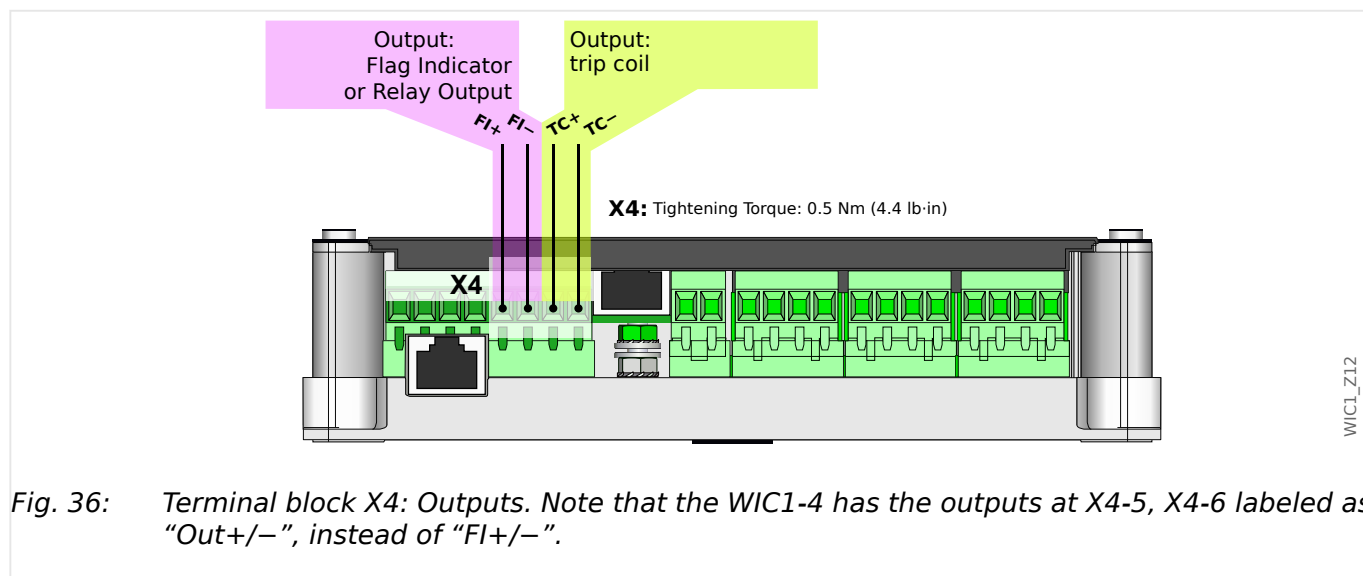

Terminal block X4 (see also [↔3.1 Overview of Elements and Connectors](#)) **always** features:

- a pulse output for a low-energy trip coil.

Furthermore, it **can** feature (depending on the [order options](#)):

- an output, that operates as a pulse output for a mechanical flag indicator, see [↔"Impulse Output for a Flag Indicator \(all WIC1 variants\)"](#).

For an externally supplied WIC1-4, this output can also function as a relay output, see [↔"Relay Output \(WIC1-4\)"](#).

CAUTION!



It is not allowed to connect any active voltage to the trip coil output or to the output (flag indicator / relay output).

CAUTION!



For a WIC1-4, it is also necessary that the configured operating mode matches the connected hardware!

(For example, it is not permissible to connect a flag indicator and set the operating mode to "Syst. O.K. & Ext.Suppl.". See also the related Self-Supervision warnings [SW 3](#), [SW 4](#).)

Moreover, the electrical energy that an output relay drains with operating mode "Syst. O.K. & Ext.Suppl." requires that the WIC1-4 is supplied by an external auxiliary voltage.

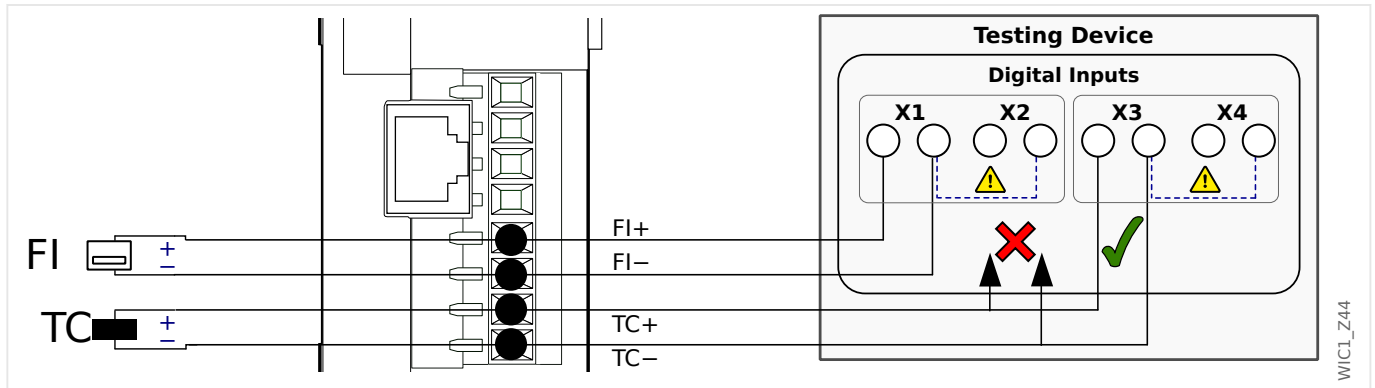

Fig. 37: **Note:** The two outputs may be connected at the same time to test equipment (e. g. to binary inputs of an Omicron[®] device) only if these two binary inputs do **not** share a common potential. Otherwise this external potential bridge, together with device-internal circuits, can produce incorrect test results.

Impulse Output for a Trip Coil

The low-energy trip coil of the circuit breaker is connected to terminals TC+ and TC- of the terminal block X4. The trip energy is provided by a capacitor store integrated in the protection relay. See also →5.1.1.1 Trip Pulse and WIC1 LEDs.

Length of each trip impulse:	(approx.) 50 ms The pause between the individual pulses depends on the impedance of the tripping coil and the current level. Pulsing is continued until the protection function’s tripping state drops off.
Trip energy:	$E \geq 0.1 \text{ Ws}$
Voltage:	24 VDC nominal voltage

Relay Output (WIC1-4)

With the device variant WIC1-4, it is possible via setting parameter [Device Para / WIC1 / Output] »Prot. Out. Mode« to select between two operating modes for the output “Out+/-”:

- = “Impulse Output” — The contacts “Out+/-” function as an impulse output for a flag indicator. This operating mode is fully compatible to the “FI+/-” impulse output of the first generation WIC1, see also →“Impulse Output for a Flag Indicator (all WIC1 variants)”.
- = “Syst. O.K. & Ext.Suppl.” — The contacts “Out+/-” output a digital signal, so that an external output relay (of a particular type, see →10.1.8.3 Relay Output (WIC1-4)) can be connected.

The main application for this output relay is its use as a self-supervision contact. For details, see →3.10.1 Self-Supervision Contact for the WIC1-4.

Remark: The “Syst. O.K. & Ext.Suppl.” operating mode is also available with the “no-output-variants” WIC1-4xxxxNxxxxx. However, for the device variants WIC1-1, WIC1-2, WIC1-3 the operating mode “Impulse Output” is fixed, so that the output can only be used for triggering a flag indicator.

Impulse Output for a Flag Indicator (all WIC1 variants)

Depending on the [order option](#), the WIC1 can feature an impulse output for a flag indicator.

A flag indicator can be connected to terminals FI+/- (WIC1-4: Out+/-) of the terminal block X4, e. g. for a power-safe signaling of a trip. See also [↪3.10.3 Impulse Signal for the Flag Indicator](#).

Length of each trip impulse:	(approx.) 50 ms The pause between the individual pulses depends on the impedance of the flag indicator and the current level. Pulsing is continued until the protection function's tripping state drops off.
Energy:	≥ 0.01 Ws
Voltage:	24 VDC nominal voltage

A mechanical flag indicator **WI1-SZ4** or **WI1-SZ5** can visualize a signal, for example a trip signal, in a power-outage-safe manner. (In case of the [WI1-SZ5](#) this can be done potentially free via two changeover contacts.)

Remark: Availability and configuration options of the Flag Indicator "FI" output depend on the device variant. Please refer to [↪2.6.1 Order Forms](#) for more information.

More information on the flag indicators **WI1-SZ4**, **WI1-SZ5**:

- Connection diagrams: [↪3.10.2 Connecting a Flag Indicator to the WIC1](#)
- Dimension diagrams: [↪3.2.4 Dimension Drawing of the Flag Indicators WI1SZ4, WI1SZ5](#)
- Impulse signal: [↪3.10.3 Impulse Signal for the Flag Indicator](#)
- Technical Data: [↪10.6 Technical Data - WI1SZ4](#), [↪10.7 Technical Data - WI1SZ5](#)

3.10.1 Self-Supervision Contact for the WIC1-4

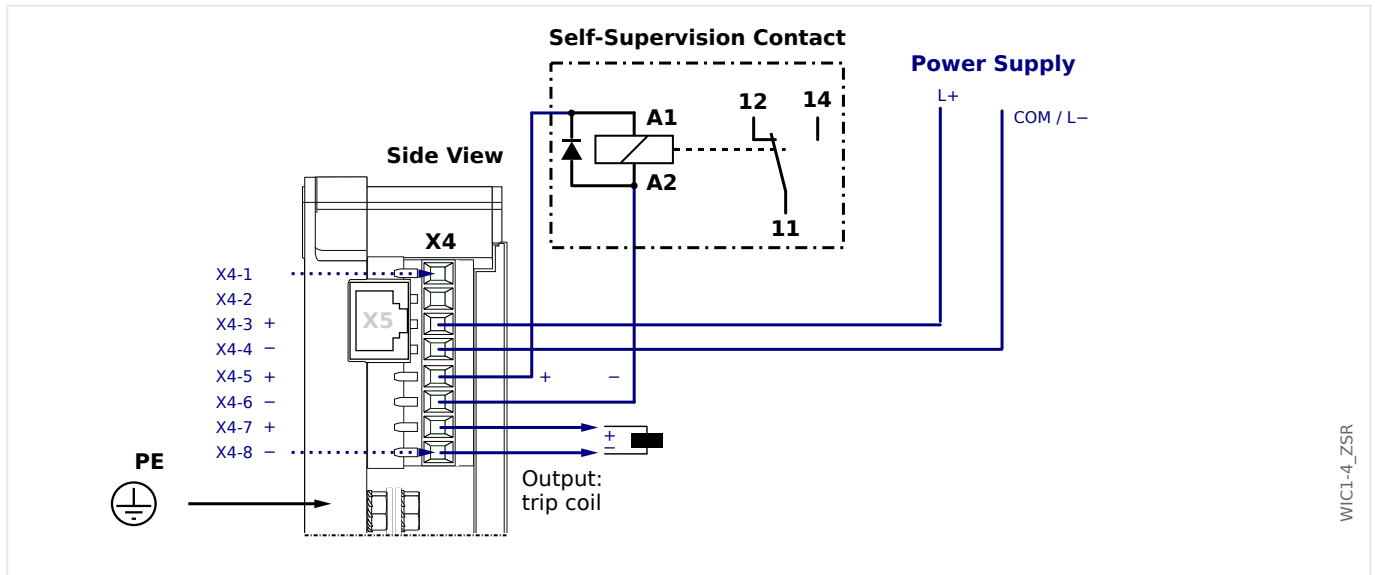

Fig. 38: Connecting an external self-supervision contact.

An externally supplied WIC1-4 allows for connecting an output relay that operates as a “Healthy” / self-supervision contact. (See [diagram](#).)

The contact is kept closed as long as the WIC1-4 is externally supplied **and** healthy (i. e. the [Self-Supervision](#) does not detect a problem). This means the contact is opened in case of a device-internal fault or if the external power supply drops off. (However, all protection functions remain fully active, based on the self-supply of the WIC1, if the external supply stops without a device-internal fault.)

⚙️

1. ▷
2. ▷

The output relay must fulfill the specifications in [↔10.1.8.3 Relay Output \(WIC1-4\)](#).

The operating mode of the “Out+/-” output must be set via software parameter as follows:

- [Device Para / WIC1 / Output] »Prot . Out. Mode« = “Syst. O.K. & Ext.Suppl.”

(There is a special device-internal “Healthy” signal, that is used particularly for this purpose, see also the diagram [↔Fig. 50](#) in [↔5.1.1.1 Trip Pulse and WIC1 LEDs](#). With the setting above, this signal gets - internally and invisibly - assigned to the “Out+/-” output.)

3.10.2 Connecting a Flag Indicator to the WIC1

Coil connection WI1SZ4

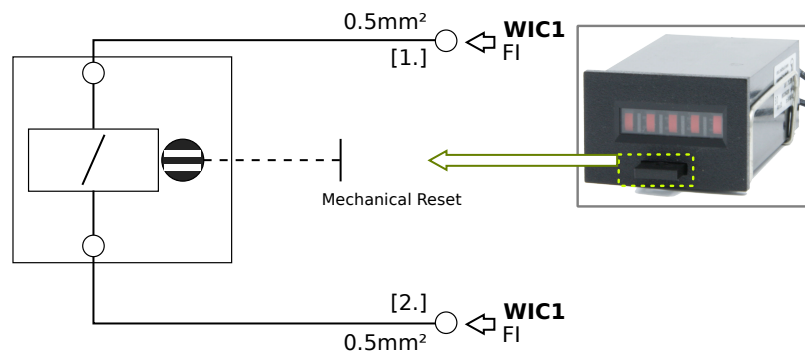

WI1SZ4_Z01

Fig. 39: Connection diagram for the WI1SZ4 flag indicator.

[1.] black cable, $\varnothing = 0.5\text{mm}^2$

[2.] black cable, $\varnothing = 0.5\text{mm}^2$

Coil connection W11SZ5

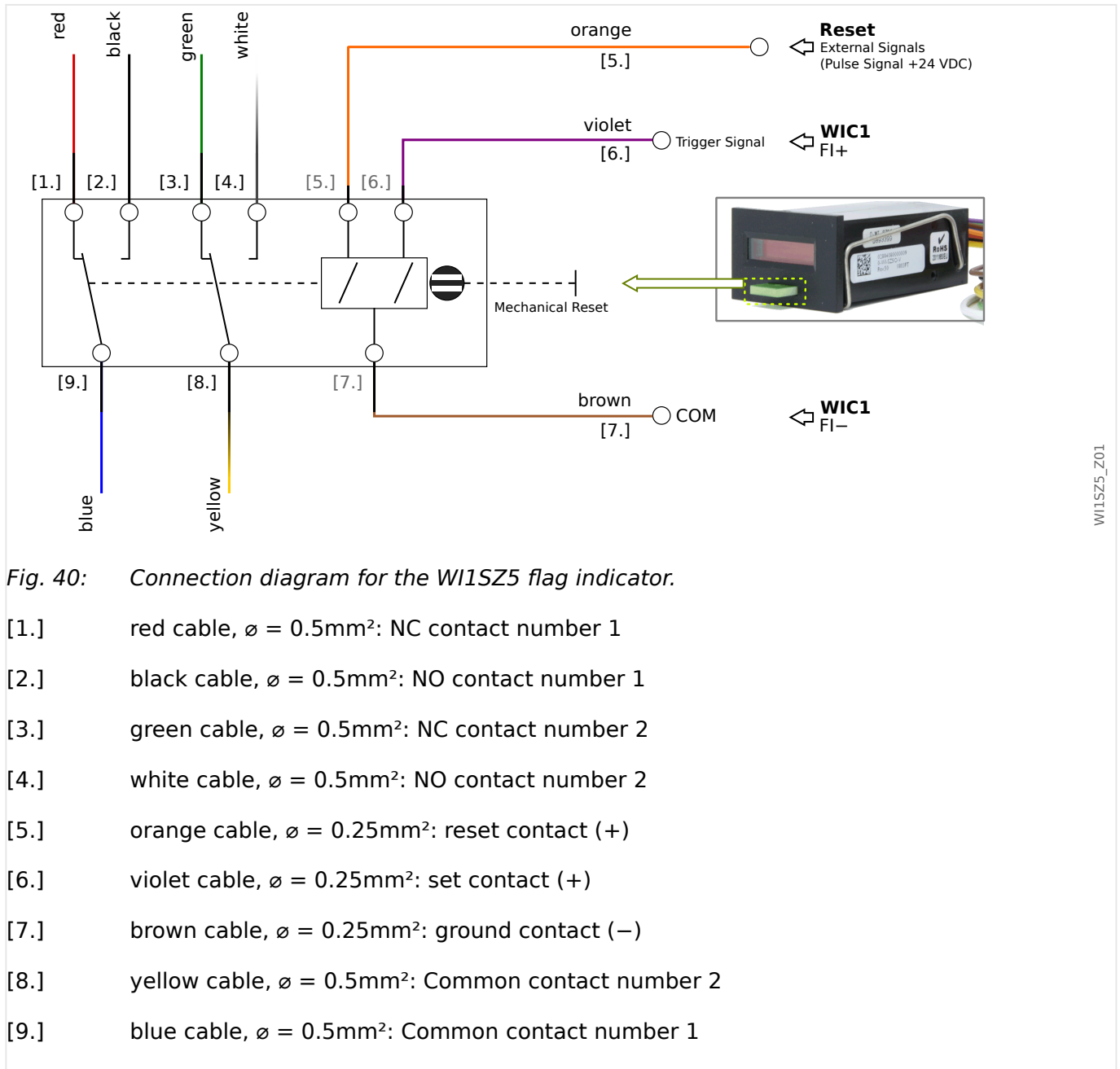

W11SZ5_Z01

3.10.3 Impulse Signal for the Flag Indicator

A flag indicator can be connected to terminals FI+/FI– (WIC1-4: Out+/Out–) of the terminal block X4, e. g. for a power-safe signaling of a trip.

The energy is provided by a capacitor store integrated in the WIC1 protection relay. The length of the trip impulse is approx. 50 ms, the pause between the individual pulses depends on the impedance of the flag indicator and the current level. Pulsing is continued until the assigned signal drops off.

Technical Data for the Setting Pulse

- Energy: $E \approx 0.01 \text{ Ws}$
- Voltage: $V \approx 24 \text{ VDC}$

CAUTION!



It is not allowed to connect any continuous / active voltage to the setting contact or to the reset contact of the flag indicator!

Any continuous voltage can destroy the coil that is built into the flag indicator.

For a WIC1-4, in particular, it is not permissible to connect a flag indicator and set the operating mode of the output to »Prot. Out. Mode« = „Syst. O.K. & Ext.Suppl.“ (see ↪“Relay Output (WIC1-4)”).

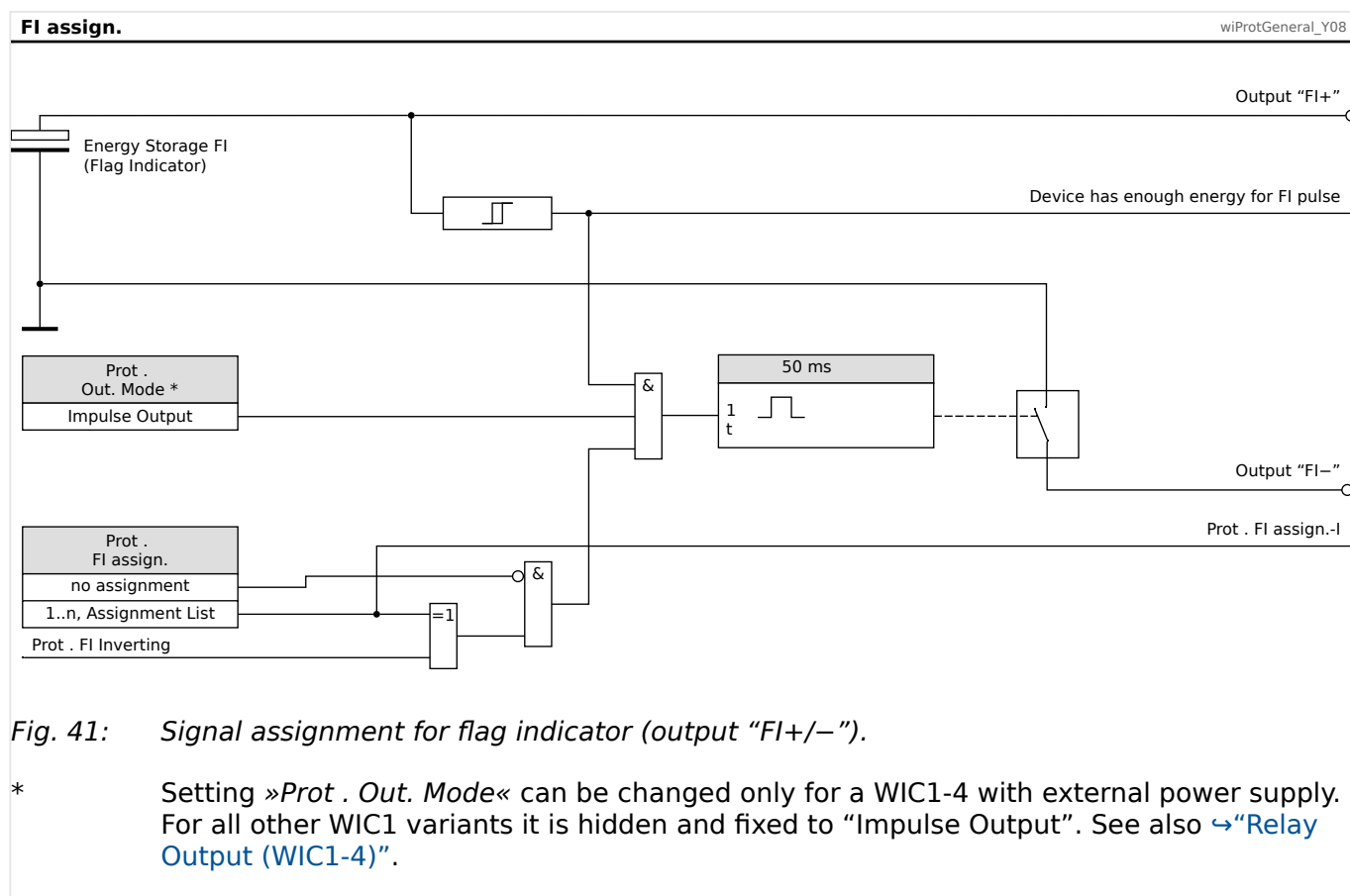

3.11 LEDs

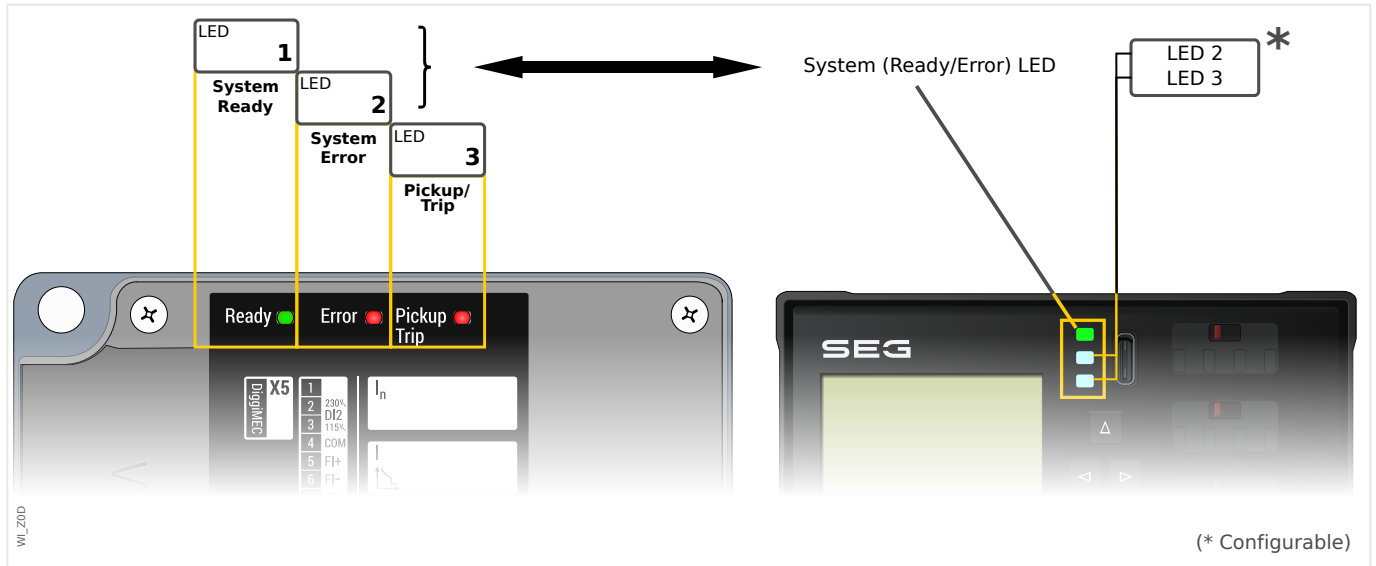

WIC1 LEDs

The WIC1 features one green LED and two red LEDs.

- The green and the first red LEDs are the »System« LEDs and have fixed functionality i.e. cannot be configured. See →“The »System« LED(s) - “Ready”, “Error””.
- The second red LED, labeled “Pickup / Trip”, indicates a (General) Pickup by blinking, and a (General) Trip by shining constantly red. It cannot be configured. (See also →5.1.1 General Pickup, General Alarm, General Trip.)

(Of course, in case of a CT-powered WIC1, any LED can be lit only until the breaker has interrupted the power supply.)

DiggiMEC LEDs

The DiggiMEC features three two-colored (red/green) LEDs. As long as the DiggiMEC is connected to the WIC1 there is the following functionality:

- The first LED corresponds to the two »System« LEDs (i. e. the LEDs “Ready” and “Error”) of the WIC1. See →“The »System« LED(s) - “Ready”, “Error””.
- The second and third LED can be configured by the user. (See →3.11.2 LED Configuration (DiggiMEC).)

The »System« LED(s) - “Ready”, “Error”

After booting is complete and all the protection functions are »activated« and there is enough energy for issuing a trip impulse signal, the green »System/Ready« LED lights up.

NOTICE!



The green “System/Ready” LED has the fixed (non-configurable) meaning: “Ready to Trip”.

This meaning is more strict than a simple “device is running”. Therefore it is possible (for example if the WIC1 is solely supplied via USB) that the WIC1 is running, so that you can configure it and/or read out measuring values, but the “System/Ready” LED is **off** (e. g. because the 5 Volts of a USB interface are o.k. for the operation of the WIC1, but do not suffice for the availability of a ~24 Volts trip pulse).

More details about the »System« LED(s) can be found in the table below, in [↔7 Self-Supervision](#) and in [↔11 Troubleshooting](#).

(WIC1 / DiggiMEC) System-LED: Built-in Signals	WIC1 (Green) System Ready LED	WIC1 (Red) System Error LED	DiggiMEC Two-Colored (Green+Red) System LED
<p>Device not ready (yet). This can also be the case if the software has completely started, but the WIC1 has not (yet) collected enough electrical energy for a trip pulse.</p> <p>Or: The phase currents are not sufficient for the WIC1 so that it is still switched off.</p> <p>Or: The device has been restarted into the “Service Mode” operating mode. In this mode, it is possible to reset all settings to the factory defaults, or to install a firmware update.</p> <p>(Further Infos on the “Service Mode”: ↔3.13.1.3 Special Keys During Power-on)</p>	OFF	OFF	OFF
<p>WIC1 has completely booted, the protection functions are running and there is enough electrical energy for a trip pulse.</p>	Constant Green	OFF	Constant Green, or Flashing Green (see also ↔Table)
<p>Green LED: as above i. e. the WIC1 has collected enough electrical energy for a trip pulse.</p> <p>Blinking red color: The WIC1 has done an automatic restart (due to a device-internal error) and entered a “Protection-Only” operating mode. In this mode, only the protection and supervision functions have been started. (This might hopefully reduce the risk of another error.)</p> <ul style="list-style-type: none"> In particular, all communication functions are inactive, including connections with DiggiMEC and Smart view. The DiggiMEC flag indicators / output relays, however, should be functional. Although the protection functionality is fully active it is recommended to check (and/or replace) the WIC1. 	OFF, or Constant Green	Blinking red	Blinking Red, or Blinking Red ↔ Green
<p>A serious error has been detected, so that the WIC1 could not start as normal, but at least the (hardware-based) backup protection is up and running. (See ↔7.3 Backup Protection / Self-Supervision.)</p> <ul style="list-style-type: none"> Since only the backup protection is active the WIC1 needs to be replaced as soon as possible, and you should contact SEG Support. 	OFF	Constant Red, or OFF	<ul style="list-style-type: none"> Constant Red: if the DiggiMEC is connected to a PC via USB (so that there is an external power supply) OFF: without supply

DiggiMEC System-LED: Additional DiggiMEC-specific LED Signals	DiggiMEC Two-Colored (Green+Red) System LED
If the display is not available the DiggiMEC is not supplied with electricity, neither from the WIC1, nor via the USB interface from a connected PC.	OFF
<p>If the display is available (but the LED is OFF):</p> <ul style="list-style-type: none"> • The DiggiMEC is properly connected to the WIC1, but the WIC1 reports that protection or tripping is not (yet) available. • Or: The WIC1 has been restarted into the “Service Mode” operating mode. In this mode, it is possible to reset all settings to the factory defaults, or to install a WIC1 firmware update. • Or: The DiggiMEC has been restarted into the “Service Mode” operating mode. In this mode, it is possible to install a DiggiMEC firmware update. <p>(Further Infos on the “Service Mode”: ↪3.13.1.3 Special Keys During Power-on)</p>	OFF
<p>WIC1 has completely booted, all protection functions are running and there is enough power for a trip pulse.</p> <p>But the power supply by the CTs is not sufficient for the HMI of the DiggiMEC, which therefore stays inactive. (Exception: The blinking LED, and the flag indicators / output relays, which should all be functional).</p>	Flashing Green
If the LED is lit constantly red it means that the DiggiMEC is supplied with electricity via the USB interface from a connected PC, but there is no connection to the WIC1.	Constant Red

3.11.1 WIC1-LED for "Pickup / TripCmd"

The third LED WIC1 is labeled "Pickup / Trip" and has indeed a double functionality:

- Blinking red — (General) Pickup.
Constant Red — Trip Command.

Since there is no latching there is no need for a reset of the LED. See also [↔5.1.1.1 Trip Pulse and WIC1 LEDs](#).

3.11.2 LED Configuration (DiggiMEC)

Apart from the green LED for System OK (that has a fixed function), each LED can be configured via the following parameters within menu branch [Device Para / DiggiMEC / LEDs]:

- »Assigned signals«: The parameters »LED2 assign. 2« and »LED3 assign.« can be used to assign a trigger signal to "LED number x".

Special case: Whenever a **trip signal** is assigned to a LEDx, the corresponding **pickup signal** gets signaled as well (via particular blinking patterns), see [↔3.11.4 Latching of a DiggiMEC-LED with an Assigned Trip Signal](#).

- »Latching / self-holding function«: If »LED2 latching« / »LED3 latching« is set to anything other than "No latching", the state that is set by the trigger signal is permanently stored. (For details see [↔3.11.3 Latching of the DiggiMEC LEDs](#).)

With the setting "No latching", the LED always adopts the state of the assigned signal.

- »LED2 Color« / »LED3 Color«: This defines an "active" color, or a pair of "active + inactive" colors. The LED lights up in this "active" color if the assigned trigger signal is active, and it can light up in the other ("inactive") color if the trigger signal is inactive. Available setting values are:
 - „Red“ - The "active" color is red. (No "inactive" color, i. e. the LED is off when the assigned signal is inactive.)
 - „Green“ - The "active" color is green. (No "inactive" color.)
 - „Green / Red“ - The "active" color is red, and the "inactive" color is green.



An LED test is always also executed together with the reset: All LEDs flash in red color for (approx.) a second, then flash in green color for (approx.) a second.

3.11.3 Latching of the DiggiMEC LEDs

After the assigned signal has become active a latched LED keeps its state until it is acknowledged, or some automatic reset occurs.

A latched LED gets reset only in any of the following cases and only after the assigned trigger signal has dropped out.

The following latching modes are settable via »LED2 latching« / »LED3 latching«:

- “No latching” - No latching, the status always follows the status of the assigned signal.
- “With latching” - With latching, i.e. the state remains active once the the assigned signal has become active. (After the assigned signal has dropped off the state can be reset by the device.)

A reset is then possible via the Direct Control [Operation / Reset] »Rst. LEDs, Fls«, see also [↪2.11 Reset](#).

- „Latch. w. Auto-Reset“ - latching with automatic reset, see also [↪2.11.1 Automatic Reset](#).

A latched LED state “survives” a complete power-off, i. e. the state is stored in a permanent part of the memory. With the next restart, the LED light up again (or continues its [blinking/flashing](#)).

3.11.4 Latching of a DiggiMEC-LED with an Assigned Trip Signal

Special case: Whenever a **trip signal** is assigned to a LEDx, the corresponding **pickup signal** gets assigned as well, with the following behavior:

- When the corresponding pickup signal occurs, the LEDx starts blinking.

With latching, this continues until a reset is done or until the assigned trip signal occurs. (Reset: See [↪2.11 Reset](#).)

- When the assigned trip signal occurs, the LEDx is lit.

With latching, this continues until a reset is done. (Reset: See [↪2.11 Reset](#).)

- Moreover, there is the following additional behavior with latching:

When a pickup - without a trip - occurs and drops off again, the LEDx starts flashing (with flashing pattern OFF : ON ≈ 10 : 1).

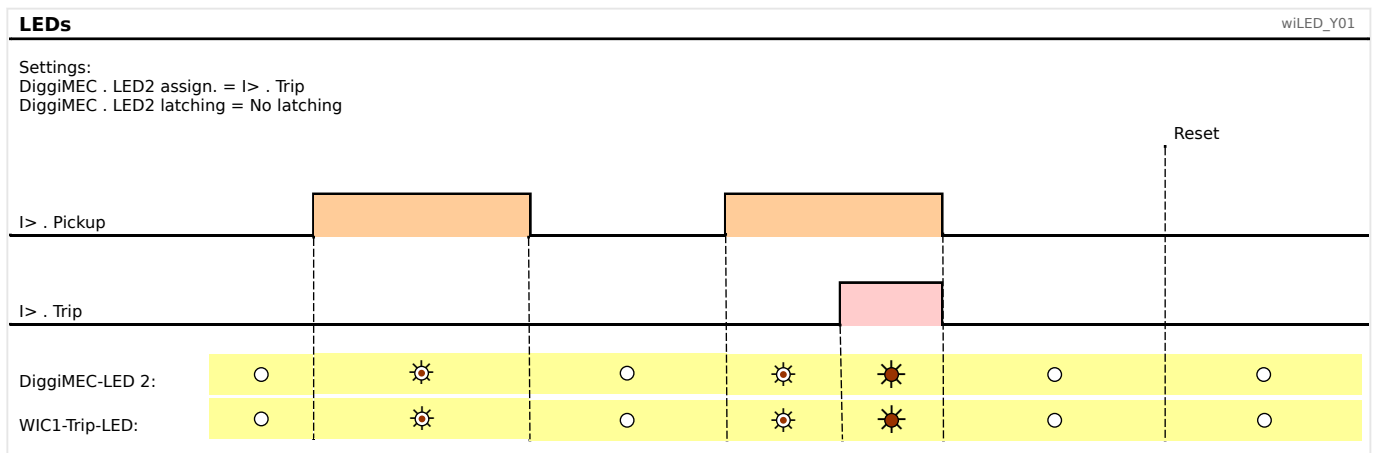

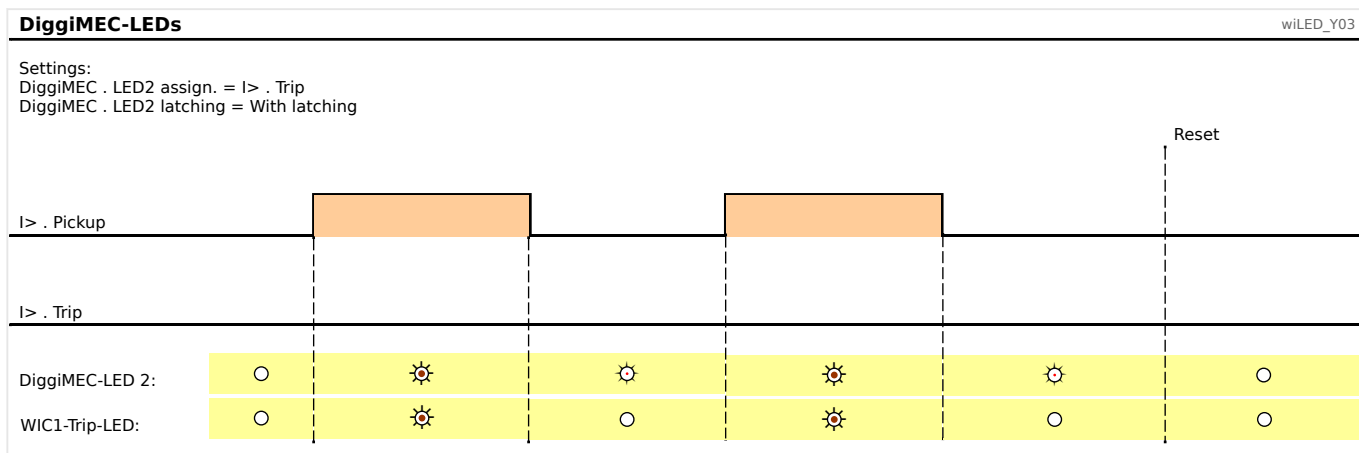
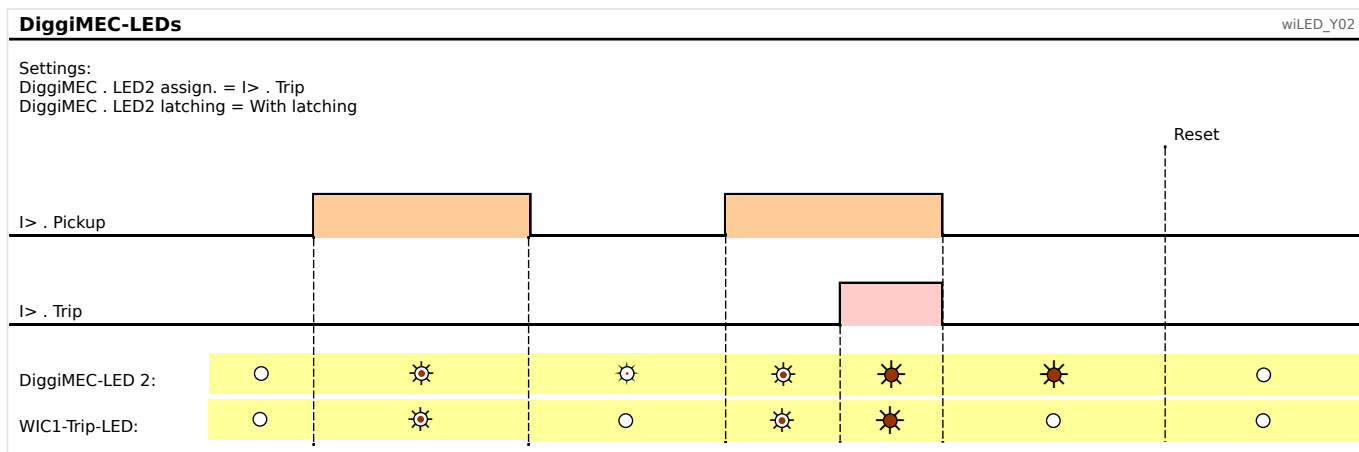

Symbols

	The LED is OFF.
	The LED is flashing (i. e. is blinking with an OFF : ON pattern of 10 : 1).
	The LED is blinking.
	The LED is lit continuously.

(Even though the diagrams are showing the settings for LED 2 this is only an example, of course. The analogous settings can also be made for LED 3, resulting in the same signal flow.)

The WIC1 Pickup / Trip LED is shown only for completeness and for comparison: In fact, the WIC1 Pickup / Trip LED does not support any latching.

3.12 PC4 adapter - PC Interface for WIC1

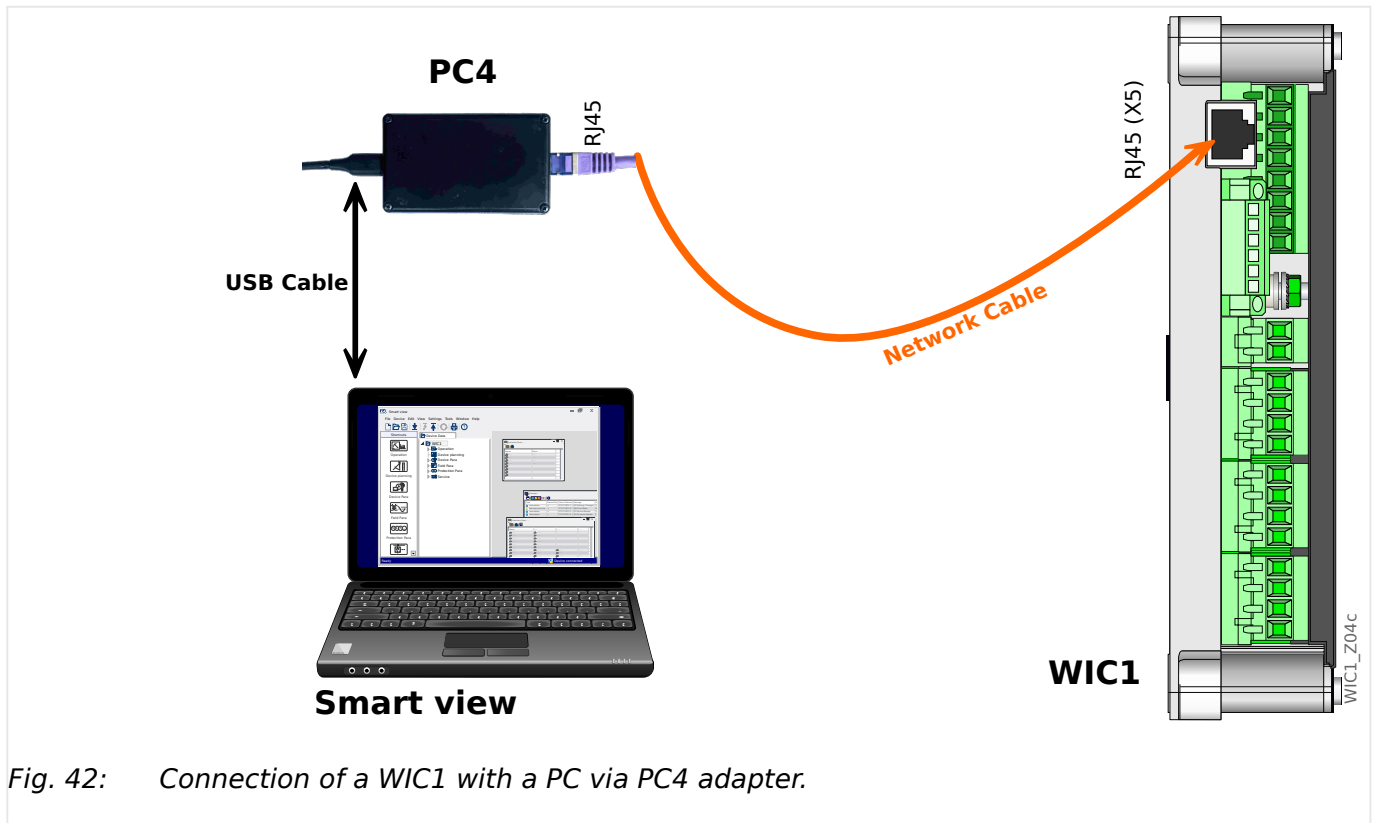

Fig. 42: Connection of a WIC1 with a PC via PC4 adapter.

The PC4 adapter connects a Windows PC to a WIC1, so that the parameter setting and evaluation software *Smart view* can be used to configure the WIC1 and to retrieve measurement values and fault data from it.

Use a standard USB-C to USB-A cable for the connection between the PC/laptop and the PC4 adapter. During the connection both PC4 adapter and WIC1 are supplied from the 5V USB source.

For the connection between the PC4 and the WIC1 protection unit, use an Ethernet (RJ45) cable.

Depending on your Windows version, you might need to download and install the latest VCP driver from: www.ftdichip.com/. (On the main page, click menu items "Drivers".)

Software for P/N WIC1PC4 and the setting software *Smart view* can be downloaded from the SEG download area: <https://docs.segelectronics.de/>

Firmware Update via PC4 adapter: For updates to R2.2 and later releases a PC4 adapter can be used as an alternative to a DigiMEC.

CAUTION!

Use an Ethernet cable CAT 3 (or better) with shielding for the connection between WIC1 and PC4 adapter. **Crossover cables must not be used!**

Make sure that the connection cable between WIC1 and DiggiMEC is mounted according to all regulations! Respect the manufacturer's specifications about permissible bending radii, and prevent defects by appropriate means such as cable conduits, e. g. if the cable needs to be bent around sharp corners.

A defective cable might impair the internal voltage of the WIC1 and PC4 adapter, and this might affect the capability of the device to operate a trip coil and outputs.

The PC4 adapter is only designed for temporary connection to the WIC1. e.g. during commissioning.

CAUTION!

Only PC4 adapter and DiggiMEC are permitted for connection with the RJ45 (X5) terminal of the WIC1 g2. Connecting a PC3 adapter or other equipment may damage the relay and lead to failure of protection!

3.13 DigiMEC® - Nano HMI with optional Flag Indicators and Output Relays

The **DigiMEC®** is a remote HMI to be used in connection with a **WIC1** (generation 2) protection relay. (It cannot be used with the predecessor WIC1.)



DigiMEC® is a registered trademark. For the sake of readability, most chapters of this User Manual omit the “®” designation. This, however, does not mean that the term “DigiMEC” can be used without any restrictions.

An overview of the elements and connectors can be found here: [↪3.13.1 Navigation - Operation](#), and here: [↪3.13.2 DigiMEC Connectors](#)

Information about the LEDs and their configuration is here: [↪3.11 LEDs](#)

Connection of the DigiMEC

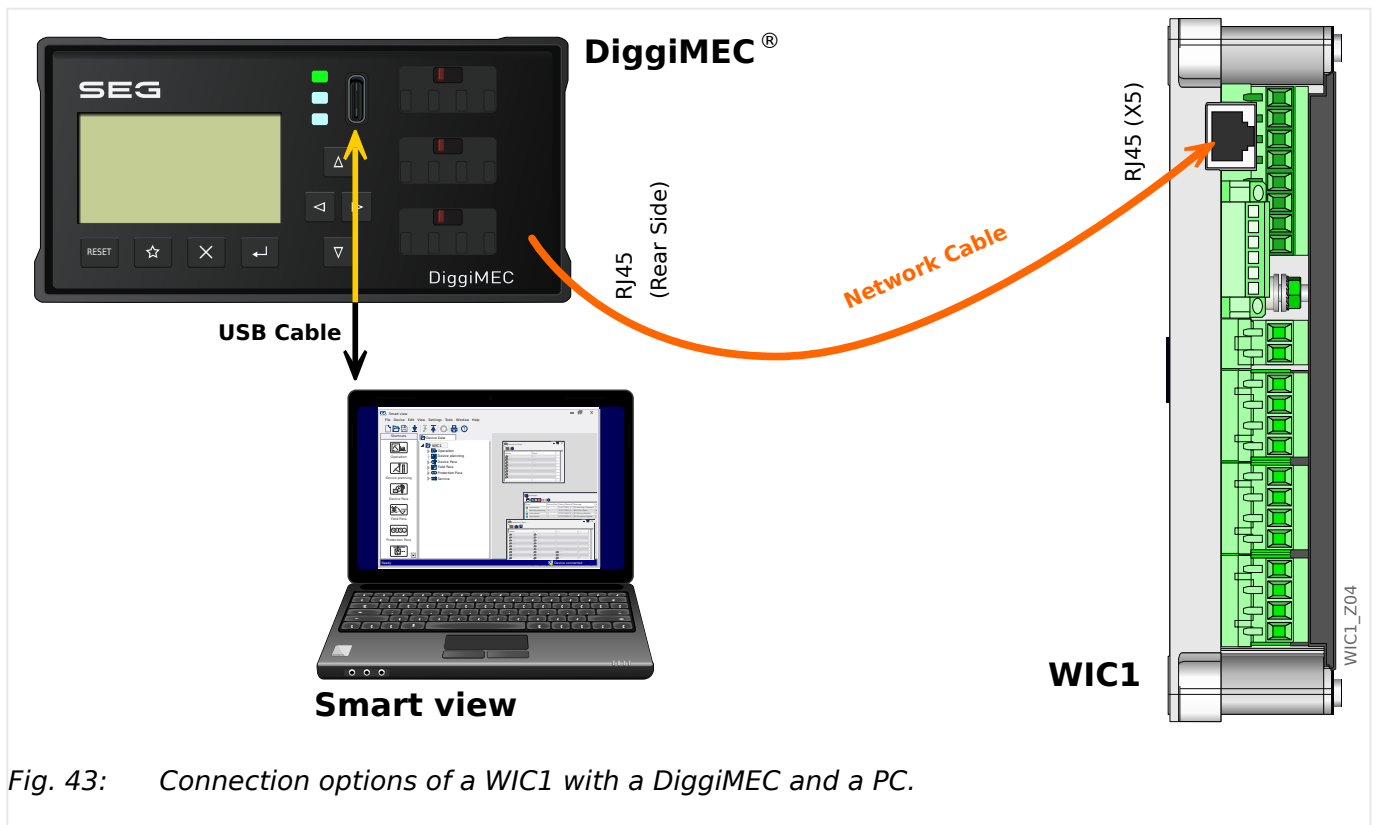

Fig. 43: Connection options of a WIC1 with a DigiMEC and a PC.

The WIC1 can be (optionally) connected to the interface device DigiMEC, which adds an LCD display, keys and, depending on the [ordered type](#), 0/1/3 flag indicators. Each flag indicator is mechanically related to a bistable output relay.

The DigiMEC can be connected to a Windows PC, so that the parameter setting and evaluation software *Smart view* can be used to configure the WIC1 and to retrieve measurement values and fault data from it. Moreover, the WIC1 can trigger the flag indicators / output relays.

CAUTION!

Use an Ethernet cable CAT 3 (or better) with shielding for the connection between WIC1 and DiggiMEC. **Crossover cables must not be used!**

Make sure that the connection cable between WIC1 and DiggiMEC is mounted according to all regulations! Respect the manufacturer's specifications about permissible bending radii, and prevent defects by appropriate means such as cable conduits, e. g. if the cable needs to be bent around sharp corners.

A defective cable might impair the internal voltage of the WIC1 and DiggiMEC, and this might affect the capability of the device to operate a trip coil and outputs.

NOTICE!

The DiggiMEC is always usable only with a connected WIC1 g2 (independent of whether there is any supply via the USB interface of the DiggiMEC).

Please make sure DiggiMEC and WIC1 have compatible firmware versions. For example, a WIC1 with DM version 2.3 requires a DiggiMEC with DM version 2.3. Otherwise the DiggiMEC will not work as an HMI and can only be used for connection with a Windows PC via *Smart view*. In this case the display of the DiggiMEC shows the message "**Panel not available**".

3.13.1 Navigation - Operation

The following illustration shows the elements on the DiggiMEC front:

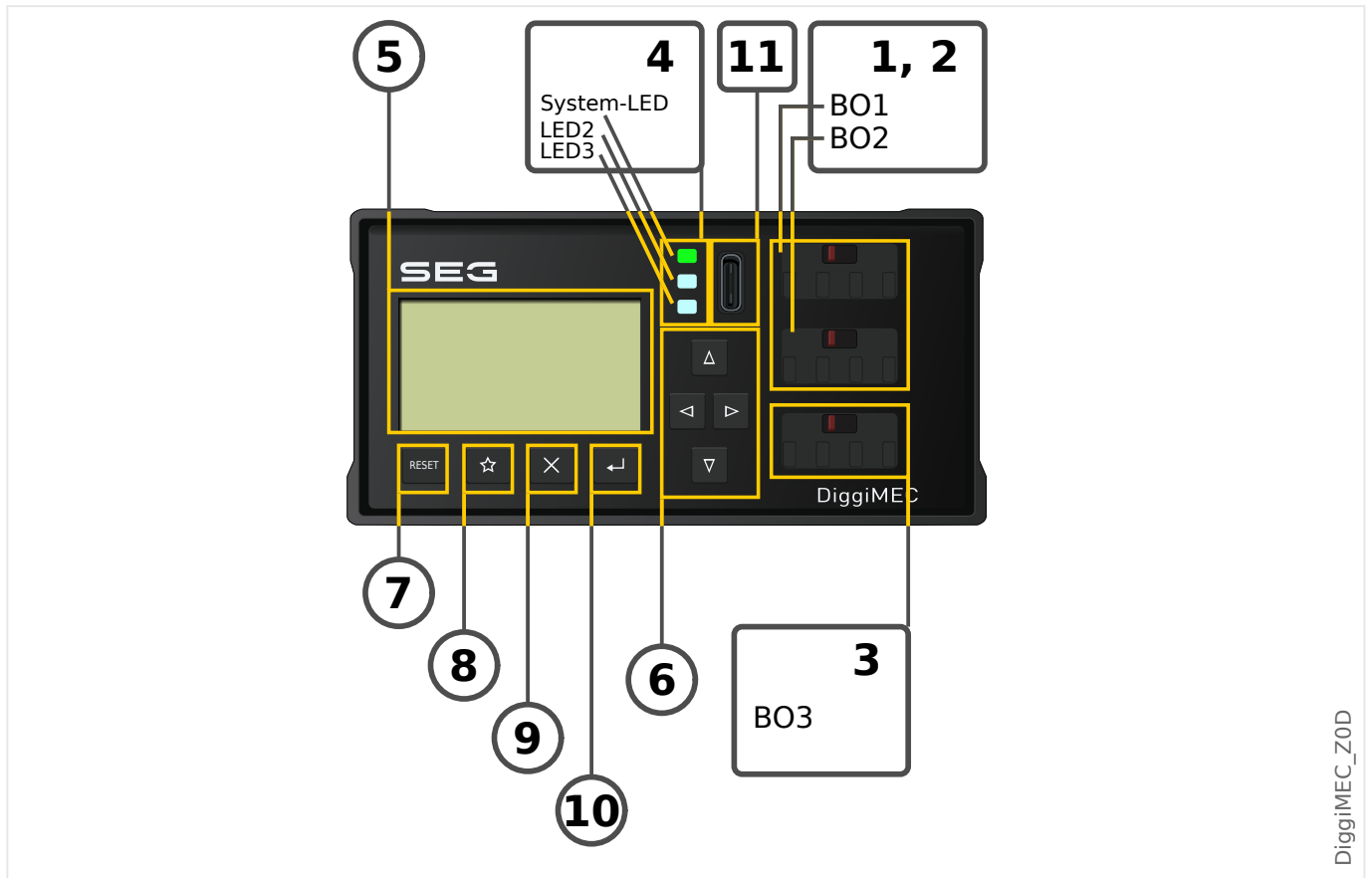

3.13.1.1 Front Panel Parts

(1), (2), (3) Output Relays / Flag Indicators

The number of output relays and flag indicators depends on the **ordered type**:

- DiggiMEC-0: 0 output relays.
- DiggiMEC-A: 1 output relay BO2.
- DiggiMEC-B: 3 output relays BO1, BO2, BO3.

Each flag indicator is mechanically connected with a bistable output relay.

(1), (2) The flag indicators BO1, BO2 have one “Form A” (normally open) contact each.

(3) The flag indicator BO3 has a “Form C” (changeover) contact.

See also [↔3.13.2 DiggiMEC Connectors](#).

(4) LEDs

The DiggiMEC features three two-colored (red+green) LEDs. The first (upper) »System« LED has fixed functionality and (roughly) corresponds to the WIC1-LEDs »READY« and »ERROR«.

The »System« LED is constantly green (or flashing) when everything works OK. This means, in particular:

- The connection to the WIC1 has been established.
- The WIC1 has successfully started all protection functions.
- The WIC1 has stored sufficient electrical energy to issue a trip impulse.

See also [↔3.11 LEDs](#). In case of problems consult [↔11 Troubleshooting](#).

The other two LEDs are programmable. This means they can be assigned with WIC1-signals, so that they can inform you about operational states, system data or other WIC1 particulars.

Various signals can be freely allocated to LEDs out of an »assignment list«. (The available signals can be found in the WIC1 Reference Manual.)

(5) Display

Via the display you can check operational data and edit parameters (of the connected WIC1).

(6) ... (10) Keys

The keys usually react on a short key-press at the moment when the key is released. Exceptions are the Repeat-functionality of ▲ »Up« und ▼ »Down« and the [Special Keys During Power-on](#).



After some time without any keystroke the backlight of the display goes off. Note that then, while the display backlight is off, the first keystroke does nothing but illuminating the display (i. e. the normal key function is ignored).

(6) Navigation Keys

The functions of the keys “◀” (Left), “▶” (Right), “▲” (Up), “▼” (Down) are contextual.

- ◀ In general, the "Left" key is used to go one step back. You can leave a submenu. You go back to the previous page of the menu tree.
- ▶ In general, the "Right" key is used to enter the currently selected submenu.
- ▲ In general, the "Up" key is used to scroll upwards. You go to the prior menu point/one parameter up by scrolling upwards.
- ▼ In general, the "Down" key is used to scroll downwards. You go to the next menu point/one parameter down by scrolling downwards.

The ▲ »Up« und ▼ »Down« keys have a Repeat-functionality. If you hold the keys pressed for some time, the key-stroke gets automatically repeated again and again. This allows for quickly browsing through a long list.

(7) »Reset« Key

A key-press resets latched signals (including latched LEDs, flag indicators and the Fault Display screen).

See [↔2.11 Reset](#) for details.



An LED test is always also executed together with the reset: All LEDs flash in red color for (approx.) a second, then flash in green color for (approx.) a second.

(8) »★« Key

The “Favorites” key allows for an immediate access to often used menu branches. See [↪3.13.1.2 Favorites Key »★«](#) for details.

(9) »X« Key

The “Cancel” key aborts parameter changes.

(10) »↵« Key

The »↵« (»Enter«) key can be used to select new parameter values out of a selection list or value setting dialog. In any other dialogs the »Enter« key is used to store prepared parameter changes: By pressing the »Enter« key once the parameter changes are temporarily stored. These settings are marked by an asterisk symbol (“*”) on the display, they have not been transferred to the WIC1 yet and are therefore not effective yet. If the »Enter« key is pressed again, those changes are stored definitely.

(11) USB Interface (Smart view Connection)

Connection to the PC software *Smart view* can be done via this USB-C interface.

Moreover, this is a sufficient power supply for DiggiMEC and WIC1, in case the WIC1 is not supplied via the CTs or any auxiliary power (WIC1-4 only).

3.13.1.2 Favorites Key »★«

The “Favorites” key »★« allows for an immediate access to often used menu branches.

For the current Version, there is a fixed list of entries. (It is planned to allow for individual choices in a later Version.)

The diagram shows the SEG interface with a 'Favorites' menu. The menu contains a star icon and the text 'Favorite F1'. Below the menu are four buttons: 'RESET', a star icon, a close icon (X), and a back icon (left arrow). A hand icon is shown pressing the star icon, labeled with a circled '1'. To the right, a legend lists four favorite functions: F1 [Operation / Measured Values / Current], F2 Fault/Alarm Rec., F3 [Operation / Reset], and F4 Internal messages. Below the legend, a hand icon is shown pressing the star icon, labeled with a circled '2'. To the right, a hand icon is shown pressing the back icon, labeled with a circled '3'.

F1 [Operation / Measured Values / Current]
 F2 Fault/Alarm Rec.
 F3 [Operation / Reset]
 F4 Internal messages

(1) Press “★” (several times) to call the Favorites one after the other.

(2) Afterwards, you can navigate as usual (with “▲” and “▼”) and/or enter a details screen (by pressing “▶”).

(3) Leave the Favorites menu by pressing “◀”.

DiggiMEC_Z09

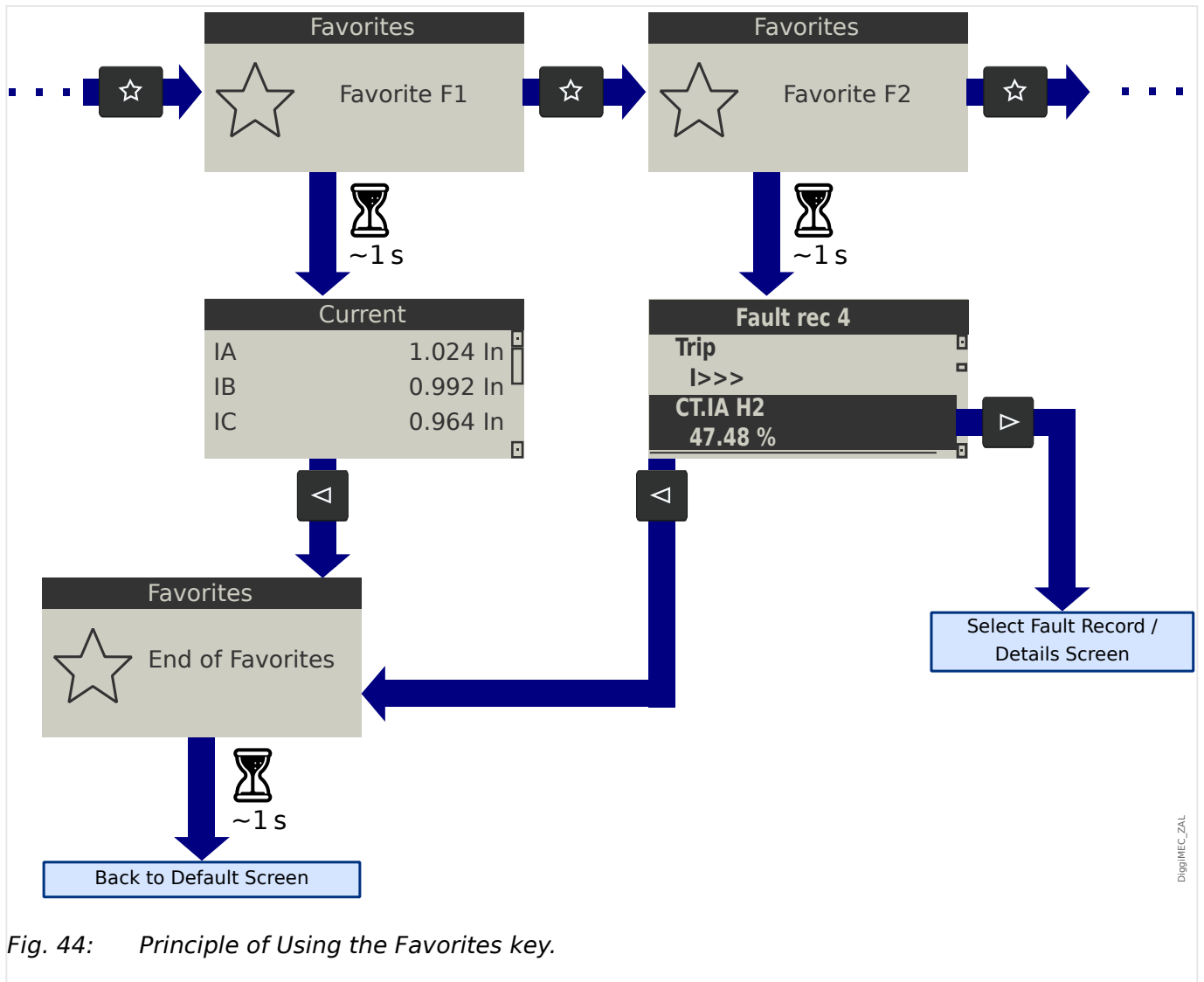

Fig. 44: Principle of Using the Favorites key.

3.13.1.3 Special Keys During Power-on

Some keys have a special functionality when being pressed during the power-on / boot process.

- **»⇐« during power-on** - After a confirmation dialog, the DiggiMEC enters a special "Service Mode". This operating mode allows for installing a new firmware on the DiggiMEC.
- **»Reset« during power-on** - After a confirmation dialog, the WIC1 enters a special "Service Mode". This operating mode allows for installing a new firmware on the WIC1.
- **»X« during power-on** - After a confirmation dialog, the WIC1 resets all settings to the respective factory default.

This is the same functionality as the Direct Control [Service / General] »Factory Reset«, see [↪2.12 Reset to Factory Defaults](#).

WARNING!



As long as the WIC1 is running in „Service Mode“, your equipment is protected only by the Backup protection, not by the user settings.



This means that the Backup Protection of the WIC1, especially the WIC1-#xxxxxx**1**xxx (“Backup Protection trip as soon as possible”) variant, might output a trip pulse. Therefore it is strictly recommended to always enter the „Service Mode“ only with the breaker opened (or disconnected).

3.13.1.4 Menu Structure

The menu structure offers the following top-level menu entries. You enter a menu branch with the »►« key. The keys »▲« and »▼« let you navigate to the previous or next one. The key »◀« leaves a menu branch so that you go to the previous or to the super-ordinated view.

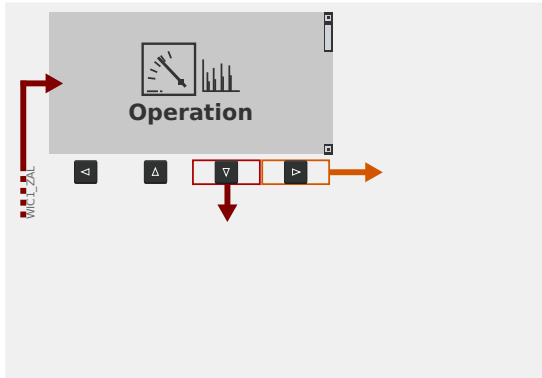
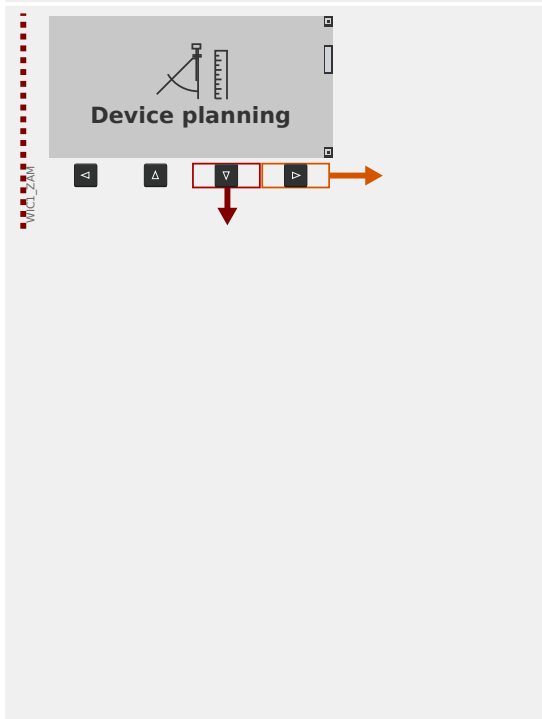
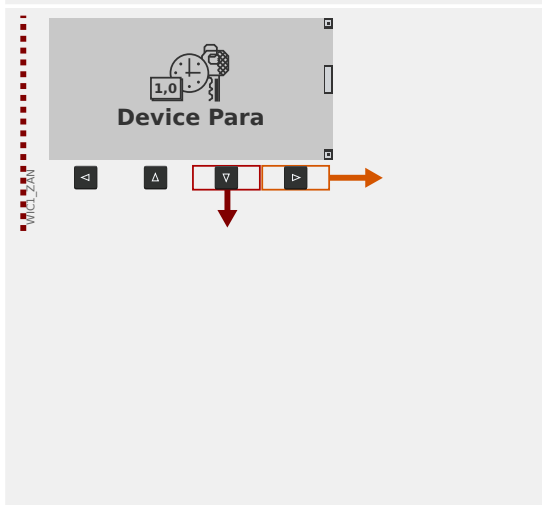
A complete documentation of all WIC1 menu branches, parameters, direct commands and values in tabular form can be found in a separat document, the “WIC1 Reference Manual”.

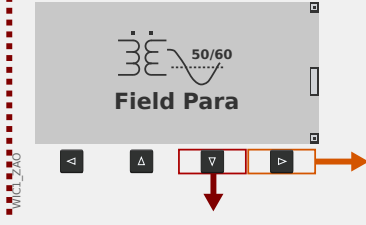
	<p>Operation</p> <p>Here you can find run-time data.</p> <ul style="list-style-type: none">• Measured Values• Status Display• Recorders• Self-Supervision• reset
	<p>Device planning</p> <p>This will usually be your first step during commissioning:</p> <ul style="list-style-type: none">• Within sub-menu WIC1 + DiggiMEC, you can specify fundamental properties of your device setup. In particular, you can define for a WIC1-2 (with DIP switches) or WIC1-3 (with HEX switches) whether the protection configuration shall be made via switches or via DiggiMEC / Smart view. (See →Chapter 2.2.2 for details.)• Within sub-menu Projected Elements, you can activate the elements that you need, and deactivate elements that are not needed.• Within sub-menu Definition, you can define for each element (if it makes sense) whether it shall operate as a protection function (i. e. being able to trip the circuit breaker) or as a supervision function (i. e. issuing an alarm message instead of a trip signal).
	<p>Device Parameters</p> <p>This menu branch features all settings that are directly related to the device, for example:</p> <ul style="list-style-type: none">• Inputs and outputs• (DiggiMEC) LEDs• Settings for the automatic reset and – for some WIC1 variants – for the external reset• Password setting• In sub-menu Version, you can check all versioning details about the running WIC1 firmware and DiggiMEC firmware.

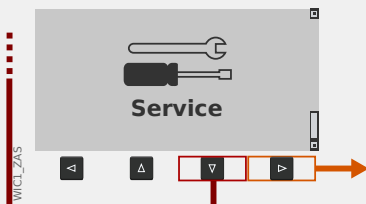
	<p>Field settings</p> <p>Usually the second commissioning step: Configure the properties of the field, for example:</p> <ul style="list-style-type: none">• Nominal frequency, current• CT ratios
	<p>Protection Parameters</p> <p>All protection settings, which are related to a specific protection function, can be found here in various sub-menus.</p>
	<p>Service</p> <p>This menu branch contains some special functions:</p> <ul style="list-style-type: none">• Force a WIC1 restart.• Force a trip command.• Force a reset of all settings to their factory defaults.• Force a temporary transition of the WIC1 into the backup protection mode (for testing purposes).

3.13.1.5 Parameter Changes - "OK" key

Whenever setting values are being modified the key »↵« is used (which is also called »OK« or »Enter« key for the sake of simplicity). This makes the device accept the new value. But note that for modifying one value, the »↵« key must be pressed a second time: When pressing »↵« for the first time, the new value is stored temporarily. Only after it has been pressed for a second time, the new value (and all other changed values) get(s) activated. This way it is possible to prepare a lot of settings changes, and only after all changes have been made consistent and as required for the (new) protection concept they can be activated all at once.

NOTICE!

! Make sure that WIC1 and DiggiMEC are sufficiently supplied, especially when both are supplied by the CTs. A sag of the supply might result in losing all parameter changes that have not been transferred to the WIC1 yet.

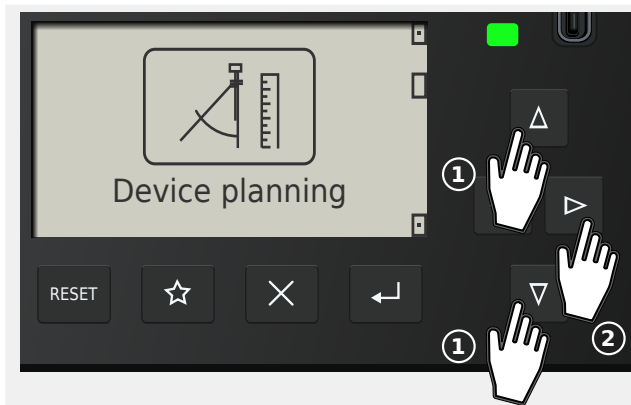

For example, let us assume we want to modify the value of »IG>> . Mode«.

This setting can be found in the [Device planning / Projected Elements] menu branch (which can be seen, for example, in the Reference Manual). The purpose of the parameter is to activate (or deactivate) the protection function »IG>>« (i. e. the 2nd stage of the Ground Overcurrent protection).

Use the arrow keys »▼«, »▲« to select Device planning menu branch, then »▶« to enter it.

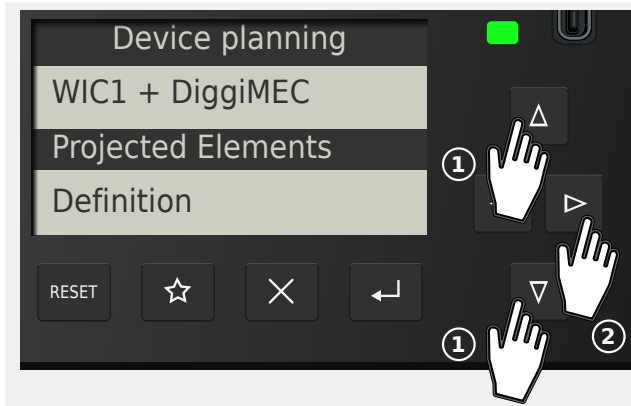

In the same way, select and enter the (sub-)menu item Projected Elements.

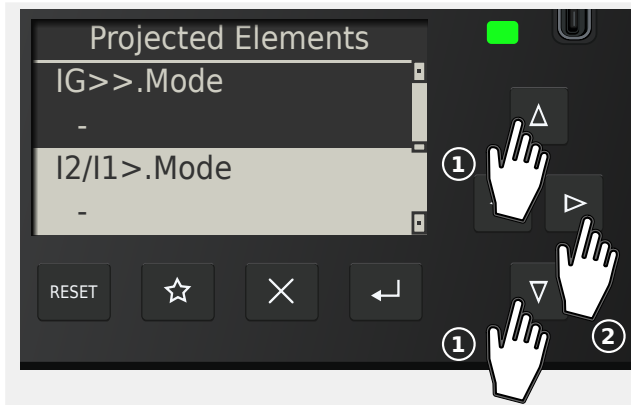

Then press »▼«, »▲« repeatedly, until the required setting appears highlighted on the display.

Press »▶« to enter the Edit Mode for this particular setting.



You are asked for the password.

On the DiggIMEC panel, the password is entered the same way as any numerical setting value, i. e. via navigation keys »◀«, »▶« for the position (= selection of the position/digit within the password) and »▼«, »▲« for increasing/decreasing the digit. The Enter key »↵« confirms the entered password. (A Smart view user enters the password simply via the PC keyboard.)

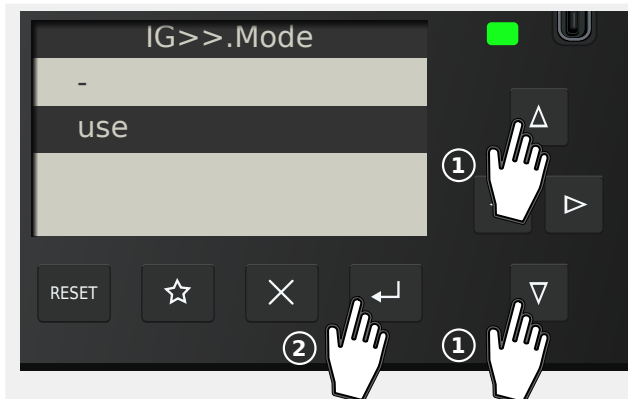

Press »▼«, »▲« repeatedly again, until the required value, for instance: “use”, is highlighted.

Then press the »↵« key, so that this new value gets stored (temporarily). (Or, alternatively, press the »✕« key to cancel the modification.)

Note that the new value is only stored internally, but not active yet, just as was already mentioned at the beginning of this chapter.

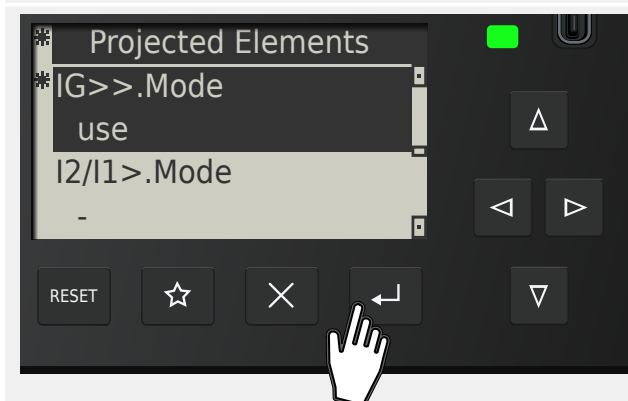

That first »↵« pressing that you have just done brings you back to the screen showing the selected parameter, »IG>> . Mode«.

However, some things have changed now:

- Now the new value “use” is shown.
- An asterisk character “*” next to the parameter indicates that there are temporary changes for it. In addition, another asterisk next to the heading line indicates that parameter changes exist that have not yet been accepted and activated by the device. (The “*” remains there, even if one navigates to some other menu branch.

Remark: If there is no more input made at the panel for 10 minutes the changes are automatically cancelled.

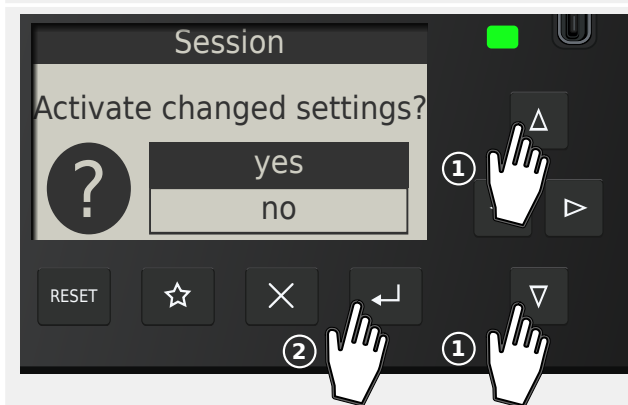

Press »↵« again. (In principle, this can also be done later, i. e. after some more parameter changes and when being in another menu branch.)

A confirmation dialog asks you to explicitly accept your changes. Make your choice in the usual manner with the keys »▼«, »▲«, »↵«.

3 Hardware

3.13.1.5 Parameter Changes - "OK" key

The protection device performs a validity check, and after this, it uses the new setting (unless it detects a validity problem).



If the validity check should fail, i. e. the protection device detects some validity problem or inconsistency with respect to the new value(s) then this is indicated by a big "?" character that appears instead of the "*" in the heading line. In this case the protection device refuses to activate the new value(s), and you are expected to re-edit the values that are marked by the "?".

3.13.2 DiggiMEC Connectors

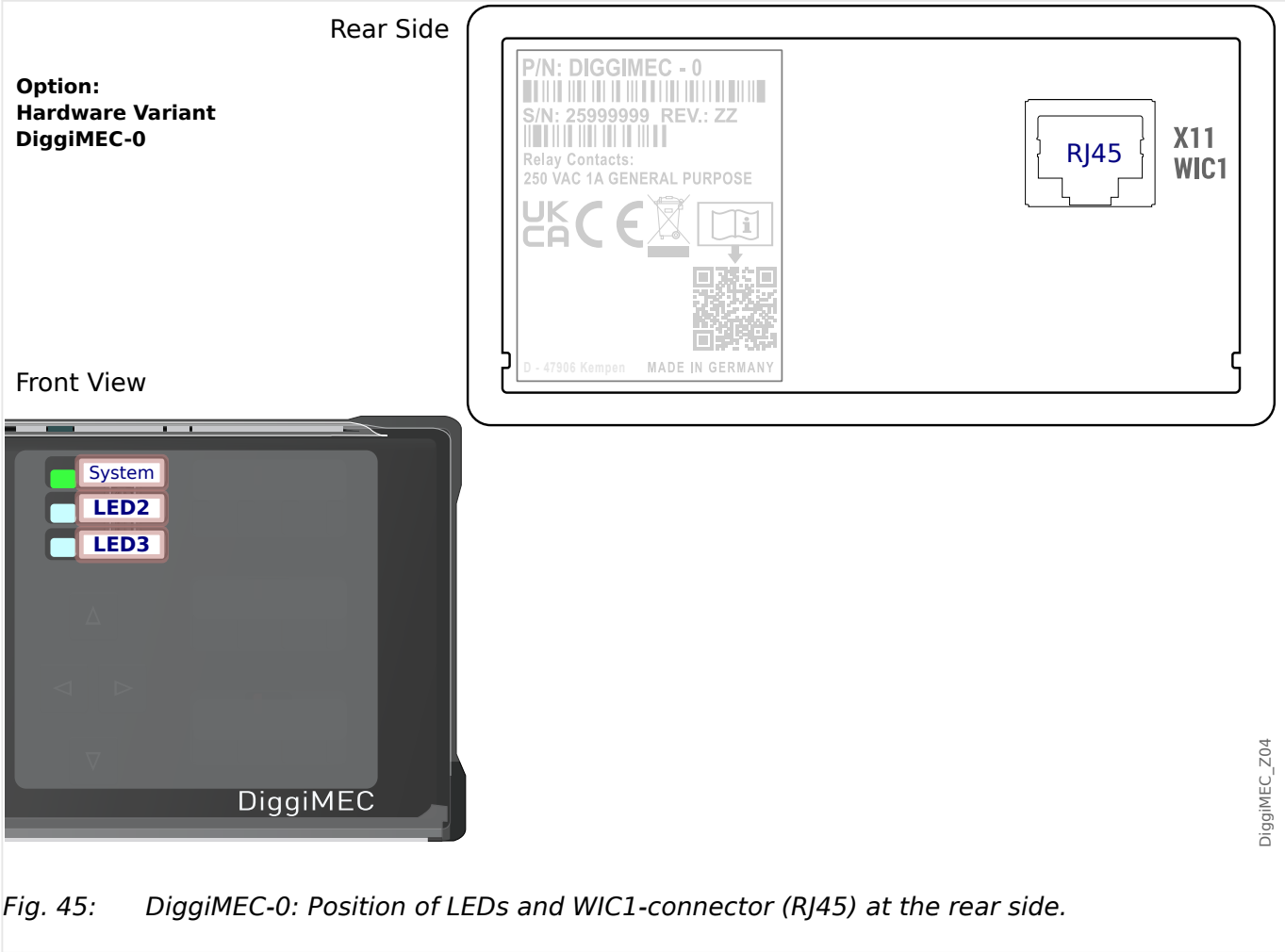
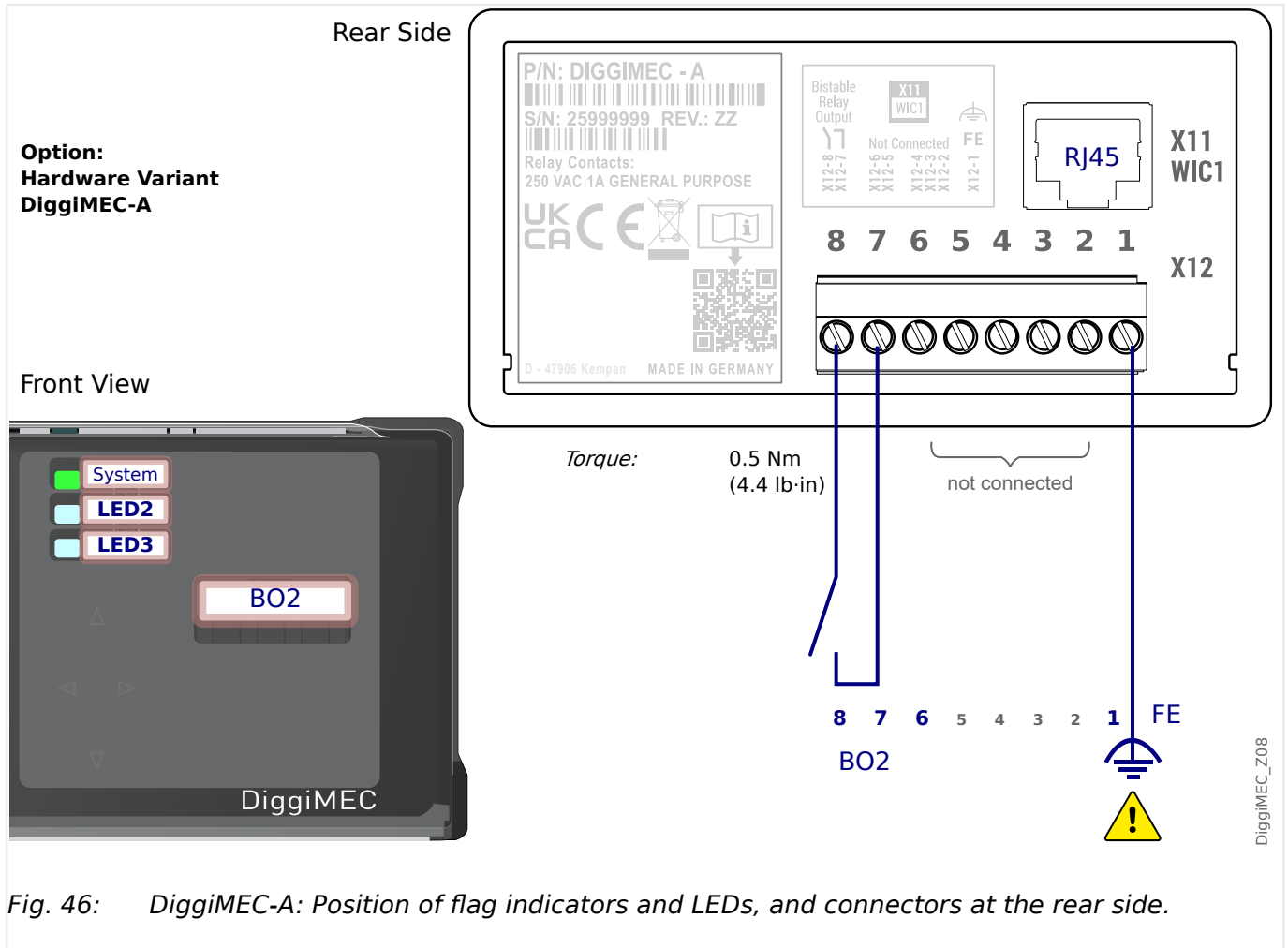

Fig. 45: DiggiMEC-0: Position of LEDs and WIC1-connector (RJ45) at the rear side.



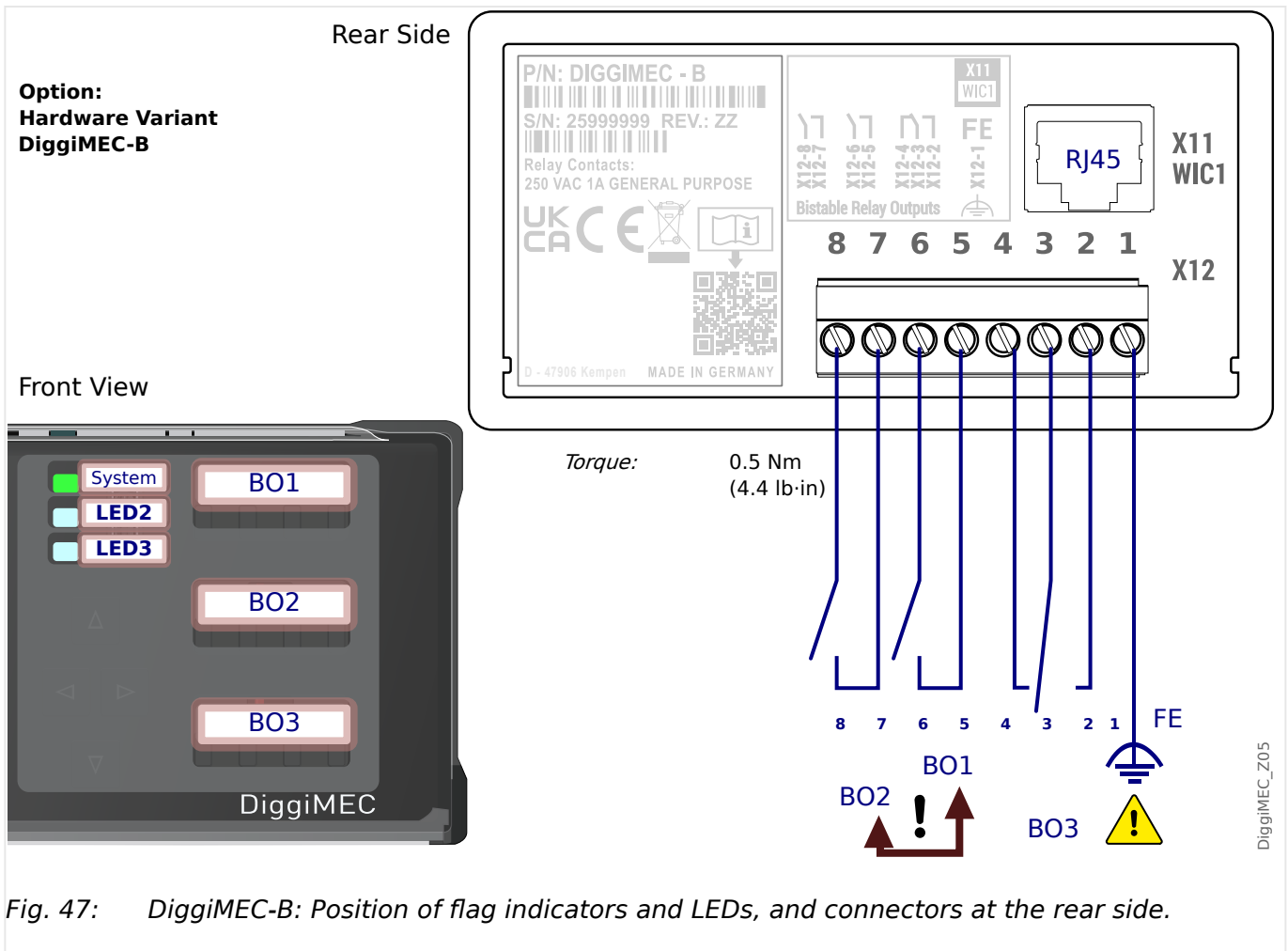



Fig. 47: DigiMEC-B: Position of flag indicators and LEDs, and connectors at the rear side.

Slot	Max. Torques of the Screws	Screw type	Description
X12	0.5 Nm (4.4 lb·in)	M3 slotted	Connections for functional earth and relay outputs
X11	—	—	RJ45 connection to the WIC1. Ethernet CAT3 cable or better, but beware, this is not an Ethernet connection! Crossover cables must not be used!

Functional Earth (“FE”)

The DigiMEC must be grounded:

WARNING!

 A ground connection (functional earth, min. 2.5 mm² [≲ AWG 13], tightening torque 0.5 Nm [4.4 lb·in]) must be connected at the “FE” terminal, see diagram ↪Fig. 47).

In general, all grounding connections must be low-inductance, i. e. as short as possible, and national standards – if applicable – must be followed.

RJ45

The DiggiMEC features an RJ45 connector on the rear side. Use a standard network cable (CAT 3 or better) to connect the DiggiMEC to the DiggiMEC-RJ45-connector of a WIC1.

NOTICE!

Although the communication between DiggiMEC and WIC1 is transferred over a network cable, note that this is not an Ethernet communication. In fact, a proprietary protocol is used.

Some WIC1 variants feature another RJ45 connector, that can be used for Ethernet-based communication, in particular TCP/IP-based SCADA protocols. This Ethernet-RJ45 connector must **not** be used for a direct connection with a DiggiMEC.

Relay Outputs

The “Outputs” terminals feature:

- For device variants DiggiMEC-**A**, one normally-open (Form A) relay contact, that is mechanically connected with a flag indicator.
(Note that this contact is labeled as BO2 within the WIC1 configuration.)
- For device variants DiggiMEC-**B**, one changeover (Form C) and two normally-open (Form A) relay contacts. Each of these three relay outputs is mechanically connected with one of the three flag indicators.

All relay contacts are bistable and potential-free. They can be triggered by a digital signal from the WIC1. Since each relay is mechanically connected to a flag indicator, switching a relay means that the corresponding flag indicator starts to show its signal, and vice versa.

Further details, in particular about the settings at the WIC1, are here: [↪3.13.3 Flag Indicator / Output Relays Settings \(DiggiMEC\)](#)

WARNING!

The bistable output relays of a DiggiMEC, that is connected to the WIC1, may be used only for visualization purposes. It is not permitted to use these relay contacts for any protection-related and/or switching purposes!

If the DiggiMEC relays are used for switching purposes there is the risk of an unreliable protection of your application!

Only the trip-coil output “TC+/-” of the WIC1 may be used for tripping a breaker.

Remarks with respect to this warning

- The switching time of the “TC+/-” output is faster than that of a DiggiMEC output relay. Therefore it is strongly discouraged to use a DiggiMEC output relay for any protection-related switching purposes.
- It is possible to assign the WIC1 signal »Prot . TripCmd« to a DiggiMEC output relay. This is absolutely o.k. for visualization purposes. But there is no signaling back of a DiggiMEC relay status to the WIC1. This has the consequence that the WIC1 cannot realize any signaling/switching problem if – for instance – there is no DiggiMEC connected to the WIC1, or if there should be any technical problem with the DiggiMEC. In such a case the whole protection concept can be void.

- It is technically possible and permitted to switch the relay contact manually. But if a breaker should be connected directly to a DiggiMEC output relay, it would be opened by such a manual switching, and the WIC1 would not be able to detect this. This makes the whole protection concept unsafe and not permissible.
- The WIC1 Backup Protection cannot switch a DiggiMEC output relay. It only uses the "TC+/-" output.

3.13.3 Flag Indicator / Output Relays Settings (DiggiMEC)

Depending on the [ordered type](#), the device features either one flag indicator FI2 (DiggiMEC-A), or three flag indicators FI1, FI2, FI3 (DiggiMEC-B).

See also [↔3.13.2 DiggiMEC Connectors](#).

Each of these flag indicators is mechanically coupled with a bistable output relay.

WARNING!



The bistable output relays of a DiggiMEC, that is connected to the WIC1, may be used only for visualization purposes. It is not permitted to use these relay contacts for any protection-related and/or switching purposes!

If the DiggiMEC relays are used for switching purposes there is the risk of an unreliable protection of your application!

Only the trip-coil output "TC+/-" of the WIC1 may be used for tripping a breaker.

At any time, the WIC1 can toggle the state of an Flx. Note that each Flx is always only set with the rising edge of the assigned signal.

With respect to the DiggiMEC flag indicators, there is the following convention: In the state appearing as a red-colored mark at the DiggiMEC front the flag indicator / output relay has been "set", and the other state means that the Flx has been "reset".

WARNING!



A CT-powered WIC1 is able to reliably set and reset the flag indicators only under the condition that it is supplied with sufficient electrical energy via the CTs.

CAUTION!



It is not possible for the WIC1 to check the current state of any Flx. So, if the user mechanically changes the state of an Flx the new state is not signaled to the WIC1.

In other words: Although it is possible at any time to change the state of an Flx by hand, this should only be done with great care, being aware of potential consequences, because this also switches the state of the output relay contacts.

After a reset (via HMI or Digital Input), however, all Flx - regardless whether with or without latching - (re-)assume their correct states according to the current state of the assigned signals. (Important: The reset is functional only if the WIC1 settings have specified which DiggiMEC variant is connected; the related parameter is [Device planning / WIC1 + DiggiMEC] »DiggiMEC . Mode«.)

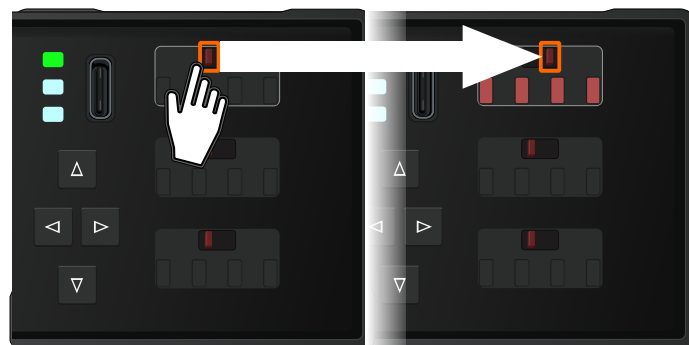

DiggiMEC_Z07

Fig. 48: Important: Manually toggling the state of a flag indicator also switches the contacts of the respective output relay.

The conditions of a module output or signal of a protective function can be assigned to an Flx, so that it is both electrically available (via the relay contacts) and visualized (via the flag indicator). Since the Flx are bistable the last state remains available even after the WIC1 and DiggiMEC are no longer supplied (i. e. have been switched off).

All output relay contacts are potential-free. Each relay can be assigned a signal out of the »assignment list«.

NOTICE!



Whenever the DiggiMEC is not actively used by a human operator we recommend to keep the lid closed. (Depending on the local security directives you might also want to use the sealing option.)

This prevents an unintended re-positioning of the flag indicators / output relays. Furthermore, it reduces the risk of dust or dirt intruding into the mechanics of the flag indicators.

Within menu branch [Device Para / DiggiMEC / FI / BO], set the following parameters for each Flx:

- »Assigned signal«: The parameter »Flx assign.« assigns a trigger signal to Flx.
- With the setting »Flx latching« = “No latching”, the Flx continuously adopts the state of the assigned signal.
- If »Flx latching« is set to “With latching” or to “Latch. w. Auto-Reset”, the state that is set by the trigger signal is permanently stored. (For details see [↪3.13.3.1 Latching.](#))

Each Flx can only be reset - “acknowledged” - after the signal that had initiated its setting has dropped out.

3.13.3.1 Latching

After the assigned signal has become active a latched Flx keeps its state until it is acknowledged, or some automatic reset occurs.

A latched Flx gets reset only in any of the following cases and only after the assigned trigger signal has dropped out.

The following latching modes are settable via [Device Para / DiggiMEC / FI / BO] »Flx latching«:

- “No latching” – The status of the flag indicator immediately follows the status of the assigned signal.
- “With latching” – When the assigned signal gets active it sets the flag indicator, which stays set. After the assigned signal has dropped off the flag indicator can be electrically reset by the device.
- “Latch. w. Auto-Reset” – latching with automatic reset, see also [↪2.11.1 Automatic Reset](#).

3.13.3.2 Testing the Flag Indicators / Output Relays

The correct functioning of the flag indicators can be verified by the steps following below.

Please consider that the test requires switching the flag indicators, which also changes the electrical state of the relay contacts. Therefore you should only carry out the test if this is acceptable.

After the test has been carried out successfully each flag indicator / output relay is reset to the state of the assigned signal.

Verify that the Flx Show the Correct State:

- | | |
|------|---------------------------------------------------------------------------------------------------------------------------------------------------------------------------------------|
| ⚙ | |
| 1. ▷ | Execute a reset command, [Operation / Reset] »Rst. LEDs, Fls«. |
| 2. ▷ | <ul style="list-style-type: none"> • The assignments are shown at [Device Para / DiggiMEC / FI / BO]. • The states are shown at [Operation / Status Display]. |
| ▶ | The assigned states and the flag indicators must be matching each other. |

Verify that the Flx Can Change Their State:

- | | |
|------|--------------------------------------------------------------------------------------------|
| ⚙ | |
| 1. ▷ | Verify that the current Flx states are correct, as described above. |
| 2. ▷ | Then toggle the Flx to the opposite state manually, as shown in ↪Fig. 48 . |
| 3. ▷ | Finally execute a reset command (again), [Operation / Reset] »Rst. LEDs, Fls«. |
| ▶ | The Flx must return back to their correct / verified state. |

3.13.4 Default Setting LEDs & Flag Indicators / Output Relays

By default the WIC1 is pre-configured for a DiggiMEC. Therefore, the [LEDs](#) and [flag indicators / output relays](#) of the DiggiMECs can be used in a default configuration even in combination with DIP- or HEX-switch parametrization (WIC1-2, WIC1-3). If no DiggiMEC is connected, this has no effect on the WIC1.

The number of available flag indicators / output relays depends on the [DiggiMEC variant](#).

LEDs

Name	Value
»LED2 assign.«	"TCM . Alarm"
»LED3 assign.«	"Prot . Trip"
»LED2 Color«	"Red"
»LED3 Color«	"Red"
»LED2 latching«	"With latching"
»LED3 latching«	"Latch. w. Auto-Reset"

Table 1: DiggiMEC LED default parameter setting under [Device Para / DiggiMEC / LEDs]

Flag Indicators / Output Relays

Name	Value
»FI / BO 1 assign.«	"Prot . Trip IPh"
»FI / BO 2 assign.«	"Prot . TripCmd"
»FI / BO 3 assign.«	"Prot . Trip IG"
»FI / BO 1 latching«	"Latch. w. Auto-Reset"
»FI / BO 2 latching«	"Latch. w. Auto-Reset"
»FI / BO 3 latching«	"Latch. w. Auto-Reset"

Table 2: DiggiMEC FI / BO default parameter setting under [Device Para / DiggiMEC / FI / BO]

4 Communication Protocols (WIC1-4 only)

NOTICE!



SCADA communication is supported only by an externally supplied WIC1-4. (In principle, it is possible to operate a WIC1-4 only with supply via the CTs, i. e. without auxiliary supply, but then no SCADA communication is available.)

After two consecutive device-internal errors, the WIC1 has entered a special “Protection-Only” operating mode (see ↪“The »System« LED(s) - “Ready”, “Error””), and after another device-internal error, only the Backup Protection gets started (see ↪7.3.1 [Activation of the Backup Protection / Self-Supervision Mode](#)). In these both operating modes, there is **no** SCADA communication (nor any communication with Smart view (PC) / DiggiMEC).

4.1 TCP/IP Settings

NOTICE!



TCP/IP connections are available only if your device is equipped with an Ethernet Interface (either RJ45, ↪[3.8 Ethernet Interface \(RJ45\)](#), or fiber optics LC, ↪[3.9 Ethernet / TCP/IP via Fiber Optics](#)).

Contact your IT administrator in order to establish the network connection.

Within menu [Device Para / TCP/IP / TCP/IP config] the TCP/IP settings have to be set:

- »*IP address*«, part 1 ... 4 - the IPv4 address^(*) of the WIC1.
- »*Subnet mask*«, part 1 ... 4 - the subnet mask^(*) that defines the IP address range of your local network.
- »*Default gateway*«, part 1 ... 4 - the default gateway^(*): This address is contacted for all connections to IP addresses outside your local network (i. e. for IP addresses not matching the range of the subnet mask).

Before the settings can be changed, the TCP/IP communication must be manually deactivated via [Device Para / TCP/IP / TCP/IP config / Function]. Afterwards, it must be re-activated.

(*) Each IP-address and the subnet mask needs to be entered as four separate numbers.

4.2 Modbus® (WIC1-4 only)

The Modbus® communication protocol is available with WIC1-4 devices that are supplied by auxiliary power and are equipped with a serial interface (“Modbus RTU”), see [↔3.7 Serial Interface RS485 \(WIC1-4... only\)](#) or an Ethernet interface (“Modbus TCP”, either [RJ45](#) or [fiber optic](#)).

As a Modbus RTU Slave, the WIC1-4 can serve exactly one Modbus RTU Master (i. e. the substation control and protection system).

As a Modbus TCP Server, the WIC1-4 can serve max. 2 Modbus TCP Clients. If a third client tries to connect while there are already two established TCP connections then this third attempt will not get acknowledged.

Read parameters: The WIC1-4 supports this feature for both Modbus RTU and TCP.

NOTICE!



Ethernet-related software modules, in particular »TCP/IP« and »Modbus TCP«, are carried out by a co-processor, i. e. a second CPU. This unburdens the main CPU and thus stabilizes all protection functionality. Even in the extreme case that the TCP/IP communication should crash, would all protection modules continue with full functionality.

For the Modbus TCP communication, however, this recommends that the user keeps in mind the times described in [↔“Cycle Times with Modbus TCP and RTU”](#).

Modbus® Protocol Configuration

The standard protocol definition (mapping of data-points) that comes with the WIC1 is sufficient for most applications, so that only a few settings have to be made (see below).

The time-controlled Modbus® protocol is based on a Master-Slave (or Client-Server) working principle. This means that the substation control and protection system (the Modbus RTU Master, or Modbus TCP Client) sends an enquiry or instruction to a certain device (Modbus RTU Slave, or Modbus TCP Server), which will then be answered or carried out accordingly. If the enquiry/instruction cannot be answered/carried out (e. g. because of an invalid slave address), a failure message is returned to the master.

NOTICE!



Some signals (that are for a short time active only) have to be acknowledged separately (e.g. Trip signals) by the Communication System.

The Master (substation control and protection system) can query information from the WIC1-4 and give commands. For detailed information on data point lists and error handling, please refer to the Modbus® documentation. Moreover, there is a WIC1 Modbus Specification document, and the datapoints are listed in Microsoft Excel® format.

Setup

First, the Modbus protocol has to be activated via the setting [[Device planning / Projected Elements]] »*Modbus . Mode*«:

- = “RTU” — use the Modbus® protocol over a serial connection. This setting is available only for device variants with [RS485 interface](#).
- = “TCP” — use the Modbus® protocol over Ethernet (TCP/IP). This setting is available only for device variants with Ethernet interface (either [RJ45](#) or [optical](#)).

Then continue with the settings described below for Modbus RTU or Modbus TCP, depending on your type of use.

Modbus RTU

Part 1: Configuration of the Devices

Enter the menu [Device Para / Modbus / Communication / RTU] and set the communication parameters there. (See see Reference Manual.)

Also, select some RS485 interface-related parameters from there, see Reference Manual.

Part 2: Hardware Connection

- For hardware connection to the control system, see [↔3.7 Serial Interface RS485 \(WIC1-4... only\)](#).
- Connect bus and device (wiring).

Information on physical communication data and errors are available from dedicated diagnosis counters, see Reference Manual.

Modbus TCP

NOTICE!



Establishing a connection via TCP/IP to the device is only possible if your device is equipped with an Ethernet Interface ([RJ45](#) or [fiber optics](#)).

Contact your IT administrator in order to establish the network connection.

Part 1: Setting the TCP/IP Parameters

Call up [Device Para / TCP/IP / TCP/IP config] at the HMI (panel) and set the following parameters:

- TCP/IP address
- Subnet mask
- Gateway

Part 2: Configuration of the Devices

Call up »Device parameter/Modbus« and set the following communication parameters:

- Set the port-number if a different port than the default port 502 should be used.

Part 3: Hardware Connection

- Use the Ethernet interface ([RJ45](#) or [fiber optics](#)) for the hardware connection to the control system.
- Establish the connection to the device by means of a proper (Ethernet or fiber) cable.

Cycle Times with Modbus TCP and RTU

The internal communication between main CPU (i. e. the protective unit) and the [co-processor](#) is carried out in defined refresh rates, and it is good to know these when planning the SCADA communication:

- All measurement values and logical states are transferred to the co-processor (approx.) once per second. This means that it makes no sense to request a particular Modbus address more often than once per second, because this will only increase the Ethernet traffic without transmitting any new values.
- For a transmitted Modbus command it can take up to max. 150 ms until the command gets executed by the main CPU (i. e. the protective unit).

5 Protective Elements

5.1 »Prot« - General Protection Module

The module “General Protection” (»Prot«) serves as outer frame for all other protection modules, i. e. a master module that is connected to all protection stages.

Definition (“Alarm ↔ Trip”) of a Protection Function

It is possible for every protection stage to define during the commissioning setup whether this stage shall issue a trip signal in case of a fault, so that the circuit breaker gets opened, or whether the stage shall simply issue an alarm signal, without tripping. This setting can be done within the menu [Device planning]. This menu branch features a setting parameter »Definition« for each protection stage.

- In general, a fault leads to a pickup of the respective protection stage. If the stage is not blocked the signal »Pickup« is issued, and this is also (internally) reported to the master module »Prot«.

The further operation depends on the category of the protection stage:

- »Definition« = “Alarm” — **The protection stage operates as a pure supervision function**, this means:

- A protection pickup does not issue a General Pickup »Prot . Pickup«. Instead, if the fault persists after a settable timer has elapsed (see ↪Fig. 49), an alarm signal »Alarm« is issued, which is also (internally) reported to the master module »Prot«.
- The master module »Prot« then issues a General Alarm, this is the signal »Prot . Alarm«.

If the protection stage is phase-selective then also the respective signals »Alarm IA«, »Alarm IB«, »Alarm IC« are issued. (These signals, however, are **not** reported to the »Prot« module. But just like every signal, these can be directly viewed within the respective menu branch.)

- »Definition« = “Trip” — **The protection stage operates as a “full” protection stage and is able to trip the circuit breaker:**

- The master module »Prot« then issues a General Pickup. The respective signal is labeled »Prot . Pickup«.

If the pickup comes from a phase current protection stage the additional signal »Prot . Pickup I Ph« is issued.

If the pickup comes from a ground (earth) current protection stage the additional signal »Prot . Pickup IG« is issued.

If the pickup comes from a phase-selective protection stage then the faulty phase(s) can be seen from the additional respective signal(s) »Prot . Pickup IA«, »Prot . Pickup IB«, and/or »Prot . Pickup IC«.

- If the fault persists after a settable timer has elapsed – see also ↪Fig. 49:

A trip signal »Trip« is issued, which is also (internally) reported to the master module »Prot«.

- The master module »Prot« then issues a General Trip, this is the signal »Prot . Trip«.

If the protection stage is phase-selective then also the respective signals »Trip IA«, »Trip IB«, »Trip IC« are issued and (internally) reported to the master module »Prot«.

- In this case the master module »Prot« also issues the respective phase-selective »Prot . Trip IA«, »Prot . Trip IB«, »Prot . Trip IC«.
- Finally the master module »Prot« generates a trip command, the signal is »Prot . TripCmd«.

Along with a trip command, a sequence of trip impulses is generated, that are output as voltage pulses at the trip terminal of the WIC1. With correct wiring, these pulses trigger the circuit breaker to be opened.

If a DigiMEC is connected, a pop-up window is sent onto the display in order to draw the user's attention to the fault. (See [↔6.1 Fault/Alarm Display](#).) This might be helpful for fast fault analysis.

NOTICE!



After the circuit breaker has tripped, a CT-powered WIC1 variant is switched off, because it is obviously no longer supplied via any CT current. The fault event, however, is recorded in a non-volatile memory and can be read (after the next WIC1 startup). See also [↔6 Fault/Alarm Recorder](#).

5.1.1 General Pickup, General Alarm, General Trip

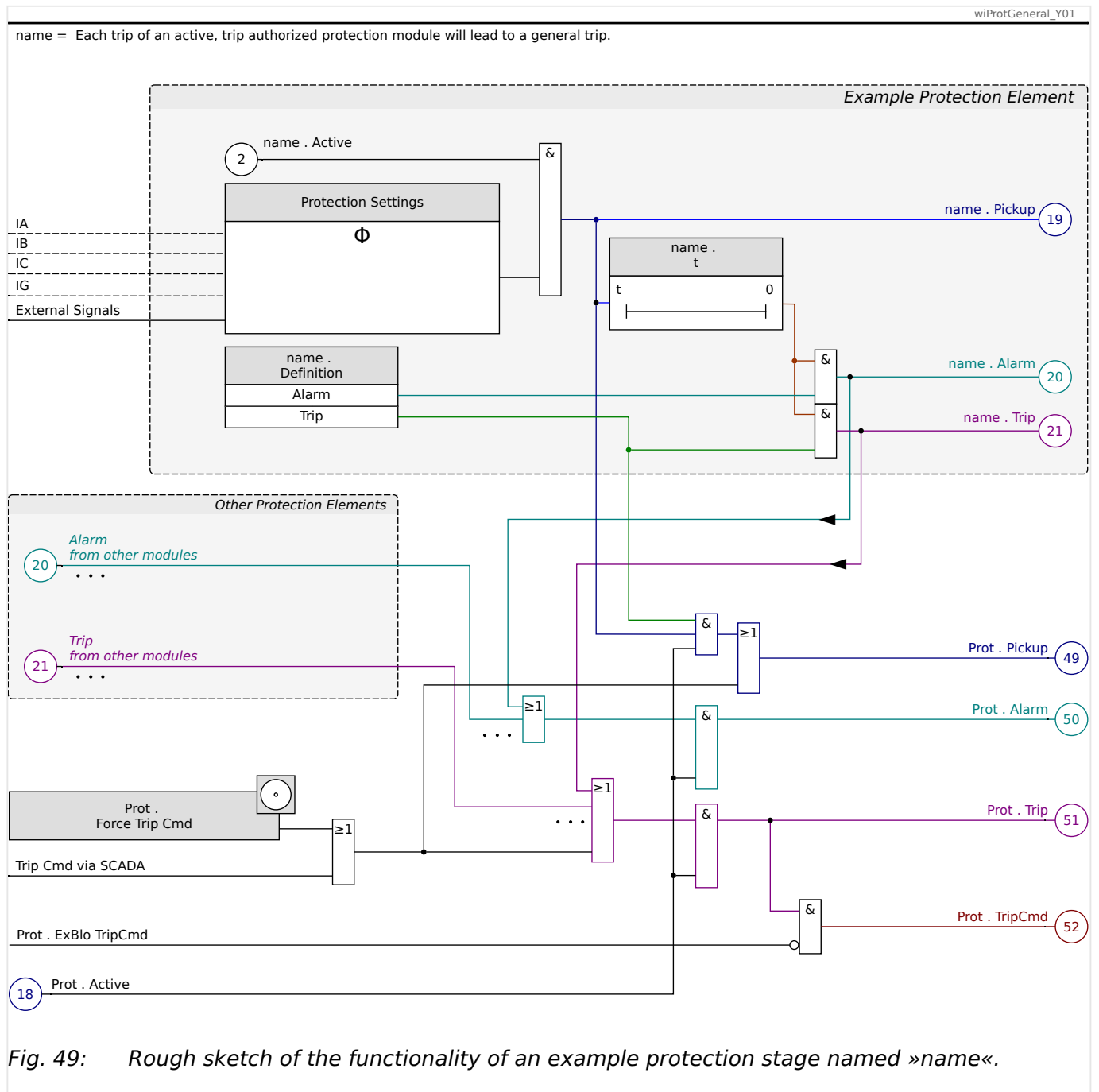

The diagram visualizes the protection signals of any WIC1 protection stage, »name«, and how these are reported to the »Prot« master module. However, the phase-specific signals and the collective signals »Prot . Pickup I Ph« and »Prot . Pickup IG« have been omitted to make the concept better understandable.

5.1.1.1 Trip Pulse and WIC1 LEDs

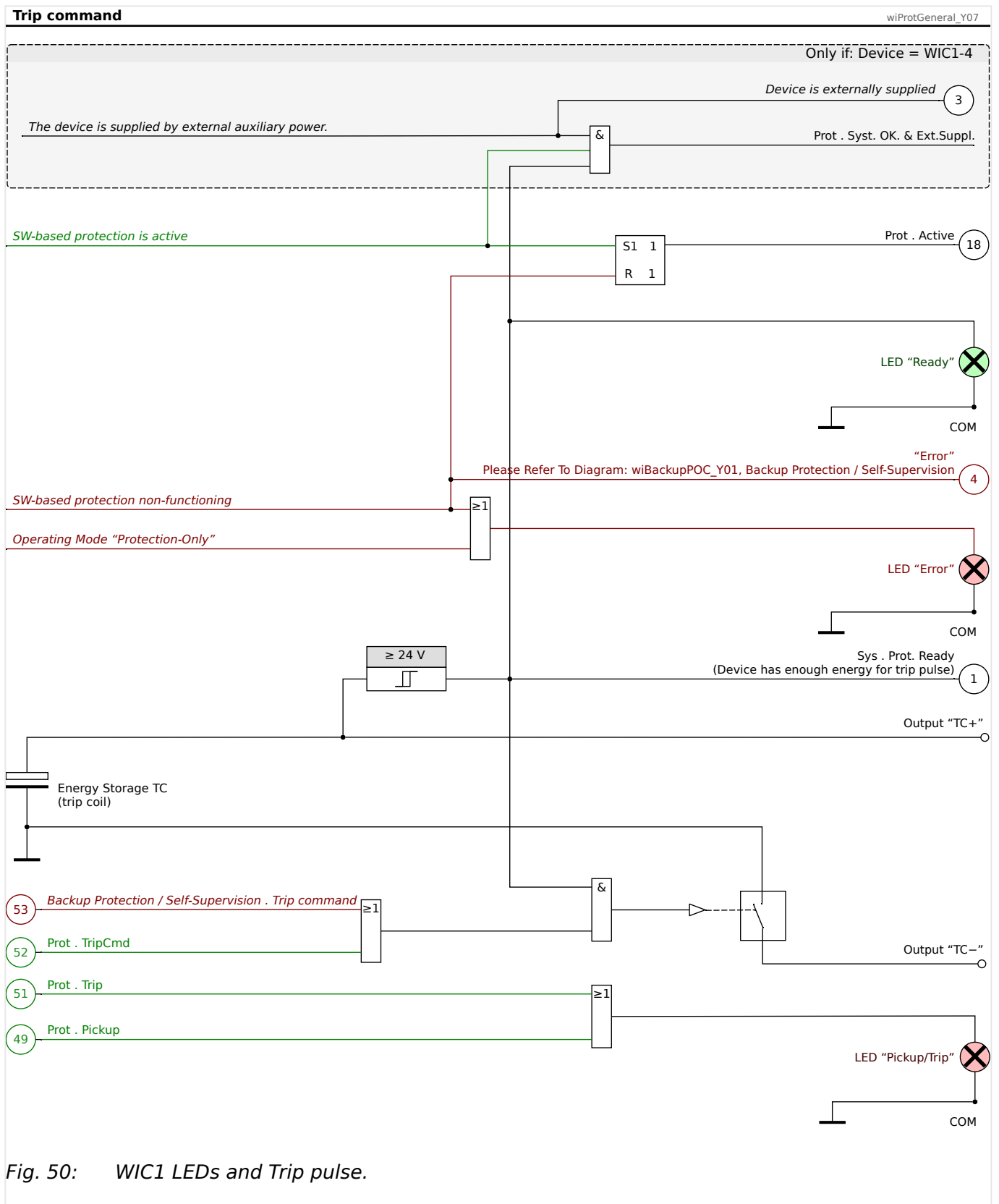

Fig. 50: WIC1 LEDs and Trip pulse.

Note that the trip pulse is output like shown in the diagram, by connecting the "TC-" contact internally with COM. A detailed description of the WIC1 LEDs can be found in [3.11 LEDs](#).

The signals and line connections in dark red color can be active only if the Self-Supervision of the WIC1 has determined an internal problem. The signals and line connections in green color can be active only if the software-based protection functions are all healthy.

The signal »Prot . Active« - labeled as number (18) in the diagram - gets active as soon as the WIC1 has started and activated the (software-based) protection modules. This is also true of the “Protection-Only” operating mode. But if the Self-Supervision has determined the software-based protection as non-functioning only the Backup Protection is running and **all** signals are inactive. (The latter fact is indicated in the diagram by inactivating (18) »Prot . Active« via the “R” Reset input of the S&H block. Of course, this is merely a makeshift: If the WIC1 software is not functioning there can be no correct visualization of the internal functionality.)

NOTICE!



A General Pickup signal makes the “Pickup/Trip” LED flashing red, and a General Trip signal makes the “Pickup/Trip” LED shine constantly red (as long as the WIC1 is still being supplied with power and the signal is active).

There is no latching of this LED. (See also ↪3.11 LEDs.)

5.1.1.2 Phase-Selective Signals, Collective Signals

In addition to the signals shown in the diagram [Fig. 49](#), the »Prot« module also features collective signals and phase-selective signals. The phase-selective signals can be issued by protection modules that are able to detect 1p faults.

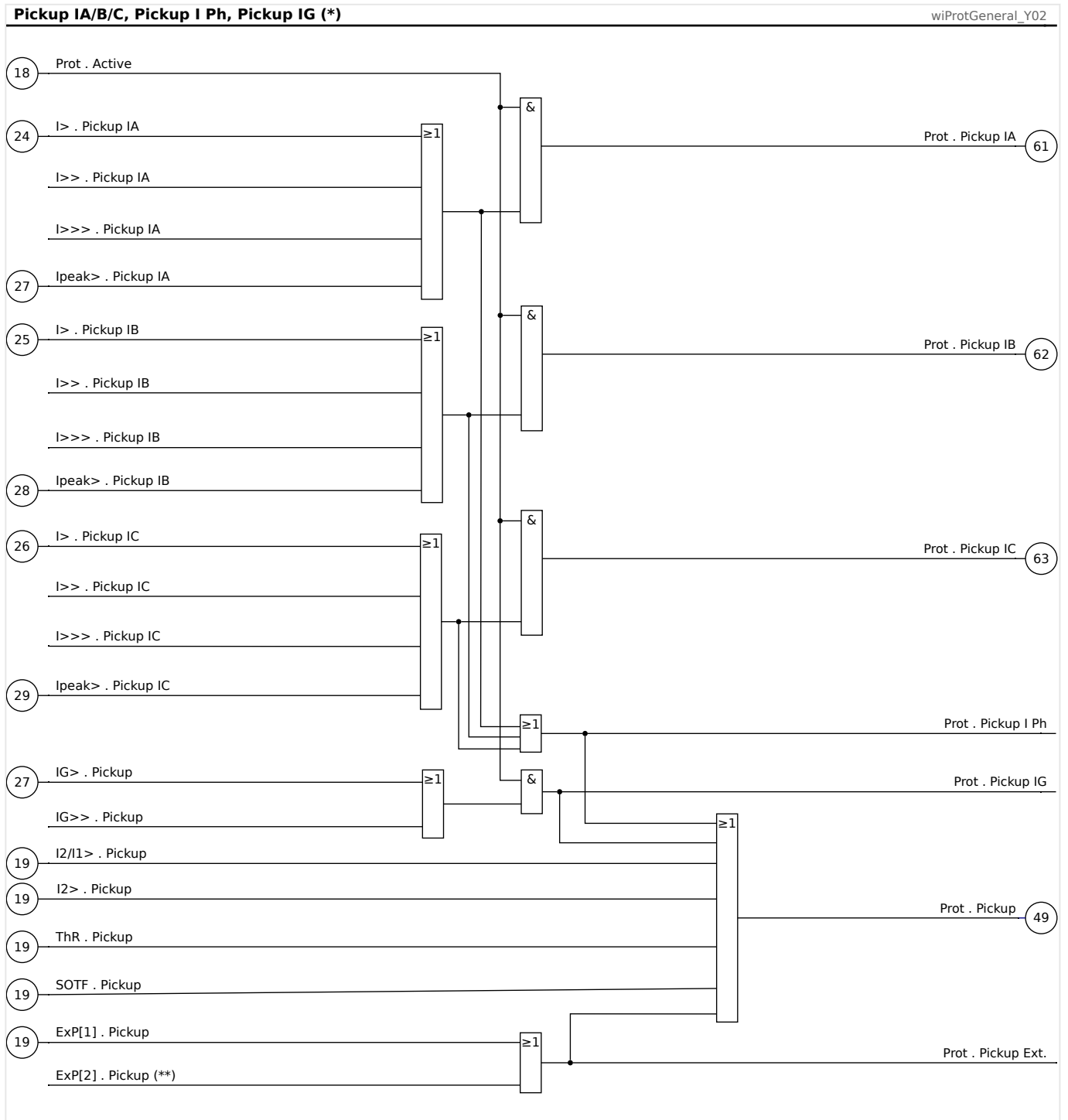

Fig. 51: Phase-selective General Pickup signals and the respective collective signals.

(*) All General Pickup signals, including the phase-selective ones, are issued only by protection functions that are set as »Definition« = "Trip". (See also ["Definition \("Alarm ↔ Trip"\) of a Protection Function"](#).) This is not shown explicitly in the diagram.

(**) A second »ExP« instance is available only on WIC1 variants with two Digital Inputs. (See [order options](#).)

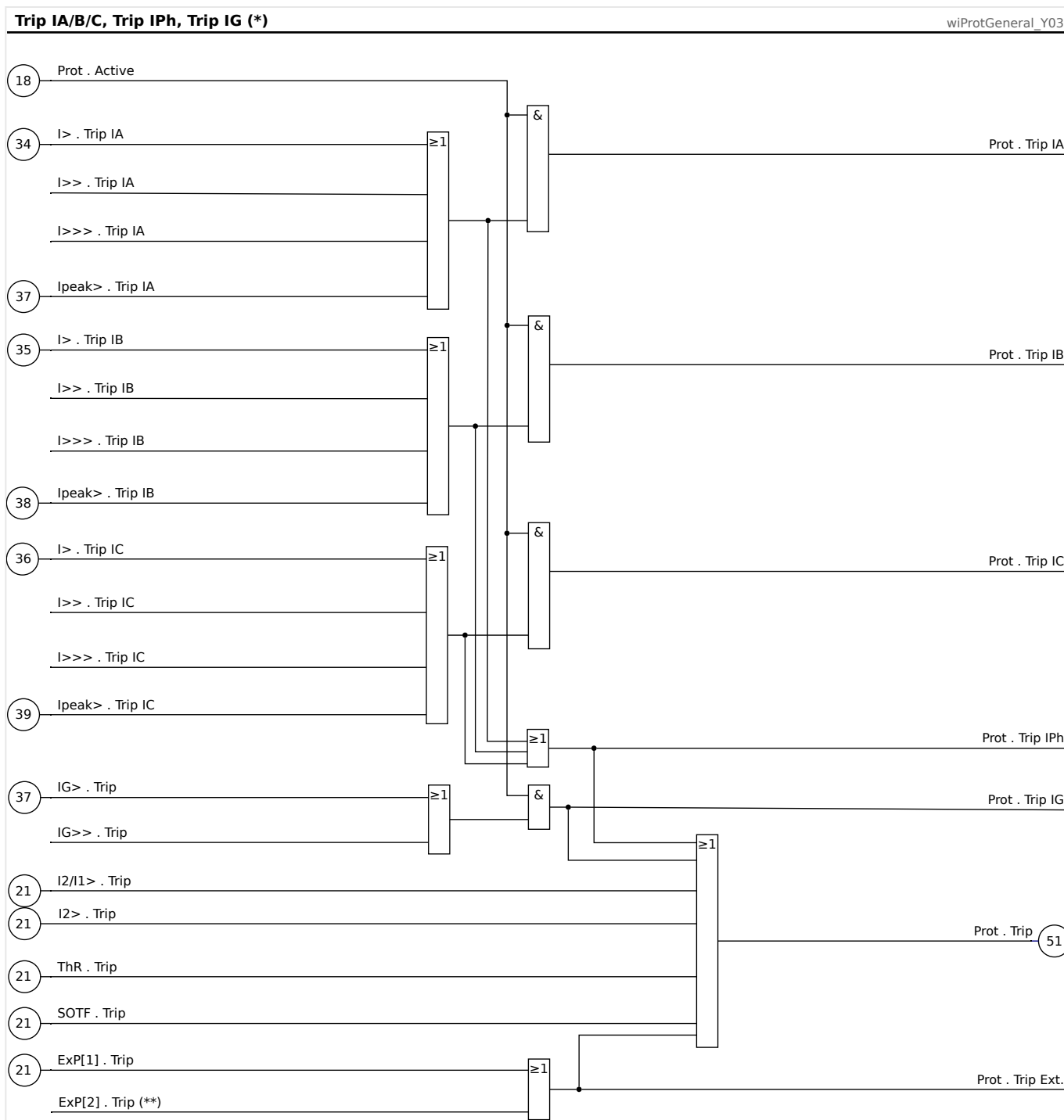

Fig. 52: Phase-selective General Trip signals and the respective collective signals.

(*) All trip signals, including the phase-selective ones, are issued only by protection functions that are set as »Definition« = "Trip". (See also ↔"Definition ("Alarm ↔ Trip") of a Protection Function".) This is not shown explicitly in the diagram.

(**) A second »ExP« instance is available only on WIC1 variants with two Digital Inputs. (See order options.)

5.1.2 Force Trip Command

For commissioning or testing purposes, the user can initiate a trip command manually via [Service / Prot] »Prot . Force Trip Cmd«.

See also the function diagram, ↪[Fig. 49](#).

But note that if the WIC1 is supplied only via USB then the voltage of the trip pulse might be too low to actually trigger the breaker. See also ↪[2.3 Supply of a WIC1](#) and "[Troubleshooting: System-LED is Off](#)".

5.1.3 Blockings

The device provides a function for blocking of the trip command. In addition, most of the protection stages can be blocked individually.

WARNING!



Make absolutely sure that no illogical or even life-threatening blockings are allocated.

Make sure that you do not carelessly deactivate protection functions which have to be available according to the protection concept.

5.1.3.1 Switching Protection Functions On or Off

Each of the modules can be switched on or off (permanently). This is achieved when the parameter »Function« is set to "Active" or "Inactive" in the respective module.

- First, in the menu [Device planning] there is for each protection stage a parameter »Mode«. It takes the protection stage completely out of operation (or sets it into operation).

Every protection stage that it not required by the protection concept should indeed be deactivated this way, because it then no longer uses any device-internal resources (CPU time, memory).

Furthermore, activating and deactivating of protection stages automatically takes into account all dependencies that might exist between different protection stages. And a deactivated protection stage disappears completely from all menu branches (with the sole exception of the setting »Mode«, that allows for (re-)activating the protection stage.

- In addition to this kind of de-/activation, there is for each protection stage a setting »Function«, that can be "Active" or "Inactive". The protection stage is kept operating also for »Function« = "Inactive", but it is not protecting, i. e. it is "switched off".

5.1.3.2 Temporary Blocking

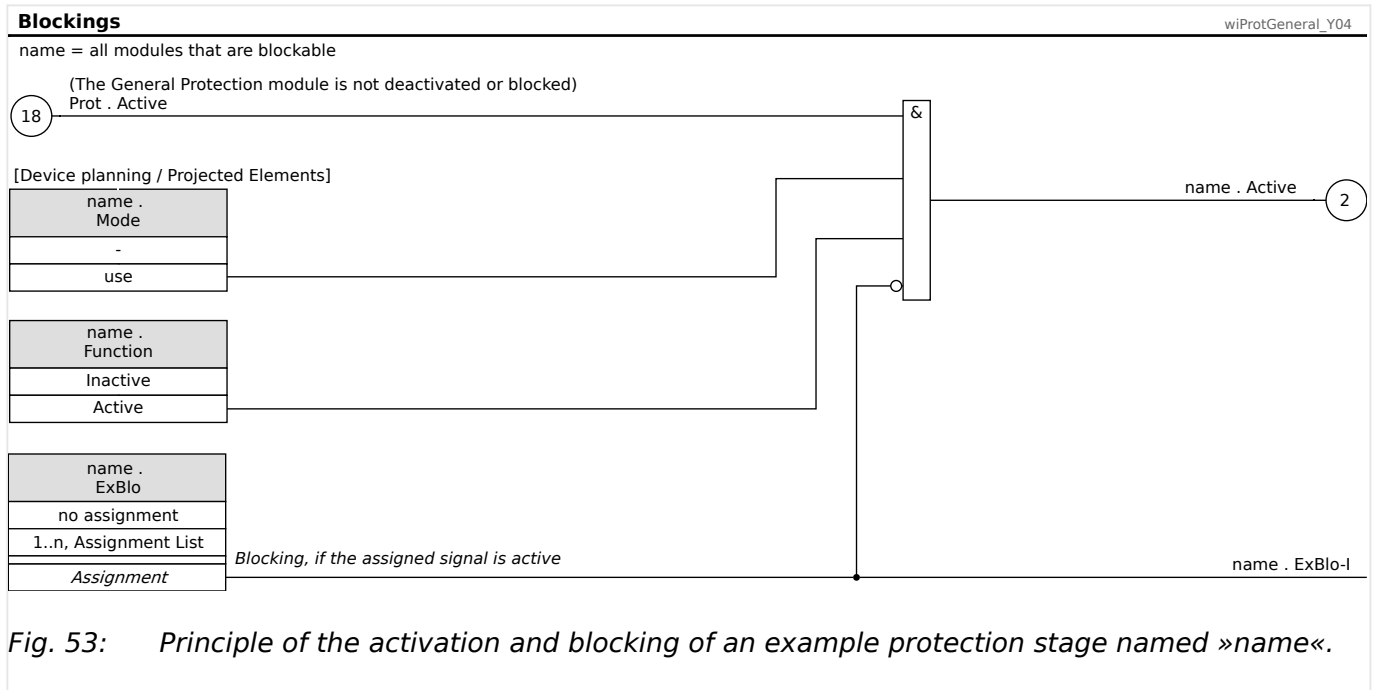

Fig. 53: Principle of the activation and blocking of an example protection stage named »name«.

To block a particular protection stage temporarily by an active signal:

- There is for each protection stage a setting »ExBlo«, to which a signal can be assigned. This signal can be selected from a list of device-internal and external signals. (“External signals” are those received from a Digital Input.) The blocking becomes active when the assigned signal is active.

5.1.4 Control of a Switchgear

The trip impulse output of the WIC1 (see →3.10 Outputs (Trip Coil, Flag Indicator, Relay Output)) needs to be connected to a switchgear that is responsible for clearing a fault that is detected by the WIC1. This is usually a circuit breaker, but depending on the particular application, other types of switchgear are in common.

DANGER!



Misconfiguration of switchgear could result in death or serious injury. This e. g. is the case when opening a disconnecter under load or when switching a ground connector to live parts of a system.

The commissioning engineer is responsible for the correct configuration and wiring of the switchgear, including documentation of all these aspects.

A correct configuration of all switchgear is an indispensable precondition for the proper functioning of the protective device.

5.1.4.1 Switch ON Command (external)

The WIC1 offers the possibility to assign an external (manual) Switch ON (or CLOSE) command to a digital input. The signal can then be used, for example, to activate the SOTF function when the breaker is closed.

Make sure your device is prepared to use Switch ON Command as this is only available for certain type codes with configurable inputs (see →2.6.1 Order Forms).

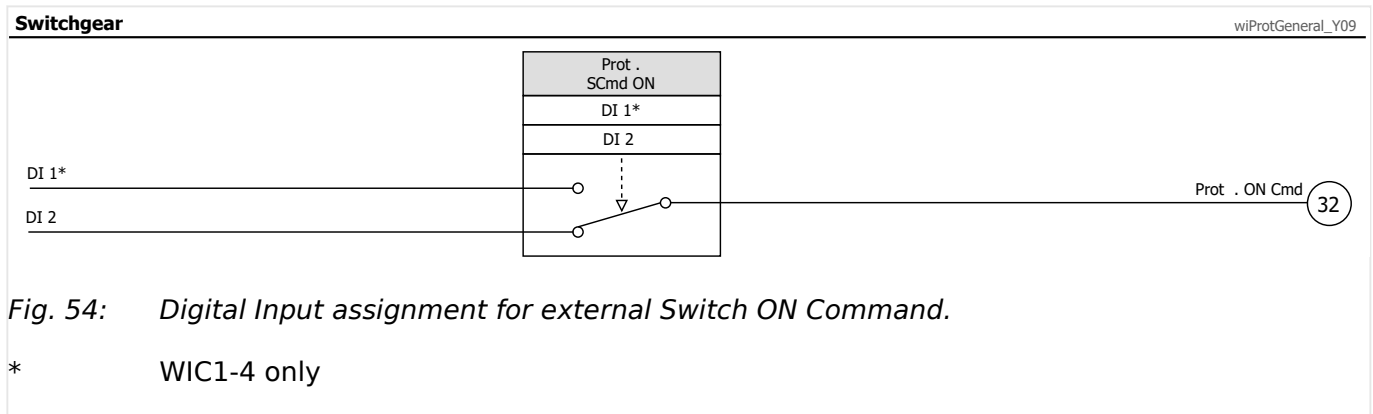

5.1.4.2 Switchgear Position

Criteria for Determining the Switchgear Position

The position indication is needed by the WIC1 to get (evaluate) the information about the current status /position of the breaker. This information is essential for the modules »Switch Onto Fault« (→5.10 SOTF - Switch Onto Fault) or the »Circuit Breaker Monitoring« (→5.13 CBF - Circuit Breaker Failure [50BF, 62BF]).

It is possible to select for the switchgear states CLOSE (“ON”) and OPEN (“OFF”), independent of each other, whether these states shall be detected based on phase currents or based on positioning indicator signals (or both). For WIC1 variants without configurable Digital Inputs, of course, only the current-based detection is applicable.

- Setting of the detection criterion for the CLOSE (“ON”) and OPEN (“OFF”) states:

[Protection Para / Breaker & Trip] »Meth.Detect.Bkr.Pos.« =

Options:

- “Aux-Based” — Signal-based detection.

(This option is available only with a WIC1-4 featuring configurable Digital Inputs.)

- “Current-Based” — Current-based detection.
- “Current and Aux” — Both criteria are used.

(Of course, this option, too, is available only with a WIC1-4 featuring configurable Digital Inputs.)

Wiring (only WIC1-4 with configurable Digital Inputs)

In case the position indication is based on signal inputs (↔“[Wiring \(only WIC1-4 with configurable Digital Inputs\)](#)”), the particular signals have to be assigned:

- The signal for the switchgear state CLOSE (“ON”) – if wired/required – can be assigned to:

[Protection Para / Breaker & Trip] »Aux ON«

You typically assign one of the two Digital Inputs here.

- For the signal for the switchgear state OPEN (“OFF”) – if wired/required – the same assignments are available:

[Protection Para / Breaker & Trip] »Aux OFF«

You can connect one of the position indicators' contacts (either the »Aux ON« or the »Aux OFF«), so that you still have the other Digital Input available. However, for some applications it can also be recommended to connect both position indicators.

Thereafter the trip coil output has to be connected with the switchgear.

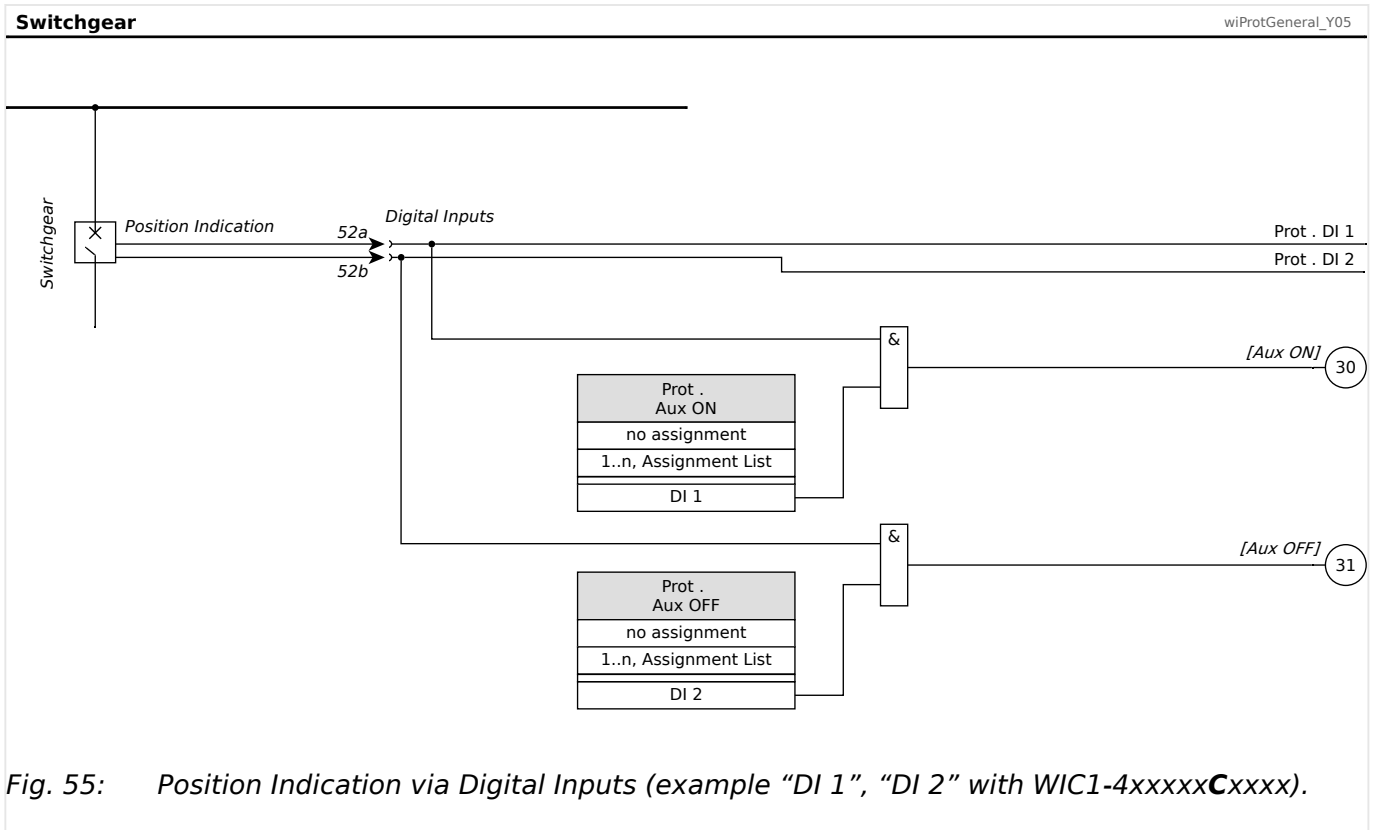

Position Indication, Part 1: Current-Based

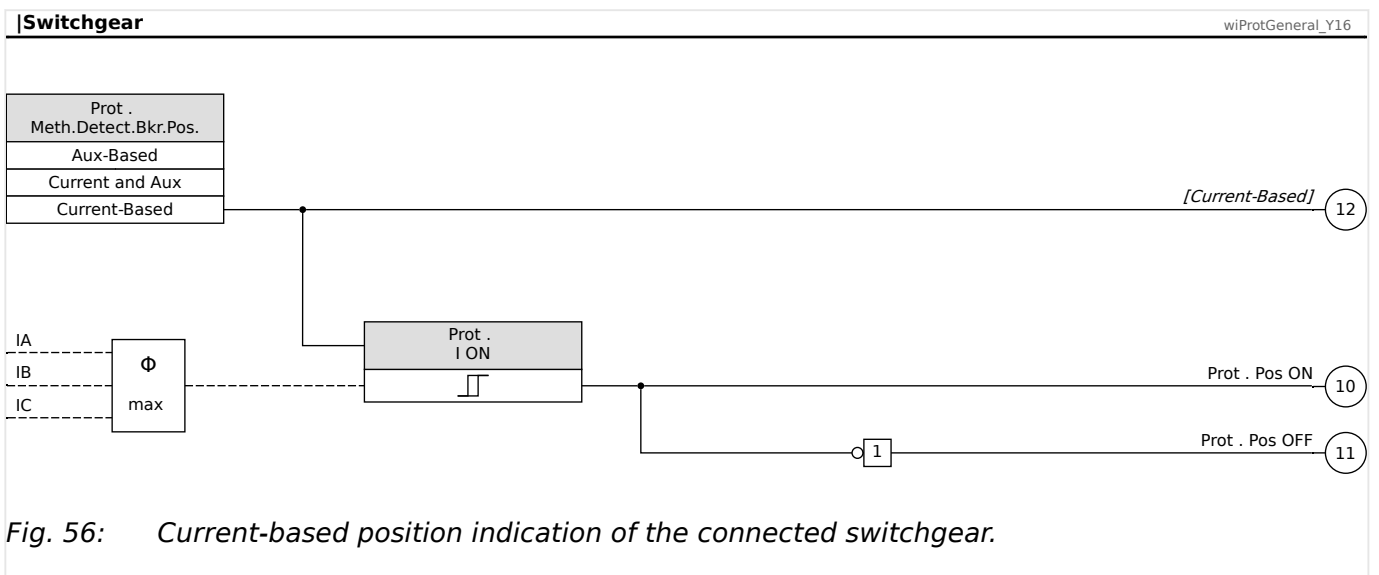

Position Indication, Part 2: One Contact

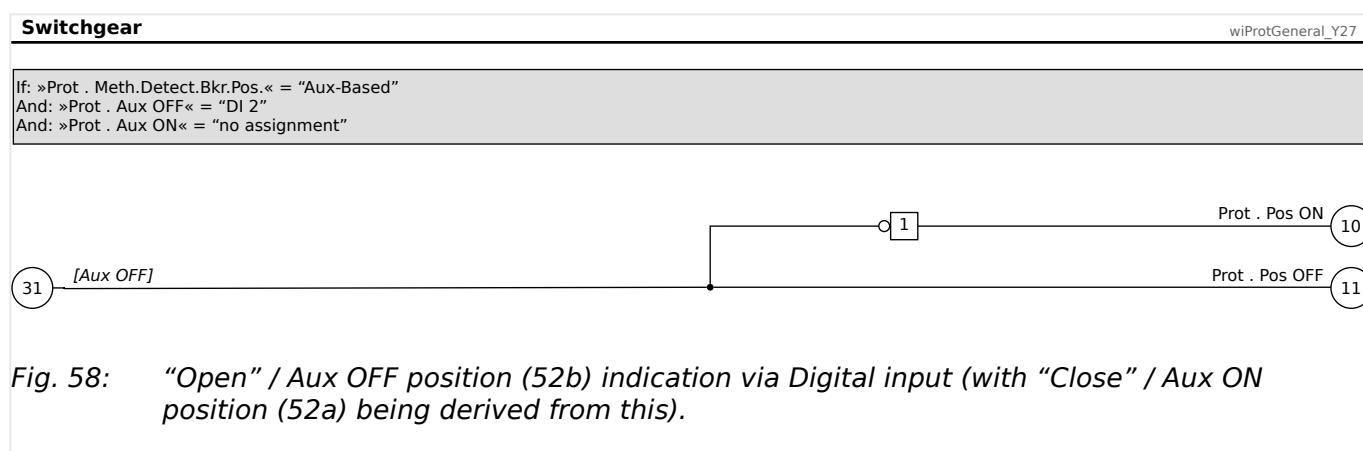
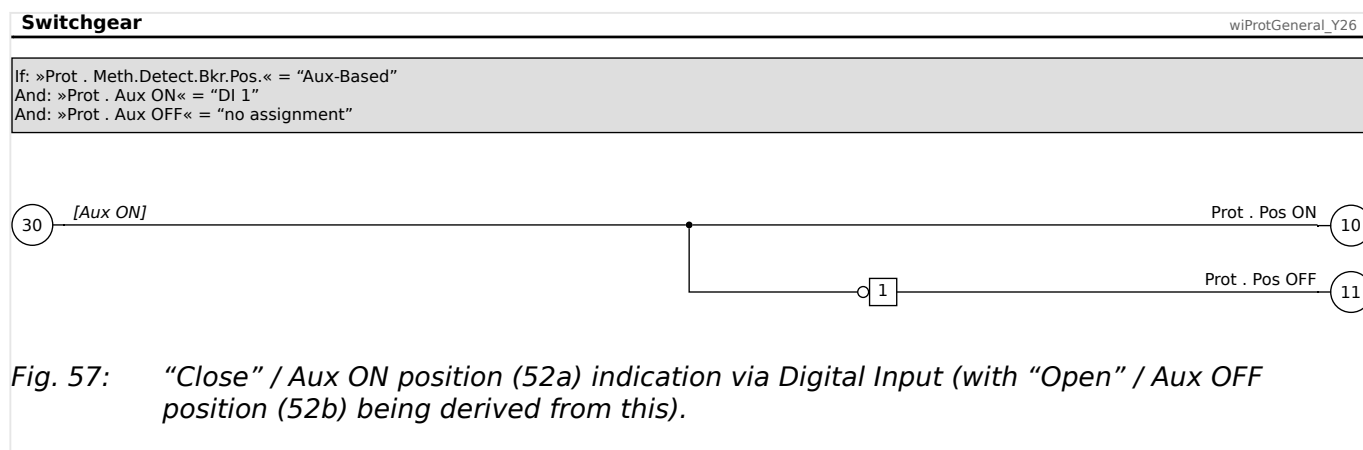

Position Indication, Part 3: Current-Based and One Contact

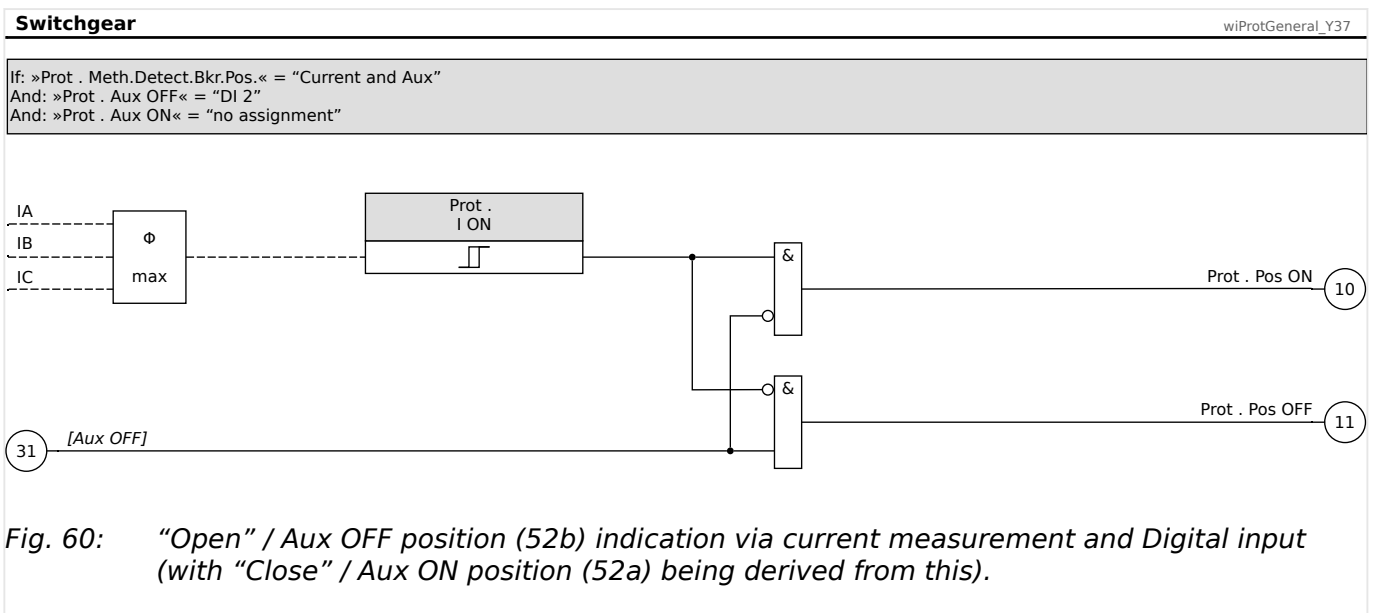
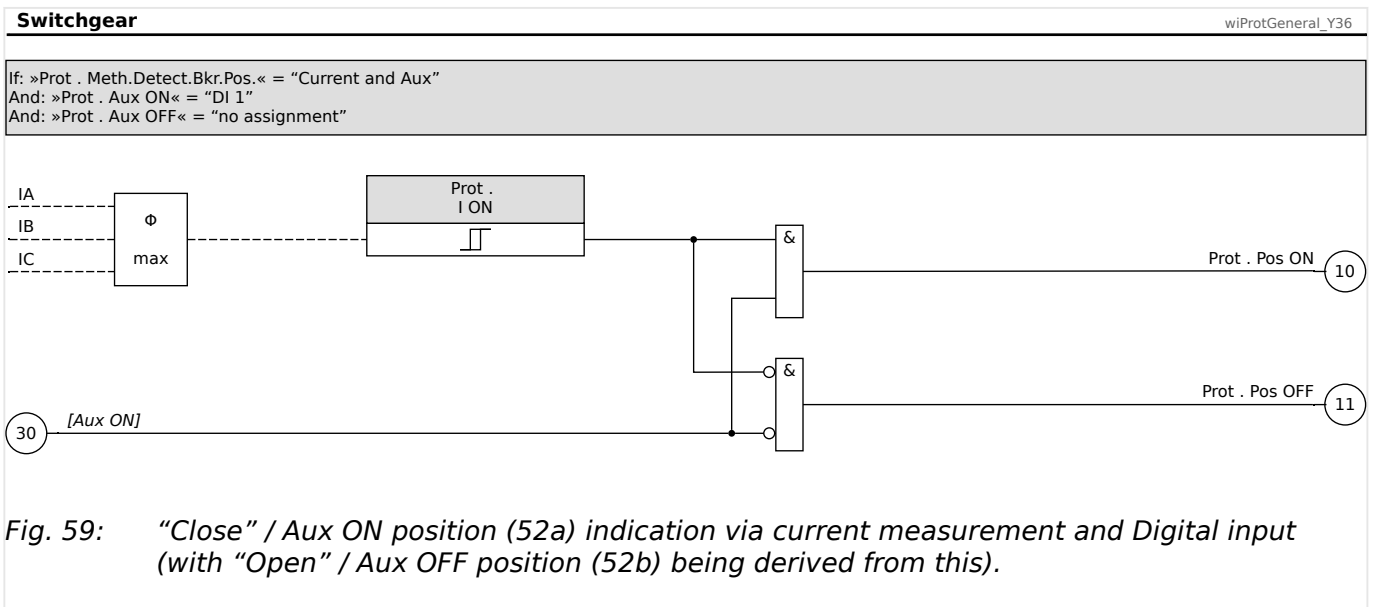

Position Indication, Part 4: Two Contacts

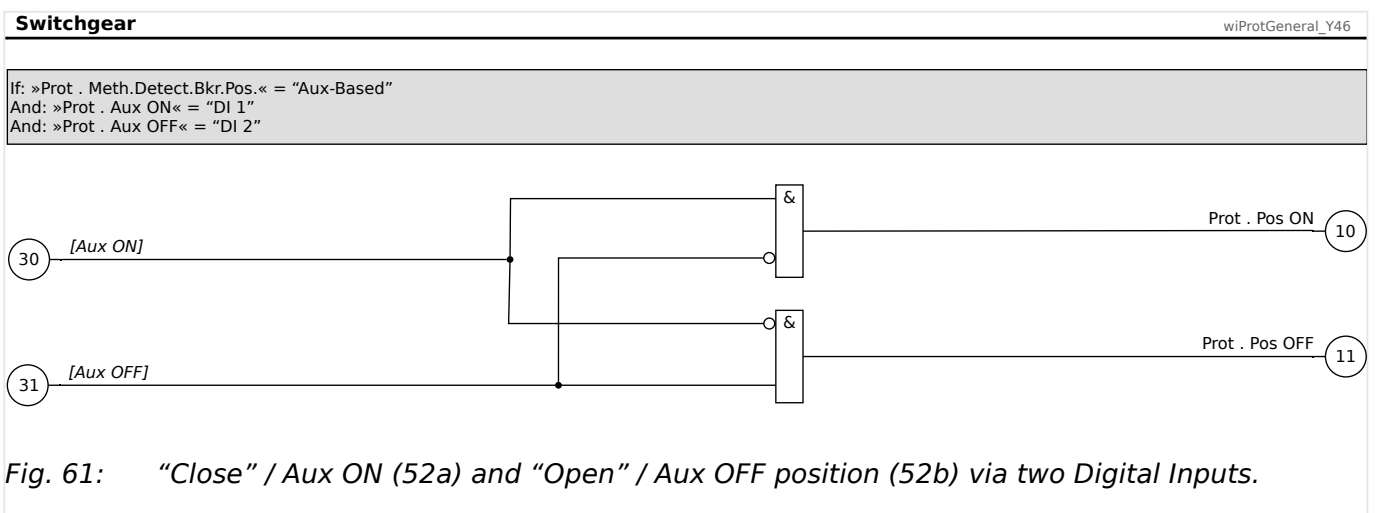

Position Indication, Part 5: Current-Based and Two Contacts

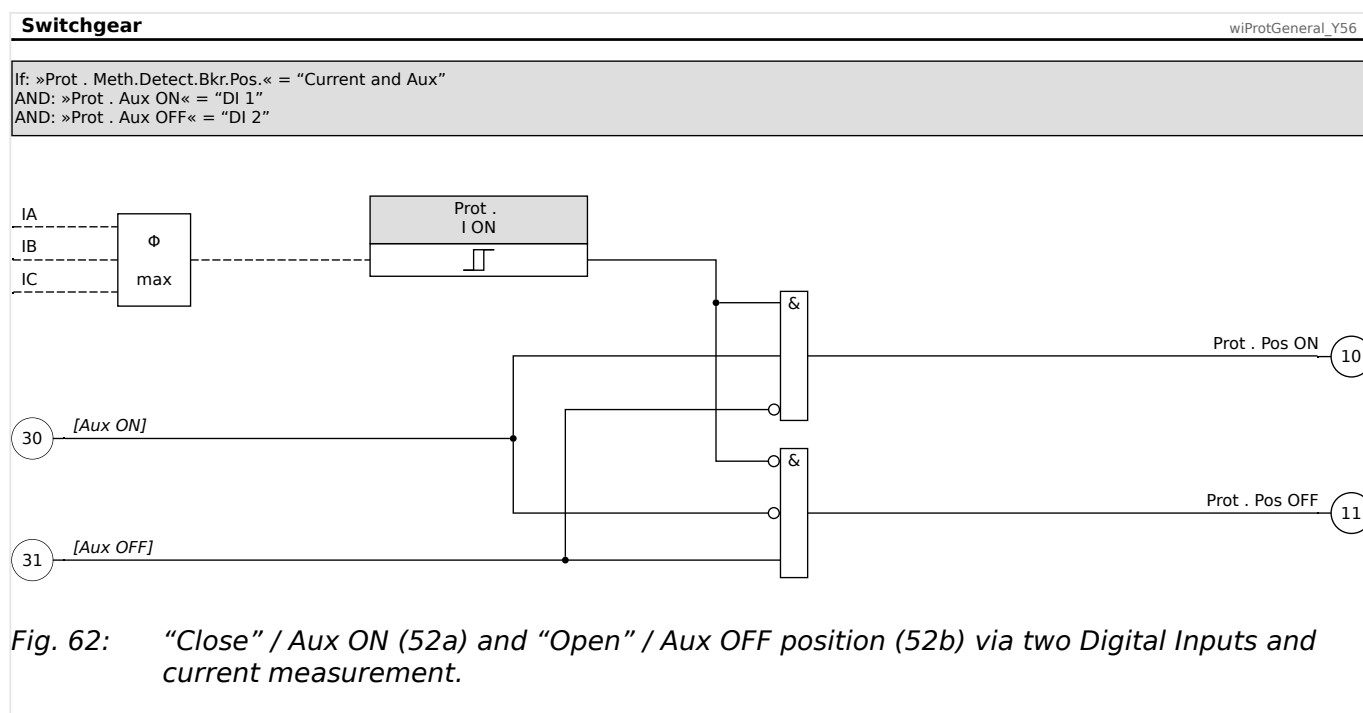

NOTICE!



Note that the position indication methods 3, 4, 5 shown above can result in neither signal (10) »Pos ON« nor signal (11) »Pos OFF« being active. This usually indicates an intermediate or faulty switchgear position.

5.2 Field Parameters

Within the field parameters you can set all parameters that are relevant for the primary side and the mains operational method.

These are in particular the setting of the rated CT current, ↪12.1.2 Setting of the Rated CT current I_n , but also e. g. the nominal frequency and phase sequence, ↪5.2.1 Field Parameter Settings via Smart view (PC) or DiggiMEC.

All field parameters are accessible via the menu branch [Field Para].

5.2.1 Field Parameter Settings via Smart view (PC) or DiggiMEC

⚙	
1. ▷	<p>Select the Phase Sequence:</p> <ul style="list-style-type: none"> • [Field Para / General Settings] »Phase Sequence« = <p>Options:</p> <ul style="list-style-type: none"> ◦ “ABC” — “rotating clockwise” phase sequence. ◦ “ACB” — “rotating counter-clockwise” phase sequence.
2. ▷	<p>Select the nominal frequency:</p> <ul style="list-style-type: none"> • [Field Para / General Settings] »f« = <p>Options:</p> <ul style="list-style-type: none"> ◦ “50” — nominal frequency $f_N = 50$ Hz. ◦ “60” — nominal frequency $f_N = 60$ Hz.
3. ▷	<p>Select whether the current measurement is based on the “Fundamental” or if “True RMS” measurement is used.</p> <ul style="list-style-type: none"> • [Field Para / General Settings] »CT . Measuring method« = <p>Options:</p> <ul style="list-style-type: none"> ◦ “Fundamental” ◦ “True RMS”
4. ▷	<p>If your WIC1 variant features a ground current measuring input, select whether the ground current protection shall operate with calculated or measured ground (earth) current:</p> <ul style="list-style-type: none"> • [Field Para / General Settings] »CT . IG Source« = <p>Options:</p> <ul style="list-style-type: none"> ◦ “calculated” — use calculated ground (earth) current. ◦ “measured” — use measured ground (earth) current.
5. ▷	<p>Specify the properties of the Current Transformers, in particular the CT type and the relative or primary rated current.</p> <ul style="list-style-type: none"> • [Field Para / CT] »CT . CT Type« = <p>Options:</p> <ul style="list-style-type: none"> ◦ “Relative” — Current values can only be displayed as relative values.

- “WE2 : 16 A ... 56 A” ... “W6 : 256 A ... 896 A” — Current values can also be displayed as primary values, based on this CT type (and based on the primary value of the rated current set at »CT pri«, see below).
 - “WC1” — Current values can also be displayed as primary values, assuming that an Converter CTs for 1 A / 5 A is used. (See ↪3.3.2 WIC1-WC Converter CTs (1 A / 5 A Measurement)). The primary value of the rated current is set at »CT pri«, see below)
 - Depending on this setting, the rated current is set either as a relative current or as a primary value. (See also ↪2.9 Measuring Values.)
 - [Field Para / CT] »CT . In,relative« — This is the relative rated current in units of [In,min], i. e. a rated current value without the CT type dependency (see ↪12.1.2 Setting of the Rated CT current In).
 - [Field Para / CT] »CT pri« — This is the primary value of the rated current in [A].
- 6.** ▷ If a CT type has been set it is possible to set the display of current values to primary values:
- [Field Para / CT] »CT . Display of Meas. Values« =
Options:
 - “Based on In,relative” — Current values are displayed as relative values.
 - “Primary current values” — Current values are displayed as primary values, based on the configured CT data.
- 7.** ▷ If your device features a ground (earth) current measuring input, specify the properties of the Ground Current Transformers.
- [Field Para / CT] »CT . ECT pri« — the primary nominal ground current in Ampere.

5.3 I>, I>>, I>>> - Phase Overcurrent Protection [50, 51]

The Phase Overcurrent modules I>, I>>, and I>>> cover overcurrent stages, that can be set up (independently of each other) as the following protection functions:

- **DEFT** = IEEE C37.2 / ANSI 50 — Definite-Time overcurrent protection, non-directional
Characteristic see [↔12.2.1.1 DEFT - Definite Time-Overcurrent \(I>, I>>, I>>>\)](#)
- IEEE C37.2 / ANSI 51 — Inverse-Time overcurrent protection, non-directional
Available characteristics see [↔12.2.1 Characteristics \(I>, I>>, I>>>\)](#)

For general information about the concept of WIC1 protection functions, see [↔5.1 »Prot« - General Protection Module](#).

5.3.1 Functionality

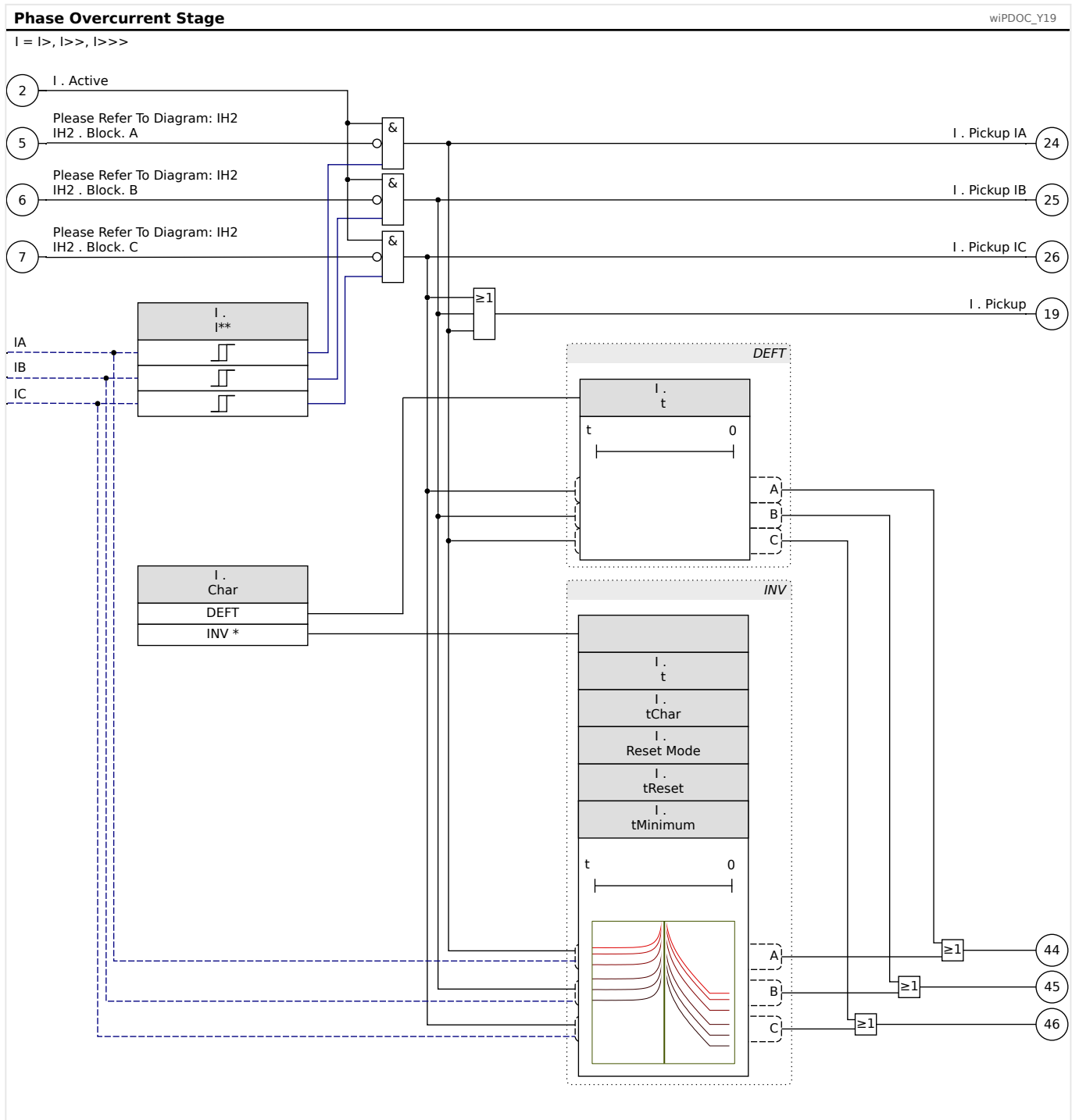

Fig. 63: Phase Overcurrent functionality, part 1 – pickup.

* "INV" symbolizes a selected inverse-time characteristics.

** For „INV“ threshold is $1.1 \cdot „I“$. Calculation of reset delay for the option »Reset Mode« = “inverse time” begins for currents below $0.9 \cdot „I“$.

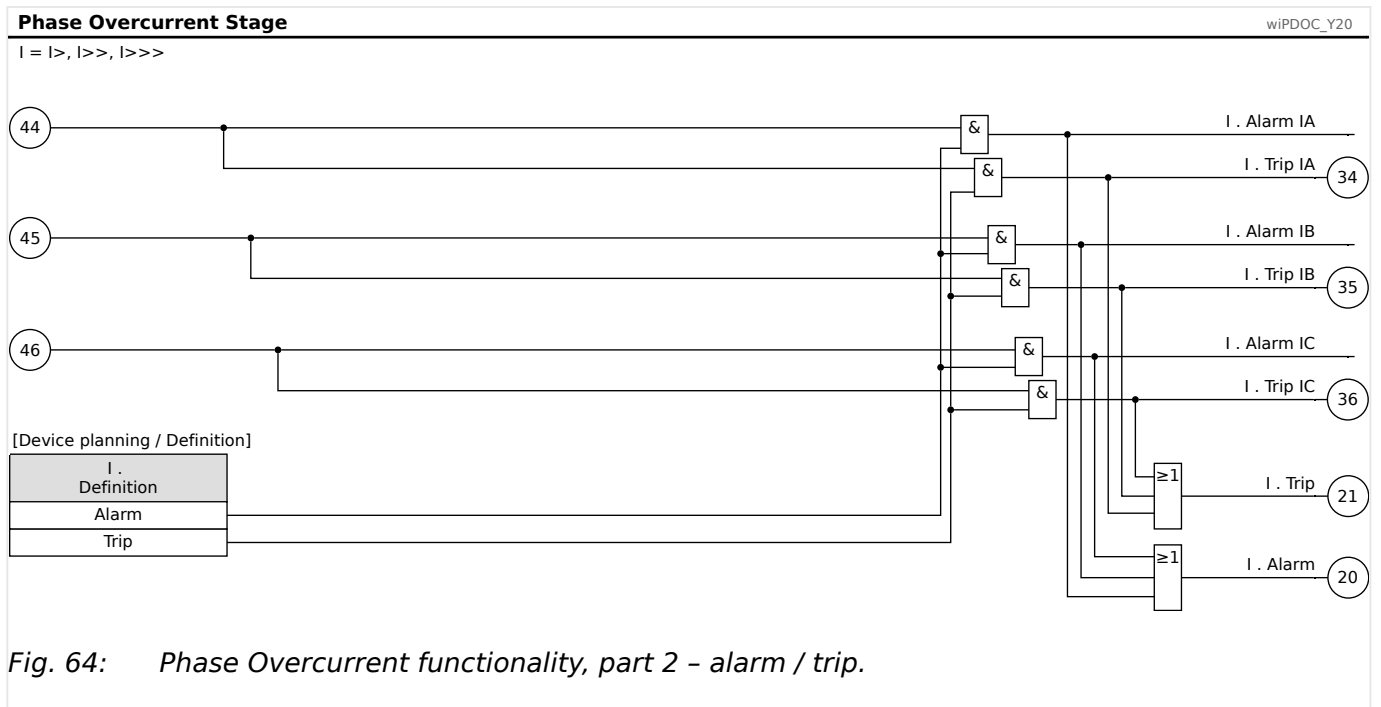

Fig. 64: Phase Overcurrent functionality, part 2 – alarm / trip.

5.3.2 Phase Overcurrent Protection - Settings

WARNING!



Ensure that the actual overcurrent settings comply with the technical and thermal limits of the device, the CTs and the application!

Check the technical data ([↪10.1 Technical Data - WIC1](#)) for the permitted current input limits. When defining the protection settings, note that both current threshold and (delay) time must be set in consideration of the technical input limits.

- The thermal load capacity of the phase current inputs can be found here: [↪10.1.4 Phase Current Measurement](#). The diagram and table in [↪3.3 Current Transformers \(CTs\)](#) might also be useful.
- The thermal load capacity of the ground (earth) current inputs can be found here: [↪10.1.5 Ground Current Measurement](#).

Unless there are any additional/external protective means installed we have to recommend that you activate at least one phase overcurrent protection stage considering the WIC1 limits ($2.5 \cdot I_{n,max}$ for 2.5 s, 25 kA for 1 s).

If your WIC1 features a ground (earth) current measuring input, these considerations should be applied in the same manner for one of the two ground overcurrent protection stages »/G>«, »/G>>«.

Ignoring the permitted limits will damage the WIC1, making it non-functional, and this can possibly result in serious damages of your equipment and even serious injury.

DIP/HEX switches: [↪2 WIC1 - Introduction, Operation](#)

5.3.2.1 Phase Overcurrent Protection – Settings via Smart view (PC) or DiggiMEC

The following settings are listed for the example of the »I>« protection.
For the »I>>« and »I>>>« protection stages there are the same settings and features available.



1. ▷ Activate the protection stage and select whether it shall operate as a supervision or a protection function, see [↔5.1 »Prot« – General Protection Module](#).
2. ▷ Select the »I>« Phase Overcurrent **Characteristic**:
 - [Protection Para / I>] »I> . Char« =
 - Options:
 - “DEFT” (DEFinite-Time overcurrent),
 - or any of the Inverse-time characteristics listed in [↔12.2.1 Characteristics \(I>, I>>, I>>>\)](#).
3. ▷ Specify the »I>« Phase Overcurrent **pickup threshold** (as a number value in units of the nominal current I_n):
 - [Protection Para / I>] »I> . I«
4. ▷ Only in case of Definite-Time overcurrent »I> . Char« = “DEFT”:
Specify the »I>« Phase Overcurrent **tripping delay** (in seconds):
 - [Protection Para / I>] »I> . t«
5. ▷ Select the »I>« Phase Overcurrent **Reset Mode**, that controls the reset delay:
 - [Protection Para / I>] »I> . Reset Mode« =
 - Options:
 - “instantaneous” (immediate reset),
 - “definite time” (reset delay fixed to a particular time in seconds),
 - “inverse time” (reset delay depends on the selected characteristic. This option is not available for some curves, see [↔12.2.1 Characteristics \(I>, I>>, I>>>\)](#).)
6. ▷ Only in case of an Inverse-Time characteristic with fixed reset delay, »I> . Reset Mode« = “definite time”:
Specify the »I>« Phase Overcurrent **reset delay** (in seconds):
 - [Protection Para / I>] »I> . tReset«
 - (Remark: For the Definite-Time overcurrent, the reset delay always equals 0.)
7. ▷ Only in case of an Inverse-Time characteristic:
Specify the »I>« Phase Overcurrent **minimum trip delay** (in seconds, see [↔“Explanation for All Characteristics \(I>, I>>, I>>>\)”](#) for details):
 - [Protection Para / I>] »I> . tMinimum«
8. ▷ Only in case of an Inverse-Time characteristic:
Specify the »I>« Phase Overcurrent **tripping characteristic factor** (see [↔“Explanation for All Characteristics \(I>, I>>, I>>>\)”](#) for details):

- [Protection Para / I>] »I> . tChar«

9. ▷ If Inrush Blocking has been activated (see ↪5.4 IH2 - Inrush Blocking), select whether this Earth (Ground) Overcurrent stage shall be blocked in case of an inrush current:

- [Protection Para / I>] »IH2 Blo« =

Options:

- “Inactive” (no Inrush blocking of the ground overcurrent protection),
- “Active” (the Inrush Blocking module also blocks the ground overcurrent protection).

5.4 IH2 - Inrush Blocking

The energization of a transformer and voltage recovery cause inrush currents that can reach a multiple of the rated current, so that a pickup and even a trip of the overcurrent functions can be the result.

These pickup and trips are unwanted, and the Inrush module can prevent them (by blocking the overcurrent protection). But in case of high current faults, the situation is different: Then the Inrush blocking is unwanted because it will delay the necessary tripping: A fault with a DC offset causes a 2nd harmonic component. This can potentially result in CT saturation, especially in case of high fault currents. CT saturation increases the 2nd harmonic component furthermore. This can make the Inrush blocking module block protection stages temporarily, and in such a situation, this results in a delay of protection operation. Since the Inrush blocking is unwanted in this case the Inrush module does **not** operate if a settable threshold »*I_{max}*« is exceeded.

The Inrush module checks for the ratio of the 2nd harmonic to the 1st harmonic and releases a blocking signal unless at least one phase current is above a settable »*I_{max}*« threshold.

NOTICE!



An undelayed /instantaneous overcurrent protection stage always trips earlier than the Inrush element is able to react. Therefore always use the Inrush element in combination with a small trip delay, to prevent faulty tripping, instead of undelayed/instantaneous overcurrent protection.

3-phase Inrush Blocking

The amount of the 2nd harmonic can vary in each phase. It is possible that it is not high enough for an activation of inrush blocking in this phase. If it is required to avoid false tripping in such a situation the Inrush module can be set to 3-phase blocking (via setting »*IH2 . 3-ph Blo*« = "Active"). Then all three phases get blocked as soon as an inrush is detected in (at least) one phase.

Blocking of Protection Based on Negative-Sequence Current

High inrush currents can lead to a transient saturation of the phase CTs. When this happens during a transformer inrush the determination of (positive and negative) sequence currents yields incorrect results. Therefore it is recommended that the Inrush blocking signal blocks all protection functions that operate on the negative-sequence current. See [↔5.4.2 Inrush - Settings](#) for the settings.

Inrush Blocking of Ground Overcurrent Protection

High inrush currents can lead to a transient saturation of the phase CTs. If the phase currents are used to determine the ground current (which is the case for calculated ground current), this transient saturation can result in an incorrect ground current, which can then cause a false tripping of the ground overcurrent protection.

Therefore one usually wants for these application types, that the Inrush Blocking module also blocks the ground overcurrent protection. See [↔5.4.2 Inrush - Settings](#) for the settings.

5.4.1 Functionality

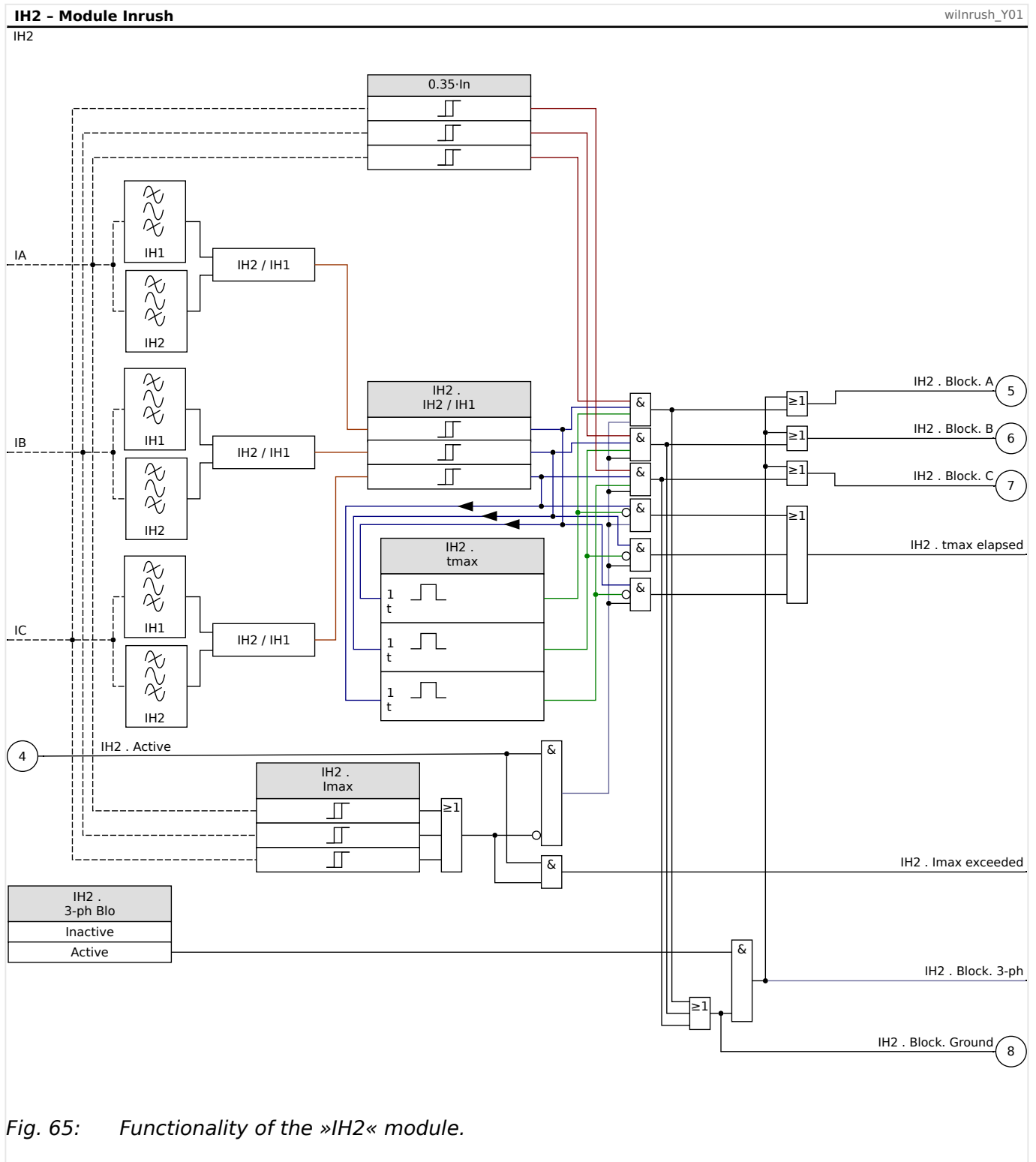

Fig. 65: Functionality of the »IH2« module.

5.4.2 Inrush - Settings

DIP/HEX switches: →2 WIC1 - Introduction, Operation

5.4.2.1 Inrush - Settings via Smart view (PC) or DiggiMEC



1. ▷ Activate the Inrush **module** »IH2«.
2. ▷ Specify the **threshold** for the ratio of the 2nd harmonic to the 1st harmonic:
 - [Protection Para / IH2] »IH2 . IH2 / IH1« — as a percentage.
3. ▷ Specify the **maximum current**, this is the upper limit for the Inrush module described [above](#):
 - [Protection Para / IH2] »IH2 . I_{max}« — as a number value in units of the nominal current I_n.
4. ▷ If required for your application, define a **maximum duration of the blocking signal**. (This is a phase-specific timer.)
 - [Protection Para / IH2] »IH2 . t_{max}« — in seconds.

The typical duration of high inrush currents during empowering a transformer depends on its rated power. These durations have roughly the following magnitude:

- For a rated power of 0.5 MVA, approx. 0.16 s,
- for a rated power of 1 MVA, approx. 0.2 s,
- for a rated power of 10 MVA, approx. 1.2 s,
- for a rated power above 10 MVA, more than 1.2 s up to several minutes.

(Durations cited from: Gerhard Ziegler, Digitaler Differentialschutz: Grundlagen und Anwendungen, 2. Aufl. 2013).

5. ▷ Select the **block mode**:
 - [Protection Para / IH2] »IH2 . 3-ph Blo« =
Options:
 - “Inactive” — phase-specific mode: Each phase gets blocked, for which an inrush current is detected.
 - “Active” — overall mode: All phases get blocked as soon as an inrush current is detected for at least one phase.

5.4.3 Commissioning: Inrush

The test procedure is dependent on the parameterized inrush-blocking-mode:

- [Protection Para / IH2] »IH2 . 3-ph Blo« = "Inactive":

For this mode, the test has to be carried out first for each individual phase and then for all three phases together.

- [Protection Para / IH2] »IH2 . 3-ph Blo« = "Active":

For this mode, the test is a three-phase one.

Object to be tested:

Test of inrush blocking.

Necessary means:

- three-phase current source with adjustable frequency,
- three-phase current source (for the first harmonic).

The current sources need to be connected in parallel.

Procedure (dependent on the parameterized blocking mode):

- It is recommended to set »IH2 . tmax« (temporarily) to a value that is large enough to manually check the Inrush blocking signals within the menu [Operation / Status Display / IH2].
- Feed the current to the secondary side with nominal frequency.
- Feed abruptly current to the secondary side with double nominal frequency. The amplitude must exceed the preset ratio/threshold »IH2 . IH2 / IH1«, but must not exceed the maximum current »IH2 . Imax«.
- Ascertain that the corresponding Inrush blocking signal is generated now: »IH2 . Block. A«, »IH2 . Block. B«, »IH2 . Block. C«

Successful test results:

The corresponding Inrush blocking signal is generated and can be checked at [Operation / Status Display / IH2], indicating the blocking of the current protection stage.

5.5 IG>, IG>> - Earth (Ground) Overcurrent Protection [50N/G, 51N/G]

The Earth (Ground) Overcurrent modules »IG>«, »IG>>« can be set up as any of the following [protection functions](#):

- **DEFT** = IEEE C37.2 / ANSI 50N/G — Definite-Time ground (earth) overcurrent protection, non-directional (see also [↔12.2.2.1 DEFT - Definite Time-Overcurrent \(IG>, IG>>\)](#)).
 - IEEE C37.2 / ANSI 50N is based on calculated ground (earth) current and always available,
 - IEEE C37.2 / ANSI 50G is based on measured ground (earth) current, and is available for WIC1 variants with ground/earth measuring input. (See [↔2.6.1 Order Forms](#).)
- IEEE C37.2 / ANSI 51N/G — Inverse-Time ground (earth) overcurrent protection, non-directional (characteristics see [↔12.2.2 Characteristics \(IG>, IG>>\)](#)).
 - IEEE C37.2 / ANSI 51N is based on calculated ground (earth) current and always available,
 - IEEE C37.2 / ANSI 51G is based on measured ground (earth) current, and is available for WIC1 variants with ground/earth measuring input. (See [↔2.6.1 Order Forms](#).)

For general information about the concept of WIC1 protection functions, see [↔5.1 »Prot« - General Protection Module](#).

5.5.1 Functionality

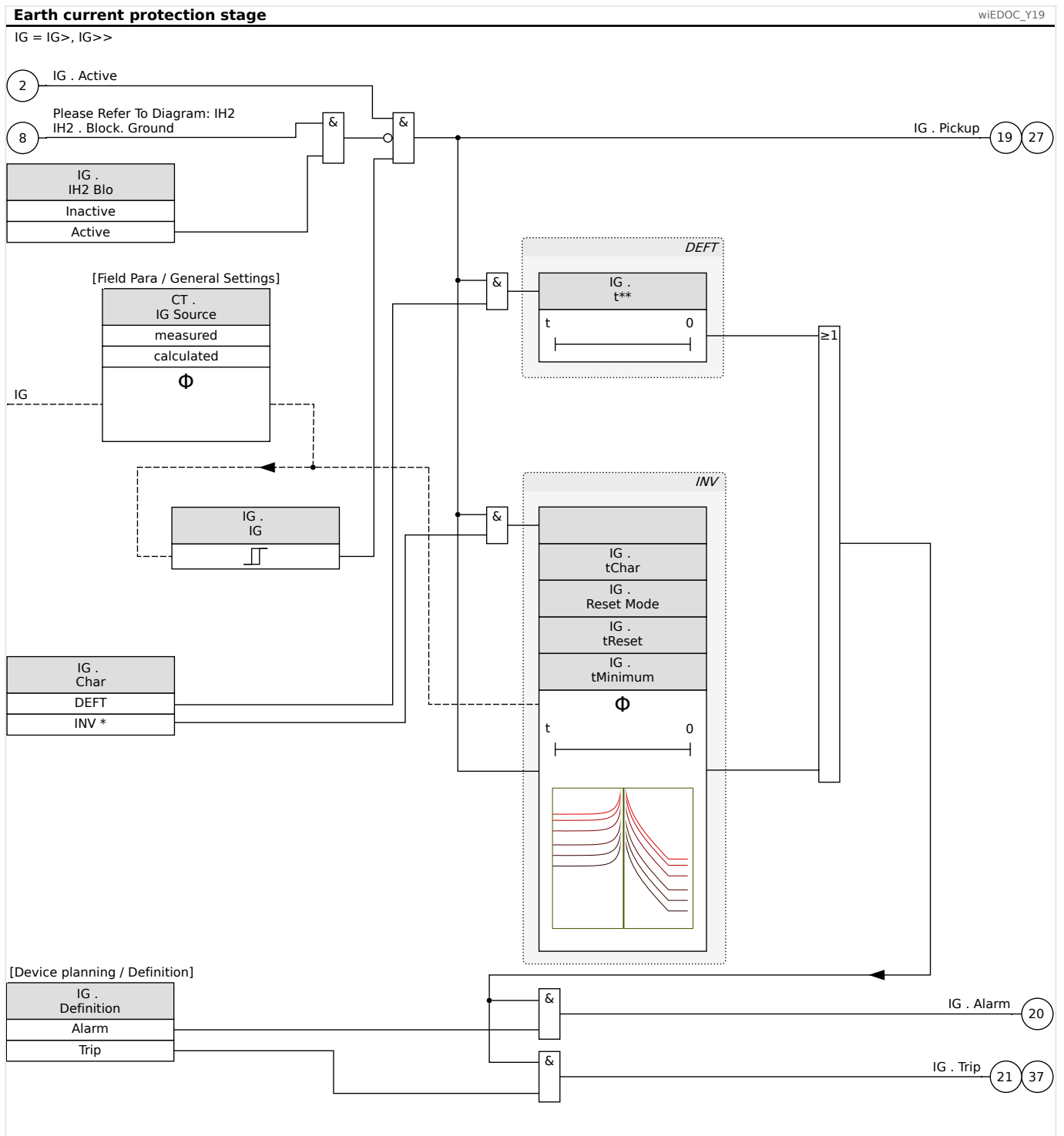

Fig. 66: Functionality of the ground (earth) overcurrent stages.

* "INV" symbolizes a selected inverse-time characteristics.

** For „INV“ threshold is $1.1 \cdot „IG“$. Calculation of reset delay for the option »Reset Mode« = "inverse time" begins for currents below $0.9 \cdot „IG“$.

5.5.2 Earth (Ground) Overcurrent Protection - Settings

WARNING!



In case of measured ground (earth) current:

Ensure that the actual overcurrent settings comply with the technical and thermal limits of the device, the CTs and the application!

Check the technical data ([↪10.1 Technical Data - WIC1](#)) for the permitted value ranges. When defining the ground overcurrent protection settings, note that both threshold and (delay) time must be set in consideration of the technical current input limits.

- The thermal load capacity of the ground (earth) current inputs can be found here: [↪10.1.5 Ground Current Measurement](#).

Unless there are any additional/external protective means installed we have to recommend that you activate at least one ground overcurrent protection stage considering the WIC1 limits.

Ignoring the permitted limits results will damage the WIC1, making it non-functional, and this can possibly result in serious damages of your equipment and even serious injury.

NOTICE!



The „nominal current“ (rated current) I_n is for all Earth (Ground) Overcurrent stages dependent on whether the ground (earth) current is measured or calculated. This is especially true of all settings parameters that are defined in units of I_n .

- Measured ground (earth) current, [Field Para / General Settings] »CT . IG Source« = “measured”:

I_n is the rated current of the ground (earth) CT, and the WIC1 currently supports 1 A ground (earth) CTs.

- Calculated ground (earth) current, [Field Para / General Settings] »CT . IG Source« = “calculated”:

I_n is the rated current of the phase CTs, and this corresponds to the setting [Field Para / CT] »CT . In,relative«. (See also [↪12.1.2 Setting of the Rated CT current \$I_n\$](#) and [↪5.2 Field Parameters](#).)

DIP/HEX switches: [↪2 WIC1 - Introduction, Operation](#)

5.5.2.1 Earth (Ground) Overcurrent Protection - Settings via Smart view (PC) or DiggiMEC

The following settings are listed for the example of the »IG>« protection. For the »IG>>« protection stage there are the same settings and features available.

	
1. ▷	Make sure all Field Parameters are set. In particular for ground (earth) overcurrent protection, select between calculated or measured ground current. See ↔5.2 Field Parameters .
2. ▷	Activate the protection stage and select whether it shall operate as a supervision or a protection function, see ↔5.1 »Prot« - General Protection Module .
3. ▷	Select the »IG>« Earth (Ground) Overcurrent Characteristic : <ul style="list-style-type: none"> • [Protection Para / IG>] »IG> . Char« = Options: <ul style="list-style-type: none"> ◦ “DEFT” (DEFinite-Time overcurrent), ◦ or any of the Inverse-time characteristics listed in ↔12.2.2 Characteristics (IG>, IG>>).
4. ▷	Specify the »IG>« Earth (Ground) Overcurrent pickup threshold (as a number value in units of the nominal current I_n): <ul style="list-style-type: none"> • [Protection Para / IG>] »IG> . IG«
5. ▷	Only in case of Definite-Time overcurrent »IG> . Char« = “DEFT”: Specify the »IG>« Earth (Ground) Overcurrent tripping delay (in seconds): <ul style="list-style-type: none"> • [Protection Para / IG>] »IG> . t«
6. ▷	Select the »IG>« Earth (Ground) Overcurrent Reset Mode , that controls the reset delay: <ul style="list-style-type: none"> • [Protection Para / IG>] »IG> . Reset Mode« = Options: <ul style="list-style-type: none"> ◦ “instantaneous” (immediate reset), ◦ “definite time” (reset delay fixed to a particular time in seconds), ◦ “inverse time” (reset delay depends on the selected characteristic. This option is not available for some curves, see ↔12.2.2 Characteristics (IG>, IG>>).)
7. ▷	Only in case of an Inverse-Time characteristic with fixed reset delay, »IG> . Char« = “definite time”: Specify the »IG>« Earth (Ground) Overcurrent reset delay (in seconds): <ul style="list-style-type: none"> • [Protection Para / IG>] »IG> . tReset« (Remark: For the Definite-Time overcurrent, the reset delay always equals 0.)
8. ▷	Only in case of an Inverse-Time characteristic: Specify the »IG>« Earth (Ground) Overcurrent minimum trip delay (in seconds, see ↔“Explanation for All Characteristics (IG>, IG>>)” for details): <ul style="list-style-type: none"> • [Protection Para / IG>] »IG> . tMinimum«
9. ▷	Only in case of an Inverse-Time characteristic:

Specify the »IG<< Earth (Ground) Overcurrent **tripping characteristic factor** (see [↔“Explanation for All Characteristics \(IG>, IG>>”](#) for details):

- [Protection Para / IG>] »IG> . *tChar*«

10. ▷ If Inrush Blocking has been activated (see [↔5.4 IH2 - Inrush Blocking](#)), select whether this Earth (Ground) Overcurrent stage shall be blocked in case of an inrush current:

- [Protection Para / IG>] »IH2 Blo« =

Options:

- “Inactive” (no Inrush blocking of the ground overcurrent protection),
- “Active” (the Inrush Blocking module also blocks the ground overcurrent protection).

5.5.3 Earth (Ground) Overcurrent Protection - Measuring Method

The WIC1 features Earth (Ground) Overcurrent Protection either with calculated or with measured earth (ground) current. The selection of the measuring method depends on the setting ranges of the parameter [Protection Para / IG>] »IG> . IG« which are different for each option. The calculated earth (ground) current can be used if the desired threshold setting is within the limits. Otherwise, the measured earth (ground) current should be selected.

Measuring Method	Setting Range	Reference current
Calculated	0.2In ... 10.0In	Nominal phase current setting [Field Para / CT] »CT . In,relative« or [Field Para / CT] »CT pri«
Measured	0.02In ... 10.0In	Nominal earth (ground) current setting [Field Para / CT] »CT . ECT pri«

The accuracy of the calculated earth (ground) current (↪10.1.5 Ground Current Measurement) should be taken into account by increasing [Protection Para / IG>] »IG> . IG« by 9% compared to the desired threshold setting.

For applications where high accuracy is mandatory, it is generally recommended to use the measured earth (ground) current.

Example 1

Desired pickup threshold	$I_e = 10 \text{ A}$
Nominal primary phase current	$I_n = 25 \text{ A}$

For the calculated Earth (Ground) Overcurrent Protection the accuracy should be taken into account as mentioned above. Therefore, the pickup threshold setting of the the WIC1 should be 9% higher than the desired threshold:

$$I_e \cdot 1.09 = 10 \text{ A} \cdot 1.09 = 10.9 \text{ A} = 0.44 I_n$$

This value must be within the setting range for calculated earth (ground) current:

$$0.2 I_n \leq 0.44 I_n \leq 10.0 I_n$$

The value is inside the setting range. Therefore, the calculated earth (ground) current can be used for the given application.

Example 2

Desired pickup threshold	$I_e = 5 \text{ A}$
Nominal primary phase current	$I_n = 40 \text{ A}$

Analog to the example above the desired pickup threshold is increased by 9%:

$$I_e \cdot 1.09 = 5 \text{ A} \cdot 1.09 = 5.45 \text{ A} = 0.14 I_n$$

This value must be within the setting range for calculated earth (ground) current:

$$0.14 I_n \leq 0.2 I_n \leq 10.0 I_n$$

The value is outside of the setting range. Therefore, the measured earth (ground) current should be used for the given application.

Additional hints

It should also be taken into account the WIC1 has some restrictions in self-powered mode for the Earth (Ground) Overcurrent protection, because the supply is taken from the phase current inputs.

- The calculated earth (ground) current is only available if phase currents are high enough to supply the WIC1 stable. More details are found under [↪10.1.5 Ground Current Measurement](#).
- The measured earth (ground) current input can detect very low currents, but the WIC1 may not be capable, or only delayed, to initiate a trip impulse, if phase currents are too low to deliver enough energy. More details on this topic are found under [↪10.1.6 Power Supply](#).

5.6 I2/I1> - Unbalanced Load [46]

The protection function »I2/I1>« is similar to the Phase Overcurrent protection. The main difference is that the Phase Overcurrent protection monitors the three phase currents, whereas the »I2/I1>« module monitors the negative-sequence current I2 (in comparison with the positive-sequence current I1).

- IEEE C37.2 / ANSI 46 — Unbalanced Load Protection.

For general information about the concept of WIC1 protection functions, see [↔5.1 »Prot« - General Protection Module](#).

NOTICE!



High inrush currents can lead to a transient saturation of the phase CTs. When this happens during a transformer inrush the determination of (positive and negative) sequence currents yields incorrect results.

5.6.1 Functionality

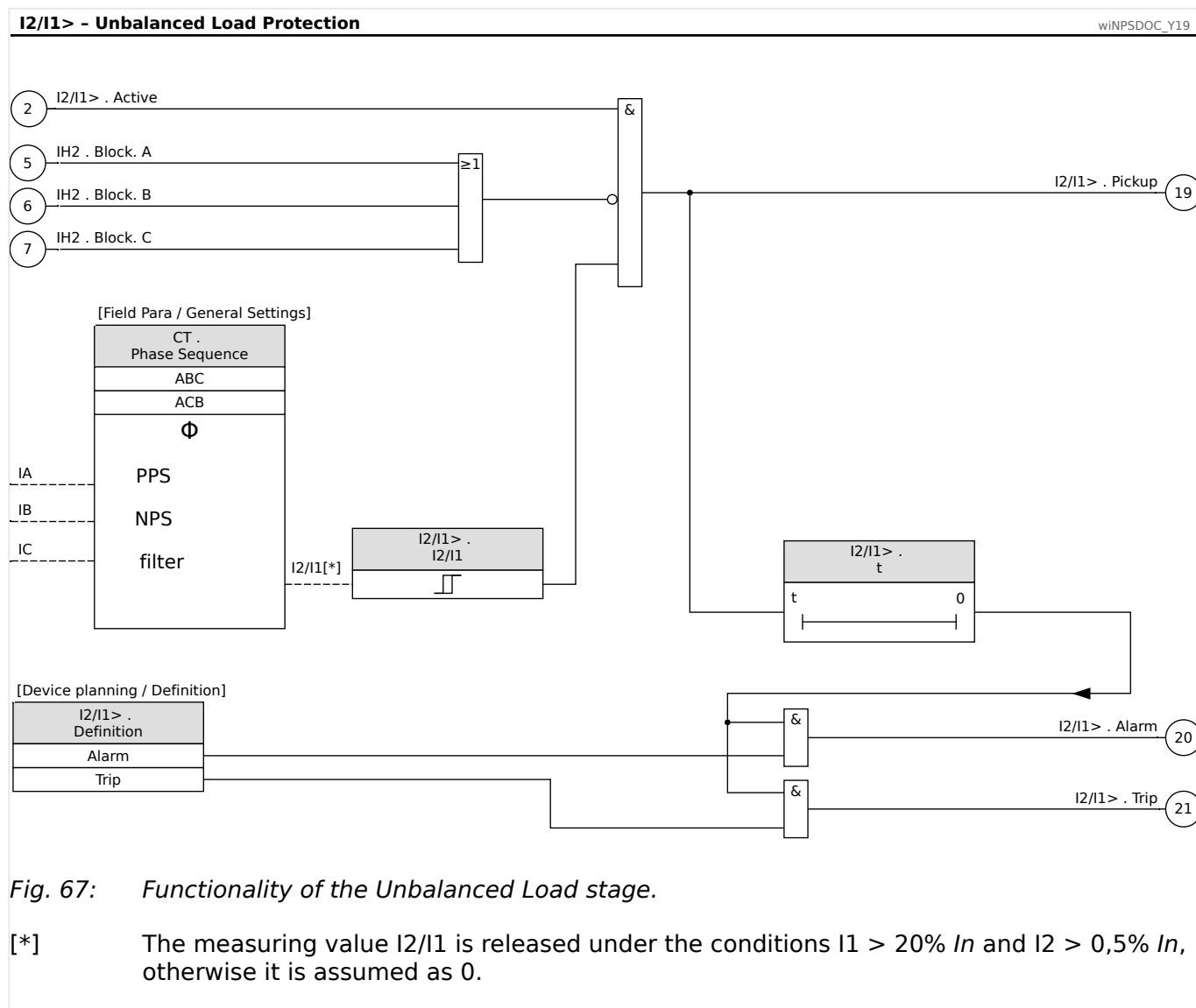

5.6.2 Current Unbalance Protection - Settings via Smart view (PC) or DiggiMEC



1. ▷ Activate the protection stage and select whether it shall operate as a supervision or a protection function, see [↔5.1 »Prot« - General Protection Module](#).
2. ▷ Specify the »I2/I1>« **pickup threshold**:
 - [Protection Para / I2/I1>] »I2/I1> . I2/I1« — as a percentage.
3. ▷ Specify the **tripping delay** (in seconds):
 - [Protection Para / I2/I1>] »I2/I1> . t«
4. ▷ If Inrush Blocking has been activated (see [↔5.4 IH2 - Inrush Blocking](#)), select whether this Earth (Ground) Overcurrent stage shall be blocked in case of an inrush current:
 - [Protection Para / I2/I1>] »IH2 Blo« =

Options:

 - “Inactive” (no Inrush blocking of the ground overcurrent protection),
 - “Active” (the Inrush Blocking module also blocks the ground overcurrent protection).

5.7 I2> - Negative-Sequence Current Protection [51Q]

The protection function »I2>« is similar to the Phase Overcurrent protection. The main difference is that the Phase Overcurrent protection monitors the three phase currents, whereas the »I2>« module monitors the negative-sequence current I2.

- IEEE C37.2 / ANSI 51Q — Negative-Sequence Current Protection,
available characteristics see [↔12.2.3 Characteristics »I2>«](#).

For general information about the concept of WIC1 protection functions, see [↔5.1 »Prot« - General Protection Module](#).

NOTICE!



High inrush currents can lead to a transient saturation of the phase CTs. When this happens during a transformer inrush the determination of (positive and negative) sequence currents yields incorrect results.

5.7.1 Functionality

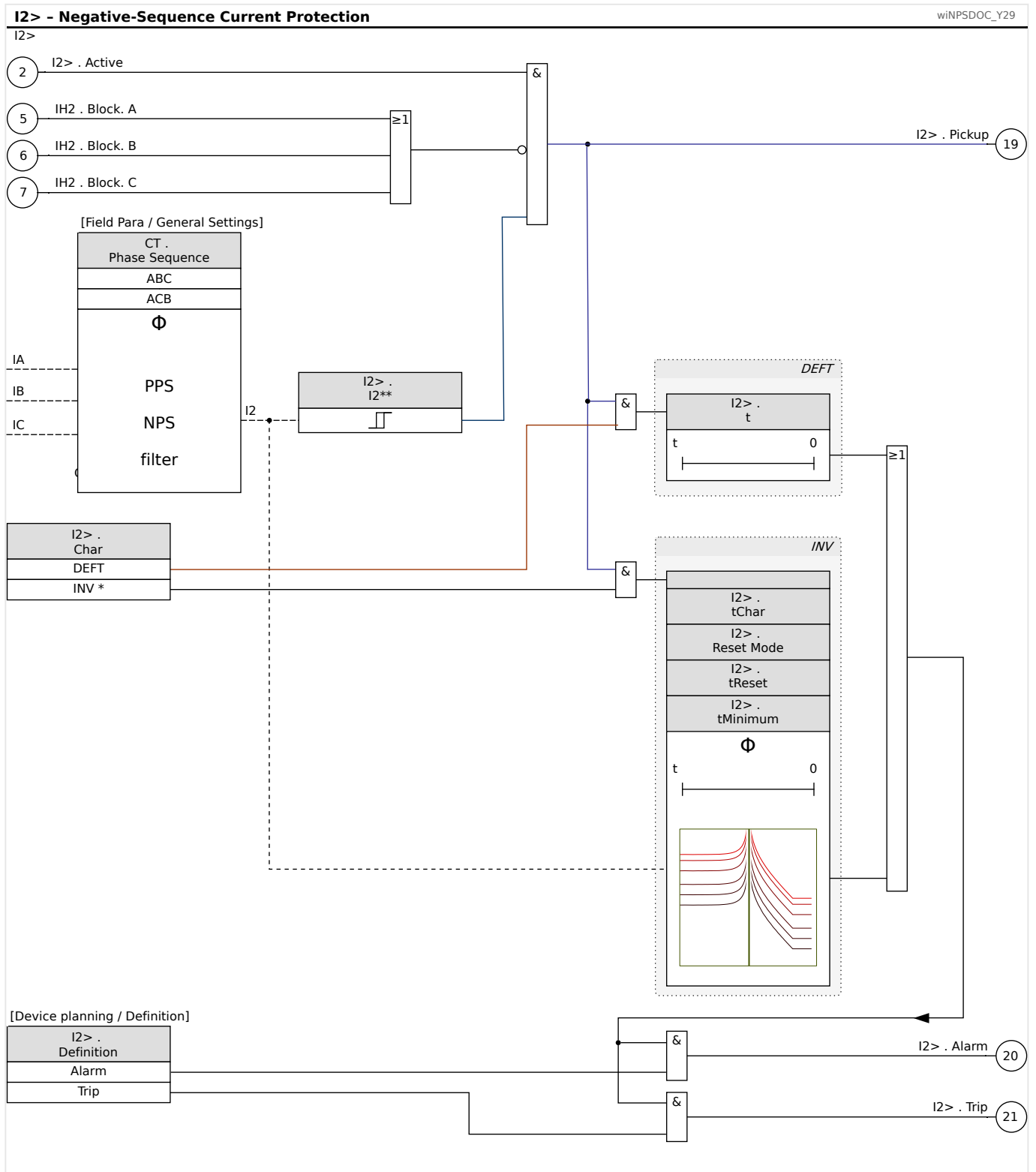

Fig. 68: Functionality of the Negative-Sequence Current protection.

* "INV" symbolizes a selected inverse-time characteristics.

** For „INV“ threshold is $1.1 \cdot „I2“$. Calculation of reset delay for the option »Reset Mode« = "inverse time" begins for currents below $0.9 \cdot „I2“$.

5.7.2 Settings via Smart view (PC) or DiggiMEC



1. ▷ Activate the protection stage and select whether it shall operate as a supervision or a protection function, see [↔5.1 »Prot« - General Protection Module](#).
2. ▷ Select the **Characteristic**:
 - [Protection Para / I2>] »I2> . Char« =
Options:
 - “DEFT” (DEFinite-Time),
 - or any of the Inverse-time characteristics listed in [↔12.2.3 Characteristics »I2>«](#).
3. ▷ Specify the **pickup threshold**:
 - [Protection Para / I2>] »I2> . I2 — as a number value in units of the nominal current In.
4. ▷ Only in case of the Definite-Time characteristic »I2> . Char« = “DEFT”:
Specify the **tripping delay** (in seconds):
 - [Protection Para / I2>] I2> . t«
5. ▷ Only in case of an Inverse-Time characteristic, select the **Reset Mode**, that controls the reset delay:
 - [Protection Para / I2>] »I2> . Reset Mode« =
Options:
 - “instantaneous” (immediate reset),
 - “definite time” (reset delay fixed to a particular time in seconds),
 - “inverse time” (reset delay depends on the selected characteristic. This option is not available for some curves, see [↔12.2.3 Characteristics »I2>«](#).)
6. ▷ Only in case of an Inverse-Time characteristic with fixed reset delay, »I2> . Reset Mode« = “definite time”:
Specify the **reset delay** (in seconds):
 - [Protection Para / I2>] »I2> . tReset«
(Remark: For the Definite-Time overcurrent, the reset delay always equals 0.)
7. ▷ Only in case of an Inverse-Time characteristic:
Specify the **minimum trip delay** (in seconds, see [↔“Explanation for All Characteristics »I2>«”](#) for details):
 - [Protection Para / I2>] »I2> . tMinimum«
8. ▷ Only in case of an Inverse-Time characteristic:
Specify the **tripping characteristic factor** (see [↔“Explanation for All Characteristics »I2>«”](#) for details):
 - [Protection Para / I2>] »I2> . tChar«

9. ▷ If Inrush Blocking has been activated (see ↔5.4 IH2 - Inrush Blocking), select whether this Earth (Ground) Overcurrent stage shall be blocked in case of an inrush current:

- [Protection Para / I2>] »IH2 Blo« =

Options:

- “Inactive” (no Inrush blocking of the ground overcurrent protection),
- “Active” (the Inrush Blocking module also blocks the ground overcurrent protection).

5.8 ThR - Thermal Overload [49]

The thermal overload protection »ThR« protects the connected object against overload.

The amount of overload is determined based on the measured RMS phase currents. The thermal overload module »ThR« provides two different overload warning levels:

- The Pre-Alarm level is settable via »*Pre-Alarm Lev.*« between 50% and 100% and issues a Pre-Alarm signal if the set value is exceeded.
- The Trip level is fixed at 100%. If this level is reached a Pickup signal and either a Trip (Operate) or an Alarm signal are issued.

The WIC1 calculates the thermal load of the equipment by using the existing measured values and the parameter settings. When knowing the thermal constants, the temperature of the equipment can be established (simulated).

The thermal level is reset to zero in any of the following cases:

- a change of the configuration (i. e. changed settings / parameters);
- as soon as the thermal overload module is deactivated (signal »ThR . Active« = "False").
- manually, via the Direct Control [Operation / Reset] »*Rst. Thermal Lev.*«.

Tripping Time

The general tripping times of the overload protection can be gathered from the following equation:

$$t = \tau\text{-warm} \cdot \ln\left(\frac{I^2 - I_p^2}{I^2 - (K \cdot I_b)^2}\right)$$

Legend:

- t = tripping time
- $\tau\text{-warm}$ = warming-up time constant
- $\tau\text{-cool}$ = cooling time constant
- I_b = base current: maximum permissible thermal continuous current
- K = overload factor: The maximum thermal limit is defined as $K \cdot I_b$, the product of the overload factor and the base current.
- I = measured current (in units of In)
- I_p = preload current

5.8.1 Functionality

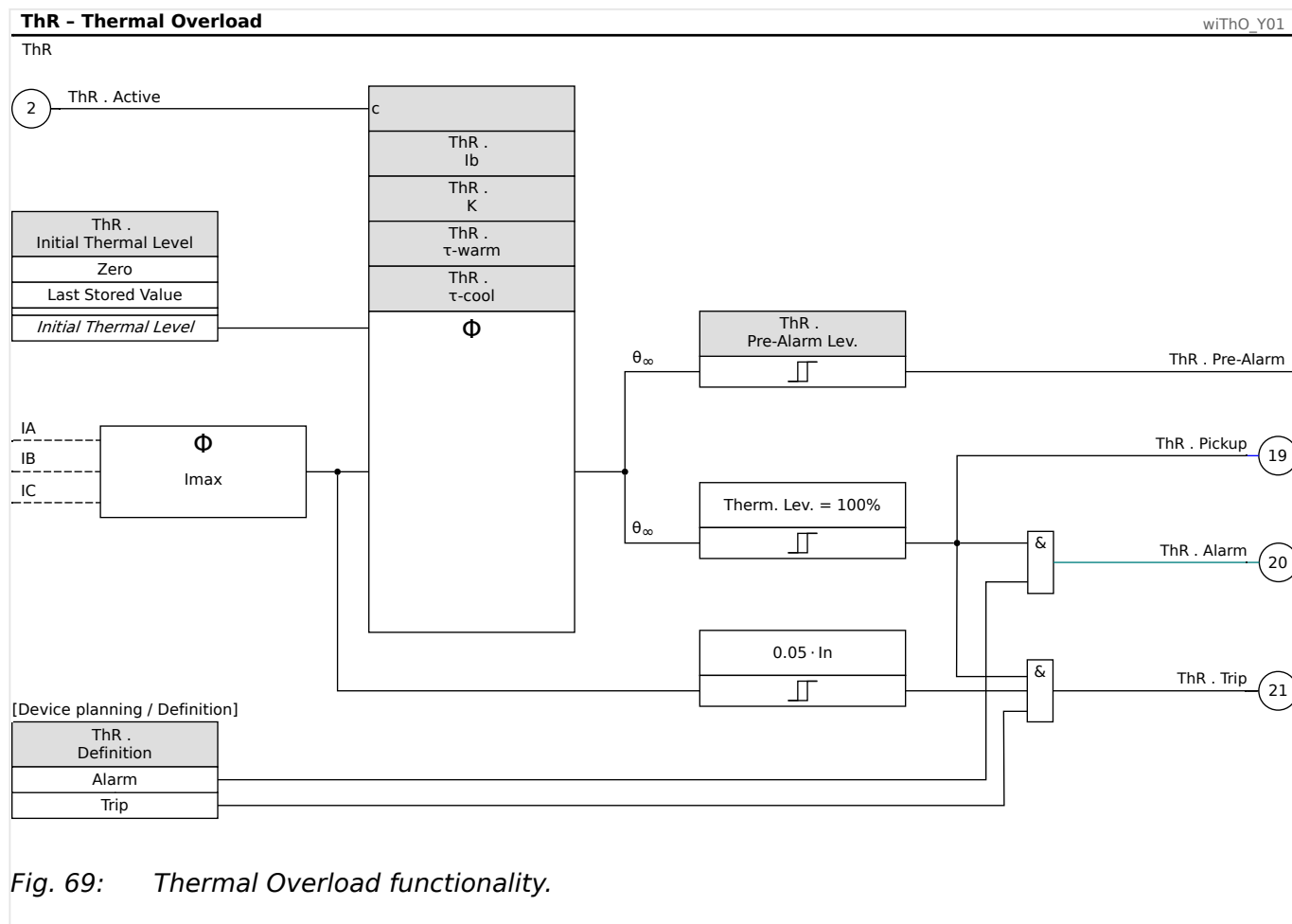

Fig. 69: Thermal Overload functionality.

5.8.2 Thermal Overload – Settings via Smart view (PC) or DiggiMEC



1. ▷ Activate the protection stage and select whether it shall operate as a supervision or a protection function, see [↔5.1 »Prot« – General Protection Module](#).
2. ▷ Specify the **base current**. This is the maximum permissible thermal continuous current:
 - [Protection Para / ThR] »ThR . Ib« — as a number value in units of the nominal current In.
3. ▷ Specify the **Overload Factor**. This is a number without unit, and when it is multiplied with the base current then the result is the maximum thermal limit:
 - [Protection Para / ThR] »ThR . K« — as a number value without a unit.
4. ▷ Specify the **warming-up time constant** and the **cooling time constant**:
 - [Protection Para / ThR] »ThR . τ -warm« — as a time value in seconds.
 - [Protection Para / ThR] »ThR . τ -cool« — as a time value in seconds.
5. ▷ Specify the **Pre-Alarm level** (see the description at the beginning of this chapter):
 - [Protection Para / ThR] »ThR . Pre-Alarm Lev.« — as a percentage.
6. ▷ Select a **criterion** that defines the initial value of the thermal capacity in case of a device restart:
 - [Protection Para / ThR] »ThR . Initial Thermal Level« =
Options:
 - “Zero” — The initial value is set to zero.
 - “Last Stored Value” — The initial value is set to the last known value but limited to max. 95%. (Without the limit, a restart after a thermal trip, i. e. a trip with $\theta \geq 100\%$, would use an initial value $\geq 100\%$, so that the Thermal Overload protection would immediately trip again.)

5.9 Ipeak> - Peak Overcurrent Protection

The Peak Overcurrent module »Ipeak>« is aiming at extremely short detection and operating times (approx. $\frac{1}{2}$ period). It is primarily used for detecting a switching onto an earthing and short-circuiting device, and therefore it is generally used in combination with the Switch Onto Fault ([SOTF](#)) protection.

It monitors unfiltered phase current measurement values and checks whether these exceed a particular peak threshold, and this way very fast tripping times can be achieved. But on the other hand, there is no suppression of the DC component and no suppression of harmonics.

The »Ipeak>« is useful if and only if the following aspects are essential for the application:

- A very fast tripping time is the top priority (instead of all other aspects, especially those requiring a Fourier filtering).
- The peak threshold is far above the inrush current (because it is not possible to block this protection stage by an [Inrush Blocking](#)).

In case of different requirements / priorities, you should consider using the [Phase Overcurrent](#) protection instead.

For general information about the concept of WIC1 protection functions, see [↔5.1 »Prot« – General Protection Module](#).

5.9.1 Functionality

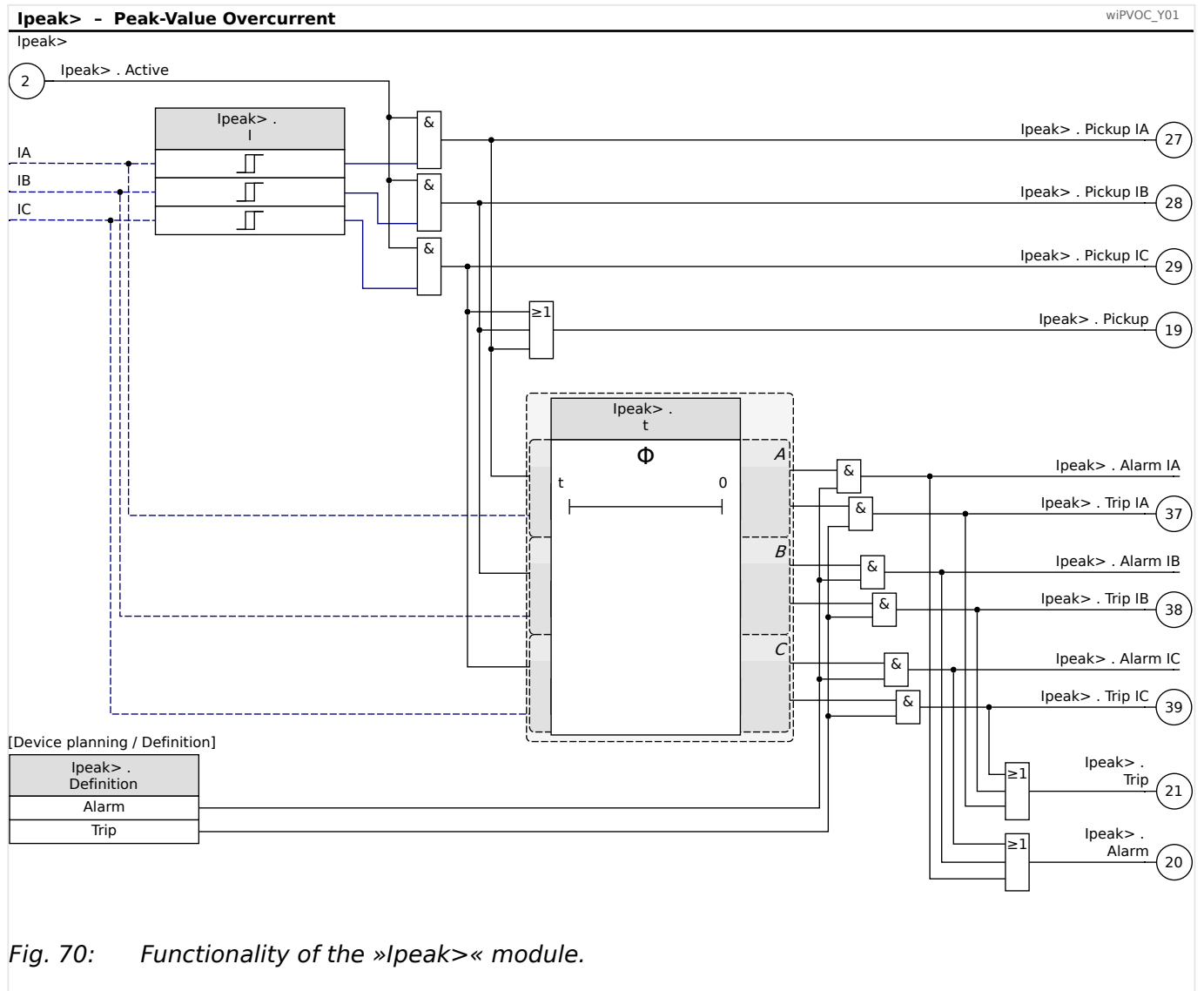



Fig. 70: Functionality of the »Ipeak>« module.

5.9.2 Ipeak> - Settings

DIP/HEX switches: [↔2 WIC1 - Introduction, Operation](#)

5.9.2.1 Ipeak> - Settings via Smart view (PC) or DiggiMEC

	
1.	▷ Activate the protection stage and select whether it shall operate as a supervision or a protection function, see ↔5.1 »Prot« - General Protection Module .
2.	▷ Select between Supervision only or protection tripping: <ul style="list-style-type: none">• [Device planning / Definition] »Ipeak> . Definition« = Options:<ul style="list-style-type: none">◦ “Alarm” — In case of a detected overcurrent, the module issues only an alarm signal »Ipeak> . Alarm . Alarm« but does not trip the circuit breaker.◦ “Trip” — In case of a detected overcurrent, the module issues a trip signal »Ipeak> . Trip and trips the circuit breaker.
3.	▷ Specify the pickup threshold : <ul style="list-style-type: none">• [Protection Para / Ipeak>] »Ipeak> . I« — as a number value in units of the nominal current I_n. Note that the device has an internal factor of $\sqrt{2}$ due to its use of peak values: A setting value of, for instance, $8 \cdot I_n$ means a pickup at a current value $i(t) \geq \sqrt{2} \cdot 8 \cdot I_n$.
4.	▷ Specify the tripping delay (in seconds): <ul style="list-style-type: none">• [Protection Para / Ipeak>] »Ipeak> . t« Note, however, that due to the general concept of this protection module, only an instantaneous tripping ($\text{»Ipeak> . t«} = 0$) makes sense in most applications.

5.10 SOTF - Switch Onto Fault

In case a faulty line is energized (e. g. when an earthing switch is in closed position), an instantaneous trip is recommended. This requirement can be fulfilled from the »SOTF« module, which is only active for a limited period of time after re-energization and allows instantaneous (or time delayed) tripping. The activation conditions can be selected from two different settings:

- With the setting »Enabling« = “Close Command”: activation of SOTF after the circuit breaker has been closed manually. The close command is recognized based on the (rising edge of the) external signal »Prot . SCmd ON« (see also [↪5.1.4.1 Switch ON Command \(external\)](#)).
- With the setting »Enabling« = “Breaker Pos.”: activation of SOTF with the OPENED position of the circuit breaker, and the activation continues until the OPENED position drops off, plus the timer setting »SOTF . t-enable« (The breaker position is determined according to the settings described in [↪“Criteria for Determining the Switchgear Position”](#)). The following should be noted when using this setting:
 - A device restart always activates SOTF. This is because a WIC1 in self-powered mode is off if the current breaker is open and no power supply via the phase CTs is available. The device starts as soon as the breaker is closed. Therefore, this event activates SOTF.
 - WIC1-4 with auxiliary power supply and current based breaker position determination only: the CLOSED state activates SOTF only after the circuit breaker has been OPENED for at least 3 minutes (This duration is a fixed device-internal time). The timer should prevent activation of SOTF from load current fluctuations. Position based breaker position determination via digital inputs does not have this time based restriction.

Depending on the setting of »Trigger«, the SOTF condition is recognized by a pickup signal from one of the [phase overcurrent](#) modules or from the [peak overcurrent](#) module, or by a [\(general\) protection pickup](#).

Functionality of the »SOTF« Module

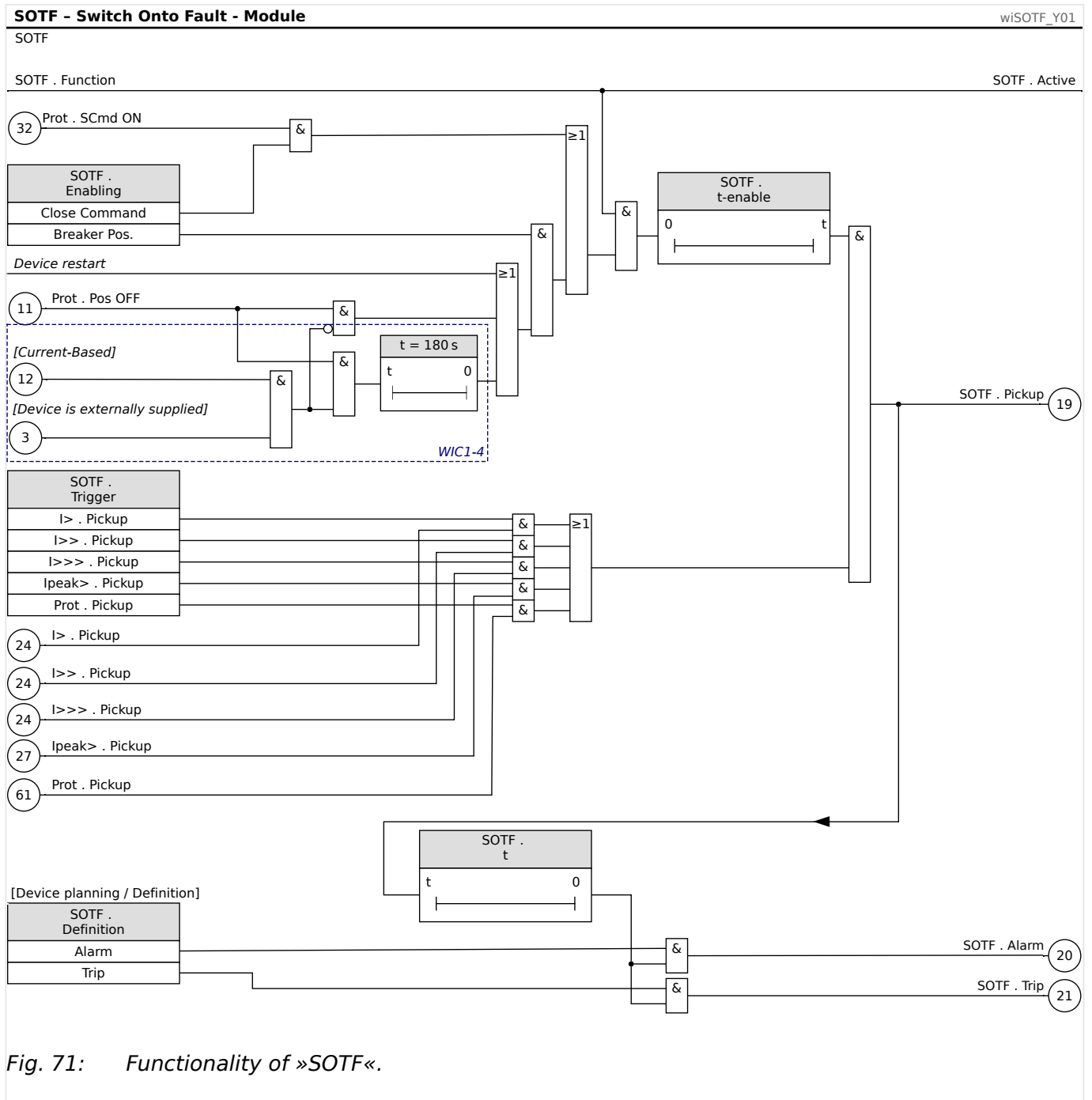

5.10.1 SOTF - Settings via Smart view (PC) or DiggiMEC



1. ▷ Activate the protection stage and select whether it shall operate as a supervision or a protection function, see [↔5.1 »Prot« - General Protection Module](#).
2. ▷ Set the **activating condition**, as described [at the beginning of this chapter](#):
 - [Protection Para / SOTF] »SOTF . Enabling« =
Available options depend on device variant:
 - “Close Command”, “Breaker Pos.”.
3. ▷ Set the **trigger mode** by selecting which pickup signal shall trigger the »SOTF« module:
 - [Protection Para / SOTF] »SOTF . Trigger« =
Options:
 - “I> . Pickup” — Pickup of the »I>« phase overcurrent.
 - “I>> . Pickup” — Pickup of the »I>>« phase overcurrent.
 - “I>>> . Pickup” — Pickup of the »I>>>« phase overcurrent.
 - “Ipeak> . Pickup” — Pickup of the »Ipeak>« peak overcurrent.
 - “Prot . Pickup” — General Pickup (issued by the »Prot« module).

Note that depending on your other settings, the selected protection pickup can be (temporarily) blocked by the [Inrush Blocking](#) function. In this case, the »SOTF« does not get triggered, and the protection concept should take care of this.
4. ▷ Specify the **activity duration** (in seconds). »SOTF« is active for this period of time after the circuit breaker has been closed manually after a restart in CT-powered operation:
 - [Protection Para / SOTF] »SOTF . t-enable«.
5. ▷ Specify the **tripping delay** (in seconds). (A typical setting for this is “0 seconds”, i. e. instantaneous tripping.)
 - [Protection Para / SOTF] »SOTF . t«.

5.11 CLPU - Cold Load Pickup (WIC1-4 only*)

* This protection function is only usable with an external power supply. Therefore it is available only for WIC1-4 devices.

After a long outage, some types of objects to be protected – e. g. motors – have a higher current magnitude during re-energization, than would be the case after a short outage. If this cold load current exceeds an overcurrent protection threshold this can result in a false protection trip.

The Cold Load Pickup function can be used to stabilize the overcurrent stages (i. e. prevent an unwanted pickup / trip) during a re-energization after a long outage. This is available (individually) for each phase overcurrent and ground (earth) overcurrent stage.

Via setting parameter »50/51 Stab.«, the user can select one out of two different stabilization methods:

- “Factor” - The pickup threshold is (temporarily) increased during re-energization.
- “Block.” - The overcurrent stage is (temporarily) blocked during re-energization.

The duration »tStab« of this stabilization phase and the duration »tOff« of what defines a “long” outage are settable.

NOTICE!

This module requires an external power supply, and therefore cannot be used with a self-supplied WIC1.

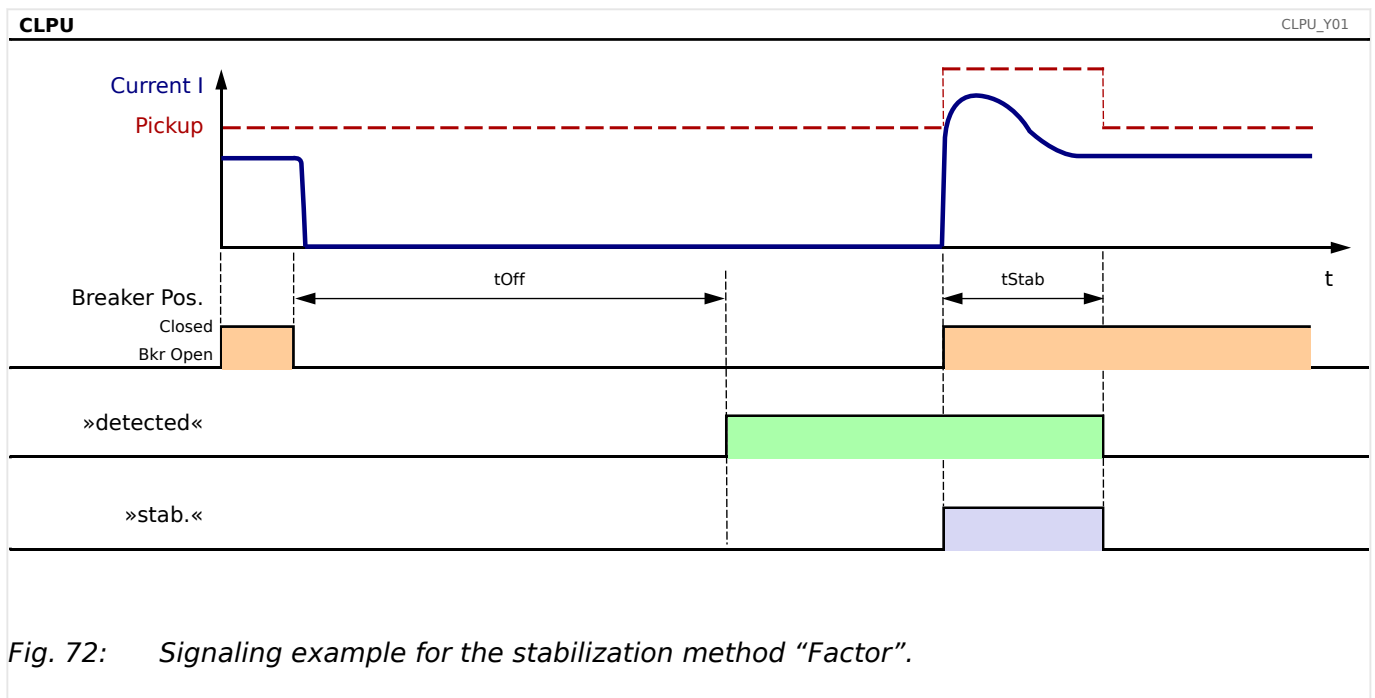

Fig. 72: Signaling example for the stabilization method “Factor”.

If the breaker position is detected as “open” the timer stage »tOff« is started. If the outage persists longer than »tOff«, the CLPU function is enabled so that temporary stabilization is started with the next re-energization (breaker position detected as “closed”). Then stabilization is carried out for the duration of »tStab«. Of course, »tStab« should be set according to the expected duration of the cold load current. The detection of the breaker position is described at →“Criteria for Determining the Switchgear Position”.

Please note that breaker position detection via the digital inputs has a delay (see ↪[10.1.10 Digital Inputs \(WIC1-4\)](#)). There may also be delayed indication of the position from the breaker itself. Therefore the time delay of the protection stages must be higher than the sum of these delays + a safety margin > 10 ms.

5.11.1 Functionality

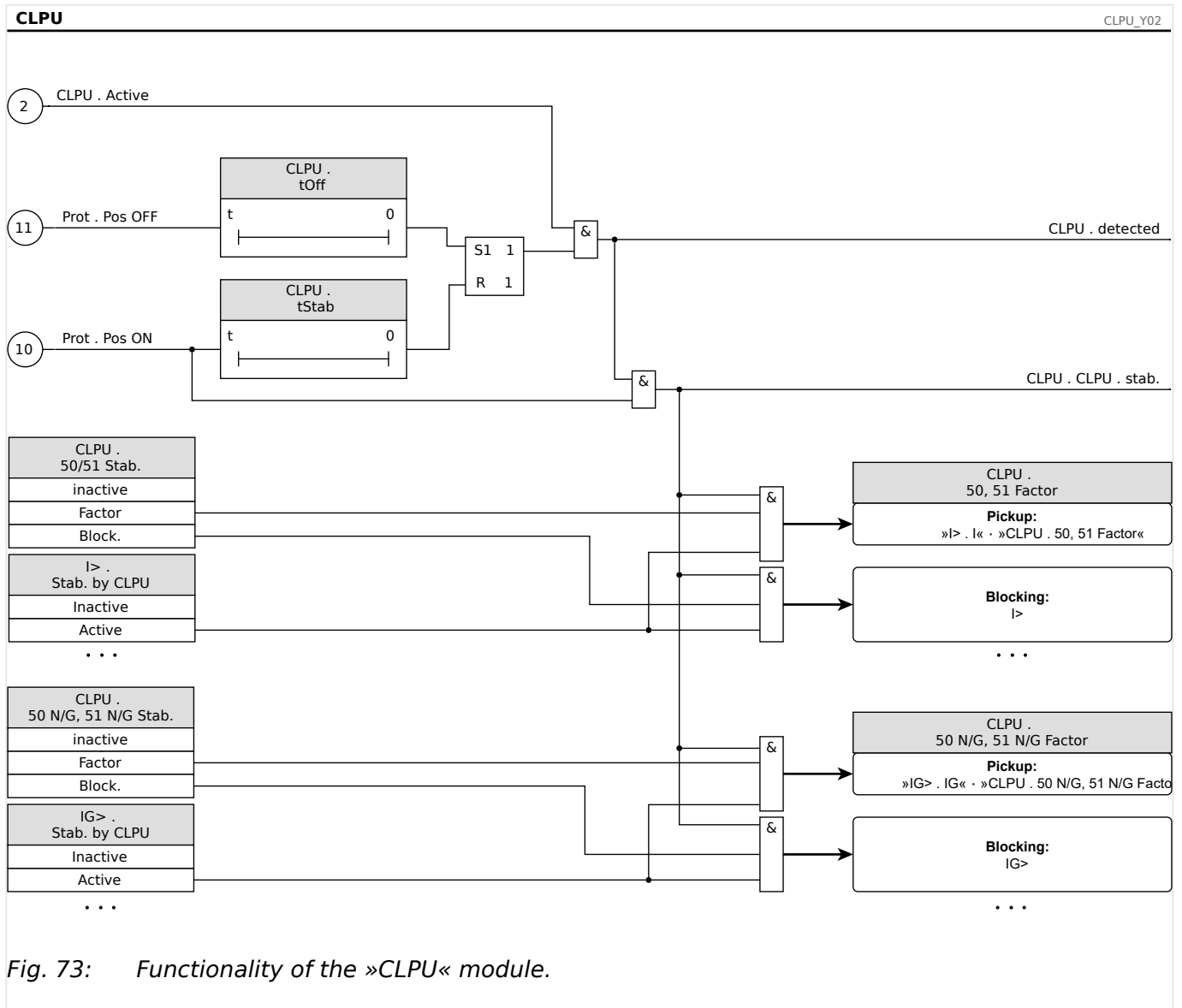

Fig. 73: Functionality of the »CLPU« module.

5.11.2 CLPU - Settings via Smart view (PC) or DiggIMEC

⚙️

1. ▷ Activate the »CLPU« **module**.
2. ▷ Specify the **operating mode** with respect to the phase and ground (earth) overcurrent stages:

- [Protection Para / CLPU] »CLPU . 50/51 Stab.«
 - [Protection Para / CLPU] »CLPU . 50 N/G, 51 N/G Stab.«
- Options:
- “Factor” — The pickup threshold will be temporarily increased.
 - “Block.” — The overcurrent stage will be blocked.

3. ▷ If the operating mode has been set to “Factor” then define the **factor** by which the threshold will be multiplied.
 - [Protection Para / CLPU] »CLPU . 50, 51 Factor«
 - [Protection Para / CLPU] »CLPU . 50 N/G, 51 N/G Factor«
4. ▷ Specify the **outage time** that characterizes a “long” outage.
 - [Protection Para / CLPU] »CLPU . tOff«
5. ▷ Specify the **stabilization time** by setting it to the expected duration of the cold load current.
 - [Protection Para / CLPU] »CLPU . tStab«
6. ▷ Within each (phase or ground) overcurrent stage that you want stabilized, enable the CLPU stabilization.
 - [Protection Para / I>] »I> . Stab. by CLPU« = “Active”
 - ...

5.12 ExP – External Protection

The external protection module »ExP« can be used to trip the circuit breaker and record the event or alarm in case of any external event (e. g. sudden pressure, oil level, inter-tripping).

An external signal, that has been assigned to a Digital Input, is monitored, and (with some WIC1 variants) there is the option to make this dependent on another “condition” signal. The »ExP« module picks up if this external signal (or these two signals) become(s) active.

The availability and number of Digital Inputs, however, depends on the WIC1 variant. For the sake of simplicity, there is the following general concept for all WIC1 variants:

- There is always one protection stage, »ExP[1]«, active, and the »ExP[1]« trigger is pre-defined and set to DI2.

(Trivial exception: Device variants WIC1-#xxxxxNxxxx without any Digital Input, where there is (obviously) no »ExP« available.)

- For WIC1 variants with configurable Digital Inputs, this setting is a default that can be changed.
- For WIC1 variants with 2 Digital Inputs, there is also a second protection stage »ExP[2]«, but it is deactivated by default. (Use Smart view (PC) / DiggiMEC for activation)

For »ExP[2]« (if available), the user can select between two operating modes:

- Unconditional — The »ExP[2]« module trips if this external signal is triggered.
- Conditional — The »ExP[2]« module trips if this external signal is triggered and - at the same time - a “condition” signal, that has been assigned to the parameter »Condition«, is active.

For »ExP[1]«, the operating Mode is always unconditional.

5.12.1 Functionality

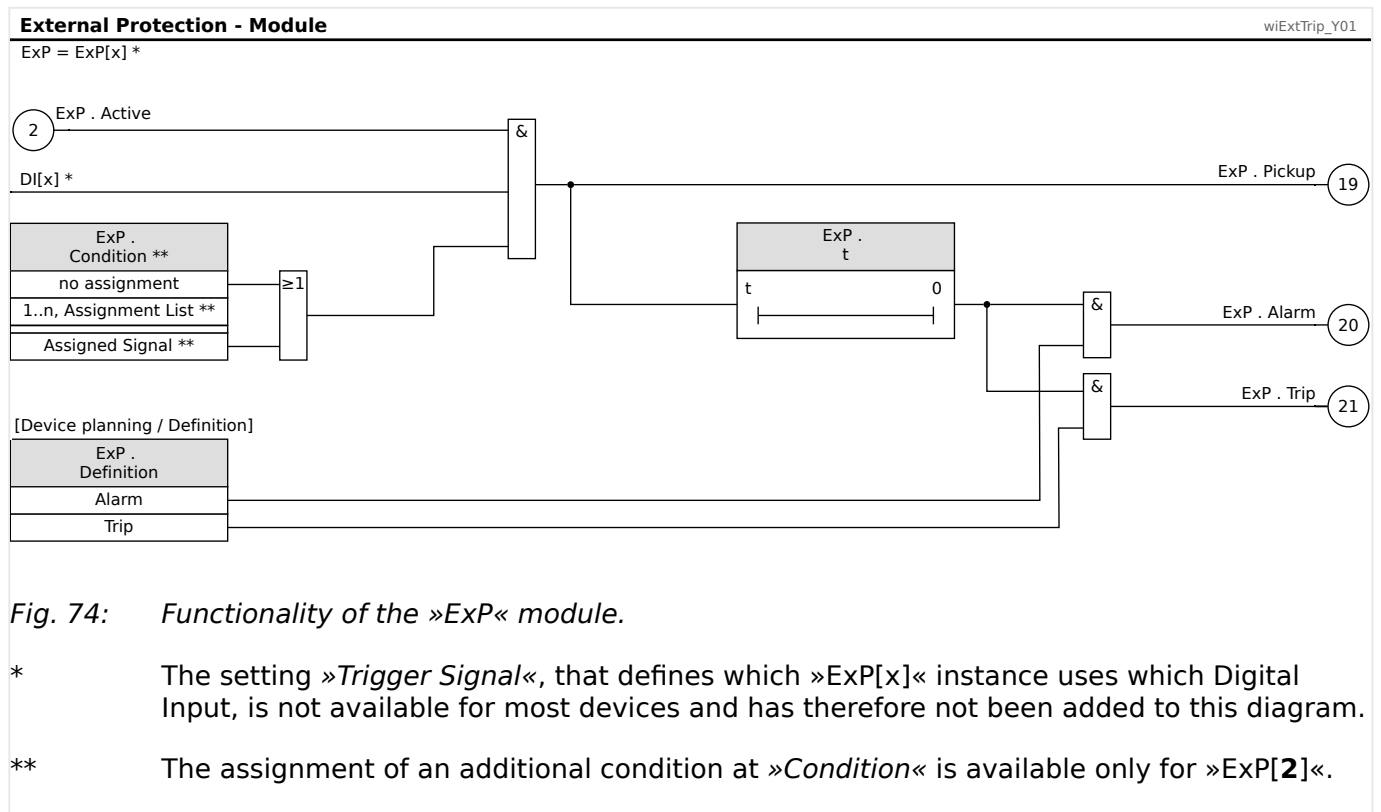

5.12.2 External Protection - Settings via Smart view (PC) or DiggiMEC

⚙️	
1.	▷ Activate the protection stage and select whether it shall operate as a supervision or a protection function, see ↪5.1 »Prot« - General Protection Module .
2.	▷ For device variants with configurable digital inputs, select the trigger signal , i. e. the external signal. <ul style="list-style-type: none"> • [Protection Para / ExP[1]] »Trigger Signal« Even if there is any choice available, you might usually want to keep the default "Prot . DI x".
3.	▷ Select the condition (only for »Exp[2]«), that needs to be fulfilled in addition to the external signal: <ul style="list-style-type: none"> • [Protection Para / ExP[1]] »Condition« = Options: <ul style="list-style-type: none"> ◦ "-" — no condition, i. e. the »Exp[x]« module picks up as soon as the external signal gets active. ◦ Or you select a particular signal, that you require to be active in addition to the external signal.
4.	▷ Specify the tripping delay (in seconds): <ul style="list-style-type: none"> • [Protection Para / ExP[1]] »Exp[1] . t«
5.	▷ And of course, on the hardware side, the respective Digital Input must be wired as required.

5.13 CBF - Circuit Breaker Failure [50BF, 62BF]

5.13.1 Principle - General Use

The »CBF« module is used to provide backup protection in the event that a breaker fails to operate properly during fault clearing. This signal is to be used to trip the upstream breaker (e.g. infeed of a busbar) either via an output relay or via Communication (SCADA).

The WIC1 detects a breaker failure based on the measured phase currents (ANSI/IEEE C37.2 50BF) and/or on the position indicators of the breaker (ANSI/IEEE C37.2 62BF - if supported by the WIC1 variant).

- A supervision timer is started as soon as the »CBF« module is triggered by a trip signal. A Breaker Failure is detected and an alarm signal »CBF . Alarm« is issued if the breaker is not determined as "open" within the set time.
- The criteria that are used for determining the breaker state are described in [↪"Criteria for Determining the Switchgear Position"](#).

Trigger

- Prot . TripCmd — The Trip Command triggers the »CBF« module. (See [↪5.1 »Prot« - General Protection Module](#) and, in particular, the signal (52) in [↪Fig. 49.](#))

Start/Trigger of the CBF Timer

The setting [Protection Para / CBF] »CBF . t-CBF« defines a supervision time: The timer is started once the CBF module is triggered. Even if the trigger signal drops again, this timer continues. If the timer elapses (before it gets stopped by the breaker having successfully opened), the »CBF« module issues an alarm. This alarm signal is to be used to trip the upstream breaker (backup).

NOTICE!



In order to prevent a faulty alarm of the »CBF« Module, the supervision time »CBF . t-CBF« must be greater than the sum of:

- Operating time of the WIC1
- + The close-open time of the breaker (please refer to the technical data of the manufacturer of the breaker)
- + Drop off time (current- or position indicators)
- + Security margin.

5.13.2 States / Standby

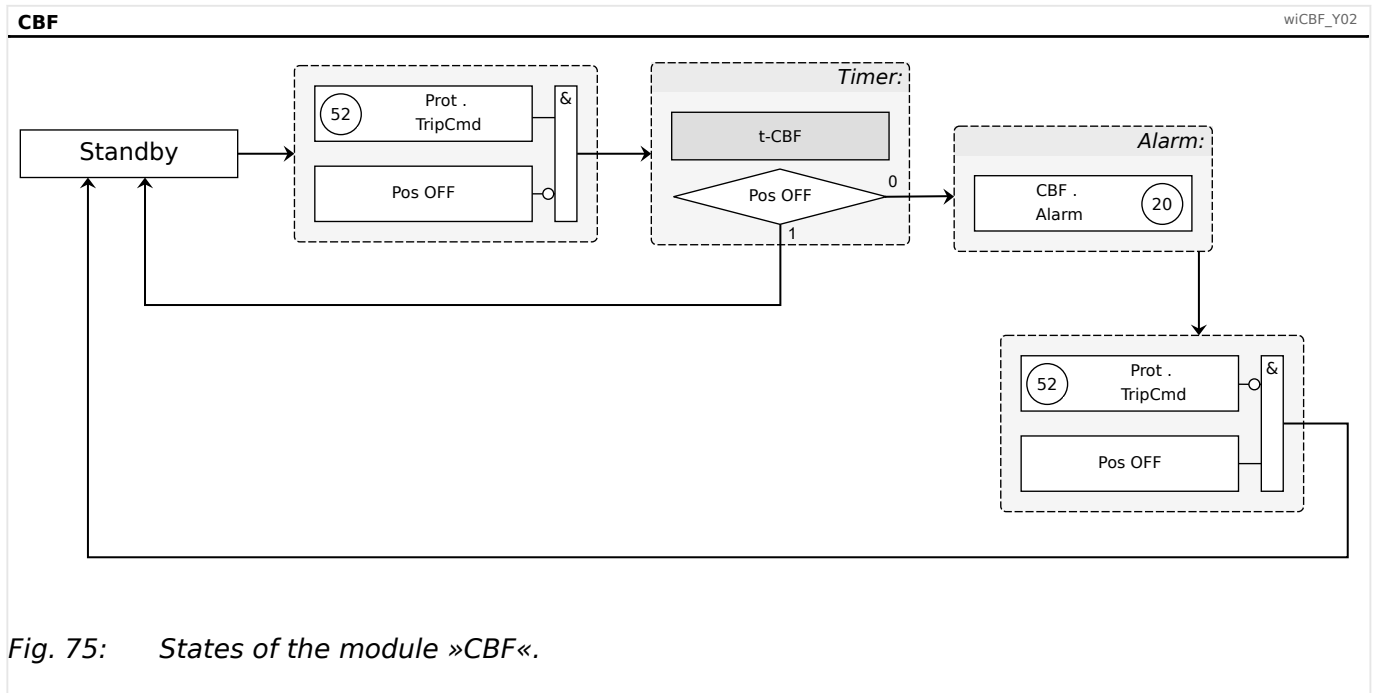

Fig. 75: States of the module »CBF«.

The »t-CBF« timer is stopped if the opening of the breaker is detected before the timer has elapsed.

After the timer has elapsed, however, the »CBF« module has already entered the “Alarm” state. This state is only left if the trigger signal, i. e. the Trip Command signal, drops off **and** the opening of the breaker is detected. (See also the state diagram →Fig. 75.)

5.13.3 Functionality

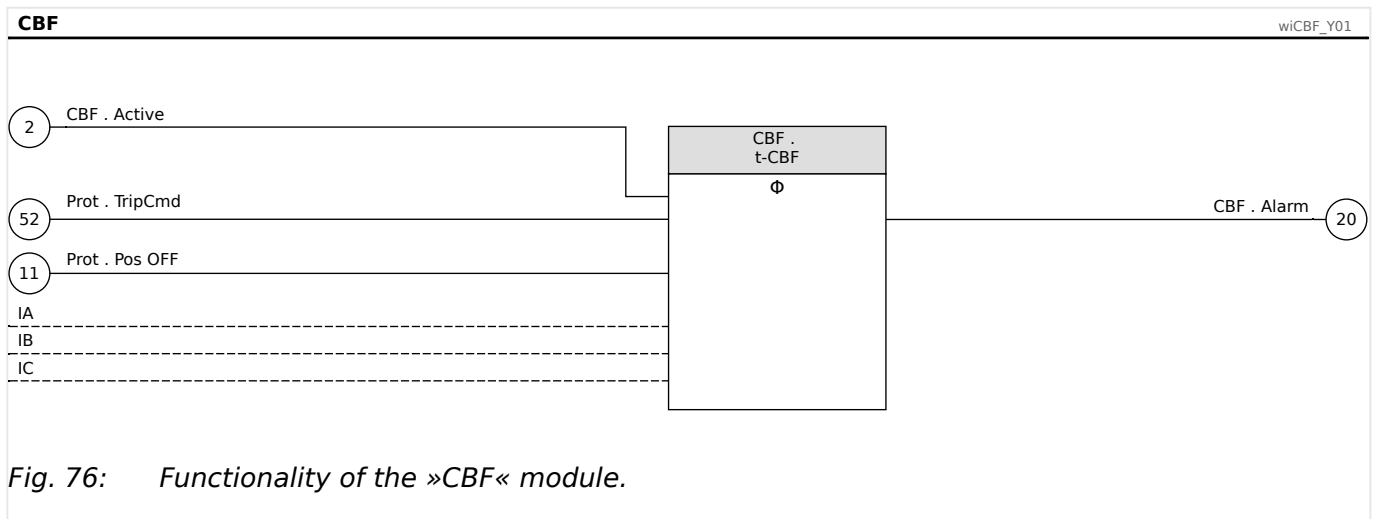

Fig. 76: Functionality of the »CBF« module.

5.14 Supervision

5.14.1 BkrWear

Circuit breakers are often maintained based on a fixed time interval. These time intervals can be increased if more sophisticated operation data are available.

The »BkrWear« module monitors the number of trips and the interrupted currents. These data can be used to determine the breaker wear and to plan maintenance intervals.

Counters

- The magnitude of the interrupted currents is the maximum measured current in all phases from start of the trip pulse until clearance.

(Note, however, that current measurements have a limited measuring range: If a short circuit current exceeds this range it will not be registered with its full magnitude, and this will affect the current-based decisions of the »BkrWear« module.)

The value for the sum of interrupted currents can be accessed at [Operation / Condition Monitoring / BkrWear] »*BkrWear . Sum Itrip*«.

- The number of trip operations is counted.

The counter value can be accessed at [Operation / Condition Monitoring / BkrWear] »*BkrWear . Sum Trips*«.

Wear Level Characteristic

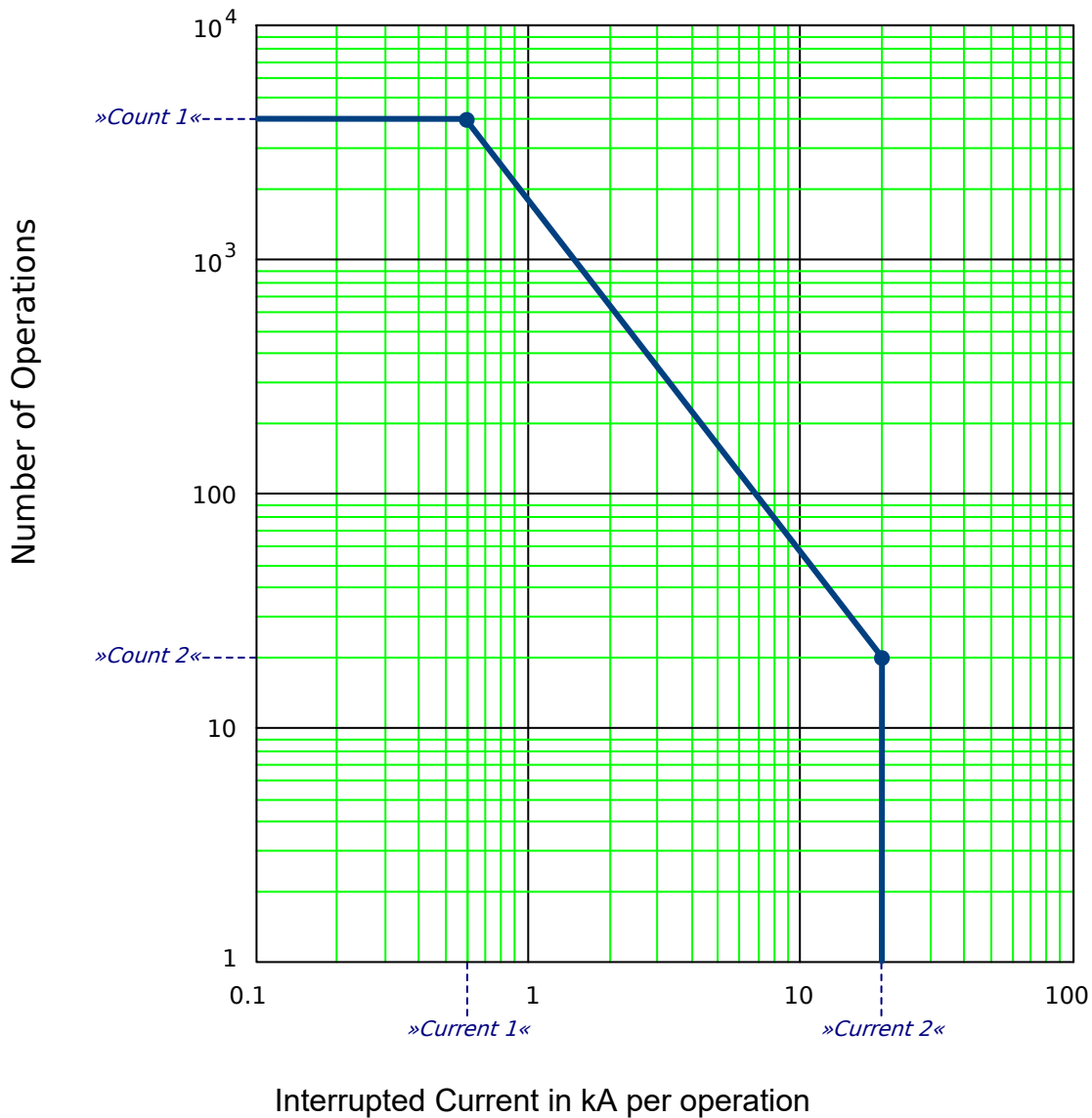

wiCBM_Z67

Fig. 77: Wear curve, as it can be defined within the »BkrWear« module.

The wear level of the breaker is calculated based on the number of trips and the sum of interrupted currents. The calculated wear level helps to determine necessary maintenance of the breaker.

The »BkrWear« module supports the definition of two points on the curve. For currents between these thresholds there is a logarithmic interpolation to calculate the wear progress.

The two points on the curve are a characteristic property of the connected circuit breaker and are therefore usually supplied by the manufacturer. The setting parameters at the WIC1 are as follows:

- Point 1 is the rated current of the circuit breaker and the maximum allowed number of switching operations at the rated current.
 - [Protection Para / Condition Monitoring / BkrWear] »BkrWear . Ir«

- [Protection Para / Condition Monitoring / BkrWear] »BkrWear . N(Ir)«
- Point 2 is the max. short-circuit current and the maximum allowed number of switching operations at this max. short-circuit current.
 - [Protection Para / Condition Monitoring / BkrWear] »BkrWear . Isc«
 - [Protection Para / Condition Monitoring / BkrWear] »BkrWear . N(Isc)«

CAUTION!

The curve is only correctly defined if the following conditions are fulfilled:

- »BkrWear . Isc« > »BkrWear . Ir«
- »BkrWear . N(Isc)« > »BkrWear . N(Ir)«

Otherwise the wear level feature will remain inactive.

- The value for the wear level is a percentage and can be accessed at [Operation / Condition Monitoring / BkrWear] »BkrWear . Bkr Wear Level«.

If it reaches 100 % the circuit breaker urgently needs maintenance.

5.14.1.1 BkrWear - Settings via Smart view (PC) or DiggIMEC

1. ▷ Specify whether the »BkrWear« module shall monitor only the counter values, or the counters together with the calculated wear level:
 - [Device planning / Projected Elements] »BkrWear . Mode« =
Options:
 - “Counters only” — only the counter values are monitored.
 - “Counters, Wear Lev.” — counter values and wear level are monitored.
2. ▷ Set the maximum counter value for the number of trips:
 - [Protection Para / Condition Monitoring / BkrWear] »BkrWear . Alarm Thresh. Sum Trips«
3. ▷ Set the maximum value for the sum of interrupted currents:
 - [Protection Para / Condition Monitoring / BkrWear] »BkrWear . Alarm Thresh. Sum Itrip«
4. ▷ If the wear level shall be used set the maximum value for it:
 - [Protection Para / Condition Monitoring / BkrWear] »BkrWear . Max. CB Wear Level« - as a percentage value from 50% to 100%.
5. ▷ Make sure that the rated primary current is correctly set at [Field Para / CT] »CT pri«, see [↪5.2.1 Field Parameter Settings via Smart view \(PC\) or DiggIMEC](#).
Only then can the »BkrWear« module be set active:

- [Protection Para / Condition Monitoring / BkrWear] »*BkrWear . Function*« = "Active"

If the maximum number of trips is exceeded the signal »*BkrWear . Alm(mx.Sum.Tr)*« is issued.

If the maximum for the interrupted currents is exceeded the signal »*BkrWear . Alm(mx.Sum.Itrip)*« is issued.

If the threshold for the wear level is exceeded the signal »*BkrWear . Alm (CB Wear Lev.)*« is issued.

If any of the maximum values is exceeded the alarm message »*BkrWear . Alarm*« is issued, and it is recommended to maintain the breaker.

Following the maintenance, all values (counters and wear level) can be reset using the Direct Command [Operation / Reset] »*BkrWear . Reset*«.

5.14.1.2 Functionality

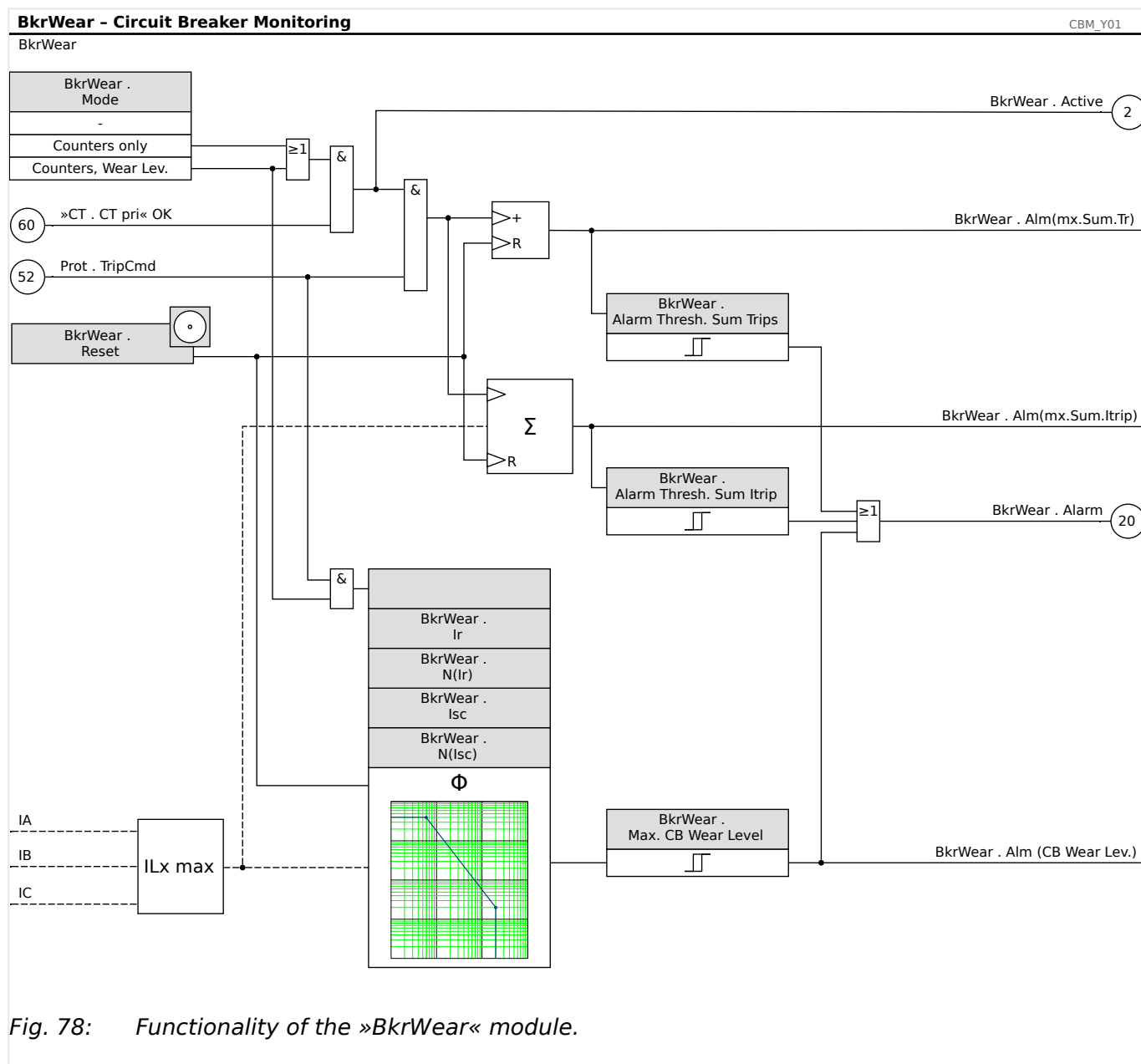

5.14.2 »TCM« – Trip Circuit Monitoring [74TC]

The trip circuit monitoring is used for monitoring if the trip circuit is ready for operations.

The WIC1 module »TCM« monitors the trip circuit based on internal measurements if it is permanently supplied with sufficient energy (↔2.3 Supply of a WIC1). If an interrupt is detected an alarm signal is issued after the (internally fixed) delay of 10 seconds.

There are trip coils with a trip circuit that gets automatically disconnected by an (internal or external) circuitry. This, however, can lead to an unwanted alarm of the »TCM« module because its internal measurements detect the disconnection. Therefore, the »TCM« can only be used with such a trip circuit if an additional blocking is configured that blocks the »TCM« whenever the circuit breaker has opened. Such a setting can be made by assigning an appropriate blocking signal - a digital input or the detected "breaker open" position (see ↔5.1.4.2 Switchgear Position) - to [Protection Para / TCM] »TCM . ExBlo«.

The signal [Operation / Status Display / Alarms] »TCM . Alarm« can be assigned to Outputs and LEDs (see also ↔3.10.3 Impulse Signal for the Flag Indicator) or DiggiMEC LEDs / Output Relays).

Remark: For some devices variants the Flag Indicator "FI" is used as a Self-Supervision Alarm output. Therefore, it is not possible to assign a Trip or other signals in this case. Nevertheless, TCM still can be used by setting [Device Para / WIC1 / Output] »Prot . TCM« = "Active". See also ↔2.6.1 Order Forms and ↔7.3 Backup Protection / Self-Supervision for more information on these device variants.

5.14.3 Condition Monitoring – Life Load

The WIC1 evaluates the operating time in dependency on the phase current flow. This allows for checking whether the WIC1 – and therefore the protected object as well – have been frequently under high load.

The WIC1 divides the current measuring range into (fixed) intervals. For each interval, the operating time is measured as long as the maximum RMS value of the three phase currents is within this interval. These data are permanently kept updated, beginning with the first WIC1 start. Only in case of a [factory reset](#) or a firmware update will the statistics be reset.

The data collection even continues if the »Life Load . Mode« parameter is set to inactive in the [Device planning / Projected Elements], only the evaluation and display of this statistic then stops.

There are two menu items to access the resulting statistic:

- [Operation / Condition Monitoring / Life Load (Values)] – Numerical values are shown in tabular form.
- [Operation / Condition Monitoring / Life Load] – The values are shown as a graphical histogram.

(The data are always displayed using “days” as unit, but of course, the internal evaluation is carried out with better precision.)

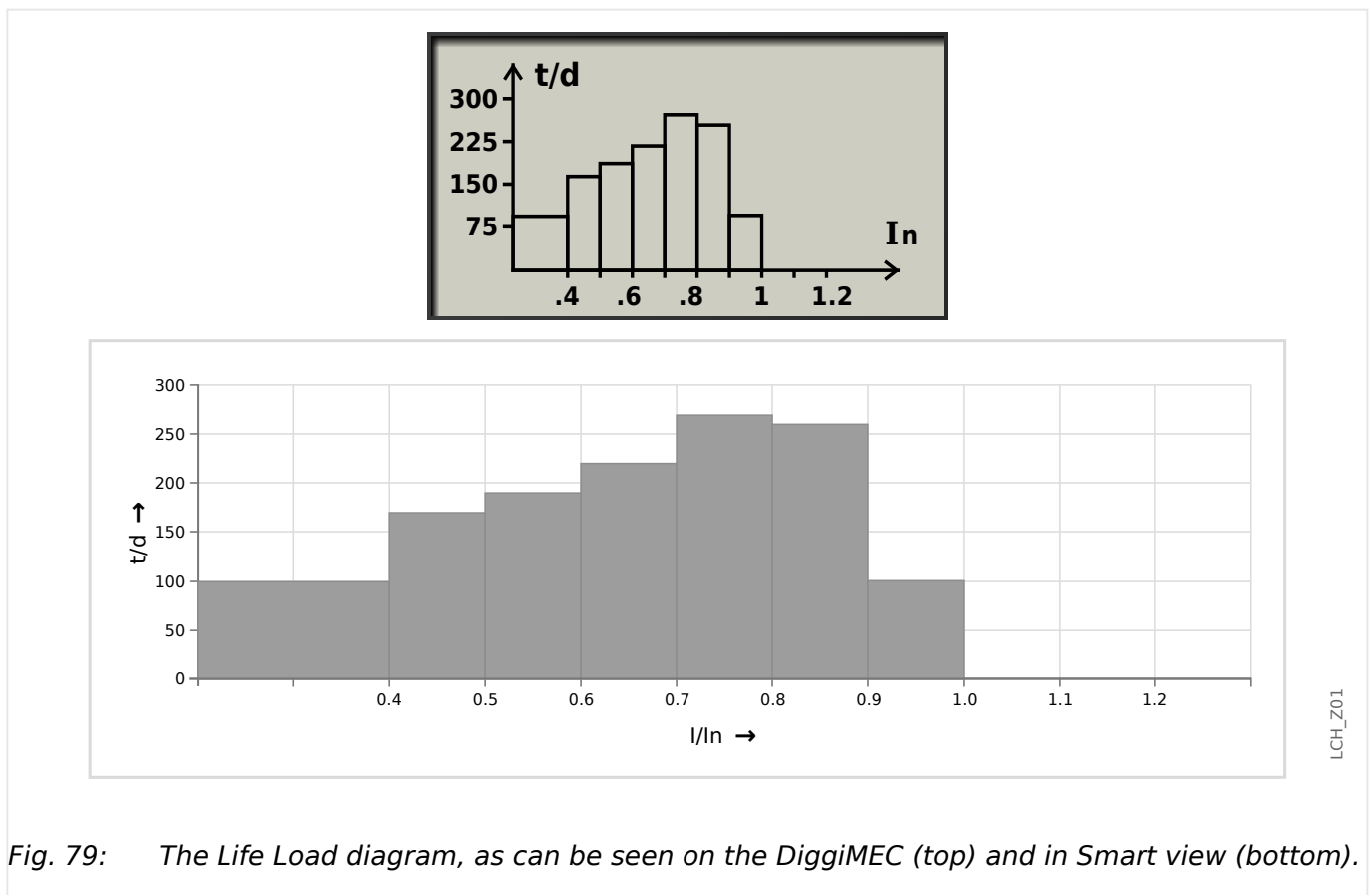

Fig. 79: The Life Load diagram, as can be seen on the DiggiMEC (top) and in Smart view (bottom).

Note that for a self-supplied WIC1, the first interval “< 0.4 In” is influenced by the fact that the WIC1 cannot measure any operating times if the phase current is too low. (An externally supplied WIC1-4, however, evaluates also small phase currents, provided that the breaker position is determined as “closed” – according to the criteria described in [↪“Criteria for Determining the Switchgear Position”](#).)

Alarm Signal

The »Life Load« module can (optionally) issue an alarm signal if the WIC1 has been running with too high load for a particular time.

The following settings are available for this:

- [Protection Para / Condition Monitoring / Life Load] »/« - This is the current threshold, above which the alarm might be issued (depending on the set time threshold).
- [Protection Para / Condition Monitoring / Life Load] »Threshold t« - This is the time threshold.

All operating times for the intervals above the current threshold are summed up, and if this sum is above the setting for the time threshold then the alarm signal »Life Load . Alarm« is issued.

- [Operation / Condition Monitoring / Life Load (Values)] »Time to Alarm« - This is the time left until the alarm signal is issued. This value counts backwards from its initial value »Threshold t« to 0.
- [Operation / Reset] »Life Load . Rst. Alarm« - Direct command to reset the alarm signal. The value of »Time to Alarm« also gets reset to its initial value »Threshold t«.

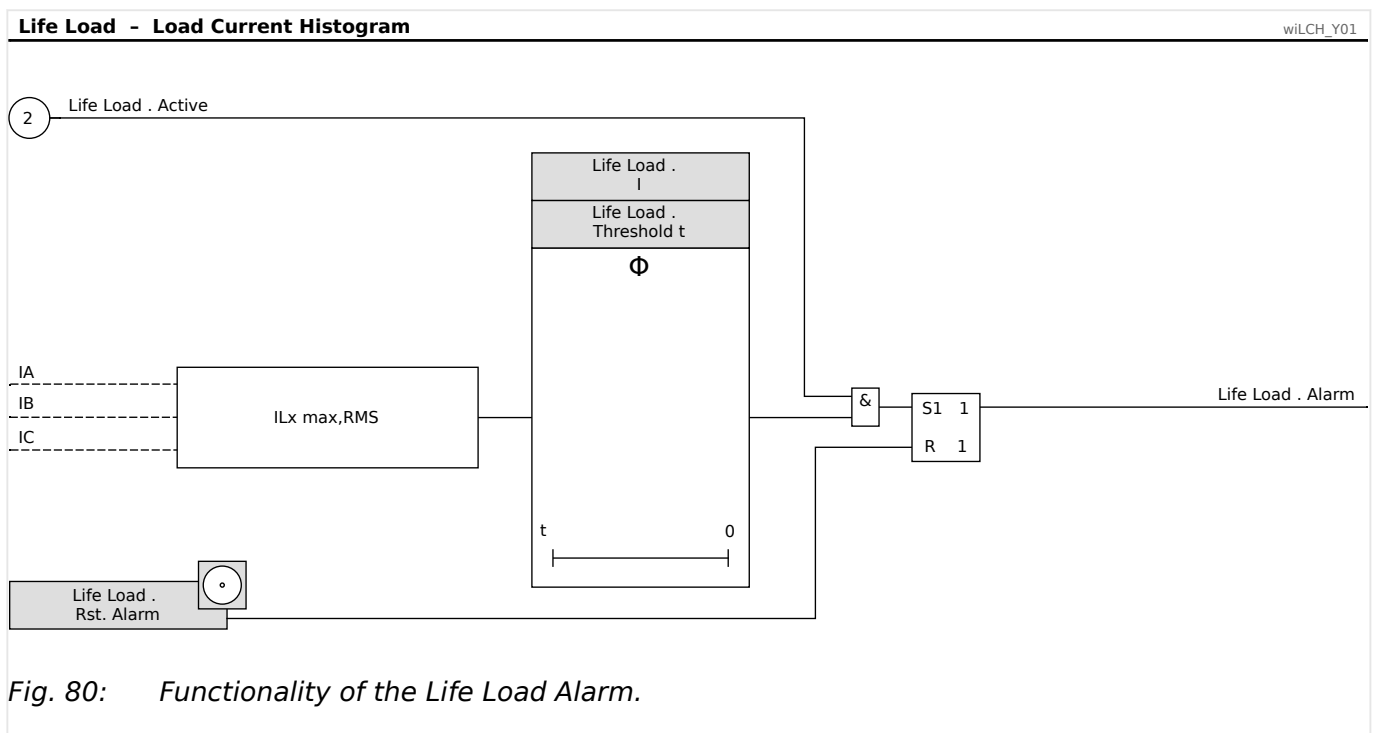

Fig. 80: Functionality of the Life Load Alarm.

5.14.4 Condition Monitoring – Peak Current Pointer

The »Peak Current Ptr« mimics an analog pointer instrument by calculating a time-average of the maximum phase current. This allows for checking whether the WIC1 – and therefore the protected object as well – have been under high load.

The resulting values can be checked at these menu items:

- [Operation / Condition Monitoring / Peak Current Ptr (Values)] – Numerical values are shown in tabular form.
- [Operation / Condition Monitoring / Peak Current Ptr] – The values are shown as a diagram. The diagram design is inspired by an analog pointer instrument.

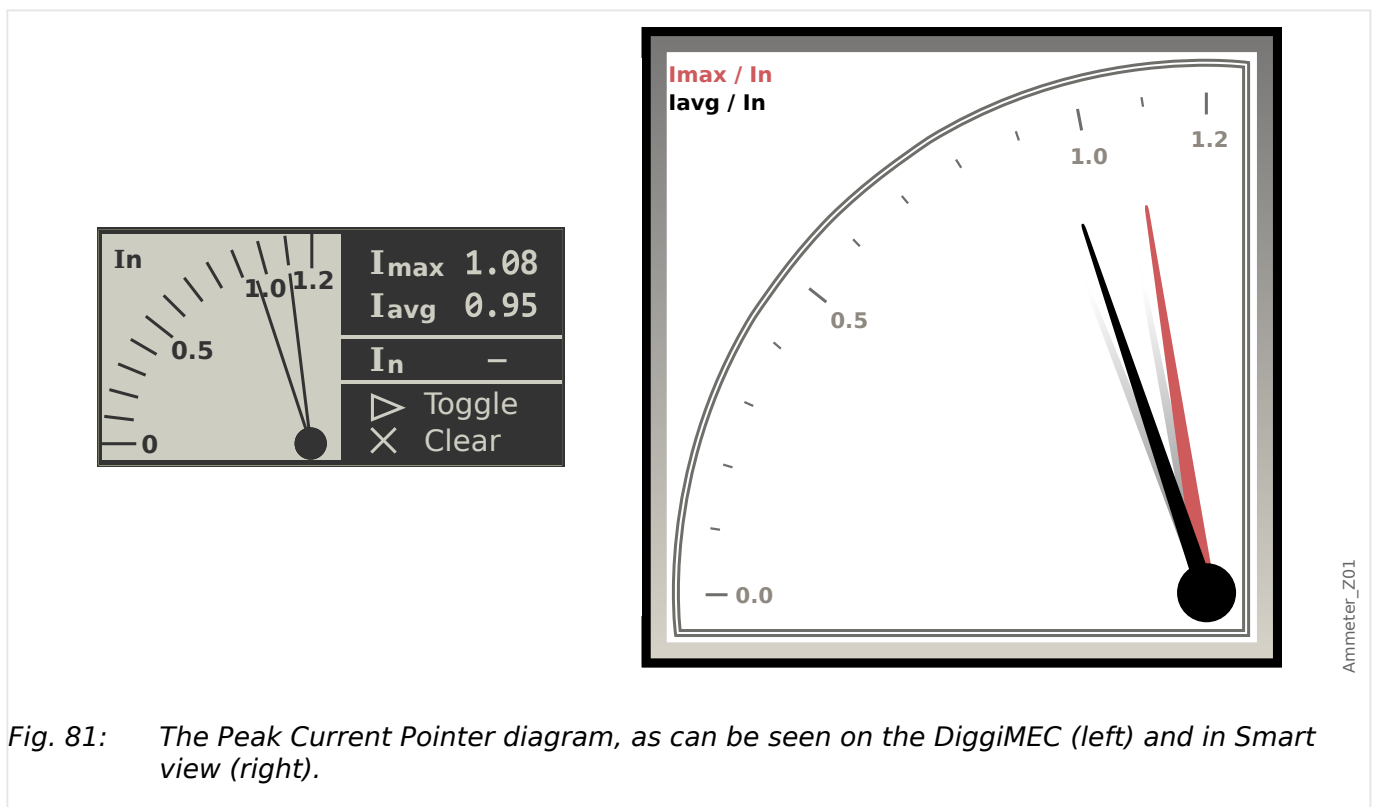

Fig. 81: The Peak Current Pointer diagram, as can be seen on the DiggiMEC (left) and in Smart view (right).

The following values are shown:

- » I_{avg} « – the average of the maximum RMS values of the three phase currents, averaged over the selected time window »*Time win. for calc. avg.*«.

Note that the average value is invalid for some time after a restart of the WIC1 and after a reset. Only after the selected time window has elapsed will the average » I_{avg} « become valid.

- » I_{max} « – the maximum value of the average » I_{avg} « since the last manual reset.

The time window for calculating the average value » I_{avg} « is set here:

- [Protection Para / Condition Monitoring / Peak Current Ptr] »*Time win. for calc. avg.*«

A manual reset of the » I_{max} « maximum value can be carried out either at the DiggiMEC by pressing the »✕« key, or via this Direct Command:

- [Operation / Reset] »*Clear*«

5.14.5 Condition Monitoring - Station Battery Monitoring (WIC1-4 only*)

* This function monitors the external power supply, and therefore it is available only for WIC1-4 devices.

The module SBM monitors the applied station battery voltage (i. e. the auxiliary voltage). The voltage measurements and statistics can be viewed at the [Operation / Condition Monitoring / SBM] menu, and the Direct Command [Operation / Reset] »SBM . Rst. Statistics« allows for resetting the battery statistics. (A detailed list can be found in the Reference Manual.)

Another Direct Command [Protection Para / Condition Monitoring / SBM] »SBM . Corr.factor Vbatt« allows for manually defining a correction factor as a percentage. If, for instance, the actual voltage of the station battery is 23.9 V, but the displayed voltage is »V Batt« = 23.4 V, then this deviation can optionally be corrected by this setting: »Corr.factor Vbatt« = $(23.9 - 23.4)/23.4 = +2.1\%$

Alarm / Trip

If the voltage exceeds a settable threshold, or drops below some other threshold then alarm signals are issued. If the voltage drops below some other, even smaller, threshold then the WIC1-4 can either issue a dedicated alarm signal or trip the circuit breaker, depending on the settings.

5.14.5.1 Alarm/Trip Functionality of the SBM module

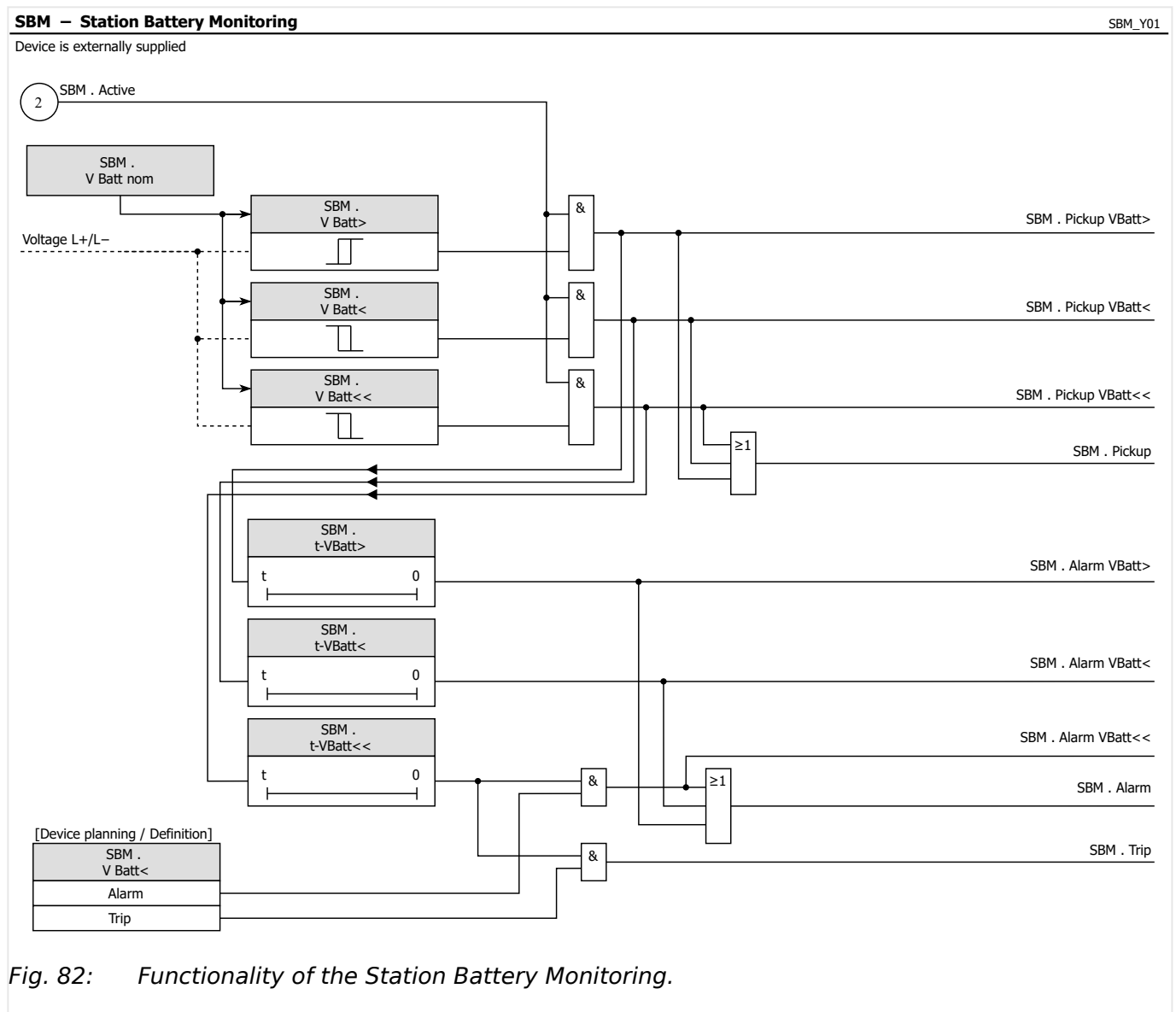

Fig. 82: Functionality of the Station Battery Monitoring.

6 Fault/Alarm Recorder

General Functionality

The *Fault/Alarm Recorder* provides information about alarms and faults.

If a DiggiMEC is connected when the event (fault or alarm) happens, a pop-up window is sent onto the display in order to draw the user's attention to the event. (See [↪6.1 Fault/Alarm Display](#).) This might be helpful for fast fault analysis.

Further details for an analysis can then be made either directly at the DiggiMEC or - after connecting a PC - by means of *Smart view*.

Every protection function can be configured either as »*Definition*« = "Alarm" or as »*Definition*« = "Trip" (see [↪"Definition \("Alarm ↔ Trip"\) of a Protection Function"](#)). Corresponding to this classification, the Fault/Alarm Recorder keeps two independent counters, »Alarm No.« and »Fault No.«, as the running alarm number or trip number. When checking the Fault/Alarm Recorder with DiggiMEC or *Smart view*, all previous alarms and trips are shown in one common table (with »Alarm No.« and »Fault No.« in separate table columns) so that an immediate overview of what has happened is possible. (See also [↪6.1 Fault/Alarm Display](#).)

Times and Durations

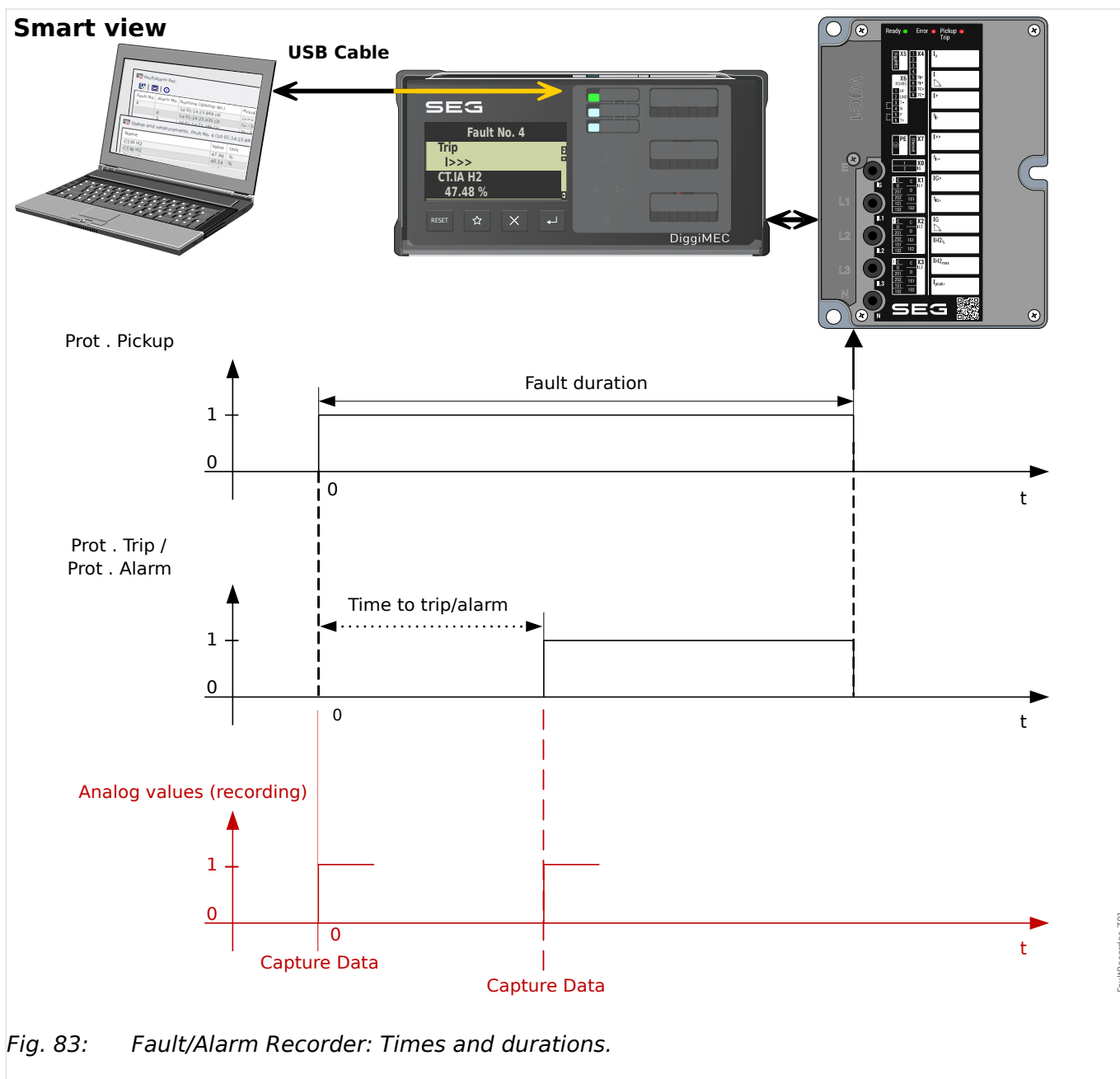

Fig. 83: Fault/Alarm Recorder: Times and durations.

Behavior

The Fault/Alarm Recorder is triggered by the rising edge of the »Prot . Pickup« (General Pickup) signal, see →5.1 »Prot« - General Protection Module.

If the protection function is configured as »Definition« = "Alarm" (see →"Definition ("Alarm ↔ Trip") of a Protection Function") the counter »Alarm No.« gets incremented, if the protection function is configured as »Definition« = "Trip" the counter »Fault No.« gets incremented.

Measurement values at the time of the Pickup get captured and recorded. If the (General) Pickup is followed by a (general) Trip (signal »Prot . Trip«) - or by an Alarm (signal »Prot . Alarm«) - then the Fault/Alarm Recorder updates all data. In this case all values describe the situation at the moment of the trip/alarm.

6.1 Fault/Alarm Display

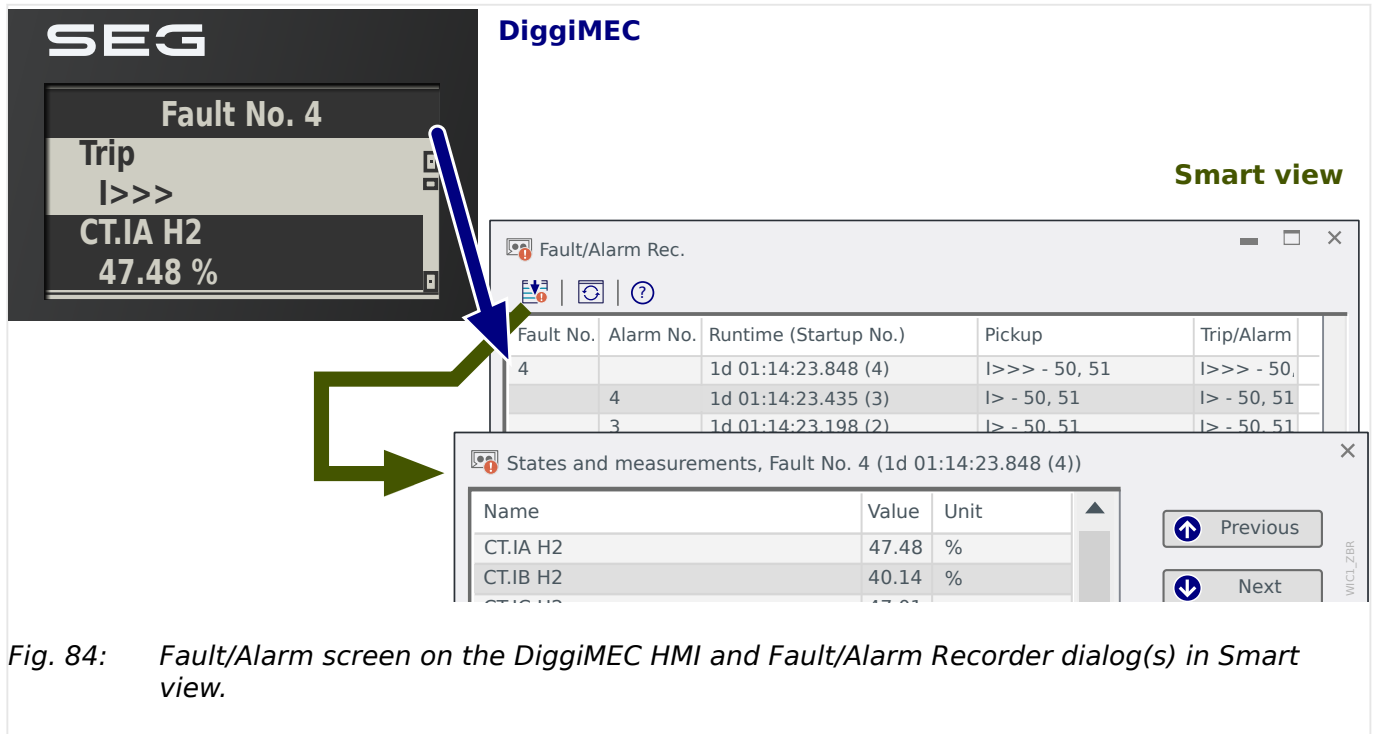

Fig. 84: Fault/Alarm screen on the DiggiMEC HMI and Fault/Alarm Recorder dialog(s) in Smart view.

All fault/alarm records are saved in a power-fail-safe manner. The table of recorded events can be accessed at any time by entering the menu [Operation / Recorders / Fault/Alarm Rec.].

If there is no more memory free, the oldest record will be overwritten (FIFO). Up to 10 faults and up to 3 alarms can be stored. The Direct Command [Operation / Reset] »Rst. Alm/Flt Rec.« can be used to delete all (fault and alarm) records immediately.

A Fault Display screen appears on the DiggiMEC display when the General Pickup drops off and it gets updated with every new pickup/trip/alarm signal. As a consequence, the Pop-up screen always shows the last pickup/trip/alarm event.

By pressing the »↵« key ("OK") the overlay/pop-up is closed, but will re-appear with the next restart. Press the »Reset« key or use the Direct Control »Rst. LEDs, Fls« to close it permanently.

CAUTION!



There is no real-time clock available with the WIC1. Therefore each Fault Record is labeled with a relative time. This relative system time specifies the uptime of the WIC1, that is the duration since the last (warm or cold) restart.

In addition, the total number of WIC1 restarts is also shown. (Smart view: as a number in parentheses; DiggiMEC: as a separate "Startup No" value.)

NOTICE!

Please note: The parameter settings (thresholds, etc.) that are shown in a fault record are not part of the fault record itself. They are always read out from the current device setting. If it may be the case that the parameter settings shown in a fault record were updated, they are indicated with an asterisk symbol within the fault record.

To prevent this please proceed as follows:

Save any fault record that should be archived to your local network/hard disk before doing any parameter change. Delete all the fault records in your fault recorder afterwards.

6.2 Content of a Fault/Alarm Record

A fault/alarm record comprises information about:

Part 1: Common Information (independent of protection function)	
Fault No.	This counter will be incremented with each pickup of a protection function that is configured as » <i>Definition</i> « = "Trip".
Alarm No.	This counter will be incremented with each pickup of a protection function that is configured as » <i>Definition</i> « = "Alarm".
Runtime (Startup No.)	Timestamp of the Fault. This specifies the uptime of the WIC1, and the total number of WIC1 restarts (in parentheses). Example: 1d 01:14:23.848 (4) — The fault occurred at 1 day, 1 hour, 14 minutes, 23.848 seconds after the 4 th restart. (Restarts counted from WIC1 delivery.)
Time to trip/alarm	The time between the first detected pickup and the first detected trip/ alarm (independent of how many protection modules are involved). This means the pickup signal that triggers the Fault/Alarm Recorder can be issued by another protection module than the trip/alarm signal.
Pickup, issued by:	Name of the module / protection stage that picked up first.
Trip/Alarm, issued by:	Name of the module / protection stage that first issued a trip (or alarm) signal.
Part 2: Information depending on the active settings	
States and measurements	Various measuring values and states at the time of the pickup or trip/ alarm are displayed.

6.3 How to Read Out the Fault Recorder at the DiggIMEC Panel

In order to read out a fault record there are two options available:

- Option 1: A Fault has popped up on the DiggIMEC display (because a trip or pickup has occurred).
- Option 2: Call up the Fault Recorder menu manually.

Option 1 (in case a fault record pops up on the DiggIMEC display (overlay):

- Analyze the fault record by using keys “▲” and “▼”.
- Or close the Pop-up by using the »←« key.

Option 2:

- Enter the menu branch [Operation / Recorders / Fault rec], using either the DiggIMEC panel or Smart view.
- Select a fault record.

How to Navigate Within the Fault Recorder via DiggIMEC

Navigation within the Fault Recorder	Key
Back to overview.	◀
Next (upper) item within this fault record.	▲
Next (lower) item within this fault record.	▼

7 Self-Supervision

The protection devices apply various check routines during normal operation and during the start-up phase to supervise themselves for faulty operation.

Self-Supervision within the devices		
Supervision of...	Supervised by...	Action on detected issue...
Supervision of data consistency after an outage of the power supply (e. g. outage of the power supply while changing the parameter settings).	An internal logic detects corrupt data after an outage of the power supply.	If the data is corrupt, all software-based protection modules are stopped, and the device continues with the backup protection .
Parameter Setting (Device)	<i>Smart view</i> carries out plausibility checks to protect the parameter settings. (For the settings via DIP or HEX switches there is no need for any plausibility checks.)	A problem within the parameter configuration can be detected by means of plausibility checks. Detected implausibilities are highlighted by a question mark symbol on the DiggiMEC and within <i>Smart view</i> .
Quality of the power supply	A hardware circuit ensures that the device can only be used, if the CT-based power (or the external power supply, if available) is in the range specified by the technical data.	If the supply voltage is too low, the device does not start, or it stops operating. If the voltage is sufficient for the WIC1, but not enough for loading the capacitors of the trip impulse output, then the green "Ready" LED (DiggiMEC: "System" LED) ceases to shine.
Internal data of the device (memory load, internal resources, ...)	An internal module monitors the system utilization.	The module for the supervision of the system utilization initiates in case of a fatal error a reboot of the device. Some fault types are indicated via the System/Error LED, see ↪ "The »System« LED(s) - "Ready", "Error"™ ". (Please refer to ↪ 11 Troubleshooting .) The issue will be recorded as a system message.



An externally supplied WIC1-4 allows for connecting an external output relay that operates as a "Healthy" / self-supervision contact. See ↪[3.10.1 Self-Supervision Contact for the WIC1-4](#).

7.1 Device Start (Reboot)

The WIC1 starts (or reboots) in any of the following situations:

- It is connected to the supply voltage (or gets sufficient electrical energy from the CTs),
- the user initiates (intentionally) a restart of the device,
- the device is set back to factory defaults,
- the internal self-supervision of the device detects a fatal error.

Note that every WIC1 restart also triggers a DiggiMEC restart, if connected. If a PC with Smart view is connected, then the connection is lost. To reconnect, close the previous session in Smart view (menu item [File / Close]), then select [Device / Receive Data from Device].

Every restart of the WIC1 – except for a normal start-up – appears as a new entry within the Self-Supervision messages, [↔7.2 Self-Supervision Messages](#).

The reason for a device start/reboot is shown numerically as “Value”. The value “1” in the example above means a normal start-up. Please see the table below for a full list.

Device Start-up Codes	
1.	Normal Start-up Start-up as a normal cold restart.
2.	Reboot by the Operator Device reboot triggered by the operator via HMI or <i>Smart view</i> .
3.	Forced Reboot (initiated by the WIC1 processor) The WIC1 processor identified invalid conditions or data.
4.	Illegal Memory Access Reboot after illegal memory access.
5.	Exceeded Time Limit of the Protection Cycle Unexpected interruption of the Protection Cycle.
6.	Sags of Power Supply Reboot after short-term sag or outage of the supply voltage / current via CTs.
12.	Reset to Factory Defaults Restart that is carried out due to reset to factory defaults. (See also ↔2.12 Reset to Factory Defaults .)
13.	Return from Backup Protection into normal operation After a transition into the operating mode “Backup Protection”, the WIC1 returns to normal operation after approx. 10 seconds via an automatic restart. (See also ↔7.3.1 Activation of the Backup Protection / Self-Supervision Mode .)

7.2 Self-Supervision Messages

Enter [Operation / Self-Supervision / Messages] to access the list of Self-Supervision messages. In particular, it is recommended to check these in case of some problem with respect to the WIC1 functionality.

The Self-Supervision collects various security-related messages (e. g. restarts or setting changes) and WIC1-internal status messages, warnings and error messages.

All Self-Supervision messages that can potentially appear are described here: [↪11 Troubleshooting](#).

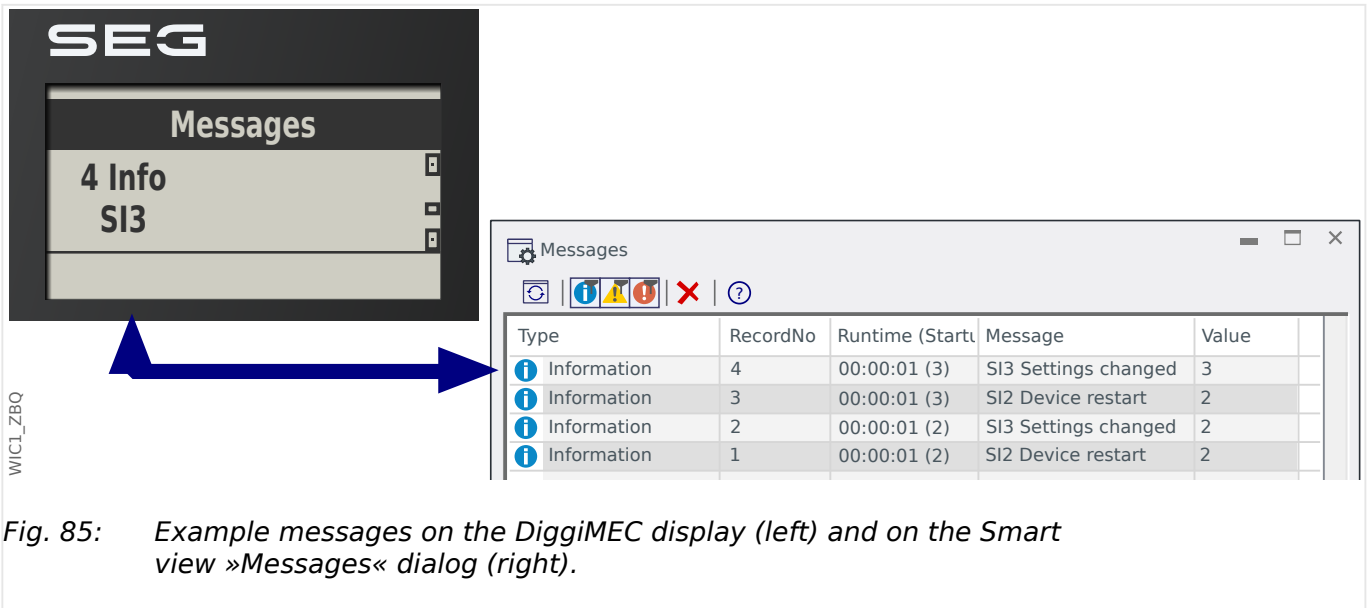

Fig. 85: Example messages on the DiggiMEC display (left) and on the Smart view »Messages« dialog (right).

All messages are displayed together with an identifier (e. g. “**S12** Device restart” or “**S13** Settings changed”); this identifier makes it easier to locate detailed information about it. The identifier always starts with an “**S**”, next comes either an “**I**” (for “Information”), a “**W**” (for “Warning”), or an “**E**” (for “Error”).

General idea:

- **E** - Errors indicate serious problems. It is advisable to look up the message and take the recommended actions.
- **W** - Warnings should be checked by the user. They might indicate a problem that needs to be solved, so that - depending on the message and application - it might be advisable to check warnings.
- **I** - Information messages can be helpful for a thorough analysis of a problem, but in general, such messages have indeed only an informative character and do not affect the operation of the WIC1.

The example messages shown above (↪Fig. 85) are two pairs of device restarts (**S12**) plus setting changes (**S13**). Note that all timestamps (third column) are relative times since the last restart, because the WIC1 lacks a real-time clock. Whenever there is such a pair of **S12** and **S13**, occurring within only a second time, it is a warm restart following a settings change via DIP/HEX switches. (See also [↪Chapter 2.2.2.](#))

The Self-Supervision messages can be conveniently browsed through using *Smart view*.

All messages are listed in one dialog window. There are buttons  in the toolbar of this dialog that allow for restricting the list to particular severity types: It is possible to e. g. hide all “information” messages and show only the types “warning” and “error”.

There is also a delete button : It allows for removing the currently selected message plus all older ones.



Note that it is not possible to pick only one particular message for deletion. A deletion always removes all messages until (including) the currently selected one.

7.3 Backup Protection / Self-Supervision

Depending on the [type code](#) the WIC1 features a Self-Supervision Mode which either operates the Trip Coil Output "TC" (Backup Phase Overcurrent Protection) or the Flag Indicator Output "FI" (as an Alarm signal). It is activated automatically if the WIC1 detects a device-internal (hardware or software) error that still persists after several automatic restarts (see [↪7.3.1 Activation of the Backup Protection / Self-Supervision Mode](#)). In this case all other functionality is switched off and the "System Error" LED is lit up continuously. This is not a software function that can be activated or deactivated at any time, but it is a special hardware-based operating mode of the WIC1. (See also [↪"The »System« LED\(s\) - "Ready", "Error""](#))

Operating Mode (depends on WIC1 type code)	
Self-Supervision operates Trip Coil "TC" (Phase Overcurrent Backup Protection)	Self-Supervision operates Flag Indicator "FI" (Self-Supervision Alarm)
<p>For these device variants some minimum protection functionality is supplied in case of a permanent device-internal problem. If the Self-Supervision is triggered, only the Backup Protection is active, all other functionality is switched off. The WIC1 indicates this by the "System Error" LED being continuously lit up in red. There are two different device variants available:</p> <ul style="list-style-type: none"> • Trip immediately: As soon as the device has collected enough energy for a trip impulse. The device needs sufficient power supply for this. This will put the protected object out of operation even for normal operating currents. • Trip if $I \geq 20 \cdot I_{n,max}$: Because of the high fault current, the power supply is automatically sufficient for a fast trip. This will keep the protected object in operation until a very high short circuit current occurs.* 	<p>This device variants features indication of a permanent device-internal problem without tripping of a connected circuit breaker. If the Self-Supervision is triggered, only the Self-Supervision Alarm via Flag Indicator "FI" is active, all other functionality is switched off. The WIC1 indicates this by the "System Error" LED being continuously lit up in red. Beside indication, the Alarm then can be used to e.g. activate external backup protection or to put the protected object out of service in a controlled manner.**</p> <p>The device needs sufficient power supply to operate the Flag Indicator "FI".</p> <p>Please note that the Flag Indicator "FI" output cannot be used for other signals (e.g. a Trip) anymore in this case.</p> <p>»TCM« - TCM [74TC]: The TCM function still can be used in combination with this device variant. It is activated by setting [Device Para / WIC1 / Output] »Prot . TCM« = "Active". After activation the function works during normal operation of the WIC1 as described under ↪5.14.2 »TCM« - Trip Circuit Monitoring [74TC].</p>

WARNING!



* Device variant "Trip if $I \geq 20 \cdot I_{n,max}$ ": Below the current threshold there is no protection functionality from the WIC1 at all. Please make sure there is external backup protection or that this is acceptable considering personal safety and potential equipment damage in case of a fault situation.

** Device variant "Self-Supervision Alarm": The Alarm via "FI" does only indicate a problem, but there is no protection functionality of the WIC1 at all in this operating mode. Please make sure there is external backup protection or that this is acceptable considering personal safety and potential equipment damage in case of a fault situation.

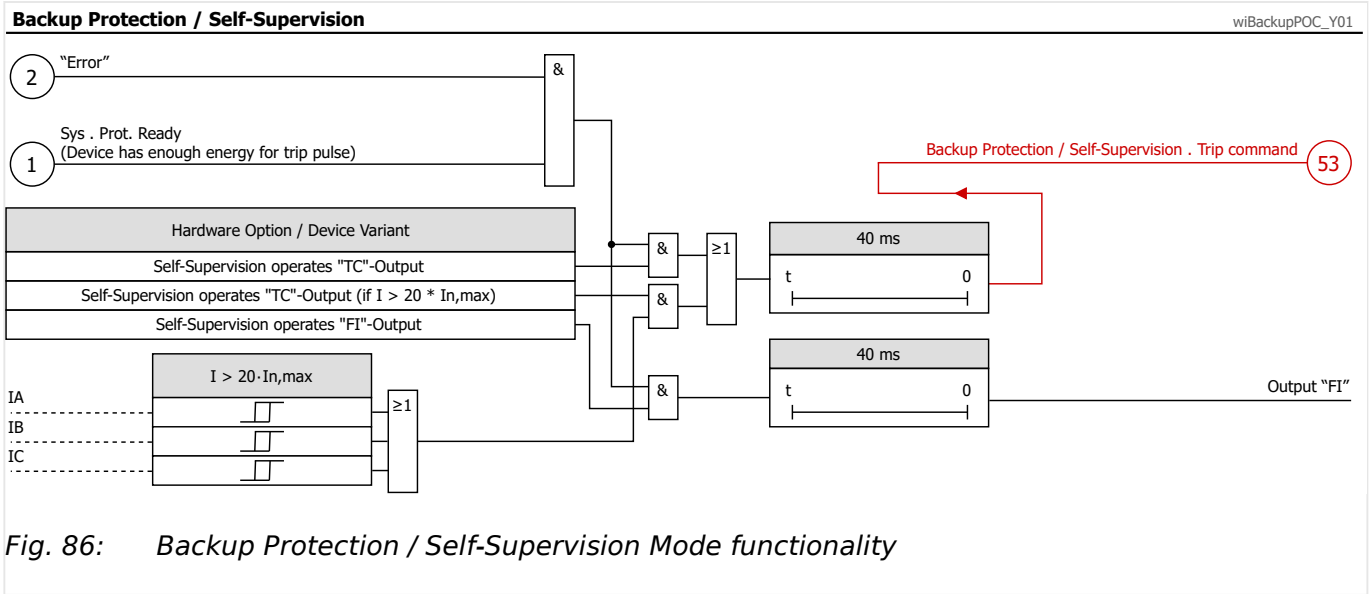

7.3.1 Activation of the Backup Protection / Self-Supervision Mode

- If the WIC1 detects a device-internal (hardware or software) error it initiates a device restart. This is logged by the Self-Supervision.
- If within 10 minutes another internal error is detected the WIC1 initiates a device restart into a restricted "Protection-Only" mode. (See also ↪"The »System« LED(s) - "Ready", "Error"".)

In this operating mode only protection and supervision functions are running. No communication, no SCADA, etc.

This mode is logged as a warning in the Self-Supervision messages. (The functionality to read the stored log entries has also been switched off. However, the entries can be read after the WIC1 has been restarted into normal operating mode.)

- If within another 10 minutes a third internal error is detected the WIC1 initiates a device restart into a Backup Protection / Self-Supervision Mode. (The software gets intentionally halted within the bootloader stage.)

This is indicated at the WIC1 by the middle / "System Error" LED shining constantly **red**. (See also ↪"The »System« LED(s) - "Ready", "Error"".)

Since the software remains in the bootloader stage it is possible that the user starts a firmware upgrade. Chances are that such an upgrade solves the error.



The Direct Command »Sys . Force Backup Prot.« allows for (manually) entering the Backup Protection / Self-Supervision Mode. This way one can test the function, e. g. during commissioning.

This manually started mode gets stopped after approx. 10 seconds by an automatic restart. But of course, a manual cold restart also takes the WIC1 back to normal operation.

8 Commissioning

Before starting work on an opened switchboard it is imperative that the complete switchboard is dead and the following 5 safety regulations are always met:

DANGER!



Safety precautions:

- Disconnect from the power supply (if available for the WIC1)
- Secure against reconnection
- Verify if the equipment is dead
- Connect to ground and short-circuit all phases
- Cover or safeguard all live adjacent parts

DANGER!



The secondary circuit of a current transformer must never be opened during operation. The prevailing high voltages are dangerous to life.

WARNING!



Even when the auxiliary voltage, or the protective device, is switched off, it is likely that there are still hazardous voltages at the component connections.

All locally applicable national and international installation and safety regulations for working at electrical power installations must always to be followed (e.g. VDE, EN, DIN, IEC).



It is strongly recommended to fasten a permanent label somewhere in the low-voltage cell (e. g. as a banneret fixed to the CT cables) with information about the CT type. After the site has been put into operation the medium-voltage parts must no longer be accessed, so that there is no way anymore to find out the CT type.

WARNING!



Prior to the initial voltage connection, the following must be guaranteed:

- Correct grounding of the device
- All signal circuits must be tested
- All control circuits must be tested
- The transformer wiring must be checked
- Correct rating of the CTs
- Correct burden of the CTs
- The operational conditions must be in line with the Technical Data
- Correct rating and function of the CT fuses;
- Correct wiring of all digital inputs
- Polarity and capacity of the supply voltage (if applicable for this WIC1 variant)

8.1 Commissioning / Protection Test

WARNING!



Putting into operation/Protection test must be carried out by authorized and qualified personnel. Before the device is put into operation the related documentation has to be read and understood.

WARNING!



With any test of the protection functions the following has to be checked:

- Are all signals/messages correctly generated?
- Do all general parameterized blocking functions work properly?
- Do all temporary parameterized (via DI) blocking functions work properly?
- To enable checks on all LEDs and relay functions, these have to be provided with the relevant alarm/pickup/tripping signals of the respective protection functions/elements.

WARNING!



Check of all temporary blockings:

In order to avoid malfunctions, all blockings related to tripping/non-tripping of protection functions have to be tested.

NOTICE!



Prior to the initial operation of the protection device all tripping times and values shown in the adjustment list have to be confirmed by a secondary test

CAUTION!



In most countries, there are specific national regulations and standards about functional and protection tests that must be carried out on a regular basis.

These must be followed carefully in any case.

Accessories for Commissioning Work

For commissioning of the protection system, the following accessories should be available:

- For WIC1-1 and WIC1-4: a **PC4** adapter or **DiggiMEC**; recommended: a PC with an installed *Smart view* software
- Secondary testing system
- Screwdriver; cross slot type, size 1; 3 mm slot
- Setting parameters

8.1.1 Special Features of the WIC1 Test

For every self-supplied device, it has to be taken into account that the CT has to feed more power than this is the case for protection devices with an additional aux. voltage source. Furthermore, it has to be noted that - with reference to the entire measuring range of the protection devices - the input impedance of the individual phases is not linear.

The WIC1 receives its supply energy out of the measuring circuit. Due to the circuit logic the WIC1 changes its measuring load periodically (with a period of ~1 kHz).

This can have an effect on the feeding source.

8.1.2 Selection of the Secondary Test System

When selecting the secondary test system, the following particulars should be taken into account.

- Secondary test system to be used as current source.
- Three phases for the earth current test, one phase for the phase current test (see [↪8.1.5 Functional Test](#)).
- Sufficient output power for the thresholds to be tested (see [↪8.1.5.2 Pickup Thresholds for the Phase Overcurrent Stage I>](#), [↪8.1.5.3 Pickup Thresholds for the Short-Circuit \(Phase Overcurrent\) Stage I>>](#)).
- The highest possible test current for testing via the test winding is at 22.4 A. A test system with an output current up to 10 A should be sufficient.
- A timer for measuring the time 0 ... 300 s. The time signal can be measured via the WIC1 outputs TC+/TC- or FI+/FI- (WIC1-4: Out+/Out-) as positive edge of a 24 V signal.

8.1.3 Measurement of the Resistive Burden

The commissioning often involves measuring the resistive burden at the current inputs, so that the impedance on the secondary side is known.

- One method is to disconnect all wirings between the CTs and the WIC1, so that all the resistances can be measured.
- Another method is to disconnect only the WIC1 current measuring inputs and measure the total resistance (i. e. forward wire + CT winding resistance + back wire).

In this case it is helpful to know the CT winding resistance in advance. For the construction type 2, [the values](#) are listed in the [Technical Data](#).

8.1.4 Checks During Commissioning

When putting into operation, the wiring and setting of the protection relay should be checked. Here the person doing the commissioning work is assisted by the integrated test windings of the WIC1 protection system, which are on the front of the relay. Hence any wiring jobs as well as actions in the cable connection area can be disregarded.

WARNING!



The [test sockets](#) are not usable at all if [Converter CTs \(1 A or 5 A\)](#) are connected to the WIC1. For such an application, the usual 1 A / 5 A secondary tests have to be carried out.

We have to stress once again that all usual safety measures must also be taken with the Converter CTs. In particular, always short-circuit the secondary side (i. e. the WIC1 side in this case) of the Converter CTs before loosening the terminals (to the WIC1). Ignoring this can result in dangerous voltages at the open contacts.

8.1.4.1 Test Windings, Test Sockets

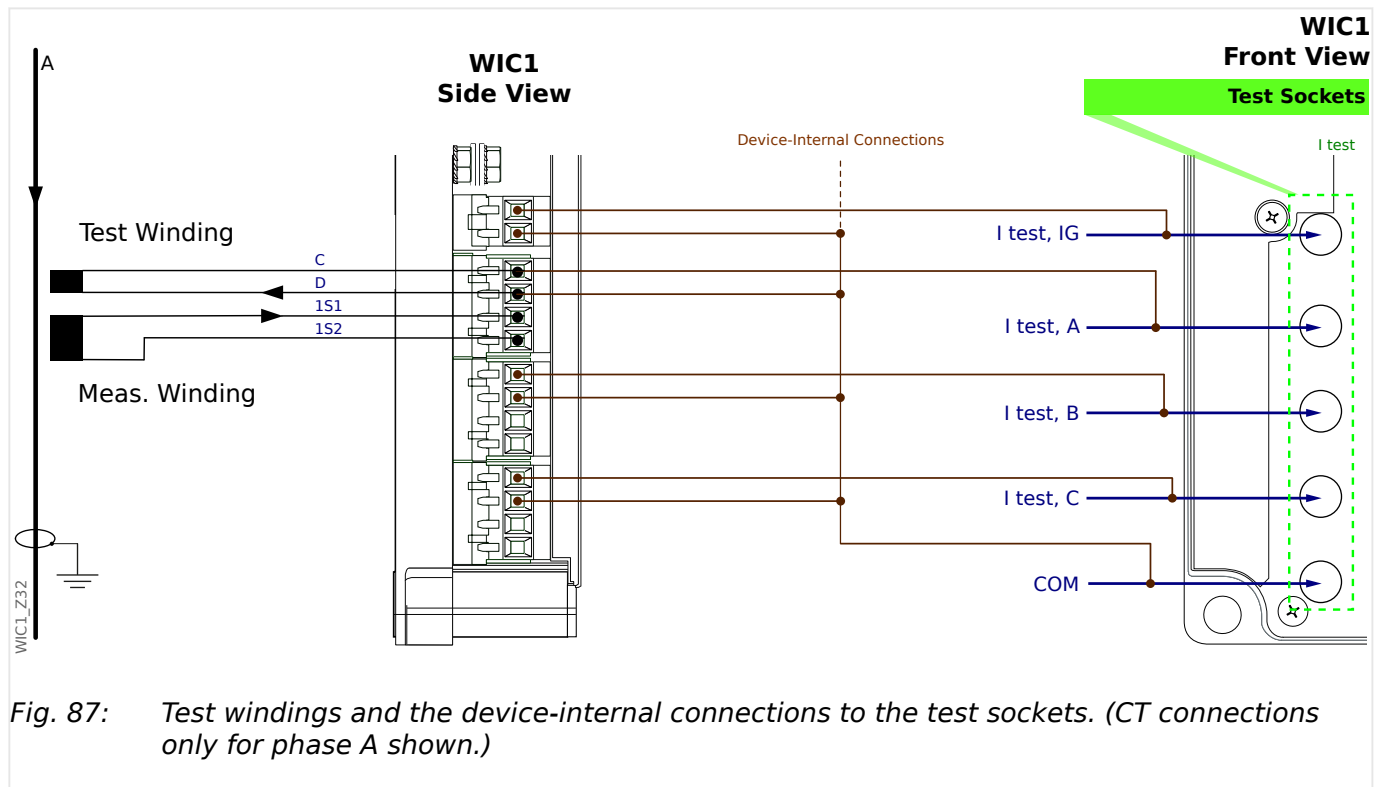

Fig. 87: Test windings and the device-internal connections to the test sockets. (CT connections only for phase A shown.)

This chapter refers only to applications with the WIC1 CTs (WE2, W2,..., W6, because the test sockets cannot be used with the Converter CTs (1 A or 5 A).)

The WIC1 and its CTs (see ↪2.6.1.3 Order Form of the WIC1-Compatible Current Transformers, ↪3.3 Current Transformers (CTs)) feature special test sockets because the device cannot be tested secondary as usual. The test sockets offer the possibility to test WIC1 with conventional 1 A/5 A test devices. The fed test current flows into a tertiary test winding of the CT (C/D terminals) and induces a current to the secondary side. Every WIC1 CT is designed such that the ratio between test current and secondary current is the same.

A test socket current of 0.32 A induces a secondary current of 1.0 In,min. ↪10.5.5 Test Windings, Test Sockets contains a table giving an overview of the current relationships between primary, secondary and test winding side for the different CT types.

Using the test sockets may place high demands on the test equipment regarding output power and voltage. Please refer to ↪10.5.5 Test Windings, Test Sockets for more information.

Please note that the tolerances only apply to primary input currents. Current infeed via the test inputs may result in lower accuracy.

Please make sure no primary current is flowing during a test via the test inputs as this may have a negative impact on the secondary current and affect the result . Once the tests have been completed, the test inputs must be operated open again to avoid any influence on the primary current measurement.

If you have spent care on all this but the measurements are still wrong, then check the wiring of the contacts and the phase sequence. See also the Troubleshooting entry about wrong measuring and tripping values.

8.1.4.2 Wiring Checks

Wiring has to be checked with the circuitry shown in the diagram below.

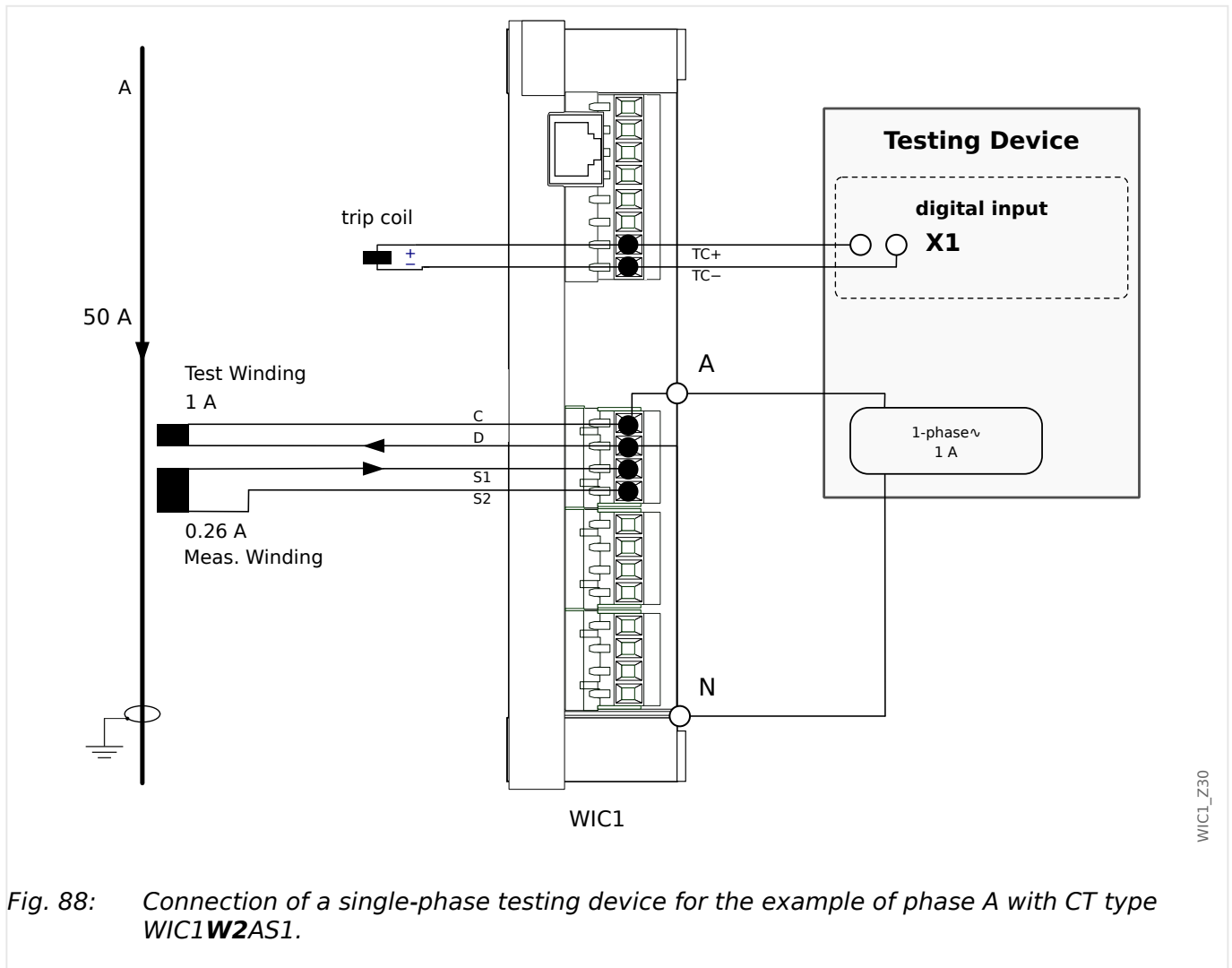

Fig. 88: Connection of a single-phase testing device for the example of phase A with CT type WIC1W2AS1.

The testing current is fed via sockets A, B, C and N. The test winding is rated such that the fed current of 1 A balances a primary current of 50 A (for an example CT type W2 : 16 A ... 56 AAS1).

CAUTION!



It is not allowed to connect any active voltage to the trip coil output or to the output (flag indicator / relay output).

CAUTION!



For a WIC1-4, it is also necessary that the configured operating mode matches the connected hardware!

(For example, it is not permissible to connect a flag indicator and set the operating mode to “Syst. O.K. & Ext.Suppl.”. See also the related Self-Supervision warnings [SW 3](#), [SW 4](#).)

Moreover, the electrical energy that an output relay drains with operating mode “Syst. O.K. & Ext.Suppl.” requires that the WIC1-4 is supplied by an external auxiliary voltage.

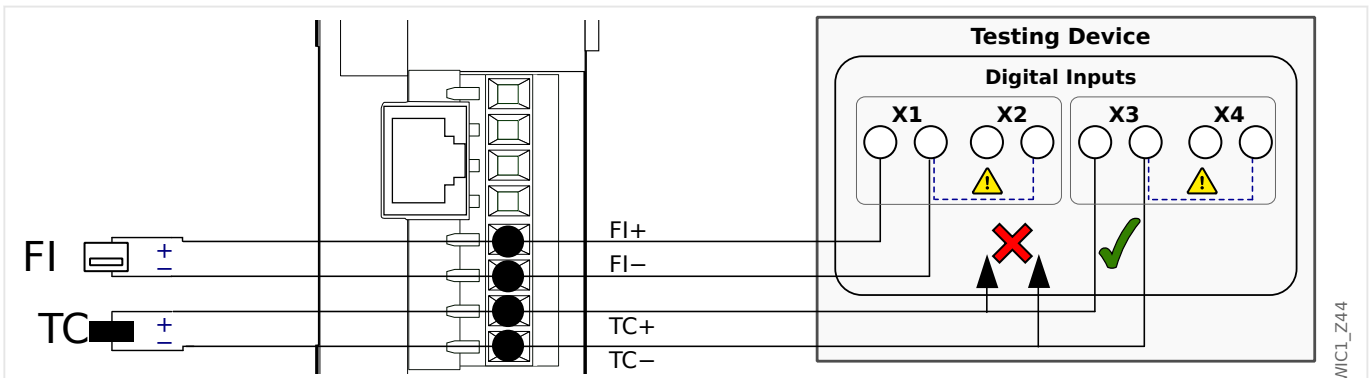

Fig. 89: **Note:** The two outputs may be connected at the same time to test equipment (e. g. to binary inputs of an Omicron[®] device) only if these two binary inputs do **not** share a common potential. Otherwise this external potential bridge, together with device-internal circuits, can produce incorrect test results.

8.1.4.3 Self-Supervision Contact for the WIC1-4

An externally supplied WIC1-4 allows for connecting an output relay that operates as a “Healthy” / self-supervision contact. (See [→3.10.1 Self-Supervision Contact for the WIC1-4](#).)

8.1.4.4 WIC1 Settings

The protection parameters must be carefully set, see the respective chapters in this document. For later reference, the setting values can be written directly on the sticker that is affixed on the relay.

8.1.5 Functional Test

There are two methods to carry out the tests: Primary test and secondary test.

When the primary test method is used, the test current is impressed via the primary winding.

When the secondary test method is used, the test current is impressed via the C-D test winding, see also [→8.1.4.1 Test Windings, Test Sockets](#).

8.1.5.1 Test Currents

The transformation ratio of primary currents to secondary currents of the CTs are equally proportionate as the test current via the C-D winding to the secondary current. This means, no matter which CT type is in operation, for the secondary test always the same test values are used.

<i>I_n</i>	Test values via C-D winding with the different CT types															
DIP 1-1	0	1	0	1	0	1	0	1	0	1	0	1	0	1	0	1
DIP 1-2	0	0	1	1	0	0	1	1	0	0	1	1	0	0	1	1
DIP 1-3	0	0	0	0	1	1	1	1	0	0	0	0	1	1	1	1
DIP 1-4	0	0	0	0	0	0	0	0	1	1	1	1	1	1	1	1
HEX switch 1	0	1	2	3	4	5	6	7	8	9	A	B	C	D	E	F
» <i>I_n</i> ,relative«	1.0	1.125	1.25	1.375	1.5	1.625	1.75	1.875	2.0	2.125	2.25	2.5	2.75	3.0	3.25	3.5
WIC1-W2 [A]	16	18	20	22	24	26	28	30	32	34	36	40	44	48	52	56
Test current C-D [A]	0.32	0.36	0.40	0.44	0.48	0.52	0.56	0.60	0.64	0.68	0.72	0.80	0.88	0.96	1.04	1.12
WIC1-W3 [A]	32	36	40	44	48	52	56	60	64	68	72	80	88	96	104	112
Test current C-D [A]	0.32	0.36	0.40	0.44	0.48	0.52	0.56	0.60	0.64	0.68	0.72	0.80	0.88	0.96	1.04	1.12
WIC1-W4 [A]	64	72	80	88	96	104	112	120	128	136	144	160	176	192	208	224
Test current C-D [A]	0.32	0.36	0.40	0.44	0.48	0.52	0.56	0.60	0.64	0.68	0.72	0.80	0.88	0.96	1.04	1.12
WIC1-W5 [A]	128	144	160	176	192	208	224	240	256	272	288	320	352	384	416	448
Test current C-D [A]	0.32	0.36	0.40	0.44	0.48	0.52	0.56	0.60	0.64	0.68	0.72	0.80	0.88	0.96	1.04	1.12
WIC1-W6 [A]	256	288	320	352	384	416	448	480	512	544	576	640	704	768	832	896
Test current C-D [A]	0.32	0.36	0.40	0.44	0.48	0.52	0.56	0.60	0.64	0.68	0.72	0.80	0.88	0.96	1.04	1.12

This means when *I_n* is multiplied with the setting value of the relevant protection element of *I_>*, *I_{>>}*, *I_{>>>}* or *I_{G>}*, *I_{G>>}* it equals the test current via the test winding. This is then independent of the CT type. The following tables show all setting values for the protection steps *I_>*, *I_{>>}* and *I_{G>}*.

8.1.5.2 Pickup Thresholds for the Phase Overcurrent Stage I>

The nominal current I_n is set via the switches DIP 1-1...1-4 or HEX 1 (independent of the CT type in units of the lower current limit $I_{n,min}$).

Via the switches DIP 2-1...2-4 or HEX 3, the pickup threshold $I>$ is set, but this is in units of I_n . (See also [↔12.1 Appendix – Settings via DIP / HEX Switches.](#))

Therefore the pickup threshold $I>$ in Ampere depends on both DIP 1-1...1-4 / HEX 1 and on DIP 2-1...2-4 / HEX 3, and consequently there is an analogous dependency for the test current (in Ampere) that needs to be fed into the C-D winding. The following table shows this test current (in Ampere):

I>	Setting of the I> threshold															
DIP 2-1	0	1	0	1	0	1	0	1	0	1	0	1	0	1	0	1
DIP 2-2	0	0	1	1	0	0	1	1	0	0	1	1	0	0	1	1
DIP 2-3	0	0	0	0	1	1	1	1	0	0	0	0	1	1	1	1
DIP 2-4	0	0	0	0	0	0	0	0	1	1	1	1	1	1	1	1
HEX switch 3	0	1	2	3	4	5	6	7	8	9	A	B	C	D	E	F*
Resulting setting I> [In] →	0.90	0.95	1.00	1.05	1.10	1.15	1.20	1.30	1.40	1.50	1.60	1.80	2.00	2.25	2.50	—*
Setting for the nominal current I_n [In,min] ↓	Test current via C-D winding [A] ↓															
Hex 1 = „0“ ($I_n = 1.0$)	0.288	0.304	0.320	0.336	0.352	0.368	0.384	0.416	0.448	0.480	0.512	0.576	0.640	0.720	0.800	—*
Hex 1 = „1“ ($I_n = 1.125$)	0.324	0.342	0.360	0.378	0.396	0.414	0.432	0.468	0.504	0.540	0.576	0.648	0.720	0.810	0.900	—*
Hex 1 = „2“ ($I_n = 1.25$)	0.360	0.380	0.400	0.420	0.440	0.460	0.480	0.520	0.560	0.600	0.640	0.720	0.800	0.900	1.000	—*
Hex 1 = „3“ ($I_n = 1.375$)	0.396	0.418	0.440	0.462	0.484	0.506	0.528	0.572	0.616	0.660	0.704	0.792	0.880	0.990	1.100	—*
Hex 1 = „4“ ($I_n = 1.5$)	0.432	0.456	0.480	0.504	0.528	0.552	0.576	0.624	0.672	0.720	0.768	0.864	0.960	1.080	1.200	—*
Hex 1 = „5“ ($I_n = 1.625$)	0.468	0.494	0.520	0.546	0.572	0.598	0.624	0.676	0.728	0.780	0.832	0.936	1.040	1.170	1.300	—*
Hex 1 = „6“ ($I_n = 1.75$)	0.504	0.532	0.560	0.588	0.616	0.644	0.672	0.728	0.784	0.840	0.896	1.008	1.120	1.260	1.400	—*
Hex 1 = „7“ ($I_n = 1.875$)	0.540	0.570	0.600	0.630	0.660	0.690	0.720	0.780	0.840	0.900	0.960	1.080	1.200	1.350	1.500	—*
Hex 1 = „8“ ($I_n = 2.0$)	0.576	0.608	0.640	0.672	0.704	0.736	0.768	0.832	0.896	0.960	1.024	1.152	1.280	1.440	1.600	—*
Hex 1 = „9“ ($I_n = 2.125$)	0.612	0.646	0.680	0.714	0.748	0.782	0.816	0.884	0.952	1.020	1.088	1.224	1.360	1.530	1.700	—*
Hex 1 = „A“ ($I_n = 2.25$)	0.648	0.684	0.720	0.756	0.792	0.828	0.864	0.936	1.008	1.080	1.152	1.296	1.440	1.620	1.800	—*
Hex 1 = „B“ ($I_n = 2.5$)	0.720	0.760	0.800	0.840	0.880	0.920	0.960	1.040	1.120	1.200	1.280	1.440	1.600	1.800	2.000	—*
Hex 1 = „C“ ($I_n = 2.75$)	0.792	0.836	0.880	0.924	0.968	1.012	1.056	1.144	1.232	1.320	1.408	1.584	1.760	1.980	2.200	—*
Hex 1 = „D“ ($I_n = 3.0$)	0.864	0.912	0.960	1.008	1.056	1.104	1.152	1.248	1.344	1.440	1.536	1.728	1.920	2.160	2.400	—*
Hex 1 = „E“ ($I_n = 3.25$)	0.936	0.988	1.040	1.092	1.144	1.196	1.248	1.352	1.456	1.560	1.664	1.872	2.080	2.340	2.600	—*
Hex 1 = „F“ ($I_n = 3.5$)	1.008	1.064	1.120	1.176	1.232	1.288	1.344	1.456	1.568	1.680	1.792	2.016	2.240	2.520	2.800	—*

— * This DIP / HEX setting deactivates the protection stage.

8.1.5.3 Pickup Thresholds for the Short-Circuit (Phase Overcurrent) Stage I>>

The nominal current I_n is set via the switches DIP 1-1...1-4 or HEX 1 (independent of the CT type in units of the lower current limit $I_{n,min}$).

Via the switches DIP 3-1...3-4 or HEX 5, the pickup threshold $I_{>>}$ is set, but this is in units of I_n . (See also [12.1 Appendix – Settings via DIP / HEX Switches.](#))

Therefore the pickup threshold $I_{>>}$ in Ampere depends on both DIP 1-1...1-4 / HEX 1 and on DIP 3-1...3-4 / HEX 5, and consequently there is an analogous dependency for the test current (in Ampere) that needs to be fed into the C-D winding. The following table shows this test current (in Ampere):

I>>	Setting of the I>> threshold															
DIP 2-1	0	1	0	1	0	1	0	1	0	1	0	1	0	1	0	1
DIP 2-2	0	0	1	1	0	0	1	1	0	0	1	1	0	0	1	1
DIP 2-3	0	0	0	0	1	1	1	1	0	0	0	0	1	1	1	1
DIP 2-4	0	0	0	0	0	0	0	0	1	1	1	1	1	1	1	1
HEX switch 3	0	1	2	3	4	5	6	7	8	9	A	B	C	D	E	F*
Resulting setting I>> [In] →	1	2	3	4	5	6	7	8	9	10	12	14	16	18	20	—*
Setting for the nominal current I_n [In,min] ↓	Test current via C-D winding [A] ↓															
Hex 1 = „0“ ($I_n = 1.0$)	0.32	0.64	0.96	1.28	1.60	1.92	2.24	2.56	2.88	3.20	3.84	4.48	5.12	5.76	6.40	—*
Hex 1 = „1“ ($I_n = 1.125$)	0.36	0.72	1.08	1.44	1.80	2.16	2.52	2.88	3.24	3.60	4.32	5.04	5.76	6.48	7.20	—*
Hex 1 = „2“ ($I_n = 1.25$)	0.40	0.80	1.20	1.60	2.00	2.40	2.80	3.20	3.60	4.00	4.80	5.60	6.40	7.20	8.00	—*
Hex 1 = „3“ ($I_n = 1.375$)	0.44	0.88	1.32	1.76	2.20	2.64	3.08	3.52	3.96	4.40	5.28	6.16	7.04	7.92	8.80	—*
Hex 1 = „4“ ($I_n = 1.5$)	0.48	0.96	1.44	1.92	2.40	2.88	3.36	3.84	4.32	4.80	5.76	6.72	7.68	8.64	9.60	—*
Hex 1 = „5“ ($I_n = 1.625$)	0.52	1.04	1.56	2.08	2.60	3.12	3.64	4.16	4.68	5.20	6.24	7.28	8.32	9.36	10.40	—*
Hex 1 = „6“ ($I_n = 1.75$)	0.56	1.12	1.68	2.24	2.80	3.36	3.92	4.48	5.04	5.60	6.72	7.84	8.96	10.08	11.20	—*
Hex 1 = „7“ ($I_n = 1.875$)	0.60	1.20	1.80	2.40	3.00	3.60	4.20	4.80	5.40	6.00	7.20	8.40	9.60	10.80	12.00	—*
Hex 1 = „8“ ($I_n = 2.0$)	0.64	1.28	1.92	2.56	3.20	3.84	4.48	5.12	5.76	6.40	7.68	8.96	10.24	11.52	12.80	—*
Hex 1 = „9“ ($I_n = 2.125$)	0.68	1.36	2.04	2.72	3.40	4.08	4.76	5.44	6.12	6.80	8.16	9.52	10.88	12.24	13.60	—*
Hex 1 = „A“ ($I_n = 2.25$)	0.72	1.44	2.16	2.88	3.60	4.32	5.04	5.76	6.48	7.20	8.64	10.08	11.52	12.96	14.40	—*
Hex 1 = „B“ ($I_n = 2.5$)	0.80	1.60	2.40	3.20	4.00	4.80	5.60	6.40	7.20	8.00	9.60	11.20	12.80	14.40	16.00	—*
Hex 1 = „C“ ($I_n = 2.75$)	0.88	1.76	2.64	3.52	4.40	5.28	6.16	7.04	7.92	8.80	10.56	12.32	14.08	15.84	17.60	—*
Hex 1 = „D“ ($I_n = 3.0$)	0.96	1.92	2.88	3.84	4.80	5.76	6.72	7.68	8.64	9.60	11.52	13.44	15.36	17.28	19.20	—*
Hex 1 = „E“ ($I_n = 3.25$)	1.04	2.08	3.12	4.16	5.20	6.24	7.28	8.32	9.36	10.40	12.48	14.56	16.64	18.72	20.80	—*
Hex 1 = „F“ ($I_n = 3.5$)	1.12	2.24	3.36	4.48	5.60	6.72	7.84	8.96	10.08	11.20	13.44	15.68	17.92	20.16	22.40	—*

— * This DIP / HEX setting deactivates the protection stage.

8.1.6 Special Features for Tests of Calculated Ground (Earth) Overcurrent

Functional Description

Depending on the WIC1 settings, the ground (earth) current can be calculated instead of being measured. Then it is established from the geometrical amount of the three phase current values, more or less a numerical Holmgreen. If, for instant, a single-phase test current is impressed, the measuring value (tripping value) in the ground (earth) current path equals the current in the tested phase. If, with a phase shift of 120° a three-phase test current is impressed, the measuring value in the ground (earth) current path equals zero.

Requirement for the Test System

The WIC1 is powered by the phase CTs. In order to guarantee a reliable tripping a minimal current has to flow, see [↔10.1.6 Power Supply](#). If the setting of the ground overcurrent threshold I_G is lower than the smallest possible 1-phase supply via the phase CTs, then the ground current tripping can only be tested by a three-phase current source. Only if the set ground overcurrent threshold is higher than the smallest possible 1-phase supply via the phase CTs, then the test can be performed with a single-phase current source.

8.1.6.1 Tripping Thresholds for the Calculated Ground Overcurrent Stage IG>

NOTICE!



The device variants WIC1-xx**G** feature a ground (earth) current measuring input, and both measuring input and test winding is for 1 A rated ground (earth) current. (This means the test winding simply has a 1:1-ratio.) The values for the test current via C-D winding in the following table are therefore **not** valid for these device variants. (Or, strictly speaking, they can be used if the WIC1 has been set to calculated ground (earth) current via Smart view (PC) / DiggiMEC, but then the DIP/HEX switch settings listed below are invalid)!

In other words: The following description and values about commissioning the ground (earth) overcurrent protection refers to device variants WIC1-xx**N** without ground (earth) current measuring input.

The nominal current I_n is set via the switches DIP 1-1...1-4 or HEX 1 (independent of the CT type in units of the lower current limit $I_{n,min}$).

Via the switches DIP 4-1...4-4 or HEX 7, the pickup threshold $I_{G>}$ is set, but this is in units of I_n . (See also [↪12.1 Appendix - Settings via DIP / HEX Switches.](#))

Therefore the pickup threshold $I_{G>}$ in Ampere depends on both DIP 1-1...1-4 / HEX 1 and on DIP 4-1...4-4 / HEX 7, and consequently there is an analogous dependency for the test current (in Ampere) that needs to be fed into the C-D winding. The following table shows this test current (in Ampere):

IG>	Setting of the IG> threshold															
	0	1	0	1	0	1	0	1	0	1	0	1	0	1	0	1
DIP 4-1	0	1	0	1	0	1	0	1	0	1	0	1	0	1	0	1
DIP 4-2	0	0	1	1	0	0	1	1	0	0	1	1	0	0	1	1
DIP 4-3	0	0	0	0	1	1	1	1	0	0	0	0	1	1	1	1
DIP 4-4	0	0	0	0	0	0	0	0	1	1	1	1	1	1	1	1
HEX switch 7	0	1	2	3	4	5	6	7	8	9	A	B	C	D	E	F*
Resulting setting IG>	0.2	0.3	0.4	0.5	0.6	0.7	0.8	0.9	1	1.2	1.4	1.6	1.8	2.0	2.5	— *
[In] →																
Setting for the nominal current I_n [In,min] ↓	Test current via C-D winding [A] ↓															
Hex 1 = „0“ ($I_n = 1.0$)	0.064	0.096	0.128	0.160	0.192	0.224	0.256	0.288	0.320	0.384	0.448	0.512	0.576	0.640	0.800	— *
Hex 1 = „1“ ($I_n = 1.125$)	0.072	0.108	0.144	0.180	0.216	0.252	0.288	0.324	0.360	0.432	0.504	0.576	0.648	0.720	0.900	— *
Hex 1 = „2“ ($I_n = 1.25$)	0.080	0.120	0.160	0.200	0.240	0.280	0.320	0.360	0.400	0.480	0.560	0.640	0.720	0.800	1.000	— *
Hex 1 = „3“ ($I_n = 1.375$)	0.088	0.132	0.176	0.220	0.264	0.308	0.352	0.396	0.440	0.528	0.616	0.704	0.792	0.880	1.100	— *
Hex 1 = „4“ ($I_n = 1.5$)	0.096	0.144	0.192	0.240	0.288	0.336	0.384	0.432	0.480	0.576	0.672	0.768	0.864	0.960	1.200	— *
Hex 1 = „5“ ($I_n = 1.625$)	0.104	0.156	0.208	0.260	0.312	0.364	0.416	0.468	0.520	0.624	0.728	0.832	0.936	1.040	1.300	— *
Hex 1 = „6“ ($I_n = 1.75$)	0.112	0.168	0.224	0.280	0.336	0.392	0.448	0.504	0.560	0.672	0.784	0.896	1.008	1.120	1.400	— *
Hex 1 = „7“ ($I_n = 1.875$)	0.120	0.180	0.240	0.300	0.360	0.420	0.480	0.540	0.600	0.720	0.840	0.960	1.080	1.200	1.500	— *
Hex 1 = „8“ ($I_n = 2.0$)	0.128	0.192	0.256	0.320	0.384	0.448	0.512	0.576	0.640	0.768	0.896	1.024	1.152	1.280	1.600	— *
Hex 1 = „9“ ($I_n = 2.125$)	0.136	0.204	0.272	0.340	0.408	0.476	0.544	0.612	0.680	0.816	0.952	1.088	1.224	1.360	1.700	— *
Hex 1 = „A“ ($I_n = 2.25$)	0.144	0.216	0.288	0.360	0.432	0.504	0.576	0.648	0.720	0.864	1.008	1.152	1.296	1.440	1.800	— *
Hex 1 = „B“ ($I_n = 2.5$)	0.160	0.240	0.320	0.400	0.480	0.560	0.640	0.720	0.800	0.960	1.120	1.280	1.440	1.600	2.000	— *
Hex 1 = „C“ ($I_n = 2.75$)	0.176	0.264	0.352	0.440	0.528	0.616	0.704	0.792	0.880	1.056	1.232	1.408	1.584	1.760	2.200	— *

8.1.6.1 Tripping Thresholds for the Calculated Ground Overcurrent Stage IG>

IG>	Setting of the IG> threshold															
DIP 4-1	0	1	0	1	0	1	0	1	0	1	0	1	0	1	0	1
DIP 4-2	0	0	1	1	0	0	1	1	0	0	1	1	0	0	1	1
DIP 4-3	0	0	0	0	1	1	1	1	0	0	0	0	1	1	1	1
DIP 4-4	0	0	0	0	0	0	0	0	1	1	1	1	1	1	1	1
HEX switch 7	0	1	2	3	4	5	6	7	8	9	A	B	C	D	E	F*
Resulting setting IG> [In] →	0.2	0.3	0.4	0.5	0.6	0.7	0.8	0.9	1	1.2	1.4	1.6	1.8	2.0	2.5	—*
Hex 1 = „D“ (In = 3.0)	0.192	0.288	0.384	0.480	0.576	0.672	0.768	0.864	0.960	1.152	1.344	1.536	1.728	1.920	2.400	—*
Hex 1 = „E“ (In = 3.25)	0.208	0.312	0.416	0.520	0.624	0.728	0.832	0.936	1.040	1.248	1.456	1.664	1.872	2.080	2.600	—*
Hex 1 = „F“ (In = 3.5)	0.224	0.336	0.448	0.560	0.672	0.784	0.896	1.008	1.120	1.344	1.568	1.792	2.016	2.240	2.800	—*

— * This DIP / HEX setting deactivates the protection stage.

8.1.7 Sgen - Fault Simulator

For commissioning support and in order to analyze failures, the protective device offers the option to simulate measuring quantities.

After setting [[Device planning / Projected Elements]] »Sgen . Mode« = "use", the simulation menu can be found within the menu branch [Service / Sgen].

The simulation cycle consists of three sequences:

- Pre-fault;
- Failure;
- Post-fault sequence.

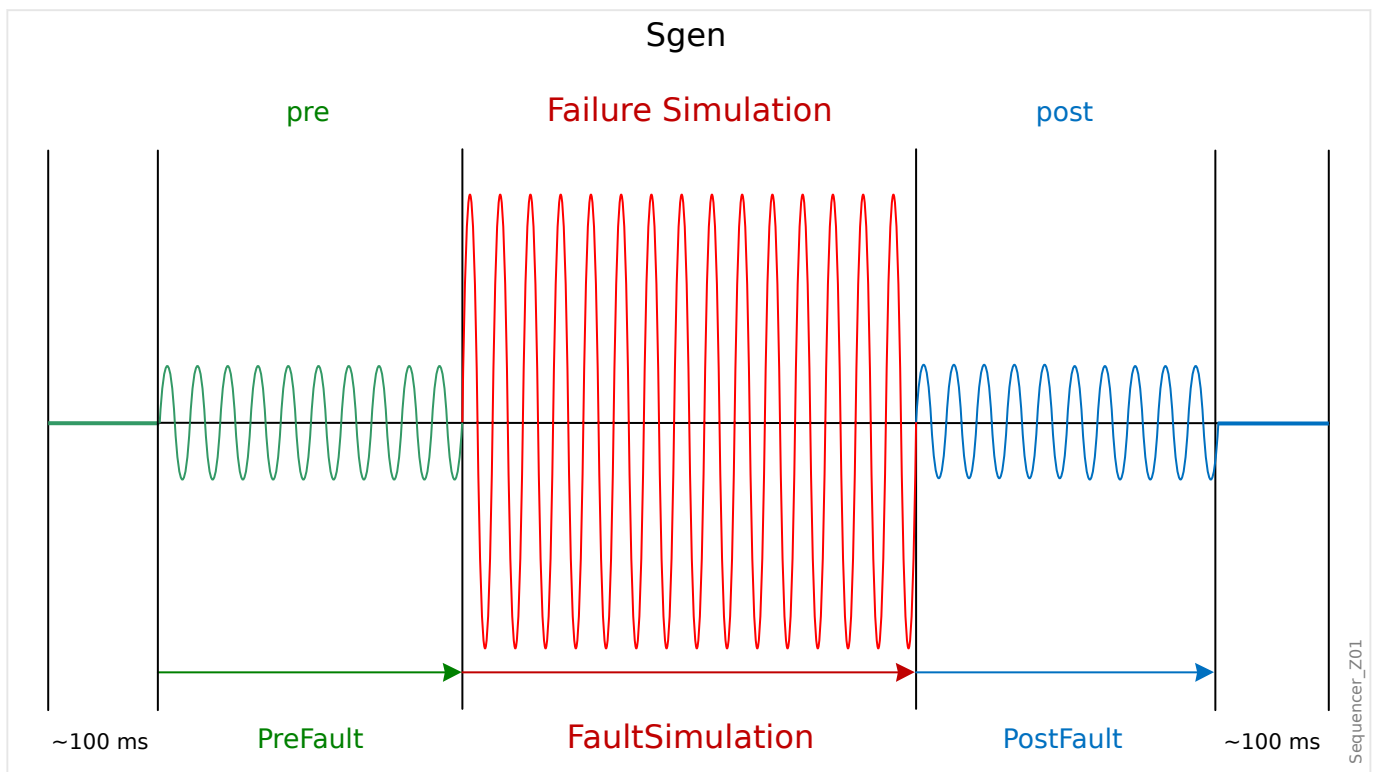

Within the menu branch [Service / Sgen / Configuration / Times], the duration of each sequence can be set as well as the phase and ground current amplitudes. The phase angles cannot be adjusted and are fixed to 0°/-120°/+120° (ground current 0°).

Within the menu branch [Service / Sgen / Process] there is one blocking parameter »ExBlo«. Assigned signals block the Fault Simulator. For example, it can be recommended for security considerations to have the Fault Simulator blocked if the circuit breaker is in closed position.

The simulation can be started and stopped via the Direct Controls [Service / Sgen / Process] . »Start Simulation« and »Stop Simulation«. Alternatively, the simulation can be started with an assigned signal to »Ex Start Simulation«.

Furthermore, there is the possibility to assign a signal to the parameter »Ex ForcePost«. An active assigned signal interrupts the running sequence immediately.

The simulation is also terminated immediately, if a phase current exceeds 0.35 In,min. After a simulation has been terminated from a real current, the next simulation cannot be started until two minutes have elapsed. Alternatively the device can be restarted to be ready for the next simulation.

NOTICE!



Please ensure that either no trip coil/circuit breaker is connected or that tripping is acceptable! During the simulation the protection functions work on the simulated currents and may trip depending on the simulated fault case. This would result in a trip command (»*TripCmd* «) triggering the trip coil and also a connected circuit breaker!

DANGER!



Setting the device into the simulation mode means taking the protective device out of operation for the duration of the simulation. Do not use this feature during operation of the device if the User cannot guarantee that there is a running and properly working backup protection.

8.2 Putting out of Operation - Plug out the Relay

WARNING!



Warning! Dismounting the relay will lead to a loss of the protection functionality. Ensure that there is a back-up protection. If you are not aware of the consequences of dismantling the device - stop! Don't start.

WARNING!



Inform SCADA before you start.

Switch off the power supply (if connected).

Ensure that the cabinet is dead and that there are no voltages that could lead to personal injury. Always short-circuit current transformers before loosening the terminals.

Use a screw-driver to plug out the cables.

Fasten the cables and terminals in the cabinet by means of cable clips to ensure that no accidental electrical connections are caused.

Hold the device at the front-side while opening the mounting nuts.

Remove the device carefully out of the cabinet.

In case no other device is to be mounted or replaced cover/close the cut-out in the front-door.

Close the cabinet.

8.3 Restart of the WIC1

Within the menu [Service / General] »Sys . User Restart«, the user can initiate a reboot of the WIC1.



The »System OK« LED is constantly green if - after the boot phase - the protection functions of the WIC1 are working and there is enough energy for issuing a trip signal.

More information can be found in [↪3.11 LEDs](#) and in [↪11 Troubleshooting](#).

8.4 Measuring the Trip Delay

Variants of type WIC1-#xxxxCxxxxx offer a freely configurable impulse output for a flag indicator. (See [↔3.10 Outputs \(Trip Coil, Flag Indicator, Relay Output\)](#) and the [Order Options](#).)

Although this FI output has its primary use in triggering a flag indicator it can also be used for special testing purposes if it is configurable; for example, it can be connected to the digital input of a testing device. If the TC (trip coil impulse output) is then connected to another digital input, then the testing device is able to measure the trip delay (i. e. the time-span between pickup and trip).

Hardware

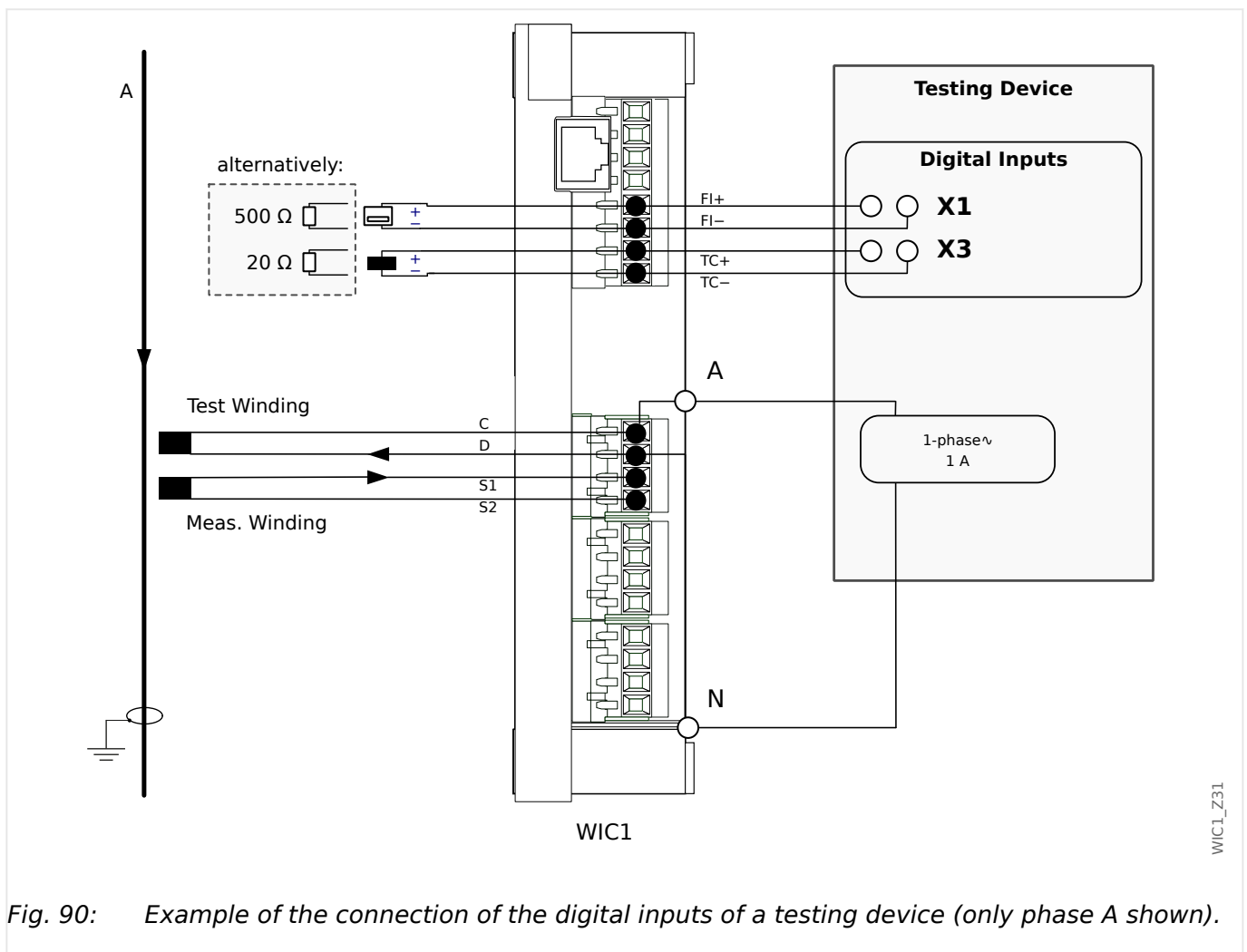

Fig. 90: Example of the connection of the digital inputs of a testing device (only phase A shown).

When connecting the impulse outputs for Trip Coil and Flag Indicator to the digital inputs of the testing device, there are important rules to be followed:

CAUTION!



In the Hardware settings of the testing device, set up the digital inputs so that they accept an input voltage between 17 VDC and 24 VDC as “binary 1”.

This means, in particular, that these digital inputs must not be defined as “potential-free”.

CAUTION!



It is not allowed to connect any active voltage to the trip coil output or to the output (flag indicator / relay output).

CAUTION!



For a WIC1-4, it is also necessary that the configured operating mode matches the connected hardware!

(For example, it is not permissible to connect a flag indicator and set the operating mode to "Syst. O.K. & Ext.Suppl.". See also the related Self-Supervision warnings [SW 3](#), [SW 4](#).)

Moreover, the electrical energy that an output relay drains with operating mode "Syst. O.K. & Ext.Suppl." requires that the WIC1-4 is supplied by an external auxiliary voltage.

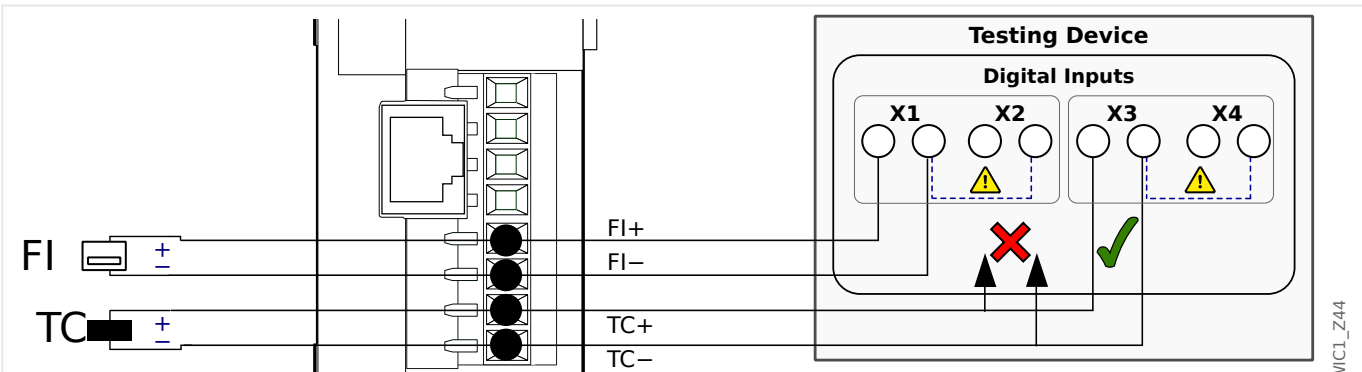

Fig. 91: **Note:** The two outputs may be connected at the same time to test equipment (e. g. to binary inputs of an Omicron® device) only if these two binary inputs do **not** share a common potential. Otherwise this external potential bridge, together with device-internal circuits, can produce incorrect test results.

WIC1 Settings

The "TC" (Trip Coil) output is always mapped to the trip command, i. e. to the digital signal »Prot . TripCmd«. (See also [5.1 »Prot« - General Protection Module](#).)

For measuring the trip delay, the "FI" (Flag Indicator) output is set as follows:

- [Device Para / WIC1 / Output] »Prot . Out. assign.« = "Prot . Pickup"

Testing Device Settings

Finally, you can use the operating software of your testing device to measure the time-span between the two digital inputs. This is straight-forward for all recent testing devices.



9 Servicing and Maintenance

The entire protection system WIC1 is designed for a maintenance-free period of 25 years, hence there are no specific jobs necessary to be done during the operating life of the relays.

However, very often a periodical check of the protection functionality is required by the end user or by legal directives. Such checks can then be carried out as described in [↪8.1 Commissioning / Protection Test](#).

10 Technical Data

10.1 Technical Data - WIC1

NOTICE!	
	Use a shielded Ethernet patch cable (CAT 3 or higher) for the connection between WIC1 and PC4 adapter or DiggiMEC.
	Use a shielded Ethernet patch cable (CAT 5 or higher) for the 100 Mbit/s Ethernet interface of the WIC1.
Crossover cables must not be used for either application!	

10.1.1 Climatic and Environmental Data

Storage Temperature:	-40°C to +85°C (-40°F to 185°F)
Operating Temperature:	<ul style="list-style-type: none"> • WIC1-1, WIC1-2, WIC1-3: -40°C to +80°C (-40°F to 176°F) • WIC1-4: -40°C to +60°C* (-40°F to 140°F*) <p style="margin-left: 40px;">*70°C/158°F for RS485</p>
Permissible Humidity at Ann. Average:	≤ 75% rel. (on 56 days up to 95% rel.)
Permissible Installation Altitude:	≤ 2000 m (6561.67 ft) above sea level

10.1.2 Housing

Housing (Height / Width / Depth): (see also dimension drawings in ↔3.2 Dimension Drawings)	170 mm (6.693 in.) / 125 mm (4.921 in.) / 39.8 mm (1.567 in.)
Material, Housing:	Aluminum. Cover of terminals: plastic
Weight:	<ul style="list-style-type: none"> • WIC1 (without packaging): approx. 940 g • WIC1 (incl. packaging): approx. 1100 g

10.1.3 Degree of Protection EN 60529

Housing	IP40
Electronic circuit	IP65
Terminals	IP20

10.1.4 Phase Current Measurement

The measuring inputs for phase currents are matching the allocated CTs. Moreover, the power requirement of the relay and the CT output power match.

CAUTION!	
	It is not permissible to connect common CTs with secondary currents of 1 A or 5 A to the measuring inputs.

Nominal frequency:	50 Hz / 60 Hz
Nominal Current (at the CT inputs of the WIC1):	83.33 mA 75 mA at $I_n = 0.9 I_{n,min}$ Remark: These values equal in every respect the nominal current data of the previous/ original version of the WIC1 so that full compatibility is guaranteed.
Max. Measuring Range:	20 × highest rated CT current ($20 \cdot I_{n,max}$)
Capacity:	permanently: 2.5 × highest rated CT current ($2.5 \cdot I_{n,max}$)
Thermal load capacity:	1 s: 25 kA CT primary current
Screws	<ul style="list-style-type: none"> Inputs for WIC1 CTs: M3 slotted, tightening torque 0.5 Nm (4.4 lb·in)

10.1.5 Ground Current Measurement

CAUTION!	
	The measuring input for ground (earth) current is permissible only for a CT with secondary current of 1 A.

Ground Current Input:	
Nominal Current:	1 A
Max. Measuring Range:	Up to 20 x I_n
Capacity:	4 x I_n /continuously
Overcurrent Proof:	50 x I_n / 1 s

Ground Current Input:	
Power Consumption:	$S \leq 0.1 \text{ VA}$

10.1.6 Power Supply

Supply via CTs

- Minimum supply current, 1 Phase: 0.35 $I_{n,min}$
- Minimum supply current, 3 Phases: 0.25 $I_{n,min}$

Auxiliary Power Supply (WIC1-4)

Rated Voltage:	48 ... 230 VAC* 24 ... 250 VDC
Operating Range:	80 ... 110% (*108% for 230 VAC)
Buffer Time in Case of Supply Failure:	$\geq 50 \text{ ms}$ at minimal aux. voltage The device will shut down if the buffer time is expired. Note: communication can be interrupted.
Maximum Power Demand:	$S \leq 2.5 \text{ W}$ (except WIC1-4 with fibre optic)

The auxiliary voltage supply must be protected by an external fuse of:

- 2.5 A time-lag miniature fuse 5 x 20 mm (approx. 1/5 x 0.8 in.) according to IEC 60127
- 3.5 A time-lag miniature fuse 6.3 x 32 mm (approx. 1/4 x 1 1/4 in.) according to UL 248-14

10.1.7 LEDs

LED type:	1 green LED, 2 red LEDs
-----------	-------------------------

10.1.8 Outputs

CAUTION!



It is not allowed to connect any active voltage to the trip coil output or to the output (flag indicator / relay output).

CAUTION!



For a WIC1-4, it is also necessary that the configured operating mode matches the connected hardware!
 (For example, it is not permissible to connect a flag indicator and set the operating mode to "Syst. O.K. & Ext.Suppl.". See also the related Self-Supervision warnings [SW 3](#), [SW 4](#).)

Moreover, the electrical energy that an output relay drains with operating mode "Syst. O.K. & Ext.Suppl." requires that the WIC1-4 is supplied by an external auxiliary voltage.

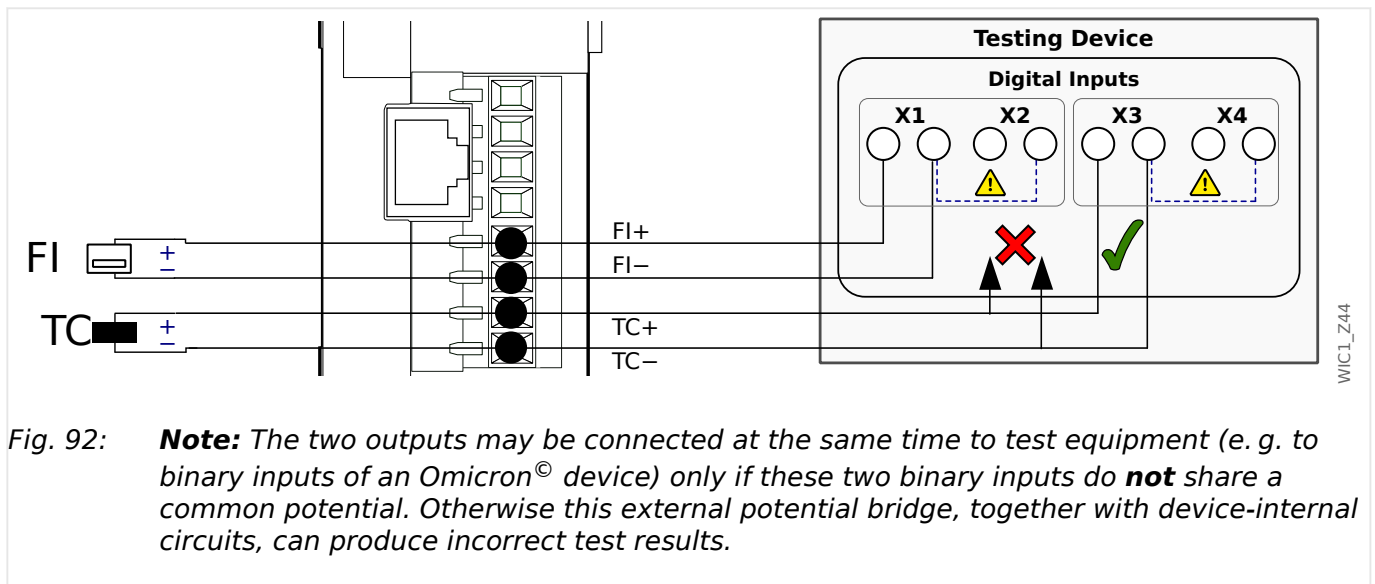

Fig. 92: **Note:** The two outputs may be connected at the same time to test equipment (e. g. to binary inputs of an Omicron[®] device) only if these two binary inputs do **not** share a common potential. Otherwise this external potential bridge, together with device-internal circuits, can produce incorrect test results.

10.1.8.1 Impulse Output for the Tripping Coil

The low-energy trip coil of the circuit breaker is connected to terminals TC+ and TC– of the terminal block X4. The trip energy is provided by a capacitor store integrated in the protection relay. See also [↔5.1.1.1 Trip Pulse and WIC1 LEDs](#).

Length of each trip impulse:	(approx.) 50 ms The pause between the individual pulses depends on the impedance of the tripping coil and the current level. Pulsing is continued until the protection function's tripping state drops off.
Trip energy:	$E \geq 0.1 \text{ Ws}$
Voltage:	24 VDC nominal voltage

Examples for compatible low energy trip coils:

- Manufacturer Siemens, type: 3AX 1104-0B; (0.1 Ws; 10 Ω)
- Manufacturer Siemens, type: 3AX 1104-2B; (0.1 Ws; 20 Ω)

10.1.8.2 Impulse Output for a Flag Indicator

Depending on the [order option](#), the WIC1 can feature an impulse output for a flag indicator.

A flag indicator can be connected to terminals FI+/- (WIC1-4: Out+/-) of the terminal block X4, e. g. for a power-safe signaling of a trip. See also [↔3.10.3 Impulse Signal for the Flag Indicator](#).

Length of each trip impulse:	(approx.) 50 ms The pause between the individual pulses depends on the impedance of the flag indicator and the current level. Pulsing is continued until the protection function's tripping state drops off.
Energy:	≥ 0.01 Ws
Voltage:	24 VDC nominal voltage

10.1.8.3 Relay Output (WIC1-4)

With the device variant WIC1-4, it is possible via setting [Device Para / WIC1 / Output] »*Prot. Out. Mode*« = "Syst. O.K. & Ext.Suppl." to set the output "Out+/-" up for connecting an external output relay.

This output relay must fulfill the following conditions:

Nominal voltage of the coil:	24 VDC, max. 36 VDC No internal overvoltage protection allowed
Input current:	max. 10 mA
Wiring length:	max. 5 m

Example of a usable output relay: Phoenix Relay Module - RIF-0-RSC-24DC/21 - 2903374

10.1.9 Remote (External) Trip Input / Digital Input (WIC1-1, WIC1-2, WIC1-3)

A device of type WIC1**1**, WIC1**2**, WIC1**3** can feature a Digital Input (depending on the [order option](#)).

To the terminals X4-2, X4-3, X4-4 (for the connection of 230 VAC, 115 VAC, COM, resp., see [↔3.5 Digital Input \(only WIC1-1... / WIC1-2... / WIC1-3...\)](#)) of the terminal block X4 the relevant signaling AC voltage for the input is connected. This input is electrically isolated.

CAUTION!	
	<p>It is not allowed to connect any continuous voltage to the 115 VAC or 230 VAC input!</p> <p>Any continuous voltage can destroy the internal signal transformer.</p>

Input voltage range, 115 Volt terminal:	<ul style="list-style-type: none"> If operated up to max. 3000 m (above sea-level): 115 VAC ± 15%
Input voltage range, 230 Volt terminal:	<ul style="list-style-type: none"> 230 VAC ± 15% (d. h. 195,5 V ... 264,5 V) <p>An operation above 3500 m (above sea-level) is outside the specifications and therefore not permitted.</p>
Terminals:	Screw-type terminal
Reaction Time:	<ul style="list-style-type: none"> < 20 ms (*)
Tripping time of the External Protection in case of a cold restart:	≤ 0.5 s

(*) The reaction times have been measured with a WIC1 that is ready to trip (i. e. green Ready LED is lit). They are the time-span for the [External Protection](#) from activation of the trigger signal until activation of the “TC+/-” impulse output.

10.1.10 Digital Inputs (WIC1-4)

A device of type WIC1-4 can feature 2 Digital Inputs (depending on the [order option](#)). For variants WIC1-4xxxxxFxxxx there is a fixed assignment to “External Trip” and “External Reset”, respectively. For variants WIC1-4xxxxxCxxxx, this is a default assignment that can be re-defined.

The Digital Inputs of the WIC1-4 are **not potential-free** with each other, but always related to the “COM” terminal (see [↔3.6 Additional Power Supply and Digital Inputs \(WIC1-4... only\)](#)). The voltages used at the Digital Inputs and the Dual Power Input must have the same nominal voltage. **AC voltages at the Digital Inputs must also be 110 VAC or higher.**

In contrast to the inputs of the WIC1-1/2/3 (see [↔10.1.9 Remote \(External\) Trip Input / Digital Input \(WIC1-1, WIC1-2, WIC1-3\)](#)), the inputs of the WIC1-4 do not have any time restrictions for applied voltages.

The input voltage range can be selected by software parametrization.

Voltage Range	Nominal Voltage	Digital "Low" / "0" below 0.4 Vn (20% below switching threshold)	Switching Threshold at 0.6 Vn (± 20%)	Digital "High" / "1" above 0.8Vn (20% above switching threshold)
24 VDC	24.0 VDC	9.6 VDC	14.4 VDC	19.2 VDC
48 VDC ... 60 VDC	52.0 VDC	20.8 VDC	31.2 VDC	41.6 VDC
110 VDC / 110 VAC	110.0 VDC / 110.0 VAC	44.0 VDC / 44.0 VAC	66.0 VDC / 66.0 VAC	88.0 VDC / 88.0 VAC
230 VDC / 230 VAC	220.0 VDC / 220.0 VAC	88.0 VDC / 88.0 VAC	132.0 VDC / 132.0 VAC	176.0 VDC / 176.0 VAC

Terminals:	Screw-type terminal
Rated Voltage:	110 / 230 VAC* 24 ... 230 VDC
Operating Range:	80 ... 110% (*108% for 230 VAC)
Max. Input Voltage:	300 VDC / 250 VAC
Max. Power Demand:	2.5 W (6 W for Optical Ethernet)
Reaction Time:	<ul style="list-style-type: none"> • for DC: < 20 ms (*) • for AC: < 30 ms (*)

(*) The reaction times have been measured with a WIC1 that is ready to trip (i. e. green Ready LED is lit). They are the time-span for the [External Protection](#) from activation of the trigger signal until activation of the "TC+/-" impulse output.

10.1.11 Terminal X6: RS485 (WIC1-4)

Check the [order options](#) for availability of an RS485 connector for your device variant.

Note that [SCADA communication](#) can only be used with an external power supply.

Connection:	<p>6 screw-clamping terminals RM 3.5 mm (138 MIL) (terminating resistors internal)</p> <p>Tightening Torques of the Screws: See ↔3.1.1 Terminals, Screws and Torques.</p> <p>Device-internal connections: See ↔Fig. 29.</p>
Transmission Speed: (Modbus RTU)	<ul style="list-style-type: none"> • 57.6K baud • 115.2K baud

CAUTION!



In case that the RS485 interface has terminals, the communication cable has to be shielded.

10.1.12 Terminal X7: Ethernet Interface (WIC1-4)

Check the [order options](#) for availability of an Ethernet interface ([RJ45](#) or [fiber optic](#)) for your device variant.

Note that [SCADA communication](#) can only be used with an external power supply.

NOTICE!



Ethernet-related software modules, in particular »TCP/IP« and »Modbus TCP«, are carried out by a co-processor, i. e. a second CPU. This unburdens the main CPU and thus stabilizes all protection functionality. Even in the extreme case that the TCP/IP communication should crash, would all protection modules continue with full functionality.

For the Modbus TCP communication, however, this recommends that the user keeps in mind the times described in [↔“Cycle Times with Modbus TCP and RTU”](#).

10.1.12.1 RJ45 connector (Terminal X7,WIC1-4)

Check the [order options](#) for availability of an RJ45 connector for your device variant.

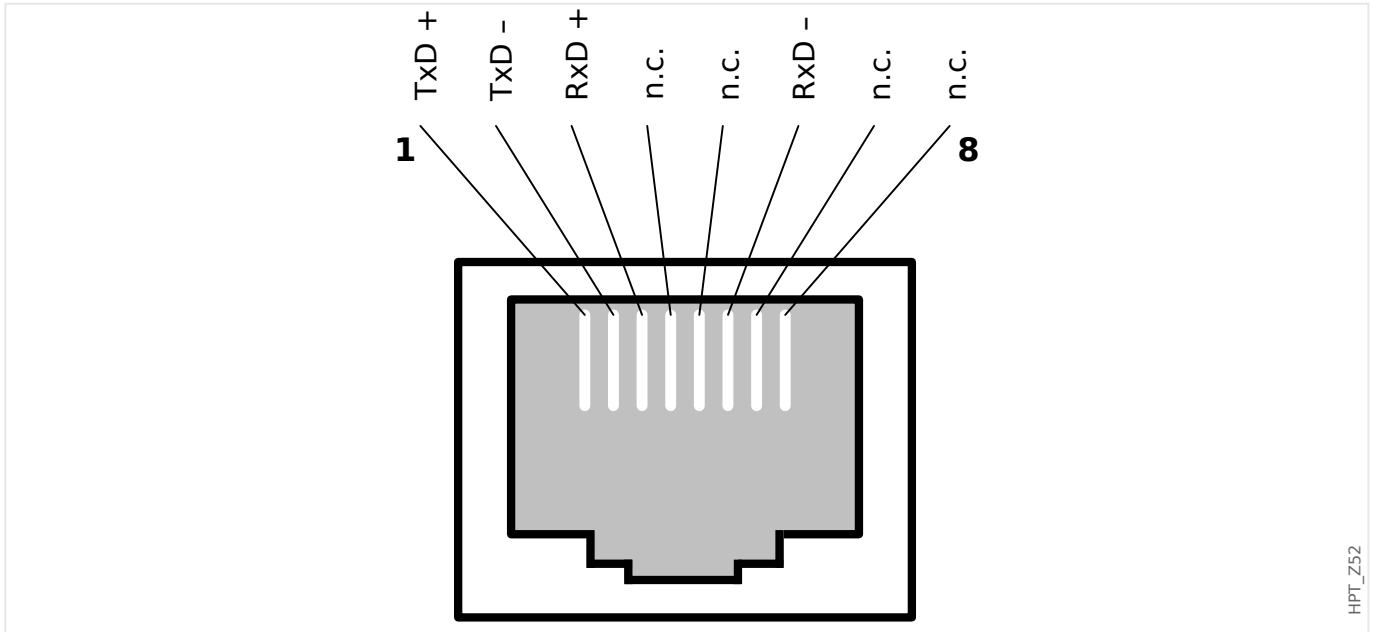

HPT_Z52

Connector:	RJ45
Transmission Rate:	100 Mbit/s
Maximum Link Length:	100 m

NOTICE!



RJ45 cables with an excessively large latching lug protection cannot be installed when using the WIC1 plastic cover for the side terminals. Therefore, it is recommended to use RJ45 cables without latching lug protection for the X7 interface. (see also [↪3.8 Ethernet Interface \(RJ45\)](#))

10.1.12.2 Optical Ethernet with LC connector (Terminal X7,WIC1-4)

Check the [order options](#) for availability of a fiber optics interface for your device variant.

Connector:	LC Port, 100BASE-FX
Compatible Fiber:	Multimode; 50/125 µm and 62.5/125 µm
Wavelength:	1300 nm
Minimum Optical Input Power:	-30.0 dBm
Minimum Optical Output Power:	-22.5 dBm with 50/125 µm fiber -19.0 dBm with 62,5/125 µm fiber
Maximum Link Length:	approx. 2 km (depending on link attenuation)

10.1.13 Smart view Connections

The WIC1 can communicate with the operating software *Smart view* via a USB connection to a PC4 adapter or DiggiMEC. (See also [↔2.2.1 PC via Smart view and DiggiMEC \(HMI\)](#))

PC4 adapter or DiggiMEC must be ordered separately (see [↔2.6.1.6 Order Form of the PC4 adapter](#) and [↔2.6.1.7 Order Form of the DiggiMEC](#)). *Smart view* can be directly downloaded (free of costs) and installed on a Windows PC: http://docs.segelectronics.de/smart_view

- Use a standard network (Ethernet) cable to connect the WIC1 with the PC4 adapter or DiggiMEC. (See [↔3.12 PC4 adapter - PC Interface for WIC1](#) and [↔3.13 DiggiMEC® - Nano HMI with optional Flag Indicators and Output Relays](#))

(Note, however, that the communication between WIC1 and PC4 adapter / DiggiMEC is based on a proprietary protocol.)

10.1.14 Self-Supervision Messages

The storage capacity for Self-Supervision messages (see [↔7.2 Self-Supervision Messages](#)) is as follows:

- **E** - Errors - up to 37 messages. Each new error beyond this number deletes the oldest error message.
- **W** - Warnings - up to 25 messages. Each new warning beyond this number deletes the oldest warning message.
- **I** - Information messages - up to 25 messages. Each new information message beyond this number deletes the oldest information message.

10.2 Tolerances / Accuracy - WIC1

NOTICE!



The tripping delay relates to the time between alarm and trip. The accuracy of the operating time relates to the time between fault entry and the time when the protection element is picked-up.

10.2.1 Protection Elements Accuracy

The specified tolerances for the protection modules only apply under the following reference conditions:

- sine wave at rated frequency (50 Hz / 60 Hz),
- THD < 1%, measuring method: fundamental,
- Power supply (device is ready to trip):
 - via phase CTs: minimum current > $0.35 \cdot I_{n,min}$ for at least 1 s (3ph) or 5 s (1ph)
 - or external: with auxiliary voltage (only WIC1-4).

If the device is supplied exclusively via the CTs and **not** running / ready to trip when the fault occurs (cold start), the specified start and operating times may be longer. For more information refer to [↔10.2.2 Operating Times at Cold Start \(CT supplied\)](#).

Tolerances related to phase current measurement always apply to the system consisting of the WIC1 itself and the [WIC1 CTs](#).

10.2.1.1 Phase Overcurrent Protection

Overcurrent Protection Stages	Accuracy
I>, I>>, I>>>	
Pickup value »I« for $I > 0.35 I_{n,min}$ *2) and $I < 3 I_{n,min}$ *3)	$\pm 5\%$ of the setting value or $\pm 5\% I_n$.
Dropout Ratio	95%

Overcurrent Protection Stages <i>I>, I>>, I>>></i> Definite time »Char« = "DEFT"	Accuracy
Tripping delay*1) »t«	±1% or ±10 ms
Start time (pickup time) or operate time (for »t« = 0 ms) at testing current ≥ 2 times pickup value	50 Hz: <30 ms (17 ms typical) 60 Hz: <27 ms (14 ms typical)
Disengaging Time	<50 ms

Overcurrent Protection Stages <i>I>, I>>, I>>></i> Inverse-Time / Characteristic curve	Accuracy
Start time (pickup time) At testing current ≥ 2 times pickup value	50 Hz: <30 ms (17 ms typical) 60 Hz: <27 ms (14 ms typical)
Tripping delay*1) For testing current in the range 2 ... 20 times pickup value	±5% or ±30 ms (according to the selected curve, see ↪12.2.1 Characteristics (<i>I>, I>>, I>>></i>))
Operate time	= Start time + Tripping delay
Disengaging Time	<50 ms

*1) if the protection stage is used together with **Inrush Blocking** it is necessary to set the tripping delay to at least 30 ms.

*2) Except:

- **WIC1-W2AS1** (W2 Construction Type 1),
WIC1-WE2AS1 (WE2 Construction Type 1),
WIC1-W2AS1 (W2 Construction Type 2):
 - $I > 0.6 I_{n,min}$: 5% »l« or I_n
 - $0.35 I_{n,min} < I < 0.6 I_{n,min}$: 17.5% »l« or I_n
- **WIC1-WC2** Converter CT:
 - $I > 0.25 I_n$: 5% »l« or I_n
 - $0.1 I_n < I < 0.25 I_n$: 7.5% »l« or I_n

*3) For $I > 3 I_{n,min}$, accuracy is ±7.5% of the setting value.

10.2.1.2 Ground (Earth) Overcurrent Protection

(Measurement of ground (earth) current is not available for all device variants.)

Ground (Earth) Current Protection Stages IG>, IG>>	Accuracy
Pickup value »IG« for measured ground (earth) current and IG within 0.02 ... 10 In:	±2% of the setting value or ±2% In.
Pickup value »IG« for calculated ground (earth) current and I within 0.35 ... 10 In *4)	<ul style="list-style-type: none"> • ±3% of the greatest phase current value or ±9% of the setting value. • with setting »Measuring method« = "True RMS": ±15% of the setting value.
Dropout Ratio	95%

Ground (Earth) Current Protection Stages IG>, IG>> Definite time »Char« = "DEFT"	Accuracy
Tripping*1) delay »t«	±1% or ±10 ms
Operate time (for »t« = 0 ms) at testing current ≥ 2 times pickup value	50 Hz: <40 ms (21 ms typical) 60 Hz: <37 ms (18 ms typical)
Disengaging Time	<50 ms

Ground (Earth) Current Protection Stages IG>, IG>>	Accuracy
Inverse-Time / Characteristic curve	
Start time (pickup time)	50 Hz: <40 ms (21 ms typical)
At testing current ≥ 2 times pickup value	60 Hz: <37 ms (18 ms typical)
Tripping delay ^{*1)} For testing current in the range 2 ... 10 times pickup value and $I = 0.5 \dots 2 I_n$	$\pm 9\%$ or ± 40 ms (according to the selected curve, see ↔12.2.2 Characteristics (IG>, IG>>))
Operate time	= Start time + Tripping delay
Disengaging Time	<50 ms

*1) if the protection stage is used together with [Inrush Blocking](#) it is necessary to set the tripping delay to at least 30 ms.

*4) The calculated ground current values are released if there is at least $0.25 \cdot I_{n,min}$ in all 3 phases or at least $0.35 \cdot I_{n,min}$ in one phase, otherwise the value is assumed as 0.

10.2.1.3 Unbalanced Load [46], Negative-Sequence Current Protection [51Q]

Protection Stage I2>	Accuracy
Pickup value »I2« for I within 0.5 ... 2 In	±6% of the setting value or ±3% of the greatest phase current value.
Dropout Ratio	95%

Protection Stage I2/I1>	Accuracy
Pickup value »I2/I1« *5) for I within 0.5 ... 2 In	±2% (absolute)
Dropout Ratio	95%

Protection Stages I2/I1>, I2> Definite time (»Char« = "DEFT")	Accuracy
Tripping delay*1) »t«	±1% or ±10 ms
Operate time (for »t« = 0 ms) at testing current ≥ 2 times pickup value	50 Hz: <70 ms (39 ms typical) 60 Hz: <67 ms (33 ms typical)
Disengaging Time	<50 ms

Protection Stage I2> Inverse-Time / Characteristic curve	Accuracy
Start time (for »t« = 0 ms) at testing current ≥ 2 times pickup value	50 Hz: <70 ms (39 ms typical) 60 Hz: <67 ms (33 ms typical)
Tripping delay*1) For testing current in the range 2 ... 10 times pickup value	±6% or ±70 ms (according to the selected curve, see ↪12.2.3 Characteristics »I2>«)
Operate time	= Start time + Tripping delay
Disengaging Time	<50 ms

*1) if the protection stage is used together with **Inrush Blocking** it is necessary to set the tripping delay to at least 30 ms.

*5) The measuring value $I2/I1$ is released under the conditions $I1 > 20\% I_n$ and $I2 > 0,5\% I_n$, otherwise it is assumed as 0.

10.2.1.4 Peak Overcurrent Protection

Peak Overcurrent Protection I_{peak}	Accuracy
Pickup value $\gg I \ll$	$\pm 10\%$ of the setting value
Tripping delay ^{*1)} $\gg t \ll$	$\pm 1\%$ or ± 10 ms
Operate time (for $\gg t \ll = 0$ ms) at testing current ≥ 2 times pickup value	50 Hz: < 20 ms (7 ms typical) 60 Hz: < 17 ms (7 ms typical)
Disengaging Time	< 50 ms

10.2.1.5 Inrush Blocking

Inrush Blocking I_{H2}	Accuracy
Pickup value $\gg I_{H2} / I_{H1} \ll$ ^{*6) *7)} for I within the range $0.5 \dots 2 I_n$	$\pm 2\%$ absolute
Blocking of the Inrush Blocking based on a short-circuit current Starting threshold $\gg I_{max} \ll$ ^{*8)}	$\pm 15\%$ of the setting value
Time limit of the blocking Timer $\gg I_{H2} . t_{max} \ll$	$\pm 5\%$ or ± 30 ms

*6) The tripping delay must be at least 30 ms for all protection stages that shall be stabilized by the Inrush Blocking.

*7) The measuring value I_{H2} / I_{H1} is released under the conditions $I_{H1} > 0,3 I_n$ and $I_{H2} > 0,03 I_n$, otherwise it is assumed as 0.

*8) If the limit current $\gg I_{max} \ll$ is used then the threshold should be at least 15% below the current threshold of the protection stage that shall not be blocked in case of a short-circuit current.

10.2.1.6 Switch Onto Fault (SOTF)

The accuracy and tripping times depend on the protection function that triggers the SOTF.

In case of the smallest possible setting values and SOTF tripping delay $\gg t_{\ll} = 0$ ms, it is possible to reach the following accuracy for switching onto a 3-pole short-circuit when the WIC1 is self-powered:

Switch Onto Fault SOTF	Accuracy
Tripping delay $\gg t_{\ll}$	$\pm 1\%$ or ± 10 ms
Operate time (for $\gg t_{\ll} = 0$ ms)	The operating time depends on the respective protection stage that triggers the SOTF function (Assignment to [Protection Para / SOTF] $\gg SOTF . Trigger_{\ll}$).

10.2.1.7 Thermal Overload Protection

These tolerances are valid for $K \cdot I_b \geq 1.0$.

Thermal Overload Stage ThR	Accuracy
$K \cdot I_b$	$\pm 5\%$ of the setting value or $\pm 5\% I_n$.
Tripping delay according to the equation in \leftrightarrow "Tripping Time" in cold state (i. e. without previous warming)	$\pm 5\%$ of the calculated value or ± 1 s.
Limiting error as multiple of assigned error	<ul style="list-style-type: none"> • $I = 1.2 \dots 1.4 K \cdot I_b$: $2.0 \triangleq 10\%$ • $I = 1.4 \dots 1.6 K \cdot I_b$: $1.5 \triangleq 7.5\%$ • $I = 1.6 K \cdot I_b \dots I_{\max}^{(*)}$: $1.0 \triangleq 5\%$ <p>(*) I_{\max} depends on the maximum short circuit current which can be measured, see also \leftrightarrow Table .</p>

10.2.1.8 External Protection

External Protection Exp	Accuracy
Tripping delay »t«	±1% or ±10 ms
Operate time (for »t« = 0 ms)	<ul style="list-style-type: none">• With active power supply (device is ready to trip):<ul style="list-style-type: none"><30 ms (typical 20 ms) in case of AC signaling<20 ms (typical 8 ms) in case of DC signaling• Cold start*⁹⁾ and the device is powered via the digital input only:<ul style="list-style-type: none"><500 ms

*⁹⁾ For a cold start of the WIC1, the operate time is mainly characterized by the charging time of the capacitors for the trip pulse.

10.2.2 Operating Times at Cold Start (CT supplied)

If the device is supplied exclusively via the CTs and **not** running / ready to trip when the fault occurs (cold start), the specified start and operating times may be longer. In this case the device must first start up and charge its energy storages so that sufficient energy is available for a trip pulse.

A higher number of active phases with current flow and higher current amplitudes result in a faster charging process and therefore reduce start and operating times.

Limitations

Start and operating times are not increased if the device is supplied sufficiently and has loaded its energy storages. This applies for the following conditions:

- Phase CT supplied: minimum current $> 0.35 \cdot I_{n,min}$ for at least 1 s (3ph) or 5 s (1ph).
- External supply: with auxiliary voltage (only WIC1-4).

The operating times shown below only apply to a limited extent if a time delay $\gg t_{\ll} > 0$ is set for the protection stage. In this case, the charging of the energy storages and the time delay run in parallel. Depending on the length of the configured time delay, the charging time then has little or no influence on the total operating time.

Results

The influence of the start up and energy storage loading is shown for the Phase Overcurrent Protection in the following. The measurements were carried out under the following conditions:

- 1-/3-phase fault currents
- $f_N = 50$ Hz
- $I_n = I_{n,min}$
- Definite-time overcurrent ($\gg Char \ll = "DEFT"$).
- Without additional trip delay ($\gg I > . t_{\ll} = 0$).
- Measured from power off until trip impulse signal.
- Blue curve in the diagram below: 1 phase, 15 tests for each current value. Red curve: 3 phases, 5 tests for each current value.

The results are comparable for 60 Hz nominal frequency and for the times of other protection modules.

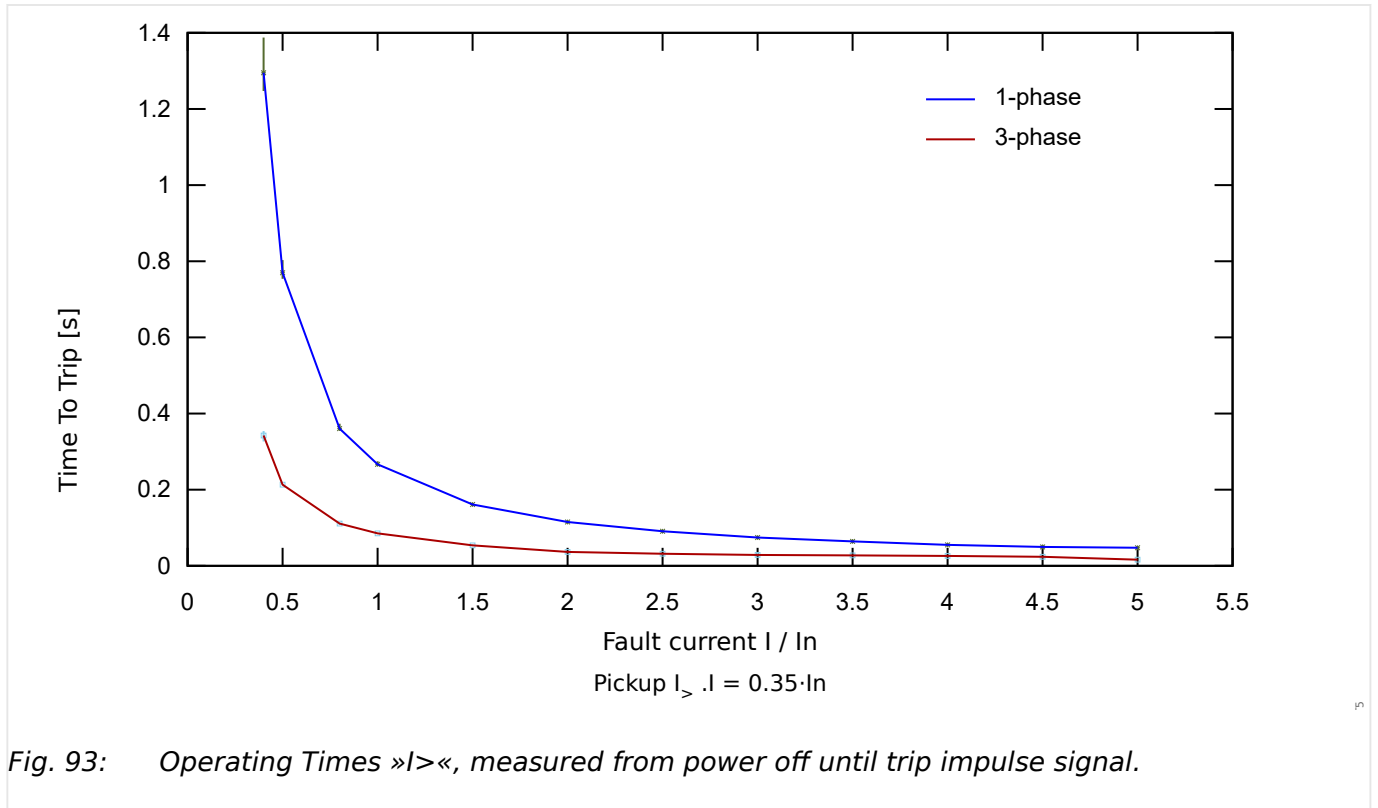

Pickup Setting I [In]	I [In]	Average Measured Trip Times [ms]	
		1-phase	3-phase
0.35	0.4	1295	342
	0.5	770	213
	0.8	360	111
	1.0	267	85
	1.5	161	54
	2.0	115	37
	2.5	90	32
	3.0	74	29
	3.5	64	27
	4.0	55	26
	4.5	50	24
	5.0	48	16

10.3 Technical Data - PC4 adapter

NOTICE!



Use an Ethernet cable CAT 3 (or better) with shielding for the connection between WIC1 and PC4 adapter. **Crossover cables must not be used!**

The maximum permissible length of the Ethernet cable is 10 m.

Dimensions (L x W x H):	approximately 85 mm x 50 mm x 22 mm
Weight:	approximately 51 g
Interfaces:	<ul style="list-style-type: none"> • RJ45 connector: Connection to WIC1 device • USB-C connector: Connection to a PC or laptop USB-A port

Transmission

Maximum transmission speed on UART side:	57.6K baud
Maximum transmission speed on USB side:	12 Mbit/s (according to USB 2.0 standard)

Temperature

Ambient operating temperature:	-20°C ... +70°C
Storage temperature:	-40°C ... +85°C

Approvals

- EN 61000-4-2
- EN 61000-4-3
- EN 61000-4-4
- EN 61000-4-6
- EN 61000-6-2
- EN 61000-6-3

10.4 Technical Data - DiggiMEC

NOTICE!



Use copper conductors only, 75°C.
Conductor size \leq AWG 14 [2.5 mm²].

NOTICE!



Use an Ethernet cable CAT 3 (or better) with shielding for the connection between WIC1 and DiggiMEC. **Crossover cables must not be used!**
The maximum permissible length of the Ethernet cable is 10 m.

10.4.1 Climatic and Environmental Data

Storage Temperature:	-30°C to +80°C (-22°F to 176°F)
Operating Temperature:	-20°C to +60°C (-4°F to 140°F)
Permissible Humidity at Ann. Average:	<75% rel. (on 56 days up to 95% rel.)
Permissible Installation Altitude:	\leq 2000 m (6561.67 ft) above sea level

10.4.2 Housing

Housing (Height / Width / Depth):	53 mm / 102 mm / 55,8 mm (see also dimension drawings in ↪3.2.2 DiggiMEC Dimension Drawings)
Door cutout (Height / Width):	45 mm / 92 mm
Material, Housing:	Plastic
Weight:	<ul style="list-style-type: none">• DiggiMEC-0: approx. 130 g• DiggiMEC-A: approx. 160 g• DiggiMEC-B: approx. 190 g• Packaging: approx. 140 g

10.4.3 Degree of Protection EN 60529

Front panel with seal	IP52
Front panel without seal	IP50
Rear side terminals	IP20

10.4.4 Voltage Supply

Supply via WIC1 CTs

With the setting »Operation Preference« = “Early wake-up”:

- 1-phase wakeup = 0.6 I_n ,min
- 3-phases wakeup = 0.4 I_n ,min

With the setting »Operation Preference« = “Precise meas.”:

- 1-phase wakeup = 1.1 I_n ,min
- 3-phases wakeup = 0.75 I_n ,min



Since the setting »Operation Preference« = “Early wake-up” results in less accurate measurement values it is recommended in general to keep the default value “Precise meas.”.

10.4.5 Binary Output Relays

Continuous current, max. switching current:	1 A AC
Max. switching voltage:	250 VAC
Contact type:	1 or 3 bistable relays, depending on device type: <ul style="list-style-type: none"> • DiggiMEC-A: <ul style="list-style-type: none"> 1 normally open (Form A) contact • DiggiMEC-B: <ul style="list-style-type: none"> 1 changeover contact, 2 normally open (Form A) contacts
Terminals:	Screw-type terminals

10.4.6 Standards - DiggiMEC

10.4.6.1 Approvals

	
	
	<p>UL File Nr.: E217753</p> <p>cULus Certification of WIC1 and DiggiMEC - UL508, E217753 - NRGU</p>

10.4.6.2 Design Standards

<p>Generic standards</p>	<p>EN 61000-6-2 [2019]</p> <p>EN 61000-6-3 [2022]</p>
<p>Product standards</p>	<p>IEC 60255-1 [2009]</p> <p>IEC 60255-26 [2013]</p> <p>IEC 60255-27 [2013]</p>

10.4.6.3 Electrical Tests

EMC Tests

Electrical Discharge Immunity Test (ESD)

IEC 60255-26 [03/14]	Air discharge	8 kV
DIN EN 61000-4-2 [12/09] class 3	Contact discharge	6 kV

Fast Transient Disturbance Immunity Test (Burst)

IEC 60255-26 [03/14]	Power supply, mains inputs	± 4 kV, 2.5 kHz
DIN EN 61000-4-4 [04/13] class 4	Other in- and outputs	± 2 kV, 5 kHz

Interference immunity against 1 MHz burst disturbance tests

IEC 60255-26 [03/14]	differential mode	2.5 kV, 1 MHz
DIN EN 61000-4-18 [09/20]	common mode	1 kV, 2 s

Interference immunity against surge immunity test

IEC 60255-26 [03/14]		4 kV / 2 kV
DIN EN 61000-4-5 [03/19]		

Interference immunity against high-frequent electromagnetic fields

IEC 60255-26 [03/14]		30 V/m
DIN EN 61000-4-3 [04/11]		

Interference immunity against magnetic fields of energy based frequency

IEC 60255-26 [03/14]	continuously	100 A/m
DIN EN 61000-4-8 [11/10]	3 s	1000 A/m

Interference immunity against line conducted interference quantities induced by high-frequent fields

IEC 60255-26 [03/14]		10 V/m
DIN EN 61000-4-6 [08/14]		

Interference immunity against surge voltage

IEC 60255-26 [03/14]	within a current circuit	1 kV
IEC 60255-27 [11/14]	current circuit to earth	5 kV

Measuring of the radio interference voltage

DIN EN 55011 [05/18]		Limit value class B
----------------------	--	---------------------

Measuring of the radio interference radiation

DIN EN 55011 [05/18]		Limit value class B
----------------------	--	---------------------

10.4.6.4 Safety-Related Tests

Overvoltage category	IEC 60255-27 [11/14]	III
Pollution degree	IEC 60255-27 [11/14]	3
Protection class	IEC 60255-27 [11/14]	II
Test of withstand alternating voltage for 1 min	IEC 60255-27 [11/14]	4 kV / 1 kV
Test of lightning surge voltage 1.2/50 μ s, 0.5 J	IEC 60255-27 [11/14]	5 kV / 1 kV
Inflammability	IEC 60255-27 [11/14]	rated
Single Defect Condition	IEC 60255-27 [11/14]	rated

10.4.6.5 Environmental Tests

Vibration and continuous vibration test:	IEC 60255-27 [11/14]	0.5 / 1 gn
	DIN EN 60255-21-1 [05/96]	Class 2
Shock and continuous shock test:	IEC 60255-27 [11/14]	5 / 10 gn
	DIN EN 60255-21-2 [05/96]	Class 2

Classification:		
IEC 60255-27 [11/14]	Climate category	20/060/10
DIN EN 60068-1 [09/15]		

Test Ad: Kälte		
IEC 60255-27 [11/14]	Temperature	-20°C
DIN EN 60068-2-1 [01/08]	Period of stress	16 h

Test Bd: Dry heat		
IEC 60255-27 [11/14]	Temperature	+60°C (140°F)
DIN EN 60068-2-2 [07/07]	Rel. humidity	<50%
	Period of stress	72 h

Test Cab: Humid heat (constantly)		
IEC 60255-27 [11/14]	Temperature	+60°C (140°F)
IEC 60068-2-78 [02/14]	Rel. humidity	93%
	Period of stress	10 Tage

Test Db: Humid heat (cyclic)		
IEC 60255-27 [11/14]	Temperature	+60°C (140°F)
IEC 60068-2-30 [06/06]	Rel. humidity	95%
	Cycles (12 + 12 hours)	2

10.5 Technical Data - WIC1 CTs

CT types and respective order codes: See [↔2.6.1.3 Order Form of the WIC1-Compatible Current Transformers](#).

Dimensions: See [↔3.2.3 Dimension Drawings of the WIC1-Compatible Current Transformers](#).

10.5.1 Technical Data - WIC1-Wx CTs, Construction Type 2

WIC1-Wx CT (Construction Type 2)		Transformer Ratio	Prim. Rated Current Range	Test wiring	Weight
WE2	WIC1-CT2-5P	16 A / 0.083 A (14.4 A / 0.075 A)	16 ... 56 A	1 A / 50 A	ca. 2.9 kg
W2	WIC1-CT2-10P	16 A / 0.083 A (14.4 A / 0.075 A)	16 ... 56 A	1 A / 50 A	ca. 2.4 kg
W3	WIC1-CT3	32 A / 0.083 A (28.8 A / 0.075 A)	32 ... 112 A	1 A / 100 A	ca. 2.1 kg
W4	WIC1-CT4	64 A / 0.083 A (57.6 A / 0.075 A)	64 ... 224 A	1 A / 200 A	ca. 1.8 kg
W5	WIC1-CT5	128 A / 0.083 A (115.2 A / 0.075 A)	128 ... 448 A	1 A / 400 A	ca. 1.8 kg

WIC1-CT2-5P, WIC1-CT2-10P, WIC1-CT3, WIC1-CT4, WIC1-CT5	
Standards:	IEC 61869-1, IEC 61869-2. Fire resistance according to UL94 V-0
Insulation peak voltage:	0.72 / 3 / - kV
Insulation class:	E
Accuracy class:	5P80 (WIC1-CT2-10P: 10P80)
Nominal frequency:	50 Hz / 60 Hz
Rated continuous thermal current:	extd. 1000%
Rated short-time thermal current I_{th} :	21 kA for 3 s, or 25 kA for 1 s
Peak current:	$I_{dyn} = 2.5 \cdot I_{th}$
Ambient temperature:	-40°C ... +85°C (-40°F ... 185°F)
Primary window suitable for cable:	max. \varnothing 50 mm
Material:	Thermoplast housing filled with polyurethane resin. The housing is flame resistant and free from halogen.
Secondary terminal:	Screw connection, M3 screws for wires with section up to 4 mm ²

Measured Winding Resistance at 23°C (73°F)		
WE2	WIC1-CT2-5P	2.8 Ω
W2	WIC1-CT2-10P	2.1 Ω
W3	WIC1-CT3	4.1 Ω
W4	WIC1-CT4	4.0 Ω

Measured Winding Resistance at 23°C (73°F)		
W5	WIC1-CT5	7.9 Ω

10.5.2 Technical Data - WIC1-Wx CTs, Construction Type 1

WIC1-Wx CT (Construction Type 1: WIC1-WE2AS1, WIC1-W2AS1, ... , WIC1-W6AS1)	
Standard:	IEC 61869-2
Protection degree:	IP20
Insulation class:	E (120°C)
Accuracy class:	5P80 (WIC1-W2AS1: 10P80)
Nominal frequency:	50 Hz / 60 Hz
Rated short-time thermal current I_{th} :	20 kA for 1 s, or 25 kA for 1 s
Ambient temperature:	-5°C to +40°C (23°F to 104°F)
Primary window suitable for cable:	max. ø 50 mm
Material:	PU, PA6.6
Secondary terminal:	6 mm ² solid / 4 mm ² stranded, screw connection
Test wiring rated current:	0.288 A

10.5.3 Maximum Cable Length for the WIC1-Wx CTs

The maximum allowed impedance of the cable connections (i. e. the sum for both contacts) between WIC1 and CT is **1.5 Ω**.

From this follows that for a usual copper cable with 0.5 mm² cross-section (and typical ambient temperatures) a maximum length of **22 meters** per cable is allowed.

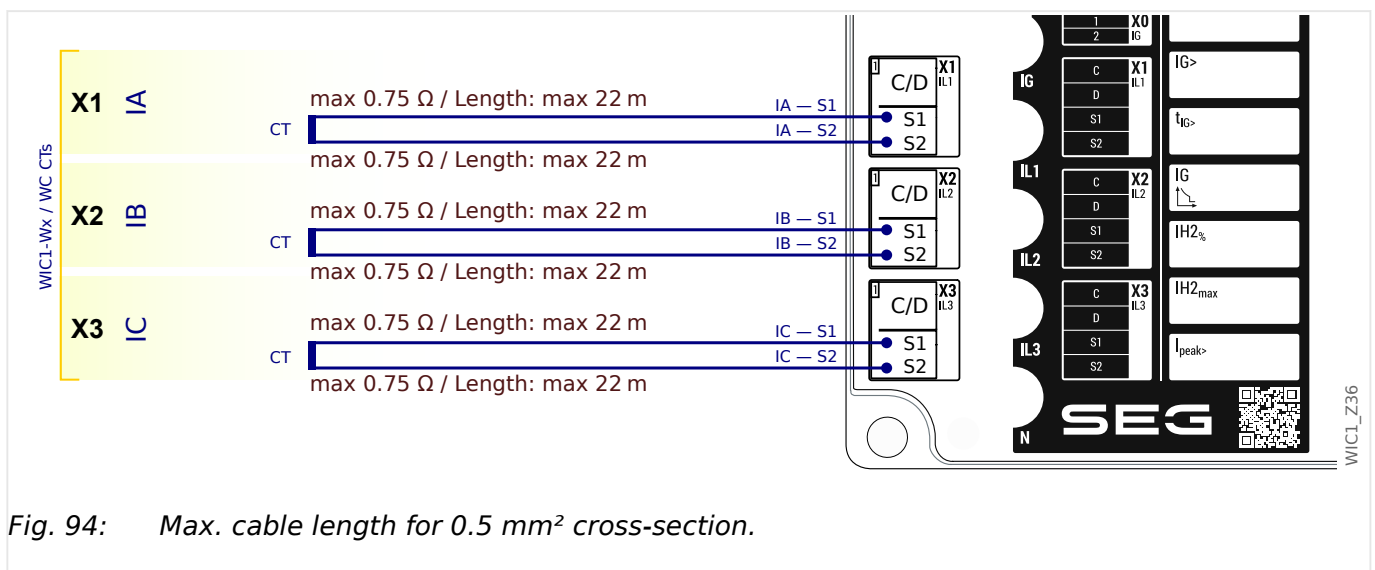

Fig. 94: Max. cable length for 0.5 mm² cross-section.

10.5.4 Technical Data – WIC1-WC Converter CTs for 1 A, 5 A

WIC1-WC Converter CTs (for 3 phases, combined in 1 housing)		Primary rated current	Secondary rated current	Weight
Converter 1 A → WIC1	WIC1-WC1-1A:	1 A	0.083 A	ca. 3.65 kg
Converter 5 A → WIC1	WIC1-WC1-5A:	5 A	0.083 A	ca. 3.65 kg
Converter 1 A → WIC1	WIC1-WC2-1A:	1 A	0.290 A	ca. 3.65 kg

WIC1-WC1-1A, WIC1-WC1-5A, WIC1-WC2-1A	
Standard:	IEC 61869-1, IEC 61869-2
Rated insulation level:	0.72 / 3 / - kV
Insulation class:	E
Accuracy class:	WIC1-WC1: 5P80 WIC1-WC2: 5P20
Nominal frequency:	50 Hz / 60 Hz
Rated continuous thermal current:	extd. 120%
Rated short-time thermal current I_{th} :	$I_{th} = 100 \cdot I_r / 1 \text{ s}$
Dynamic current:	$I_{dyn} = 2.5 \cdot I_{th}$
Ambient temperature:	-40°C ... +85°C
Material:	Thermoplast housing filled with polyurethane resin. The housing is flame resistant and free from halogen.
Connections:	2 cables (for input/primary and output/secondary current), length 3000 mm. (The cables may be shortened to fit the given application.)

Maximum Cable Length:

- For the secondary circuit of the standard CTs – i. e. the connections between standard CTs and Converter CTs – the requirements described in [↔12.3 Requirements for 1 A/5 A Standard CTs with WIC1-WC Converter CTs](#) must be fulfilled.
- For the secondary circuit of the Converter CTs – i. e. the connections between Converter CTs and WIC1 – the CTs already have pre-installed cables with a length of 3000 mm. These can be shortened to the desired length.

WARNING!



Due to technical constraints with respect to construction, the Converter CT has a window, just like the feed-through of a standard CT. But it is not permitted to mount an MV / primary current cable through this Converter CT window!

Ignoring this can result in dangerous voltages at the contacts, and due to wrong measuring values there would not be any effective protection of your equipment.

NOTICE!



Please note also these peculiarity, that are inherent to the construction of the Converter CTs:

- The housing (see [↪Fig. 18](#)) contains three Converter CTs, so that all three phase currents are covered. Therefore you need to buy only one unit, see also [↪“WIC1-WC Converter CTs for 1 A or 5 A”](#).
- There are no test windings. Therefore the test sockets of the WIC1 **cannot** be used with the Converter CTs.

10.5.5 Test Windings, Test Sockets

The Converter CTs do not have any test winding, therefore these data are only valid for the WIC1-Wx CTs (construction type 2 or 1).

Please note that the **tolerances** only apply to primary current input. Current infeed via the test inputs may result in lower accuracy.

CT Type	Prim. Current Range <i>In,min</i> ... <i>In,max</i>	Injected C-D Test Current	Induced Current
W2, WE2	16 ... 56 A	1 A	50 A
W3	32 ... 112 A	1 A	100 A
W4	64 ... 224 A	1 A	200 A
W5	128 ... 448 A	1 A	400 A
W6	256 ... 896 A	1 A	800 A

Use of the test windings, especially for higher currents, places high demands on the test equipment. Depending on the amplitude of test current and the selected CT, the test device should be capable to deliver a certain power and voltage. This is shown in [Table 3](#) below.

Generally, it is recommended to switch to single-phase testing for high currents to bundle the power of the test device at one output.

For Omicron[®] CMC 256plus / 356 users: Please note that these devices feature multiple current output modes with different wiring to adapt to the test requirements if high power and voltage are necessary. It is recommended to experiment with these settings if one does not lead to the expected result.

CT Type	Test current [<i>In,min</i>]	Test current at test sockets [A]	Test current primary [A]	Test device power [VA]	Test device voltage [V]
WE2 [16-56 A], Construction Type 2, WIC1-CT2-5P	10	3.2	160	24	8
	35	11.2	560	243	22
	70	22.4	1120	952	43
W2 [16-56 A], Construction Type 2, WIC1-CT2-10P	10	3.2	160	21	7
	35	11.2	560	212	19
	70	22.4	1120	827	37
W3 [32-112 A], Construction Type 2, WIC1-CT3	10	3.2	320	26	8
	35	11.2	1120	266	24
	70	22.4	2240	1044	47
W4 [64-224 A], Construction Type 2, WIC1-CT4	10	3.2	640	28	9
	35	11.2	2240	291	26
	70	22.4	4480	1142	51
W5 [128-448 A], Construction Type 2, WIC1-CT5	10	3.2	1280	44	14
	35	11.2	4480	487	44
	70	22.4	8960	1927	86

CT Type	Test current [In,min]	Test current at test sockets [A]	Test current primary [A]	Test device power [VA]	Test device voltage [V]
WE2 [16-56 A], Construction Type 1, WIC1-WE2AS1	10	3.2	160	28	9
	35	11.2	560	292	27
	70	22.4	1120	1145	52
W2 [16-56 A], Construction Type 1, WIC1-W2AS1	10	3.2	160	23	7
	35	11.2	560	229	21
	70	22.4	1120	894	40
W3 [32-112 A], Construction Type 1, WIC1-W3AS1	10	3.2	320	28	9
	35	11.2	1120	292	27
	70	22.4	2240	1145	52
W4 [64-224 A], Construction Type 1, WIC1-W4AS1	10	3.2	640	31	10
	25	8	1600	168	21
	Test current limited for this CT to ~25 In,min*				
W5 [128-448 A], Construction Type 1, WIC1-W5AS1	10	3.2	1280	49	16
	Test current limited for this CT to ~10 In,min*				

Table 3: Required output power and voltage of test devices

*The CTs WIC1-W4AS1 and WIC1-W5AS1 of Construction Type 1 have a limited current range using the test sockets. For high currents it is recommended to switch to primary testing or to use the Construction Type 2 CTs: WIC1-CT4 and WIC1-CT5 do not have these restrictions regarding the test sockets.

10.6 Technical Data - WI1SZ4

Coil voltage: 24 V DC \pm 10%

- The WI1SZ4 can be set electrically.
- The WI1SZ4 can be reset mechanically.

Coil connection

Cable Color	Diameter	Function
black	0.25mm ²	Ground / Set

Maximum cable connection length: 1 m

See also the connection diagram, [↔“Coil connection WI1SZ4”](#).

10.7 Technical Data - WI1SZ5

Coil voltage: 24 V DC ± 10%

Contact Rating:

- 230 V AC / 3 A
- 230 V DC / 0.12 A
- 115 V DC / 0.2 A
- 24 V DC / 2 A
- The WI1SZ5 has two potential-free changeover contacts.
- The WI1SZ5 can be set and reset electrically.

The WI1SZ5 can be reset mechanically.

Coil connection

	Cable Color	Diameter	Function
Coil connection	brown	0.25mm ²	(-) Ground
	violet	0.25mm ²	(+) Set
	orange	0.25mm ²	(+) Reset
Changeover contact 1	black	0.5mm ²	NO contact
	blue	0.5mm ²	changeover contact
	red	0.5mm ²	NC contact
Changeover contact 2	white	0.5mm ²	NO contact
	yellow	0.5mm ²	changeover contact
	green	0.5mm ²	NC contact

“NO”: normally open. “NC”: normally closed.

Maximum cable connection length: 1 m

See also the connection diagram, ↪[“Coil connection WI1SZ5”](#).

11 Troubleshooting

11.1 In Case You Need to Contact Our Service-Team

Our service-team will need detailed information depending on the type of problem. If possible, we ask you kindly to have the following information ready; this will speed up our analysis of your problem.

We always need the following data:

- A detailed description of the problem.
- The serial number of the device, either from the type label, or from here: [Device Para / Version] »S/N«
- The build number of the firmware, either from the type label (if still up to date), or from here: [Device Para / Version] »Build«
- If the device has issued an error message our service-team needs to know the message text / type and the displayed "Value". (For example: Self-Supervision Message "SE1" with Value = 24307.)

The Self-Supervision Messages can be checked here: [Operation / Self-Supervision / Messages]

Depending on the type of the problem the following might also be useful for analysis:

- The settings file. (Transfer all settings into Smart view and save as a file in format *.WiPara.)

11.2 Self-Supervision Messages

The protection device supervises its normal operation by executing various self-supervision checks during runtime of the device.

Please check the self-supervision messages under [Operation / Self-Supervision / Messages].



Hint: You can assign the event, that a new error or warning message occurs, to a DiggiMEC LED. This way you can see immediately if something noteworthy has happened:

- [Device Para / DiggiMEC / LEDs] »LEDx assign.« = "Sys . New error/warning", see also [↪3.11.2 LED Configuration \(DiggiMEC\)](#).
- [Device Para / DiggiMEC / LEDs] »LEDx latching« = "With latching" (or = "Latch. w. Auto-Reset"), see also [↪3.11.3 Latching of the DiggiMEC LEDs](#).

Note: A device with a firmware labeled as "Prototype" (e. g. a specimen for trade fairs) has the following special behavior: If the Self-Supervision of the protection device has detected a (device-internal) error (as listed in [↪11.2.1 Self-Supervision - Error Messages](#)), the WIC1 System-ERROR-LED starts flashing red (in addition to the message that is recorded in the internal memory). The flashing can be reset via the direct command [Operation / Reset] »Sys . Rst. Err. LED«.

11.2.1 Self-Supervision – Error Messages

Description	Information	Corrective Action
SE 1 Abort	The WIC1 underwent an unscheduled restart.	Get in contact with our service-team. We recommend having the information listed in →11.1 In Case You Need to Contact Our Service-Team ready. In case of an error SE 1 , in particular the displayed “Value” is needed for further analysis. Depending on the type of problem, you will either be told how to fix the problem, or – if further device-internal data is needed – you will be supplied with a tool for error analysis.
SE 2...5 Problem w. resources	Critical level of WIC1-internal resources. It is not possible for the user to take any actions.	Get in contact with our service-team. You will be supplied with a tool for error analysis.
SE 18 Back-up Prot	The WIC1 has unexpectedly launched the mode →7.3 Backup Protection / Self-Supervision .	Get in contact with our service-team.
SE 19...23 DiggiMEC Problem w. resources	Critical level of DiggiMEC-internal resources. It is not possible for the user to take any actions.	Get in contact with our service-team.
SE 24 DiggiMEC Abort	The DiggiMEC underwent an unscheduled restart.	Get in contact with our service-team.
SE 25...28 SCADA Problem w. resources	Critical level of internal resources of the SCADA communication. All protection functions are not affected and are fully available. SCADA communication, however, is not functioning. It is not possible for the user to take any actions.	Get in contact with our service-team.
SE 29 SCADA Abort	SCADA communication crashed for some reason. All protection functions are not affected and are fully available. SCADA communication, however, is not functioning. It is not possible for the user to take any actions.	Get in contact with our service-team.
SE 30 SCADA Not Started	Starting SCADA communication was not possible due to a (hardware-related) error. All protection functions are not affected and are fully available. SCADA communication, however, is not functioning. It is not possible for the user to take any actions.	Get in contact with our service-team.
SE 31 Modbus Update Cycle	An internal error of the communication between co-processor and main CPU caused a failure of the internal update cycle (e. g. an error while transferring the measurement values to the co-processor).	All protection functions are not affected and are fully available, but the SCADA functionality has an internal (hardware or software) error. It is not possible for the user to take any actions. Get in contact with our service-team.
SE 32 Modbus TCP Stopped	The WIC1 has stopped TCP communication because there were 3 internal TCP	All protection functions are not affected and are fully available. TCP communication gets restarted by a normal device restart. However,

11 Troubleshooting

11.2.1 Self-Supervision - Error Messages

Description	Information	Corrective Action
	<i>communication errors within 5 minutes.</i>	depending on the particular situation and application it is likely that there is a permanent (hardware or software) problem. Therefore, it is recommended to get in contact with our service-team.

11.2.2 Self-Supervision - Warning Messages

Description	Information	Corrective Action
SW 1 <i>SSV Idx Overflow</i>	<i>There have been so many Self-Supervision messages (more than 65535) that the running number underwent an overflow.</i>	You might want to check all the listed messages for the potential reason of this excessive number of messages.
SW 2 <i>Run Mode</i>		<p>The displayed "Value" specifies whether the WIC1 is running in normal mode (Value = 1, full functionality) or in protection-only mode (Value = 2).</p> <p>After two device-internal errors within a short time, the WIC1 enters a protection-only mode. In this mode, all communication functionality (including connections to Smart view) is unavailable.</p> <p>(See also the signaling via LEDs, →"The »System« LED(s) - "Ready", "Error"").</p> <p>You can try to leave the protection-only mode (and re-enter normal mode) by a cold restart of the WIC1.</p>
SW 3 <i>V Superv.</i>	<i>A problem with the internal power supply of the WIC1 has been detected. This may affect the capability of the device to operate a trip coil and outputs.</i>	<p>A further safe operation of the WIC1 can be assumed only if you check the WIC1, proceeding as follows:</p> <p>WIC1-4 with external power:</p> <ul style="list-style-type: none"> • 1. ▷ Make sure the supplied voltage (and power) is sufficient. • 2. ▷ Restart the WIC1-4, executing the Direct Command [Service / General] »Sys . User Restart«. • 3. ▷ Wait for 5 minutes. • 4. ▷ Check whether this warning message has been issued again, and check that the Ready/System LED is lit in green color. <p>Self-powered WIC1:</p> <ul style="list-style-type: none"> • 1. ▷ Verify that there is no phase current flow (nor any supply via USB), so that the WIC1 is off. • 2. ▷ Feed in a phase current > 0.5 In,min in all 3 phases. • 3. ▷ Wait for 5 minutes. • 4. ▷ (Re-)connect a PC4 adapter or DiggiMEC. Check whether this warning message has been issued again, and check that the Ready/System LED is lit in green color. <p>In addition to the checks mentioned above (i. e. re-issue of the warning message, Ready/System LED), you should also check the outputs: Is it possible that the assigned signals rattle (e. g. a ground overcurrent pickup with a low pickup threshold)?</p> <p>It is also advisable to check the connection cable between WIC1 and PC4 adapter / DiggiMEC (if there is</p>

Description	Information	Corrective Action
		<p>one). (See also the related message in Chapter 3.13.)</p> <p>If the problem still persists after all these potential problems have been checked/ fixed get in contact with our service-team.</p>
SW 4 V Superv. FI	<i>A wrong configuration or usage of the output seems to have caused a problem with the internal power supply of the WIC1. This may affect the capability of the device to operate a trip coil and outputs.</i>	<p>For a WIC1-4: The output setting »Prot . Out. assign.« = „Prot . Syst. OK. & Ext.Suppl.“ must not be used in combination with a flag indicator, but only with special output relays. Change the configuration. Then perform a restart and all the checks described for warning SW 3.</p> <p>(More information about the use of the setting »Prot . Out. Mode« can be found in 3.10.1 Self-Supervision Contact for the WIC1-4.)</p> <p>For a WIC1-1, WIC1-2 or WIC1-3: Follow the description for warning message SW 3.</p>
SW 5 Modbus TX-stall	<i>There was an internal problem with Modbus communication. The communication channel has been reset and restarted.</i>	If the problem occurs often then get in contact with our service-team.
SW 6 V Superv. < 9V (TC/FI)	<i>During a pulse at the trip coil (TC) or flag indicator (FI) output a low device-internal voltage was detected.</i>	Get in contact with our service-team.
SW 7 V.TC Superv. (short-circuit?)	<i>During a pulse at the trip coil (TC) output a possible short-circuit was detected.</i>	Check the wiring at the trip coil (TC) output for any short-circuits.
SW 8 V.FI Superv. (short-circuit?)	<i>During a pulse at the flag indicator (FI) output a possible short-circuit was detected.</i>	Check the wiring at the flag indicator (FI) output for any short-circuits.
SW 9 ADC.FS superv.	<i>Information that the WIC1 may have detected a problem at the ADC inputs (current measurement).</i>	Get in contact with our service-team.

11.2.3 Self-Supervision - Information Messages

Description	Information	Corrective Action
SI 1 <i>Firmware Update</i>	<i>Information that a new device firmware has been installed on the WIC1. The displayed "Value" is the new Build number after the update.</i>	
SI 2 <i>Device restart</i>	<i>Information that the WIC1 has been restarted.</i>	The displayed "Value" shows the reason for the device restart. See the table in ↔7.1 Device Start (Reboot) . However, the restart reasons number 1 and 6 are intentionally omitted, i. e. get never listed as SI 2 messages.
SI 3 <i>Settings changed</i>	<i>Information that the settings (e.g. the protection parameters) have been modified.</i>	The message value is a counter value. Each change of the settings – independent of the number of changed parameters – increases this counter by 1. This is also true of settings that are made via DIP/HEX switches.
SI 4 <i>DiggiMEC Restart Reason</i>	<i>Information that the DiggiMEC has been restarted.</i>	The displayed "Value" shows the reason for the device restart. See the table in ↔7.1 Device Start (Reboot) . However, the restart reasons number 1 and 6 are intentionally omitted, i. e. get never listed as SI 4 messages.
SI 5 <i>DiggiMEC HMI Issue</i>	<i>Information about communication problems between WIC1 and the DiggiMEC HMI.</i>	The message value is a counter value. Each failure of data transfer between WIC1 and DiggiMEC increases this counter by 1. Note that the flag indicators / output relays are not affected.
SI 6 <i>Password changed</i>	<i>Information that the password has been changed by the user.</i>	The message value is the number of password changes that have been made within some time.
SI 7 <i>Invalid password</i>	<i>Information that a wrong password was entered.</i>	The message value is the number of wrong passwords that have been entered within some time.
SI 8 <i>SCADA Restart Reason</i>	<i>Information that the SCADA communication has been restarted.</i>	The displayed "Value" shows the reason for the restart. See the table in ↔7.1 Device Start (Reboot) . However, the restart reasons number 1 and 6 are intentionally omitted, i. e. get never listed as SI 8 messages.
SI 9 <i>Spike Detection (AABBCC)</i>	<i>Information that the WIC1 has detected a very high but short current peak (Indication CT saturation).</i>	No action required as the WIC1 is designed to operate properly in case of CT saturation.
SI 10 <i>LSCOEN Startup</i>	<i>Information that the WIC1 has detected and successfully fixed a MCU misconfiguration during device startup.</i>	No action required as the WIC1 has already resolved the issue.
SI 11 <i>LSCOEN Runtime</i>	<i>Information that the WIC1 has detected and successfully fixed</i>	No action required as the WIC1 has already resolved the issue.

11 Troubleshooting

11.2.3 Self-Supervision - Information Messages

Description	Information	Corrective Action
	<i>a MCU misconfiguration during device runtime.</i>	

11.3 Signals via LEDs (at WIC1 or DiggiMEC)

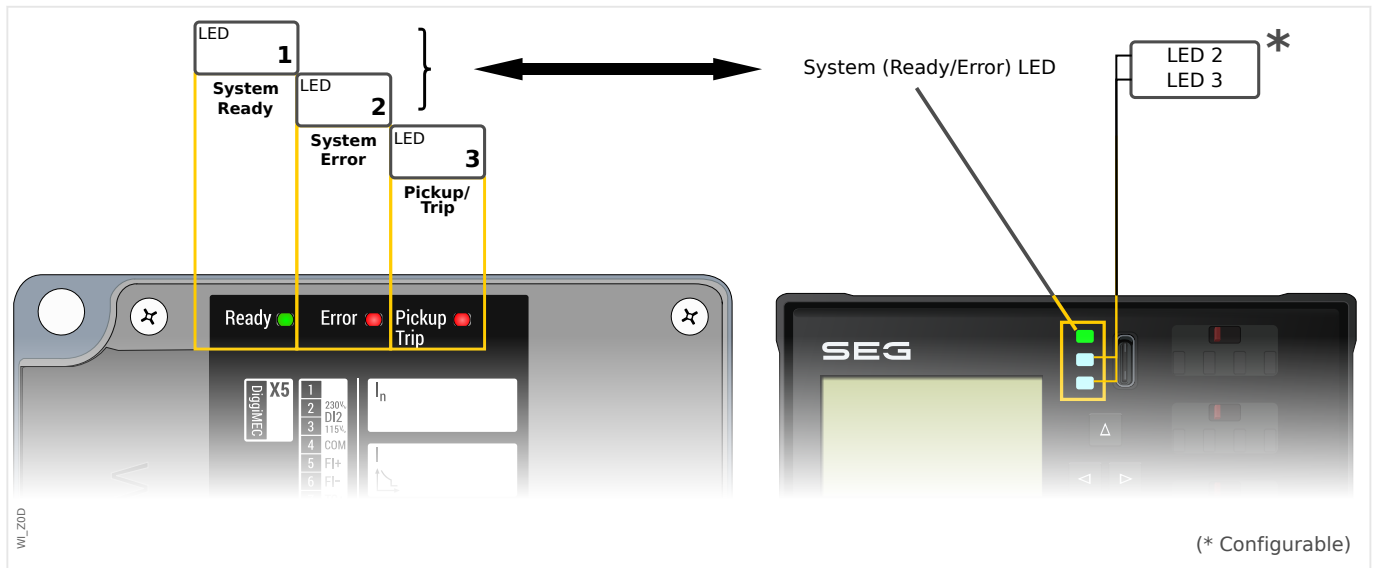

i The WIC1 features one green “READY” LED and a red “ERROR” LED. These two show the WIC1 overall health, so that they function as a “System LED”.

The DiggiMEC features three two-colored (red/green) LEDs, and the first LED corresponds to the “System LED”, as it (also) shows the WIC1 overall health.

System-/Ready-LED is Off (Not Illuminated)

Description	Information	Corrective Action
<p>The WIC1 Ready-LED is off (not illuminated), and (if a DiggiMEC is connected) the DiggiMEC System LED is also off.</p>	<p>The WIC1 is not ready (yet). Either it is still starting up, or there is no sufficient power supply (via the CTs).</p>	<p>If the WIC1 is still starting up wait for a while. The System LED is illuminated green only after all protection functions have become active and there is enough power for a trip pulse.</p> <p>Otherwise, please check the connected current inputs (and/or the supply voltage in case of a dual-powered variant). If it is OK, send the device back to SEG to be repaired.</p>
	<p>WIC1 and/or DiggiMEC have been started into the “Service Mode” (by pressing the »RESET« key during start-up).</p>	<p>This is not an error: This mode allows for resetting all parameters to the factory defaults, or you can install a firmware update. The DiggiMEC display should be working, and the displayed messages guide you through the available resetting or updating options.</p> <p>Afterwards, you can simply leave the “Service Mode” by another restart (of the DiggiMEC).</p>
<p>The DiggiMEC System LED is off (not illuminated), and the DiggiMEC display is also off.</p>	<p>The DiggiMEC is not supplied with electricity, neither from the WIC1, nor via the USB interface from a connected PC.</p>	<p>Check the connection to the WIC1. If the problem persists try to connect a PC to the DiggiMEC USB interface. (Note that the DiggiMEC is not usable without WIC1.)</p>
<p>The DiggiMEC System LED is off (not illuminated), but the DiggiMEC display is working.</p>	<p>The DiggiMEC is properly connected to the WIC1, but the</p>	<p>If the WIC1 is still starting up wait for a while. The System LED is illuminated green only after all protection functions</p>

Description	Information	Corrective Action
	<p><i>WIC1 reports that protection or tripping is not available.</i></p>	<p>have become active and there is enough power for a trip pulse.</p> <p>Otherwise, please check the connected current inputs (and/or the supply voltage in case of a dual-powered variant). Note that the supply via the DiggiMEC USB interface is sufficient for starting both WIC1 and DiggiMEC, but is not sufficient for enabling the WIC1 to issue a trip pulse. (The reason for this is that the pulse output needs to deliver 24 Volts, see →10.1.8.1 Impulse Output for the Tripping Coil, but USB supplies only 5 Volts.)</p> <p>Furthermore, check the WIC1 and its LEDs, check the System Recorder for recent entries. If it turns out that the WIC1 is defective send it back to SEG to be repaired.</p>

System-/Ready-LED is Lit Constantly Green

Description	Information	Corrective Action
<p><i>The WIC1 “Ready” LED is constantly green (and the same for the DiggiMEC System LED).</i></p>	<p><i>This is not a device error. The WIC1 is ready for operation and protects your electrical equipment, all protection functions have become active, and enough energy for a trip pulse has been stored. If you have the impression that the relay is not working correctly or you have any problems with setting the parameters, please check the next troubleshooting entries.</i></p>	<p>—</p>

System-/Error-LED is Flashing Red

Description	Information	Corrective Action
<p><i>The WIC1 “Error” LED is flashing red.</i></p>	<p><i>The WIC1 has probably done an automatic restart (due to previous device-internal errors) and entered the “Protection-Only” operating mode.</i></p>	<p>In this mode, only the protection and supervision functions have been started. (This might hopefully reduce the risk of another error.) Although the protection functionality is fully active it is recommended to check (and/or replace) the WIC1. Contact the SEG Support.</p>

Description	Information	Corrective Action
<p><i>The DiggiMEC System LED is flashing red ↔ green. The DiggiMEC display shows: “Level 1 - WIC1 stopped HMI support”</i></p>	<p><i>The WIC1 has probably done an automatic restart (due to previous device-internal errors) and entered the “Protection-Only” operating mode.</i></p>	<p>In this mode, only the protection and supervision functions have been started. (This might hopefully reduce the risk of another error.) Although the protection functionality is fully active it is recommended to check (and/or replace) the WIC1. Contact the SEG Support.</p>

System-/Error-LED is Lit Constantly Red

Description	Information	Corrective Action
The WIC1 "Error" LED is constantly red.	The (hardware-based) ↪7.3 Backup Protection / Self-Supervision mode is active, because the WIC1 could not start as normal due to a serious software or hardware error.	Try a restart, and/or contact SEG Support. Nevertheless, the WIC1 needs to be checked as soon as possible. Depending on the device variant the WIC1 still offers a backup protection in this mode.
The DiggiMEC System LED is constantly red. The DiggiMEC display shows: "Level 0 - No communication to WIC1"	This is only possible if the DiggiMEC is supplied with electricity via the USB interface from a connected PC, but there is no connection to the WIC1.	<p>Check the connection between DiggiMEC and WIC1.</p> <p>Check if the WIC1 is running in ↪7.3 Backup Protection / Self-Supervision mode. See also ↪7.4.</p> <p>Check whether the WIC1 is defective.</p> <p>If everything turns out to be o.k. contact the SEG Support.</p>

11.4 Problems with the Device

11.4.1 Hardware

Description	Information	Corrective Action
Supply via Powerbank is not possible.	The so-called powerbanks are constructed with respect to charging batteries, and many of them cannot be used as a permanent power supply.	<p>It is possible to supply the WIC1 with connected DiggiMEC by a PC, via the USB interface. This way it is possible to make settings without the supply via the CTs. (But keep in mind that the USB voltage of 5 Volt is not sufficient for the trip coil output or the flag indicators / output relays.)</p> <p>But this kind of supply via USB is not possible, if a powerbank is connected, instead of a PC. This is due to the design of a powerbank and cannot be solved by any means related to the DiggiMEC or WIC1!</p> <p>There are powerbank models with a key for power-on/wake-up/testing; these models output the USB voltage only after the key has been pressed.</p> <p>Independent of this, many powerbank models feature a device-internal automatic switch-off. As soon as the current flow drops below a particular value (typical 100 mA) the powerbank switches the voltage off. The reason is that the risk of overcharging a battery shall be minimized. But since DiggiMEC and WIC1 are designed for very low power consumption they use much less than 100 mA, and this fact makes such types of powerbanks unusable as a power supply of DiggiMEC und WIC1.</p>
Wrong measuring and tripping values.	Wrong wiring	Verify that the wiring of the contacts S1, S2 and of the test windings C, D is correct. Check the phase sequence and phase angle.

Description	Information	Corrective Action
	<i>Wiring of the test inputs / windings.</i>	The test windings must always be operated open (except during tests using the test inputs). Even wiring the test inputs to a test device can have a negative effect on the measurement of the primary current.
	<i>Use of the test inputs / windings.</i>	During use of the test inputs, there must be no primary current flow as this has negative influence on the current measurement. Please note that the tolerances only apply for primary current measurement as the accuracy using the test inputs may be lower.
	<i>Grounding of a winding terminal of the measuring winding.</i>	No winding terminal of the measuring winding must be grounded! Grounding is done internally and connected with terminal "PE", see ↔3.1.2 Grounding .
Low-energy tripping coil does not trip.	<i>The coil polarized with permanent magnet has been connected to TC+ und TC- with the wrong polarity.</i>	Check the wiring.
Failure of a binary output (DiggiMEC).	<i>The physical status does not match the reported state, as it is being shown via Smart view.</i>	Check the following issues: <ul style="list-style-type: none"> • Is the binary output in latched state? (»BOX latching« = „With latching“)? • Try to reset the output, e. g. via the Direct Command [Operation / Reset] »Rst. LEDs, Fls«. • Check the wiring. • See also the entry Binary outputs do not react. • If all these checks do not yield any results, send the device back to the manufacturer.
Failure of a binary input (WIC1).	<i>The physical status does not match the reported state, as it is being shown via Smart view.</i>	Check the following issues: <ul style="list-style-type: none"> • Check the typecode of the WIC1 - Does this device variant feature configurable Digital Inputs? • Is the voltage level set correctly? Check the setting at [Device Para / WIC1 / Digital Inputs] »Nom voltage«. • Is the voltage level of the digital input (i. e. the signal level) correct? • Check the wiring. • If all these checks do not yield any results, send the device back to the manufacturer.
No system time is shown via Smart view.	<i>This is not an error, as the WIC1 does not feature a real-time clock.</i>	All timestamps, as shown e. g. in the Fault Recorder, refer to the device uptime, i. e. this is the time since the last reboot.

11.4.2 Operation of the Device

Description	Information	Corrective Action
<p>The binary outputs or LEDs are in unexpected state.</p>	<p>A binary output or an LED has been reconfigured from latched to unlatched.</p>	<p>Try to reset the WIC1, e. g. via the Direct Command [Operation / Reset] »Rst. LEDs, Fls«.</p> <p>Independent of this, note that the set value of »t-Off Delay« has to elapse before the binary outputs / LEDs will change their state.</p> <p>Moreover, note that a latched state even »survives« a restart of the device.</p>
<p>Smart view is set to the wrong language (e. g. English).</p>	<p>You have installed Smart view with English language. Now you want to switch to a different language.</p>	<p>Select [Settings / Language] within Smart view and select your desired language. A window will pop up. This informs you that the language will get activated after a restart of Smart view. Accept this information, close and restart Smart view.</p>
<p>The display of the DiggiMEC shows the message:</p> <p>Panel not available Update DiggiMEC! (see Manual WIC1) WIC1 accessible via USB/PC</p>	<p>The DiggiMEC does not work as an HMI currently and can only be used for connection with a PC via Smart view.</p>	<p>Please make sure DiggiMEC and WIC1 have compatible firmware versions. For example, a WIC1 with DM version 2.3 requires a DiggiMEC with DM version 2.3.</p> <p>You can still connect a Windows-PC (with an installed Smart view) to the DiggiMEC, so that you can operate the WIC1 as usual, via Smart view. But the DiggiMEC will be re-enabled to show values and settings only by bringing DiggiMEC and WIC1 to a matching firmware version.</p>

11.4.3 Parameter Settings

Description	Information	Corrective Action
<p>All settings are locked against changes in Smart view.</p>	<p><i>This is probably not an error, but due to the parameter setting [Device planning / WIC1 + DiggiMEC] »Prot . Settings valid« = "Switches".</i></p>	<p>Set »Prot . Settings valid« = "Software" to enable a configuration via DiggiMEC and/or Smart view.</p> <p>(Be aware, however, that DIP/Hex switches are ignored by then. See also ↪Chapter 2.2.2.)</p>
<p>Settings via DIP/HEX switches are not possible anymore.</p>	<p><i>This is probably not an error, but due to the parameter setting [Device planning / WIC1 + DiggiMEC] »Prot . Settings valid« = "Software".</i></p>	<p>The DIP/HEX switches are taken into account again only after a reset to factory defaults. This is achieved by the direct command [Service / General] »Factory Reset«.</p> <p>(See also ↪2.12 Reset to Factory Defaults.)</p>

11.4.4 Protection and Control

Description	Information	Corrective Action
Problem with current measurement.	<i>The measured values of current show a big fluctuation.</i>	Adjust [Field Para / General Settings] »f« to the connected grid frequency (50 Hz or 60 Hz).
Binary outputs do not react.	<i>The contacts of the binary outputs do not open or close. This can be checked by simulating a fault and checking the binary output contacts with measurement equipment.</i>	<p>Check the following issues:</p> <ul style="list-style-type: none"> • Has the DiggiMEC been correctly set within the WIC1 settings? (Check menu branches [Device planning / WIC1 + DiggiMEC] and [Device Para / DiggiMEC].) • Acknowledge the binary outputs, if applicable. • Is the status of the binary output forced to a dedicated value? (The binary output can be overwritten for commissioning purpose, see menu branch [Service / Test - Prot inhib].) • Is the required protection function active? • Is overall protection active? • Are the field parameters set correctly (CT ratio etc.)? • Are the protection parameters set correctly (trip value, trip time)? • Is the assigned protection function blocked? • Is the wiring correct?

11.4.5 Communication

Description	Information	Corrective Action
<p>The PC4 adapter / DiggiMEC is correctly connected to a PC, but the USB COM port is not visible on the PC.</p>	<p>It is not possible to connect Smart view to the PC4 adapter / DiggiMEC via USB. The corresponding USB port (e. g. COM 5) is not visible in the application.</p> <p>Only DiggiMEC: The USB port (e. g. COM 5) is not visible in Smart view.</p>	<p>Check the following issues:</p> <ul style="list-style-type: none"> • <i>Smart view</i>: Try a newer version of <i>Smart view</i>. See http://docs.segelectronics.de/smart_view. • Plug off the USB cable from the protective device and plug it in again. After 10 seconds try again to connect <i>Smart view</i> to the relay. • Restart your PC. • The PC4 adapter should be shown as "USB Serial Port (COM n)" • The DiggiMEC should be shown as "WI Line DiggiMEC USB (COM n)" <p>Open the <i>Device Manager</i> of the Windows PC, and check the entries below "Connections (COM & LPT)".</p> <ul style="list-style-type: none"> • If the DiggiMEC is listed as a generic "Serial USB Device (COM n)" [Windows 10], or as an "Unknown Device" [Windows 7] then the USB driver has not been properly installed during the installation of <i>Smart view</i>. <p>(Re-)Install the USB driver that comes with the <i>Smart view</i> setup. (Driver installations require Administrator privileges.)</p> <p>A PC-DiggiMEC-WIC1 connection must be listed as "WI Line DiggiMEC USB (COM n)" in the <i>Device Manager</i>.</p>
<p>The USB COM port is visible, but no connection is possible.</p>	<p>It is not possible to communicate with Smart view to the WIC1 (via PC4 adapter / DiggiMEC and) via USB. The corresponding USB port (e. g. COM 5) is available and has been selected correctly.</p>	<p>Check the following issues:</p> <ul style="list-style-type: none"> • Are the PC4 adapter / DiggiMEC and the WIC1 started up completely and connected with each other)? • Is the USB port of the PC still occupied by another application (or program)? Close those applications. • Have special applications for communication analysis been installed on the PC? (In very rare cases it has been observed that some so-called "sniffers" – applications that monitor or log the serial communication messages – interfere with or even prevent the USB connection with the protective device.)
<p>Smart view cannot connect to the PC4 adapter / DiggiMEC / WIC1 although this has been possible before using the same PC.</p>	<p>A connection between Smart view and PC4 adapter / DiggiMEC / WIC1 has been possible before using the same PC. Now it is no longer possible to connect to the device.</p>	<p>Check the following issues:</p> <ul style="list-style-type: none"> • Are the connection settings of <i>Smart view</i> correct? (Check at menu [Settings / Device Connection...].) • Check the wiring between PC and device.

Description	Information	Corrective Action
		<ul style="list-style-type: none"> • Wait for 15 minutes and then try again to connect to the device. • Restart your PC and then try again to connect to the device.
<p>No communication (data transfer) with Smart view possible, even though a connection has been established.</p>	<p>Required TCP/IP ports are not available.</p>	<p>Make sure that all TCP/IP ports in the range 52152 ... 52164 are available. They must neither be blocked by a firewall nor be used by any other software.</p>
<p>Neither SCADA communication nor a DiggiMEC / Smart view connection is available.</p>	<p>Some device-internal error has caused several automatic restarts, and now the WIC1 is in operating mode "Protection Only" or in ↔7.3 Backup Protection / Self-Supervision mode.</p>	<p>There is no communication available in these two operating modes. (see also ↔"The »System« LED(s) - "Ready", "Error""))</p> <p>In "Protection Only" mode all protection functions (including DiggiMEC flag indicators / output relays) are fully active. In ↔7.3 Backup Protection / Self-Supervision mode it depends on the device variant if there is a backup protection.</p> <p>It is recommended to check (and/or replace) the WIC1.</p>
<p>No SCADA communication via TCP/IP possible.</p>	<p>The TCP/IP settings including subnet mask is not configured appropriately. Communication is not possible due to an unexpected amount of requests (network storm).</p>	<p>It is recommended to check the TCP/IP settings and test the network communication in an isolated network (e.g. using ping). Check communication problems in a non-isolated network for a possible network storm.</p>

12 Appendix

12.1 Appendix - Settings via DIP / HEX Switches

- The device variants WIC1-2, WIC1-3 are fitted with DIP/HEX switches for configuration. In this case, there is no need for a PC4 adapter or DiggiMEC for configuration.
 - WIC1-2: See the overview in [↔12.1.1 Settings via DIP / HEX Switches \(WIC1-2, WIC1-3\)](#).
- The configuration via Smart view (PC) / DiggiMEC, however, offer extended setting ranges and access to additional protection functions. (The device variants WIC1-1, WIC1-4 can only be configured via Smart view (PC) / DiggiMEC.)

The general steps are as follows:

⚙	
1.	▷ Check your object to be protected. (For a WIC1, this is usually a transformer.) From this, find out the primary nominal current I_n .
2.	▷ Select a WIC1-compatible CT. The current range of the CT must fit to the primary nominal current I_n .
3.	▷ So, let us say the current range of the CT is $I_{n,min} \dots I_{n,max}$. The WIC1 uses a setting $\gg I_n,relative \ll$, that defines the primary nominal current as a multiplication factor of the lower range limit $I_{n,min}$: $I_n = \gg I_n,relative \ll \cdot I_{n,min}$ Example: Your nominal current is 96 A, you select W4 as the CT. The current range of the W4 CT is 64 ... 224 A . This means: $I_{n,min} = 64$ A, and your primary nominal current is $96 \text{ A} = 1.5 \cdot 64 \text{ A}$. So, for this example you have the setting value $\gg I_n,relative \ll = 1.5$.
▶	Lookup the DIP/HEX switch positions for $\gg I_n,relative \ll = 1.5$ in the overview diagram, ↔12.1.1 Settings via DIP / HEX Switches (WIC1-2, WIC1-3) . For more details, see ↔3.3 Current Transformers (CTs) , especially ↔3.3.1.1 Current Ranges of the WIC1-Wx-CTs . The tables in ↔12.1.2 Setting of the Rated CT current I_n might also be helpful.
4.	▷ The setting $\gg I_n,relative \ll$ is crucial, all other protection settings depend on this. After this, the protection thresholds and delay settings can be made straight-forward according to the overview diagram, ↔12.1.1 Settings via DIP / HEX Switches (WIC1-2, WIC1-3) .

12.1.1 Settings via DIP / HEX Switches (WIC1-2, WIC1-3)

For the WIC1-2 and WIC1-3, the following settings can be made directly at the device, using the built-in switches:

- Setting of the Rated CT current, see [↔12.1.2 Setting of the Rated CT current In](#).
- Setting of Characteristic, Pickup Current and Tripping Time / Characteristic Time of Phase Overcurrent Protection, stages I> and I>>, see [↔5.3.2 Phase Overcurrent Protection - Settings](#).
- Setting of the Characteristic, Pickup Current and Tripping Time / Characteristic Time of the Earth (Ground) Overcurrent Protection, stage IG>, see [↔5.5.2 Earth \(Ground\) Overcurrent Protection - Settings](#).
- Setting of the harmonics ratio and maximum current for the Inrush Protection, see [↔5.4 IH2 - Inrush Blocking](#).
- Setting of the Pickup Current and Supervision Mode for the Peak Overcurrent Protection, see [↔5.9 Ipeak> - Peak Overcurrent Protection](#).

For the [standard variant](#), the upper four DIP switch blocks respectively the upper 8 HEX switches are compatible with the first generation WIC11 (except for the additional overcurrent characteristics).

Although the enhanced protection functionality has made us increase the number of switches with this second WIC1 version, however, the total number of switches is obviously limited by the size of the housing. Therefore some settings cannot be set via a switch. These settings can be set only via Smart view (PC) / DiggiMEC.

Please note that the DIP / HEX assignment depends on the [Order Code](#) of the WIC1!

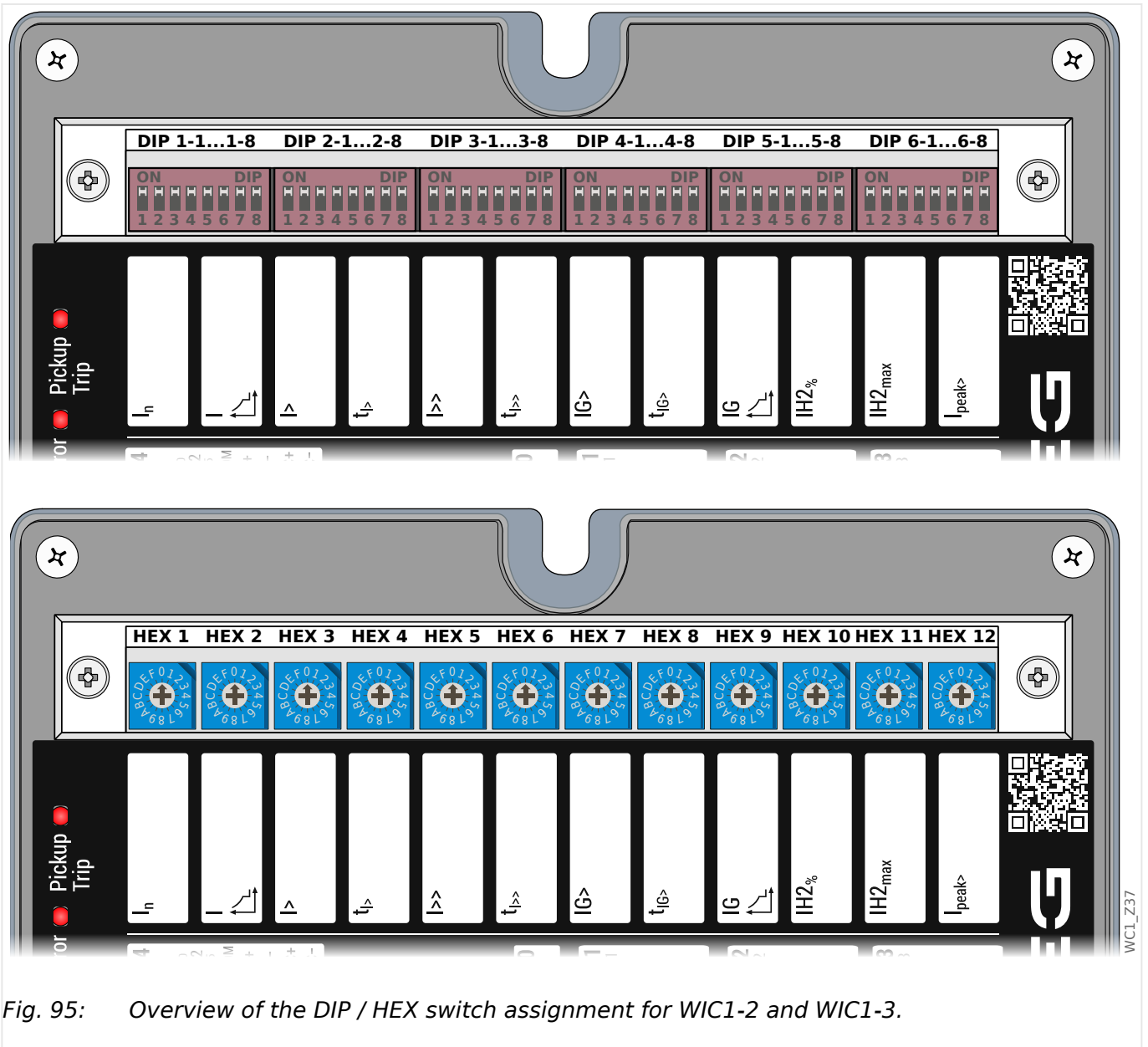
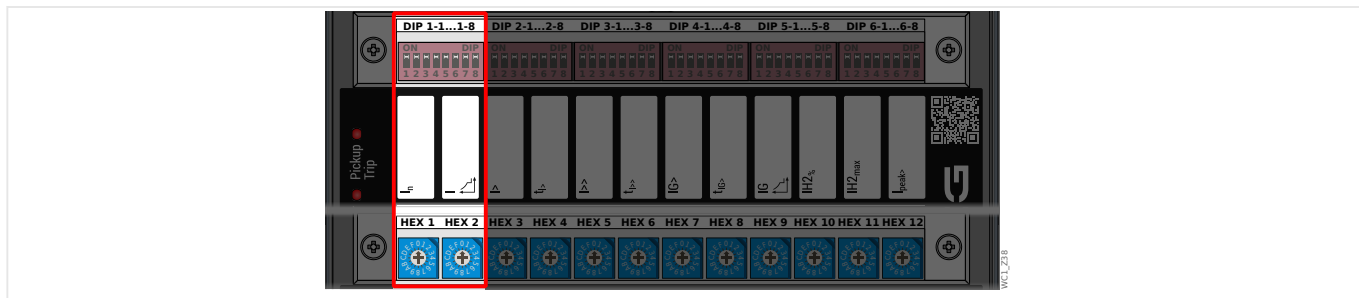

Fig. 95: Overview of the DIP / HEX switch assignment for WIC1-2 and WIC1-3.

12.1.1 Settings via DIP / HEX Switches (WIC1-2, WIC1-3)



WIC1-2Sxxxxx	WIC1-2Dxxxxx	HEX	DIP			
»CT . In,relative« [ln,min]	-	1	1-1	1-2	1-3	1-4
1.0	-	0	0	0	0	0
1.125	-	1	1	0	0	0
1.25	-	2	0	1	0	0
1.375	-	3	1	1	0	0
1.5	-	4	0	0	1	0
1.625	-	5	1	0	1	0
1.75	-	6	0	1	1	0
1.875	-	7	1	1	1	0
2.0	-	8	0	0	0	1
2.125	-	9	1	0	0	1
2.25	-	A	0	1	0	1
2.5	-	B	1	1	0	1
2.75	-	C	0	0	1	1
3.0	-	D	1	0	1	1
3.25	-	E	0	1	1	1
3.5	-	F	1	1	1	1

WIC1-2Sxxxxx	WIC1-2Dxxxxx	HEX	DIP			
»I> . Char«	-	2	1-5	1-6	1-7	1-8
DEFT	-	0	0	0	0	0
IEC NINV	-	1	1	0	0	0
IEC VINV	-	2	0	1	0	0
IEC EINV	-	3	1	1	0	0
IEC LINV	-	4	0	0	1	0
RINV	-	5	1	0	1	0
HV Fuse	-	6	0	1	1	0
FR Fuse	-	7	1	1	1	0
IEEE MINV	-	8	0	0	0	1
IEEE VINV	-	9	1	0	0	1
IEEE EINV	-	A	0	1	0	1
EF Curve	-	B	1	1	0	1
-	-	C	0	0	1	1
-	-	D	1	0	1	1
-	-	E	0	1	1	1
-	-	F	1	1	1	1

12 Appendix

12.1.1 Settings via DIP / HEX Switches (WIC1-2, WIC1-3)

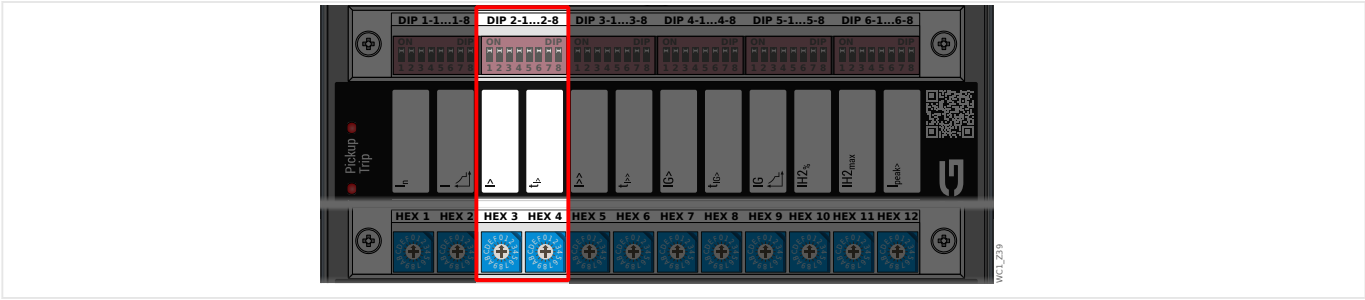

WIC1-xSxxxxxxx	WIC1-xDxxxxxxx	HEX	DIP			
»I> . I« [In]	»I> . I« [In]	3	2-1	2-2	2-3	2-4
0.9	0.1	0	0	0	0	0
0.95	0.15	1	1	0	0	0
1.0	0.2	2	0	1	0	0
1.05	0.25	3	1	1	0	0
1.1	0.3	4	0	0	1	0
1.15	0.35	5	1	0	1	0
1.2	0.4	6	0	1	1	0
1.3	0.45	7	1	1	1	0
1.4	0.5	8	0	0	0	1
1.5	0.55	9	1	0	0	1
1.6	0.6	A	0	1	0	1
1.8	0.7	B	1	1	0	1
2.0	0.8	C	0	0	1	1
2.25	0.9	D	1	0	1	1
2.5	1.0	E	0	1	1	1
»I> . Function« = "Inactive"		F	1	1	1	1

WIC1-xSxxxxxxx	WIC1-xDxxxxxxx	WIC1-xSxxxxxxx	WIC1-xDxxxxxxx	HEX	DIP			
If: »I> . Char« = "DEFT"		Else:		4	2-5	2-6	2-7	2-8
»I> . t« [s]	»I> . t« [s]	»I> . tChar«						
0.04	0.0	0.05		0	0	0	0	0
0.3	0.3	0.1		1	1	0	0	0
0.6	0.6	0.2		2	0	1	0	0
1.0	1.0	0.3		3	1	1	0	0
2.0	2.0	0.4		4	0	0	1	0
3.0	3.0	0.5		5	1	0	1	0
4.0	4.0	0.6		6	0	1	1	0
6.0	6.0	0.8		7	1	1	1	0
8.0	8.0	1.0		8	0	0	0	1
10.0	10.0	2.0		9	1	0	0	1
15.0	15.0	3.0		A	0	1	0	1
30.0	30.0	4.0		B	1	1	0	1
60.0	60.0	5.0		C	0	0	1	1
120.0	120.0	6.0		D	1	0	1	1
210.0	210.0	8.0		E	0	1	1	1
300.0	300.0	10.0		F	1	1	1	1

12.1.1 Settings via DIP / HEX Switches (WIC1-2, WIC1-3)

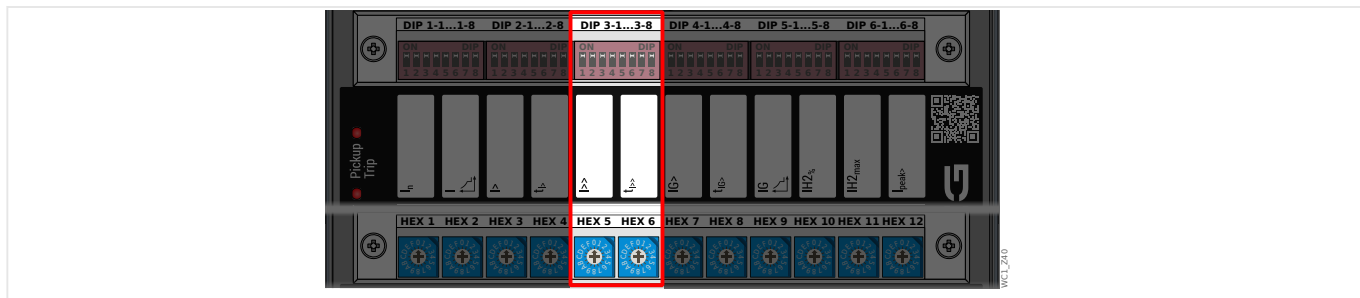

WIC1-xSxxxxxxxx	WIC1-xDxxxxxxxx	HEX	DIP			
»I>> . I« [In]		5	3-1	3-2	3-3	3-4
1.0		0	0	0	0	0
2.0		1	1	0	0	0
3.0		2	0	1	0	0
4.0		3	1	1	0	0
5.0		4	0	0	1	0
6.0		5	1	0	1	0
7.0		6	0	1	1	0
8.0		7	1	1	1	0
9.0		8	0	0	0	1
10.0		9	1	0	0	1
12.0		A	0	1	0	1
14.0		B	1	1	0	1
16.0		C	0	0	1	1
18.0		D	1	0	1	1
20.0		E	0	1	1	1
»I>> . Function« = "Inactive"		F	1	1	1	1

WIC1-xSxxxxxxxx	WIC1-xDxxxxxxxx	HEX	DIP			
»I>> . t« [In]	»I>> . t« [In]	6	3-5	3-6	3-7	3-8
0.04	0.0	0	0	0	0	0
0.07	0.07	1	1	0	0	0
0.1	0.1	2	0	1	0	0
0.15	0.15	3	1	1	0	0
0.2	0.2	4	0	0	1	0
0.25	0.25	5	1	0	1	0
0.3	0.3	6	0	1	1	0
0.4	0.4	7	1	1	1	0
0.6	0.6	8	0	0	0	1
0.8	0.8	9	1	0	0	1
1.0	1.0	A	0	1	0	1
1.4	1.4	B	1	1	0	1
1.8	1.8	C	0	0	1	1
2.2	2.2	D	1	0	1	1
2.6	2.6	E	0	1	1	1
3.0	3.0	F	1	1	1	1

12 Appendix

12.1.1 Settings via DIP / HEX Switches (WIC1-2, WIC1-3)

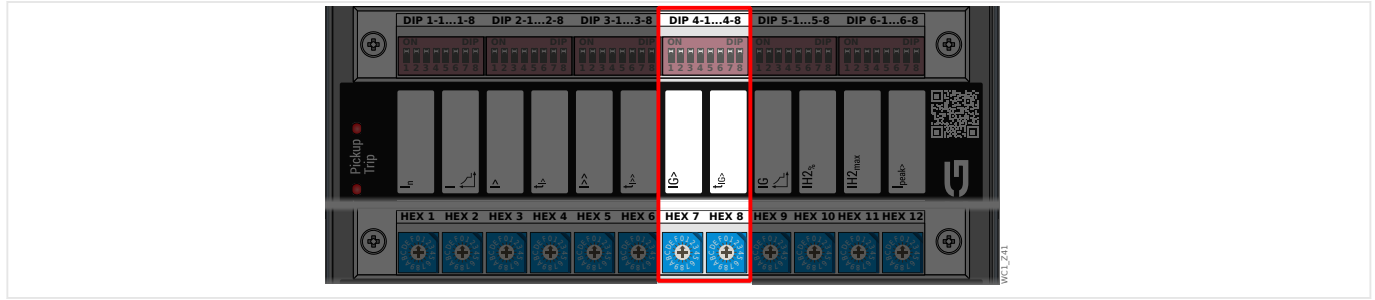

WIC1-xSxxxxxxxx	WIC1-xDxxxxxxxx	HEX	DIP			
»IG> . IG« [ln]	»IG> . IG« [ln]	7	4-1	4-2	4-3	4-4
0.2	0.02	0	0	0	0	0
0.3	0.03	1	1	0	0	0
0.4	0.04	2	0	1	0	0
0.5	0.05	3	1	1	0	0
0.6	0.1	4	0	0	1	0
0.7	0.15	5	1	0	1	0
0.8	0.2	6	0	1	1	0
0.9	0.25	7	1	1	1	0
1.0	0.3	8	0	0	0	1
1.2	0.4	9	1	0	0	1
1.4	0.5	A	0	1	0	1
1.6	0.6	B	1	1	0	1
1.8	0.7	C	0	0	1	1
2.0	0.8	D	1	0	1	1
2.5	1.0	E	0	1	1	1
»IG> . Function« = "Inactive"		F	1	1	1	1

WIC1-xSxxxxxxxx	WIC1-xDxxxxxxxx	WIC1-xSxxxxxxxx	WIC1-xDxxxxxxxx	HEX	DIP			
If: »IG> . Char« = "DEFT"		Else:		8	4-5	4-6	4-7	4-8
»IG> . t« [s]		»IG> . tChar«						
0.1		0.05		0	0	0	0	0
0.2		0.1		1	1	0	0	0
0.4		0.2		2	0	1	0	0
0.6		0.3		3	1	1	0	0
0.8		0.4		4	0	0	1	0
1.0		0.5		5	1	0	1	0
1.5		0.6		6	0	1	1	0
2.0		0.8		7	1	1	1	0
2.5		1.0		8	0	0	0	1
3.0		2.0		9	1	0	0	1
3.5		3.0		A	0	1	0	1
4.0		4.0		B	1	1	0	1
6.0		5.0		C	0	0	1	1
8.0		6.0		D	1	0	1	1
10.0		8.0		E	0	1	1	1
20.0		10.0		F	1	1	1	1

12.1.1 Settings via DIP / HEX Switches (WIC1-2, WIC1-3)

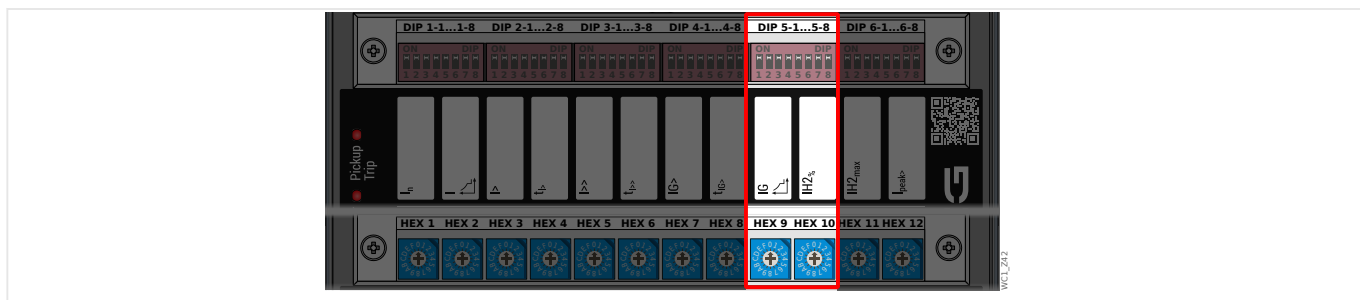

WIC1-2Sxxxxx	WIC1-2Dxxxxx	HEX	DIP			
»IG> . Char«		9	5-1	5-2	5-3	5-4
DEFT		0	0	0	0	0
IEC NINV		1	1	0	0	0
IEC VINV		2	0	1	0	0
IEC EINV		3	1	1	0	0
IEC LINV		4	0	0	1	0
RINV		5	1	0	1	0
HV Fuse		6	0	1	1	0
FR Fuse		7	1	1	1	0
IEEE MINV		8	0	0	0	1
IEEE VINV		9	1	0	0	1
IEEE EINV		A	0	1	0	1
EF Curve		B	1	1	0	1
RXIDG		C	0	0	1	1
-		D	1	0	1	1
-		E	0	1	1	1
-		F	1	1	1	1

WIC1-xSxxxxxxxxx	WIC1-xDxxxxxxxxx	HEX	DIP			
»IH2 . IH2 / IH1« [%]		10	5-5	5-6	5-7	5-8
15.0		0	0	0	0	0
16.0		1	1	0	0	0
17.0		2	0	1	0	0
18.0		3	1	1	0	0
20.0		4	0	0	1	0
22.0		5	1	0	1	0
24.0		6	0	1	1	0
26.0		7	1	1	1	0
28.0		8	0	0	0	1
30.0		9	1	0	0	1
32.0		A	0	1	0	1
34.0		B	1	1	0	1
36.0		C	0	0	1	1
38.0		D	1	0	1	1
40.0		E	0	1	1	1
»IH2 . Function« = "Inactive"		F	1	1	1	1

12 Appendix

12.1.1 Settings via DIP / HEX Switches (WIC1-2, WIC1-3)

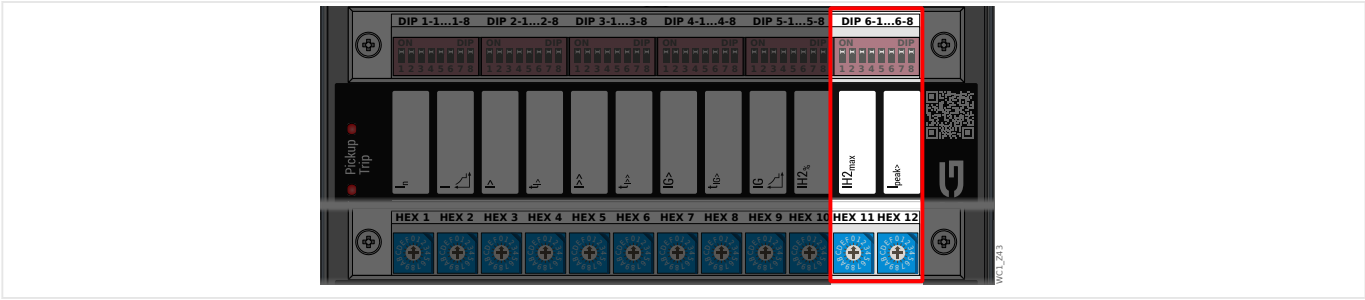

WIC1-xSxxxxxxxx	WIC1-xDxxxxxxxx	HEX	DIP			
»IH2 . I _{max} « [In]		11	6-1	6-2	6-3	6-4
2.0		0	0	0	0	0
3.0		1	1	0	0	0
4.0		2	0	1	0	0
5.0		3	1	1	0	0
6.0		4	0	0	1	0
7.0		5	1	0	1	0
8.0		6	0	1	1	0
9.0		7	1	1	1	0
10.0		8	0	0	0	1
11.0		9	1	0	0	1
12.0		A	0	1	0	1
13.0		B	1	1	0	1
14.0		C	0	0	1	1
15.0		D	1	0	1	1
18.0		E	0	1	1	1
20.0		F	1	1	1	1

WIC1-xSxxxxxxxx	WIC1-xDxxxxxxxx	WIC1-xSxxxxxxxx	WIC1-xDxxxxxxxx	HEX	DIP			
»SOTF . Mode« = "use" »I _{peak} > . Definition« = "Alarm"		»SOTF . Mode« = "Do not use" »I _{peak} > . Definition« = "Trip"		12	6-5	6-6	6-7	6-8
»I _{peak} > . I« [In]		»I _{peak} > . I« [In]						
4.0		-		0	0	0	0	0
6.0		-		1	1	0	0	0
8.0		-		2	0	1	0	0
10.0		-		3	1	1	0	0
12.0		-		4	0	0	1	0
14.0		-		5	1	0	1	0
16.0		-		6	0	1	1	0
20.0		-		7	1	1	1	0
-		4.0		8	0	0	0	1
-		6.0		9	1	0	0	1
-		8.0		A	0	1	0	1
-		10.0		B	1	1	0	1
-		12.0		C	0	0	1	1
-		15.0		D	1	0	1	1
-		20.0		E	0	1	1	1
-		»I _{peak} > . Function« = "Inactive"		F	1	1	1	1

12.1.2 Setting of the Rated CT current In

WIC1-2: DIP switch block 1, switches 1...4

WIC1-3: HEX switch 1

Please note that the DIP / HEX assignment depends on the [Order Code](#) of the WIC1. This section is valid for WIC1-Wx CT compatible Order Codes only. More information on DIP / HEX assignment can be found under [↔2 WIC1 - Introduction, Operation](#).

The primary values in Ampere in the following table depend on the WIC1-Wx CT type. (See also the considerations in [↔3.3.1 WIC1-Wx CTs \(Primary Measurement\)](#).)

(CT types: See [↔2.6.1.3 Order Form of the WIC1-Compatible Current Transformers](#))

Related setting via Smart view (PC) or DiggiMEC:

- [Field Para / CT] »CT . In,relative«, see also [↔5.2 Field Parameters](#).

This is a relative rated current in units of [In,min], i. e. a rated current value without the CT type dependency.

The rated current In can be set for WIC1-compatible CTs within the range $In = In,min \dots In,max = 1.0 \dots 3.5 In,min$.

- In,min — lower rated current limit
- In,max — upper rated current limit

»CT . In,relative«	W2 WE2	W3	W4	W5	W6	HEX	DIP			
[In,min]	[A]	[A]	[A]	[A]	[A]	1	1-1	1-2	1-3	1-4
1.0	16	32	64	128	256	0	0	0	0	0
1.125	18	36	72	144	288	1	1	0	0	0
1.25	20	40	80	160	320	2	0	1	0	0
1.375	22	44	88	176	352	3	1	1	0	0
1.5	24	48	96	192	384	4	0	0	1	0
1.625	26	52	104	208	416	5	1	0	1	0
1.75	28	56	112	224	448	6	0	1	1	0
1.875	30	60	120	240	480	7	1	1	1	0
2.0	32	64	128	256	512	8	0	0	0	1
2.125	34	68	136	272	544	9	1	0	0	1
2.25	36	72	144	288	576	A	0	1	0	1
2.5	40	80	160	320	640	B	1	1	0	1
2.75	44	88	176	352	704	C	0	0	1	1
3.0	48	96	192	384	768	D	1	0	1	1
3.25	52	104	208	416	832	E	0	1	1	1
3.5	56	112	224	448	896	F	1	1	1	1

12.2 Appendix - Time Overcurrent Characteristics

12.2.1 Characteristics ($I>$, $I>>$, $I>>>$)

For each phase overcurrent stage, the following characteristics are available:

- **DEFT** - *Definite Time-Overcurrent*
- **Inverse-Time Overcurrent Curves according to IEC 60255-151:**
 - **NINV** - *IEC Normal Inverse* (IEC 60255-151)
 - **VINV** - *IEC Very Inverse* (IEC 60255-151)
 - **LINV** - *IEC Long Time Inverse* (IEC 60255-151)
 - **EINV** - *IEC Extremely Inverse* (IEC 60255-151)
- **RINV** - *R Inverse*
- **HV Fuse** Fuse Characteristic of an HV Fuse
- **FR Fuse** Fuse Characteristic of a Full Range Fuse
- **Curves Defined in IEEE C37.112:**
 - **MINV** - *IEEE Moderately Inverse* (IEEE C37.112)
 - **VINV** - *IEEE Very Inverse* (IEEE C37.112)
 - **EINV** - *IEEE Extremely Inverse* (IEEE C37.112)
- **EF Curve** "EF" Curve

Explanation for All Characteristics ($I>$, $I>>$, $I>>>$)

(Remark: All settings are given for protection stage » $I>$ «. » $I>>$ « and » $I>>>$ « have the same settings with corresponding menu branches.)

- **I**: Fault current
- **$I>$ = $I_{>}$** : Pickup value for the Phase Overcurrent stage. If the pickup value is exceeded, the stage starts to time out to trip.
Setting: [Protection Para / $I>$] » I «
- Trip delay t for $I > I_{>}$:
 - for »Char« = "DEFT": settable via [Protection Para / $I>$] » t «.
 - for all other characteristics: calculated based on the selected curve.
- Reset mode for $I < I_{>}$, settable via »Reset Mode«, available options:
 - With option »Reset Mode« = "instantaneous": Instantaneous reset: when the current drops below the pickup setting, the TOC time resets to zero within 2 cycles.
 - With option »Reset Mode« = "definite time": The reset delay is settable at » t_{Reset} «.

- With option »Reset Mode« = “inverse time” (only available for IEC and ANSI/IEEE curves): The reset delay is calculated based on the selected characteristics.
- tChar (for all characteristics except “DEFT”):
 - Time multiplier/tripping characteristic factor. The setting range depends on the selected tripping curve.
 - Setting via [Protection Para / $I>$] »tChar«

For all inverse-time characteristics (i. e. all curves except the DEFT), there are two minimum trip delays, and independent of the selected characteristic will the actual trip delay never be smaller than any of these two minimum delays.

- » $I>$. tMinimum« is a minimum delay settable by the user. So, this is simply a timer that is triggered independent of the inverse-time curve and that has to elapse before the protection stage trips. If it is set to 0 seconds it is deactivated. (See also →5.3.2.1 Phase Overcurrent Protection – Settings via Smart view (PC) or DigiMEC.)
- Another minimum delay, $t_{Dyn.Lim.}$, results from a calculated “knee-point” of the characteristic. This means it is dependent on a particular current value on the curve, $I_{Dyn.Lim.}$. The effective trip delay does never fall below $t_{Dyn.Lim.}$, independent of the actual value of I .
 - $I_{Dyn.Lim.}$ is defined as the smallest value out of $20 \cdot I_n$ and $20 \cdot I>$ (EF Curve: $30 \cdot I>$).
 - Then $t_{Dyn.Lim.}$ is the delay time that is calculated from this $I_{Dyn.Lim.}$ based on the selected characteristic.
 - (The diagram of each characteristic curve shows this “knee-point”, assuming the example value $I_{Dyn.Lim.} = 20 \cdot I>$ [EF Curve: $30 \cdot I>$].)

12.2.1.1 DEFT - Definite Time-Overcurrent ($I >$, $I >>$, $I >>>$)

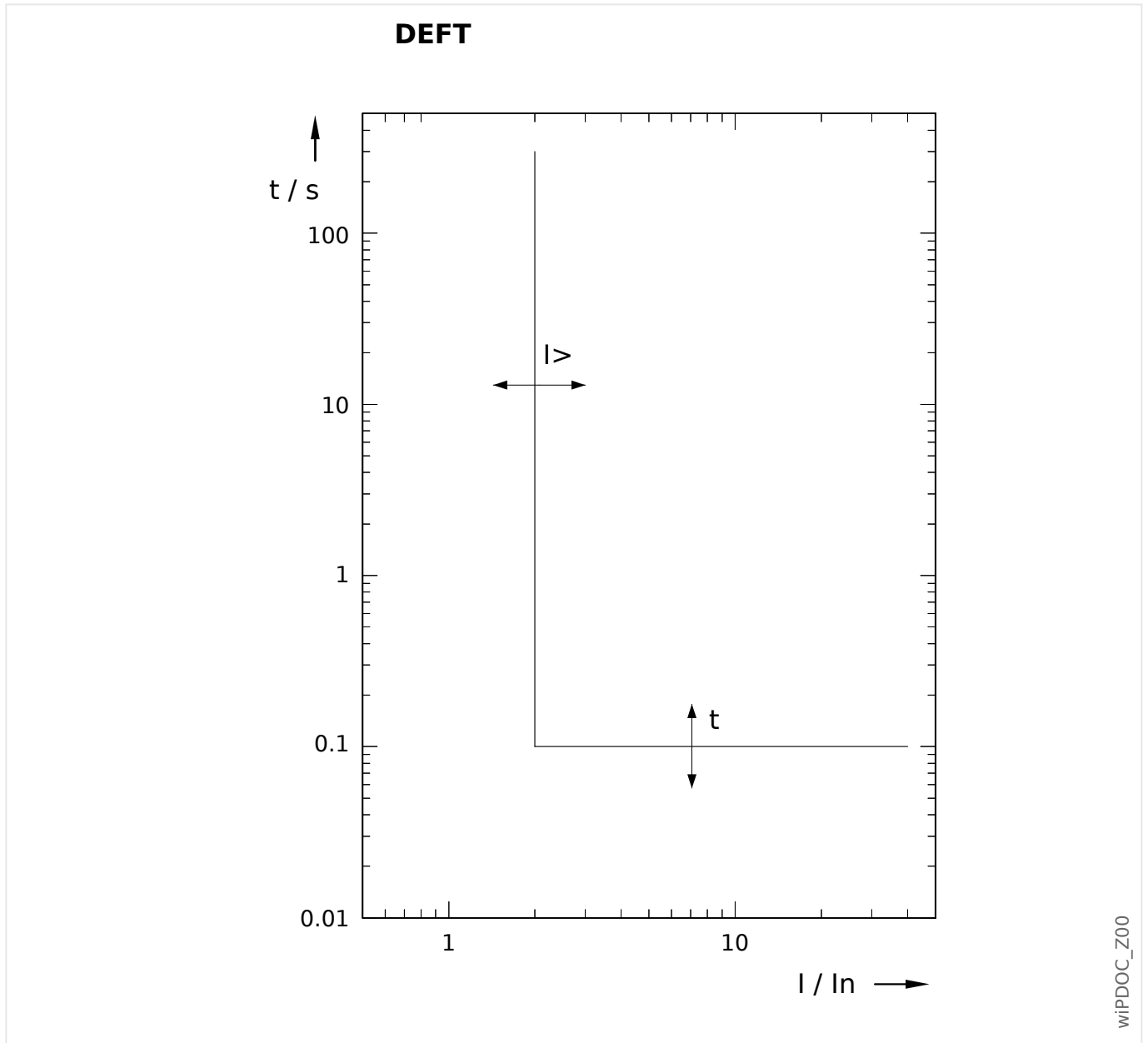

wIPDOC_Z00

Trip delay for $I > I_{>}$, settable via [Protection Para / $I >$] »t«.

The reset delay for $I < I_{>}$ always equals 0 ("instantaneous").

12.2.1.2 Inverse-Time Characteristics (I>, I>>, I>>>)

Characteristic »Char«	Trip Delay			Reset Delay (only for »Reset Mode« = "inverse time")	
	$t = \left(\frac{k}{\left(\frac{I}{I>}\right)^\alpha - 1} + c \right) \cdot tChar$			$t = \frac{\tau}{1 - \left(\frac{I}{I>}\right)^\alpha} \cdot tChar$	
	k [s]	c [s]	α	τ [s]	α
IEC NINV	0.14	0	0.02	0.14	2
IEC VINV	13.5	0	1	13.5	2
IEC EINV	80	0	2	80	2
IEC LINV	120	0	1	120	2
IEEE MINV	0.0515	0.1140	0.02	4.85	2
IEEE VINV	19.61	0.491	2	21.6	2
IEEE EINV	28.2	0.1217	2	29.1	2

Characteristic »Char«	Trip Delay			Reset Delay (only for »Reset Mode« = "inverse time")	
	$t = \frac{k}{b - \frac{c}{\left(\frac{I}{I>}\right)}} \cdot tChar$			$t = \frac{\tau}{1 - \left(\frac{I}{I>}\right)^\alpha} \cdot tChar$	
	k [s]	b	c	τ [s]	α
RINV	1.0	0.339	0.236	1.0	2

Characteristic »Char«		Trip Delay			
		$t = k \cdot t_{Char} \cdot 10^{\alpha \cdot \log(b \cdot \frac{I}{I_{>}}) + c}$			
		k [s]	b	c	α
HV Fuse		10	2	3.66	-3.8320
FR Fuse	$1 < \frac{I}{I_{>}} < 2$	10	1	3.0	-7.16
	$2 < \frac{I}{I_{>}} < 2.66$	10	1	2.47	-5.4
	$2.66 < \frac{I}{I_{>}} < \frac{I_{max}}{I_{>}}$	10	1	1.98	-4.24

See ↪“Explanation for All Characteristics (I>, I>>, I>>>)” for more information.

12.2.1.2.1 IEC 60255-151 Curves (I_>, I_{>>}, I_{>>>})

12.2.1.2.1.1 Normal Inverse (IEC 60255-151)

»Char« = IEC NINV

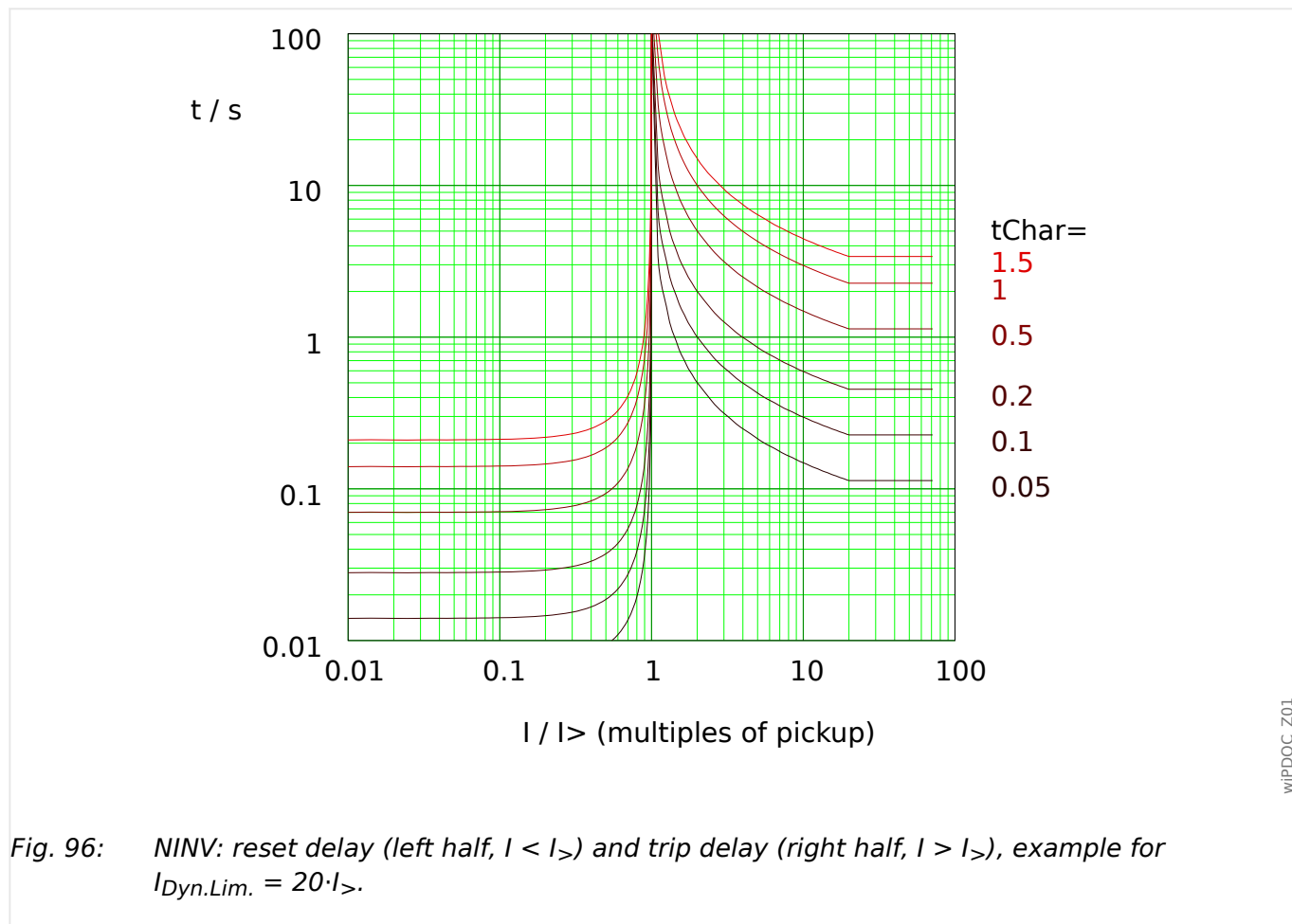

See ↪“Explanation for All Characteristics (I_>, I_{>>}, I_{>>>})” and ↪12.2.1.2 Inverse-Time Characteristics (I_>, I_{>>}, I_{>>>}) for details.

Reset Delay

Various reset modes are available: Resetting [via characteristic](#), delayed and instantaneous.

Trip Delay

If $I_{>} < I < I_{Dyn.Lim.}$, the trip delay is defined [by the characteristic](#).

For $I > I_{Dyn.Lim.}$, the trip delay t is kept constant at $t = t_{Dyn.Lim.}$.

»Char« = IEC VINV

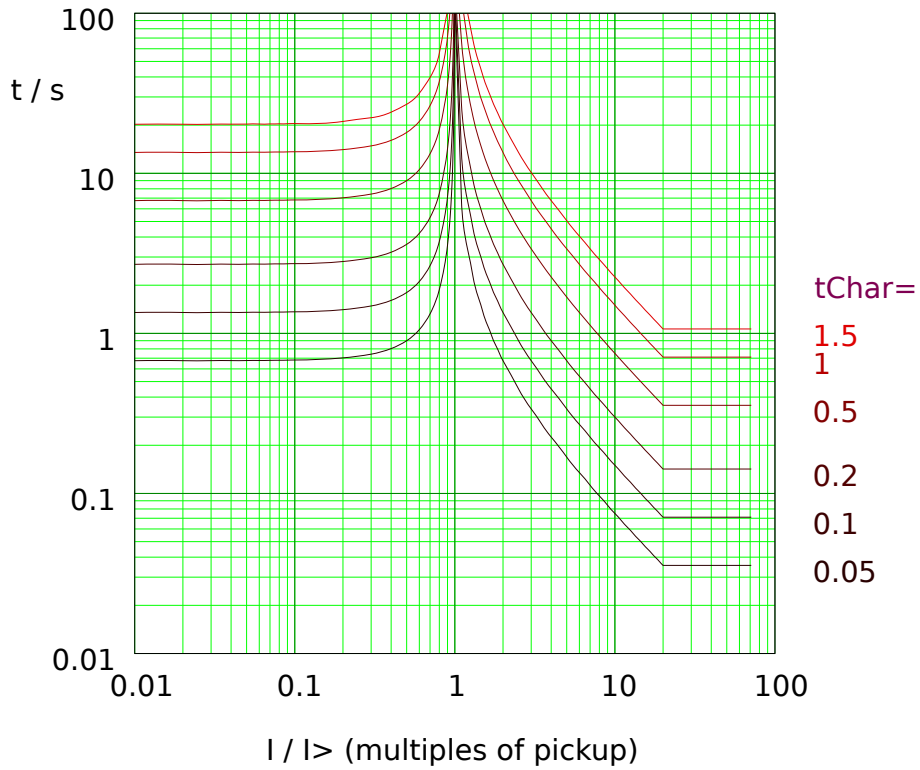

Fig. 97: VINV: reset delay (left half, $I < I_{>}$) and trip delay (right half, $I > I_{>}$), example for $I_{Dyn.Lim.} = 20 \cdot I_{>}$.

wIPDOC_Z02

See ↪“Explanation for All Characteristics ($I_{>}$, $I_{>>}$, $I_{>>>}$)” and ↪12.2.1.2 Inverse-Time Characteristics ($I_{>}$, $I_{>>}$, $I_{>>>}$) for details.

Reset Delay

Various reset modes are available: Resetting via characteristic, delayed and instantaneous.

Trip Delay

If $I_{>} < I < I_{Dyn.Lim.}$, the trip delay is defined by the characteristic.

For $I > I_{Dyn.Lim.}$, the trip delay t is kept constant at $t = t_{Dyn.Lim.}$.

12.2.1.2.1.3 Extremely Inverse - Characteristic (IEC 60255-151) - Phase Overcurrent Protection

»Char« = IEC EINV

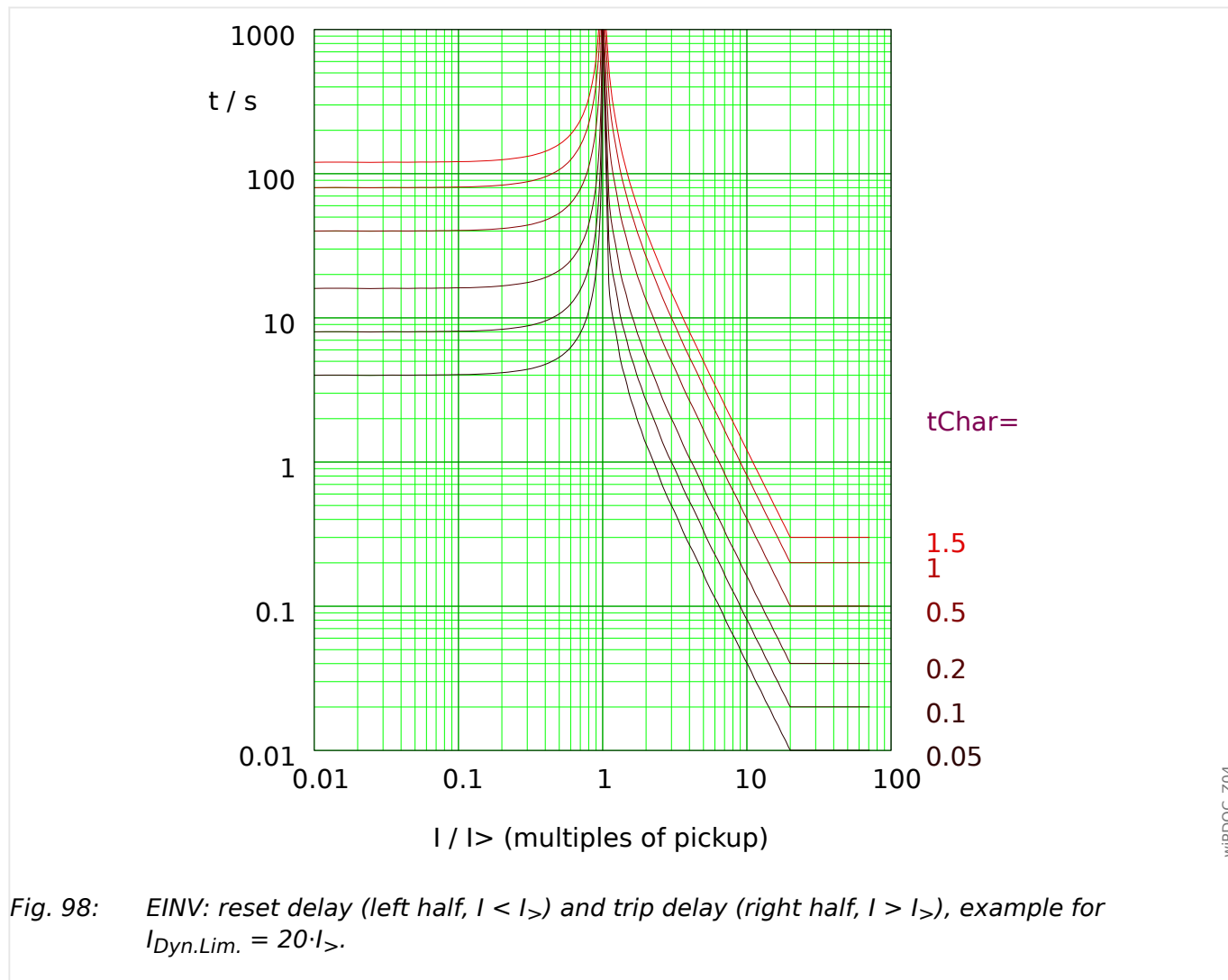

See ↪“Explanation for All Characteristics ($I_{>}$, $I_{>>}$, $I_{>>>}$)” and ↪12.2.1.2 Inverse-Time Characteristics ($I_{>}$, $I_{>>}$, $I_{>>>}$) for details.

Reset Delay

Various reset modes are available: Resetting [via characteristic](#), delayed and instantaneous.

Trip Delay

If $I_{>} < I < I_{Dyn.Lim.}$, the trip delay is defined [by the characteristic](#).

For $I > I_{Dyn.Lim.}$, the trip delay t is kept constant at $t = t_{Dyn.Lim.}$.

»Char« = IEC LINV

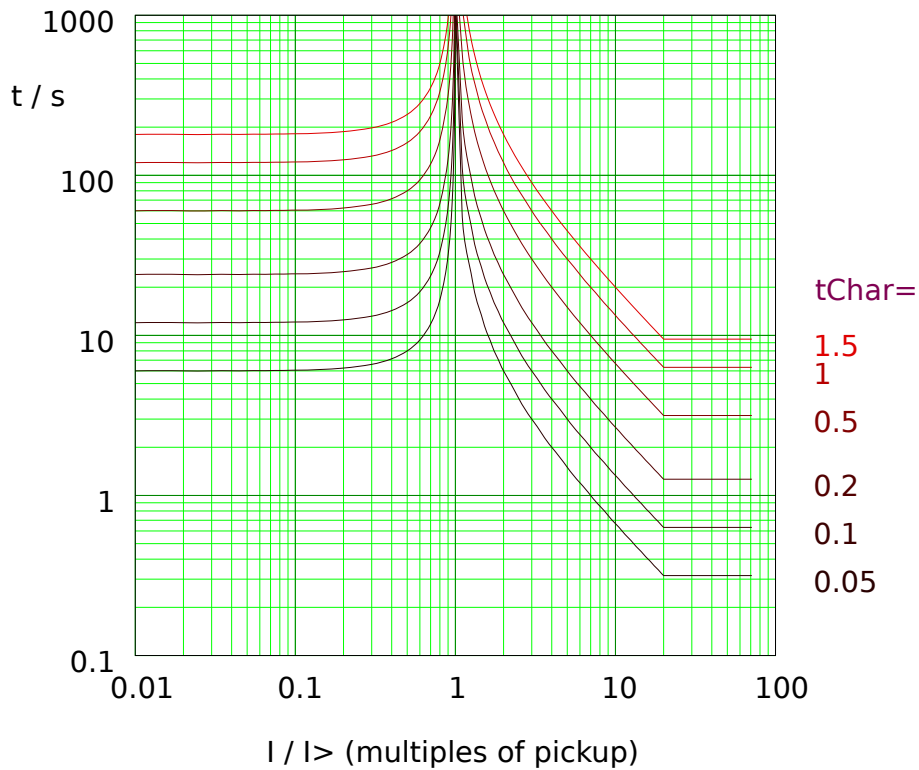

Fig. 99: LINV: reset delay (left half, $I < I_{>}$) and trip delay (right half, $I > I_{>}$), example for $I_{Dyn.Lim.} = 20 \cdot I_{>}$.

See ↪“Explanation for All Characteristics ($I_{>}$, $I_{>>}$, $I_{>>>}$)” and ↪12.2.1.2 Inverse-Time Characteristics ($I_{>}$, $I_{>>}$, $I_{>>>}$) for details.

Reset Delay

Various reset modes are available: Resetting via characteristic, delayed and instantaneous.

Trip Delay

If $I_{>} < I < I_{Dyn.Lim.}$, the trip delay is defined by the characteristic.

For $I > I_{Dyn.Lim.}$, the trip delay t is kept constant at $t = t_{Dyn.Lim.}$.

12.2.1.2.2 R Inverse [RINV] - Characteristic

»Char« = RINV

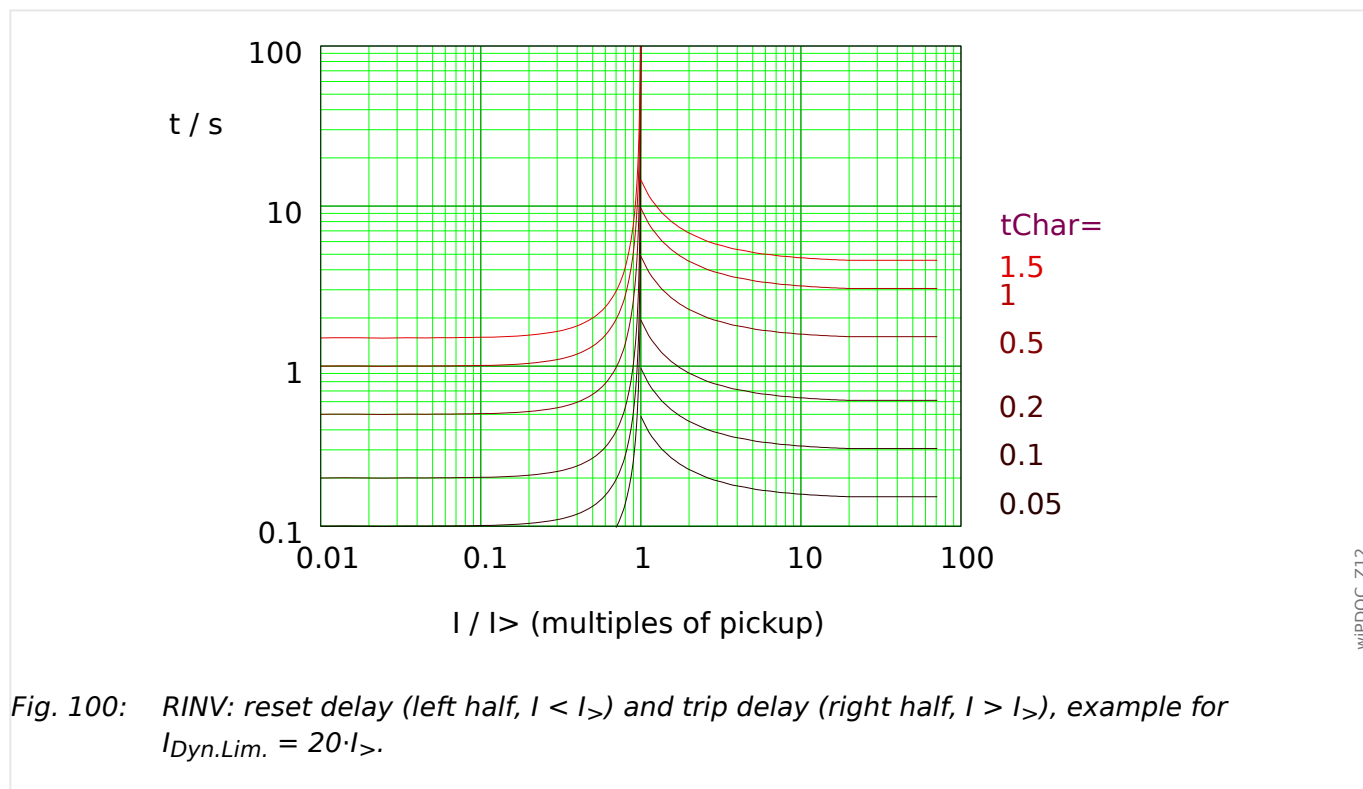

See ↪“Explanation for All Characteristics ($I_{>}$, $I_{>>}$, $I_{>>>}$)” and ↪12.2.1.2 Inverse-Time Characteristics ($I_{>}$, $I_{>>}$, $I_{>>>}$) for details.

Reset Delay

Various reset modes are available: Resetting [via characteristic](#), delayed and instantaneous.

Trip Delay

If $I_{>} < I < I_{Dyn.Lim.}$, the trip delay is defined [by the characteristic](#).

For $I > I_{Dyn.Lim.}$, the trip delay t is kept constant at $t = t_{Dyn.Lim.}$.

12.2.1.2.3 Fuse Characteristic of an HV Fuse - Phase Overcurrent Protection

»Char« = HV Fuse

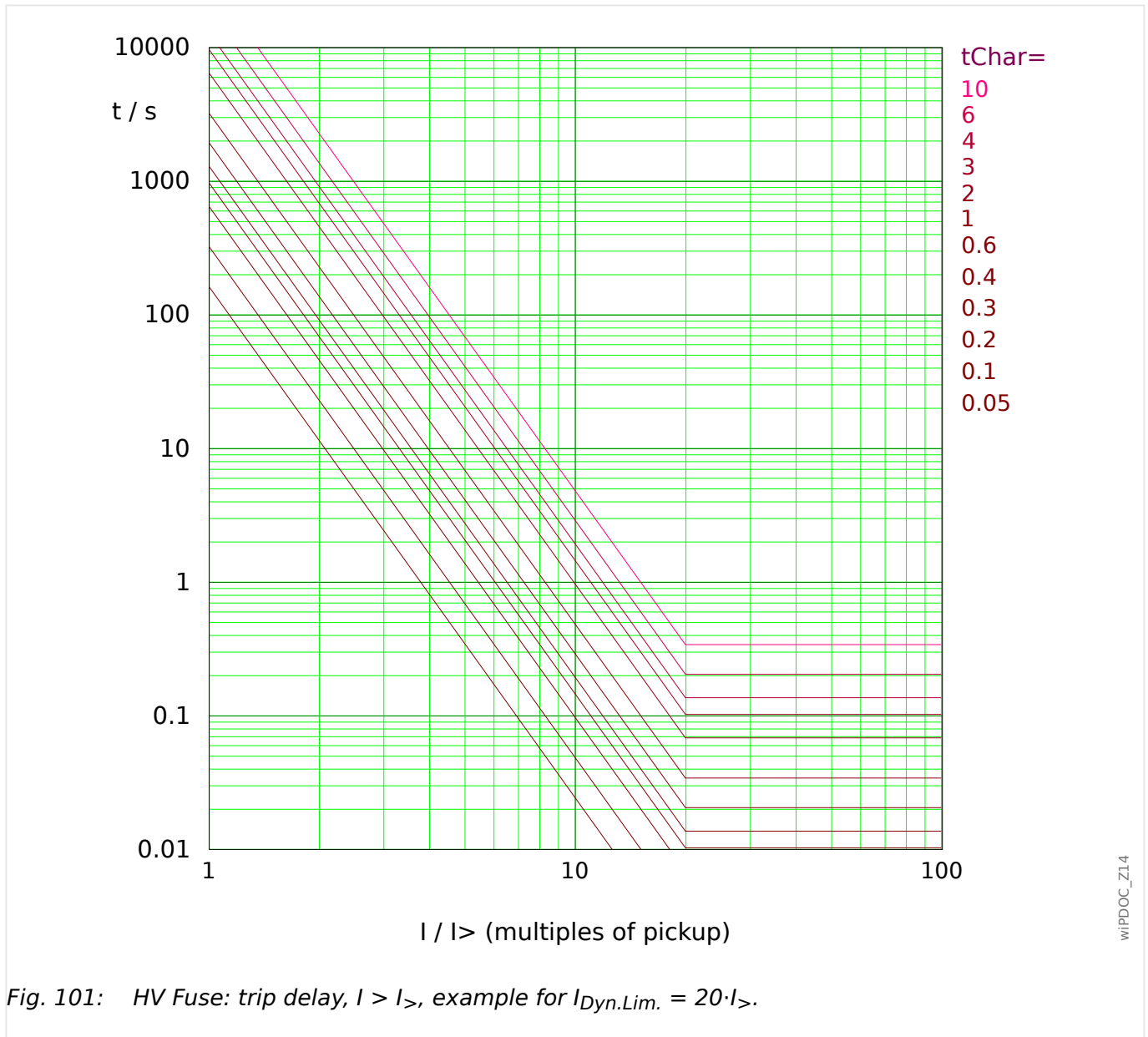

Fig. 101: HV Fuse: trip delay, $I > I_{>}$, example for $I_{Dyn.Lim.} = 20 \cdot I_{>}$.

See ↪“Explanation for All Characteristics ($I_{>}$, $I_{>>}$, $I_{>>>}$)” and ↪12.2.1.2 Inverse-Time Characteristics ($I_{>}$, $I_{>>}$, $I_{>>>}$) for details.

Reset Delay

The reset modes “instantaneous” or “definite time” are available. For this characteristic, there is no reset mode with dynamic reset delay.

Trip Delay

If $I_{>} < I < I_{Dyn.Lim.}$, the trip delay is defined by the characteristic.

For $I > I_{Dyn.Lim.}$, the trip delay t is kept constant at $t = t_{Dyn.Lim.}$.

12.2.1.2.4 Fuse Characteristic of a Full Range Fuse (FR-Fuse) – Phase Overcurrent Protection

»Char« = FR Fuse

Remark: This characteristic is sometimes also called the “Sweden curve”.

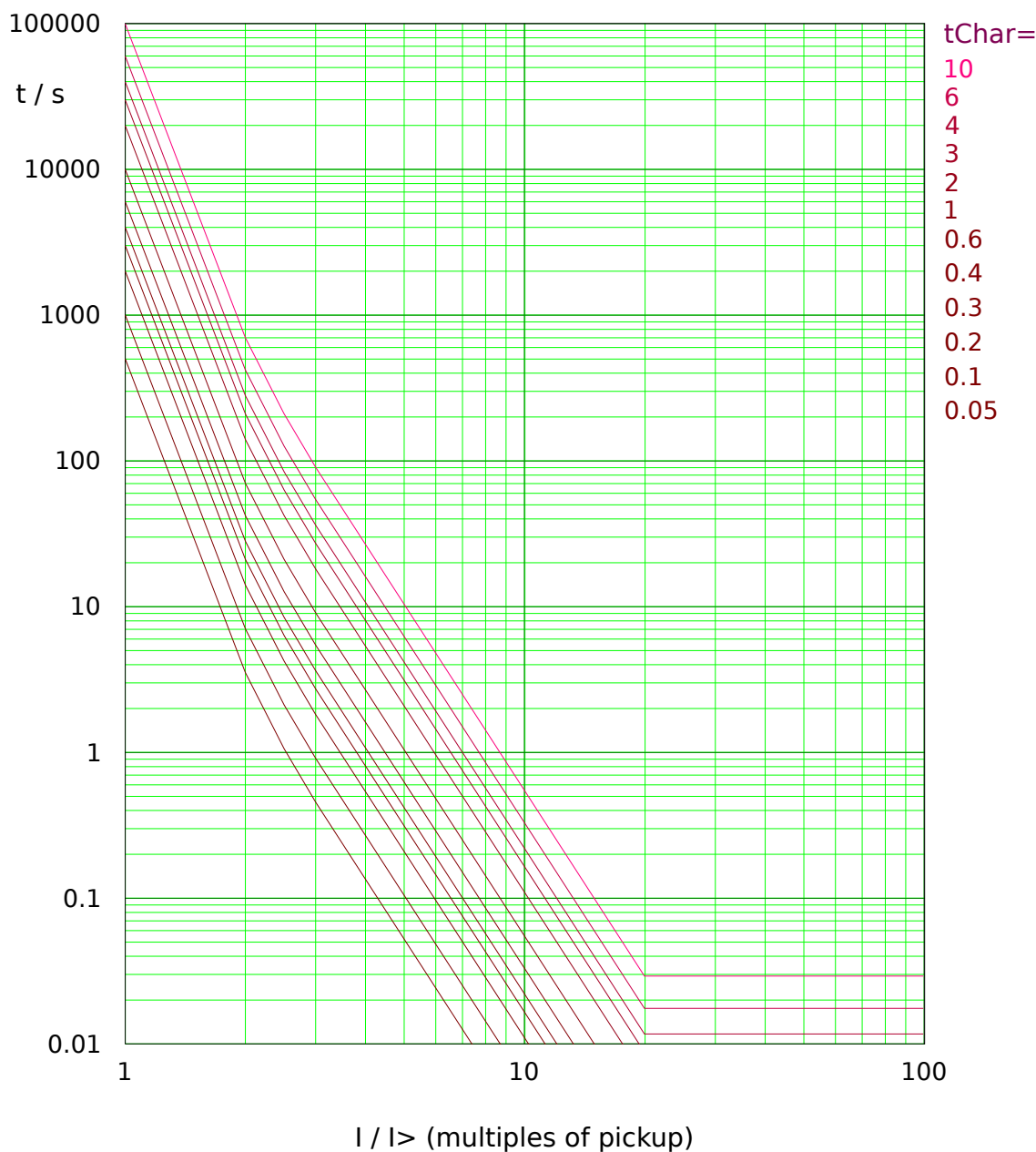
Fig. 102: FR Fuse: trip delay, $I > I_{>}$, example for $I_{Dyn.Lim.} = 20 \cdot I_{>}$.

See ↪“Explanation for All Characteristics ($I_{>}$, $I_{>>}$, $I_{>>>}$)” and ↪12.2.1.2 Inverse-Time Characteristics ($I_{>}$, $I_{>>}$, $I_{>>>}$) for details.

Reset Delay

The reset modes “instantaneous” or “definite time” are available. For this characteristic, there is no reset mode with dynamic reset delay.

Trip Delay

If $I_s < I < I_{Dyn.Lim.}$, the trip delay is defined by the characteristic.

For $I > I_{Dyn.Lim.}$, the trip delay t is kept constant at $t = t_{Dyn.Lim.}$.

12.2.1.2.5 IEEE C37.112 Curves ($I_{>}$, $I_{>>}$, $I_{>>>}$)

12.2.1.2.5.1 Moderately Inverse [MINV] - Characteristic (IEEE C37.112) - Phase Overcurrent Protection

»Char« = "IEEE MINV"

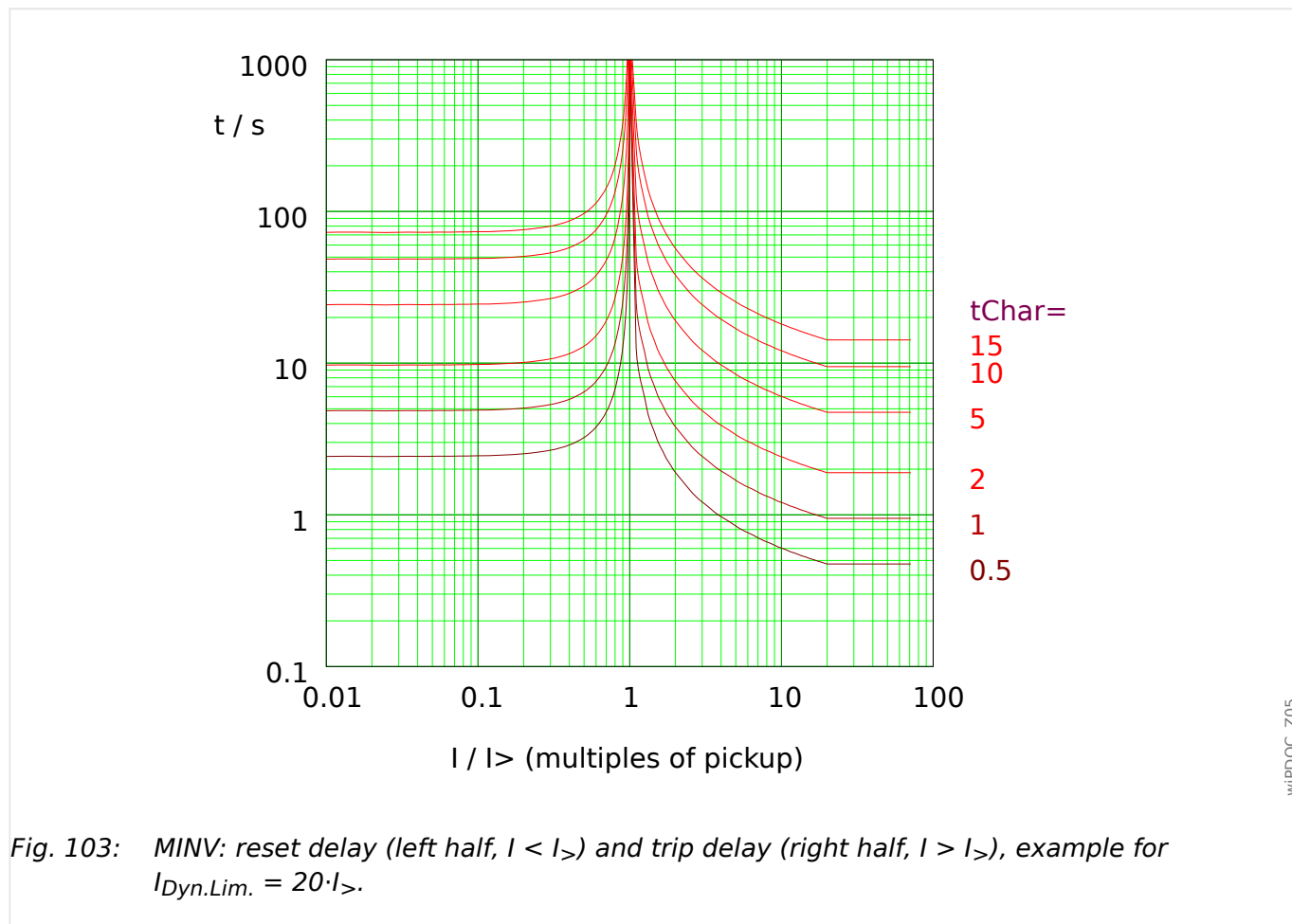

See ↪“Explanation for All Characteristics ($I_{>}$, $I_{>>}$, $I_{>>>}$)” and ↪12.2.1.2 Inverse-Time Characteristics ($I_{>}$, $I_{>>}$, $I_{>>>}$) for details.

Reset Delay

Various reset modes are available: Resetting [via characteristic](#), delayed and instantaneous.

Trip Delay

If $I_{>} < I < I_{Dyn.Lim.}$, the trip delay is defined [by the characteristic](#).

For $I > I_{Dyn.Lim.}$, the trip delay t is kept constant at $t = t_{Dyn.Lim.}$.

12.2.1.2.5.2 Very Inverse [VINV] (IEEE C37.112) - Phase Overcurrent Protection

»Char« = "IEEE VINV"

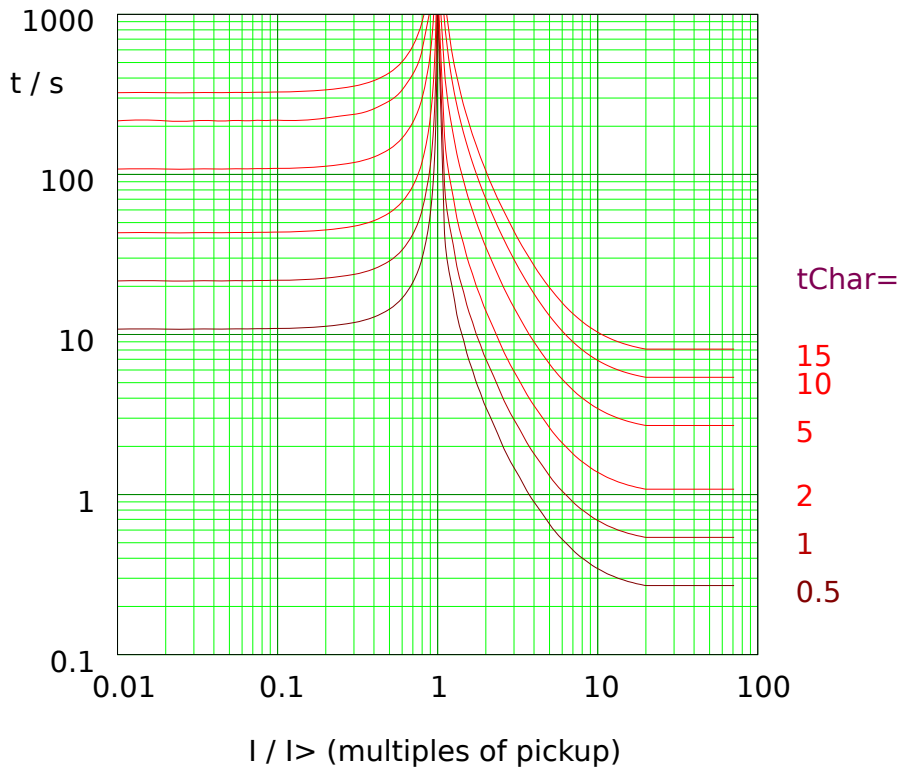

Fig. 104: VINV: reset delay (left half, $I < I_p$) and trip delay (right half, $I > I_p$), example for $I_{Dyn.Lim.} = 20 \cdot I_p$.

See ↪“Explanation for All Characteristics (I_p , $I_{>>}$, $I_{>>>}$)” and ↪12.2.1.2 Inverse-Time Characteristics (I_p , $I_{>>}$, $I_{>>>}$) for details.

Reset Delay

Various reset modes are available: Resetting via characteristic, delayed and instantaneous.

Trip Delay

If $I_p < I < I_{Dyn.Lim.}$, the trip delay is defined by the characteristic.

For $I > I_{Dyn.Lim.}$, the trip delay t is kept constant at $t = t_{Dyn.Lim.}$.

12.2.1.2.5.3 Extremely Inverse - Characteristic (IEEE C37.112) - Phase Overcurrent Protection

»Char« = "IEEE EINV"

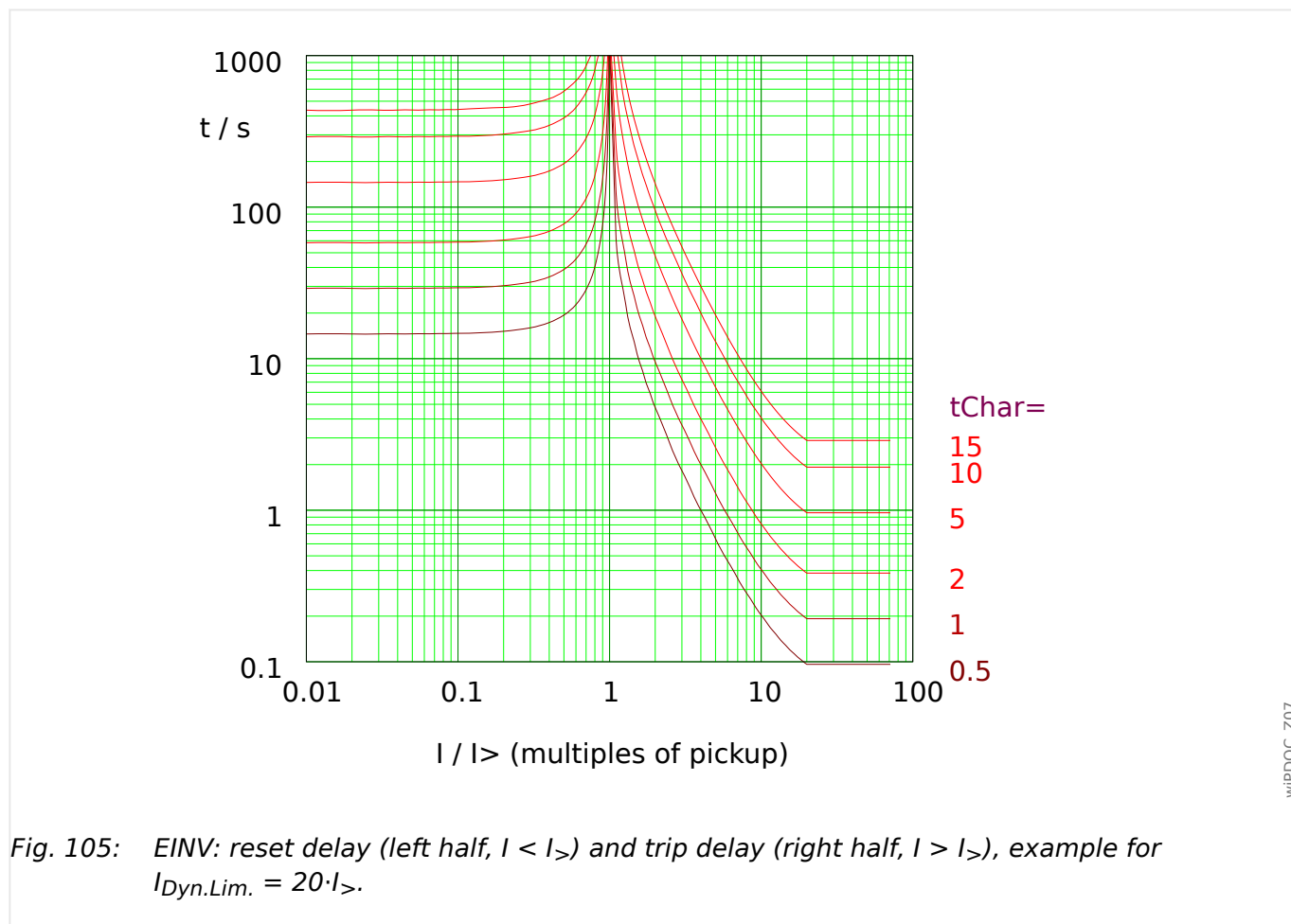

See ↪“Explanation for All Characteristics ($I_{>}$, $I_{>>}$, $I_{>>>}$)” and ↪12.2.1.2 Inverse-Time Characteristics ($I_{>}$, $I_{>>}$, $I_{>>>}$) for details.

Reset Delay

Various reset modes are available: Resetting [via characteristic](#), delayed and instantaneous.

Trip Delay

If $I_{>} < I < I_{Dyn.Lim.}$, the trip delay is defined [by the characteristic](#).

For $I > I_{Dyn.Lim.}$, the trip delay t is kept constant at $t = t_{Dyn.Lim.}$.

12.2.1.2.6 “EF” Curve - Phase Overcurrent Protection

»Char« = EF Curve

See [↪“Explanation for All Characteristics \(I>, I>>, I>>>\)”](#) for details.

Reset Delay

The reset modes “instantaneous” or “definite time” are available. For this characteristic, there is no reset mode with dynamic reset delay.

Trip Delay

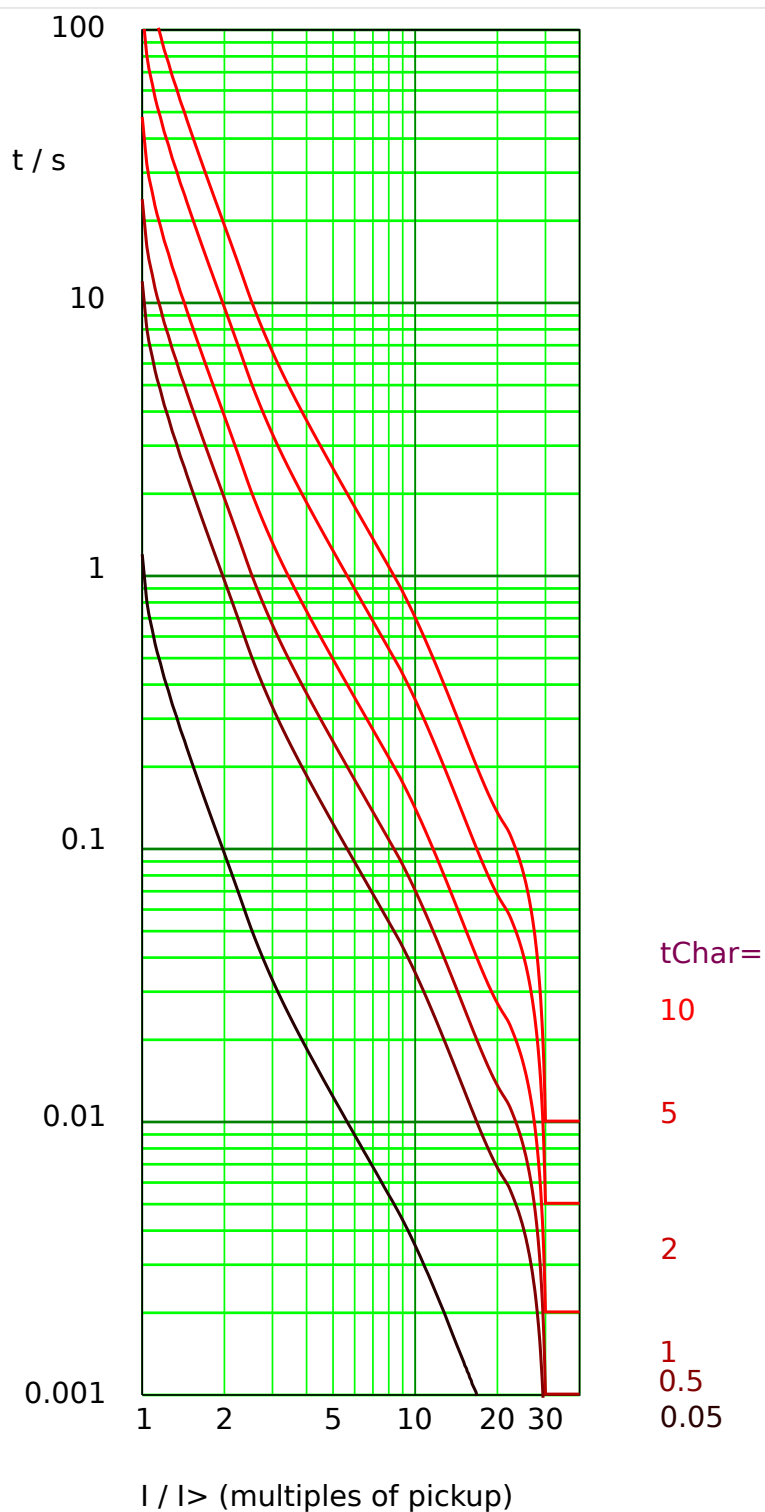

Fig. 106: EF Curve: trip delay, $I > I_{>}$, example for $I_{Dyn.Lim.} = 30 \cdot I_{>}$.

wiPDOC_Z16

12.2.2 Characteristics (IG>, IG>>)

For each ground (earth) overcurrent stage the following characteristics are available:

- **DEFT** - *Definite Time-Overcurrent*
- **IEC 60255-151 Curves:**
 - **NINV** - *IEC Normal Inverse* (IEC 60255-151)
 - **VINV** - *IEC Very Inverse* (IEC 60255-151)
 - **LINV** - *IEC Long Time Inverse* (IEC 60255-151)
 - **EINV** - *IEC Extremely Inverse* (IEC 60255-151)
- **RINV** - *R Inverse*
- **HV Fuse** Fuse Characteristic of an HV Fuse
- **FR Fuse** Fuse Characteristic of a Full Range Fuse
- **Curves Defined in IEEE C37.112:**
 - **MINV** - *IEEE Moderately Inverse* (IEEE C37.112)
 - **VINV** - *IEEE Very Inverse* (IEEE C37.112)
 - **EINV** - *IEEE Extremely Inverse* (IEEE C37.112)
- **EF Curve** “EF” Curve
- **RXIDG**

Explanation for All Characteristics (IG>, IG>>)

(Remark: All settings are given for protection stage »IG>«. »IG>>« has the same settings with corresponding menu branches.)

- **IG:** Pickup value for the protection stage. If the pickup value is exceeded, the stage starts to time out to trip.
- **IG> = I_{G>}:** If the pickup value is exceeded, the module/stage will be started.

Setting: [Protection Para / IG>] »IG«

- Trip delay t for $IG > I_{G>}$:
 - for »Char« = “**DEFT**”: settable via [Protection Para / IG>] » t «.
 - for all other characteristics: calculated based on the selected curve.
- Reset mode for $IG < I_{G>}$, settable via »Reset Mode«, available options:
 - With option »Reset Mode« = “instantaneous”: Instantaneous reset: when the current drops below the pickup setting, the TOC time resets to zero within 2 cycles.
 - With option »Reset Mode« = “definite time”: The reset delay is settable at » t_{Reset} «.

- With option »Reset Mode« = “inverse time” (only available for IEC and ANSI/IEEE curves): The reset delay is calculated based on the selected characteristics.
- tChar (for all characteristics except “DEFT”):
 - Time multiplier/tripping characteristic factor. The setting range depends on the selected tripping curve.
 - Setting via [Protection Para / IG>] »tChar«

For all inverse-time characteristics (i. e. all curves except the DEFT), there are two minimum trip delays, and independent of the selected characteristic will the actual trip delay never be smaller than any of these two minimum delays.

- »IG> . tMinimum« is a minimum delay settable by the user. So, this is simply a timer that is triggered independent of the inverse-time curve and that has to elapse before the protection stage trips. If it is set to 0 seconds it is deactivated. (See also ↪5.5.2.1 Earth (Ground) Overcurrent Protection - Settings via Smart view (PC) or DiggiMEC.)
- Another minimum delay, $t_{Dyn.Lim.}$, results from a calculated “knee-point” of the characteristic. This means it is dependent on a particular current value on the curve, $I_{G,Dyn.Lim.}$. The effective trip delay does never fall below $t_{Dyn.Lim.}$, independent of the actual value of IG.
 - $I_{G,Dyn.Lim.}$ is defined as the smallest value out of these three values:
 - $20 \cdot I_{G>}$ (EF Curve: $30 \cdot I_{G>}$),
 - $20 \cdot I_{n,max}$, if calculated ground/earth current IG_{calc} is used,
 - $20 \cdot I_{Gnom}$, if measured ground/earth current IG_{meas} is used.
 - Then $t_{Dyn.Lim.}$ is the delay time that is calculated from this $I_{G,Dyn.Lim.}$ based on the selected characteristic.
 - (The diagram of each characteristic curve shows this “knee-point”, assuming the example value $I_{G,Dyn.Lim.} = 20 \cdot I_{G>}$ [EF Curve: $30 \cdot I_{G>}$].)
 - Exception: For »Char« = “RXIDG”, $t_{Dyn.Lim.}$ is independent of $I_{G,Dyn.Lim.}$, but has the fixed value $t_{Dyn.Lim.} = 0.02$ s

12.2.2.1 DEFT - Definite Time-Overcurrent ($I_G >$, $I_G >>$)

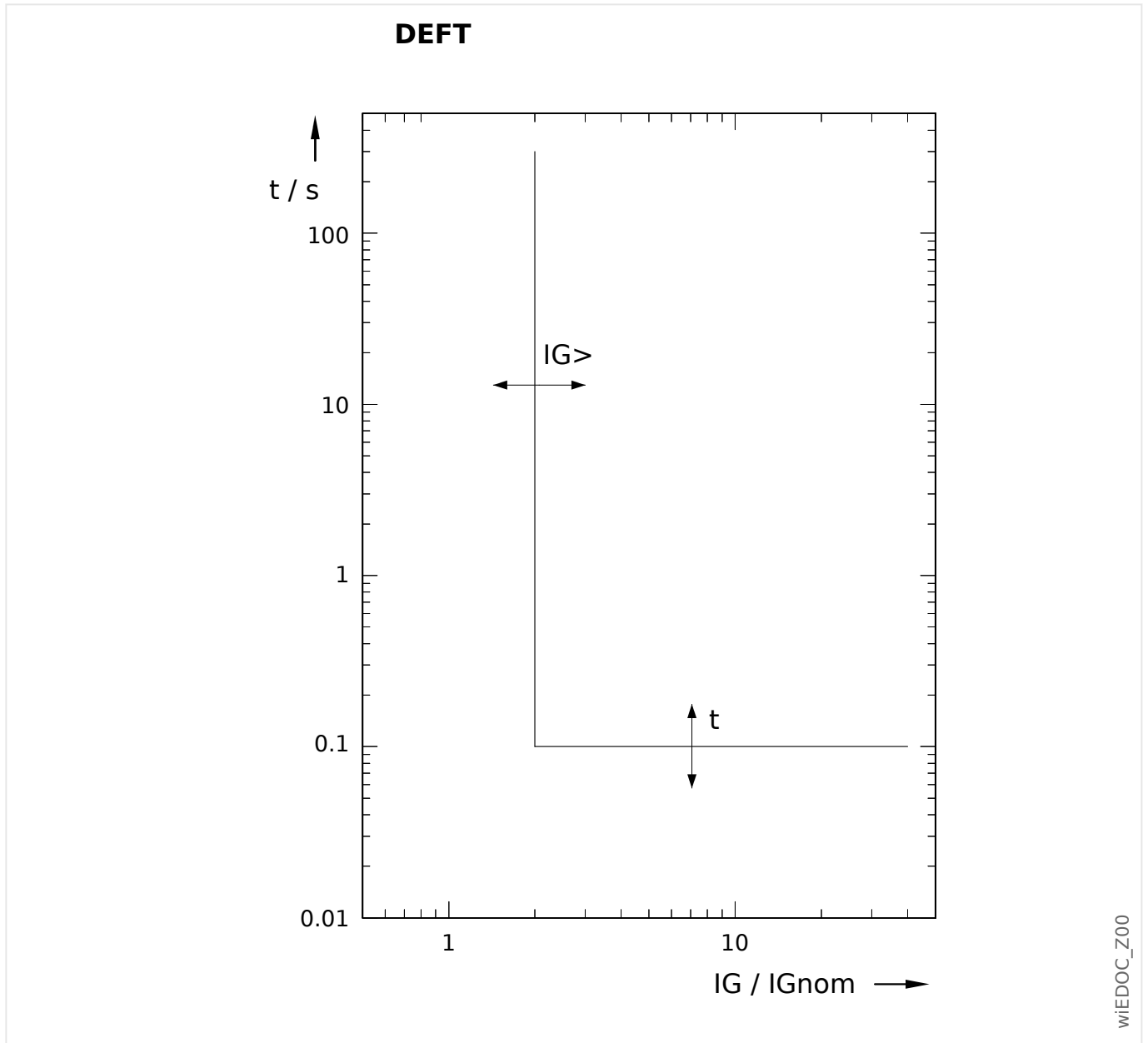

WIEDOC_Z00

Trip delay for $I_G > I_{G>}$, settable via [Protection Para / $I_G >$] »t«.

The reset delay for $I_G < I_{G>}$ always equals 0 ("instantaneous").

12.2.2.2 Inverse-Time Characteristics (IG>, IG>>)

Characteristic »Char«	Trip Delay			Reset Delay (only for »Reset Mode« = "inverse time")	
	$t = \left(\frac{k}{\left(\frac{IG}{IG>}\right)^\alpha - 1} + c \right) \cdot tChar$			$t = \frac{\tau}{1 - \left(\frac{IG}{IG>}\right)^\alpha} \cdot tChar$	
	k [s]	c [s]	α	τ [s]	α
IEC NINV	0.14	0	0.02	0.14	2
IEC VINV	13.5	0	1	13.5	2
IEC EINV	80	0	2	80	2
IEC LINV	120	0	1	120	2
IEEE MINV	0.0515	0.1140	0.02	4.85	2
IEEE VINV	19.61	0.491	2	21.6	2
IEEE EINV	28.2	0.1217	2	29.1	2

Characteristic »Char«	Trip Delay			Reset Delay (only for »Reset Mode« = "inverse time")	
	$t = \frac{k}{b - \frac{c}{\left(\frac{IG}{IG>}\right)}} \cdot tChar$			$t = \frac{\tau}{1 - \left(\frac{IG}{IG>}\right)^\alpha} \cdot tChar$	
	k [s]	b	c	τ [s]	α
RINV	1.0	0.339	0.236	1.0	2

Characteristic »Char«		Trip Delay			
		$t = k \cdot tChar \cdot 10^{\alpha \cdot \log(b \cdot \frac{IG}{IG>}) + c}$			
		k	b	c	α
HV Fuse		10	2	3.66	-3.8320
FR Fuse	$1 < \frac{IG}{IG>} < 2$	10	1	3.0	-7.16
	$2 < \frac{IG}{IG>} < 2.66$	10	1	2.47	-5.4
	$2.66 < \frac{IG}{IG>} < \frac{I_{max}}{IG>}$	10	1	1.98	-4.24

Characteristic »Char«		Trip Delay	
		$t = m - k \cdot \ln\left(\frac{IG}{IG> \cdot tChar}\right)$	
		k	m
		[s]	[s]
RXIDG		1.35	5.8

See ↪“Explanation for All Characteristics (IG>, IG>>)” for more information.

12.2.2.2.1 IEC 60255-151 Curves (IG>, IG>>)

12.2.2.2.1.1 IEC Normal Inverse (IEC 60255-151)

»Char« = IEC NINV

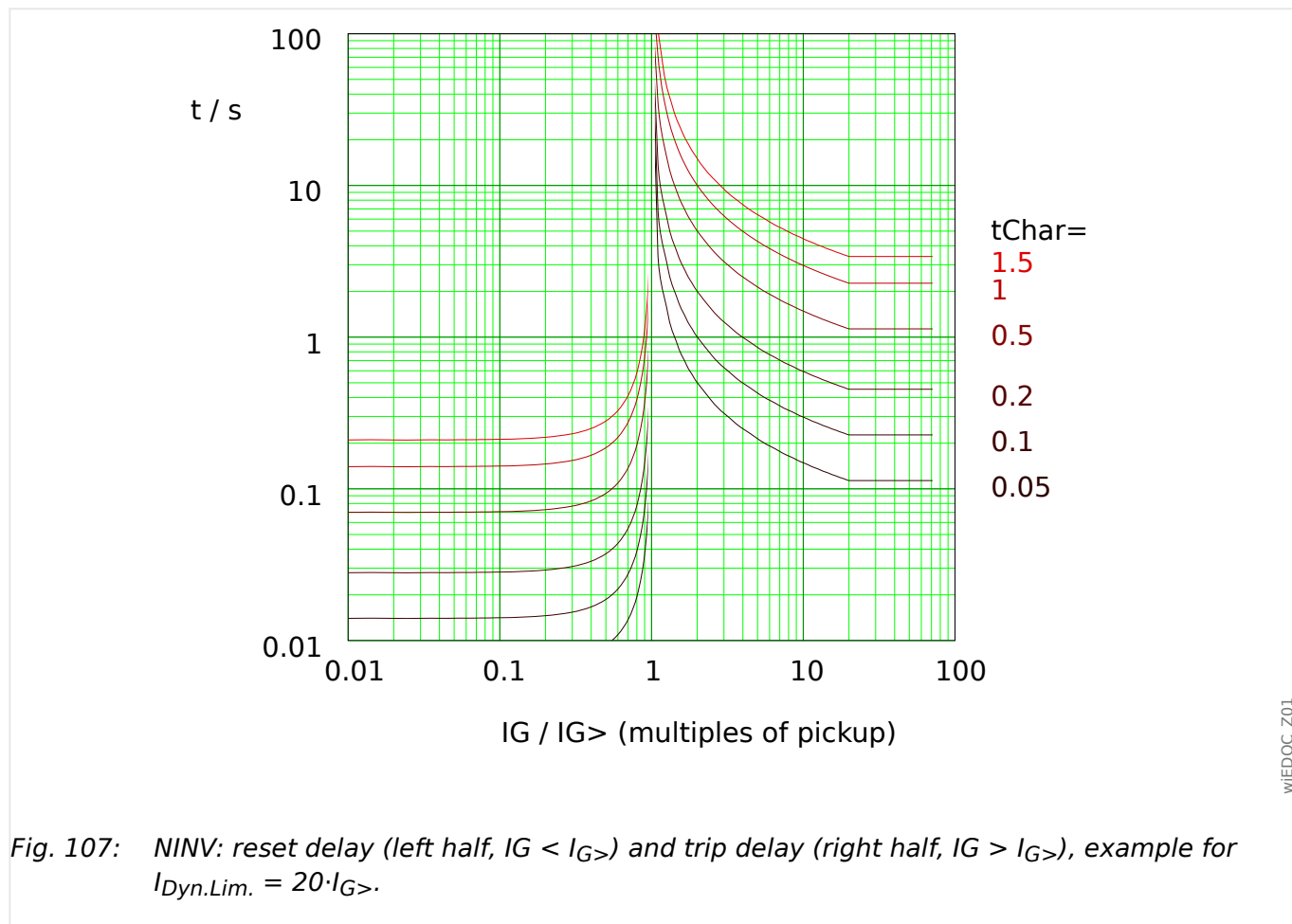

See ↪“Explanation for All Characteristics (IG>, IG>>)” and ↪12.2.2.2 Inverse-Time Characteristics (IG>, IG>>) for details.

Reset Delay

Various reset modes are available: Resetting [via characteristic](#), delayed and instantaneous.

Trip Delay

If $I_{G>} < I_G < I_{Dyn.Lim.}$, the trip delay is defined [by the characteristic](#).

For $I_G > I_{Dyn.Lim.}$, the trip delay t is kept constant at $t = t_{Dyn.Lim.}$.

»Char« = IEC VINV

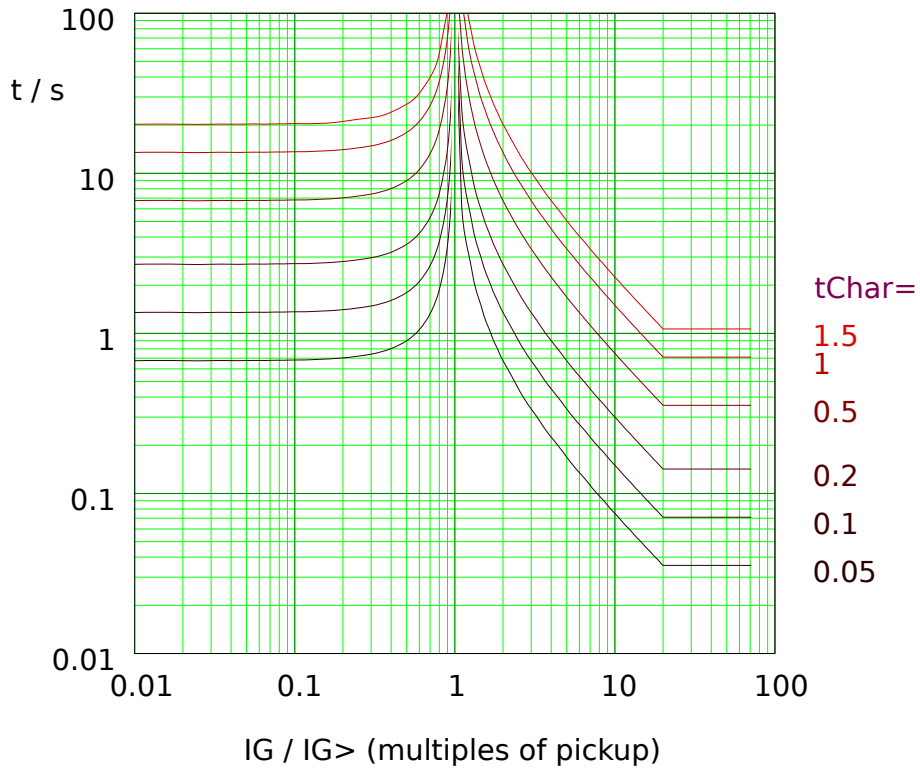

Fig. 108: VINV: reset delay (left half, $I_G < I_{G>}$) and trip delay (right half, $I_G > I_{G>}$), example for $I_{Dyn.Lim.} = 20 \cdot I_{G>}$.

See ↪“Explanation for All Characteristics ($I_{G>}$, $I_{G>>}$)” and ↪12.2.2.2 Inverse-Time Characteristics ($I_{G>}$, $I_{G>>}$) for details.

Reset Delay

Various reset modes are available: Resetting via characteristic, delayed and instantaneous.

Trip Delay

If $I_{G>} < I_G < I_{Dyn.Lim.}$, the trip delay is defined by the characteristic.

For $I_G > I_{Dyn.Lim.}$, the trip delay t is kept constant at $t = t_{Dyn.Lim.}$.

12.2.2.2.1.3 IEC Extremely Inverse - Characteristic (IEC 60255-151)

»Char« = IEC EINV

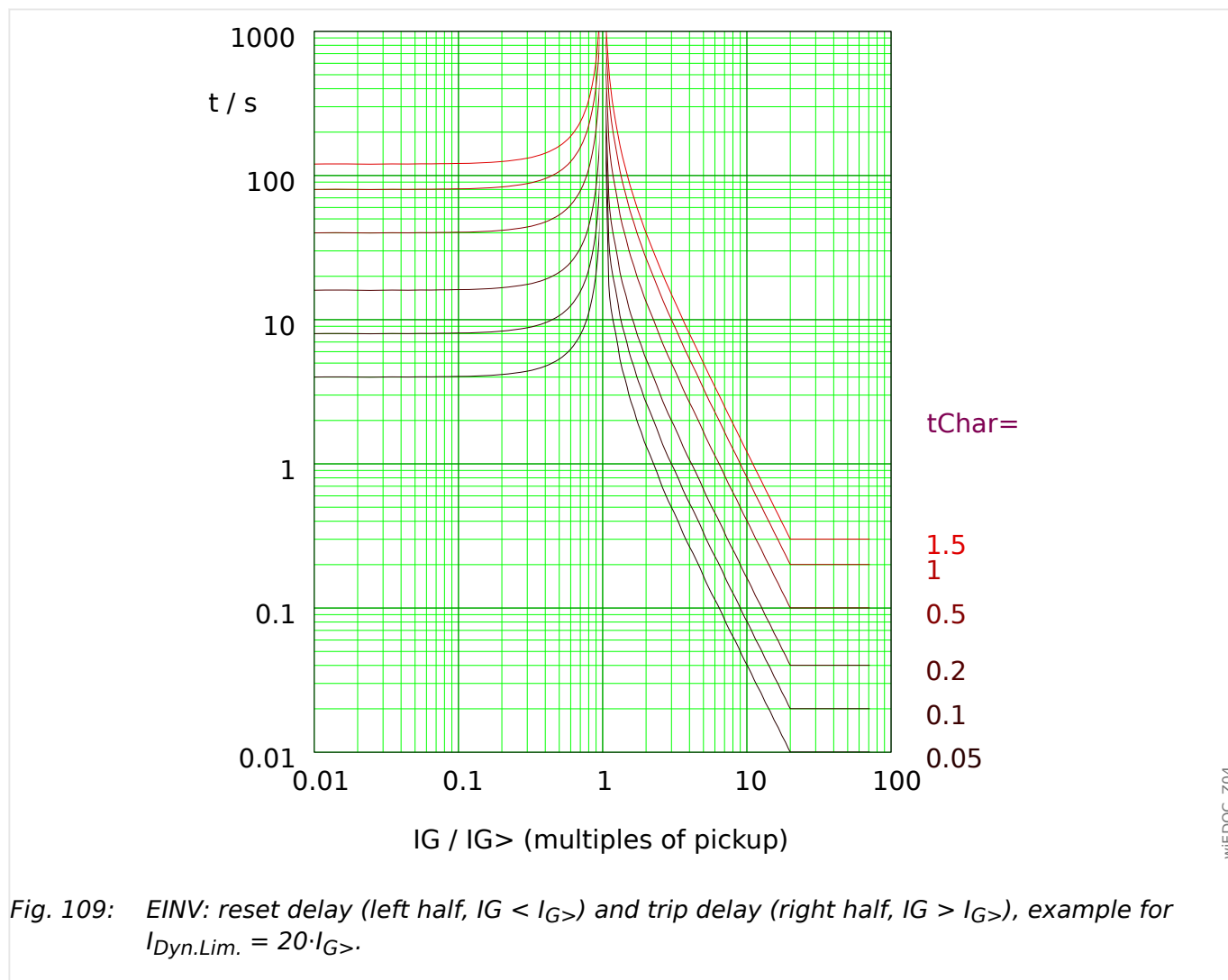

See ↪“Explanation for All Characteristics ($I_{G>}$, $I_{G>>}$)” and ↪12.2.2.2 Inverse-Time Characteristics ($I_{G>}$, $I_{G>>}$) for details.

Reset Delay

Various reset modes are available: Resetting [via characteristic](#), delayed and instantaneous.

Trip Delay

If $I_{G>} < I_G < I_{Dyn.Lim.}$, the trip delay is defined [by the characteristic](#).

For $I_G > I_{Dyn.Lim.}$, the trip delay t is kept constant at $t = t_{Dyn.Lim.}$.

»Char« = IEC LINV

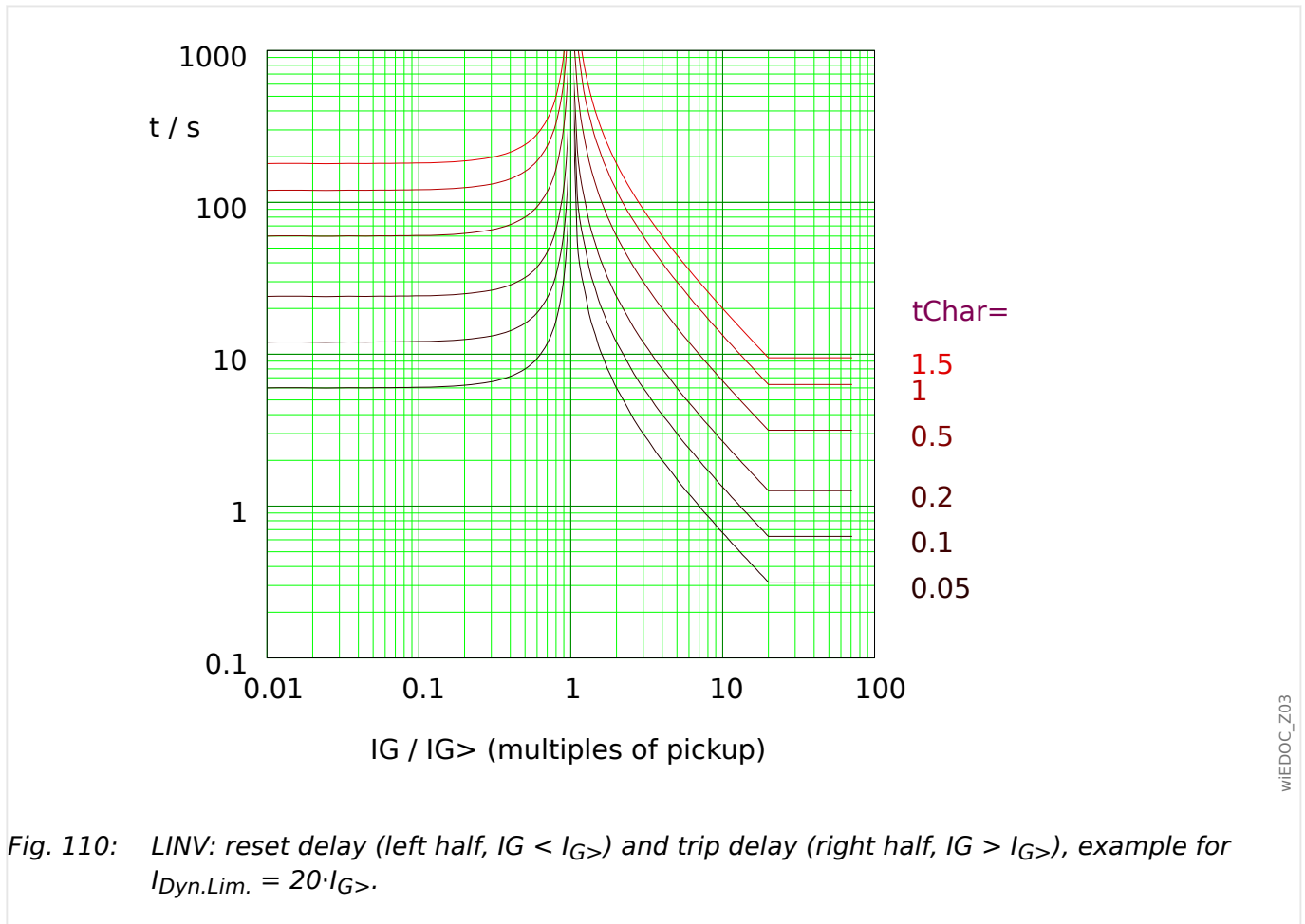

Fig. 110: LINV: reset delay (left half, $I_G < I_{G>}$) and trip delay (right half, $I_G > I_{G>}$), example for $I_{Dyn.Lim.} = 20 \cdot I_{G>}$.

See ↪“Explanation for All Characteristics ($I_{G>}$, $I_{G>>}$)” and ↪12.2.2.2 Inverse-Time Characteristics ($I_{G>}$, $I_{G>>}$) for details.

Reset Delay

Various reset modes are available: Resetting via characteristic, delayed and instantaneous.

Trip Delay

If $I_{G>} < I_G < I_{Dyn.Lim.}$, the trip delay is defined by the characteristic.

For $I_G > I_{Dyn.Lim.}$, the trip delay t is kept constant at $t = t_{Dyn.Lim.}$.

12.2.2.2.2 R Inverse [RINV] - Characteristic

»Char« = RINV

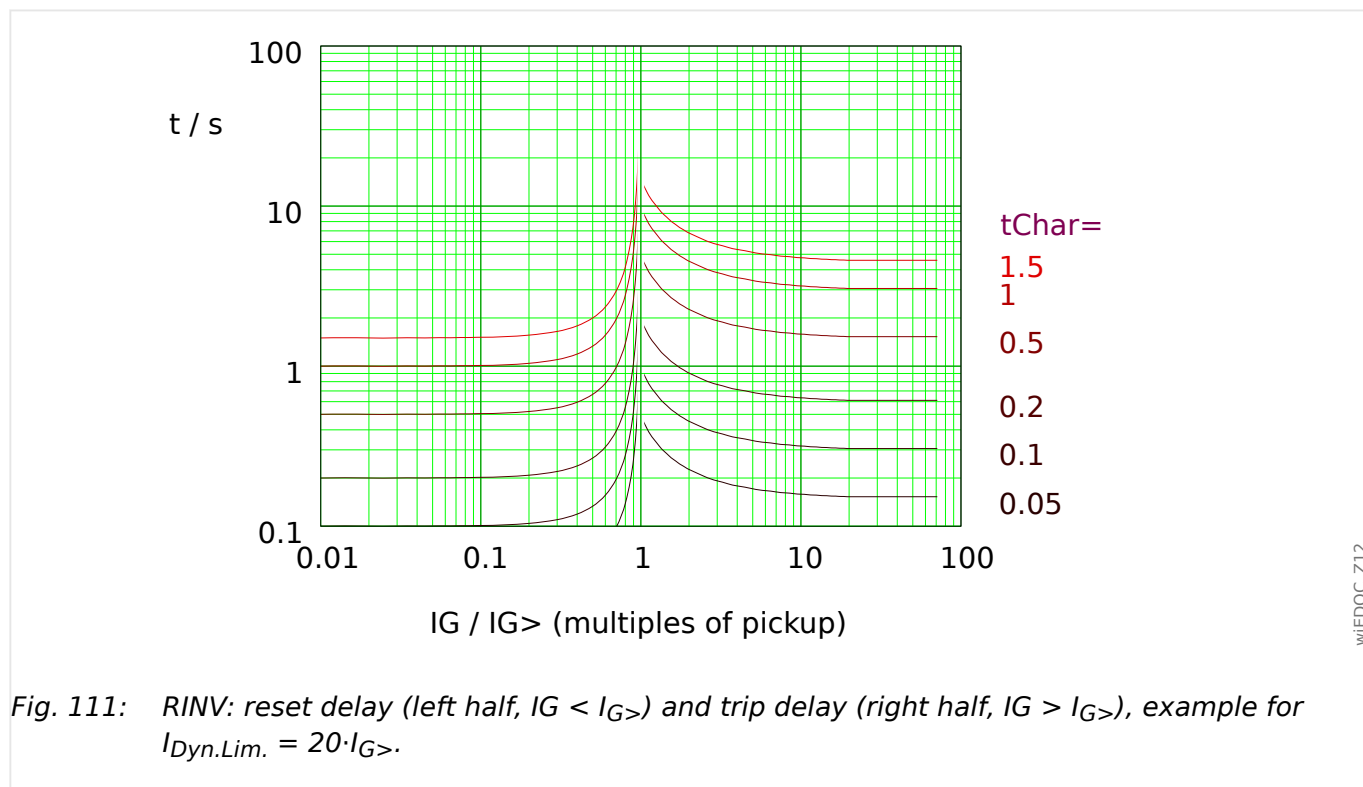

Fig. 111: RINV: reset delay (left half, $I_G < I_{G>}$) and trip delay (right half, $I_G > I_{G>}$), example for $I_{Dyn.Lim.} = 20 \cdot I_{G>}$.

See ↪“Explanation for All Characteristics ($I_{G>}$, $I_{G>>}$)” and ↪12.2.2.2 Inverse-Time Characteristics ($I_{G>}$, $I_{G>>}$) for details.

Reset Delay

Various reset modes are available: Resetting [via characteristic](#), delayed and instantaneous.

Trip Delay

If $I_{G>} < I_G < I_{Dyn.Lim.}$, the trip delay is defined [by the characteristic](#).

For $I_G > I_{Dyn.Lim.}$, the trip delay t is kept constant at $t = t_{Dyn.Lim.}$.

12.2.2.2.3 Fuse Characteristic of an HV Fuse

»Char« = HV Fuse

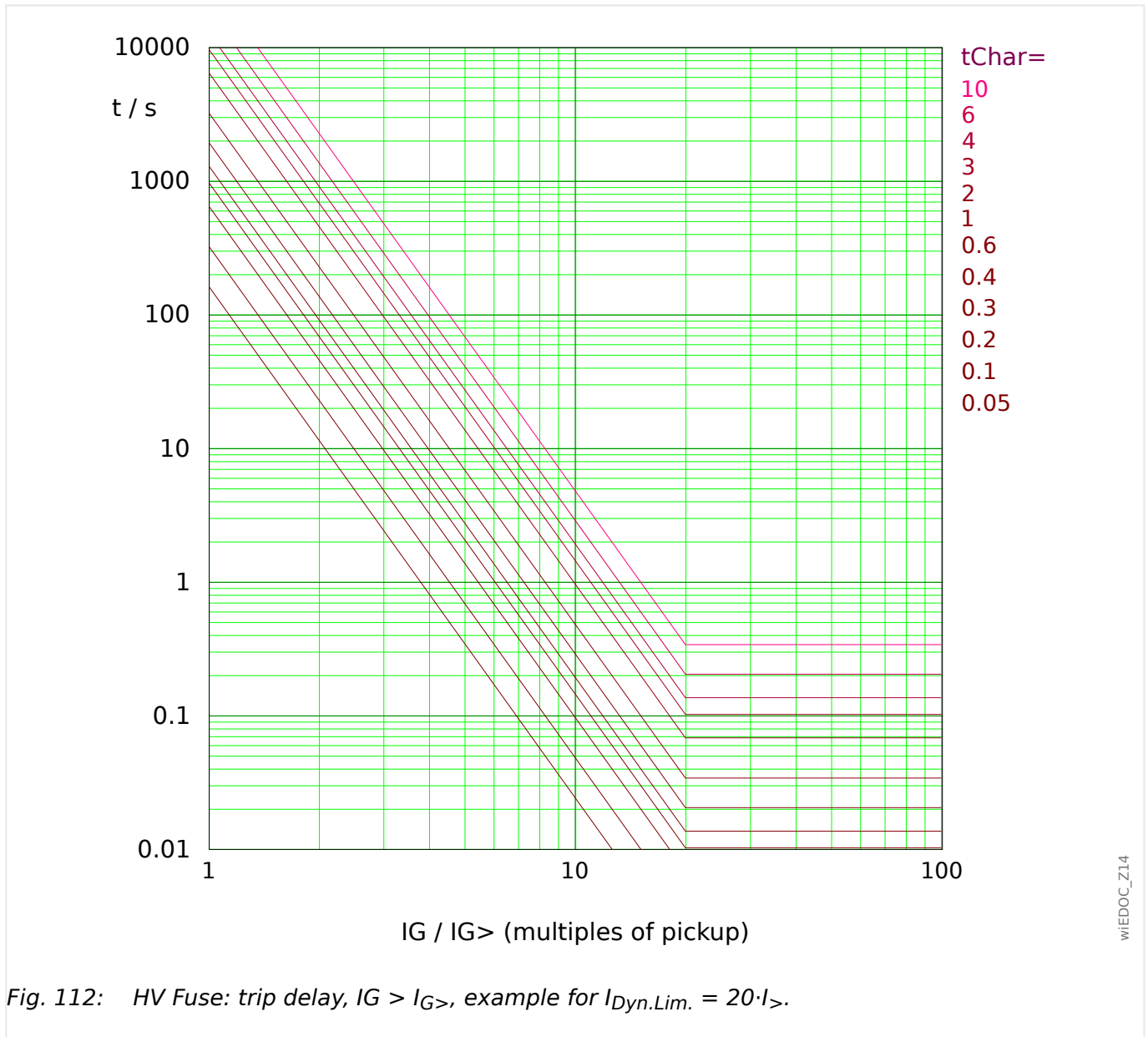

Fig. 112: HV Fuse: trip delay, $I_G > I_{G>}$, example for $I_{Dyn.Lim.} = 20 \cdot I_{G>}$.

See ↪“Explanation for All Characteristics ($I_{G>}$, $I_{G>>}$)” and ↪12.2.2.2 Inverse-Time Characteristics ($I_{G>}$, $I_{G>>}$) for details.

Reset Delay

The reset modes “instantaneous” or “definite time” are available. For this characteristic, there is no reset mode with dynamic reset delay.

Trip Delay

If $I_{G>} < I_G < I_{Dyn.Lim.}$, the trip delay is defined by the characteristic.

For $I_G > I_{Dyn.Lim.}$, the trip delay t is kept constant at $t = t_{Dyn.Lim.}$.

12.2.2.2.4 Fuse Characteristic of a Full Range Fuse (FR-Fuse)

»Char« = FR Fuse

Remark: This characteristic is sometimes also called the “Sweden curve”.

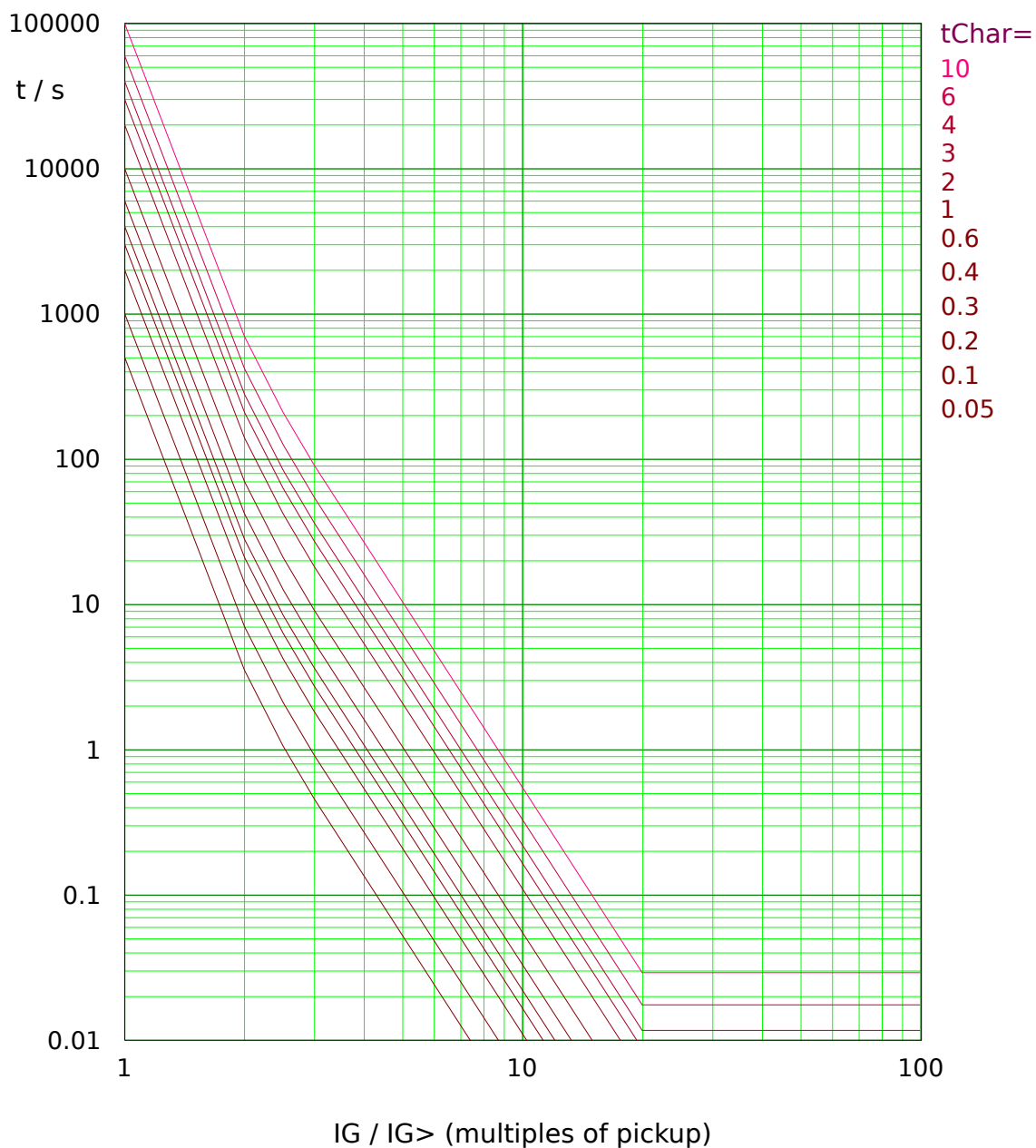

Fig. 113: FR Fuse: trip delay, $I_G > I_{G>}$, example for $I_{Dyn.Lim.} = 20 \cdot I_{G>}$.

See ↪“Explanation for All Characteristics ($I_{G>}$, $I_{G>>}$)” and ↪12.2.2.2 Inverse-Time Characteristics ($I_{G>}$, $I_{G>>}$) for details.

Reset Delay

The reset modes “instantaneous” or “definite time” are available. For this characteristic, there is no reset mode with dynamic reset delay.

Trip Delay

If $I_{G>} < IG < I_{Dyn.Lim.}$, the trip delay is defined [by the characteristic](#).

For $IG > I_{Dyn.Lim.}$, the trip delay t is kept constant at $t = t_{Dyn.Lim.}$.

12.2.2.2.5 IEEE C37.112 Curves (IG>, IG>>)

12.2.2.2.5.1 Moderately Inverse [MINV] - Characteristic (IEEE C37.112)

»Char« = "IEEE MINV"

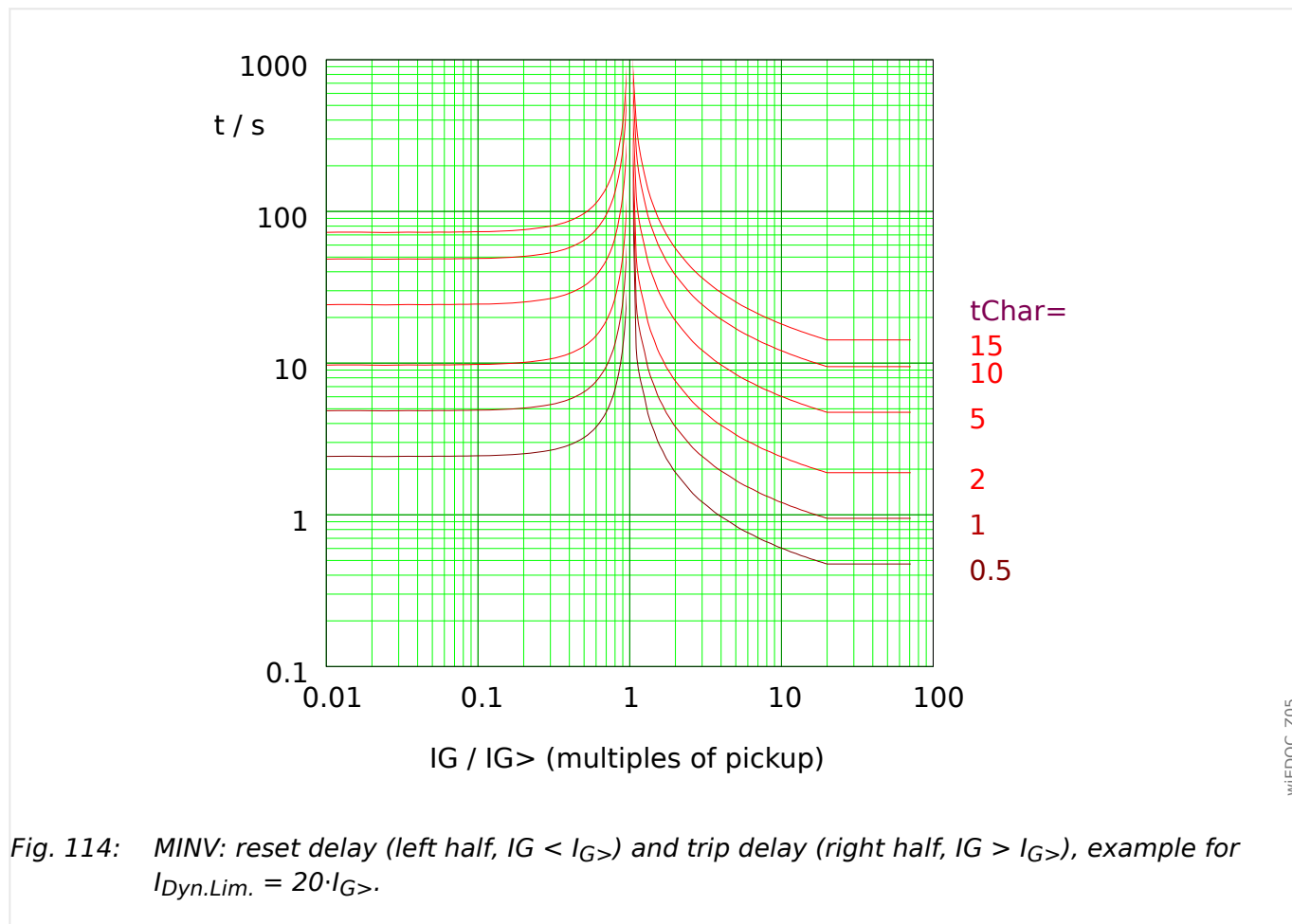

See ↪“Explanation for All Characteristics (IG>, IG>>)” and ↪12.2.2.2 Inverse-Time Characteristics (IG>, IG>>) for details.

Reset Delay

Various reset modes are available: Resetting [via characteristic](#), delayed and instantaneous.

Trip Delay

If $I_{G>} < I_G < I_{Dyn.Lim.}$, the trip delay is defined [by the characteristic](#).

For $I_G > I_{Dyn.Lim.}$, the trip delay t is kept constant at $t = t_{Dyn.Lim.}$.

»Char« = "IEEE VINV"

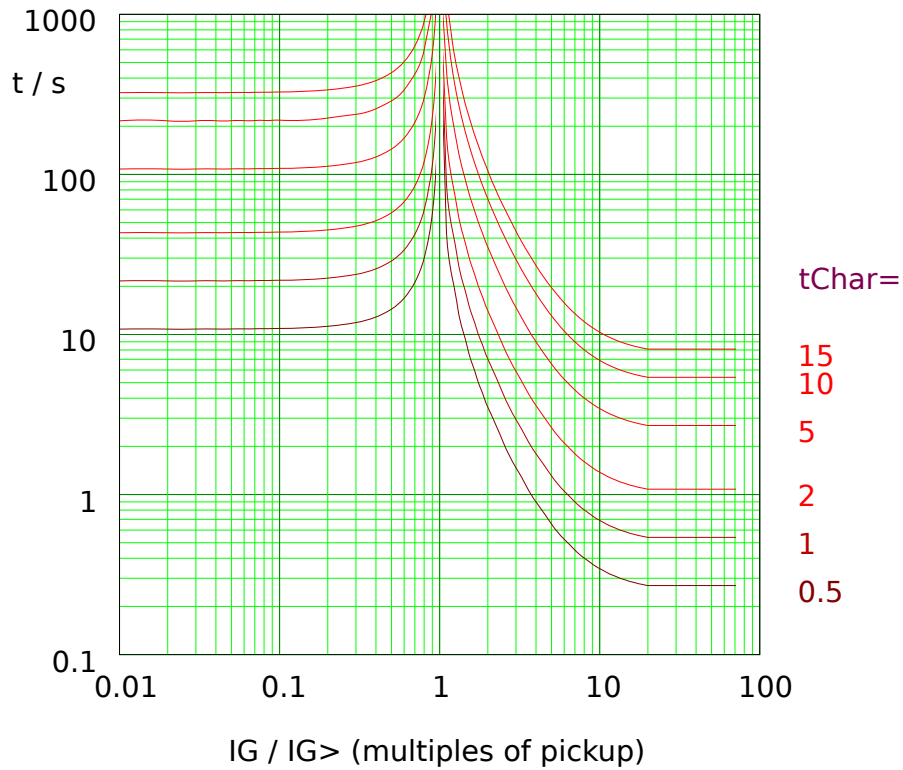

Fig. 115: VINV: reset delay (left half, $I_G < I_{G>}$) and trip delay (right half, $I_G > I_{G>}$), example for $I_{Dyn.Lim.} = 20 \cdot I_{G>}$.

See ↪“Explanation for All Characteristics ($I_{G>}$, $I_{G>>}$)” and ↪12.2.2.2 Inverse-Time Characteristics ($I_{G>}$, $I_{G>>}$) for details.

Reset Delay

Various reset modes are available: Resetting [via characteristic](#), delayed and instantaneous.

Trip Delay

If $I_{G>} < I_G < I_{Dyn.Lim.}$, the trip delay is defined [by the characteristic](#).

For $I_G > I_{Dyn.Lim.}$, the trip delay t is kept constant at $t = t_{Dyn.Lim.}$.

12.2.2.2.5.3 Extremely Inverse - Characteristic (IEEE C37.112)

»Char« = "IEEE EINV"

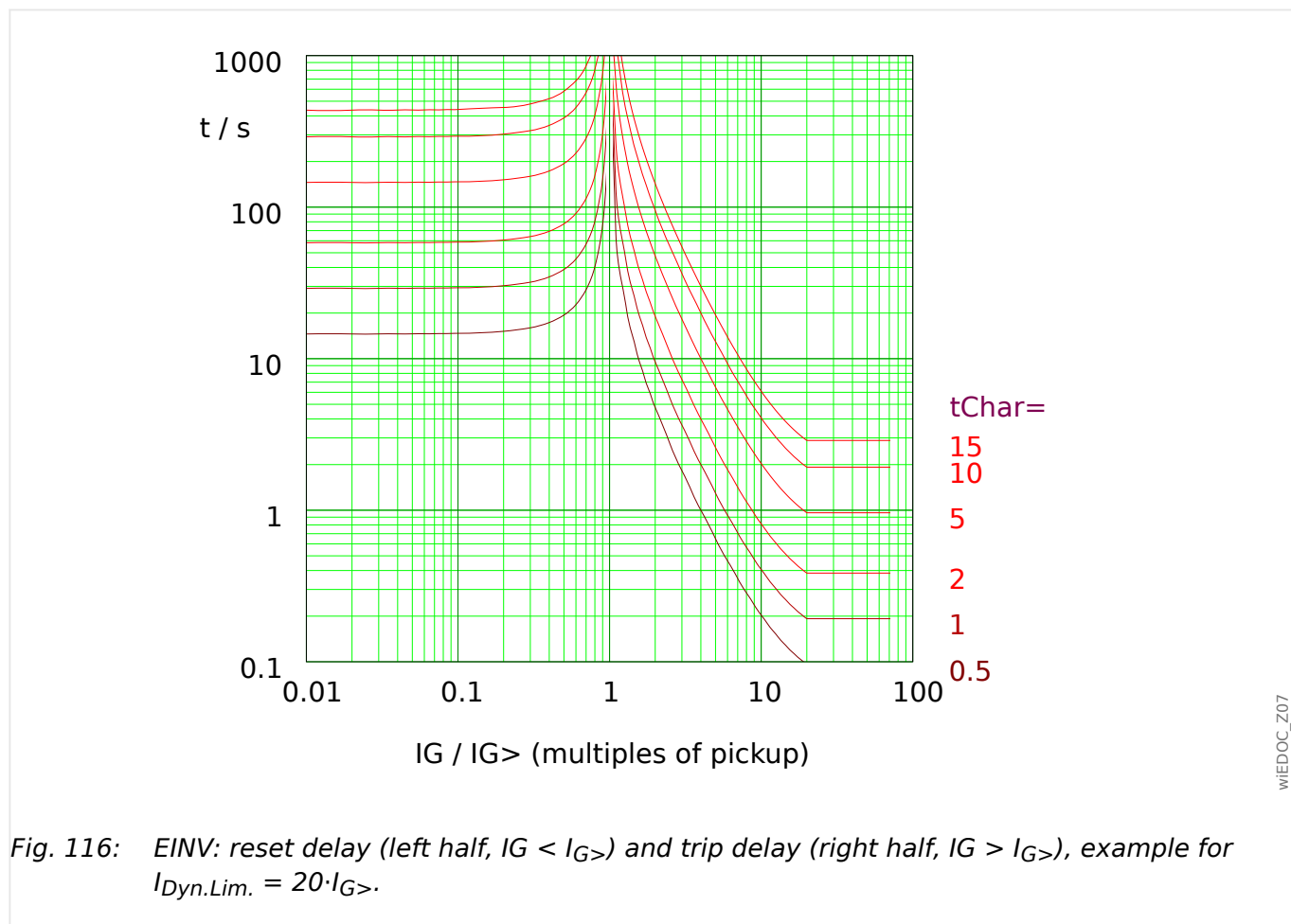

See ↪“Explanation for All Characteristics ($I_{G>}$, $I_{G>>}$)” and ↪12.2.2.2 Inverse-Time Characteristics ($I_{G>}$, $I_{G>>}$) for details.

Reset Delay

Various reset modes are available: Resetting [via characteristic](#), delayed and instantaneous.

Trip Delay

If $I_{G>} < I_G < I_{Dyn.Lim.}$, the trip delay is defined [by the characteristic](#).

For $I_G > I_{Dyn.Lim.}$, the trip delay t is kept constant at $t = t_{Dyn.Lim.}$.

12.2.2.2.6 “EF” Curve

»Char« = EF Curve

See [↪“Explanation for All Characteristics \(IG>, IG>>\)”](#) for details.

Reset Delay

The reset modes “instantaneous” or “definite time” are available. For this characteristic, there is no reset mode with dynamic reset delay.

Trip Delay

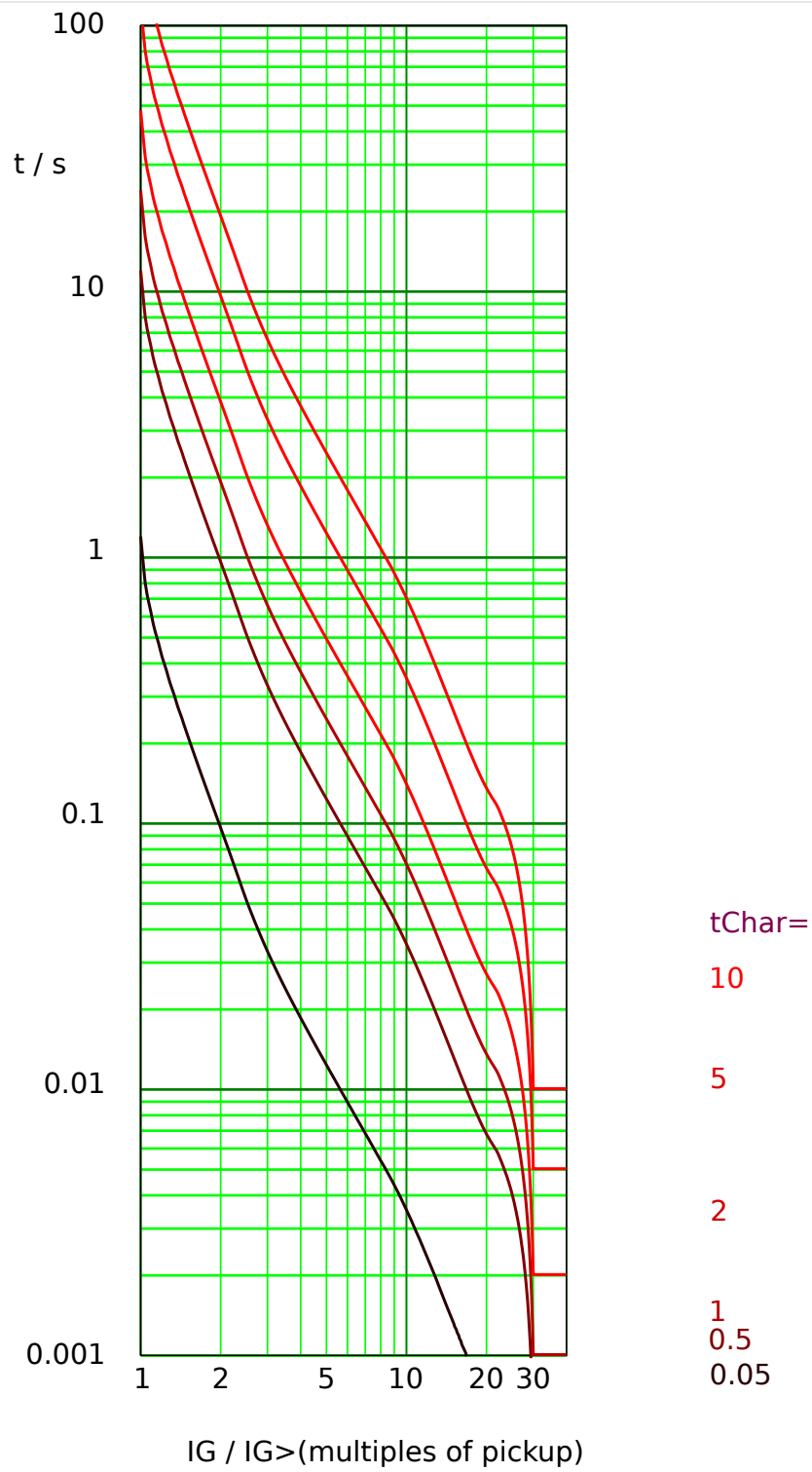
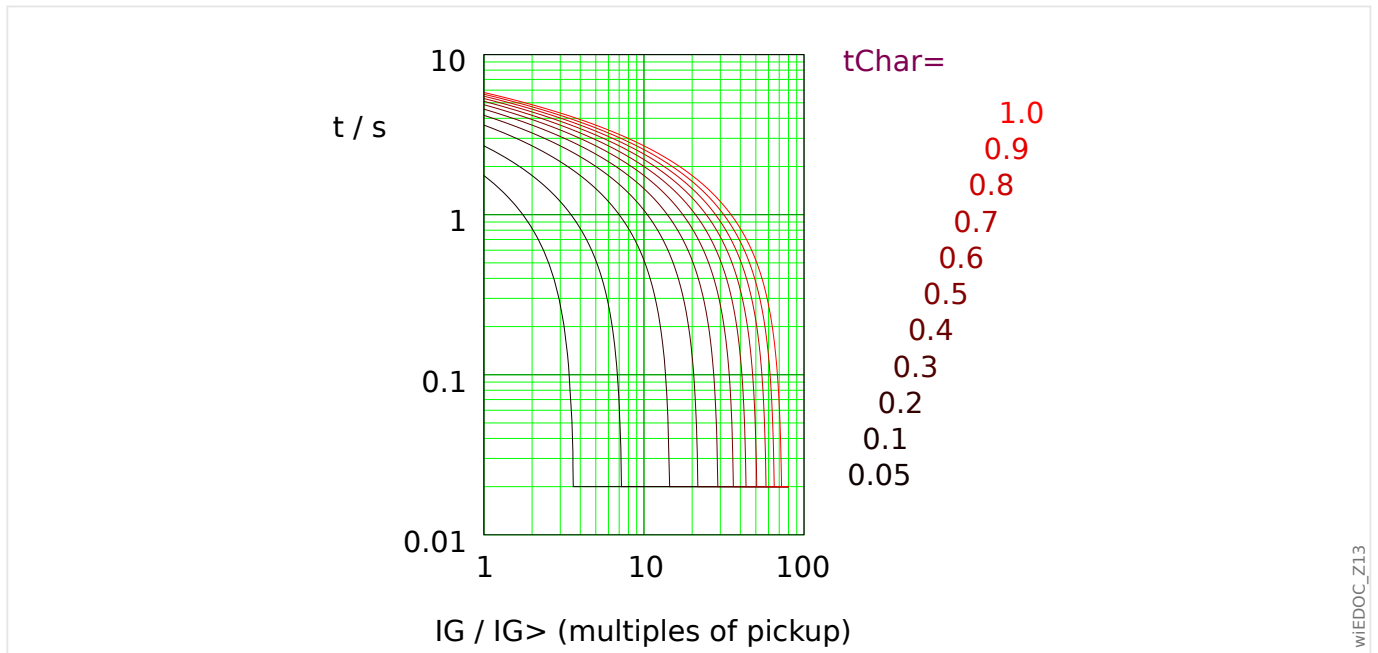

Fig. 117: EF Curve: trip delay, $I_G > I_{G>}$, example for $I_{Dyn.Lim.} = 30 \cdot I_{G>}$.

wIEDOC_Z16

12.2.2.2.7 RXIDG

»Char« = RXIDG



WIEDOC_Z13

Fig. 118: RXIDG: trip delay, $I_G > I_{G>}$.

See ↔“Explanation for All Characteristics ($I_G >$, $I_{G> >}$)” and ↔12.2.2.2 Inverse-Time Characteristics ($I_G >$, $I_{G> >}$) for details.

Reset Delay

The reset modes “instantaneous” or “definite time” are available. For this characteristic, there is no reset mode with dynamic reset delay.

Trip Delay

If $I_G > < I_G$, the trip delay is defined by this equation, but only under the condition that the resulting trip delay holds $t > t_{Dyn.Lim.}$ with $t_{Dyn.Lim.} = 0.02$ s.

In other words, the trip delay t is always at least $t_{Dyn.Lim.} = 0.02$ s.

12.2.3 Characteristics »I2>«

The following characteristics are available with the protection stage »I2>«:

- **DEFT** - *Definite Time-Overcurrent*
- **IEC 60255-151 Curves:**
 - **NINV** - *IEC Normal Inverse* (IEC 60255-151)
 - **VINV** - *IEC Very Inverse* (IEC 60255-151)
 - **LINV** - *IEC Long Time Inverse* (IEC 60255-151)
 - **EINV** - *IEC Extremely Inverse* (IEC 60255-151)
- **RINV** - *R Inverse*
- **HV Fuse** Fuse Characteristic of an HV Fuse
- **FR Fuse** Fuse Characteristic of a Full Range Fuse
- **Curves Defined in IEEE C37.112:**
 - **MINV** - *IEEE Moderately Inverse* (IEEE C37.112)
 - **VINV** - *IEEE Very Inverse* (IEEE C37.112)
 - **EINV** - *IEEE Extremely Inverse* (IEEE C37.112)
- **EF Curve** "EF" Curve

Explanation for All Characteristics (»I2>«)

- I2: Unbalanced load current
- I> = I2>: Pickup value for the protection stage. If the pickup value is exceeded, the stage starts to time out to trip.
- Setting: [Protection Para / I2>] »I2«
- Trip delay t for I2 > I2>:
 - for »Char« = "DEFT": settable via [Protection Para / I2>] »t«.
 - for all other characteristics: calculated based on the selected curve.
- Reset mode for I2 < I2>, settable via »Reset Mode«, available options:
 - With option »Reset Mode« = "instantaneous": Instantaneous reset: when the current drops below the pickup setting, the TOC time resets to zero within 2 cycles.
 - With option »Reset Mode« = "definite time": The reset delay is settable at »tReset«.
 - With option »Reset Mode« = "inverse time" (only available for IEC and ANSI/IEEE curves): The reset delay is calculated based on the selected characteristics.
- tChar (for all characteristics except "DEFT"):

- Time multiplier/tripping characteristic factor. The setting range depends on the selected tripping curve.
- Setting via [Protection Para / I2>] »tChar«

For all inverse-time characteristics (i. e. all curves except the **DEFT**), there are two minimum trip delays, and independent of the selected characteristic will the actual trip delay never be smaller than any of these two minimum delays.

- »I2> . tMinimum« is a minimum delay settable by the user. So, this is simply a timer that is triggered independent of the inverse-time curve and that has to elapse before the protection stage trips. If it is set to 0 seconds it is deactivated. (See also →5.6.2 [Current Unbalance Protection – Settings via Smart view \(PC\) or DiggiMEC.](#))
- Another minimum delay, $t_{Dyn.Lim.}$, results from a calculated “knee-point” of the characteristic. This means it is dependent on a particular current value on the curve, $I_{Dyn.Lim.}$. The effective trip delay does never fall below $t_{Dyn.Lim.}$, independent of the actual value of I2.
 - $I_{Dyn.Lim.}$ is defined as the smallest value out of $20 \cdot I_n$ and $20 \cdot I_{2>}$ ([EF Curve: 30 · I2>](#)).
 - Then $t_{Dyn.Lim.}$ is the delay time that is calculated from this $I_{Dyn.Lim.}$ based on the selected characteristic.
 - (The diagram of each characteristic curve shows this “knee-point”, assuming the example value $I_{Dyn.Lim.} = 20 \cdot I_{2>}$ [[EF Curve: 30 · I2>](#)].)

12.2.3.1 DEFT - Definite Time-Overcurrent (»I2>«)

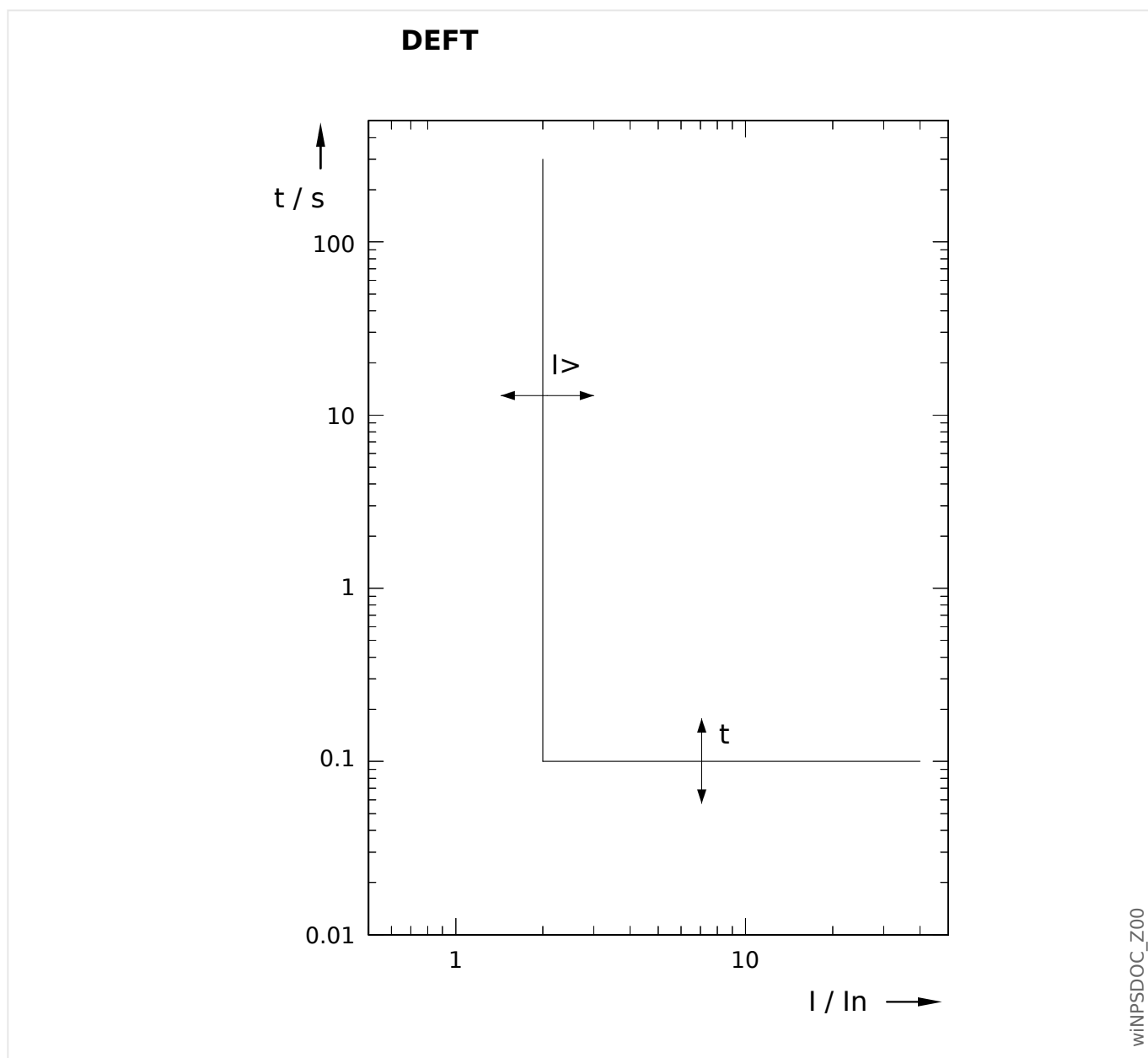

Trip delay for $I_2 > I_{2>}$, settable via [Protection Para / I2>] »t«.

The reset delay for $I_2 < I_{2>}$ always equals 0 ("instantaneous").

12.2.3.2 Inverse-Time Characteristics (»I2>«)

Characteristic »Char«	Trip Delay			Reset Delay (only for »Reset Mode« = "inverse time")	
	$t = \left(\frac{k}{\left(\frac{I2}{I>} \right)^\alpha - 1} + c \right) \cdot tChar$			$t = \frac{\tau}{1 - \left(\frac{I2}{I>} \right)^\alpha} \cdot tChar$	
	k [s]	c [s]	α	τ [s]	α
IEC NINV	0.14	0	0.02	0.14	2
IEC VINV	13.5	0	1	13.5	2
IEC EINV	80	0	2	80	2
IEC LINV	120	0	1	120	2
IEEE MINV	0.0515	0.1140	0.02	4.85	2
IEEE VINV	19.61	0.491	2	21.6	2
IEEE EINV	28.2	0.1217	2	29.1	2

Characteristic »Char«	Trip Delay			Reset Delay (only for »Reset Mode« = "inverse time")	
	$t = \frac{k}{b - \frac{c}{\left(\frac{I2}{I>} \right)}} \cdot tChar$			$t = \frac{\tau}{1 - \left(\frac{I2}{I>} \right)^\alpha} \cdot tChar$	
	k [s]	b	c	τ [s]	α
RINV	1.0	0.339	0.236	1.0	2

Characteristic »Char«		Trip Delay			
		$t = k \cdot t_{Char} \cdot 10^{\alpha \cdot \log(b \cdot \frac{I2}{I2>}) + c}$			
		k [s]	b	c	α
HV Fuse		10	2	3.66	-3.8320
FR Fuse	$1 < \frac{I2}{I2>} < 2$	10	1	3.0	-7.16
	$2 < \frac{I2}{I2>} < 2.66$	10	1	2.47	-5.4
	$2.66 < \frac{I2}{I2>} < \frac{I_{max}}{I2>}$	10	1	1.98	-4.24

See [↔“Explanation for All Characteristics \(»I2>«\)”](#) for more information.

»Char« = IEC NINV

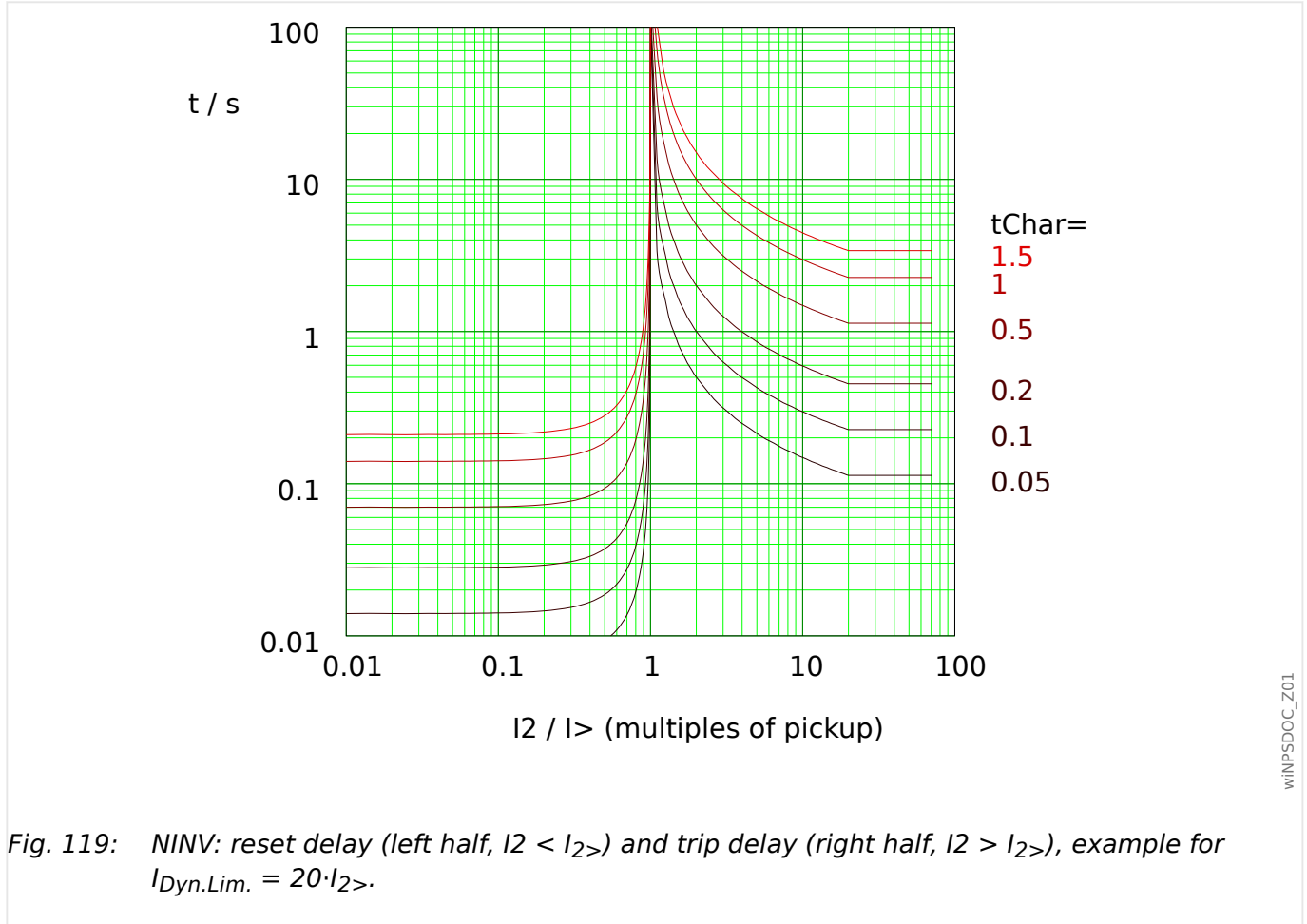

Fig. 119: NINV: reset delay (left half, $I_2 < I_{2>}$) and trip delay (right half, $I_2 > I_{2>}$), example for $I_{Dyn.Lim.} = 20 \cdot I_{2>}$.

See ↪“Explanation for All Characteristics (»I2>«)” and ↪12.2.3.2 Inverse-Time Characteristics (»I2>«) for details.

Reset Delay

Various reset modes are available: Resetting [via characteristic](#), delayed and instantaneous.

Trip Delay

If $I_{2>} < I_2 < I_{Dyn.Lim.}$, the trip delay is defined [by the characteristic](#).

For $I_2 > I_{Dyn.Lim.}$, the trip delay t is kept constant at $t = t_{Dyn.Lim.}$.

12.2.3.2.1.2 Very Inverse [VINV] (IEC 60255-151)

»Char« = IEC VINV

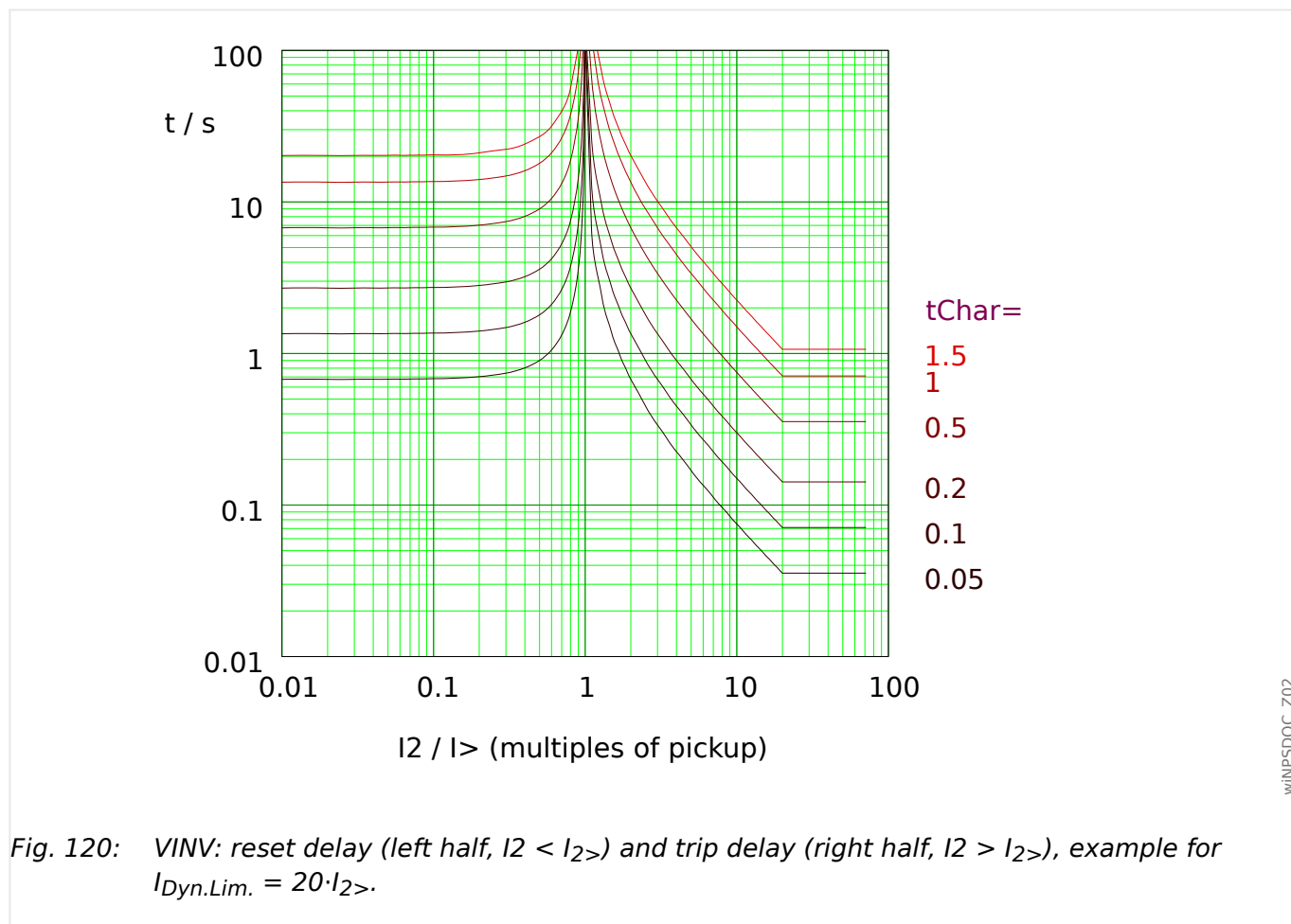

See ↪“Explanation for All Characteristics (»I2>«)” and ↪12.2.3.2 Inverse-Time Characteristics (»I2>«) for details.

Reset Delay

Various reset modes are available: Resetting [via characteristic](#), delayed and instantaneous.

Trip Delay

If $I_2 < I_{2>} < I_{Dyn.Lim.}$, the trip delay is defined [by the characteristic](#).

For $I_2 > I_{Dyn.Lim.}$, the trip delay t is kept constant at $t = t_{Dyn.Lim.}$.

»Char« = IEC EINV

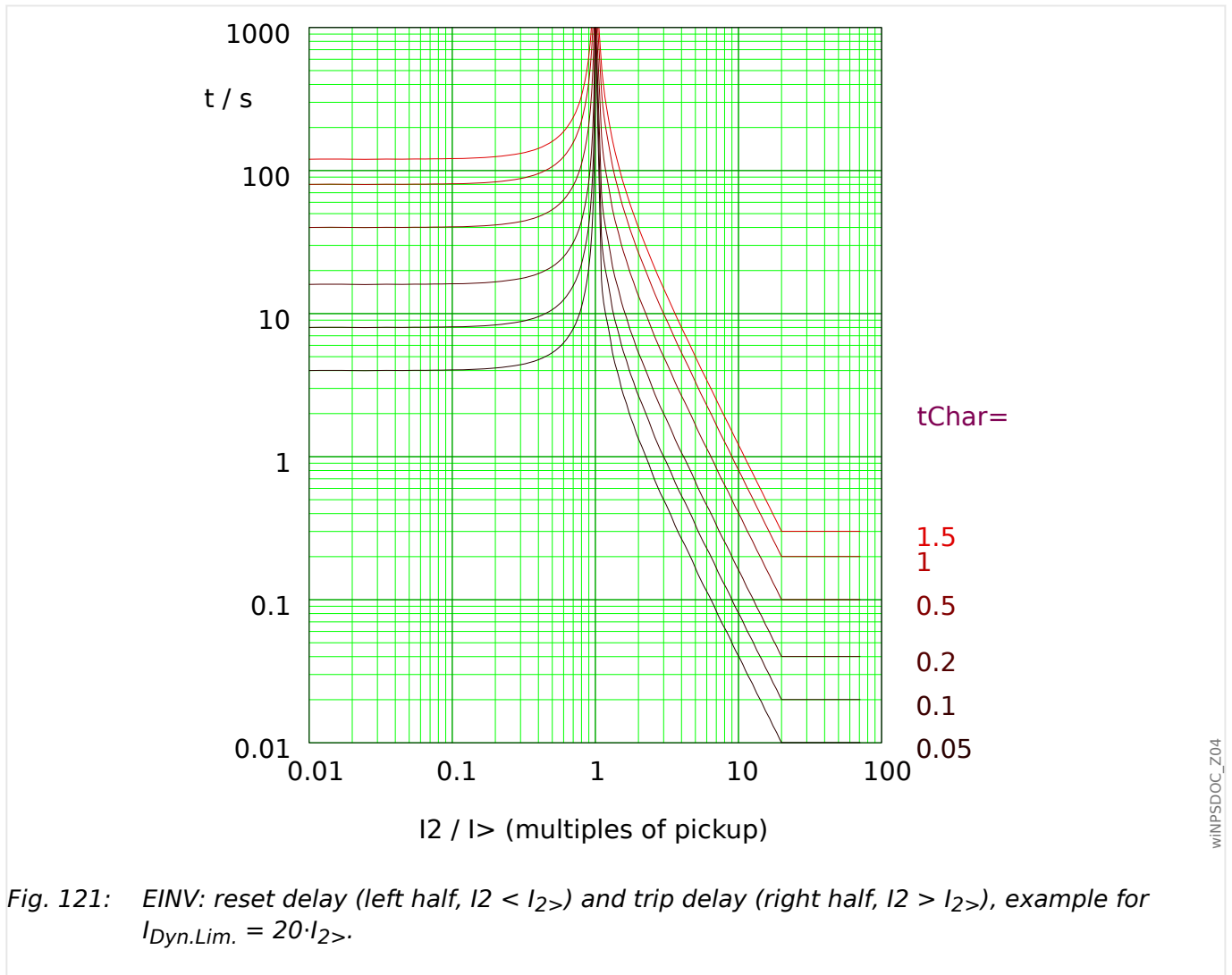

Fig. 121: EINV: reset delay (left half, $I_2 < I_{2>}$) and trip delay (right half, $I_2 > I_{2>}$), example for $I_{Dyn.Lim.} = 20 \cdot I_{2>}$.

See ↪“Explanation for All Characteristics (»I2>«)” and ↪12.2.3.2 Inverse-Time Characteristics (»I2>«) for details.

Reset Delay

Various reset modes are available: Resetting [via characteristic](#), delayed and instantaneous.

Trip Delay

If $I_{2>} < I_2 < I_{Dyn.Lim.}$, the trip delay is defined [by the characteristic](#).

For $I_2 > I_{Dyn.Lim.}$, the trip delay t is kept constant at $t = t_{Dyn.Lim.}$.

12.2.3.2.1.4 Long Time Inverse - Characteristic [LINV] (IEC 60255-151)

»Char« = IEC LINV

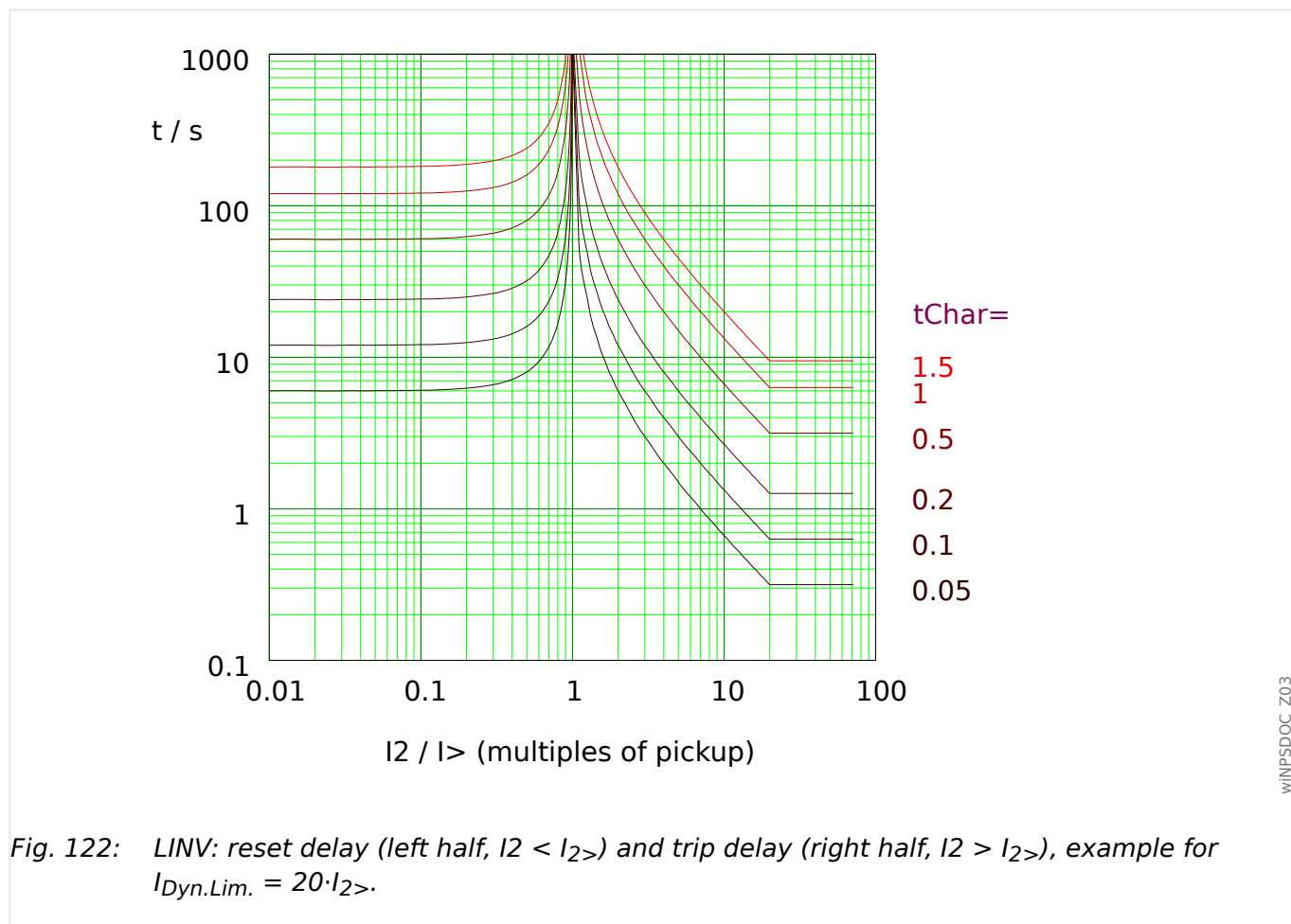

Fig. 122: LINV: reset delay (left half, $I_2 < I_{2>}$) and trip delay (right half, $I_2 > I_{2>}$), example for $I_{Dyn.Lim.} = 20 \cdot I_{2>}$.

See ↪“Explanation for All Characteristics (»I2>«)” and ↪12.2.3.2 Inverse-Time Characteristics (»I2>«) for details.

Reset Delay

Various reset modes are available: Resetting [via characteristic](#), delayed and instantaneous.

Trip Delay

If $I_2 < I_{2>} < I_{Dyn.Lim.}$, the trip delay is defined [by the characteristic](#).

For $I_2 > I_{Dyn.Lim.}$, the trip delay t is kept constant at $t = t_{Dyn.Lim.}$.

12.2.3.2.2 R Inverse [RINV] - Characteristic

»Char« = RINV

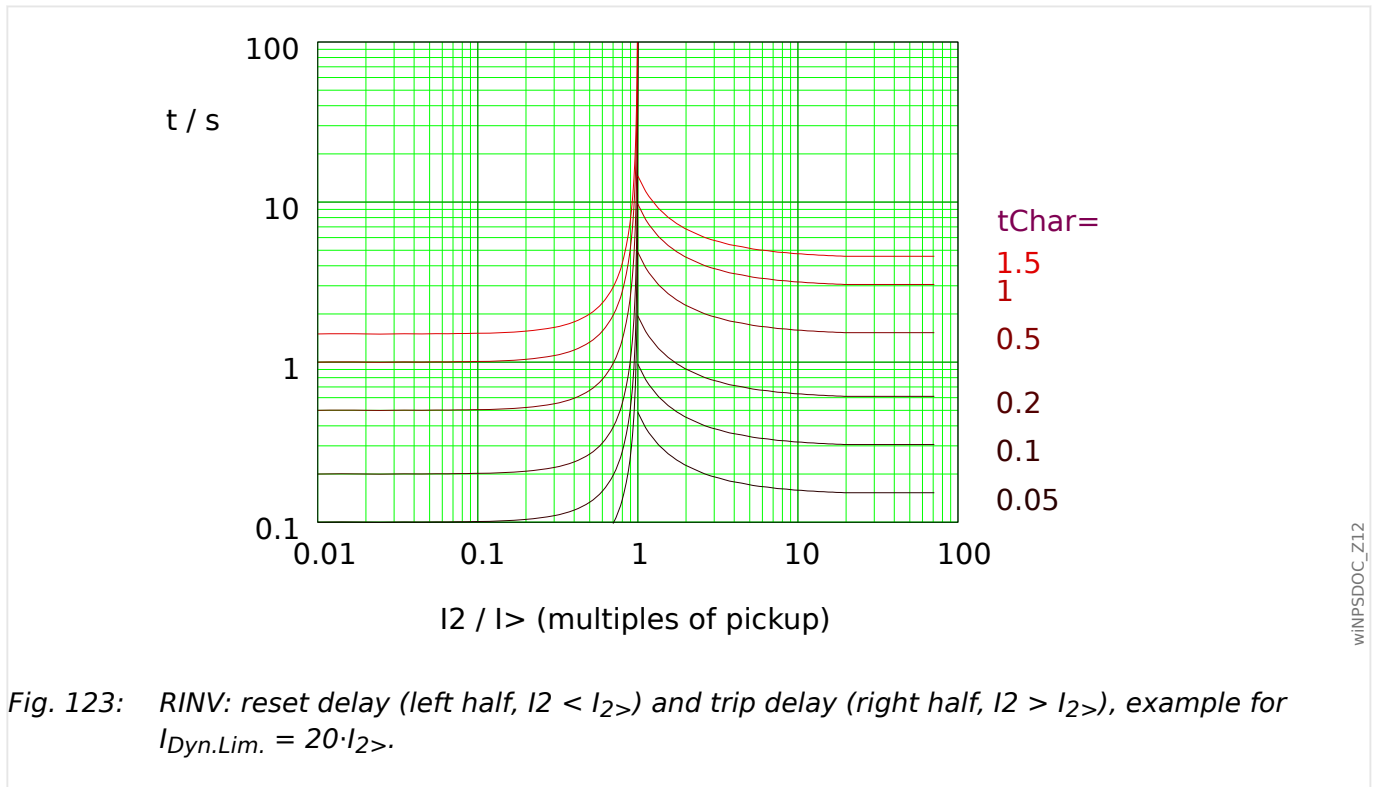

Fig. 123: RINV: reset delay (left half, $I_2 < I_{2>}$) and trip delay (right half, $I_2 > I_{2>}$), example for $I_{Dyn.Lim.} = 20 \cdot I_{2>}$.

See ↪“Explanation for All Characteristics (»I2>«)” and ↪12.2.3.2 Inverse-Time Characteristics (»I2>«) for details.

Reset Delay

Various reset modes are available: Resetting [via characteristic](#), delayed and instantaneous.

Trip Delay

If $I_{2>} < I_2 < I_{Dyn.Lim.}$, the trip delay is defined [by the characteristic](#).

For $I_2 > I_{Dyn.Lim.}$, the trip delay t is kept constant at $t = t_{Dyn.Lim.}$.

12.2.3.2.3 Fuse Characteristic of an HV Fuse

»Char« = HV Fuse

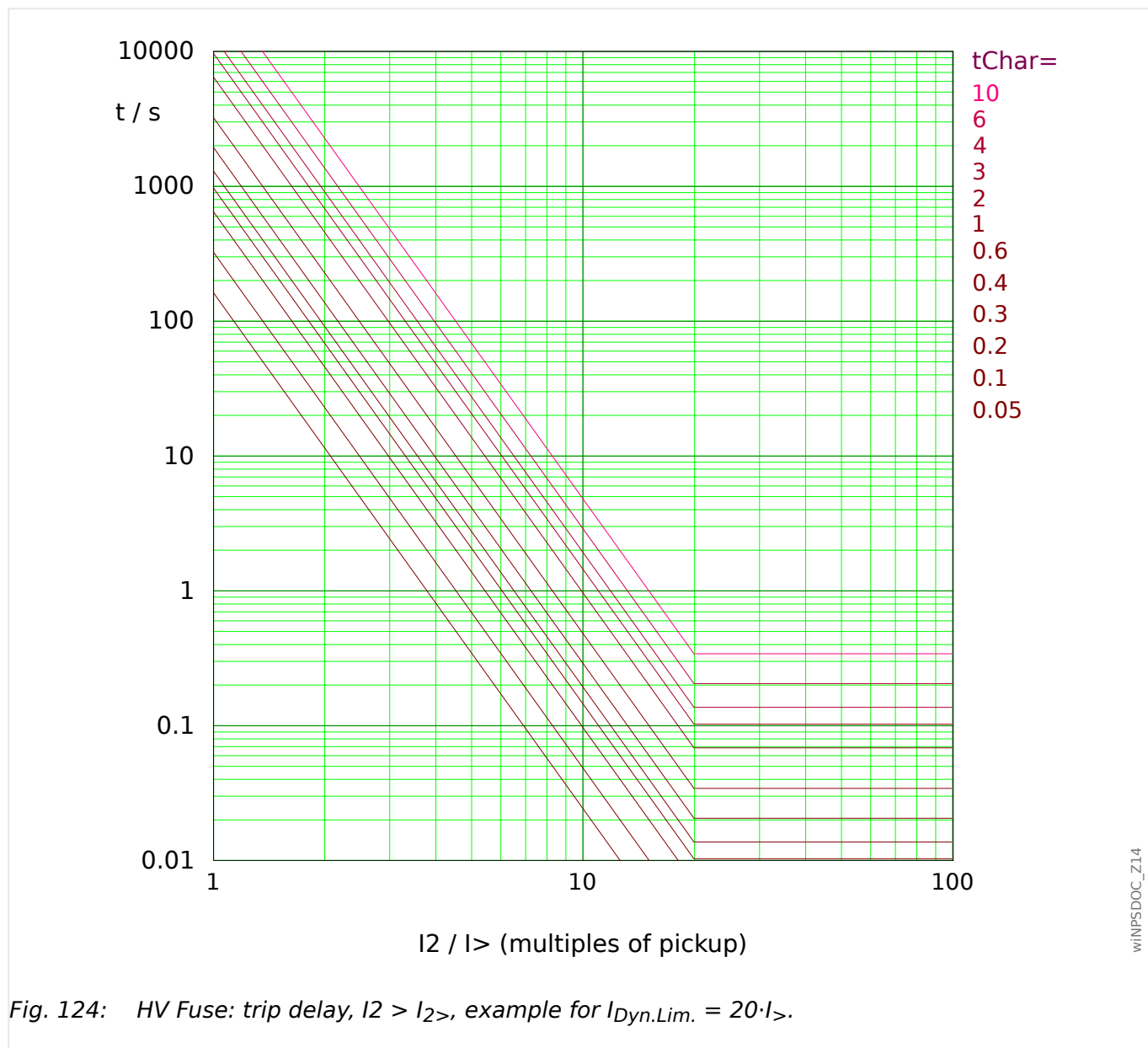

Fig. 124: HV Fuse: trip delay, $I_2 > I_{2>}$, example for $I_{Dyn.Lim.} = 20 \cdot I_{2>}$.

See ↪“Explanation for All Characteristics (»I2>«)” and ↪12.2.3.2 Inverse-Time Characteristics (»I2>«) for details.

Reset Delay

The reset modes “instantaneous” or “definite time” are available. For this characteristic, there is no reset mode with dynamic reset delay.

Trip Delay

If $I_2 < I_{2>} < I_{Dyn.Lim.}$, the trip delay is defined by the characteristic.

For $I_2 > I_{Dyn.Lim.}$, the trip delay t is kept constant at $t = t_{Dyn.Lim.}$.

12.2.3.2.4 Fuse Characteristic of a Full Range Fuse (FR-Fuse)

»Char« = FR Fuse

Remark: This characteristic is sometimes also called the “Sweden curve”.

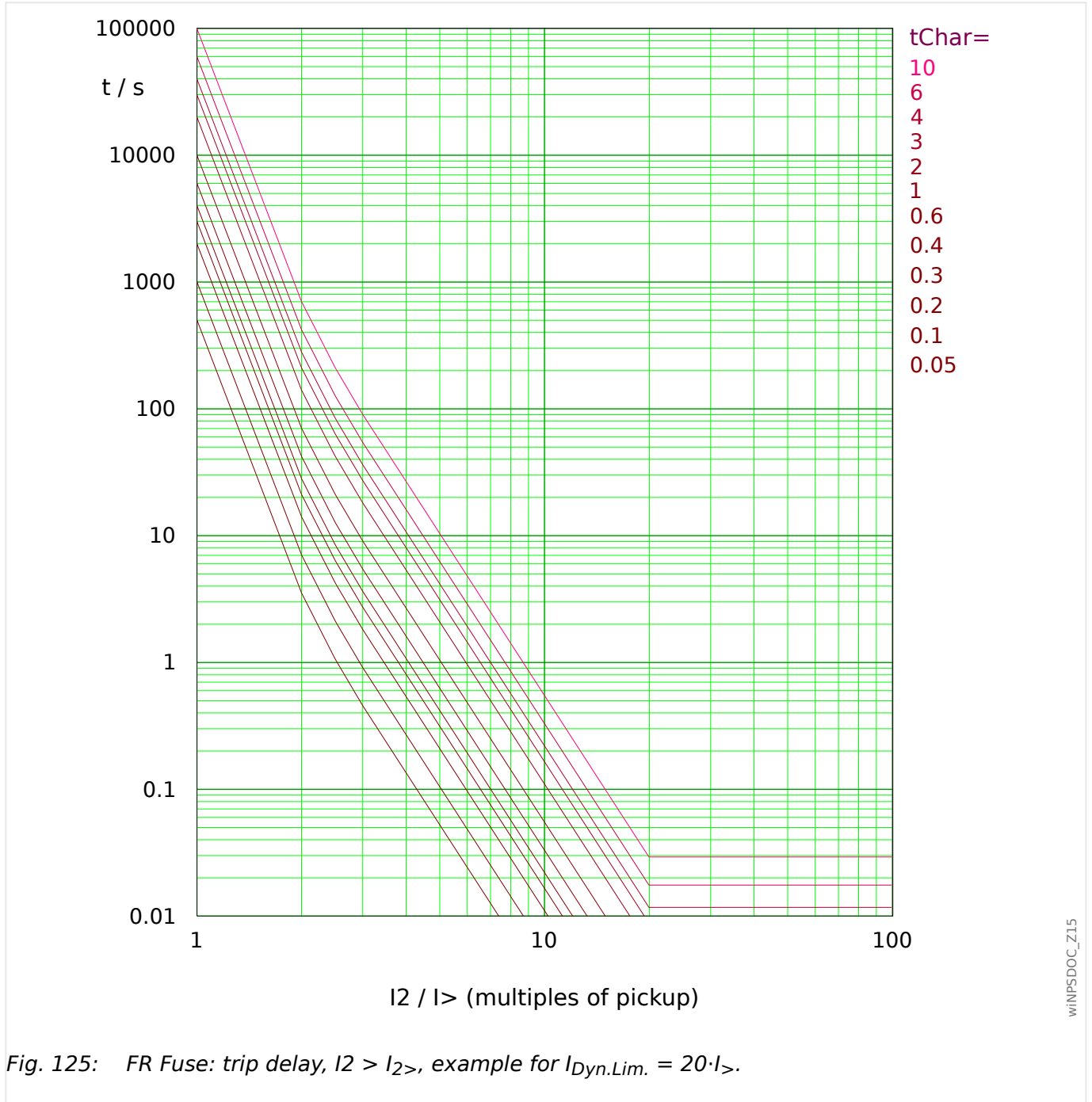

Fig. 125: FR Fuse: trip delay, $I_2 > I_{2>}$, example for $I_{Dyn.Lim.} = 20 \cdot I_{>}$.

See ↪“Explanation for All Characteristics (»I2>«)” and ↪12.2.3.2 Inverse-Time Characteristics (»I2>«) for details.

Reset Delay

The reset modes “instantaneous” or “definite time” are available. For this characteristic, there is no reset mode with dynamic reset delay.

Trip Delay

If $I_2 < I_2 < I_{Dyn.Lim.}$, the trip delay is defined by the characteristic.

For $I_2 > I_{Dyn.Lim.}$, the trip delay t is kept constant at $t = t_{Dyn.Lim.}$.

12.2.3.2.5 IEEE C37.112 Curves (»I2>«)

12.2.3.2.5.1 Moderately Inverse [MINV] - Characteristic (IEEE C37.112)

»Char« = "IEEE MINV"

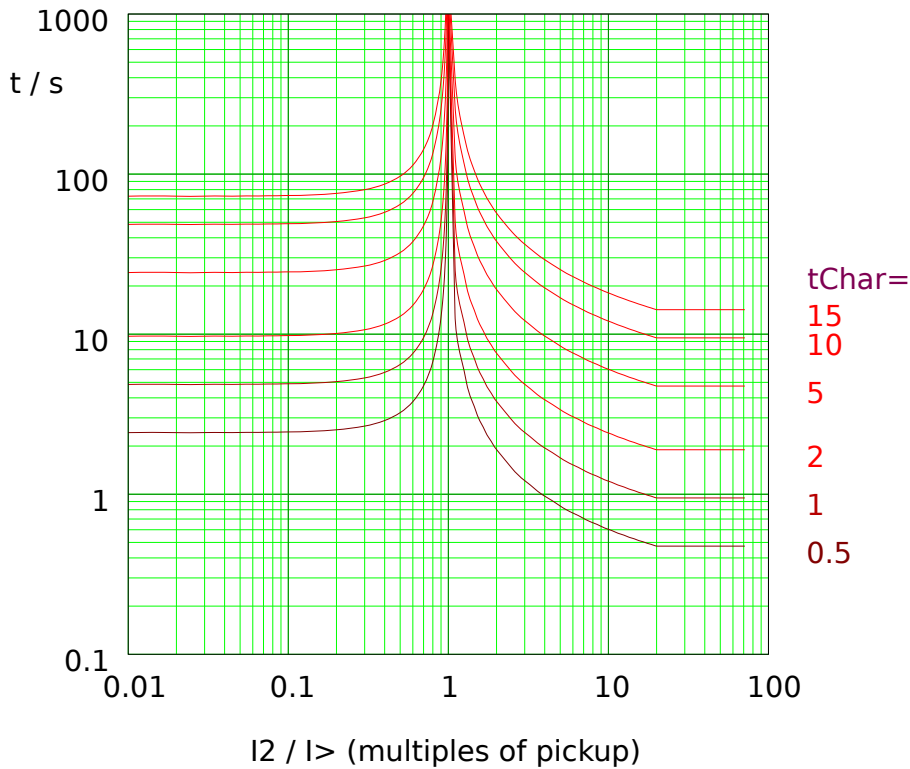

Fig. 126: MINV: reset delay (left half, $I_2 < I_{2>}$) and trip delay (right half, $I_2 > I_{2>}$), example for $I_{Dyn.Lim.} = 20 \cdot I_{2>}$.

See ↪“Explanation for All Characteristics (»I2>«)” and ↪12.2.3.2 Inverse-Time Characteristics (»I2>«) for details.

Reset Delay

Various reset modes are available: Resetting [via characteristic](#), delayed and instantaneous.

Trip Delay

If $I_{2>} < I_2 < I_{Dyn.Lim.}$, the trip delay is defined [by the characteristic](#).

For $I_2 > I_{Dyn.Lim.}$, the trip delay t is kept constant at $t = t_{Dyn.Lim.}$.

12.2.3.2.5.2 Very Inverse [VINV] (IEEE C37.112)

»Char« = "IEEE VINV"

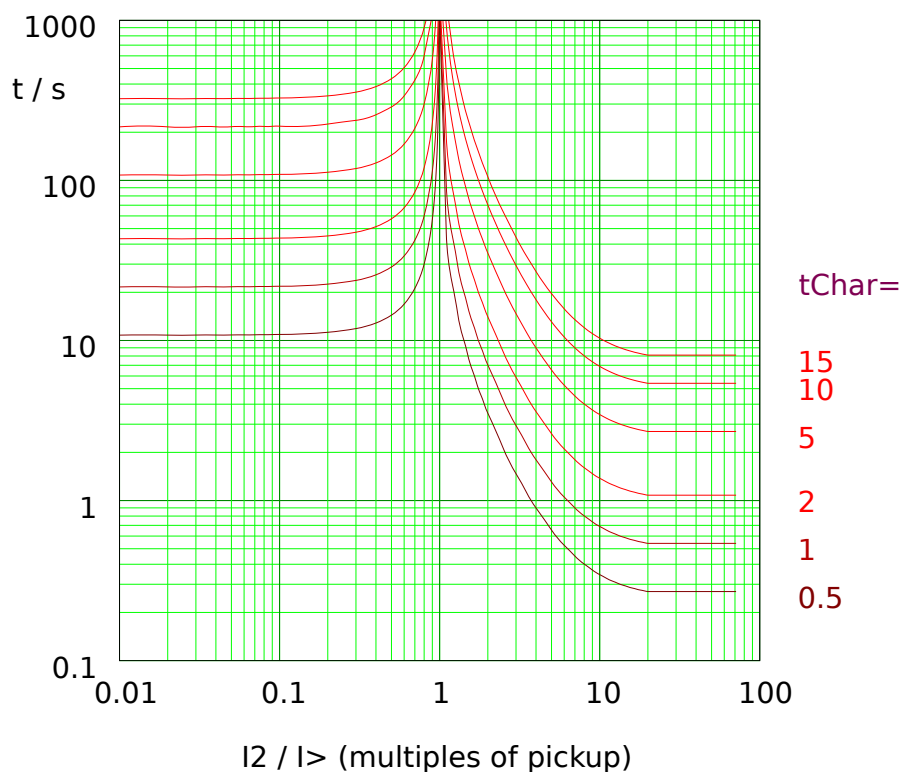

Fig. 127: VINV: reset delay (left half, $I_2 < I_{2>}$) and trip delay (right half, $I_2 > I_{2>}$), example for $I_{Dyn.Lim.} = 20 \cdot I_{2>}$.

See ↪“Explanation for All Characteristics (»I2>«)” and ↪12.2.3.2 Inverse-Time Characteristics (»I2>«) for details.

Reset Delay

Various reset modes are available: Resetting [via characteristic](#), delayed and instantaneous.

Trip Delay

If $I_{2>} < I_2 < I_{Dyn.Lim.}$, the trip delay is defined [by the characteristic](#).

For $I_2 > I_{Dyn.Lim.}$, the trip delay t is kept constant at $t = t_{Dyn.Lim.}$.

»Char« = "IEEE EINV"

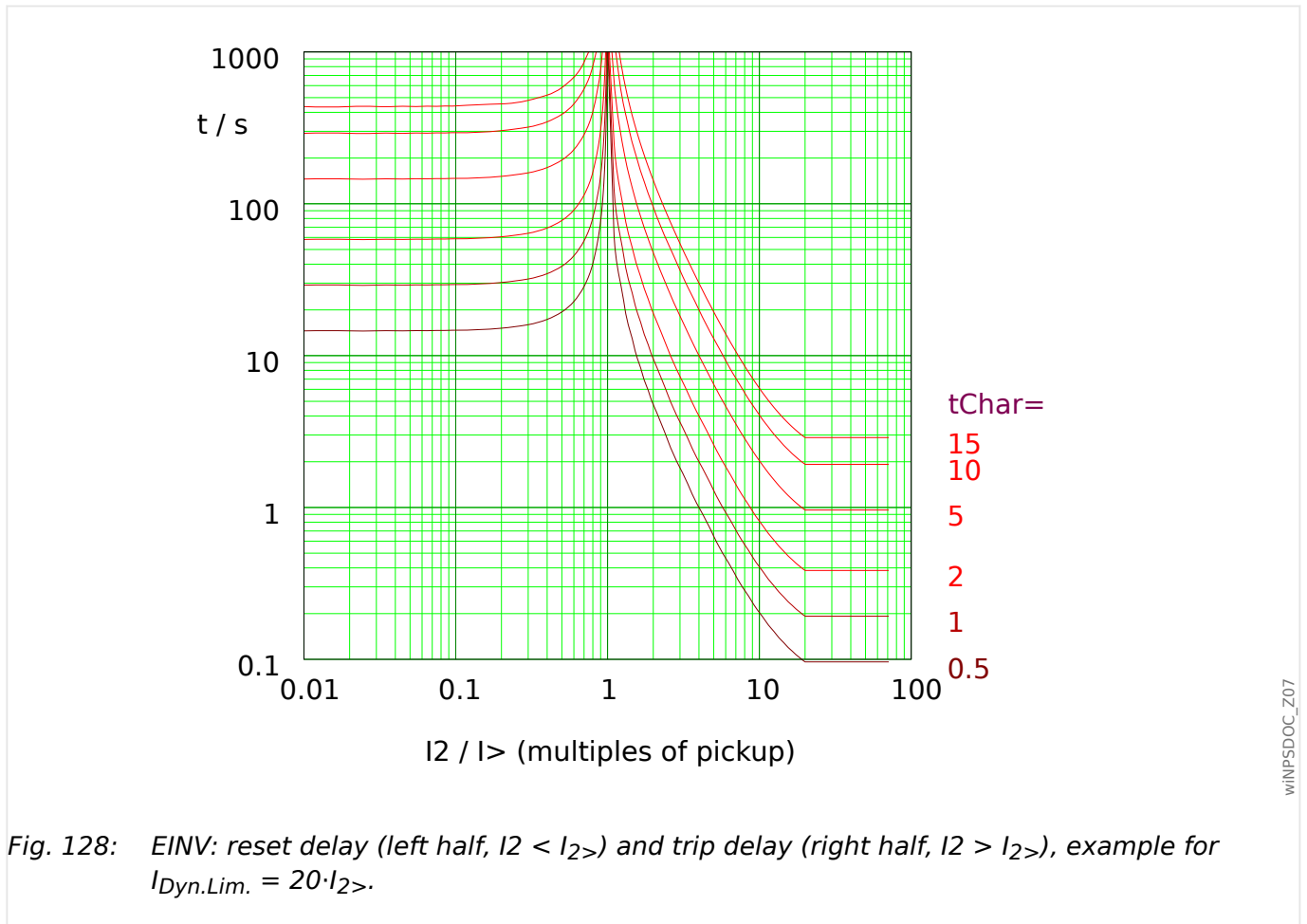

Fig. 128: EINV: reset delay (left half, $I_2 < I_{2>}$) and trip delay (right half, $I_2 > I_{2>}$), example for $I_{Dyn.Lim.} = 20 \cdot I_{2>}$.

See ↪“Explanation for All Characteristics (»I2>«)” and ↪12.2.3.2 Inverse-Time Characteristics (»I2>«) for details.

Reset Delay

Various reset modes are available: Resetting [via characteristic](#), delayed and instantaneous.

Trip Delay

If $I_{2>} < I_2 < I_{Dyn.Lim.}$, the trip delay is defined [by the characteristic](#).

For $I_2 > I_{Dyn.Lim.}$, the trip delay t is kept constant at $t = t_{Dyn.Lim.}$.

12.2.3.2.6 "EF" Curve

»Char« = EF Curve

Reset Delay

The reset modes "instantaneous" or "definite time" are available. For this characteristic, there is no reset mode with dynamic reset delay.

Trip Delay

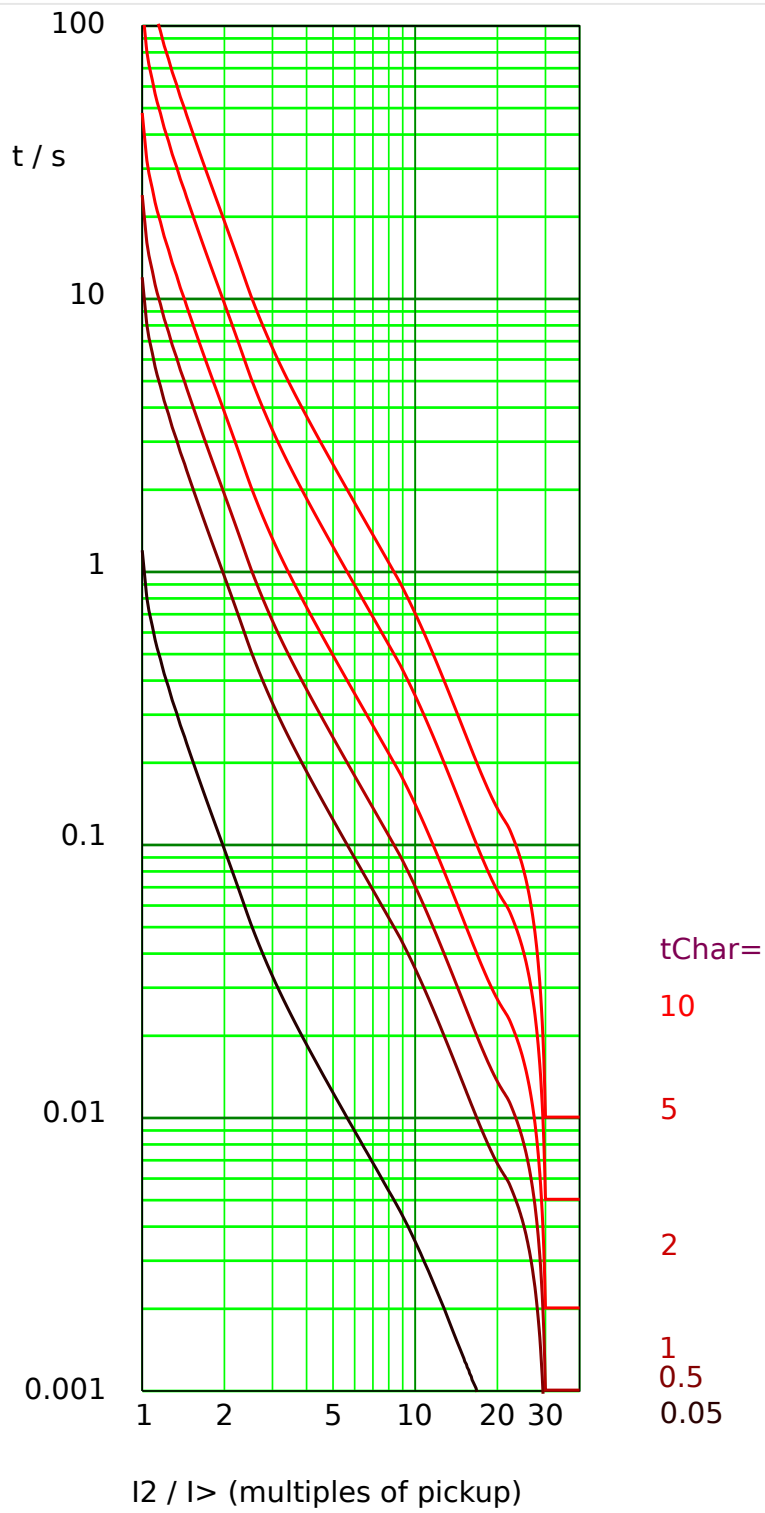

Fig. 129: EF Curve: trip delay, $I_2 > I_{2>}$, example for $I_{Dyn.Lim.} = 30 \cdot I_{2>}$.

See ↪ "Explanation for All Characteristics (»I2>«)" for details.

wiNPSDOC_Z16

12.3 Requirements for 1 A/5 A Standard CTs with WIC1-WC Converter CTs

WARNING!



In addition to the considerations in this chapter and the requirements mentioned, all applicable national and international standards and regulations have to be followed.

There is simplified version of the CT requirements available under [↪3.3.2.1 Requirements for Standard CTs](#). It covers the most common applications and can be used as an alternative in these cases.

Symbols

The following table gives an overview of the symbols that are used in the CT requirement section.

I_{pr}	Primary rated current of the standard CT
I_{sr}	Secondary rated current of the standard CT
R_{ct}	Secondary internal wiring resistance of the standard CT
R_b	Rated resistive burden of the standard CT
R_{wic1}	Impedance of the Converter CT plus WIC1
R_{add}	Additional resistance in the secondary circuit of the standard CT. This includes additional wiring (but without the built-in cables of the Converter CTs), short-circuit rails, etc.
ALF	Accuracy limit factor of the standard CT
E_k	Rated knee point e.m.f. of the standard CT
V_s	Secondary terminal voltage of the standard CT

When dimensioning the standard current transformers, the following minimum conditions must be fulfilled:

Minimum Requirement: Make sure that an Overcurrent Causes a Trip

CT class	Minimum Requirement
P, PR	$ALF \geq 20 \cdot \frac{R_{ct} + R_{add} + R_{wic1}}{R_{ct} + R_b}$
PX, PXR	$E_k \geq \frac{20}{1.2} \cdot I_{sr} \cdot (R_{ct} + R_{add} + R_{wic1})$
IEEE / ANSI C-class	$V_s \geq 20 \cdot I_{sr} \cdot (R_{ct} + R_{add} + R_{wic1})$

	R_{wic1} [Ω] (Normal Connection)	R_{wic1} [Ω] (Holmgreen Connection)
WIC1-WC1-1A	0.2 Ω	0.3 Ω
WIC1-WC1-5A	0.3 Ω	Holmgreen not possible ^(*)
WIC1-WC2-1A	1.4 Ω	1.5 Ω

(*) Holmgreen is not possible with 5 A Standard CTs because the WIC1 does not have a 5 A ground current input.

The maximum permitted short-circuit current of the Converter CTs is 100 In for 1 second. (See the [Technical Data](#).) If the fault current of your application is higher than this please contact our Support team; under some circumstances this can be tolerable.

Example Calculation for a P/PR Class CT

Standard CT, 1 A	$I_{pr} = 25 \text{ A}$ $I_{sr} = 1 \text{ A}$ $R_{ct} = 1.5 \text{ Ω}$
Maximum primary short-circuit current	$I_{psc,max} = 4.0 \text{ kA}$
Rated resistive burden	$R_b = \frac{2.5 \text{ VA}}{(1 \text{ A})^2} = 2.5 \text{ Ω}$
Burden of short-circuit rail in the secondary circuit of the standard CT	$R_{add} = 2.0 \text{ Ω}$
WIC1-WC1-1A Converter CT	$R_{wic1} = 0.2 \text{ Ω}$

This example assumes a [normal connection](#) (i. e. no [Holmgreen](#)) for the standard CTs.

Calculation of the minimum requirement:

$$ALF \geq 20 \cdot \frac{R_{ct} + R_{add} + R_{wic1}}{R_{ct} + R_b} = 20 \cdot \frac{1.5 \text{ Ω} + 2.0 \text{ Ω} + 0.2 \text{ Ω}}{1.5 \text{ Ω} + 2.5 \text{ Ω}} = 18.5$$

The ALF of the standard CT must be greater than 18.5. A 5P20 CT would be sufficient for the given application.

12.4 Revision History

This chapter lists all WIC1 changes since version 1.0.

Out-of-Date Documentation?



This publication may have been revised or updated since this copy was produced. To verify that you have the latest revision, please visit the download section of our website:

- **<https://docs.SEGelectronics.de/wic1>**

Please check this download area for the latest revision of this Technical Manual and whether there is an Errata Sheet with updated information. (The ID of every document is printed on its cover page.)

12.4.1 Version: 2.3

- Date: 2026-April-1

Software

Modbus RTU & TCP: Add support for parameter reading.

DiggiMEC LEDs & flag indicators / output relays: The WIC1 is now pre-configured for a DiggiMEC by default. Therefore, the **LEDs** and **flag indicators / output relays** of the DiggiMECs can be used in a default configuration even in combination with DIP- or HEX-switch parametrization (WIC1-2, WIC1-3).

Trip Coil Output "TC" (Impulse Output): The internal control algorithm for trip pulse generation has been optimised to make the output more robust against incorrect wiring and short-circuits.

Fixes

Incorrect current measurements on phase L3

- Due to the microcontroller's specific behavior, which occurs in very rare cases, there may be occasional deviations in the A/D converter configuration. On occurrence, the measured current in phase L3 (50/60 Hz fundamental/rms values) show a significant overshoot for one 50/60 Hz period before reaching the steady-state value of zero. This condition persists for as long as the device is powered. Possible consequences are unwanted operation of protection or failure to operate.
- According to the proposed measures of the microcontroller manufacturer, a software fix has been implemented which identifies the misconfiguration of the A/D converter in these cases and corrects it immediately. The underlying issue affecting the device's (protection) functionality is then fully resolved.
- For more details see the Service Bulletin CAC_SEG_0170.

12.4.2 Version: 2.2

- Build Versions: 63978, 64078, 64196, 66885
- Date: 2025-May-26

Hardware

[Order Code](#) - additional options:

- **CT Type, DIP/HEX Range:**

- "D" - WC2 Converter CTs, DIP/HEX Range 2

New device variant compatible to [WIC1-WC2 Converter CTs](#) for more sensitive threshold settings for Overcurrent Protection. For DIP/HEX devices the [DIP/HEX layout](#) is altered accordingly.

- **Ground Current Method:**

- "B" - Configurable (Calc. Ground Current default)

The ground (earth) current measurement is switchable between calculated (default setting) and measured for this device variant. The setting is switchable via Smart view (PC) / DiggiMEC (but not via DIP/HEX switches).

WIC1-1 / WIC1-2 / WIC1-3 only.

- **Backup Protection / Self-Supervision:**

- "0" - Self-Supervision operates "FI"-Output

This variant features a [self-supervision function](#) which indicates a permanent device-internal problem at the flag indicator ("FI") output of the WIC1 instead of tripping of a circuit breaker connected to the trip coil ("TC") output.

Additionally, the [Trip Circuit Monitoring \(TCM\)](#) alarm can be assigned to the "FI".

Introduction of [WIC1-WC2 Converter CTs](#). These CTs enable the connection of 1A Standard CTs to the WIC1 and provide more sensitive threshold settings for Overcurrent Protection compared to the WIC1-WC1 CTs. The WIC1-WC2 CTs require a special [Order Code](#).

Software

[DiggiMEC-0](#): Add software support for DiggiMEC option without bi-stable relays / flag indicators.

[Modbus RTU](#) has two additional baud rates available (WIC1-4 only):

- 57600
- 115200

Names of the phases are changed:

- R2.1 and older: "L1", "L2", "L3"
- R2.2: "A", "B", "C"

[PC4 adapter](#) firmware update: For updates to R2.2 and later releases a PC4 adapter can be used as an alternative to a DiggiMEC.

Trip Coil Output "TC" (Impulse Output): The internal control algorithm for trip pulse generation has been optimised to make the output more robust against incorrect wiring and connection of incompatible trip coils.

Software fixes:

- »TCM« – Trip Circuit Monitoring [74TC] Bugfix: An external blocking signal assigned via [Protection Para / TCM] »TCM . ExBlo« did not lead to a blocking of the function.

12.4.2.1 Hotfix Version: 2.2

- Build Version: 66885
- Date: 2026-April-17

Fixes

Incorrect current measurements on phase L3

- Due to the microcontroller's specific behavior, which occurs in very rare cases, there may be occasional deviations in the A/D converter configuration. On occurrence, the measured current in phase L3 (50/60 Hz fundamental/rms values) show a significant overshoot for one 50/60 Hz period before reaching the steady-state value of zero. This condition persists for as long as the device is powered. Possible consequences are unwanted operation of protection or failure to operate.
- According to the proposed measures of the microcontroller manufacturer, a software fix has been implemented which identifies the misconfiguration of the A/D converter at device startup and corrects it immediately. The underlying issue affecting the device's (protection) functionality is then fully resolved.
- For more details see the Service Bulletin CAC_SEG_0170.

12.4.3 Version: 2.1

- Build Versions: 61213, 66886
- Date: 2023-July-15

Hardware

The WIC1-4 can now be ordered with an Ethernet interface, either via RJ45 or via an optical LC duplex interface. It can be used for the SCADA protocol *Modbus TCP*.

See [↔3.8 Ethernet Interface \(RJ45\)](#), [↔3.9 Ethernet / TCP/IP via Fiber Optics](#).

(The serial [RS485](#) interface with *Modbus RTU* is already available since [Version 2.0](#).)

Software

Modbus TCP is available now with an externally supplied WIC1-4 (if it has been ordered with an Ethernet interface, see "Hardware" above). See [↔4.2 Modbus® \(WIC1-4 only\)](#).

With an externally supplied WIC1-4, there is a new supervision function »Station Battery Monitoring« available. See [↔5.14.5 Condition Monitoring – Station Battery Monitoring \(WIC1-4 only*\)](#).

The previously available Fault Recorder has been enhanced into a Fault/Alarm Recorder. It now also collects the Alarm messages from those protection functions that have been configured as »Definition« = "Alarm". See [↔6 Fault/Alarm Recorder](#).

12.4.3.1 Hotfix Version: 2.1

- Build Version: 66886
- Date: 2026-April-17

Fixes

Incorrect current measurements on phase L3

- Due to the microcontroller's specific behavior, which occurs in very rare cases, there may be occasional deviations in the A/D converter configuration. On occurrence, the measured current in phase L3 (50/60 Hz fundamental/rms values) show a significant overshoot for one 50/60 Hz period before reaching the steady-state value of zero. This condition persists for as long as the device is powered. Possible consequences are unwanted operation of protection or failure to operate.
- According to the proposed measures of the microcontroller manufacturer, a software fix has been implemented which identifies the misconfiguration of the A/D converter at device startup and corrects it immediately. The underlying issue affecting the device's (protection) functionality is then fully resolved.
- For more details see the Service Bulletin [CAC_SEG_0170](#).

12.4.4 Version: 2.0

- Date: 2022-October-31

Hardware

The WIC1-4 can now be ordered with an RS485 interface. It can be used for the SCADA protocol *Modbus RTU*. See [↔3.7 Serial Interface RS485 \(WIC1-4... only\)](#).

Software

Modbus RTU is available now with a, externally supplied WIC1-4. See [↔4.2 Modbus® \(WIC1-4 only\)](#).

With an externally supplied WIC1-4, there is a new protection function »Cold Load Pickup« available. See [↔5.11 CLPU - Cold Load Pickup \(WIC1-4 only*\)](#).

A new supervision function »Breaker Wear« is available. See [↔5.14.1 BkrWear](#).

The menu item [Operation] has a sub-menu item [Condition Monitoring] now, with new entries:

- [Peak Current Ptr (Val.)] mimics an analog pointer instrument by calculating a time-average of the maximum phase current. See [↔5.14.4 Condition Monitoring - Peak Current Pointer](#).
- [Life Load] evaluates the operating time in dependency on the phase current flow and can (optionally) issue an alarm signal if the WIC1 has been running with too high load for a particular time. See [↔5.14.3 Condition Monitoring - Life Load](#).
- [BkrWear] the values of the new supervision function »Breaker Wear«. (See above.)

Both [Peak Current Ptr (Val.)] and [Life Load] allow for checking whether the WIC1 - and therefore the protected object as well - have been under high load. There are sub-menu items for displaying these two statistics either as a table of values or as a diagram (drag indicator graphics or histogram, respectively).

12.4.5 Version: 1.1

- Date: 2022-September-05

Hardware

No changes.

Software

Better support for the [Converter CTs](#). In particular, it is possible now to have primary current values displayed when using the 1 A or 5 A Converter CTs.

User Manual / Technical Documentation

Numbered input signals within a diagram are now hyperlinks, and a click takes you to a page where this numbered signal is explained or shown as an output signal.

(See also [↔2.5.1 Symbols in Function Diagrams](#).)

12.4.6 Version: 1.0

- Date: 2022-April-11

Hardware

Initial Version

- After several specimen delivered to selected customers for tests / approval, this is the initial release that has been made publicly available.

Software

Initial Release

12.5 Standards - WIC1

12.5.1 Approvals

	<p>Conformity for European Economic Area (CE).</p>
	<p>Conformity for Great Britain (UKCA).</p>
	<p>UL File Nr.: E217753 cULuc Certification of WIC1 and DiggiMEC - UL508, E217753 - NRGU (*) (*) Approval is not valid for an external supply above 24 VDC.</p>
	<p>KEMA Laboratories — Type tested and certified in accordance with the complete type test requirements of IEC 60255-1:2023</p>

12.5.2 Design Standards

<p>Generic standards</p>	<p>EN 61000-6-2 [2019] EN 61000-6-3 [2022]</p>
<p>Product standards</p>	<p>IEC 60255-1 [2022] IEC 60255-26 [2023] IEC 60255-27 [2023] IEC 60255-149 [2013] IEC 60255-151 [2009] IEEE C37.112 [2018]</p>

12.5.3 Electrical Tests

EMC Tests

Electrical Discharge Immunity Test (ESD)

IEC 60255-26 [03/14]	Air discharge	8 kV
DIN EN 61000-4-2 [12/09] class 3	Contact discharge	6 kV

Fast Transient Disturbance Immunity Test (Burst)

IEC 60255-26 [03/14]	Power supply, mains inputs	± 4 kV, 2.5 kHz
DIN EN 61000-4-4 [04/13] class 4	Other in- and outputs	± 2 kV, 5 kHz

Interference immunity against 1 MHz burst disturbance tests

IEC 60255-26 [03/14]	differential mode	2.5 kV, 1 MHz
DIN EN 61000-4-18 [09/20]	common mode	1 kV, 2 s

Interference immunity against surge immunity test

IEC 60255-26 [03/14]		4 kV / 2 kV
DIN EN 61000-4-5 [03/19]		

Interference immunity against high-frequent electromagnetic fields

IEC 60255-26 [03/14]		30 V/m
DIN EN 61000-4-3 [04/11]		

Interference immunity against magnetic fields of energy based frequency

IEC 60255-26 [03/14]	continuously	100 A/m
DIN EN 61000-4-8 [11/10]	3 s	1000 A/m

Interference immunity against line conducted interference quantities induced by high-frequent fields

IEC 60255-26 [03/14]		10 V/m
DIN EN 61000-4-6 [08/14]		

Interference immunity against surge voltage

IEC 60255-26 [03/14]	within a current circuit	1 kV
IEC 60255-27 [11/14]	current circuit to earth	5 kV

Measuring of the radio interference voltage

DIN EN 55011 [05/18]		Limit value class B
----------------------	--	---------------------

Measuring of the radio interference radiation

DIN EN 55011 [05/18]		Limit value class B
----------------------	--	---------------------

12.5.4 Safety-Related Tests

Overvoltage category	IEC 60255-27 [11/14]	III
Pollution degree	IEC 60255-27 [11/14]	3
Protection class	IEC 60255-27 [11/14]	II
Test of withstand alternating voltage for 1 min	IEC 60255-27 [11/14]	2.5 kV / 1 kV
Test of lightning surge voltage 1.2/50 μ s, 0.5 J	IEC 60255-27 [11/14]	5 kV / 1 kV
Inflammability	IEC 60255-27 [11/14]	rated
Single Defect Condition	IEC 60255-27 [11/14]	rated

12.5.5 Environmental Tests

Vibration and continuous vibration test:	IEC 60255-27 [11/14]	1 / 2 gn
	DIN EN 60255-21-1 [05/96]	Class 2
Shock and continuous shock test:	IEC 60255-27 [11/14]	10 / 20 gn
	DIN EN 60255-21-2 [05/96]	Class 2

Classification:		
IEC 60255-27 [11/14] DIN EN 60068-1 [09/15]	Climate category	<ul style="list-style-type: none"> • WIC1-1, WIC1-2, WIC1-3: 40/085/10 • WIC1-4: 40/060/10

Test Ad: Kälte		
IEC 60255-27 [11/14]	Temperature	−40°C
DIN EN 60068-2-1 [01/08]	Period of stress	16 h

Test Bd: Dry heat		
IEC 60255-27 [11/14] DIN EN 60068-2-2 [07/07]	Temperature	<ul style="list-style-type: none"> • WIC1-1, WIC1-2, WIC1-3: +85°C (185°F) • WIC1-4: +60°C (140°F)
	Rel. humidity	<50%
	Period of stress	72 h

Test Cab: Humid heat (constantly)		
IEC 60255-27 [11/14]	Temperature	+60°C (140°F)
IEC 60068-2-78 [02/14]	Rel. humidity	93%
	Period of stress	10 Tage

Test Db: Humid heat (cyclic)

IEC 60255-27 [11/14]	Temperature	<ul style="list-style-type: none"> • WIC1-1, WIC1-2, WIC1-3: +85°C (185°F) • WIC1-4: +60°C (140°F)
IEC 60068-2-30 [06/06]		
	Rel. humidity	95%
	Cycles (12 + 12 hours)	2

Test Eh: Hammer tests

EN IEC 62262 [02/02]	Test level	IK06 (1 Joule)
EN IEC 60068-2-75 [09/14]		

Index

A

ANSI

46	174, 177
49	181
50	157, 184
50BF	197
50N/G	167
51	157
51N/G	167
51Q	174, 177
62BF	197
diagram (functional overview)	3
Alarm-/Trip Cause display	212
Auto Fault Report	212
Auto Refresh	26
access password	56
asterisk "*"	122
auxiliary voltage supply	90

B

Backup (phase overcurrent) Protection	220
BkrWear	199

C

CBF	197
CLPU	190
CTs	
WIC1-Wx	77
properties	74
quick selection	79
selection / example calculation	77

test windings 227

“E”-type 79

Circuit breaker failure protection module 197

Cold Load Pickup Module 190

Condition Monitoring 205, 207

Converter CTs (1 A) 80

characteristics (earth/ground overcurrent) 324

characteristics (phase overcurrent) 306

characteristics (unbalanced load) 343

circuit breaker 149

configuration via Smart view (offline) 26

D

DEFT (Unbalanced Load-Stage characteristic) 345

DEFT (earth/ground overcurrent characteristic) 326

DEFT (phase overcurrent characteristic) 308

DIP switches 58

 Settings Overview 297

 validity of settings 25

Device Model 25

DiggiMEC 23, 37, 119

 Favorites key »★« 117

 Introduction 112

 flag indicators – output relays 130

 front panel parts 114

DiggiMEC LEDs

 default setting 133

DiggiMEC flag indicators / output relays

 Set + Reset 130

 default setting 133

 position, terminals, connectors 125

DiggiMEC flag indicators – output relays	
latching	131
testing	132
Digital Input	88, 89, 90
Digital Inputs (for position indication)	150
Direct Commands	47
Dual-Powered WIC1	20
date and time	57
device start	217
dual power	90

E

EF Curve (Unbalanced Load-Stage characteristic)	359
EF Curve (earth/ground overcurrent characteristic)	340
EF Curve (phase overcurrent characteristic)	322
Ethernet	95, 96
external protection	
function	194
input	88
external reset	90
external trip	90

F

FR Fuse (Unbalanced Load-Stage characteristic)	354
FR Fuse (earth/ground overcurrent characteristic)	335
FR Fuse (phase overcurrent characteristic)	317
Fault Display screen (Overlay / Pop-up)	212
Favorites key »★«	117
factory defaults (reset)	26, 55, 119

fiber optic	96
flag indicator	99
flag indicators / output relays	
DiggiMEC	125
flag indicators - output relays	
DiggiMEC	130
default setting DiggiMEC	133
force trip command	146
functional overview	3
fused contactor	149

G

Ground (earth) current protection stage	167
---------------------------------------------------	-----

H

HEX switches	58
Settings Overview	297
validity of settings	25
HMI	23, 114, 119
HV Fuse (Unbalanced Load-Stage characteristic)	353
HV Fuse (earth/ground overcurrent characteristic)	334
HV Fuse (phase overcurrent characteristic)	316

I

I2/I1>	174
I2>	177
I>	157
I>>	157
I>>>	157
IEC EINV (Unbalanced Load-Stage characteristic)	350

IEC EINV (phase overcurrent characteristic)	313
IEC LINV (Unbalanced Load-Stage characteristic)	351
IEC LINV (phase overcurrent characteristic)	314
IEC NINV (Unbalanced Load-Stage characteristic)	348
IEC NINV (phase overcurrent characteristic)	311
IEC VINV (Unbalanced Load-Stage characteristic)	349
IEC VINV (phase overcurrent characteristic)	312
IEC EINV (earth/ground overcurrent characteristic)	331
IEC LINV (earth/ground overcurrent characteristic)	332
IEC NINV (earth/ground overcurrent characteristic)	329
IEC VINV (earth/ground overcurrent characteristic)	330
IEC 60870-5-103	91
IEEE EINV (Unbalanced Load-Stage characteristic)	358
IEEE EINV (phase overcurrent characteristic)	321
IEEE MINV (Unbalanced Load-Stage characteristic)	356
IEEE MINV (phase overcurrent characteristic)	319
IEEE VINV (Unbalanced Load-Stage characteristic)	357
IEEE VINV (phase overcurrent characteristic)	320
IEEE EINV (earth/ground overcurrent characteristic)	339
IEEE MINV (earth/ground overcurrent characteristic)	337
IEEE VINV (earth/ground overcurrent characteristic)	338
IG>	167

IG>>	167
IH2	163
Ipeak>	184
impulse output	
flag indicator	99
trip coil	98
K	
keys	
OK	122
keys during power-on	119
L	
LC connector	96
LED	
Error	58, 104, 104
Pickup/Trip	58, 104
Ready	58, 104, 104
System (Ready/Error)	104
LED Test	107, 116
LED »System«	238
LEDs	
DiggiMEC	104, 107, 107
Latching	107
Pickup / TripCmd	107
System LED	104
Trip Command	107
WIC1	104, 107
configuration	107
default setting DiggiMEC	133
Life Load	51, 205
Load Current Histogram	205

M

Measured Value	47
Modbus	91, 136
Modbus TCP	95, 96
Module Input	47
Module Inrush	163
manual trip command	146
measured values	
display options	49
menu structure	120
message (self-supervision)	218

N

Negative-Sequence Current Protection	177
navigation	114

O

Order Form (Order Code)	36
offline configuration	26
operating mode	
Backup Protection	220
Protection-Only	105, 220
output relays / flag indicators	
DiggiMEC	125
output relays – flag indicators	
DiggiMEC	130
default setting DiggiMEC	133

P

PC	23, 110
PC4	23, 110, 263
Parameters	47
Peak Current Ptr	51, 207

Peak-Value Overcurrent 184

Phase Overcurrent Stage 157

Primary test 229

Protection-Only mode 220

panel 114, 119

parameters 122

password 56

passwords

 reset 56

position indication 150

position indication (switchgear) 149

Q

question mark “?” (parameter implausibility) 124

R

RINV (Unbalanced Load-Stage characteristic) 352

RINV (earth/ground overcurrent characteristic) 333

RINV (phase overcurrent characteristic) 315

RJ45 95

RS485 91

RXIDG (earth/ground overcurrent characteristic) 342

Receive Data from Device 24

Recorder

 Fault/Alarm Recorder 210

Restart (reboot) 238

reboot 217

reboot codes 217

remote trip input 88

reset

 Alarm-/Trip Cause display 52, 212

LEDs	52
flag indicators	52
to factory defaults	52
reset delay (earth/ground overcurrent)	324
reset delay (phase overcurrent)	306
reset delay (unbalanced load)	343
reset latched states	52
reset to factory defaults	26, 55, 119

S

SBM	208
SOTF	187
Security Logger	56
Self-Supervision Contact	100
Self-Supervision messages	218
Signals	47
Smart view	24, 37
Auto Refresh	26
Receive Data from Device	26
Station Battery Monitoring	208
Statistic	205
Statistik	207
Supply of a WIC1	27
Sweden curve (Unbalanced Load-Stage characteristic)	354
Sweden curve (earth/ground overcurrent characteristic)	335
Sweden curve (phase overcurrent characteristic)	317
Switch Onto Fault - Module	187
System-LED	238
scaling of measured values	49
secondary test	229
security-related messages	218

serial interface	91
setting values	122
start-up codes	217
switchgear	149
system time	57

T

ThR	181
Thermal Overload	181
Typecode (see Order Form)	36
terminals	
max. torques of the screws	61, 127
test sockets	58, 227, 228, 230
time, date	57
torque (max. t. of the screws)	61, 127
trip delay	239
trip delay (earth/ground overcurrent)	324
trip delay (phase overcurrent)	306
trip delay (unbalanced load)	343

U

USB	23, 110
Unbalanced Load Protection	174

V

Values	47
--------------	----

W

WI1-SZ4, WI1-SZ5	99
WIC1 g1	19
WIC1 g2	19
WiPara file	47



⚙ Signal References in Function Diagrams

(10)	151, 152, 153, 153, 154
(11)	151, 152, 153, 153, 154
(12)	151
(18)	142
(19)	141, 158, 168, 175, 178, 182, 185, . 188, 195
(20)	141, 159, 168, 175, 178, 182, 185, . 188, 195, 198, 203
(21)	141, 159, 168, 175, 178, 182, 185, . 188, 195
(24)	158
(25)	158
(26)	158
(27)	168, 185
(28)	185
(29)	185
(30)	151
(31)	151
(32)	149
(34)	159
(35)	159
(36)	159
(37)	168, 185
(38)	185
(39)	185
(44)	158
(45)	158
(46)	158
(49)	141, 144
(50)	141
(51)	141, 145



(52)	141
(53)	221
(61)	144
(62)	144
(63)	144
(1)	142
(2)	148, 203
(3)	142
(5)	164
(6)	164
(7)	164
(8)	164

WI Line

WIC1

MANUAL

docs.SEGelectronics.de/wic1

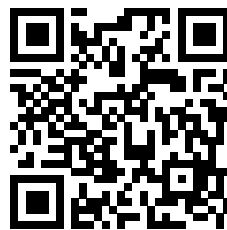

SEG Electronics GmbH reserves the right to update any portion of this publication at any time.
Information provided by SEG Electronics GmbH is believed to be correct and reliable.
However, SEG Electronics GmbH assumes no responsibility unless otherwise expressly undertaken.



SEG Electronics GmbH
Krefelder Weg 47 • D-47906 Kempen (Germany)
Telephone: +49 (0) 21 52 145 0
Internet: www.SEGelectronics.de

Sales
Telephone: +49 (0) 21 52 145 331
Fax: +49 (0) 21 52 145 354
E-mail: sales@SEGelectronics.de

Service
Telephone: +49 (0) 21 52 145 600
Fax: +49 (0) 21 52 145 354
E-mail: support@SEGelectronics.de

Complete address / phone / fax / email information for all locations is available on our website.