

/1.6
/1.6
/1.6
/1.6
/1.7
/1.7
/1.7
/1.7
/1.8

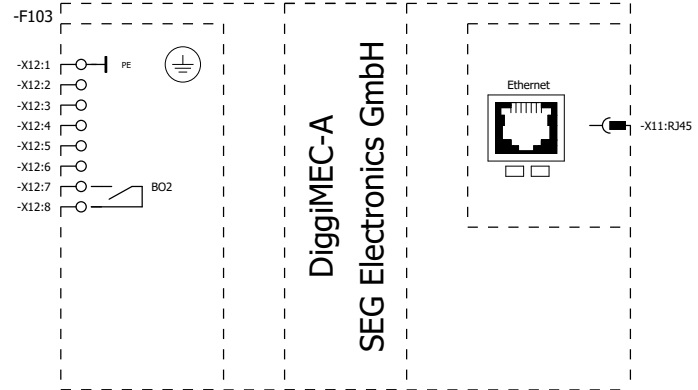

DiggiMEC-A
SEG Electronics GmbH

/1.6

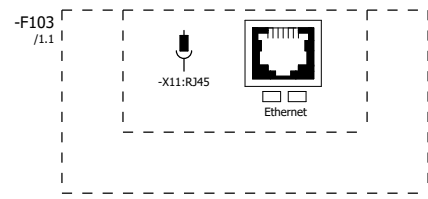
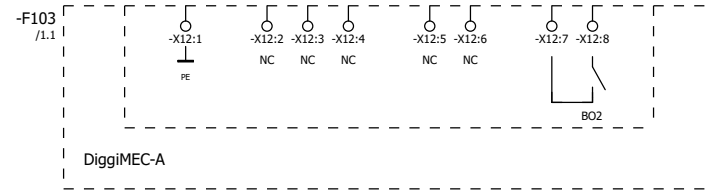

+DiggiMECB/2

		Datum	31.10.2023	SEG EPLAN MACRO	
		Bearb.	dennis.voelkel		
		Gepr		WIC1 2g Projekt	
Änderung	Datum	Name	Urspr	Ersatz von	Ersetzt durch



DiggiMEC-A

		=	
		+ DiggiMECA	
	SEG_AB20231076	Blatt	1
		Seite	1 / 12

/2.6
/2.6
/2.6
/2.6
/2.7
/2.7
/2.7
/2.8

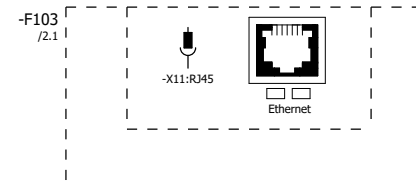
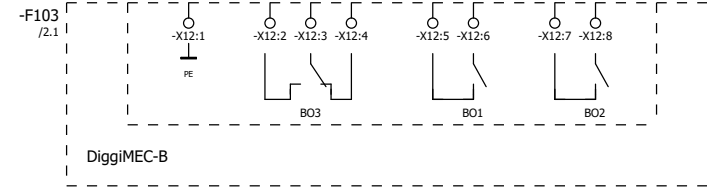
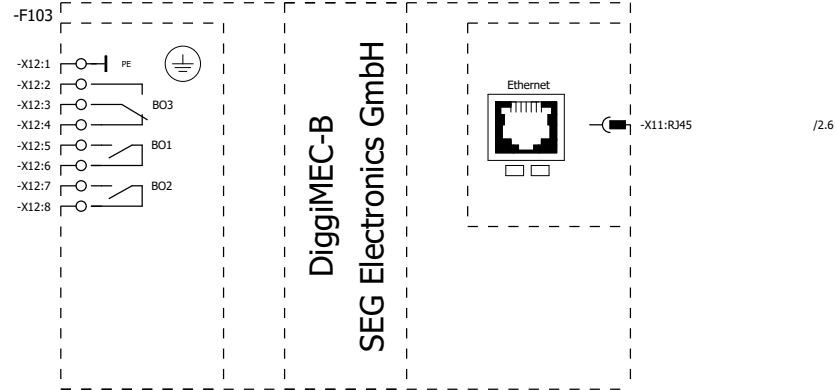

+DiggiMECA/1

+WIC11SNA/3

Datum	31.10.2023	SEG EPLAN MACRO
Bearb.	dennis.voelkel	
Gepr		WIC1 2g Projekt
Änderung	Datum	Name
Urspr		Ersatz von
		Ersetzt durch



DiggiMEC-B

SEG_AB20231076

=	
+ DiggiMECB	
Blatt	2
Seite	2 / 12

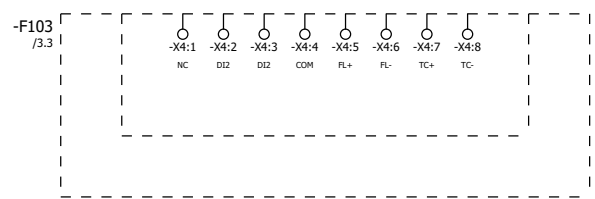
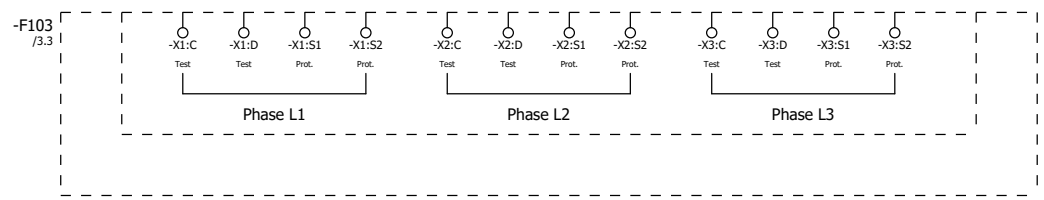
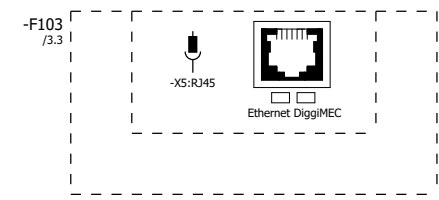
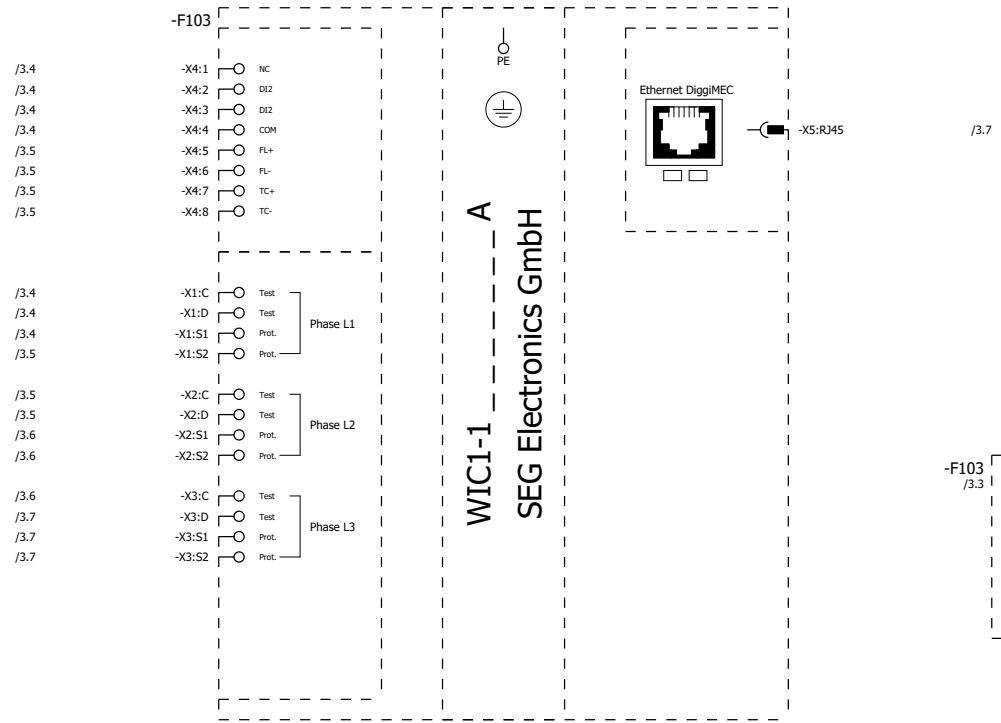

+DiggiMECB/2

+WIC11SGA/4

Datum	31.10.2023	SEG EPLAN MACRO
Bearb.	dennis.voelkel	
Gepr		WIC1 2g Projekt
Änderung	Datum	Name
	Urspr	Ersatz von
		Ersetzt durch



WIC1-1SN _ _ _ _ A

SEG_AB20231076

=	
+ WIC11SNA	
Blatt	3
Seite	3 / 12

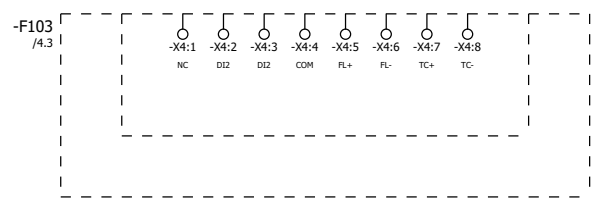
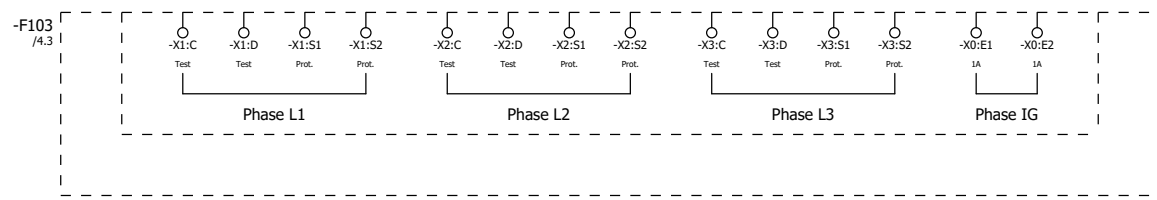
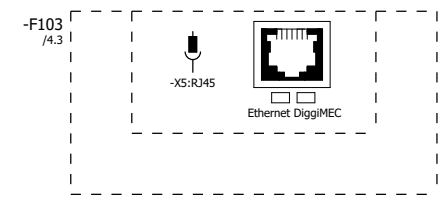
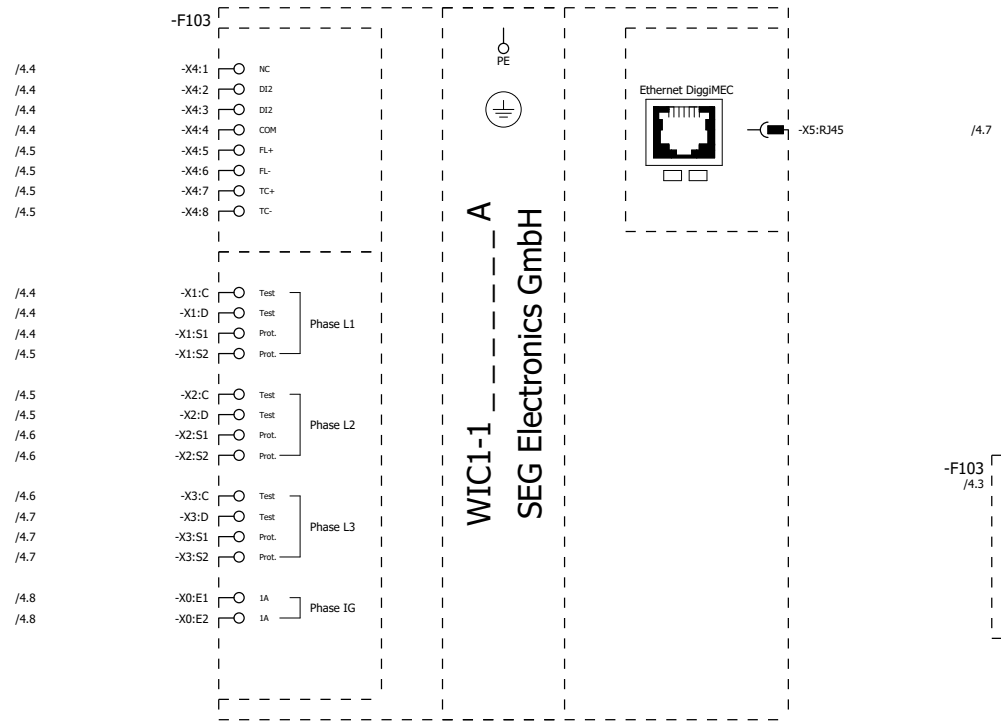

+WIC11SNA/3

+WIC12SNA/5

Datum	31.10.2023	SEG EPLAN MACRO
Bearb.	dennis.voelkel	
Gepr		WIC1 2g Projekt
Änderung	Datum	Name
Urspr		Ersatz von
		Ersetzt durch



WIC1-1SG _ _ _ _ A

SEG_AB20231076

=
+ WIC11SGA

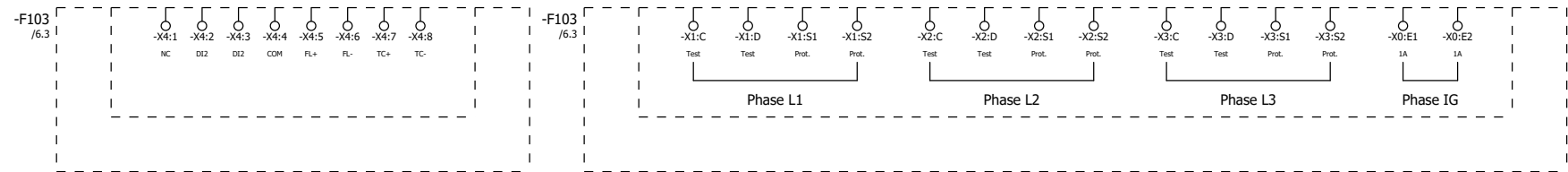
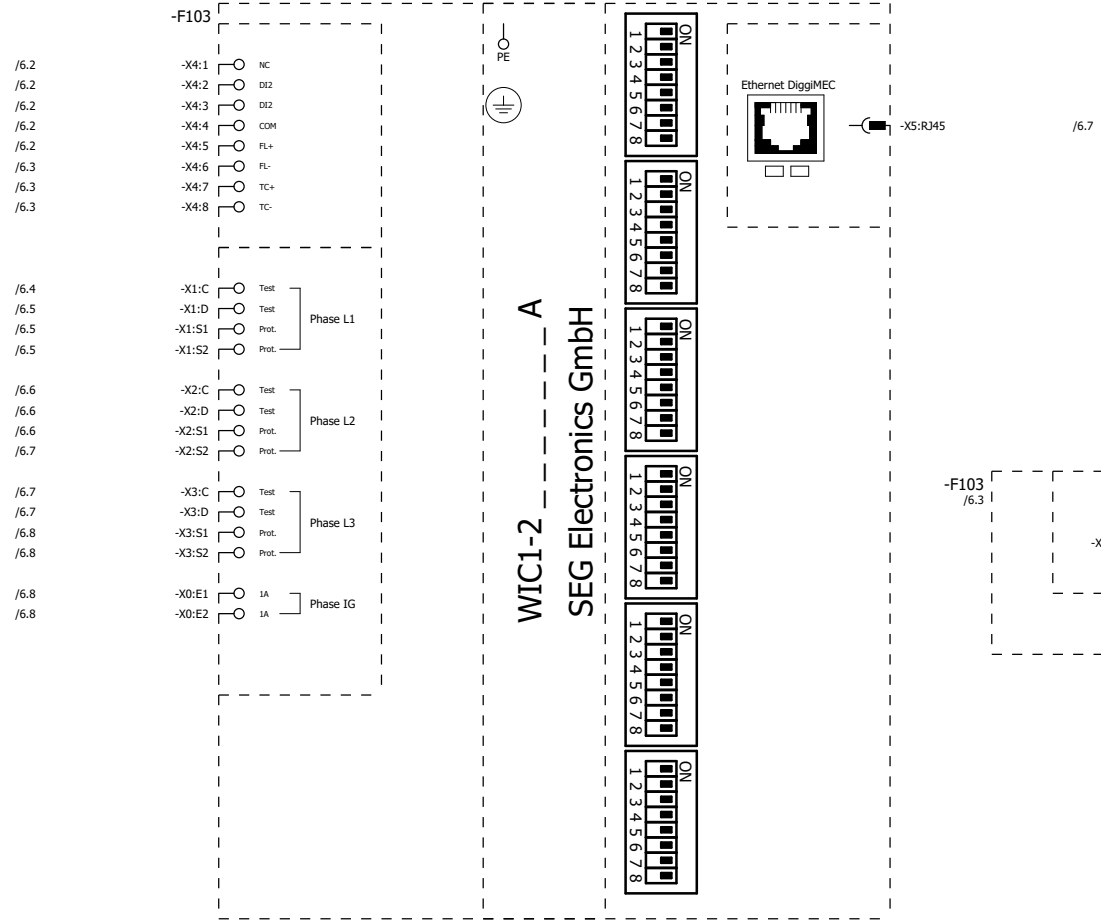

+WIC12SNA/5

+WIC13SNA/7

Datum	31.10.2023	SEG EPLAN MACRO
Bearb.	dennis.voelkel	
Gepr		WIC1 2g Projekt
Änderung	Datum	Name
	Urspr	Ersatz von
		Ersetzt durch



WIC1-2SG _ _ _ _ A

		SEG_AB20231076	Blatt 6
			Seite 6 / 12

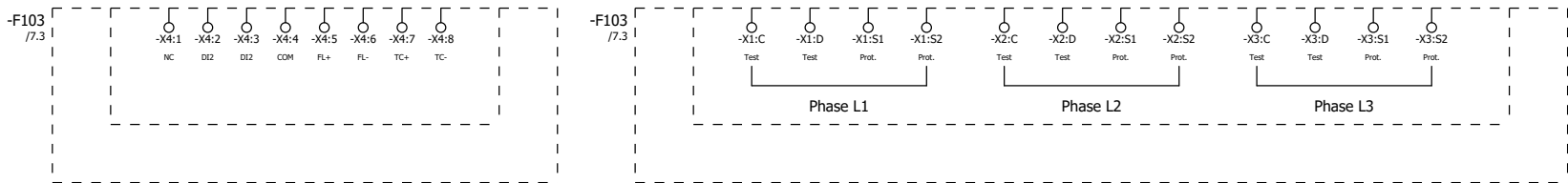
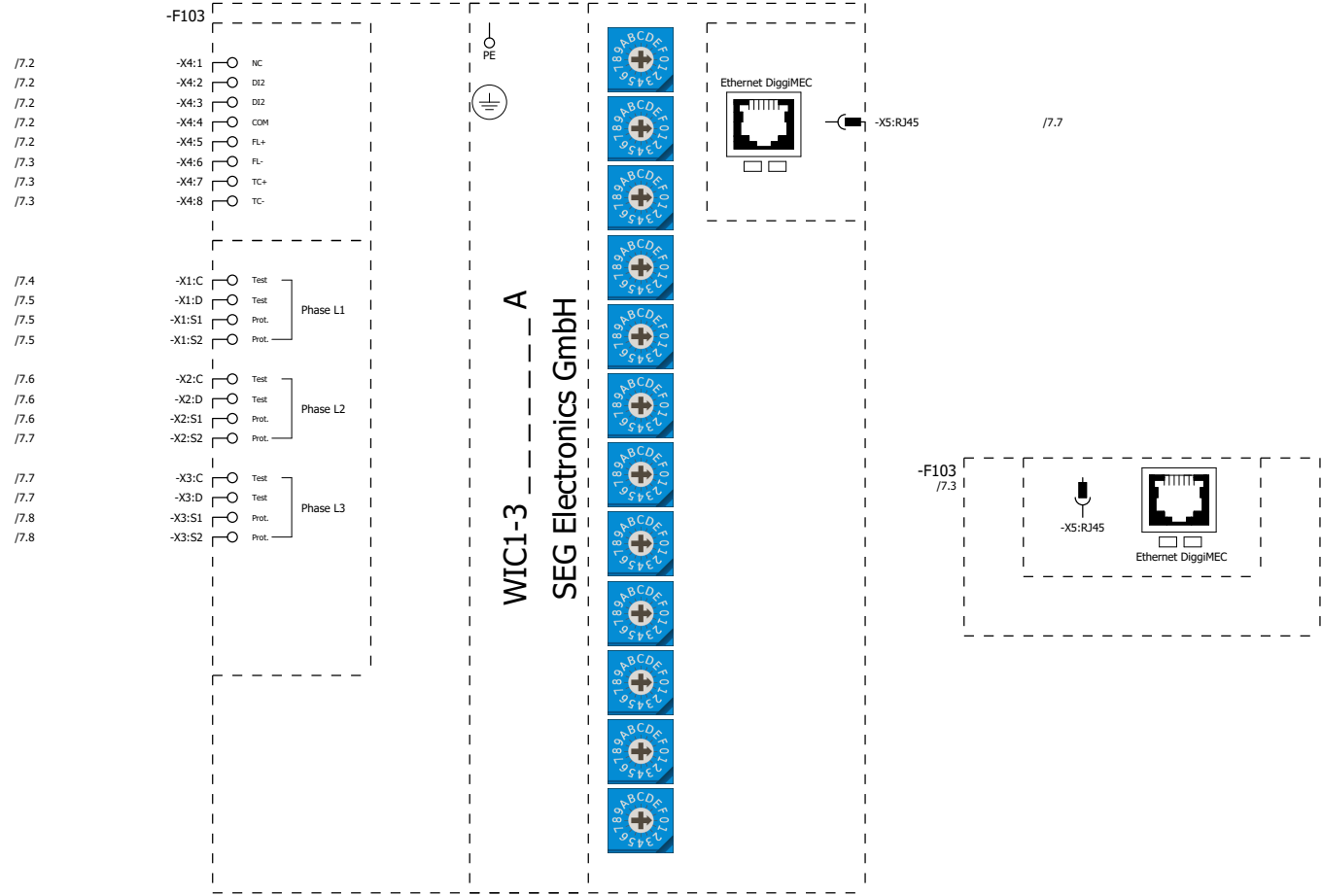

+WIC12SGA/6

+WIC13SGA/8

Datum	31.10.2023	SEG EPLAN MACRO
Bearb.	dennis.voelkel	
Gepr		WIC1 2g Projekt
Änderung	Datum	Name
Urspr		Ersatz von
		Ersetzt durch



WIC1-3SN _ _ _ _ A	=	
	+ WIC13SNA	
SEG_AB20231076	Blatt	7
	Seite	7 / 12

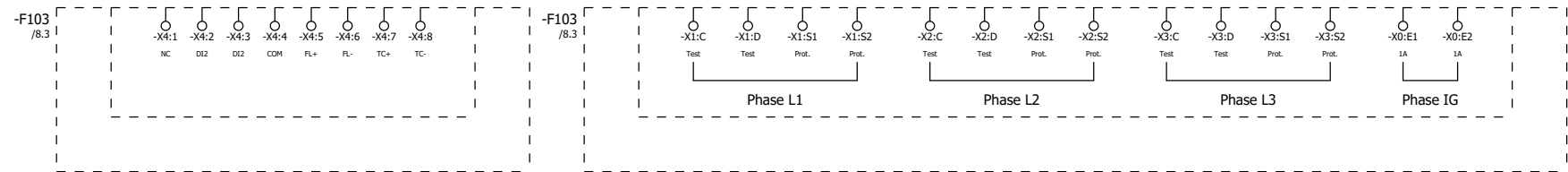
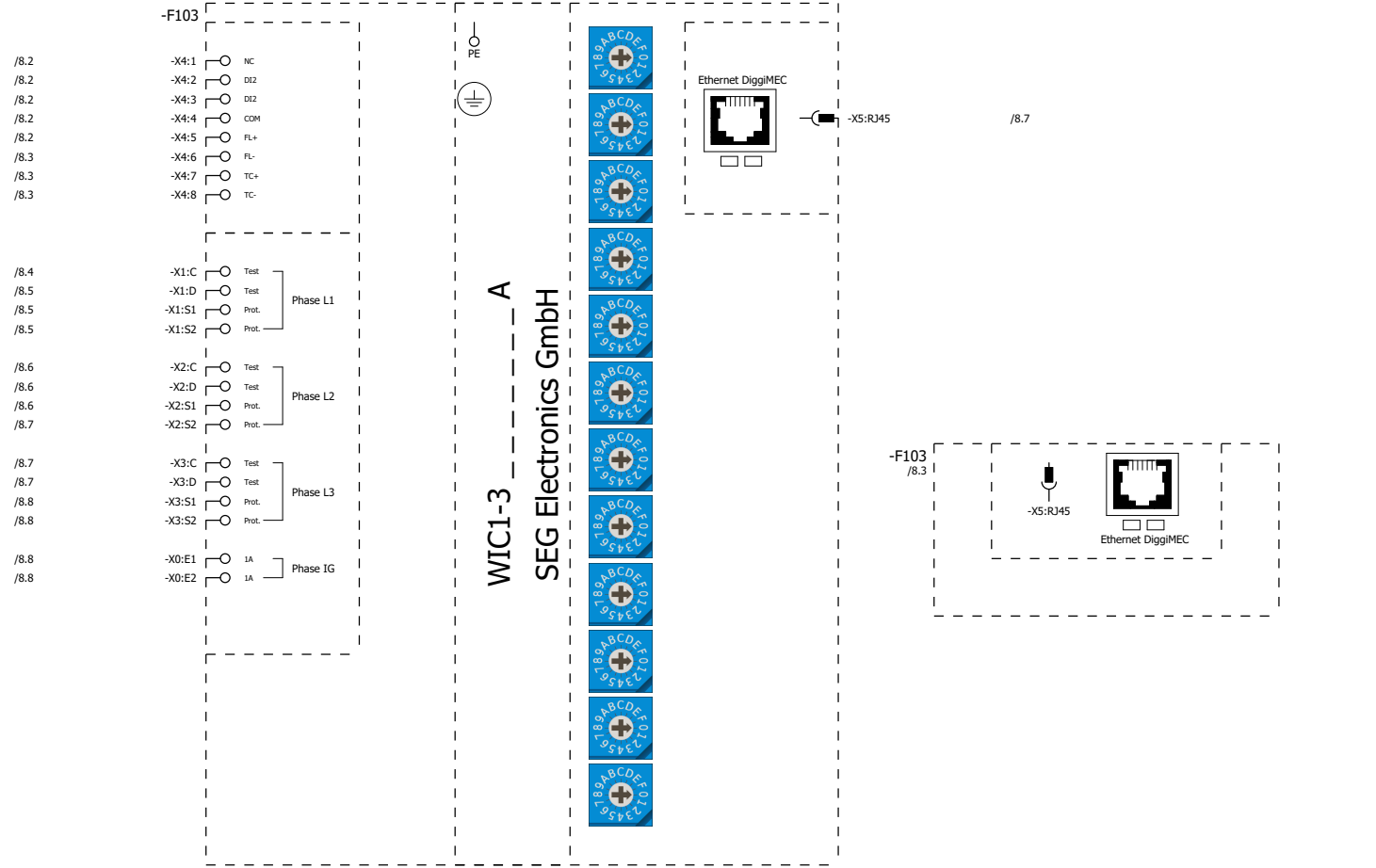

+WIC13SNA/7

+WIC14A/9

Datum	31.10.2023	SEG EPLAN MACRO
Bearb.	dennis.voelkel	
Gepr		WIC1 2g Projekt
Änderung	Datum	Name
Urspr		Ersatz von
		Ersetzt durch



WIC1-3SN _ _ _ _ _ A	=	
	+ WIC13SGA	
SEG_AB20231076	Blatt	8
	Seite	8 / 12

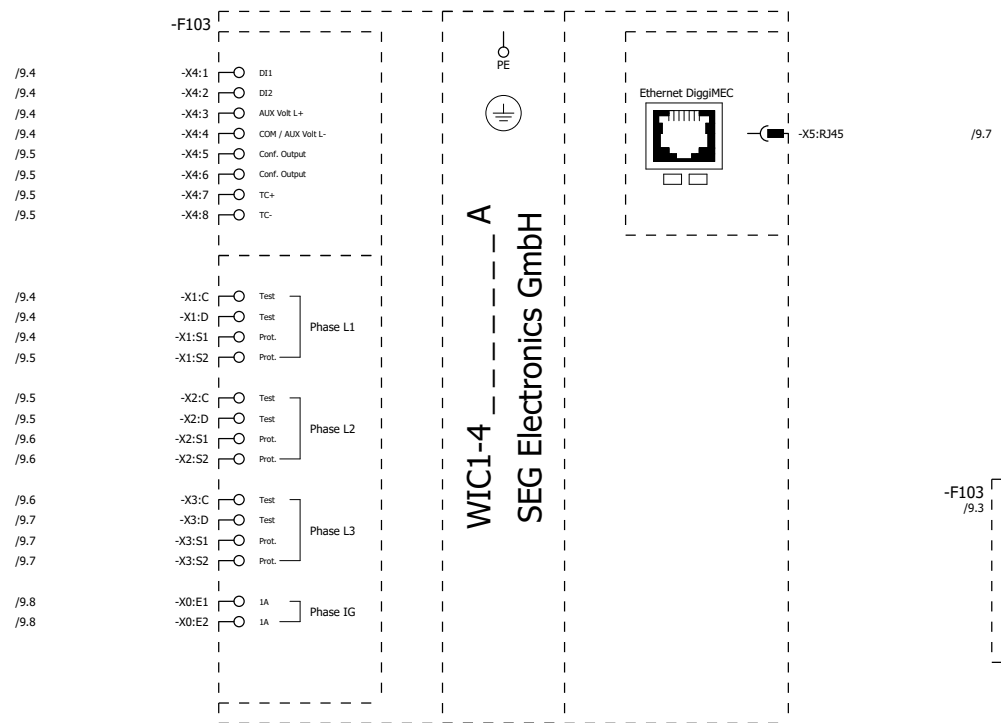

/9.4
/9.4
/9.4
/9.4
/9.5
/9.5
/9.5
/9.5
/9.5
/9.4
/9.4
/9.4
/9.5
/9.5
/9.5
/9.6
/9.6
/9.6
/9.6
/9.7
/9.7
/9.7
/9.8
/9.8

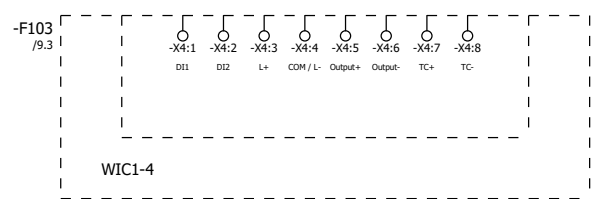
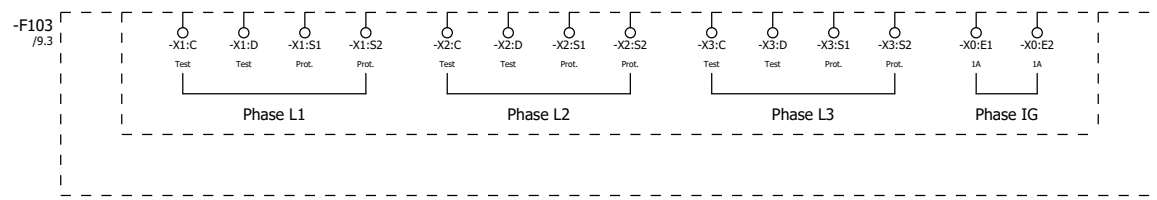
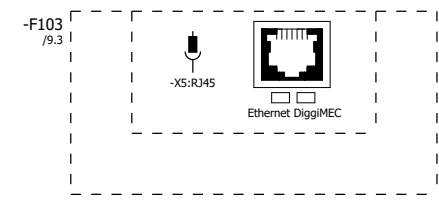

+WIC13SGA/8

+WIC14B/10

Datum	31.10.2023	SEG EPLAN MACRO
Bearb.	dennis.voelkel	
Gepr		WIC1 2g Projekt
Änderung	Datum	Name
Urspr		Ersatz von
		Ersetzt durch



WIC1-4SG _ _ _ _ A

		=
		+ WIC14A
SEG_AB20231076		Blatt 9
		Seite 9 / 12

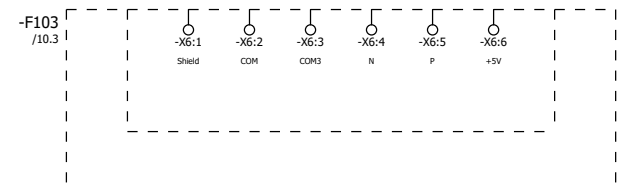
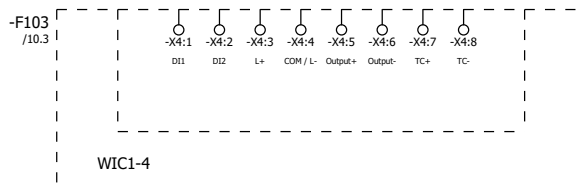
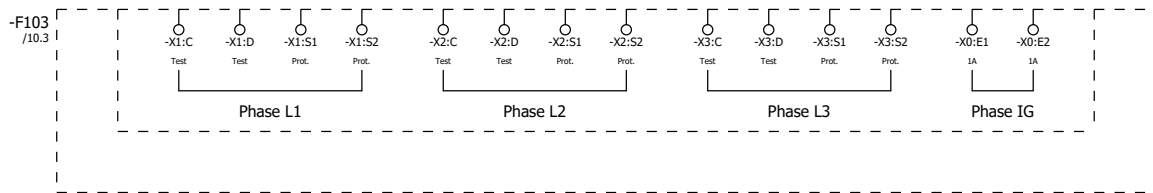
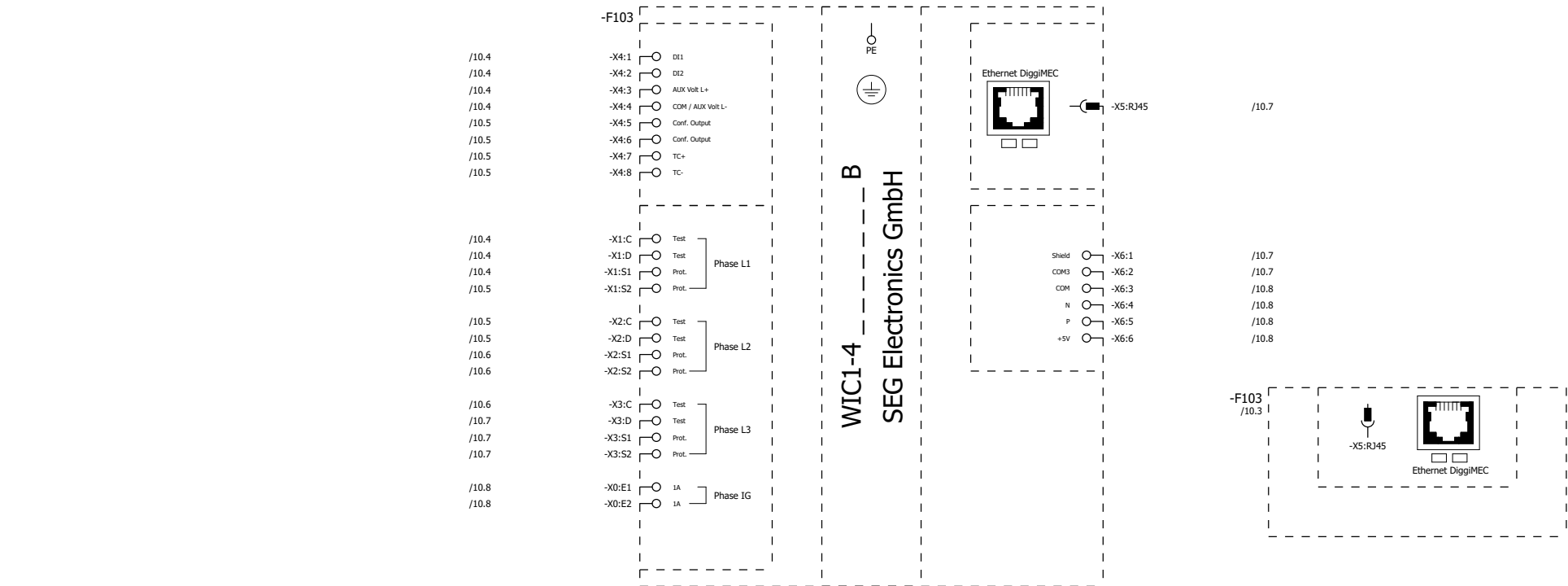

+WIC14A/9

+WIC14C/11

Datum	31.10.2023	SEG EPLAN MACRO
Bearb.	dennis.voelkel	
Gepr		WIC1 2g Projekt
Änderung	Datum	Name
Urspr		Ersatz von
		Ersetzt durch



WIC1-4SG _ _ _ _ B

=		
+ WIC14B		
SEG_AB20231076	Blatt	10
	Seite	10 / 12

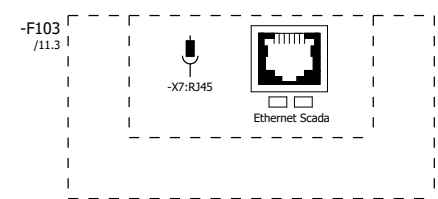
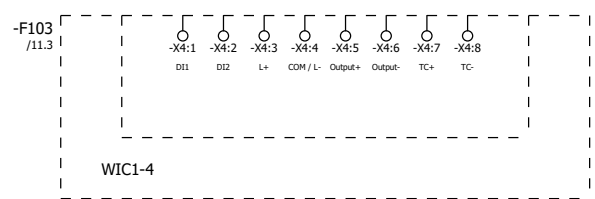
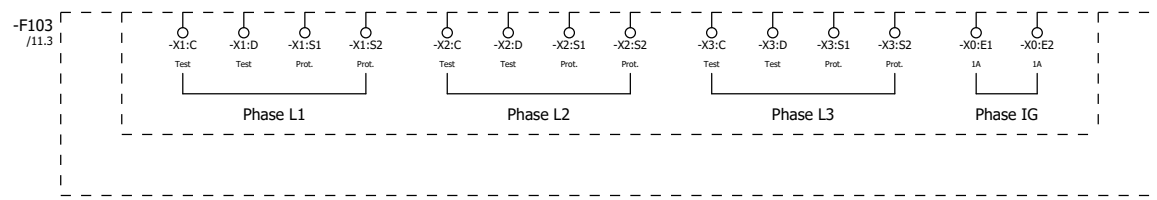
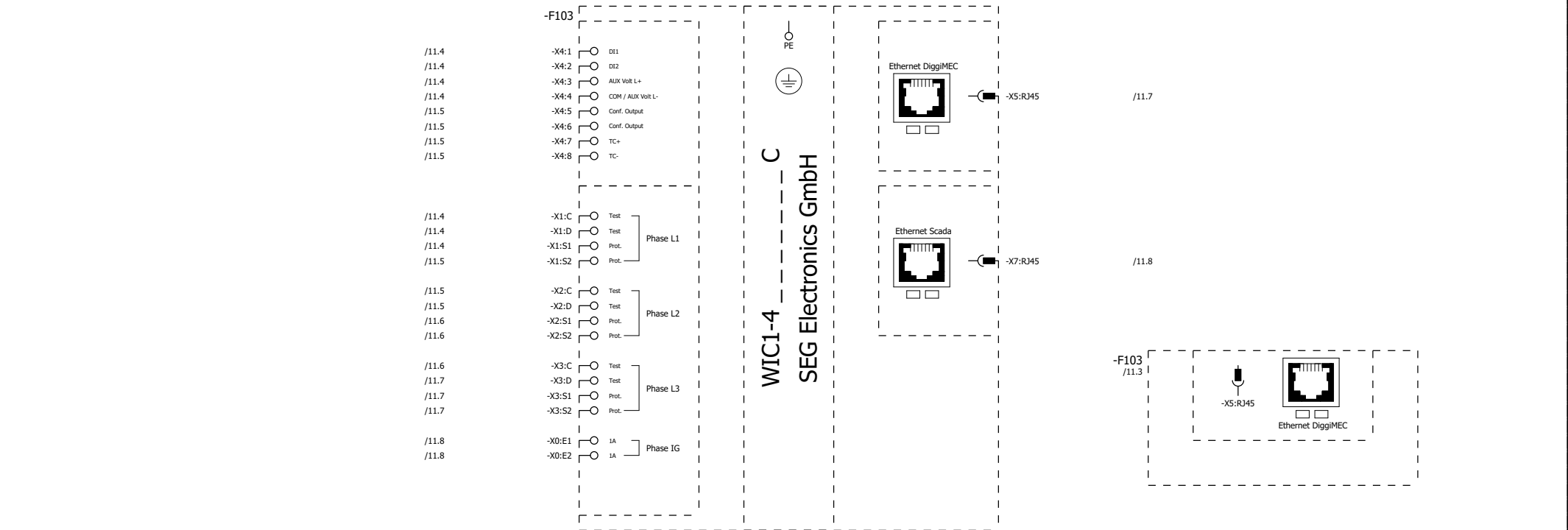

+WIC14B/10

+WIC14L/12

Datum	31.10.2023	SEG EPLAN MACRO
Bearb.	dennis.voelkel	
Gepr		WIC1 2g Projekt
Änderung	Datum	Name
Urspr		Ersatz von
		Ersetzt durch



WIC1-4SG _ _ _ _ C

		=
		+ WIC14C
SEG_AB20231076	Blatt	11
	Seite	11 / 12

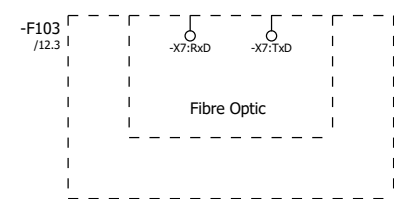
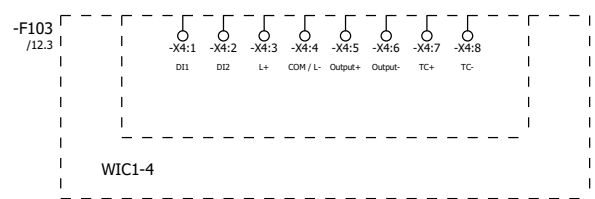
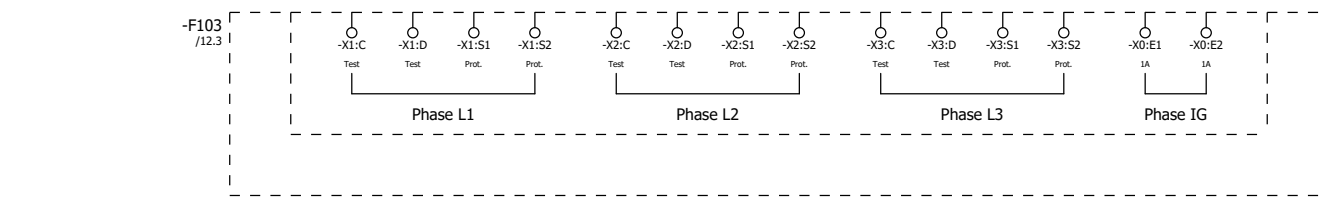
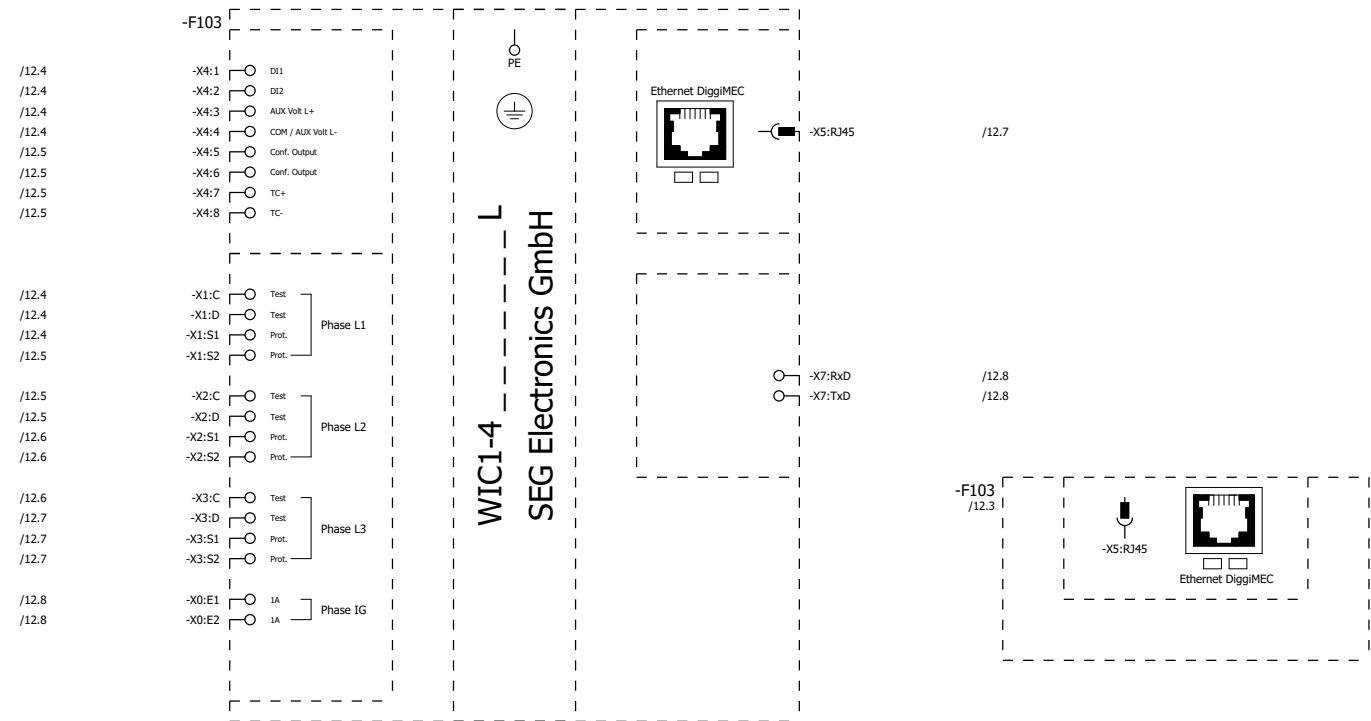

+WIC14C/11

Datum	31.10.2023	SEG EPLAN MACRO
Bearb.	dennis.voelkel	
Gepr		WIC1 2g Projekt
Änderung	Datum	Name
	Urspr	Ersatz von
		Ersetzt durch



WIC1-4SG _ _ _ _ L

		=
		+ WIC14L
	SEG_AB20231076	Blatt 12
		Seite 12 / 12