

PROTECTION MADE SIMPLE.

- New Features - Release 2.1**
- ▶ Modbus TCP via RJ45 or Fiber Optics
 - ▶ Station Battery Monitoring
 - ▶ Alarm Recorder

WIC1 Family - Self / Dual

The WIC1 family is a series of self-powered / CT powered protection relays, designed for harshest environments. The WIC relay family does not need auxiliary energy since they are CT powered. A dual/redundant powered variant enables communication options (*) in addition to the power outage safe protection core. The main applications are:

- ▶ Protection of Ring Main Units for Power Distribution
- ▶ Protection of Step-Up Transformers e.g. for Wind and Solar Power
- ▶ Protection of Feeders
- ▶ Current based protection when auxiliary power is not available or too costly
- ▶ Backup Protection - available in absence of auxiliary power
- ▶ Disaster recovery - Blackstart capability after (short or long lasting) outages - reliable protection, when other protection relays fail because of drained battery rooms

DiggiMEC® - Nano HMI + Flag Indicators

The DiggiMEC® is an upgrade option to the WIC1 family. It is a Nano-HMI with up to three integrated mechanical flag indicators. Its display can visualize measuring values on site. Moreover, the DiggiMEC® provides access to the protection parameters that are always exclusively inside the WIC relay.

Software settings (offline created) can be loaded into the WIC1 relays via the USB-C port of the DiggiMEC®.

Fault analysis is easy because Auto-Fault reports will pop up on the display. The configurable mechanical flag indicators show trip relevant information in a power outage safe manner.

WIC1

SELF-/DUAL-POWERED PROTECTION RELAY



DiggiMEC®

NANO HMI FOR WIC1 WITH FLAG INDICATORS

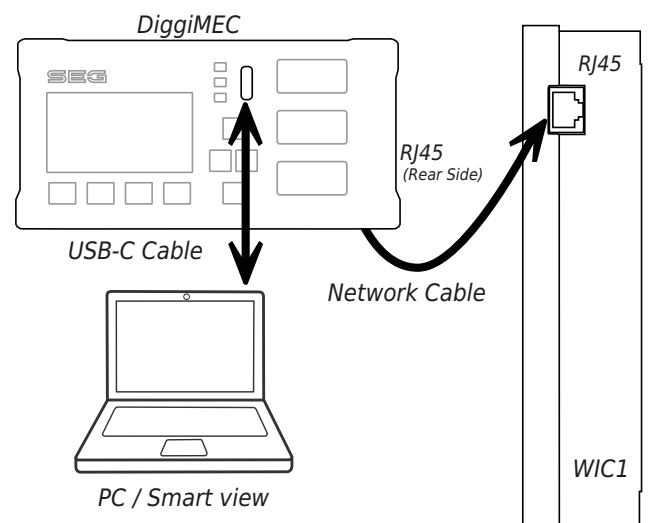
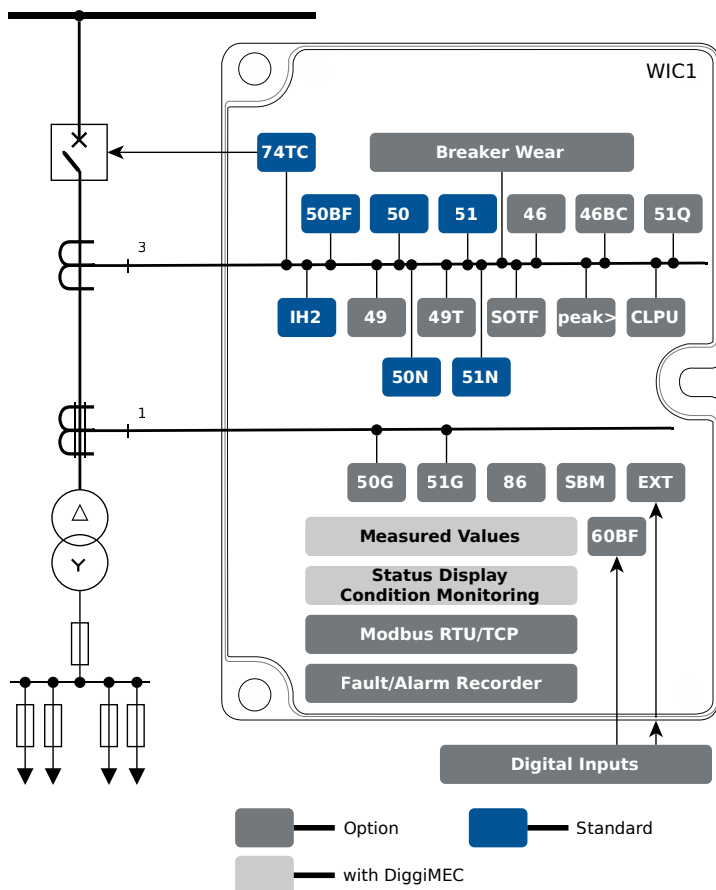

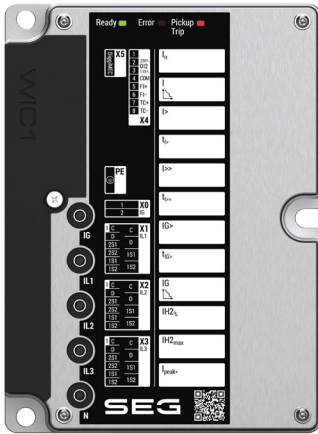

WIC1-1

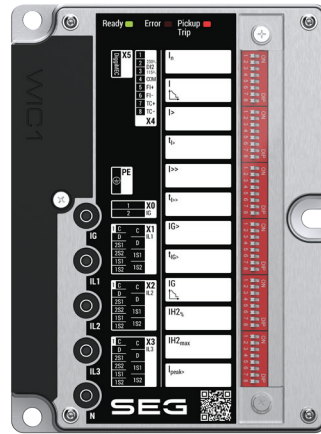

WIC1-2

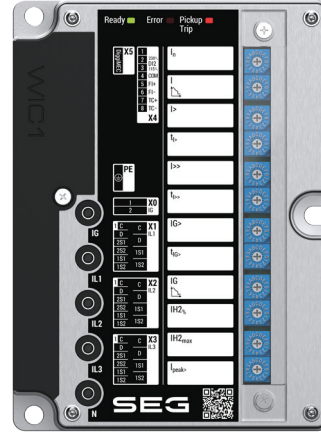

WIC1-3

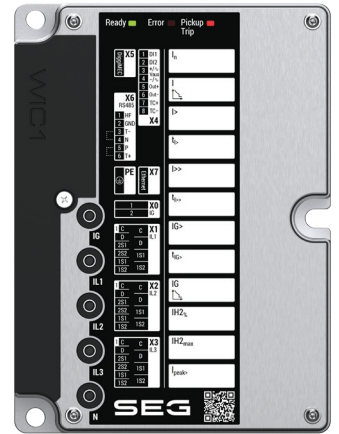

WIC1-4

Self- or Dual-Powered

The WIC1 relays harvest the required supply energy from the current measurement signals. No auxiliary power needed. A dual (redundant) powered variant is available in order to enable e.g. communication^(#) and early ground (earth) fault detection.

Inrush Blocking

Adapt the inrush element to your needs in order to prevent faulty inrush tripping. The inrush element can also be set via DIP/HEX switches. In particular, it has a full-featured inrush Blocking, with settable thresholds (also via DIP / HEX).

Communication^(#)

The WIC1-4 features the Modbus RTU protocol via RS485 interface, or Modbus TCP via electrical or optical Ethernet.

Sub-Cycle Boot-up Time

With a start-up time of less than 1 cycle, the WIC1 already protects your equipment whilst other devices are still booting. What if someone is switching onto a fault although the system is still grounded during maintenance? The WIC1 will issue a trip signal almost immediately.

Ultra Fast Overcurrent

There is an optional ultra-fast Peak Value Overcurrent protection available now. The WIC1 can trip on critical currents within less than a cycle, including boot and charge time. This element can be used to minimize damage to your equipment in case of very high short circuit currents or to minimize SOTF (option) tripping times.

(#) = Modbus RTU / RS485 available as of R2.0.
Modbus TCP via RJ45 or fiber optics available as of R2.1

No Drilling, no Sawing for Retrofit

The WIC1 has the same form-factor as the predecessor. You can mount it into the cabinet in just a few minutes. No cabinet needs to be redesigned. No drilling, no sawing will be necessary.

You can re-use the previously installed WIC1 CTs: Just switch over the connection cables.

The first DIP switch blocks (WIC1-2) / HEX switches (WIC1-3) have the same function as the first WIC1 version, so that the settings are quickly copied.

Made for Harsh Environment

It is no problem for the WIC1 if the RMU / transformer is in an area with harsh climate, for example high humidity all the year, or an average temperature above 50°C.

Ground Current

The WIC1 offers calculated and measured 1 A ground current (option).

Tripping Characteristics

For inverse-time overcurrent protection, you can select out of 12 characteristics (ground overcurrent: 13)

- ▶ **New:** Eaton-Cooper "EF"-curve and 3 new IEEE curves
- ▶ **New:** Minimum tripping time for INV characteristics

WIC1-4 with Modbus TCP/Ethernet via Fiber Optics^(#)

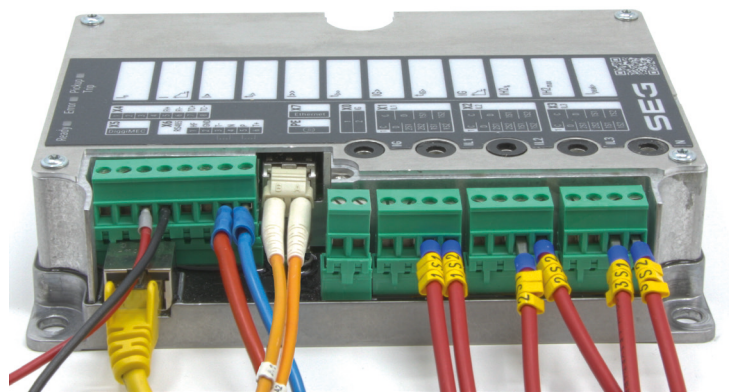

Benefits of the DiggiMEC® Upgrade Option

The DiggiMEC® is an HMI upgrade option to the WIC1. It offers integrated Flag Indicators and configurable LEDs and can be mounted in no time and without any drilling. Just connect the DiggiMEC® and WIC1 relay via a standard Ethernet cable.

Settings via DiggiMEC®

Access on all / additional protective elements

Setting of protective elements beyond DIP/HEX switches

- ▶ Alternative Flag Indicator Assignments
- ▶ I>>> (Third Overcurrent Element)
- ▶ IG>> (Second Ground Current Element)
- ▶ Thermal Protection
- ▶ Option for flexible use of the FI (flag indicator) output of the WIC1, e. g. for measuring alarm times, or as a watchdog output (with external DIN rail output relay)

Condition Monitoring

- ▶ Breaker Wear
- ▶ Live Measurement Values Transformer Life Load Monitoring ^(2.0)
- ▶ Peak Current Pointer ^(2.0)



Commissioning Support

- ▶ Force manually relay positions
- ▶ Trip Indicators (manual reset option)
- ▶ Test Trip (powered via USB)

The Auto Fault Report Tells You what has Happened

- ▶ Information comes to you: Fault reports will pop up on the display automatically.
- ▶ Mechanical Flag Indicators indicate in a power outage safe manner what has happened.

Protection	Description	Elements	
50, 51	Phase Overcurrent	3* / 2**	●
50N, 51N	Calculated Ground Overcurrent	2* / 1**	●
50G, 51G	Measured Ground Overcurrent	2* / 1**	○
IH2	Adjustable Inrush Blocking	1* / 1**	●
EXT	External Trip	1 (WIC1-1/2/3) 2 (WIC1-4)	○
46	Unbalanced Load	1*	○
51Q	Negative-Sequence Overcurrent	1*	○
49	Thermal Replica	1*	○
SOTF	Switch on to Fault	1*	○
	Peak Value Overcurrent (sample-based, very fast trip)	1* / 1**	○
CLPU	Cold Load Pickup	1 (WIC1-4)	○
Supervision	Description	Elements	
74TC	Trip Coil Monitoring		●
50BF	Circuit Breaker Failure (current-based)		●
WIC1-4 also 62BF	Circuit Breaker Failure (position-based)		○
	Breaker Wear		○
BP	Static Backup Overcurrent Protection		○
SBM ^(2.1)	Station Battery Monitoring ^(2.1)	(WIC1-4)	○
	Self-Supervision (State of health of the WIC1)		●

* = via DiggiMEC / Smart view
(2.0) = available as of Release 2.0.

** = via DIP/HEX switches
(2.1) = available as of Release 2.1

● = Standard

○ = Option

PROTECTION MADE SIMPLE.

Order Form WIC1

CT Powered Time Overcurrent and Ground Current Relay	WIC1	-	#	#	#	#	#	#	#	#	#	#
Mounting Form												
Settings via DiggiMEC / Smart view												
Settings via DIP switches, DiggiMEC / Smart view												
Settings via HEX switches, DiggiMEC / Smart view												
Dual-Powered, settings via DiggiMEC / Smart view												
CT Type												
Phase current measuring inputs for WIC1 CTs												
Earth Current Supervision												
Calculated earth current (**)												
Calculated or measured earth current (measuring inputs 1 A) (**)												
Nominal Frequency												
50 Hz (only WIC1-2, WIC1-3) (***)												
60 Hz (only WIC1-2, WIC1-3) (***)												
50 Hz / 60 Hz (only WIC1-1, WIC1-4) (***)												
Outputs												
Trip pulse output												
Trip pulse output, trip flag indicator												
Trip pulse output, assignable flag indicator												
Digital Inputs (only WIC1-1, WIC1-2, WIC1-3)												
No digital inputs												
External trip input (115 Vac or 230 Vac)												
1 assignable Digital Input (115 Vac or 230 Vac, flexible use, e. g. for external trip)												
Digital Inputs (only WIC1-4)												
No digital inputs												
External trip input, external reset input												
2 assignable Digital Inputs (flexible use, e. g. for Breaker Position)												
Backup Protection												
Backup protection operates directly												
Trip at 20·In,max												
Protection Packages												
ANSI 50/51, 50G/N, 51G/N, Inrush, 50BF, 74TC, Breaker Wear												
Package "S" + ANSI 46, 49, 51Q, Breaker Wear, Condition Monitoring (= Life Load, Peak Current Pointer)												
Package "A" + SOTF, CLPU(#), external protection(DI), ultra-fast overcurrent protection												
SCADA Communication (4)												
Without communication protocol												
Modbus RTU RS485 / terminals (4)												
Modbus TCP Ethernet 100 MB / RJ45 (4)												
Modbus TCP Optical Ethernet 100 MB / LC duplex connector (4)												

(4) = SCADA communication is available only for a WIC1-4 and can be used only with auxiliary power supply. Modbus RTU/RS485 available for WIC1-4 as of release 2.0, Modbus TCP available for WIC1-4 as of release 2.1.

(**) = The WIC1-4 is always delivered with ground current measuring input, i.e. option "N" is not available. However, via DiggiMEC or Smart view it is possible to configure any WIC1 variant (including WIC1-4) also for calculated ground current

(***) = Choice of nominal frequency (options "5" / "6") is relevant only for configuration via DIP/HEX switches (WIC1-2 / WIC1-3). Via DiggiMEC or Smart view, any WIC1 variant can be set to either 50 Hz or 60 Hz nominal frequency.

(#) = The Cold Load Pickup is available only for a WIC1-4 and can be used only with auxiliary power supply.

(DI) = External Protection cannot be available for the device variants without any Digital Input.

Order Form DiggiMEC®

Remote Display and Indication Unit for the WIC1	DiggiMEC	-#
Type		
Door mounting, 1 flag indicator, 1 bi-stable relay		
Door mounting, 3 flag indicators, 3 bi-stable relays		
Available Menu Languages		
English / German (1)		

* = WIC1/DiggiMEC only English, English/German using Smart view.

HEADQUARTERS:

SEG Electronics GmbH

Krefelder Weg 47
47906 Kempen
Germany

Sales

Phone: +49 (0) 21 52 145 331
Fax: +49 (0) 21 52 145 354
E-Mail: sales@SEGelectronics.de

Service & Support

Phone: +49 (0) 21 52 145 600
Fax: +49 (0) 21 52 145 354
E-Mail: support@SEGelectronics.de

Find Your Local Distributor on

<http://www.SEGelectronics.de>

Technical Documents:

<https://docs.SEGelectronics.de/wic1>



For more information please contact:

© SEG Electronics GmbH
www.SEGelectronics.de
All Rights Reserved | 07/2023