

MANUAL

WI Line | PROTECTION TECHNOLOGY
MADE SIMPLE

WIB1 | CT POWERED TIME OVERCURRENT AND
EARTH CURRENT RELAY



CT POWERED TIME OVERCURRENT AND EARTH CURRENT RELAY

Original document

English

Revision: N

Contents

1.	Comments on the manual	4
1.1	Information Concerning Liability and Warranty.....	4
1.2	IMPORTANT DEFINITIONS.....	5
1.3	Electrostatic Discharge Awareness.....	6
1.4	Safety Information.....	7
2.	Introduction	8
2.1	How to use this instruction.....	8
2.2	Introductory remarks on the WIB1.....	8
2.3	Product description	9
3.	Handling, Installation and Outside Dimensions.....	10
3.1	General information	10
3.1.1	Upkeep of the relay.....	10
3.1.2	Storage	10
3.1.3	Electrostatic discharge.....	10
3.2	Installation of the relay	10
3.3	Outside dimensions	11
3.4	Connection Diagram.....	11
4.	Operating instructions	14
4.1	General information on the WIB1	14
4.2	User interface	15
4.2.1	WIB12PE	15
4.2.2	WIB12FE.....	16
4.2.3	WIB12PEB.....	17
4.3	CTs for the WIB1	18
5.	Technical Data, Characteristics and Features.....	19
5.1	Protective functions	19
5.1.1	Minimal operating current and rated primary current.....	19
5.1.2	Phase time over current protection.....	20
5.1.3	Blocking stage.....	21
5.1.4	Earth current protection	22
5.2	Default Settings	23
5.2.1	WIB12FE und WIB12PE.....	23
5.2.2	WIB12PEB.....	23
5.3	Routine safety check (only WIB12PE).....	23
5.4	Fault value memory	23
5.5	Communication.....	24
5.5.1	Communication via PC adapter.....	24
5.5.2	WIC1PC2 Adapter	24
5.5.3	WIC1PC3 Adapter	24
5.6	Inputs and outputs	24
5.6.1	Remote trip input	25
5.6.2	Impulse output for the tripping coil.....	25
5.6.3	Impulse output for the flag indicators.....	25
5.6.4	Earthing.....	25
5.7	Technical Data.....	26
5.7.1	Common Data.....	26
5.7.2	Temperature Range.....	26
5.7.3	Accuracy (acc. to IEC60255-151).....	26
5.7.4	Time Accuracy (acc. to IEC60255-151).....	26
5.8	Design standards:.....	27
5.8.1	High voltage tests:	27
5.8.2	EMC immunity tests:.....	28
5.8.3	EMC emission tests:	28
5.8.4	Safety-Related Tests	29
5.8.5	Mechanical tests:	29
5.8.6	Environmental tests:	30

- 5.8.7 Outside dimension of CTs31
- 5.9 Characteristics and times33
 - 5.9.1 Characteristic curves33
 - 5.9.2 Calculation formula for IMT characteristics35
 - 5.9.3 Trip coil output36
 - 5.9.4 Flag Indicators36
- 5.10 Description of application37
 - 5.10.1 Foreword37
- 5.11 Selection of the CT transformation voltage ratio38
- 5.12 Adjustment instruction for inverse characteristic39
- 6. Commissioning and Maintenance 42**
 - 6.1.1 Important note 42
 - 6.2 Accessories for commissioning work42
 - 6.3 Criteria to be taken into account for protection devices fed by CT's42
 - 6.4 Special features for the WIB1 test43
 - 6.5 Selection of the secondary test system43
 - 6.6 Checks during commissioning43
 - 6.6.1 Wiring checks43
 - 6.6.2 WIB1 adjustment44
 - 6.7 Functional Test44
 - 6.7.1 Test Currents45
 - 6.7.2 Switching points for the overcurrent steps $I>$ 45
 - 6.7.3 Switching points for the short-circuit steps $I>>$ (only WIB12FE and WIB12PE)46
 - 6.7.4 Switching points for the blocking function steps I_{BLOCK} (only WIB12PEB)46
 - 6.8 Special features for earth current tests47
 - 6.8.1 Switching points for the earth current step $I_E>$ 47
 - 6.8.2 Switching points for the earth current short-circuit step $I_E>>$ 47
 - 6.9 Test procedure by way of example48
 - 6.10 Maintenance50
 - 6.10.1 Faults50
 - 6.10.2 Repair work50
- 7. Product Specific Features 51**
 - 7.1 Assignment of terminals51
 - 7.1.1 Assignment of terminals at WIB12PE and WIB12PEB51
 - 7.1.2 Assignment of terminals at WIB12FE51
 - 7.1.3 Earthing51
 - 7.2 Current transformer52
- 8. Annex 54**
 - 8.1 Dimensional drawing relay54
 - 8.2 Dimensional drawing flag indicator54
 - 8.3 Order form55
 - 8.4 Commissioning form56
 - 8.4.1 Parameter Setting WIB12FE and WIB12PE56
 - 8.4.2 Parameter Setting WIB12PEB56

SEG Electronics GmbH reserves the right to update any portion of this publication at any time. Information provided by SEG Electronics GmbH is believed to be correct and reliable. However, no responsibility is assumed by SEG Electronics GmbH unless otherwise expressly undertaken.

© 2022 SEG Electronics . All Rights Reserved.

1. Comments on the manual

This manual explains in general the tasks of device planning, parameter setting, installation, commissioning, operation and maintenance of the WIB1 device.

The manual serves as working basis for:

- Engineers in the protection field,
- commissioning engineers,
- people dealing with setting, testing and maintenance of protection and control devices,
- as well as trained personnel for electrical installations and power stations.

All functions concerning the type code will be defined. Should there be a description of any functions, parameters or inputs/outputs which do not apply to the device in use, please ignore that information.

All details and references are explained to the best of our knowledge and are based on our experience and observations.

This manual describes the (optionally) full featured versions of the devices.

All technical information and data included in this manual reflect their state at the time this document was issued. We reserve the right to carry out technical modifications in line with further development without changing this manual and without previous notice. Hence no claim can be brought based on the information and descriptions this manual includes.

Text, graphic and formulae do not always apply to the actual delivery scope. The drawings and graphics are not true to scale. We do not accept any liability for damage and operational failures caused by operating errors or disregarding the directions of this manual.

No part of this manual is allowed to be reproduced or passed on to others in any form, unless SEG Electronics *GmbH* have approved in writing.

This user manual is part of the delivery scope when purchasing the device. In case the device is passed on (sold) to a third party, the manual has to be handed over as well.

Any repair work carried out on the device requires skilled and competent personnel who need to be well aware especially of the local safety regulations and have the necessary experience for working on electronic protection devices and power installations (provided by evidence).

1.1 Information Concerning Liability and Warranty

SEG Electronics *GmbH* does not accept any liability for damage resulting from conversions or changes carried out on the device or planning (projecting) work, parameter setting or adjustment changes done by the customer.

The warranty expires after a device has been opened by others than SEG Electronics *GmbH* specialists.

Warranty and liability conditions stated in SEG Electronics *GmbH* *General Terms and Conditions* are not supplemented by the above mentioned explanations.

1.2 IMPORTANT DEFINITIONS

The signal definitions shown below serve the safety of life and limb as well as for the appropriate operating life of the device.



DANGER indicates a hazardous situation which, if not avoided, will result in death or serious injury.



WARNING indicates a hazardous situation which, if not avoided, could result in death or serious injury.



CAUTION, used with the safety alert symbol, indicates a hazardous situation which, if not avoided, could result in minor or moderate injury.



NOTICE is used to address practices not related to personal injury.



CAUTION, without the safety alert symbol, is used to address practices not related to personal injury.

1.3 Electrostatic Discharge Awareness

CAUTION

All electronic equipment is electro static-sensitive, some components more than others. To protect these components from electro static damage, you must take special precautions to minimize or eliminate electrostatic discharges.

Follow these precautions when working with or near the control.

1. Before doing maintenance on the electronic control, discharge the static electricity on your body to ground by touching and holding a grounded metal object (pipes, cabinets, equipment, etc.).
2. Avoid the build-up of static electricity on your body by not wearing clothing made of synthetic materials. Wear cotton or cotton-blend materials as much as possible because these do not store static electric charges as much as synthetics.
3. Keep plastic, vinyl, and Styrofoam materials (such as plastic or Styrofoam cups, cup holders, cigarette packages, cellophane wrappers, vinyl books or folders, plastic bottles, and plastic ash trays) away from the control, the modules, and the work area as much as possible.
4. Do not remove any printed circuit board (PCB) from the control cabinet unless absolutely necessary. If you must remove the PCB from the control cabinet, follow these precautions:
 - Do not touch any part of the PCB except the edges.
 - Do not touch the electrical conductors, the connectors, or the components with conductive devices or with your hands.
 - When replacing a PCB, keep the new PCB in the plastic antistatic protective bag it comes in until you are ready to install it. Immediately after removing the old PCB from the control cabinet, place it in the antistatic protective bag.

1.4 Safety Information

DANGER



Ignoring the following safety messages can result in death or serious injury or physical damage.

DANGER



Only qualified electricians may install, commission, work or operate this device. All national standards – if applicable – must be followed.

DANGER



Even when the auxiliary voltage is switched off, it is likely that there are still hazardous voltages at the component connections.

Upon opening the device it is likely that some parts with high voltages become accessible. Touching these is dangerous to life.

The device must be carefully grounded. See 5.6.4 “Earthing”.

WARNING



The device contains components that are sensitive to electrostatic discharge. Therefore any unnecessary touching of electronic parts must be avoided. The terminal block for connection to the current transformers is not a shorting block. Therefore always short-circuit current transformers before loosening the terminals.

NOTICE



The WIB1 CT Powered Time Overcurrent and Earth Current Relay does not contain any parts that are serviceable or adjustable by the user.

The housing is hermetically sealed and cannot be opened without causing damage. For more information see 3.1 “General information”.

Any unauthorized opening of the device will void the warranty.

2. Introduction

SEG Electronics GmbH protection relays of the WI-LINE are offering time over current protective functions and earth fault protective functions in the well-proven technique for CT powered protection relays. As combination of a compact protection relay and related current transformers, the WIB1 system was especially developed for compact MV switchboards with circuit breakers.

2.1 How to use this instruction

In this instruction the technical description of all WIB1 versions is included. The user is given a comprehensive insight into the various applications, the selection, installation, setting of parameters and putting into operation of the WIB1.

This instruction is divided into the following sections:

Chapter 1;	Introduction
Chapter 2;	Handling, installation and outside dimensions
Chapter 3;	Operating instructions
Chapter 4;	Technical data, characteristics and features
Chapter 5;	Product specific features
Chapter 6;	Annex; Dimensional drawing and flag indicator, Order form and commissioning form



OUT-OF-DATE PUBLICATION

This publication may have been revised or updated since this copy was produced. To verify that you have the latest revision, be sure to check the SEG Electronics GmbH website:

<http://www.segelectronics.de>

If your publication is not there, please contact your customer service representative to get the latest copy.

2.2 Introductory remarks on the WIB1

The requirements on MS distribution stations with circuit breakers call for a robust protection relay which is optimized accordingly and an integral part of the respective switchboard. The WIB1 is a time over current relay SEG Electronics has developed specifically for such requirements. The WIB1 is a CT-powered protection relay with minimal space requirement which complies with the highest demands on a digital protection device. Simple but safe wiring, high electromagnetic interference immunity, uncomplicated adjustment and the ability to scale to different power quantities of the switchboard, helping the switchgear manufacturer to minimize costs. By developing the WIB1 we are also able to present a protective system with a guaranteed maintenance-free period of 25 years, the same as for the switchboard.

2.3 Product description

The WIB1 is a CT-powered protection relay with inverse time and definite time protection characteristics and is specifically designed for switchboards with CBs and small rated output currents.

Together the specific CTs and the WIC1 form a joint protective system. A low-energy coil is needed for realizing trip of the CB.

Parameter setting can be done in user-friendly ways. By means of casting all electronic components incl. the housing are safely protected against climatic and mechanic influences.

In the WIB1 the following protection functions are realized:

- 3 phase definite time over current and short-circuit protection with variable tripping times (ANSI 50/51)
- 3 phase over current protection with selectable inverse time characteristics and definite time short-circuit current element (ANSI 50/51)
- definite time earth over current and earth short-circuit protection by internal calculation (ANSI 50N/51N)
- earth over current protection with selectable inverse time characteristics and instantaneous short-circuit current element (ANSI 50N/51N)

- WIB1 is available in three different versions WIB12PE, WIB12PEB and WIP12FE.
- The -FE version has less functionality:
 - Fixed connectors instead of pluggable connectors
 - Without Routine safety check ($I >>$ backup protection)
 - No plug-in connectors for CT test windings on board
- The -PEB version has different functionality:
 - The 3 phase short-circuit element is not available
 - The complete tripping can be blocked by parameter I_{BLOCK} depending on input current
 - Without Routine safety check ($I >>$ backup protection)

3. Handling, Installation and Outside Dimensions

3.1 General information

3.1.1 Upkeep of the relay

As a rule protection relays are of robust construction and the WIB1 in particular allows operation under extreme environmental conditions. But despite these facts, the WIB1 should be handled with the necessary care during installation and commissioning. Immediately after receipt of the relay it should be checked for possible damage inflicted during transportation. Any transport damage has to be notified to the transport firm handling the consignment.

Those relays which are not installed immediately should be stored in their original package (styrofoam).

3.1.2 Storage

If the relay is not used directly it has to be stored in its original packing. Permissible temperatures during storing are -40°C up to $+85^{\circ}\text{C}$. The storage place should be dry.

3.1.3 Electrostatic discharge

The electronic components used in the relay react very sensitive to electrostatic discharge but they are absolute safely placed inside the plastic housing. Additionally all electronic components are well protected by means of casting. Hence it is practical impossible that components are damaged by ESD.

There are no settings or calibrating appliances inside the housing, which would call for opening the device by the user. The housing is hermetically sealed and cannot be opened without causing damage.

3.2 Installation of the relay

By using the three 7mm drill holes, the relay is directly mounted onto the mounting plate. Detailed drawing with all measurements can be found under chapter 8.1.

3.3 Outside dimensions

All WIB1 types are of standardized design.

Weight: 700 g
 Dimensions: (Width x Height x Depth) 125 x 170 x40 mm

3.4 Connection Diagram

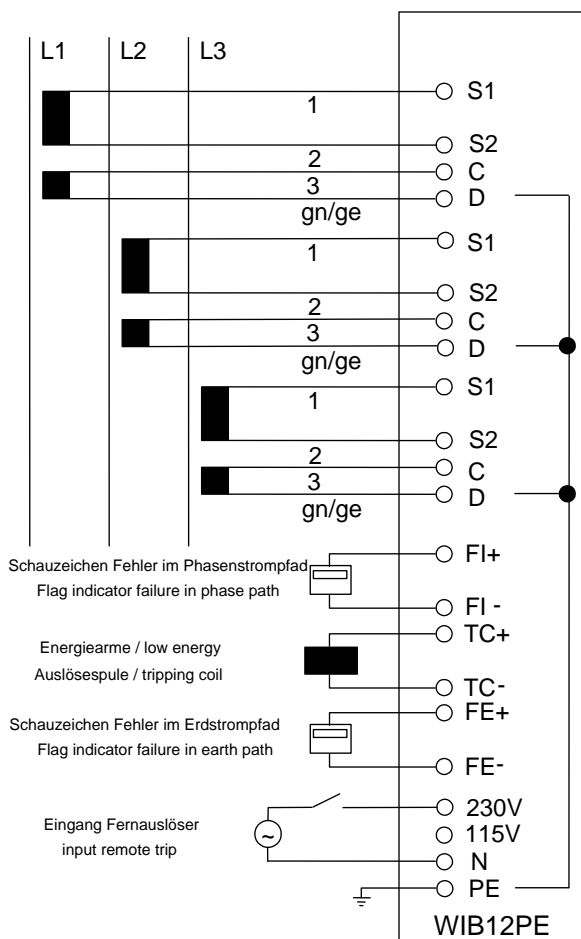

Figure 3.1: Connecting diagram WIB12PE and WIB12PEB

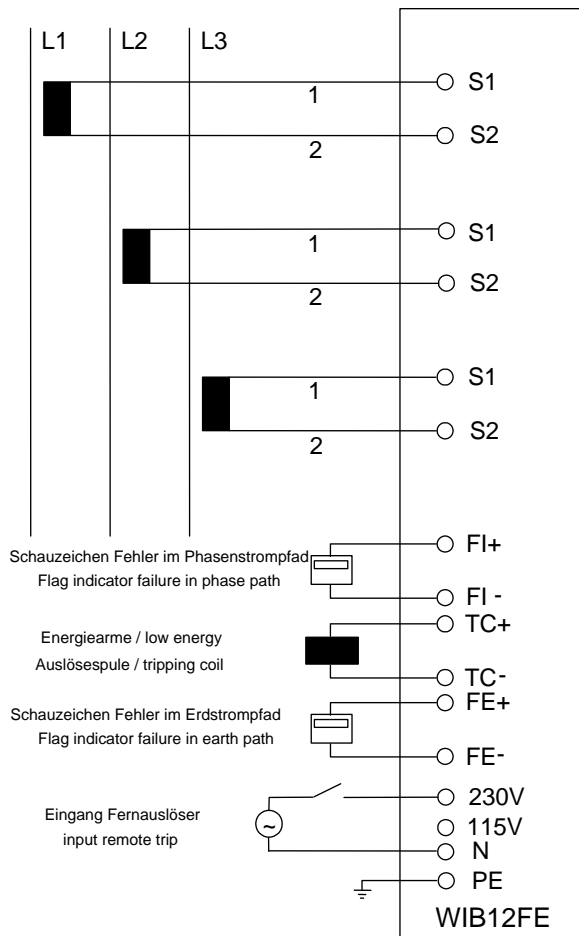

Figure 3.2: Connection diagram WIB12FE

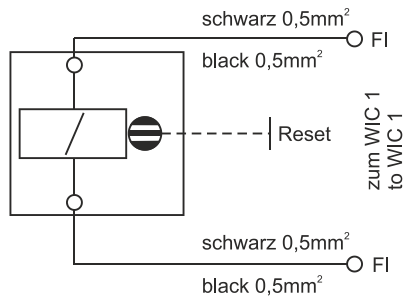

Figure 3.3 Connection diagram WI-SZ4 flag indicator

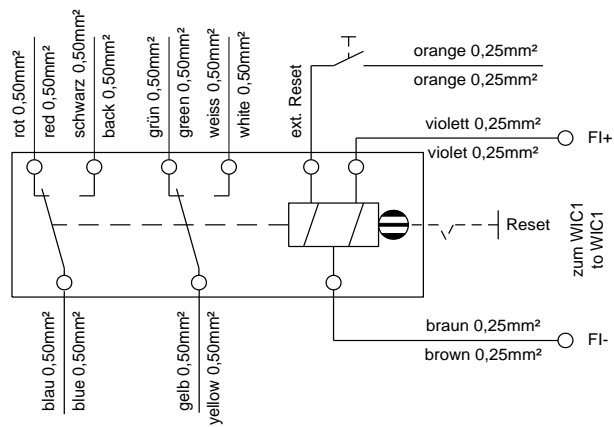

Figure 3.4 Connection diagram WI-SZ5 flag indicator

4. Operating instructions

4.1 General information on the WIB1

All available versions of the WIB1 relay are a high-tech and cost-optimized protection for MV switchboards.

Specifically in compact switchboards, the WIB12PE and WIB12FE protection system in combination with a circuit breaker can replace the combination of load-break-switch with HV fuses. Thereby in particular the overload protection for the attached unit is improved clearly.

When power distribution networks are extended more and more high powered transformers are used and here HV fuses are inadmissible. For such applications the WIB1 protection system is an optimal replacement.

If in special applications a breaker is used in combination with HV fuses the WIB12PEB functions as over current and earth current protection device in combination with the breaker. The short circuit protection is done by the HV fuses. To protect the breaker from damage by switching too high currents the WIB12PEB has a settable current level blocking the WIB12PEB from trip.

The WIB1 is provided with three analogue measuring inputs (3x phase current). The current measuring inputs are specially adjusted to the CTs allocated to the WIB1 protection system. There are 6 different CT ratios available for the protection system WIB1 which are conditional on the rated system current. The successive development towards the application time over current protection makes the system very user friendly. Reading of tripping values is done via the integrated interface. For this the user has one PC adapter and the software "WI-Soft2" at hand. The software is available for installation on a WINDOWS PC.

Setting of protection parameters is done by means of DIP switches

Cumulative current formation for earth current detection is programmed in the relay. The earth current is calculated from the three phase currents.

The WIB1 is provided with an input for remote tripping to which 115 VAC or 230 VAC can be connected. Tripping is realized via the electric impulse output, see 5.6.1 "Remote trip input".

A mechanical flag indicator WI1SZ4 can be installed for optical signaling occurrence of trip conditions. Trip conditions are phase fault or earth fault and can be indicated separately.

Furthermore it is possible to signal the trip events potentially free via the flag indicator WI1-SZ5. For this purpose the flag indicator is equipped with two changeover contacts.

The activation of the relay is signaled by a LED which is above the switches and protected by the clear plastic cover.

4.2 User interface

The adjustment of protective functions can be done via DIP switches;
 The setting of parameters via interface is not possible, but it is possible to read-out the stored fault values as well as the setting values.

The interface for this version can be found at the left of the relay and additionally above the DIP switch block.

4.2.1 WIB12PE

Switch No.	Setting parameter
1-1 – 1-3	I _S : Rated CT current
1-4 – 1-5	Choice of characteristics for phase path
1-6 – 2-1	I _{>} : Pick-up value of the definite time over current element or start value of the inverse time characteristic.
2-2 – 2-4	t _{>} : Tripping time of the definite time over current element or factor “a” of the inverse time characteristic
2-5 – 2-8	I _{>>} : Pick-up value of the short-circuit element
3-1 – 3-4	t _{>>} : Tripping time of the short-circuit element
3-5 – 3-6	Choice of characteristics for earth path
3-7 – 4-2	I _{E>} : Pick-up value of the definite time earth over current element or start value of the inverse time characteristic.
4-3 – 4-5	t _{E>} : Tripping time of the definite time earth over current element or factor “a” of the inverse time characteristic.
4-6 – 4-8	I _{E>>} : Pick-up value of time earth short circuit current element

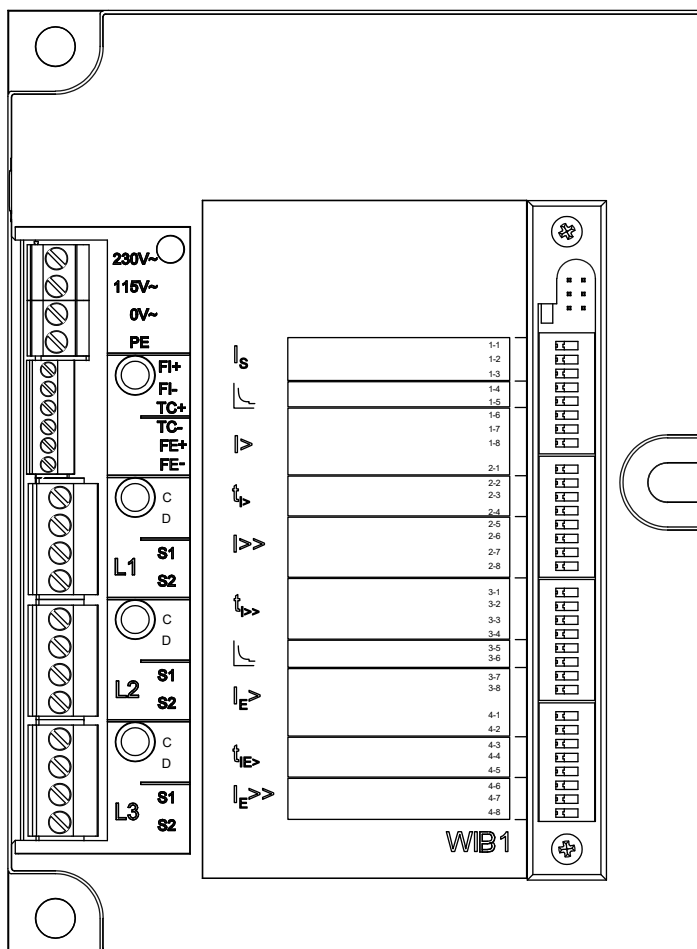

Figure 4.1: Front view WIB12PE

4.2.2 WIB12FE

Switch No.	Setting parameter
1-1 – 1-3	I _S : Rated CT current
1-4 – 1-5	Choice of characteristics for phase path
1-6 – 2-1	I _{>} : Pick-up value of the definite time over current element or start value of the inverse time characteristic.
2-2 – 2-4	t _{>} : Tripping time of the definite time over current element or factor “a” of the inverse time characteristic
2-5 – 2-8	I _{>>} : Pick-up value of the short-circuit element
3-1 – 3-4	t _{>>} : Tripping time of the short-circuit element
3-5 – 3-6	Choice of characteristics for earth path
3-7 – 4-2	I _{E>} : Pick-up value of the definite time earth over current element or start value of the inverse time characteristic.
4-3 – 4-5	t _{E>} : Tripping time of the definite time earth over current element or factor “a” of the inverse time characteristic.
4-6 – 4-8	I _{E>>} : Pick-up value of time earth short circuit current element

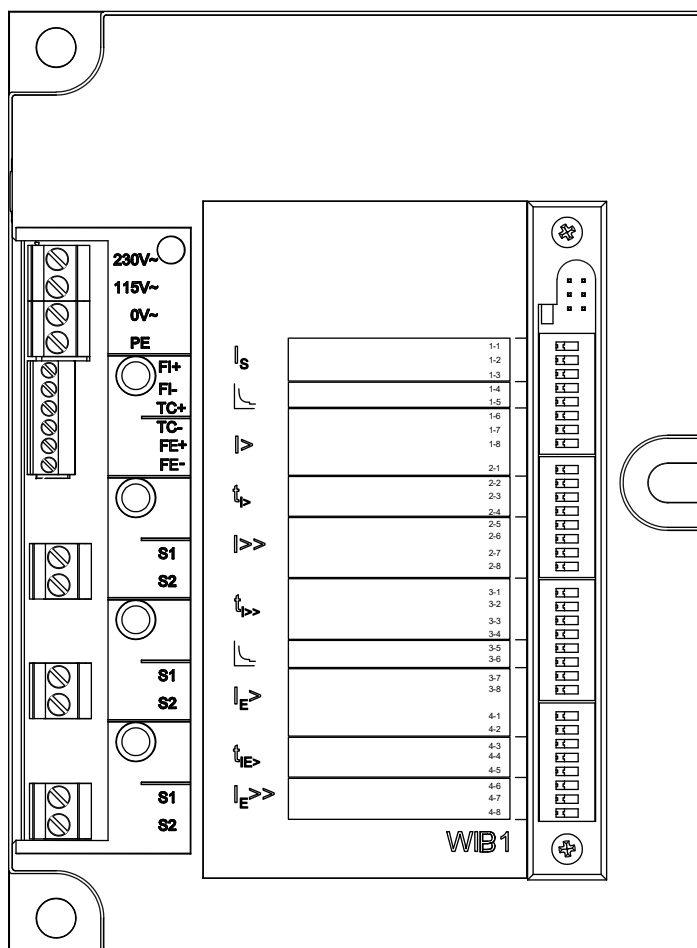

Figure 4.2: Front view WIB12FE

4.2.3 WIB12PEB

Switch No.	Setting parameter
1-1 – 1-3	I_S : Rated CT current
1-4 – 1-5	Choice of characteristics for phase path
1-6 – 2-1	$I_{>}$: Pick-up value of the definite time over current element or start value of the inverse time characteristic.
2-2 – 2-4	$t_{>}$: Tripping time of the definite time over current element or factor “a” of the inverse time characteristic
2-5 – 2-8	I_{BLOCK} : Pick-up value to block tripping
3-1 – 3-4	(Not used)
3-5 – 3-6	Choice of characteristics for earth path
3-7 – 4-2	$I_{E>}$: Pick-up value of the definite time earth over current element or start value of the inverse time characteristic.
4-3 – 4-5	$t_{E>}$: Tripping time of the definite time earth over current element or factor “a” of the inverse time characteristic.
4-6 – 4-8	$I_{E>>}$: Pick-up value of time earth short circuit current element

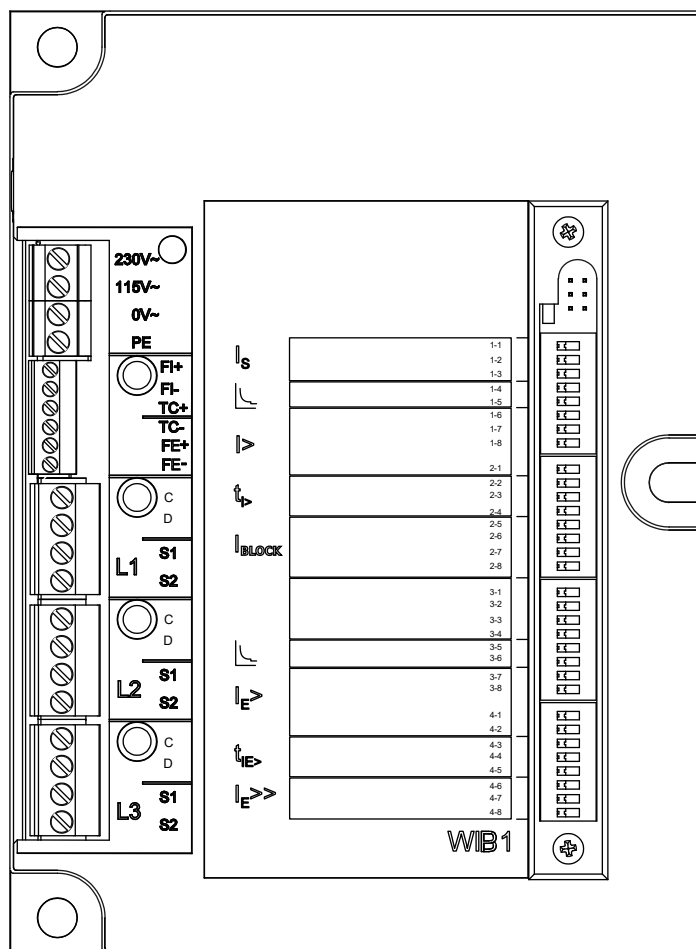

Figure 4.3: Front view WIB12PEB

4.3 CTs for the WIB1

There are six different wide-range CTs for the protection system WIB1. Dependent on the rated primary power and voltage of the system, the following CTs can be offered:

CT Type	Rated CT current IS
WIC1-WE2	16 – 30 A
WIC1-W2	16 – 30 A
WIC1-W3	32 – 60 A
WIC1-W4	64 – 120 A
WIC1-W5	128 – 240 A
WIC1-W6	256 – 480 A

The protection relay can be set to the respective operating current of the switchboard by parameter Is. Reference on the calculation of the protective setting values resulting from this is made in chapter "Description of Application".

Current transformer WIC1-WE2

In case of small values of the primary currents the user can choose for two current transformers with equal ratings but different characteristics of transmission, WE2 or W2.

It is typical reaction of self-powered protection relays such as WIB1 that there will be a non-linear transmission characteristic of the relay in case of small primary currents. This will affect the accuracy of the whole system if the current transformer is a W2 type and primary current values are less than 20 A.

In general, a worse accuracy can be accepted for phase current protection so that the CT W2 represents an inexpensive solution.

If there will be required a higher accuracy or in case of an active earth current protection element it is re-commended to use a WE2 mixed core type CT based on MU metal. In the lower operation range this CT type is more precise than the ordinary W2 type.

5. Technical Data, Characteristics and Features

5.1 Protective functions

5.1.1 Minimal operating current and rated primary current

In order to operate reliably, the WIB1 - as all CT-powered protection relays - needs a minimal current flowing constantly in one of the phases. This minimal current is the smallest rated CT current (I_s) x 0.9 listed in table.

The real rated current of the operating component to be protected is adjusted by parameter I_s . All further settings at the protection relay refer to the adjusted I_s . This is to be described in the following example;

Example for WIB12FE and WIB12PE:

Setting I_s = 40 A, CT type W3, 32 to 60 A
 Setting $I_{>}$: $1.1 \times I_s = 1.1 \times 40 \text{ A} = 44 \text{ A}$
 Setting $I_{>>}$: $10 \times I_s = 10 \times 40 \text{ A} = 400 \text{ A}$
 Setting $I_{E>}$: $0.2 \times I_s = 0.2 \times 40 \text{ A} = 8 \text{ A}$
 Setting $I_{E>>}$: $2 \times I_s = 2 \times 40 \text{ A} = 80 \text{ A}$

Example for WIB12PEB:

Setting I_s = 20 A, CT type W2, 16 to 30 A
 Setting $I_{>}$: $1.2 \times I_s = 1.2 \times 20 \text{ A} = 24 \text{ A}$
 Setting I_{BLOCK} : $8 \times I_s = 8 \times 20 \text{ A} = 160 \text{ A}$
 Setting $I_{E>}$: $0.4 \times I_s = 0.4 \times 20 \text{ A} = 8 \text{ A}$
 Setting $I_{E>>}$: $1 \times I_s = 1 \times 20 \text{ A} = 20 \text{ A}$

DIP switch 1-1 – 1-3: The following currents are adjusted by DIP switches:

DIP 1-1	OFF	ON	OFF	ON	OFF	ON	OFF	ON
DIP 1-2	OFF	OFF	ON	ON	OFF	OFF	ON	ON
DIP 1-3	OFF	OFF	OFF	OFF	ON	ON	ON	ON
WIC1-W2	16	18	20	22	24	26	28	30
WIC1-WE2	32	36	40	44	48	52	56	60
WIC1-W3	64	72	80	88	96	104	112	120
WIC1-W4	128	144	160	176	192	208	224	240
WIC1-W5	256	288	320	352	384	416	448	480

Table 5.1

NOTICE

*Note: All values are primary values in Ampere

5.1.2 Phase time over current protection

NOTICE

The min. tripping time when switched on to a failure is subject to the fault current level. See the following diagram. The diagram shows the tripping time under worst conditions like ageing, temperature.

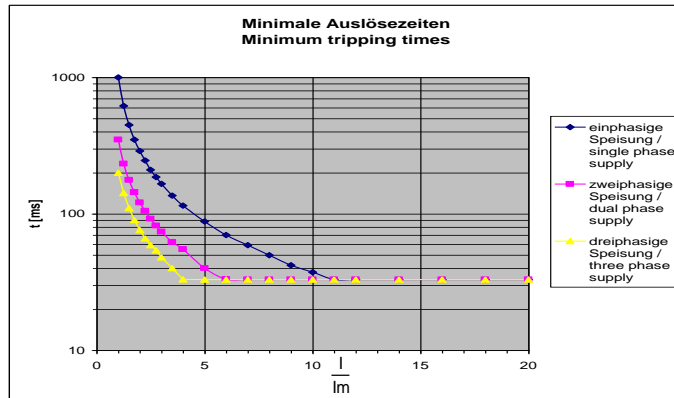

I_m = Minimum current

With the WIB1 protection system minimal tripping times of 40 ms can be achieved.

Time correction	of current 0	≤45 ms
	of current > I_m	≥35 ms
Disengaging time		<30 ms

The adjustment of values is done according to the tables listed below:

I_L Characteristic curve = DIP-Switch 1-4 – 1-5

DIP 1-4	OFF	ON	OFF	ON
DIP 1-5	OFF	OFF	ON	ON
Characteristic	DEFT	N-INV	V-INV	E-INV
	Phase path			

I_> = DIP-Switch 1-6 – 2-1

DIP 1-6	OFF	ON	OFF	ON	OFF	ON	OFF	ON	OFF	ON	OFF	ON	OFF	ON	OFF	ON
DIP 1-7	OFF	OFF	ON	ON	OFF	OFF	ON	ON	OFF	OFF	ON	ON	OFF	OFF	ON	ON
DIP 1-8	OFF	OFF	OFF	OFF	ON	ON	ON	ON	OFF	OFF	OFF	OFF	ON	ON	ON	ON
DIP 2-1	OFF	OFF	OFF	OFF	OFF	OFF	OFF	OFF	ON	ON	ON	ON	ON	ON	ON	ON
x Is	0.9	0.95	1	1.05	1.1	1.15	1.2	1.3	1.4	1.5	1.6	1.8	2	2.25	2.5	Exit

t_{I>} = DIP-Switch 2-2 – 2-4

DIP 2-2	OFF	ON	OFF	ON	OFF	ON	OFF	ON
DIP 2-3	OFF	OFF	ON	ON	OFF	OFF	ON	ON
DIP 2-4	OFF	OFF	OFF	OFF	ON	ON	ON	ON
time (s)	0.1	0.2	0.3	0.4	0.5	0.6	1	2
Factor "a"	0.05	0.1	0.2	0.3	0.4	0.6	0.8	1

I_{>>} = DIP-Switch 2-5 – 2-8 (only WIB12FE and WIB12PE)

DIP 2-5	AUS	EIN	AUS	EIN	AUS	EIN	AUS	EIN	AUS	EIN	AUS	EIN	AUS	EIN	AUS	EIN
DIP 2-6	AUS	AUS	EIN	EIN	AUS	AUS	EIN	EIN	AUS	AUS	EIN	EIN	AUS	AUS	EIN	EIN
DIP 2-7	AUS	AUS	AUS	AUS	EIN	EIN	EIN	EIN	AUS	AUS	AUS	AUS	EIN	EIN	EIN	EIN
DIP 2-8	AUS	AUS	AUS	AUS	AUS	AUS	AUS	AUS	EIN	EIN	EIN	EIN	EIN	EIN	EIN	EIN
x Is	1	2	3	4	5	6	7	8	9	10	12	14	16	18	20	EXIT

t_{I>>} = DIP-Switch 3-1 – 3-4 (only WIB12FE and WIB12PE)

DIP 3-1	OFF	ON	OFF	ON	OFF	ON	OFF	ON	OFF	ON	OFF	ON	OFF	ON	OFF	ON
DIP 3-2	OFF	OFF	ON	ON	OFF	OFF	ON	ON	OFF	OFF	ON	ON	OFF	OFF	ON	ON
DIP 3-3	OFF	OFF	OFF	OFF	ON	ON	ON	ON	OFF	OFF	OFF	OFF	ON	ON	ON	ON
DIP 3-4	OFF	OFF	OFF	OFF	OFF	OFF	OFF	OFF	ON	ON	ON	ON	ON	ON	ON	ON
time (s)	0,04	0,07	0,1	0,15	0,2	0,25	0,3	0,4	0,6	0,8	1,0	1,4	1,8	2,2	2,6	3,0

Information: At WIB12PEB HEX-Switch 6/DIP-Switch 3-1 – 3-4 is not used

5.1.3 Blocking stage

I_{BLOCK} = DIP-Switch 2-5 – 2-8 (only WIB12PEB)

DIP 2-5	AUS	EIN	AUS	EIN	AUS	EIN	AUS	EIN	AUS	EIN	AUS	EIN	AUS	EIN	AUS	EIN
DIP 2-6	AUS	AUS	EIN	EIN	AUS	AUS	EIN	EIN	AUS	AUS	EIN	EIN	AUS	AUS	EIN	EIN
DIP 2-7	AUS	AUS	AUS	AUS	EIN	EIN	EIN	EIN	AUS	AUS	AUS	AUS	EIN	EIN	EIN	EIN
DIP 2-8	AUS	AUS	AUS	AUS	AUS	AUS	AUS	AUS	EIN	EIN	EIN	EIN	EIN	EIN	EIN	EIN
x Is	1	1,5	2	3	4	5	6	7	8	9	10	12	14	16	18	20

5.1.4 Earth current protection

$I_{E_}$ Characteristic curve = DIP-Switch 3-5 – 3-6

DIP 3-5	OFF	ON	OFF	ON
DIP 3-6	OFF	OFF	ON	ON
Characteristic	DEF	N-INV	V-INV	E-INV
	Earth path			

$I_{E>}$ DIP-Switch 3-7 – 4-2

DIP 3-7	OFF	ON	OFF	ON	OFF	ON	OFF	ON	OFF	ON	OFF	ON	OFF	ON	OFF	ON
DIP 3-8	OFF	OFF	ON	ON	OFF	OFF	ON	ON	OFF	OFF	ON	ON	OFF	OFF	ON	ON
DIP 4-1	OFF	OFF	OFF	OFF	ON	ON	ON	ON	OFF	OFF	OFF	OFF	ON	ON	ON	ON
DIP 4-2	OFF	OFF	OFF	OFF	OFF	OFF	OFF	OFF	ON	ON	ON	ON	ON	ON	ON	ON
$x I_s$	0.2	0.3	0.4	0.5	0.6	0.7	0.8	0.9	1.0	1.2	1.4	1.6	1.8	2.0	2.5	Exit

$t_{IE>}$ = /DIP-Switch 4-3 – 4-5

DIP 4-3	OFF	ON	OFF	ON	OFF	ON	OFF	ON
DIP 4-4	OFF	OFF	ON	ON	OFF	OFF	ON	ON
DIP 4-5	OFF	OFF	OFF	OFF	ON	ON	ON	ON
time (s)	0.1	0.2	0.3	0.4	0.5	0.6	1	2
Factor "a"	0.05	0.1	0.2	0.3	0.4	0.6	0.8	1

$I_{E>>}$ DIP-Switch 4-6 – 4-8

DIP 4-6	OFF	ON	OFF	ON	OFF	ON	OFF	ON
DIP 4-7	OFF	OFF	ON	ON	OFF	OFF	ON	ON
DIP 4-8	OFF	OFF	OFF	OFF	ON	ON	ON	ON
$x I_s$	1	2	3	4	5	6	7	EXIT

$t_{IE>>}$ = 0.10 s (fixed)



Each earth current stage is blocked if actually measured phase current exceeds 20x set trip level:
 - The WIB don't trip at phase currents > 20x $I_{E>}$ when $I_{>}$, $I_{>>}$ and $I_{E>>}$ stages are disabled

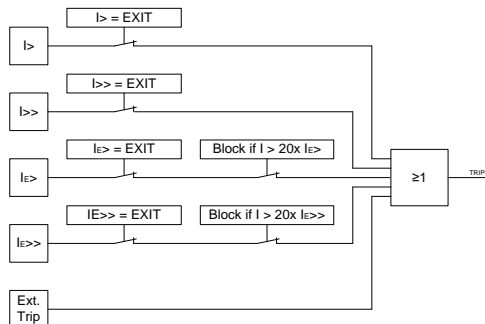

Figure 5.1: Trip logic WIB12FE und WIB12PE

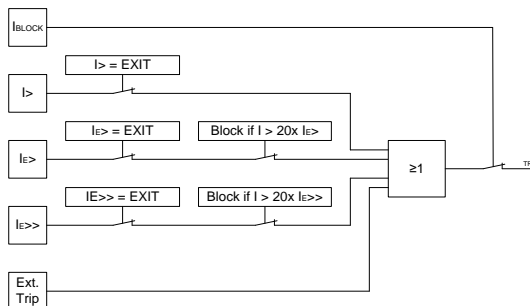

Figure 5.1.a: Trip logic WIB12PEB

The blocking function is implemented due to accuracy of earth current calculation in combination with the setting of each earth current element.

5.2 Default Settings

The WIB1 is set in our works at the smallest possible setting values.

5.2.1 WIB12FE und WIB12PE

I_s = smallest possible rated current

($W_2=16$ A, $W_3=32$ A, $W_4=64$ A, $W_5=128$ A, $W_6=256$ A)

Characteristic: Definite Time

$I_{>} = 0.9 \times I_s$

$I_{>} \text{ char} = \text{DEFT}$

$t_{I>} = 0.1$ s

$I_{>>} = 1.00 \times I_n$

$t_{I>>} = 0.04$ s

$I_{E>} \text{ char} = \text{DEFT}$

$I_{E>} = 0.20 \times I_s$

$t_{I_{E>}} = 0.10$ s

$I_{E>>} = 1 \times I_s$

$t_{I_{E>>}} = 0.10$ s (not adjustable)

5.2.2 WIB12PEB

I_s = smallest possible rated current

($W_2=16$ A, $W_3=32$ A, $W_4=64$ A, $W_5=128$ A, $W_6=256$ A)

Characteristic: Definite Time

$I_{>} = 0.9 \times I_s$

$I_{>} \text{ char} = \text{DEFT}$

$t_{I>} = 0.1$ s

$I_{\text{BLOCK}} = 1.00 \times I_n$

$I_{E>} \text{ char} = \text{DEFT}$

$I_{E>} = 0.20 \times I_s$

$t_{I_{E>}} = 0.10$ s

$I_{E>>} = 1 \times I_s$

$t_{I_{E>>}} = 0.10$ s (not adjustable)

5.3 Routine safety check (only WIB12PE)

A circuitry is integrated to give an additional back-up protection in case of processor or storage errors. By this circuitry a short-circuit protection with the following trip values is guaranteed:

- $I_{>>} = 20$ times highest rated CT current
- $t_{I_{>>}} = 40$ ms

5.4 Fault value memory

A fault value memory is integrated in the WIB1 where data of the latest fault occurrence is stored. The stored information can only be read out via the PC interface. The following fault references are available:

- the protective element causing the trip or an externally triggered trip
- values of the trip current in the individual phases and earth fault currents

5.5 Communication

5.5.1 Communication via PC adapter

For connection to the RS 232 interface of a PC, an adapter WIC1PC2 is needed.
For connection to the USB interface of a PC, an adapter WIC1PC3 is needed.

Through this adapter the galvanic isolation between protection device is reached and it supplies the WIB1 with the necessary energy. For communication a proprietary SEG Electronics protocol is used.

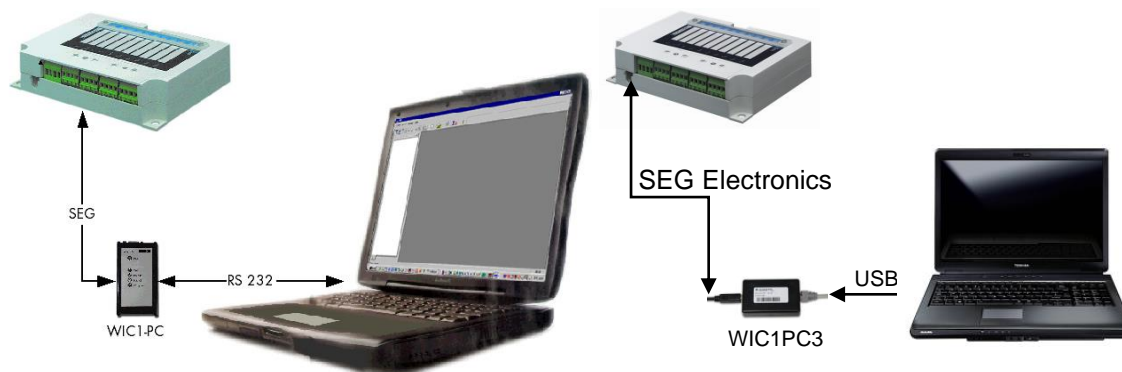

Figure 5.2: WIB1, WIC1-PC2 and Laptop

Abbildung 5.2a: WIB1, mit WIC1PC3 und Laptop

5.5.2 WIC1PC2 Adapter

To connect the WIC1PC2 to a RS232 interface, a 9-pole standard zero-modem-cable is needed. The cable is included in delivery of WIC1PC2
The lockable opening at the housing of WIB1 and the 6-pole plug are of matching design.

A 9V battery is integrated in the WIC1PC2 adapter. During reading out and writing of parameters the WIB1 is fed by the PC adapter

The battery charging level is indicated by LED on the PC adapter. As soon as the adapter is connected with the PC and the battery charging level is high enough, the LED lights up. Dropping of the battery voltage is indicated by LED.

The data exchange between PC/ and WIB1 is signaled by lighting up of the LED "Tx" and "Rx" resp. Transmit/Receive.

5.5.3 WIC1PC3 Adapter

To connect the WIC1PC3 to a USB interface, a USB cable with type A connector and type B connector is needed. The cable is included in delivery.

The USB port supplies the WIB1 via a DC/DC converter

5.6 Inputs and outputs

The terminals for connection of the CT, the tripping coil of the external trip input as well as the flag indicator output are provided at the left side of the WIB1. Screw-type terminals in 2, 4 or 6-block arrangement are used.

5.6.1 Remote trip input

Terminal PE is the central earthing point for the protective system. To the four terminals of the top terminal block 230V~; 115V~; 0V~ and PE the relevant aux. voltage for the remote trip input is connected. This input is electrically isolated. Terminal PE is the central earthing point for the protective system.

Technical Data:

Input voltage range: 230 V ± 15%
if operated above 2000 m (to max. 3000 m above sea-level): +13% / -15%

Tripping delay: 115 V ± 15%
≤ 1 s *

* The tripping time can be slightly longer for a cold restart of the WIB1 if an input voltage is fed in that is considerably below 115 V.



No flag indicator output is activated if the trip coil is triggered by this function.



**Only WIB12PEB:
In case of activated blocking function the remote trip input is also blocked.**

5.6.2 Impulse output for the tripping coil

The energy-low tripping coil of the circuit breaker is connected to terminals TC+ and TC- of the second terminal block. The trip energy is provided by a capacitor store integrated in the protection relay. Length of the trip impulse is 50 ms; the pause between the individual pulses depends on the impedance of the tripping coil and the current level. Pulsing is continued until the activation threshold is undershot.

Technical Data:

Trip energy: E ≥ 0.1 Ws
Voltage: ≥ 24 V DC



It is not allowed to connect any active voltage to the trip coil output

5.6.3 Impulse output for the flag indicators

Flag indicators can be connected to terminals FI+ and FI- or FE+ and FE- of the second terminal block. According to kind of failure in phase path or earth path the flag indicator FI+ and FI- or FE+ and FE- is energized. The trip energy is provided by a capacitor store integrated in the protection relay. The trip pulse for the flag indicators is generated in parallel to the trip coil trip pulse.

Technical Data:

Energy: E ≥ 0.01 Ws
Voltage: ≥ 24 V DC



It is not allowed to connect any active voltage to the flag indicator output

5.6.4 Earthing

The fourth terminal (PE) of the top terminal block is the central earth connection point of the protection system.

5.7 Technical Data

5.7.1 Common Data

Frequency:		45 Hz to 65 Hz
Nominal:		50/60 Hz
Thermal load capacity:		Permanently: 2.5 x highest rated CT current
	1s	25 kA CT primary current
	3s	20 kA CT primary current
Dynamic load capacity:		62.5 kA CT primary current

5.7.2 Temperature Range

Temperature range when stored:	-40°C to +85°C
Temperature range when in operation:	-40°C to +85°C

5.7.3 Accuracy

	(acc. to IEC60255-151)
Measuring accuracy (0° to 50°C):	≤ 5% (using CT WE1, WE2, W3, W4, W5 or W6)
	≤ 12.5% (input current 7.2 A to 10.0 A)
	≤ 7.5% (input current 10.0 A to 14.4 A)
	≤ 12.5% (input current 14.4 A to 20.0 A)
	≤ 7.5% (input current 20.0 A to 28.8 A)
	≤ 5% (input current > 28.8 A (using CT W2))
Calculated earth current (0° to 50°C):	≤ 7,5% of highest phase input current (using CT WE2, W3, W4, W5 or W6 (using W2 is not recommended with earth fault application))
Temperature influence:	≤ 2.5% within the range -40°C to 85°C
Disengaging ratio:	97,5% ± 2,5% of the pick-up value

5.7.4 Time Accuracy

	(acc. to IEC60255-151)
Threshold value of CHAR quantity:	1.1 x (Is x I>)
Effective range for CHAR:	1.1 to 20 x (Is x I>)
Phase DEFT Trip time:	±1% of the setting value ±10 ms
Phase CHAR Trip time:	based on current accuracy ±10 ms
Earth DEFT Trip time:	±1% of the setting value ±30 ms
Earth CHAR Trip time:	based on earth current accuracy ±30 ms
Trip time Limitation:	40 ms -6 ms/+10 ms for phase trip times 100 ms ± 30 ms for Earth trip times

Measuring- and trip delays are considered in trip time accuracy.

Trip times could be longer due to charging time of trip coil energy storage capacitors (see chapter 5.1.2)

The accuracies apply to all CT types available from the smallest adjustable primary currents up to a primary current of 20 x the highest rated CT current selectable.

CT Type	Applying Accuracy Measuring Range
WIC1-WE2	14.4 – 1152 A
WIC1-W2	14.4 – 1152 A
WIC1-W3	28.8 – 2304 A
WIC1-W4	57.6 – 4608 A
WIC1-W5	115.2 – 9216 A
WIC1-W6	230.4 – 18432 A

Table4.1 WIB1 measuring range

*Max. 20 x 14.4A

5.8 Design standards:

Generic standard	EN 61000-6-2 [2006], IEC 61000-6-2 Ed. 2.0 [2005] EN 61000-6-3 [2007], IEC 61000-6-3 Ed. 2.0 [2006]
Product standard	IEC 60255-6 Ed. 2.0 [1988] EN 50178 [1997]

5.8.1 High voltage tests:

Insulation voltage test

IEC 60255-27 [11/14]	All circuits to other circuits and exposed conductive parts	4 kV / 1 kV, 50 Hz, 1 min.
----------------------	---	----------------------------

Insulation resistance measurement

IEC 60255-5 Ed. 2.0 [2000]		>100MΩ
----------------------------	--	--------

Impulse voltage test

IEC 60255-27 [11/14]		7.2 kV / 5 kV / 1 kV, 0.5J, 1.2/50μs
----------------------	--	---

High frequency interference test

IEC 60255-22-1 Ed. 2.0 [2005] Class 3	Within one circuit	1kV / 2s
	Circuit to earth	2,5kV / 2s
	Circuit to circuit	2,5kV / 2s

5.8.2 EMC immunity tests:

Fast transient disturbance immunity test (Burst)

IEC 60255-22-4 Ed. 2.0 [2004]	Power supply, mains inputs	±4kV, 2,5kHz
IEC 61000-4-4 Ed. 2.0 [2004] Class 4	Other in- and outputs	±2kV, 5kHz

Electrical discharge immunity test

IEC 60255-22-2 Ed. 2.0 [1996]	Air discharge	8kV
IEC 61000-4-2 Ed. 1.2 [2001] Class 3	Contact discharge	6kV

Surge immunity test

IEC 61000-4-5 Ed. 2.0 [2005]	Within one circuit	2kV
IEC 60255-22-5 Ed. 1.0 [2002] Class 4	Circuit to earth	4kV

Radiated radio-frequency electromagnetic field immunity test

IEC 61000-4-3 Ed. 3.0 [2006] Class 3		10V/m
---	--	-------

Immunity to conducted disturbances induced by radio frequency fields

IEC 61000-4-6 Ed. 2.2 [2006] Class 3		10V
---	--	-----

Power frequency magnetic field immunity test

IEC 61000-4-8 Ed. 1.1 [2001] Class 5	Continues	100A/m
	3 sec.	1000A/m

5.8.3 EMC emission tests:

Radio interference suppression test

CISPR 11 Ed. 4.1 [2004]		Limit value class B
-------------------------	--	---------------------

Radio interference radiation test

CISPR 11 Ed. 4.1 [2004]		Limit value class B
-------------------------	--	---------------------

5.8.4 Safety-Related Tests

Overvoltage category:	IEC 60255-27 [11/14]	III
Pollution degree:	IEC 60255-27 [11/14]	3
Protection class:	IEC 60255-27 [11/14]	II
Test of withstand alternating voltage for 1 min:	IEC 60255-27 [11/14]	4 kV / 1 kV
Test of lightning surge voltage 1.2/50 μ s, 0.5 J	IEC 60255-27 [11/14]	7.2 kV / 5 kV / 1 kV
Inflammability:	IEC 60255-27 [11/14]	rated
Single Defect Condition:	IEC 60255-27 [11/14]	rated

5.8.5 Mechanical tests:

Vibration tests

IEC 60255-21-1 Ed. 1.0 [1988] Class 2	Vibration response test	0.075mm, 1g, 1 sweep cycle in each axis
	Vibration endurance test	2g, 20 sweep cycles in each axis

Shock- and bump tests

IEC 60255-21-2 Ed. 1.0 [1988] Class 2	Shock response test	10g, 11ms, 3 impulses in each direction
	Shock resistance test	30g, 11ms, 3 impulses in each direction
	Shock endurance test	20g, 16ms, 1000 impulses in each direction

5.8.6 Environmental tests:

Test Ad: Cold

IEC 60068-2-1 Ed. 5.0 [1990]	Temperatur / Temperature	-40°C
	Test duration	16h

Test Bd: Dry Heat

IEC 60068-2-2 Ed. 4.0 [1974]	Temperature	85°C
	Relative humidity	<50%
	Test duration	72h

Test Cab: Damp Heat (steady state)

IEC 60068-2-78 Ed. 1.0 [2001]	Temperature	40°C
	Relative humidity	93%
	Test duration	56 Days

Test Db: Damp Heat (cyclic)

IEC 60068-2-30 Ed. 3.0 [2005]	Temperature	85°C
	Relative humidity	95%
	Cycles (12 + 12-hour)	2

Class of protection

Relay housing	IP 40
Electronics	IP65
Terminals	IP20

5.8.7 Outside dimension of CTs

The structural forms of the CTs depend on the switchboard construction, i.e. they are in compliance with specific customer needs. We have various standard designs. For further information please contact your sales partner.



The current transformers shown below are dimensioned for nominal voltages <1000 V. This means, for application in MV-switchboards <36 kV these current transformers may only be used with insulated primary conductors for example cables with appropriate insulation resistance against earth. These current transformers are not allowed to be used for non-insulated primary conductors >1000 V against earth.

Type: WIC1-WxAS1



The diameter A of the CT hole is 50 mm at types WIC1W2AS1 to WIC1W5AS1

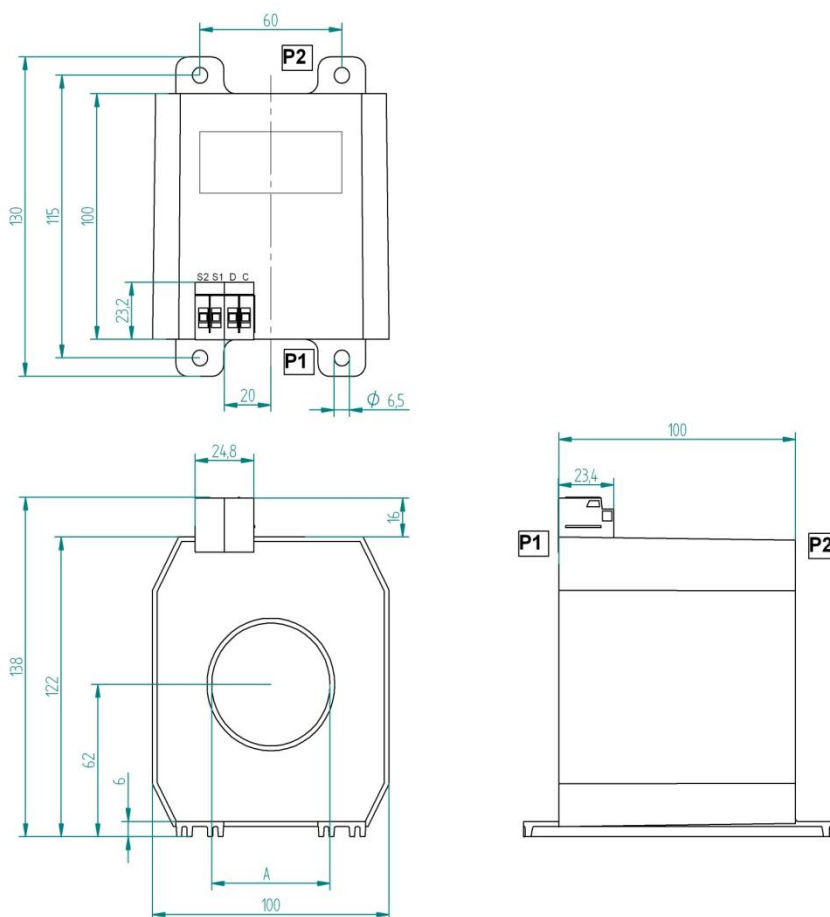

Figure 5.21: Type WIC1-W2AS1 – WIC1-W5AS1 as panel mounting

Type: WIC1-W6AS1

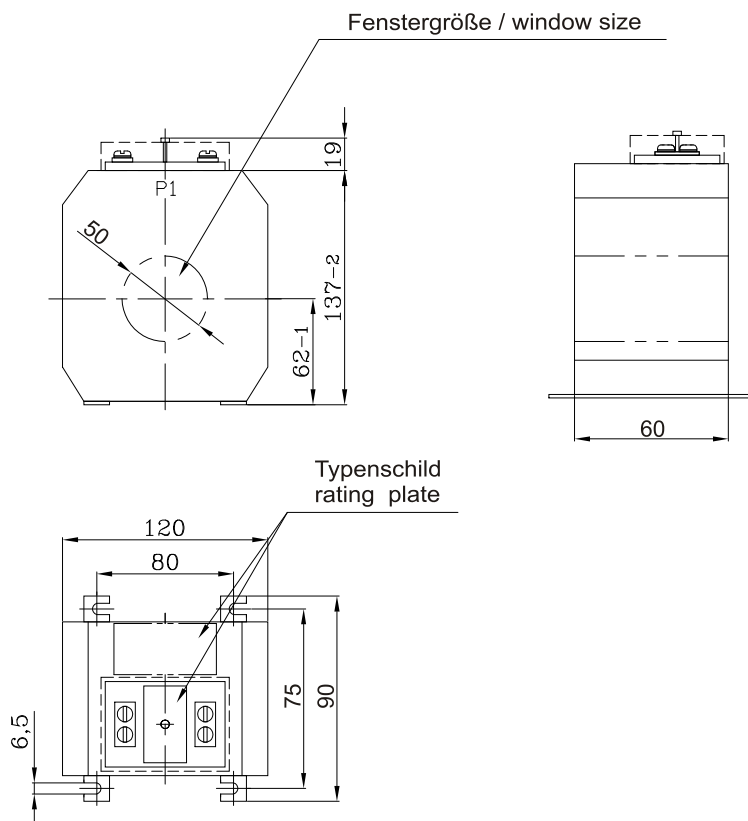

Figure 5.3: Type WIC1-W6AS1 as panel mounting

Type WIC1-WxH2

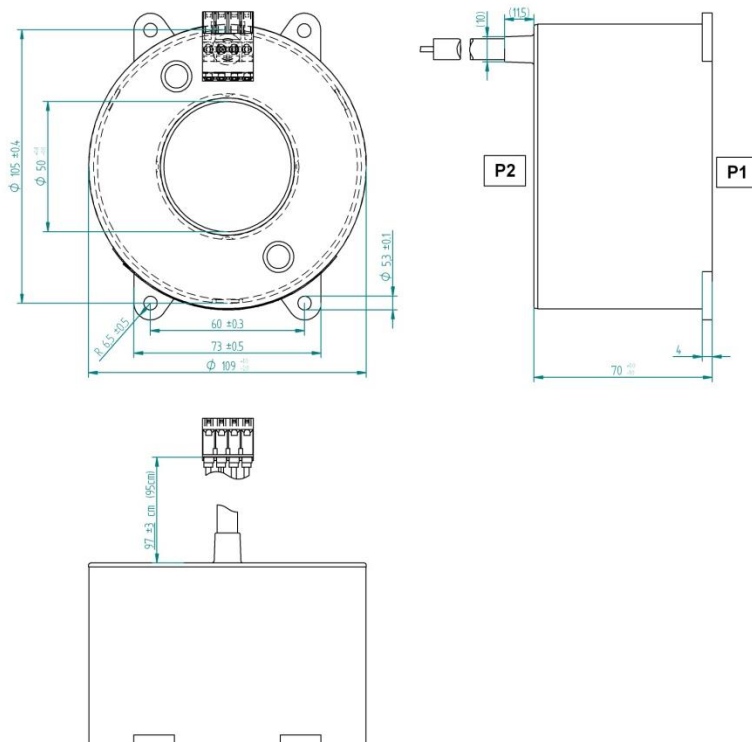

Figure 5.4: Type WIC1-W2H1 - WIC1-W6H1 as plug on type

5.9 Characteristics and times

5.9.1 Characteristic curves

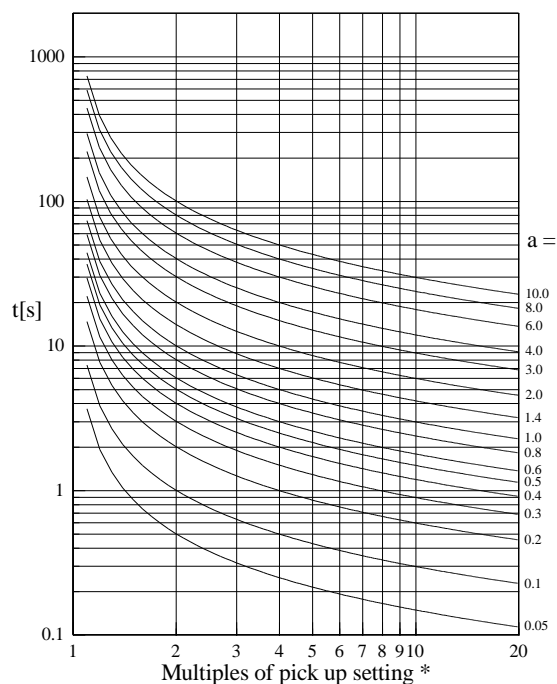

Figure 5.2: Normal Inverse

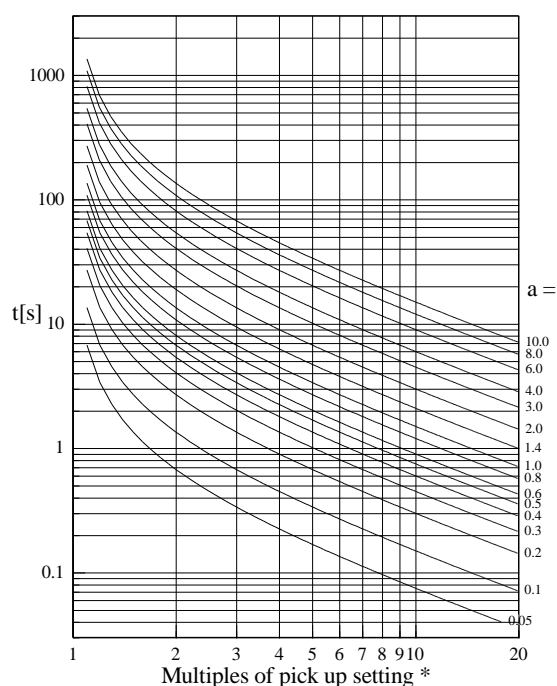

Figure 5.3: Very Inverse

NOTICE

*Multiples of pick up setting = $I_s \cdot I >$

For inverse characteristics please note that the factor 'a' is valid from 0.05 to 1 in WIB1 relay

CAUTION

Please note that the time characteristics used in earth path is limited to 100ms

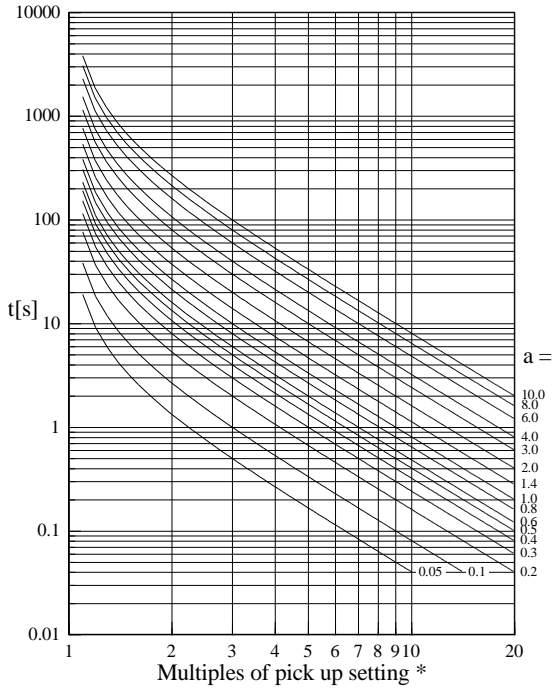

Figure 5.4: Extremely Inverse

NOTICE

NOTICE

** The starting point of the characteristic should be in the area of the rated CT current , e. g. W2 = 16 – 30 A (Is) and the over current parameter I> should not set higher than 1.8 x Is. If over the parameter I> the starting point is set higher, then the relay cut the characteristics at 20 x upper rated current.

*Multiples of pick up setting = Is * I>

For inverse characteristics please note that the factor 'a' is valid from 0.05 to 1 in WIB1 relay

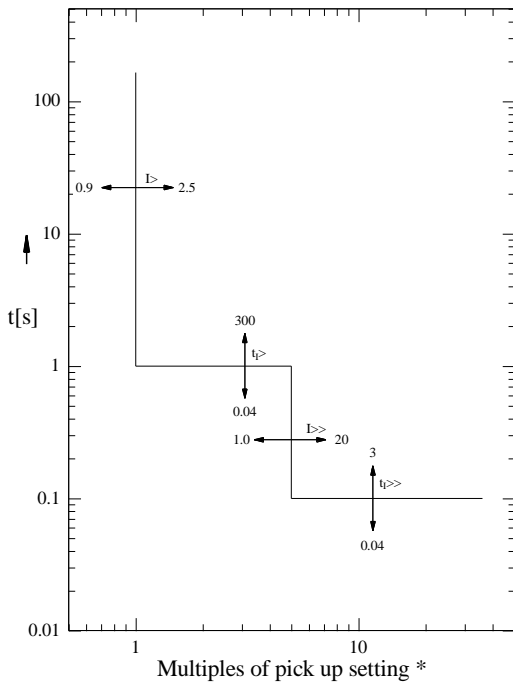

Figure 5.5: Definite Time

CAUTION

Please note that the time characteristics used in earth path is limited to 100ms

5.9.2 Calculation formula for IMT characteristics

Normal Inverse:

$$t = \frac{0.14}{\left(\frac{I}{I_s \times I_s}\right)^{0.02} - 1} \cdot a[s]$$

Very Inverse:

$$t = \frac{13.5}{\left(\frac{I}{I_s \times I_s}\right) - 1} \cdot a[s]$$

Extremely Inverse:

$$t = \frac{80}{\left(\frac{I}{I_s \times I_s}\right)^2 - 1} \cdot a[s]$$

5.9.3 Trip coil output

Trip coil output can be used with different type of trip coils

Trip energy: $E \geq 0.1 \text{ Ws}$
 Voltage: $\geq 24 \text{ V DC}$

Recommended minimum trip coil resistance: 4.3 Ohm at +20°C

5.9.4 Flag Indicators

WI1-SZ4

Technical Data

Coil: 24V DC $\pm 10\%$

- can be set electrically
- can be reset mechanically

Connector assignment

Coil connection	Core color	mm ²	Function
	black	0.25	Gnd/Set
	black	0.25	Gnd/Set

Cable connection length: 1 m

WI1-SZ5:

Technical Data

Coil: 24V DC $\pm 10\%$
 Contact rating: 230V AC/3 A
 230V DC/0.12 A
 115V DC/0.2 A
 24V DC/2 A

- Flag indicator with two potential free contacts
- can be set and reset electrically
- can be reset mechanically

Connector assignment:

Coil connection	Core color	mm ²	Function
	brown	0.25	(-) Gnd
	violet	0.25	(+) Set
	orange	0.25	(+) Reset
changeover contact 1	white	0.50	NO contact
	yellow	0.50	changeover contact
	green	0.50	NC contact
changeover contact 2	black	0.50	NO contact
	blue	0.50	changeover contact
	red	0.50	NC contact

Cable connection length: 1 m

5.10 Description of application

5.10.1 Foreword

As CT-powered protection relay the WIB1 is mainly used in MV switchboards with circuit breakers, protecting distribution transformers in local and industrial networks. Due to its small size the WIC1 is very well suited for the use in compact switchboards.

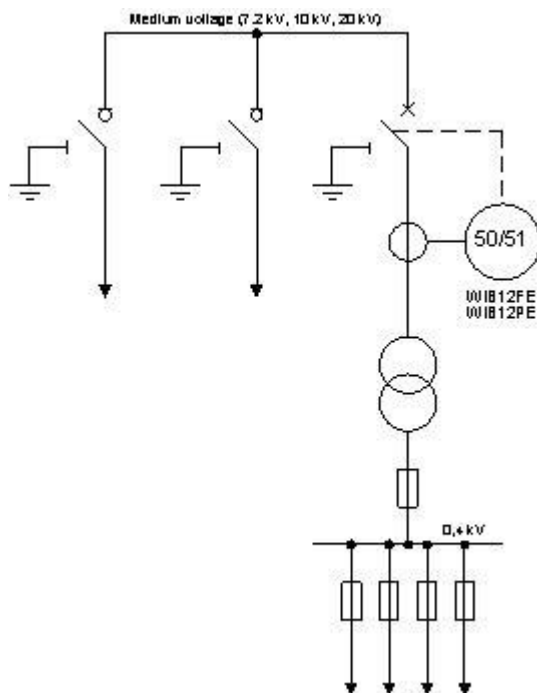

Figure 5.8: Basic circuit diagram of a standard switchboard with 2 feeders, circuit breaker and 1 outgoing transformer panel

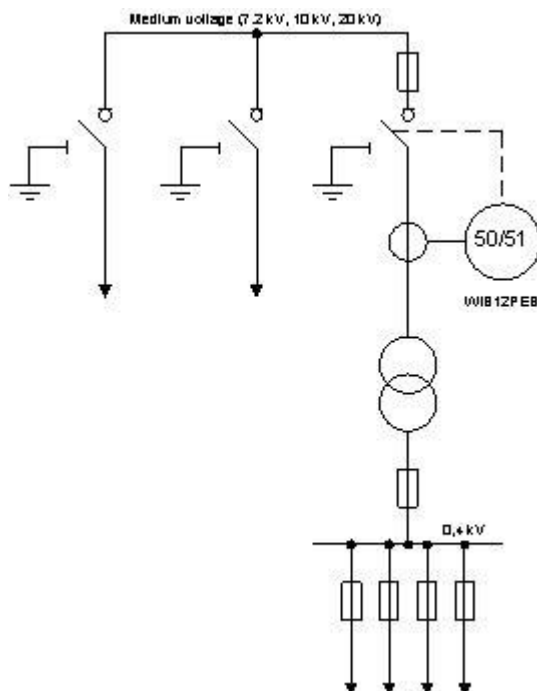

Figure 5.9: Basic circuit diagram of a standard switchboard with 2 feeder, load break switch, fuse and 1 outgoing transformer panel

The ability of the protection system WIB1 to adapt to different primary currents makes it possible that it is used for all standard rated transformer loads and the different MV operational voltages.

5.11 Selection of the CT transformation voltage ratio

Selection of the CT suitable for the WIB1 depends on the rated current of the transformer to be protected and is calculated acc. to the following formula:

Example:

SN = 1600 kVA

UN = 10 kV

-> $I_N = 92.5 \text{ A}$

CTs WIC1-W3 and WIC1-W4 are suitable for this rated current.

Marginal conditions, which should be regarded additionally with the selection of the CT's.

1. Short-circuit transient characteristic
The WIB1 can measure a short-circuit current of a circuit up to 20 times of the upper rated CT current. This means for the CT selected above, W3: $112 \text{ A} \times 20 = 2240 \text{ A}$ or, W4: $224 \text{ A} \times 20 = 4480 \text{ A}$. If the short-circuit current of a circuit is approx. 3 kA, for example, because of the location, then the preference should be given to the W4 CT, so that the current can be measured cleanly by the WIB1.
2. Operating current.
Furthermore please pay attention to the operating current of the protection object. The operating current should be in the rated CT current range. The WIB1 system can be loaded continuously up to 2.5 times of the upper rated CT current. This has no effect on the measurement of the overload. But due to the limitation of the measurement to 20 times the upper rated CT current, the short-circuit protection is limited.

With parameter Is the calculated rated current is preset in the protection relay.

According to table 4.1 IS currents of 88A can be adjusted for both CT types in WIB1

In the example shown below, the transformer can be operated with 1.1 times the rated current for 10s. The setting value for I> is calculated as follows:

$$I_{>} = \frac{1.1 \cdot I_{NT}}{I_S} = \frac{1.1 \cdot 92.5 \text{ A}}{88 \text{ A}} = 1.16 \cdot I_S$$

By means of the switches, however, only 1.15 x Is or 1.2 x Is can be set for parameter I>. Therefore it is up to the user to choose either 1.15 x Is or 1.2 x Is

The different rated primary currents of all standard transformer sizes at various rated mains voltages are compiled in chapter 7.2.

5.12 Adjustment instruction for inverse characteristic

In the introduction phase of the WIB1 it came to understanding problems during the adjustment of the protection relay, in particular when using inverse characteristics. In the following now the connections are for this described.

Notion definition:

I_s = Setting value of the load current

With the parameter I_s the operating current of the protected equipment is set. Due to the application of wide range CT's the use of only one CT for a wide primary current range is applicable. All further setting parameter are related to the parameter I_s .

$I_{>}$ = Pick up value of the overcurrent element / Starting point of an overcurrent characteristic

In case of a Definite Time characteristic this parameter sets the threshold value of the overcurrent element.

In case of an Inverse characteristic this parameter sets the starting point of a characteristic. Exceed the measured current the factor $I_s \times I_{>}$ the WIB1 will pick up.

$t_{>}$ = Delay time of the overcurrent element by use of DEFT

In case of a Definite Time characteristic this parameter sets the trip delay of the WIB1 after a pick up by $I_{>}$. The relay will trip, if the threshold $I_{>}$ is still exceeded when the delay timer $t_{>}$ has expired.

a = Time multiplier of the characteristic by the use of INV

In case of an Inverse characteristic, the trip delay is calculated based on the measured current and the chosen characteristic using the time multiplier "a". The relay will trip, if the threshold $I_{>}$ is still exceeded when the delay given by the characteristic has expired.

$I_{>>}$ = Pick up value of the short circuit element (only WIB12FE and WIB12PE)

With this parameter the threshold value of the short current element is set. Exceed the measured current the factor $I_s \times I_{>>}$ the WIB1 will pick up.

$t_{>>}$ = Tripping time of the short circuit element (only WIB12FE and WIB12PE)

This parameter sets the trip delay of the WIB1 after a pick up by $I_{>>}$. The relay will trip, if the threshold $I_{>>}$ is still exceeded when the delay timer $t_{>>}$ has expired.

I_{BLOCK} = Pick up value of the blocking function (only WIB12PEB)

With this parameter the pick-up value of the blocking function is set. Exceed the measured current the factor $I_s \times I_{BLOCK}$ the tripping of the WIB12PEB is blocked.

$I_{E>}$ = Pick up value of the earth overcurrent element / Starting point of an earth overcurrent characteristic

In case of a Definite Time characteristic this parameter sets the threshold value of the earth overcurrent element.

In case of an Inverse characteristic this parameter sets the starting point of a characteristic.

Exceed the measured current the factor $I_s \times I_{E>}$ the WIB1 will pick up.

 $t_{I_{E>}}$ = Delay time of the earth overcurrent element by use of DEFT

In case of a Definite Time characteristic this parameter sets the trip delay of the WIB1 after a pick up by $I_{E>}$. The relay will trip, if the threshold $I_{E>}$ is still exceeded when the delay timer $t_{I_{E>}}$ has expired.

 a = Time multiplier of the earth characteristic by the use of INV

In case of an Inverse characteristic, the trip delay is calculated based on the measured current and the chosen characteristic using the time multiplier "a". The relay will trip, if the threshold $I_{E>}$ is still exceeded when the delay given by the characteristic has expired.

 $I_{E>>}$ = Pick up value of the earth short circuit element

With this parameter the threshold value of the earth short circuit element is set.

Exceed the measured current the factor $I_s \times I_{E>>}$ the WIB1 will pick up.

 $t_{I_{E>>}}$ = Tripping time of the earth short circuit element

This parameter sets the trip delay of the WIB1 after a pick up by $I_{E>>}$. The relay will trip, if the threshold $I_{E>>}$ is still exceeded when the delay timer $t_{I_{E>>}}$ has expired. For WIB1 this time is set fix to 100 ms.

Estimation of the tripping time at inverse characteristics

The estimation of the tripping time by the use of an inverse characteristic will be explained at the following example.

Boundary condition:

Operating current of the load (I _s)	72 A
Selected CT ratio	WIB1-W4, 64 A – 120 A
Characteristic	Normal Inverse N-INV
Starting point of the characteristic	I _{>} x I _s
Over current (I _{>}):	1.4
Factor „a“ (tI _{>})	0.2
Short current (I _{>>})	1 kA
Delay time for I _{>>}	100 ms
Primary test current value	150 A

Setting of the WIB1:

I_s = 72 A
 I_> = 1.4
 „a“ (tI_>) = 0.2
 I_{>>} = 14 (1 kA/72 A = 13.88)
 t_{i>>} = 0.1 s

Estimation of the tripping time from the characteristic curve

Starting point of the curve = 1.4 x 72 A = 100.8 A, this correspond to = 1 x I/I_s x I_>.
 Primary testing current = 150 A, here for a factor as follows is calculated
 I/I_s x I_> = 150 A/100.8 A = 1.488

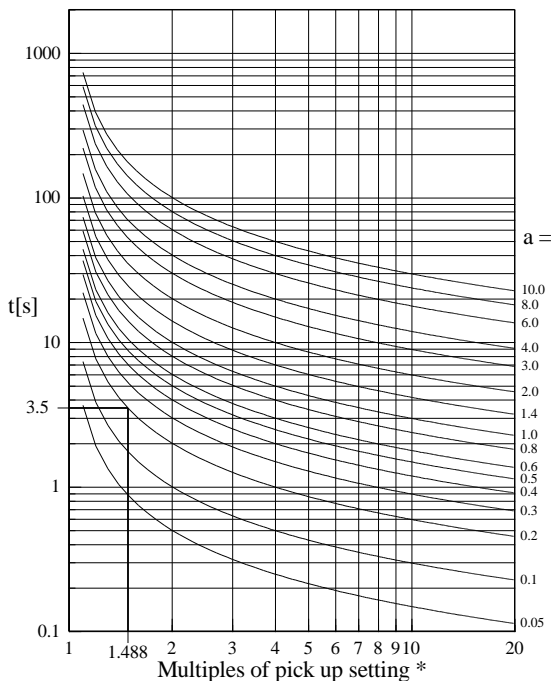

NOTICE

*Multiples of pick up setting =

From the curve a tripping time of 3.5 s is estimated.

NOTICE

For inverse characteristics please note that the factor 'a' is valid from 0.05 to 1 in WIB1 relay

6. Commissioning and Maintenance

The following information can only be used for commissioning and maintenance of WIB12PE version as a secondary test method. The WIB12FE can only tested with primary test method.

6.1.1 Important note



Putting into operation and the relevant tests should only be carried out by skilled personnel. We do not accept any liability for damage caused by improper handling of the protection system, or of the primary side of the equipment. Pay attention to check that over the primary circuit no second current flow way is possible. (Grounding of the feeder).

6.2 Accessories for commissioning work

For commissioning of the protection system the following accessories should be available:

- Secondary testing system (see chapter 5.3ff)
- Screwdriver; cross slot type, size 1; 3mm slot
- Setting parameters

6.3 Criteria to be taken into account for protection devices fed by CT's

With this kind of current supply it has to be taken into account that the CT has to feed more power than this is the case for protection devices with an additional aux. voltage source. Furthermore it has to be noted that – with reference to the entire measuring range of the protection devices – the input impedance of the individual phases is not linear. The necessary power for testing the WIB1 is shown on the following graphs.

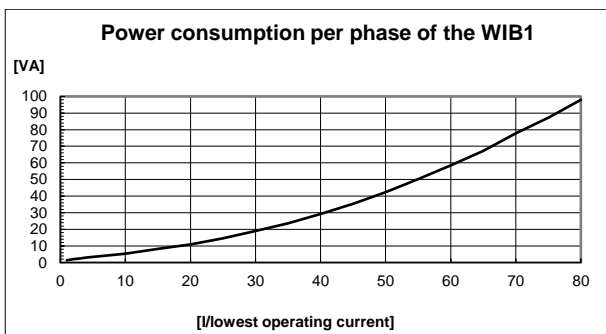

Figure 6.1: Power consumption of one phase over the entire measuring range of the WIB1

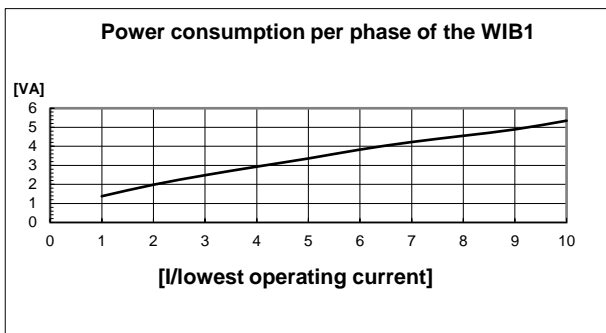

Figure 6.2: Power absorbed by one phase over the range 0.1 – 10 lowest operating current

Lowest operating current = lower rated current x 0,9. The operating current is chosen by $I_s * I >$.

Current transformer type

- WIC1-W2xx: 14.4 A ($I_s = 16$ A)
- WIC1-W3xx: 28.8 A ($I_s = 32$ A)
- WIC1-W4xx: 57.6 A ($I_s = 64$ A)
- WIC1-W5xx: 115.2 A ($I_s = 128$ A)
- WIC1-W6xx: 230.4 A ($I_s = 256$ A)

I_s = lowest rated current

6.4 Special features for the WIB1 test

The WIB1 receives its supply energy out of the measuring circuit. Conditional on the circuit logic the WIB1 changes its measuring load in a cyclic way and that in a 1 kHz cycle. This can have an effect on the feeding source.

6.5 Selection of the secondary test system

When selecting the secondary test system the following particulars should be taken into account.

- Secondary test system to be used as power source.
- Three phases for the earth current test, one phase for the phase current test (see chapter 5.8).
- Sufficient output power for the switching points to be tested (see fig. 5.1 and 5.2).
- The highest possible test current for testing via the test winding is at 22.4 amps. A test system with an output current up to 10 amps should be enough.
- A timer for measuring the time 0 – 300 s. The time signal can be measured via the WIB1 outputs TC+/TC- or FI+/FI- or FE+/FE- as positive edge of a 24 V signal.

6.6 Checks during commissioning

When putting into operation, the wiring and setting of the protection relay should be checked. Here the person doing the commissioning work is assisted by the integrated test windings of the WIB1 protection system, which are on the front of the relay. Hence any wiring jobs as well as actions in the cable connection area can be disregarded.

6.6.1 Wiring checks

Wiring has to be checked with the circuitry shown in the diagram below.

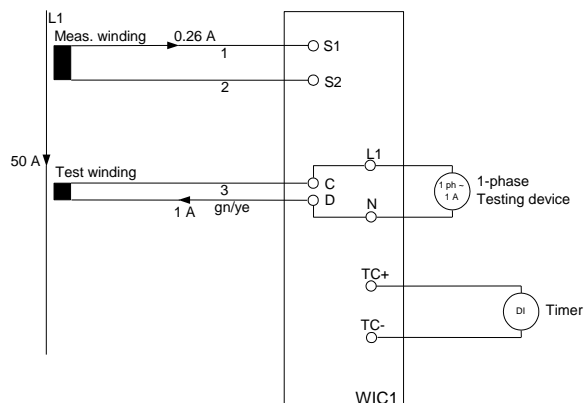

Figure 6.3: Connection of a single-phase testing device (phase L1) with CT WIC1-W2

The testing current is fed via sockets L1, L2, L3 and N. The test winding is rated such that the fed current of 1A balances a primary current of 50 A (CT type WIC1-W2). The timer should be connected in parallel to the tripping coil or the flag indicator. If there is no tripping coil or flag indicator available when the test is performed, an input resistor should be connected to the timer. The resistance of a timer should be in the range of 20 Ohm up to 1 kOhm. This prevents false measurements when tests are repeated in short intervals because the energy store cannot be discharged.

6.6.2 WIB1 adjustment

The protection parameters are to be adjusted according to chapter 4 of this instruction. The set parameters can be registered directly on the sticker affixed on the relay.

6.7 Functional Test

There are two methods to carry out the tests: Primary test and secondary test.

When the primary test method is used, the test current is impressed via the primary winding.

When the secondary test method is used, the test current is impressed via the CD test winding. There are eight different standard CT types available for the WIB1.

CT Type	Induced Current	Primary Current	Transformation Ratio
WIC1-WE2	1 A	50 A	50:1
WIC1-W2	1 A	50 A	50:1
WIC1-W3	1 A	100 A	100:1
WIC1-W4	1 A	200 A	200:1
WIC1-W5	1 A	400 A	400:1
WIC1-W6	1 A	800 A	800:1

6.7.1 Test Currents

The transformation ratio of primary currents to secondary currents of the CTs are equally proportionate as the test current via the CD winding to the secondary current. This means, no matter which CT type is in operation, for the secondary test always the same test values are used.

DIP 1-1	OFF	ON	OFF	ON	OFF	ON	OFF	ON	OFF	ON	OFF	ON	OFF	ON	OFF	ON
DIP 1-2	OFF	OFF	ON	ON	OFF	OFF	ON	ON	OFF	OFF	ON	ON	OFF	OFF	ON	ON
DIP 1-3	OFF	OFF	OFF	OFF	ON	ON	ON	ON	OFF	OFF	OFF	OFF	ON	ON	ON	ON
HEX switch position	0	1	2	3	4	5	6	7								
WIC1-W2	16	18	20	22	24	26	28	30								
Test current CD	0.32	0.36	0.40	0.44	0.48	0.52	0.56	0.60								
WIC1-W3	32	36	40	44	48	52	56	60								
Test current CD	0.32	0.36	0.40	0.44	0.48	0.52	0.56	0.60								
WIC1-W4	64	72	80	88	96	104	112	120								
Test current CD	0.32	0.36	0.40	0.44	0.48	0.52	0.56	0.60								
WIC1-W5	128	144	160	176	192	208	224	240								
Test current CD	0.32	0.36	0.40	0.44	0.48	0.52	0.56	0.60								
WIC1-W6	256	288	320	352	384	416	448	480								
Test current CD	0.32	0.36	0.40	0.44	0.48	0.52	0.56	0.60								

Table 6.1: Test values via CD winding with the different CT types

This means when I_s is multiplied with the setting value of the relevant protection element of $I>$, $I>>$ respectively I_{BLOCK} or $I_{E>}$ it equals the test current via the test winding. The CT type is of no consequence. The following tables show all setting values for the protection steps $I>$, $I>>$ respectively I_{BLOCK} and $I_{E>}$.

6.7.2 Switching points for the overcurrent steps $I>$

DIP 1-6	OFF	ON	OFF	ON	OFF	ON	OFF	ON	OFF	ON	OFF	ON	OFF	ON	OFF	ON
DIP 1-7	OFF	OFF	ON	ON	OFF	OFF	ON	ON	OFF	OFF	ON	ON	OFF	OFF	ON	ON
DIP 1-8	OFF	OFF	OFF	OFF	ON	ON	ON	ON	OFF	OFF	OFF	OFF	ON	ON	ON	ON
DIP 2-1	OFF	OFF	OFF	OFF	OFF	OFF	OFF	OFF	ON	ON	ON	ON	ON	ON	ON	ON
Setting value $I> + I_s$	0.90	0.95	1.00	1.05	1.10	1.15	1.20	1.30	1.40	1.50	1.60	1.80	2.00	2.25	2.50	EXIT
$I_s = \text{Hex „0“}$	0.288	0.304	0.320	0.336	0.352	0.368	0.384	0.416	0.448	0.480	0.512	0.576	0.640	0.720	0.800	-
$I_s = \text{Hex „1“}$	0.324	0.342	0.360	0.378	0.396	0.414	0.432	0.468	0.504	0.540	0.576	0.648	0.720	0.810	0.900	-
$I_s = \text{Hex „2“}$	0.360	0.380	0.400	0.420	0.440	0.460	0.480	0.520	0.560	0.600	0.640	0.720	0.800	0.900	1.000	-
$I_s = \text{Hex „3“}$	0.396	0.418	0.440	0.462	0.484	0.506	0.528	0.572	0.616	0.660	0.704	0.792	0.880	0.990	1.100	-
$I_s = \text{Hex „4“}$	0.432	0.456	0.480	0.504	0.528	0.552	0.576	0.624	0.672	0.720	0.768	0.864	0.960	1.080	1.200	-
$I_s = \text{Hex „5“}$	0.468	0.494	0.520	0.546	0.572	0.598	0.624	0.676	0.728	0.780	0.832	0.936	1.040	1.170	1.300	-
$I_s = \text{Hex „6“}$	0.504	0.532	0.560	0.588	0.616	0.644	0.672	0.728	0.784	0.840	0.896	1.008	1.120	1.260	1.400	-
$I_s = \text{Hex „7“}$	0.540	0.570	0.600	0.630	0.660	0.690	0.720	0.780	0.840	0.900	0.960	1.080	1.200	1.350	1.500	-

Table 6.2: Test current via CD winding with the $I>$ step and the different I_s setting values

6.7.3 Switching points for the short-circuit steps I>> (only WIB12FE and WIB12PE)

DIP 2-5	OFF	ON	OFF	ON	OFF	ON	OFF	ON	OFF	ON	OFF	ON	OFF	ON	OFF	ON
DIP 2-6	OFF	OFF	ON	ON	OFF	OFF	ON	ON	OFF	OFF	ON	ON	OFF	OFF	ON	ON
DIP 2-7	OFF	OFF	OFF	OFF	ON	ON	ON	ON	OFF	OFF	OFF	OFF	ON	ON	ON	ON
DIP 2-8	OFF	OFF	OFF	OFF	OFF	OFF	OFF	OFF	ON	ON	ON	ON	ON	ON	ON	ON
Setting value	1	1.5	2	3	4	5	6	7	8	9	10	12	14	16	18	20
I>> x Is																
Is = Hex „0“	0.32	0.48	0.64	0.96	1.28	1.60	1.92	2.24	2.56	2.88	3.20	3.84	4.48	5.12	5.76	6.40
Is = Hex „1“	0.36	0.54	0.72	1.08	1.44	1.80	2.16	2.52	2.88	3.24	3.60	4.32	5.04	5.76	6.48	7.20
Is = Hex „2“	0.40	0.60	0.80	1.20	1.60	2.00	2.40	2.80	3.20	3.60	4.00	4.80	5.60	6.40	7.20	8.00
Is = Hex „3“	0.44	0.66	0.88	1.32	1.76	2.20	2.64	3.08	3.52	3.96	4.40	5.28	6.16	7.04	7.92	8.80
Is = Hex „4“	0.48	0.72	0.96	1.44	1.92	2.40	2.88	3.36	3.84	4.32	4.80	5.76	6.72	7.68	8.64	9.60
Is = Hex „5“	0.52	0.78	1.04	1.56	2.08	2.60	3.12	3.64	4.16	4.68	5.20	6.24	7.28	8.32	9.36	10.40
Is = Hex „6“	0.56	0.84	1.12	1.68	2.24	2.80	3.36	3.92	4.48	5.04	5.60	6.72	7.84	8.96	10.08	11.20
Is = Hex „7“	0.60	0.90	1.20	1.80	2.40	3.00	3.60	4.20	4.80	5.40	6.00	7.20	8.40	9.60	10.80	12.00
Is = Hex „8“	0.64	0.96	1.28	1.92	2.56	3.20	3.84	4.48	5.12	5.76	6.40	7.68	8.96	10.24	11.52	12.80
Is = Hex „9“	0.68	1.02	1.36	2.04	2.72	3.40	4.08	4.76	5.44	6.12	6.80	8.16	9.52	10.88	12.24	13.60
Is = Hex „A“	0.72	1.08	1.44	2.16	2.88	3.60	4.32	5.04	5.76	6.48	7.20	8.64	10.08	11.52	12.96	14.40
Is = Hex „B“	0.80	1.20	1.60	2.40	3.20	4.00	4.80	5.60	6.40	7.20	8.00	9.60	11.20	12.80	14.40	16.00
Is = Hex „C“	0.88	1.32	1.76	2.64	3.52	4.40	5.28	6.16	7.04	7.92	8.80	10.56	12.32	14.08	15.84	17.60
Is = Hex „D“	0.96	1.44	1.92	2.88	3.84	4.80	5.76	6.72	7.68	8.64	9.60	11.52	13.44	15.36	17.28	19.20
Is = Hex „E“	1.04	1.56	2.08	3.12	4.16	5.20	6.24	7.28	8.32	9.36	10.40	12.48	14.56	16.64	18.72	20.80
Is = Hex „F“	1.12	1.68	2.24	3.36	4.48	5.60	6.72	7.84	8.96	10.08	11.20	13.44	15.68	17.92	20.16	22.40

Table 6.3: Test current via CD winding with the I>> step and the different Is setting values

6.7.4 Switching points for the blocking function steps I_{BLOCK} (only WIB12PEB)

DIP 2-5	OFF	ON	OFF	ON	OFF	ON	OFF	ON	OFF	ON	OFF	ON	OFF	ON	OFF	ON
DIP 2-6	OFF	OFF	ON	ON	OFF	OFF	ON	ON	OFF	OFF	ON	ON	OFF	OFF	ON	ON
DIP 2-7	OFF	OFF	OFF	OFF	ON	ON	ON	ON	OFF	OFF	OFF	OFF	ON	ON	ON	ON
DIP 2-8	OFF	OFF	OFF	OFF	OFF	OFF	OFF	OFF	ON	ON	ON	ON	ON	ON	ON	ON
Setting value	1	2	3	4	5	6	7	8	9	10	12	14	16	18	20	EXIT
I _{BLOCK} x Is																
Is = Hex „0“	0.32	0.64	0.96	1.28	1.60	1.92	2.24	2.56	2.88	3.20	3.84	4.48	5.12	5.76	6.40	-
Is = Hex „1“	0.36	0.72	1.08	1.44	1.80	2.16	2.52	2.88	3.24	3.60	4.32	5.04	5.76	6.48	7.20	-
Is = Hex „2“	0.40	0.80	1.20	1.60	2.00	2.40	2.80	3.20	3.60	4.00	4.80	5.60	6.40	7.20	8.00	-
Is = Hex „3“	0.44	0.88	1.32	1.76	2.20	2.64	3.08	3.52	3.96	4.40	5.28	6.16	7.04	7.92	8.80	-
Is = Hex „4“	0.48	0.96	1.44	1.92	2.40	2.88	3.36	3.84	4.32	4.80	5.76	6.72	7.68	8.64	9.60	-
Is = Hex „5“	0.52	1.04	1.56	2.08	2.60	3.12	3.64	4.16	4.68	5.20	6.24	7.28	8.32	9.36	10.40	-
Is = Hex „6“	0.56	1.12	1.68	2.24	2.80	3.36	3.92	4.48	5.04	5.60	6.72	7.84	8.96	10.08	11.20	-
Is = Hex „7“	0.60	1.20	1.80	2.40	3.00	3.60	4.20	4.80	5.40	6.00	7.20	8.40	9.60	10.80	12.00	-
Is = Hex „8“	0.64	1.28	1.92	2.56	3.20	3.84	4.48	5.12	5.76	6.40	7.68	8.96	10.24	11.52	12.80	-
Is = Hex „9“	0.68	1.36	2.04	2.72	3.40	4.08	4.76	5.44	6.12	6.80	8.16	9.52	10.88	12.24	13.60	-
Is = Hex „A“	0.72	1.44	2.16	2.88	3.60	4.32	5.04	5.76	6.48	7.20	8.64	10.08	11.52	12.96	14.40	-
Is = Hex „B“	0.80	1.60	2.40	3.20	4.00	4.80	5.60	6.40	7.20	8.00	9.60	11.20	12.80	14.40	16.00	-
Is = Hex „C“	0.88	1.76	2.64	3.52	4.40	5.28	6.16	7.04	7.92	8.80	10.56	12.32	14.08	15.84	17.60	-
Is = Hex „D“	0.96	1.92	2.88	3.84	4.80	5.76	6.72	7.68	8.64	9.60	11.52	13.44	15.36	17.28	19.20	-
Is = Hex „E“	1.04	2.08	3.12	4.16	5.20	6.24	7.28	8.32	9.36	10.40	12.48	14.56	16.64	18.72	20.80	-
Is = Hex „F“	1.12	2.24	3.36	4.48	5.60	6.72	7.84	8.96	10.08	11.20	13.44	15.68	17.92	20.16	22.40	-

Table 6.4: Test current via CD winding with the I_{BLOCK} step and the different Is setting values

6.8 Special features for earth current tests

Functional description:

In the WIB1 the earth current is calculated and cannot be measured. It is established from the geometrical amount of the three phase current values, more or less a numerical Holmgreen. If, for instant, a single-phase test current is impressed, the measuring value (tripping value) in the earth current path equals the current in the tested phase. If, with a phase shift of 120° a three-phase test current is impressed, the measuring value in the earth current path equals zero.

Requirement on the test system:

The WIB1 is powered by the instrument transformer. In order to guarantee reliable tripping a minimal current of 0.9 x lowest nominal CT current (0.9 x lowest I_> setting) has to flow in one of the phases. If the setting of the earth current I_{E>} is lower than the smallest possible switching point for the phase current, then the switching point for earth current tripping can only be tested by a three-phase power source. In case the set switching point for earth current is higher than the smallest possible switching point for overcurrent tripping (I_s x I_>), then the test can be performed with a single-phase power source.

6.8.1 Switching points for the earth current step I_{E>}

DIP 3-7	OFF	ON	OFF	ON	OFF	ON	OFF	ON	OFF	ON	OFF	ON	OFF	ON	OFF	ON
DIP 3-8	OFF	OFF	ON	ON	OFF	OFF	ON	ON	OFF	OFF	ON	ON	OFF	OFF	ON	ON
DIP 4-1	OFF	OFF	OFF	OFF	ON	ON	ON	ON	OFF	OFF	OFF	OFF	ON	ON	ON	ON
DIP 4-2	OFF	OFF	OFF	OFF	OFF	OFF	OFF	OFF	ON	ON	ON	ON	ON	ON	ON	ON
Einstellwert I _{E>} x I _s	0.2*	0.3*	0.4*	0.5*	0.6*	0.7*	0.8*	0.9	1	1.2	1.4	1.6	1.8	2.0	2.5	EXIT
I _s = Hex „0“	0,064	0,096	0,128	0,160	0,192	0,224	0,256	0,288	0,320	0,384	0,448	0,512	0,576	0,640	0,800	-
I _s = Hex „1“	0,072	0,108	0,144	0,180	0,216	0,252	0,288	0,324	0,360	0,432	0,504	0,576	0,648	0,720	0,900	-
I _s = Hex „2“	0,080	0,120	0,160	0,200	0,240	0,280	0,320	0,360	0,400	0,480	0,560	0,640	0,720	0,800	1,000	-
I _s = Hex „3“	0,088	0,132	0,176	0,220	0,264	0,308	0,352	0,396	0,440	0,528	0,616	0,704	0,792	0,880	1,100	-
I _s = Hex „4“	0,096	0,144	0,192	0,240	0,288	0,336	0,384	0,432	0,480	0,576	0,672	0,768	0,864	0,960	1,200	-
I _s = Hex „5“	0,104	0,156	0,208	0,260	0,312	0,364	0,416	0,468	0,520	0,624	0,728	0,832	0,936	1,040	1,300	-
I _s = Hex „6“	0,112	0,168	0,224	0,280	0,336	0,392	0,448	0,504	0,560	0,672	0,784	0,896	1,008	1,120	1,400	-
I _s = Hex „7“	0,120	0,180	0,240	0,300	0,360	0,420	0,480	0,540	0,600	0,720	0,840	0,960	1,080	1,200	1,500	-

Table 6.4: Test current via the CD winding with the I_{E>} step and the different I_s setting values

* When the earth current setting is <0.9 x I_s a three-phase test system has to be used for correct testing. With a single-phase test the trip is only triggered from 0.9 x I_s on.

6.8.2 Switching points for the earth current short-circuit step I_{E>>}

DIP 2-5	OFF	ON	OFF	ON	OFF	ON	OFF	ON
DIP 2-6	OFF	OFF	ON	ON	OFF	OFF	ON	ON
DIP 2-7	OFF	OFF	OFF	OFF	ON	ON	ON	ON
DIP 2-8	OFF	OFF	OFF	OFF	OFF	OFF	OFF	ON
Setting value I _{E>>} x I _s	1	2	3	4	5	6	7	EXIT
I _s = Hex „0“	0.32	0.64	0.96	1.28	1.60	1.92	2.24	-
I _s = Hex „1“	0.36	0.72	1.08	1.44	1.80	2.16	2.52	-
I _s = Hex „2“	0.40	0.80	1.20	1.60	2.00	2.40	2.80	-
I _s = Hex „3“	0.44	0.88	1.32	1.76	2.20	2.64	3.08	-
I _s = Hex „4“	0.48	0.96	1.44	1.92	2.40	2.88	3.36	-
I _s = Hex „5“	0.52	1.04	1.56	2.08	2.60	3.12	3.64	-
I _s = Hex „6“	0.56	1.12	1.68	2.24	2.80	3.36	3.92	-
I _s = Hex „7“	0.60	1.20	1.80	2.40	3.00	3.60	4.20	-

Table 6.5: Test current via CD winding with the I_{E>>} step and the different I_s setting values

6.9 Test procedure by way of example

When testing the WIB1, the tests of the individual equipment should be carried out from the highest setting value to the smallest one. The order ought to be:

- 1) Short circuit $I_{>>}$
- 2) Time delay $t_{i>>}$
- 3) Over current $I_{>}$
- 4) Time delay $t_{i>}$
- 5) Earth current $I_{E>>}$ high set
- 6) Earth current $I_{E>}$ low set
- 7 Time delay $t_{iE>}$

In here the complete test can only be exemplified with free defined switching points. For the test a single-phase power source has to be used.

General setting:

I_s = Nominal Current of the equipment conditional on the used CT, on which all switching points of $I_{>>}$, $I_{>}$, $I_{E>>}$ and $I_{E>}$ are based.

CHAR = either Definite Time or Inverse Characteristic – dependent on the requirement.

The device will be adjusted by way of the DIP switches.

Here the test will be performed with the following settings:

```

 $I_s = 1.15$ 
 $I\_Char = \text{Definite Time}$ 
 $I_{>} = 1.05 \times I_s$ 
 $t_{i>} = 1.00 \text{ s}$ 
 $I_{>>} = 4.00 \times I_s$ 
 $t_{i>>} = 0.20 \text{ s}$ 
 $I_{E\_Char} = \text{Definite Time}$ 
 $I_{E>} = 0.9 \times I_s$ 
 $t_{iE>} = 0.2 \text{ s}$ 
 $I_{E>>} = 2.00 \times I_s$ 

```

Test step 1): Test of the short circuit step $I_{>>}$. For this the following parameters have to be blocked:

```

 $I_{>} = \text{EXIT}$ 
 $t_{i>>} = \text{EXIT}$ 
 $I_{E>} = \text{EXIT}$ 
 $I_{E>>} = \text{EXIT}$ 

```

The single-phase test current has to be increased slowly until the relay or the LED indicator trips. The tripping current can be controlled by the fault value memory. Since the WIB1 is operating phase-selectively, each phase can be tested separately.

Test step 2): Test of the trip delay $t_{i>>}$

Settings: $I_{>>} = 4.00 \times I_s$
 $t_{i>>} = \text{e.g. } 0.10 \text{ s}$

During the single-phase test the switching point of $I_{>>}$ setting has to be rapidly changed from 80% to 120%. The tripping time is ascertained by an external timer. The jump is to be used as start impulse. The trip impulse coming from the flag indicator or the tripping coil serves as stop signal. If a 80% or 120% jump is not possible with the test instrument, then the jump should be from 0 to 120% of the $I_{>>}$. Dependent on the test parameter for $I_{>>}$ and the set tripping time for $t_{i>>}$, the charging and boot time needed by the relay has to be deducted. See chapter 4.1.2 Phase Over-Current Time Protection.

Test step 3): Test of the over-current step I_>:

Settings: I_> = 1.05 x I_s
 t_{I>} = EXIT
 I_{>>} = 4.00 x I_s
 t_{I>>} = 0.10 s
 I_{E>} = EXIT
 t_{I_{E>}} = 0.2 s
 I_{E>>} = EXIT

Test to be carried out as described under “Test step 1”.

Test step 4): Test of the trip delay t_{I>}

Settings: I_> = 1.05 x I_s
 t_{I>} = 1.00 s

Test to be carried out as described under „Test step 2“.

Test step 5): Test of the earth current step I_{E>}

Settings: I_> = EXIT
 t_{I>} = 1.00 s
 I_{>>} = 4.00 x I_s
 t_{I>>} = 0.10 s
 I_{E>} = EXIT
 I_{E>>} = 2 x I_s

Test to be carried out as described under „Test step 2“. This protection function has only an instantaneous tripping delay time.

Test step 6): Test of the earth current step I_{E>}

Settings: I_> = EXIT
 t_{I>} = 1.00 s
 I_{>>} = 4.00 x I_s
 t_{I>>} = 0.10 s
 I_{E>} = 0.9 x I_s
 t_{I_{E>}} = EXIT
 I_{E>>} = 2 x I_s

Test to be carried out as described under „Test step 1“.

Test step 7): Test of the trip delay t_{I_{E>}}

Settings: I_{E>} = 0.9 x I_s
 t_{I_{E>}} = 0.2 s

Test to be carried out as described under „Test step 2“.

NOTICE

Tests on the earth current path can only be performed with a single-phase power source if the switching point for the I_{E>} setting is ≥ 0.9 x I_s. See chapter 5.8.

6.10 Maintenance

The entire protection system WIB1 is designed for a maintenance-free period of 25 years, hence there are no specific jobs necessary to be done during the operating life of the relays. Very often, a periodical check of the protective adjustments is required by the end user. Such checks are left to the choice of the user and can be carried out as described under chapter 6.2.

6.10.1 Faults

Should, however, faults occur despite the special design of the protection system and the comprehensive quality control, the possibility for fault clearance by the user is only limited. For possible faults and their clearance please see the following table:

Fault	Cause of failure	Remedy
Wrong measuring and tripping values	Test winding short-circuited	Secondary side of test winding always to be operated openly (except when relays are tested)
Wrong measuring and tripping values	Earthing of a winding terminal of the measuring winding	No winding terminal of the measuring winding to be earthed! Earthing is done internally and brought out at terminal PE
Low-energy tripping coil does not trip	Coil polarized with permanent magnet wrong connected to TC+ and TC-	Wiring to be checked

6.10.2 Repair work

The WIB1 is a hermetically sealed relay and so it is not possible to do any repair work at your end. Due to the optimized cost structure, however, repair in our works is also not beneficial. During the warranty period the protection relay is exchanged by us free of charge, provided the failure was not caused by external influences. Should such a situation occur, please contact our local sales agent.

7. Product Specific Features

7.1 Assignment of terminals

7.1.1 Assignment of terminals at WIB12PE and WIB12PEB

The protection relay is equipped with 22 screw-type terminals

Terminal marking	Description
230 V	Remote trip input for auxiliary voltage 230 V AC
115 V	Remote trip input for auxiliary voltage 115 V AC
N	Remote trip input N (earth)
PE	Centre earthing point WIC1
FI+	Flag indicator output for phase failure, +pole
FI-	Flag indicator output for phase failure, -pole
TC+	Electric pulse output +pole
TC-	Electric pulse output, -pole
FE+	Flag indicator output for earth failure, +pole
FE-	Flag indicator output for earth failure, -pole
L1_S1	CT measuring winding connection L1
L2_S2	CT measuring winding connection L1
L2_S1	CT measuring winding connection L2
L2_S2	CT measuring winding connection L2
L3_S1	CT measuring winding connection L3
L3_S2	CT measuring winding connection L3

The terminals 230 V, 115 V, N and PE are provided as fixed terminals.

7.1.2 Assignment of terminals at WIB12FE

The protection relay is equipped with 16 screw-type terminals

Terminal marking	Description
230 V	Remote trip input for auxiliary voltage 230 V AC
115 V	Remote trip input for auxiliary voltage 115 V AC
N	Remote trip input N (earth)
PE	Centre earthing point WIC1
FI+	Flag indicator output for phase failure, +pole
FI-	Flag indicator output for phase failure, -pole
TC+	Electric pulse output +pole
TC-	Electric pulse output, -pole
FE+	Flag indicator output for earth failure, +pole
FE-	Flag indicator output for earth failure, -pole

The terminals 230 V, 115 V, N and PE are provided as fixed terminals.

7.1.3 Earthing

For earthing the WIB1 connection terminal PE is used.



The measuring winding (terminals S1 and S2) of the CTs must not be earthed; otherwise the measurement results are distorted, ensuring in erratic behavior of the relay.

	3.00	3.30	4.20	5.50	6.00	6.60	10.00	11.00	12.00	13.80	15.00	15.50	17.50	20.00	21.00	22.00	24.00	U[kV]
1000.00	WIC1-W6																	
1250.00	240,56																	
1600.00	307,92	279,93																
2000.00	384,90	349,91	274,93															
2500.00	481,13	437,39	343,66	262,43	240,56													
3000.00	606,22	551,11	433,01	330,66	303,11	275,55												
4000.00	769,80	699,82	549,86	419,89	384,90	349,91	230,94											
5000.00	962,25	874,77	687,32	524,86	481,13	437,39	288,68	262,43	240,56									
6300.00	1212,44	1102,21	866,03	661,33	606,22	551,11	363,73	330,66	303,11	263,57	242,49	234,66						
10000.00		1749,55	1374,64	1049,73	962,25	874,77	577,35	524,86	481,13	418,37	384,90	372,48						
S[kVA]																		

8. Annex

8.1 Dimensional drawing relay

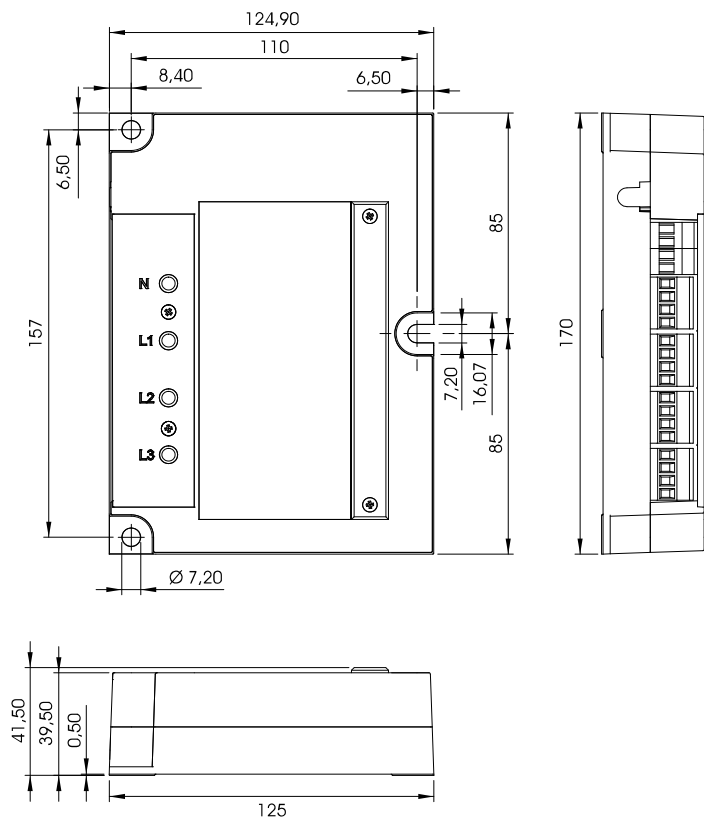

Figure 8.1: Dimensional drawing

8.2 Dimensional drawing flag indicator

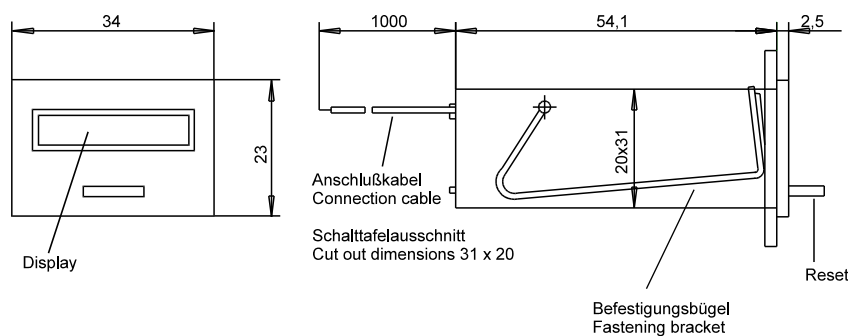

Figure 8.2: Flag indicator W11-SZ4/W11-SZ5

8.3 Order form

Multi characteristic time over current relay	WIB1	2		E	
3-phase current measuring I>;I>>					
self powered – parameter setting via DIP switches		2			
Connection mode - plug in screw terminals connectors for test winding Routine Safety Check with backup protection I>> (only WIB12PE)			P		
– fixed screw terminal			F		
With additional earth current supervision* I _E > – standard 0.2 to 2.5 x I _S (internal vector addition)					
With blocking funktion (I _{BLOCK}) (only WIB12PEB)					B

The following device variants can be ordered:

WIB12PE
WIB12PEB
WIB12FE

Flag indicators	WI1	
Small type, front 34 x 23 mm, connection lead 1m		SZ4
Small type, front 34 x 23 mm, connection lead 1m with bi-stable signal contact 230 V AC, 3 A		SZ5

Accessories	WIC1	
PC adapter for RS232 serial port		PC2
PC adapter for USB port		PC3
Watchdog test unit		TU

Current transformer (1 piece)			Order Code	
(Short name + Primary Current Range + Accuracy Class)			Construction type 1	Construction type 2
WE2	16 – 56 A	5P80	WIC1-CT2-5P	WIC1WE2AS1
W2	16 – 56 A	10P80	WIC1-CT2-10P	WIC1W2AS1
W3	32 – 112 A	5P80	WIC1-CT3	WIC1W3AS1
W4	64 – 224 A	5P80	WIC1-CT4	WIC1W4AS1
W5	128 – 448 A	5P80	WIC1-CT5	WIC1W5AS1
W6	256 – 896 A	5P80	-	WIC1W6AS1

Further designs e.g. supporting type, plug-on type etc. on request.

Note: CT housing in accordance with the customer requirements.

8.4 Commissioning form

List of adjustments for WIB1

Project: _____ Order No.: _____

Functional group: _____ Location: _____ Component Identification: _____

Relay Function: _____ Date: _____

8.4.1 Parameter Setting WIB12FE and WIB12PE

Function		Unit	Default Setting	Actual Setting
	CT Type		Wx	
Is	Rated CT current e.g. W2 type of CT	A	16	
I_Char	Trip characteristic for phase current		DEFT	
I _E _Char	Trip characteristic for earth current		DEFT	
I>	Pickup value for DMT characteristic or start value of the IMT characteristic	x Is	0.9	
tI>	Tripping time for DMT characteristic	s	0.1	
a	Multiplier for IMT characteristic	s	--	
I>>	Pickup value for short-circuit element	x Is	1	
tI>>	Tripping time for short-circuit element	s	0.04	
I _E >	Pickup value for earth fault element	x Is	0.2	
tI _E >	Tripping time for earth fault element	s	0.1	
I _E >>	Pickup value for the 2 nd earth fault element	x Is	1	

8.4.2 Parameter Setting WIB12PEB

Function		Unit	Default Setting	Actual Setting
	CT Type		Wx	
Is	Rated CT current e.g. W2 type of CT	A	16	
I_Char	Trip characteristic for phase current		DEFT	
I _E _Char	Trip characteristic for earth current		DEFT	
I>	Pickup value for DMT characteristic or start value of the IMT characteristic	x Is	0.9	
tI>	Tripping time for DMT characteristic	s	0.1	
a	Multiplier for IMT characteristic	s	--	
I _{BLOCK}	Pickup value for blocking function	x Is	1	
I _E >	Pickup value for earth fault element	x Is	0.2	
tI _E >	Tripping time for earth fault element	s	0.1	
I _E >>	Pickup value for the 2 nd earth fault element	x Is	1	

Signature Checker: _____ Signature customer: _____

WI Line

www.SEGelectronics.de

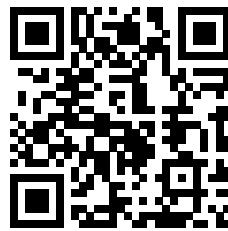

SEG Electronics GmbH reserves the right to update any portion of this publication at any time. Information provided by SEG Electronics GmbH is believed to be correct and reliable. However, SEG Electronics GmbH assumes no responsibility unless otherwise expressly undertaken.



SEG Electronics GmbH
Krefelder Weg 47 • D-47906 Kempen (Germany)
Postfach 10 07 55 (P.O.Box) • D-47884 Kempen (Germany)
Telephone: +49 (0) 21 52 145 1

Internet: www.SEGelectronics.de

Sales
Telephone: +49 (0) 21 52 145 331
Fax: +49 (0) 21 52 145 354
E-mail: info@SEGelectronics.de

Service
Telephone: +49 (0) 21 52 145 600
Fax: +49 (0) 21 52 145 354
E-mail: info@SEGelectronics.de

SEG Electronics has company-owned plants, subsidiaries, and branches, as well as authorized distributors and other authorized service and sales facilities throughout the world.

Complete address / phone / fax / email information for all locations is available on our website.