

XRW1 - Mains decoupling relay for wind power systems

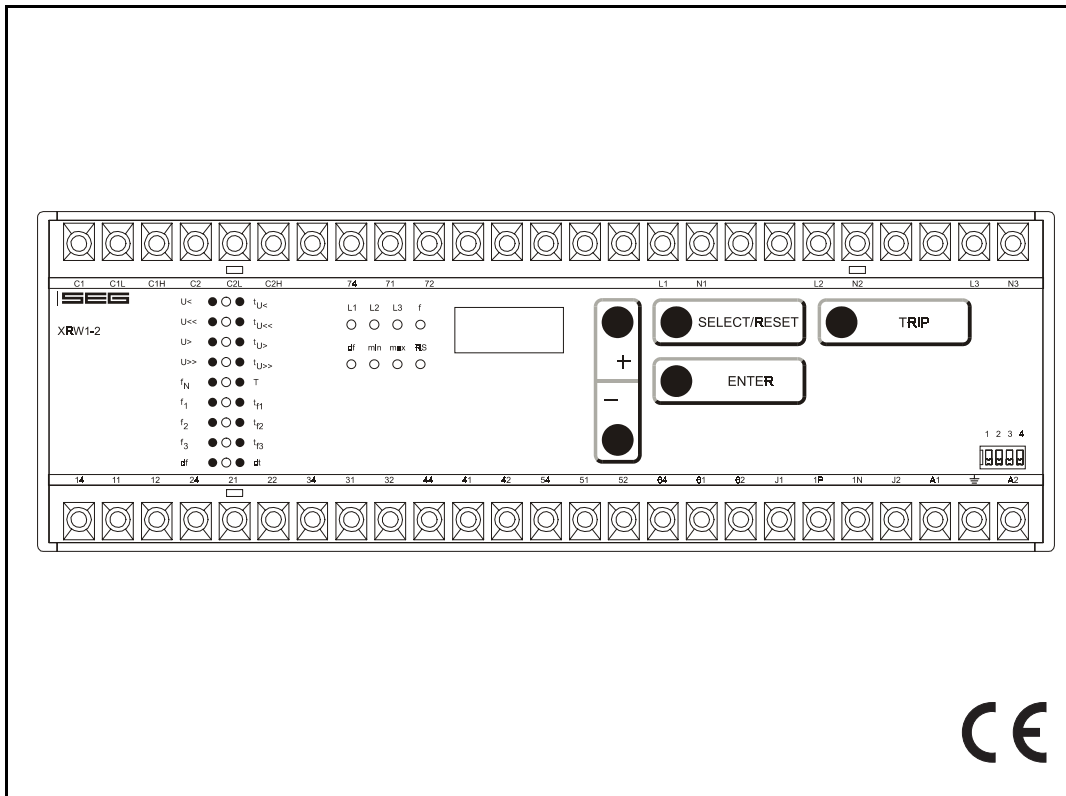

Contents

1 Introduction and application

2 Features and characteristics

3 Design

- 3.1 Connections
 - 3.1.1 Analog input circuits
 - 3.1.2 Blocking input
 - 3.1.3 Reset input
 - 3.1.4 Output relays
 - 3.1.5 Data communication
- 3.2 Front plate
 - 3.2.1 Indication- and operation elements
 - 3.2.2 Display
 - 3.2.3 LEDs
 - 3.2.4 Front plate XRW1
 - 3.2.5 Parameter settings

4 Working principle

- 4.1 Analog circuits
- 4.2 Digital circuits
- 4.3 Voltage supervision
 - 4.3.1 Selection of star or delta connection
- 4.4 Principle of frequency supervision
- 4.5 Measuring of frequency gradient (XRW1-2)
- 4.6 Voltage threshold value for frequency measuring
- 4.7 Blocking function

5 Operation and setting

- 5.1 Push buttons
 - 5.1.1 Indication of measuring values and fault data
- 5.2 DIP switches
 - 5.2.1 Function of the output relays
- 5.3 Reset
- 5.4 Password
 - 5.4.1 Password programming
 - 5.4.2 Using the password
- 5.5 Relay setting principle
 - 5.5.1 Setting of default parameters
 - 5.5.2 Blocking the protection functions
- 5.6 Display of software version and test-TRIP
- 5.7 Low/High range of functions blocking and reset

6 Special settings

- 6.1 Adjustable parameters
- 6.2 Setting procedure
 - 6.2.1 Parameter setting of over- and undervoltage supervision
 - 6.2.2 Setting of nominal frequency
 - 6.2.3 Number of measuring repetitions (T) for frequency functions
 - 6.2.4 Threshold of frequency supervision
 - 6.2.5 Tripping delays for the frequency elements

- 6.2.6 Parameter setting of frequency gradient
- 6.2.7 Voltage threshold value for frequency and df/dt measuring
- 6.2.8 Adjustment of the slave address
- 6.2.9 Setting procedure for blocking the protection functions
- 6.3 Indication of measuring values
 - 6.3.1 Min./Max.- values
- 6.4 Reset

7 Relay testing and commissioning

- 7.1 Power-On
- 7.2 Testing the output relays
- 7.3 Checking the set values
- 7.4 Secondary injection test
 - 7.4.1 Test equipment
 - 7.4.2 Example of test circuit
 - 7.4.3 Checking the input circuits and measuring functions
 - 7.4.4 Checking the operating and resetting values of the over/undervoltage functions
 - 7.4.5 Checking the relay operating time of the over/undervoltage functions
 - 7.4.6 Checking the operating and resetting values of the over/underfrequency functions
 - 7.4.7 Checking the relay operating time of the over/underfrequency functions
 - 7.4.8 Checking the external blocking and reset functions
- 7.5 Primary injection test
- 7.6 Maintenance

8 Technical data

- 8.1 Measuring input circuits
- 8.2 Common data
- 8.3 Setting ranges and steps
- 8.4 Output relays
- 8.5 Power supply
- 8.6 Inputs, blockage and reset
- 8.7 System data and test specifications
- 8.8 Relay case

9 Order form

1 Introduction and application

The *XRW1* is a universal mains decoupling device and covers the protection requirements from VDEW and most other utilities for the mains parallel operation of power stations.

- Over/ and undervoltage protection
- Over/ and underfrequency protection
- Rate of change of frequency df/dt

Because of combination of three protectional functions in one device the *XRW1* is a very compact mains decoupling device. Compared to the standardly used single devices it has a very good price/performance ratio.

2 Features and characteristics

- Microprocessor technology with watchdog
- Effective analogue low pass filter for suppressing harmonics when measuring frequency
- Digital filtering of the measured values by using discrete Fourier analysis to suppress higher harmonics and d.c. components induced by faults or system operations
- Integrated functions for voltage and frequency supervision in one device.
- Voltage supervision each with two step under-/ and overvoltage detection
- Frequency supervision with three step under-/ or overfrequency (user setting)
- Completely independent time settings for voltage and frequency supervision
- Adjustable voltage threshold value for blocking frequency measuring.
- Display of all measuring values and setting parameters for normal operation as well as tripping via a alphanumeric display and LEDs
- Storage and indication of the tripping values
- In compliance with VDE 0435, part 303 and IEC 255
- For blocking the individual functions by the external blocking input, parameters can be set according to requirement
- Windtest certified

This manual is valid for relay software version from DO4_7.23 (for XRW1-2) onwards.

3 Design

3.1 Connections

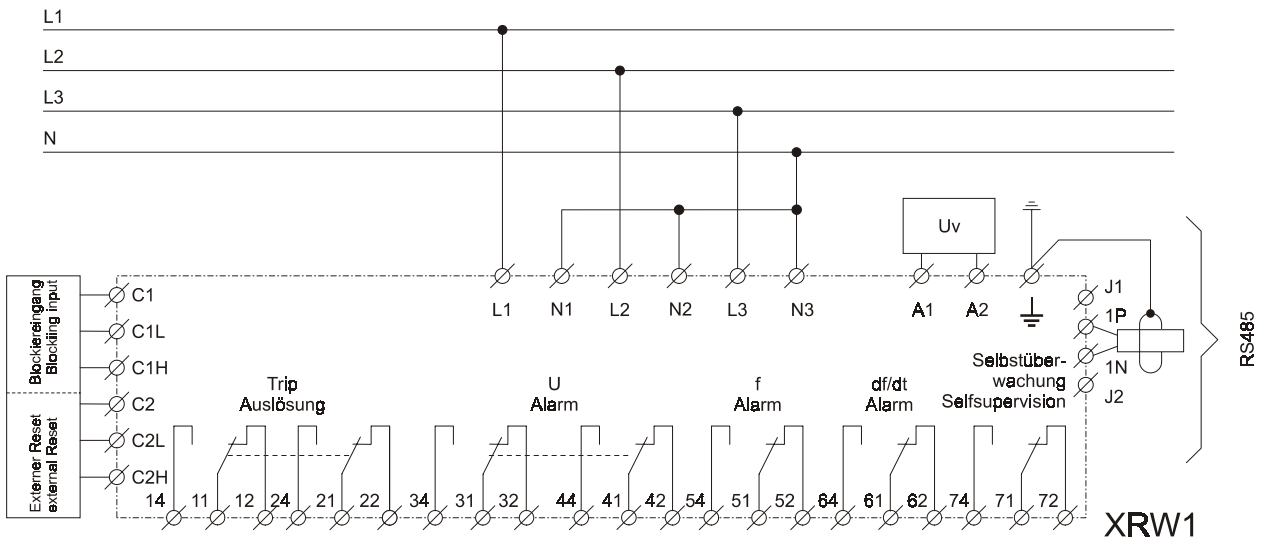

Fig.3.1: Connection diagram XRW1-2

3.1.1 Analog input circuits

The analog input voltages are galvanically decoupled by the input transformers of the device, then filtered and finally fed to the analog digital converter. The measuring circuits can be applied in star or delta connection (refer to chapter 4.3.1).

3.1.2 Blocking input

The blocking function can be set according to requirement. By applying the auxiliary voltage to C1/C1L or C1/C1H, the previously set relay functions are blocked (refer to 4.7).

3.1.3 Reset input

Please refer to chapter 6.4.

3.1.4 Output relays

The XRW1 has 5 output relays. One trip relay with two changeover contacts. One alarm relay with two changeover contacts and three alarm relays with one changeover contact.

- Tripping 11, 12, 14 and 21, 22, 24
- Indication of over-/ and undervoltage alarm 31, 32, 34 and 41, 42, 44
- Indication of over-/ and underfrequency alarm 51, 52, 54
- Indication 61, 62, 64, df/dt-alarm
- Indication self supervision (internal fault of the unit) 71, 72, 74

All trip and alarm relays are normally-off relays, the relay for self supervision is a normally-on relay.

3.1.5 Data communication

For data communication with a central control system the *XRW1* relay is provided with a serial interface RS485. Simplified and fast reading and changing of parameters and measuring values can be achieved by *HTL/PL-Soft4*, which will be provided on request together with the relay.

The *XRW1* can be connected to other units of the *PROFESSIONAL LINE* via interface. If there are more than one relay in the system, the last relay of the chain has to be provided with a line termination resistor.

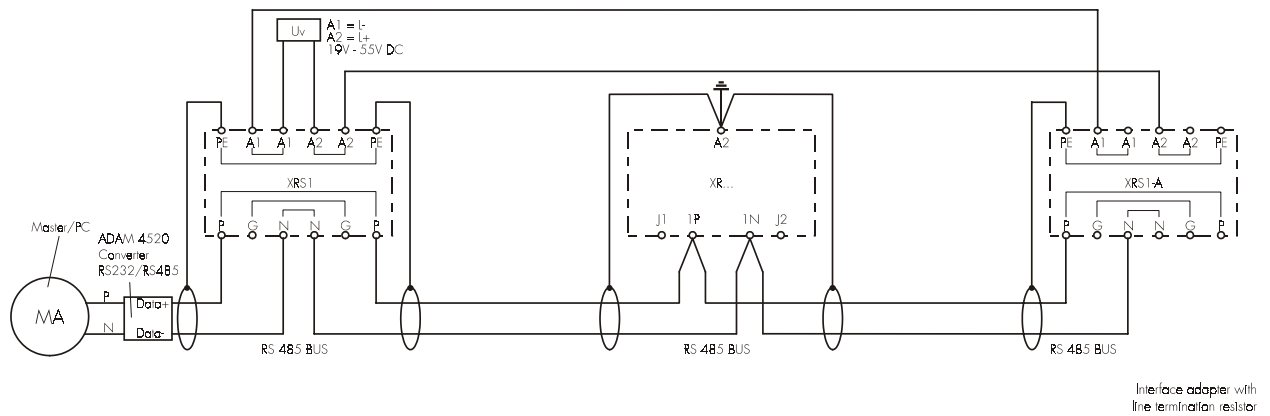

Fig. 3.2: Connection example with 3 users, XR ... as linked device

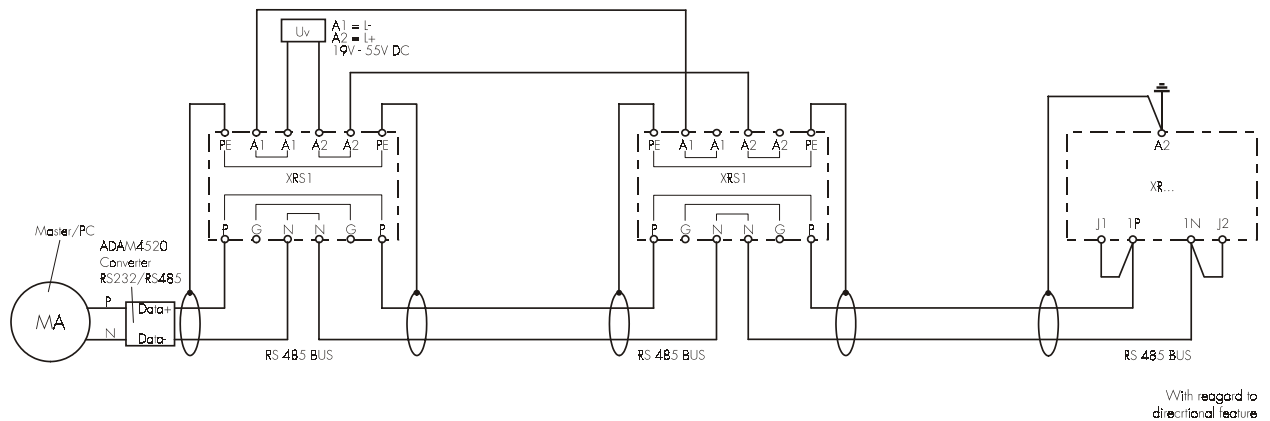

Fig. 3.3: Connection example with 3 users, XR ... as last device

3.2 Front plate

3.2.1 Indication- and operation elements

The front plate of the *XRW1*-protection relay comprises the following operation and indication elements:

- Alphanumerical display (4 Digits)
- Push buttons for setting and other operations
- LEDs for measured value indication and setting

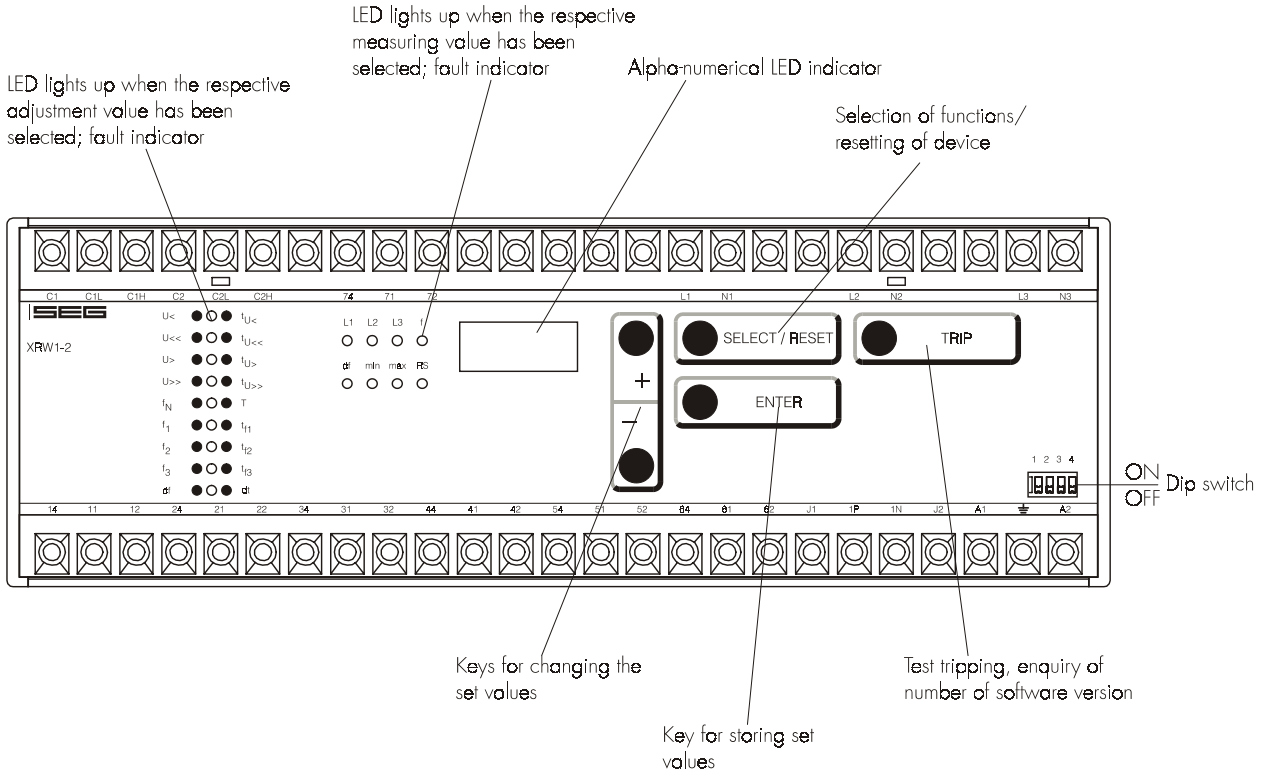

Fig. 3.4: Front plate XRW1

3.2.2 Display

Function	Display shows	Pressed pushbutton	Corresponding LED
Normal operation	SEG		
Measured operating values	Actual measured value Min. and max. values of voltage and frequency	<SELECT/RESET> one time for each value	L1, L2, L3, f, min, max df
Setting values: star/delta connection	Y/DELT	<SELECT/RESET><+><>	Δ/Y
undervoltage (low set) tripping delay of low set element	setting value in volt setting value in seconds	<SELECT/RESET><+><> one time for each value	U< $t_{U<}$
undervoltage (high set) tripping delay of high set element	setting value in volt setting value in seconds	<SELECT/RESET><+><> one time for each value	U<< $t_{U<<}$
overvoltage (low set) tripping delay of low set element	setting value in volt setting value in seconds	<SELECT/RESET><+><> one time for each value	U> $t_{U>}$
overvoltage (high set) tripping delay of high set element	setting value in volt setting value in seconds	<SELECT/RESET><+><> one time for each value	U>> $t_{U>>}$
rated frequency	setting value in Hz	<SELECT/RESET><+><>	f_N
frequency measuring repetition	setting value	<SELECT/RESET><+><>	T
frequency element f_1 tripping delay of frequency element f_1	setting value in Hz setting value in seconds	<SELECT/RESET><+><> one time for each value	f_1 t_{f_1}
frequency element f_2 tripping delay of frequency element f_2	setting value in Hz setting value in seconds	<SELECT/RESET><+><> one time for each value	f_2 t_{f_2}
frequency element f_3 tripping delay of frequency element f_3	setting value in Hz setting value in seconds	<SELECT/RESET><+><> one time for each value	f_3 t_{f_3}
setting value df/dt measuring repetition df/dt	setting value in Hz/s setting value in periods	<SELECT/RESET><+><> one time for each value	df dt
Blocking	EXIT	<+> until max. setting value	LED of blocked parameter
Undervoltage blocking of frequency and df/dt measuring	setting value in Volt	<SELECT/RESET><+><>	f, df
Slave address of serial interface	1 - 32	<SELECT/RESET><+><>	RS
Recorded fault data: star-connection: U1, U2, U3 delta-connection: U12, U23, U31	tripping values in Volt	<SELECT/RESET><+><> one time for each phase	L1, L2, L3, U<, U<<, U>, U>>
frequency	tripping values in Hz	<SELECT/RESET><+><> one time for each phase	L1, L2, L3 U<, U<<, U>, U>>
rate of change of frequency	tripping value in Hz/s	<SELECT/RESET><+><>	f, f_1 , f_2 , f_3 df
Save parameter?	SAV?	<ENTER>	
Save parameter!	SAV!	<ENTER> for about 3 s	
Software version	First part (e.g. D02-) Sec. part (e.g. 6.01)	<TRIP> one time for each part	
Manual trip	TRIP?	<TRIP> three times	
Inquire password	PSW?	<SELECT/RESET>/ <+>/<>/<ENTER>	
Relay tripped	TRIP	<TRIP> or fault tripping	
Secret password input	XXXX	<SELECT/RESET>/ <+>/<>/<ENTER>	
System reset	SEG	<SELECT/RESET> for about 3 s	

Table 3.1: possible indication messages on the display

3.2.3 LEDs

All LEDs (except LED RS, min and max) are two-coloured. The LEDs on the left side, next to the alpha-numerical display light up green during measuring and red after tripping.

The LEDs below the push button <SELECT/RESET> are lit green during setting and inquiry procedure of the setting values which are printed on the left side next to the LEDs. The LEDs will light up red after activation of the setting values next to their right side.

The LED marked with letters RS lights up during setting of the slave address of the device for serial data communication.

3.2.4 Front plate XRW1

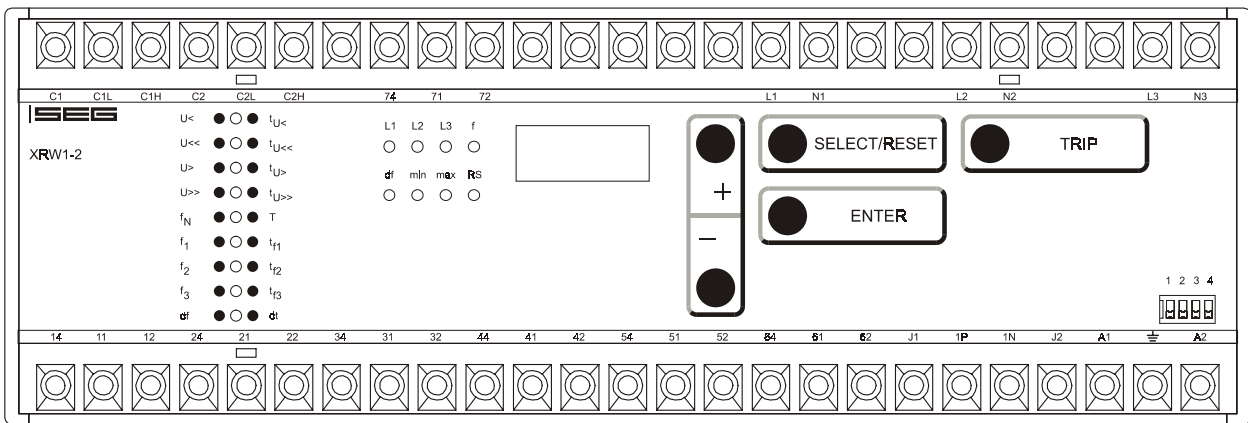

3.2.5 Parameter settings

Setting parameters		Unit	Range
Δ/Y	input transformer connection		Y = star DELTA = Delta
$U_{<}$	pickup value for undervoltage element (low set)	V	0 - 800
$t_{U<}$	tripping delay for undervoltage element	s	0.04 - 50
$U_{<<}$	pickup value for undervoltage element (high set)	V	0 - 800
$t_{U<<}$	tripping delay for undervoltage element	s	0.04 - 50
$U_{>}$	pickup value for overvoltage element (low set)	V	0 - 800
$t_{U>}$	tripping delay for overvoltage element	s	0.04 - 50
$U_{>>}$	pickup value for overvoltage element (high set)	V	0 - 800
$t_{U>>}$	tripping delay for overvoltage element	s	0.04 - 50
f_N	rated frequency	Hz	50/60
T	frequency measuring repetition in periods	cycles	2 - 99
f_1	pickup value for frequency element 1	Hz	30 - 70 or 40 - 80
t_{f1}	tripping delay for frequency element 1	s	t_{tmin} -50
f_2	pickup value for frequency element 2	Hz	30 - 70 or 40 - 80
t_{f2}	tripping delay for frequency element 2	s	t_{tmin} -50
f_3	pickup value for frequency element 3	Hz	30 - 70 or 40 - 80
t_{f3}	tripping delay for frequency element 3	s	t_{tmin} -50
df	pickup value for rate of frequency (dt/dt) in	Hz/s	0,2 - 10
dt	measuring repetition for df/dt	periods	2 - 64
$U_{B<}$	voltage threshold value for frequency and vector surge measuring (or df/dt)	V	20 - 400
RS	Slave address of the serial interface		1 - 32

Table 3.2: Sequence of parameter setting

4 Working principle

4.1 Analog circuits

The input voltages are galvanically insulated by the input transformers. The noise signals caused by inductive and capacitive coupling are suppressed by an analog R-C filter circuit.

The analog voltage signals are fed to the A/D-converter of the microprocessor and transformed to digital signals through Sample- and Hold- circuits. The analog signals are sampled with a sampling frequency of $16 \times f_N$, namely, a sampling rate of 1.25 ms for every measuring quantity, at 50 Hz.

4.2 Digital circuits

The essential part of the *XRW1* relay is a powerful microcontroller. All of the operations, from the analog digital conversion to the relay trip decision, are carried out by the microcontroller digitally. The relay program is located in an EPROM (Electrically-Programmable-Read-Only-Memory). With this program the CPU of the microcontroller calculates the three phase voltage in order to detect a possible fault situation in the protected object.

For the calculation of the voltage value an efficient digital filter based on the Fourier Transformation (DFFT - Discrete Fast Fourier Transformation) is applied to suppress high frequency harmonics and d.c. components caused by fault-induced transients or other system disturbances. The microprocessor continuously compares the measured values with the preset thresholds stored in the parameter memory (EEPROM). If a fault occurs an alarm is given and after the set tripping delay has elapsed, the corresponding trip relay is activated.

The relay setting values for all parameters are stored in a parameter memory (EEPROM - Electrically Erasable Programmable Read Only Memory), so that the actual relay settings cannot be lost, even if the power supply is interrupted.

The microprocessor is supervised by a built-in "watchdog" timer. In case of a failure the watchdog timer resets the microprocessor and gives an alarm signal via the output relay "self supervision".

4.3 Voltage supervision

The voltage element of *XRW1* has the application in protection of generators, consumers and other electrical equipment against over/and undervoltage.

The relay is equipped with a two step independent three-phase overvoltage ($U>$, $U>>$) and undervoltage ($U<$, $U<<$) function with completely separate time and voltage settings.

In delta connection the phase-to-phase voltages and in star connection the phase-to-neutral voltages are continuously compared with the preset thresholds.

For the overvoltage supervision the highest, for the undervoltage supervision of the lowest voltage of the three phases are decisive for energizing.

4.3.1 Selection of star or delta connection

All connections of the input voltage transformers are led to screw terminals. The nominal voltage of the device is equal to the nominal voltage of the input transformers. Dependent on the application the input transformers can be connected in either delta or star. The connection for the phase-to-phase voltage is the delta connection. In star connection the measuring voltage is reduced by $1/\sqrt{3}$. During parameter setting the connection configuration either Y or Δ has to be adjusted.

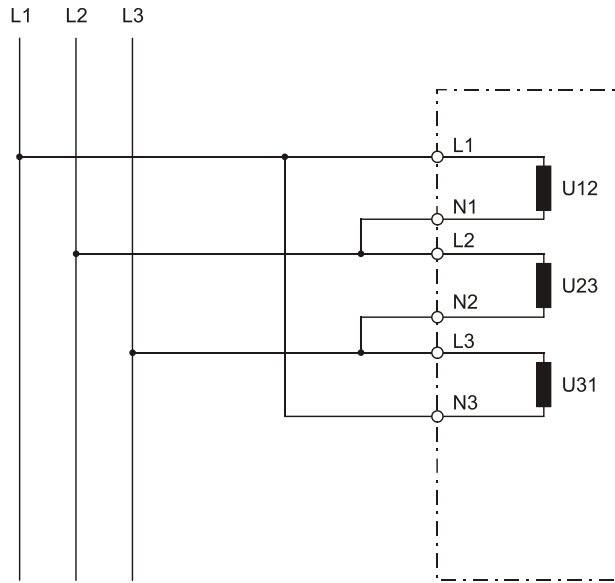

Fig. 4.1: Input v.t.s in delta connection (Δ)

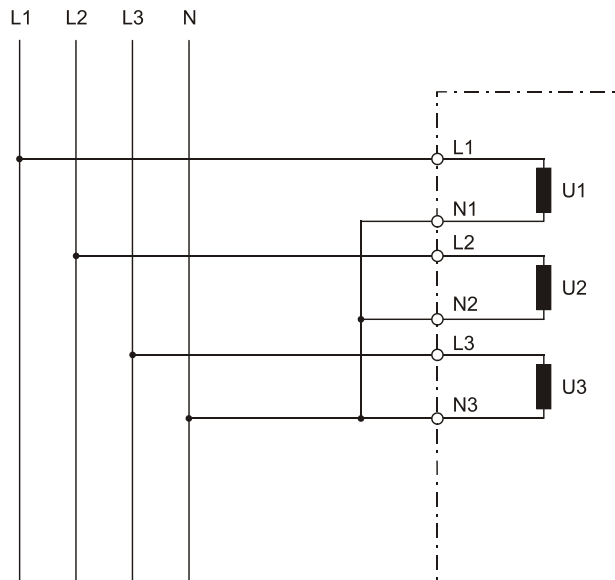

Fig. 4.2: Input v.t.s in star connection (Y)

4.4 Principle of frequency supervision

The frequency element of *XRW1* protects electrical generators, consumers or electrical operating equipment in general against over- or underfrequency.

The relay has independent three frequency elements $f_1 - f_3$ with a free choice of parameters, with separate adjustable pickup values and delay times.

The measuring principle of the frequency supervision is based in general on the time measurement of complete cycles, whereby a new measurement is started at each voltage zero passage. The influence of harmonics on the measuring result is thus minimized.

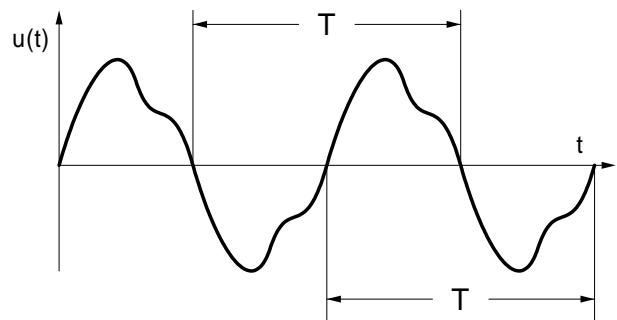

Fig. 4.3: Determination of cycle duration by means of zero passages.

In order to avoid false tripping during occurrence of interference voltages and phase shifts the relay works with an adjustable measuring repetition (see chapter 6.2.3)

Frequency tripping is sometimes not desired by low measured voltages which for instance occur during alternator acceleration. All frequency supervision functions can be blocked with the aid of an adjustable voltage threshold U_g in case the measured voltage value is below this value.

4.5 Measuring of frequency gradient

Electrical generators running in parallel with the mains, e.g. industrial internal power supply plants, should be separated from the mains when failure in the intrasystem occurs for the following reasons:

- It must be prevented that the electrical generators are damaged when mains voltage recovering asynchrone, e.g. after a short interruption.
- The industrial internal power supply must be maintained.

A reliable criterion of detecting mains failure is the measurement of the rate of change of frequency df/dt . Precondition for this is a load flow via the mains coupling point. At mains failure the load flow changing then spontaneously leads to an increasing or decreasing frequency. At active power deficit of the internal power station a linear drop of the frequency occurs and a linear increase occurs at power excess. Typical frequency gradients during application of "mains decoupling" are in the range of 0.5 Hz/s up to over 2 Hz/s. The **XRW1** detects the instantaneous frequency gradient df/dt of each mains voltage period in an interval of one half period each. Through multiple evaluation of the frequency gradient in sequence the continuity of the directional change (sign of the frequency gradient) is determined. Because of this special measuring procedure a high safety in tripping and thus a high stability against transient processes, e.g. switching procedure are reached. The total switching off time at mains failure is between 60 ms and 80 ms depending on the setting.

4.6 Voltage threshold value for frequency measuring

At low measuring voltages, e.g. during generator start-up, frequency and df/dt -measuring is perhaps not desired.

By means of the adjustable voltage threshold value $U_{b<}$, functions $f_1 - f_3$ and df/dt are blocked if the measured voltage falls below the set value.

4.7 Blocking function

No.	Dynamic Behaviour	$U_{<}<<$	$U_{>>>$	f_1, f_2, f_3	df/dt
1	voltage to external blocking input is applied	free programmable	free programmable	free programmable	free programmable
2	blocking input is released	released instantaneously	released instantaneously	released after 1 s	released after 5 s
3	supply voltage is switched on	blocked for 200 ms	blocked for 200 ms	blocked for 1 s	blocked for 1 s
4	3ph measuring volt. is suddenly applied	released	released	blocked for 1 s	blocked for 5 s
5	one or several measuring voltages are switched off suddenly (phase failure)	released	released	blocked	blocked
6	measuring voltage smaller $U_{b<}$ (adjustable voltage threshold value)	released	released	blocked	blocked

Table 4.1: Dynamic behaviour of *XRW1* functions

Blocking function set in compliance with requirements:

The *XRW1* has an external blocking input. By applying the auxiliary voltage to input C1/C1L or C1/C1H, the requested protection functions of the relay are blocked.

5 Operation and setting

For adjustment of the unit the transparent cover has to be opened as illustrated. Do not use force! The transparent cover has two inserts for labels.

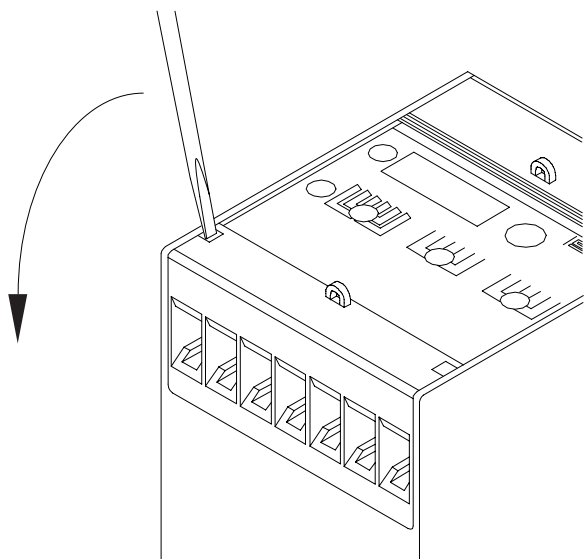

Fig. 5.1: How to open the transparent cover

5.1 Push buttons

Push buttons are used for calling up the parameters to be processed, for selection of measuring parameters to be indicated and for changing and storing the parameters.

The individual setting and measuring values can be selected one after another by pressing push button <SELECT/RESET>. This push button is also used for resetting the display by pressing approx. 3s.

Push buttons <+> <-> are used for in-/decrementing of the parameter indicated on the display. They can be pressed step-by-step or continuously.

After the selected parameter is set by the <+> <-> push button it may be stored using the <ENTER> push button.

Through the push button <ENTER> the set value indicated on the display will be transferred to the internal parameter memory. An unintended or unauthorized change of the selected parameter is avoided by means of a password identification (see 5.4.2).

The <TRIP>-push button is used to test the output relay circuits both for tripping and signalling. During normal operation it is also interlocked by means of the password identification.

5.1.1 Indication of measuring values and fault data

Indication in faultless condition

In normal operation the display always shows |SEG. After pressing the push button <SELECT/RESET> the display switches cyclically to the next measuring value. After the measuring values had been indicated the setting parameters are displayed. Hereby the LEDs in the upper section signalize which measured value is indicated, the LEDs in the lower section signalize which setting parameter is indicated on the display. Longer actuating the push button resets the relay and the display changes into normal operation (|SEG).

Indication after pickup / tripping

All of the faults detected by the relay are indicated on the front plate optically. Here not only the faults are indicated but also the faulty phase(s) and the protection function in operation. During the excitation phase LEDs are flashing, after tripping this changes to continuous light.

In tripped condition "TRIP" appears on the display and the LEDs of the operating measuring data light up red together with the LEDs of the tripping parameter. All operating data, which were measured at the moment of tripping, can now be called one after another by pressing push button <SELECT/RESET>. If in this condition setting parameters are to be indicated, push button <ENTER> has to be pressed.

The graphic below shows again the difference between the different display modes.

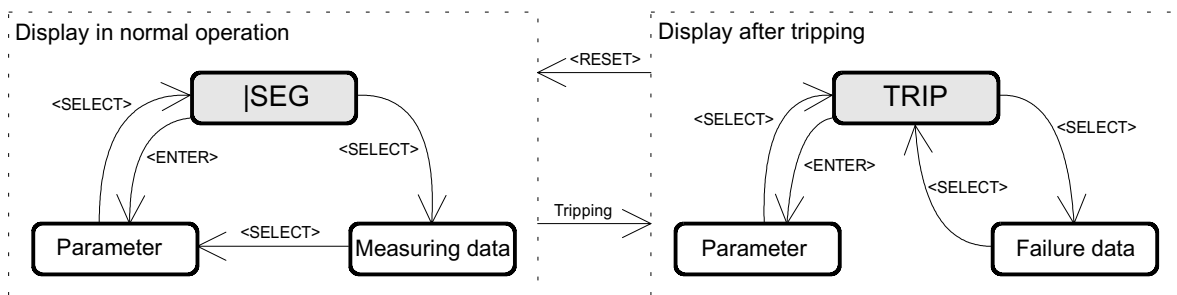

Fig. 5.2: Switching over of the display in dependence of the operating mode.

5.2 DIP switches

On the front plate of the *XRW1*-relay there is one DIP switch to preset the following functions:

- Password programming
- Output relay functions

5.2.1 Function of the output relays

The following functions of the output relays can be preset:

- Alarm relay activation at pickup or after tripping of the relay
- Reset of the output relays manually or automatically

The alarm relays are activated according to the presetting:

Dip switch 2 OFF:

The alarm relays pickup directly with energizing of the corresponding measuring circuit. Thus, an alarm signalling can be given before the relay trips.

Dip switch 2 ON:

The alarm relays pickup only after relay trip. That means: the trip relay and the corresponding alarm relay pickup at the same time after the time delay elapsed.

Dip switch 3 OFF:

All output relays will be reset automatically after the fault has been rectified, (e.g. when the fault current is interrupted).

Dip switch 3 ON:

All output relays remains activated and must be reset after fault clearance.

- Manually: By pressing push button <SELECT/RESET>
- External: By connecting aux. voltage to C2/C2L or C2/C2H
- Via RS 485 interface

To let the parameter change take effect, the auxiliary voltage has to be switched on and off again after the dip switches are plugged or unplugged.

Dip switch	Function	Dip switch position	Operation mode
1	Password	OFF	Normal position
		ON	Password selection
2	Alarm relays	OFF	Alarm relays will be activated at pickup
		ON	Alarm relay will be activated at tripping
3	Reset	OFF	Output relays will be reset automatically
		ON	Output relays will be reset manual/external/via software
4	none		

Table 5.1: Summary of coding possibilities

Note

After the DIP switches have been changed, the auxiliary voltage has to be disconnected for about 3 seconds so the new positions can be taken over.

5.3 Reset

Manual reset

By pressing push button <RESET/SELECT> for some time (about 3 s).

External reset-input C2/C2L or C2/C2H

The external reset input has the same function as the <SELECT/RESET> push button on the front plate. Connecting auxiliary voltage to this input, the unit can be reset, provided that the fault is removed.

Software reset via serial interface RS 485

Software reset has the same function as push button <SELECT/RESET>. Please refer to open data protocol of RS 485 interface named RS485-PRO.

5.4 Password

5.4.1 Password programming

The *XRW1*-relay is delivered with the preset password "++++", it can be programmed new with dip switch 1:

Apply dip switch 1. After power on and pressing any push button, the relay *XRW1* inquires for a new password. The text "PSW?" appears on the display. The new password is entered by any combination of the push buttons <SELECT> <-> <+> <ENTER>. After the new password is given, the dip switch 1 has to be removed.

5.4.2 Using the password

Step by step, a new relay setting is made according to the following sequence:

- After the present setting value is changed with <+><-> push button, <ENTER>-push button should be pressed.
- A message "SAV?" appears on the display to inquire if the new setting value is really wanted to be stored.
- After pressing the <ENTER>-push button again, the password will be inquired by means of the message "PSW?" on the display.
- After the password is given correctly, which is prompted by message "SAV!" on the display, the new setting value can be stored by pressing the <ENTER>-push button for about 3 seconds.
- The new setting value for the selected parameter appears on the display again.

A password consists of four push button operations. The pressed push buttons and their sequences define the password.

<SELECT> = S
<-> = -
<+> = +
<ENTER> = E

then a password "-E+S" means pressing push buttons according to the following sequence:

<-> <ENTER> <+> <SELECT>

After the password is given correctly, parameter setting is permitted for five minutes. This means: For a subsequent parameter setting, as long as it is made within five minutes after the password input, a renewed password input is not required. Moreover, the valid period for parameter setting is automatically extended to further 5 minutes after each new push button operation.

If no push button operation follows within the five minute period after password input, the validity for parameter setting will be suspended.

For entering further parameters the password is then called up again. During the validity for parameter setting a new set value, after having acknowledged "SAV" two times, is stored by just pressing push button <ENTER> for some time.

As to parameter setting via RS 485 interface: see open data protocol.

5.5 Relay setting principle

By pressing push button <ENTER>, the parameter menu can be called up. By pressing push button <SELECT/RESET> the parameter to be set is reached. The corresponding LED lights up. The actual set value of the selected parameter is indicated on the display. The indicated set value can then be changed by pressing push buttons <+><-> (in-/decrementing). The selected set value is stored by pressing push button <ENTER> and by input of the authority code (password) which means the adjustment of the unit is only possible after the password had been put in. (see 5.4.2)

After a trip the push button <SELECT/RESET> is reserved for the indication of fault data. Now new parameter setting by means of push button <SELECT/RESET> is only possible by pressing <ENTER> first.

5.5.1 Setting of default parameters

Setting of the *XRW1* default parameters can be done as follows:

- switch off the auxiliary voltage supply
- press simultaneously push buttons <+><-> and <SELECT/RESET> and
- switch on the auxiliary voltage supply again.

5.5.2 Blocking the protection functions

The blocking function of the *XRW1*-relays can be set according to requirement. When pressing push buttons <ENTER> and <TRIP> at the same time the blocking mode is entered.

5.6 Display of software version and test-TRIP

By pressing push button <TRIP> the first part of the software version is displayed, the second part appears when this push button is pressed again. When push button <TRIP> is pressed repeatedly, the test trip routine starts.

By entering the password the display shows "TRI?". After pressing <TRIP> again all output relays will be energized one after the other with a time delay of 1 s.

All relays stay energized until manual reset. The protection functions are not affected.

5.7 Low/High range of functions blocking and reset

All relays of the *PROFESSIONAL LINE* have a wide-range power supply unit allowing to choose a suitable supply voltage. The operating threshold of the blocking and reset inputs, however, has to be defined by taking the supply voltage into account. The following two different operating thresholds are available:

- Low-range threshold $U_{AN} \geq 10 \text{ V}$; $U_{AB} \leq 8 \text{ V}$
- High-range threshold $U_{AN} \geq 70 \text{ V}$; $U_{AB} \leq 60 \text{ V}$

Connection terminals

- Low-range blockage input terminal C1/C1L
- Low-range reset input terminal C2/C2L
- High-range blockage input terminal C1/C1H
- High-range reset input terminal C2/C2H

6 Special settings

6.1 Adjustable parameters

The following parameters can be set by the user himself:

Δ/Y	-	changing of input transformer connection
$U<$	-	threshold for undervoltage
$t_{U<}$	-	tripping delay for undervoltage
$U<<$	-	threshold for undervoltage
$t_{U<<}$	-	tripping delay for undervoltage
$U>$	-	threshold for overvoltage
$t_{U>}$	-	tripping delay for overvoltage
$U>>$	-	threshold for overvoltage
$t_{U>>}$	-	tripping delay for overvoltage
f_N	-	rated frequency
T	-	frequency measuring repetition in periods
f_1	-	threshold for frequency element 1
t_{f1}	-	tripping delay for frequency element 1
f_2	-	threshold for frequency element 2
t_{f2}	-	tripping delay for frequency element 2
f_3	-	threshold for frequency element 3
t_{f3}	-	tripping delay for frequency element 3
$U_B<$	-	voltage threshold value for frequency and vector surge measuring (or df/dt)
RS	-	Slave address of the serial interface
df	-	threshold for rate of frequency (df/dt) in Hz/s
dt	-	measuring repetition for df/dt in periods

6.2 Setting procedure

In this paragraph the settings for all relay parameters are described in detail. For parameter setting a password has to be entered first (please refer to 5.4).

6.2.1 Parameter setting of over- and undervoltage supervision

The setting procedure is guided by two coloured LEDs. During setting of the voltage thresholds the LEDs $U<$, $U<<$, $U>$ and $U>>$ are light green. During setting of the trip delays $t_{U>}$, $t_{U>>}$, $t_{U<}$ and $t_{U<<}$ the according LEDs light up red.

Thresholds of the voltage supervision

During setting of the threshold $U>$, $U>>$, $U<$ and $U<<$ the displays shows the value directly in volt. The thresholds can be changed by the $<+>$ $<->$ push buttons and stored with $<ENTER>$.

The undervoltage supervision ($U<$ and $U<<$) as well as the overvoltage supervision ($U>$ and $U>>$) can be deactivated by setting the threshold to "EXIT".

Tripping delay of voltage supervision

During setting of the tripping delays $t_{U<}$, $t_{U<<}$, $t_{U>}$ and $t_{U>>}$ the display shows the value directly in seconds. The tripping delay is changed via the push button $<+>$ and $<->$ in the range of 0,04 s to 50 s and can be stored with the push button $<ENTER>$.

When setting the tripping delay to "EXIT" the value is infinit meaning only warning, no tripping.

6.2.2 Setting of nominal frequency

First the nominal frequency (50 or 60 Hz) has to be correctly set before unit *XRW1* is put into operation. All frequency functions are determined by setting the nominal frequency, i.e. whether the set frequency thresholds are evaluated as over- or underfrequency (see also chapter 6.2.4). Also the cycle duration (20 ms at 50 Hz and 16.67 ms at 60 Hz) derives from this setting which determines the minimum tripping delay for frequency elements $f_1 - f_3$ with an adjustable multiplier (see also chapter 6.2.5). During setting of the nominal frequency a value in Hz is shown on the display.

6.2.3 Number of measuring repetitions (T) for frequency functions

In order to avoid false tripping of the unit at short voltage drops of the system voltage or interference voltages, *XRW1* works with an adjustable measuring repetition. When the instantaneous frequency measuring value exceeds (at overfrequency) or falls below (at underfrequency) the set reference value, the counter is incremented, otherwise the counter is decremented down to the minimum value of 0. Only when the counter exceeds the value adjusted at T, alarm is given and after the tripping delay of the frequency element has elapsed the tripping command is given. The setting range for T is between 2 - 99.

Recommendation for setting:

For short tripping times, e.g. for machine protection or for mains decoupling T should be set in the range from 2 - 5.

At precision measurements, e.g. exact measurement of the system frequency a setting of T in the range from 5 - 10 is recommended.

6.2.4 Threshold of frequency supervision

The frequency supervision of *XRW1* has three frequency elements independent from each other. Acc. to setting the pickup value above or below the nominal frequency, these elements can be used for over- or under frequency supervision.

Dependent on the preset nominal frequency f_N the pickup values from 30 Hz up to 70 Hz at $f_N = 50$ Hz and from 40 Hz to 80 Hz at $f_N = 60$ Hz can be set. During setting of the pickup values $f_1 - f_3$ the display shows the values in Hz. A value of for instance 49,8 Hz is indicated with "4980".

The function of the individual frequency elements can be deactivated by setting the pickup values to "EXIT". The setting value "EXIT" corresponds to the rated frequency.

6.2.5 Tripping delays for the frequency elements

Tripping delays $t_{f1} - t_{f3}$ of the three frequency elements can independently be set from $t_{f,min} - 50$ s. The minimum tripping delay $t_{f,min}$ of the relay is dependent upon the number of set measuring repetitions T (periods) and amounts to:

$$t_{f,min} = (T+1) \cdot 20 \text{ ms}$$

When setting the tripping delay to "EXIT" by pressing push button <+> up to the maximum setting value, the corresponding tripping relay is blocked. Pickup of the frequency element is however displayed on the front plate by the corresponding LED, an alarm relay is also activated.

6.2.6 Parameter setting of frequency gradient

The pickup value of frequency gradient (parameter df) can be set between 0.2 to 10 Hz/s. The number of measuring repetitions (parameter dt) can be set between 2 - 64 cycles. This parameter defines the number of df/dt measurements, which have to exceed the set value, before tripping.

Setting information:

The power difference after mains failure causes a change in frequency, which can approximately be calculated as follows:

$$\frac{df}{dt} = -\frac{f_N}{T_A} \cdot \Delta P$$

with

f_N = rated frequency in Hz

T_A = inertia time constant of the generators

ΔP = per unit power deficit with reference to the rated active power of the generators

If the inertia time constant is known and a power difference given, the frequency gradient can be estimated by the a.m. equation. At a supposed power difference of 20% and an inertia time constant of 10 s, the frequency gradient is 1 Hz/s.

To prevent false trippings at loading, deloading or failure signals, we would recommend a setting value for dt of minimum 4 cycles.

6.2.7 Voltage threshold value for frequency and df/dt measuring

Correct frequency measuring or vector surge measuring cannot be obtained if the system voltage is very low, for instance during generator start up or voltage failure. False tripping of the *XRW1* in such cases is prevented by an adjustable voltage threshold U_b . If the system voltage is below this threshold, these functions of the relay are blocked.

During adjustment of U_b LEDs f and df light up in the right display part.

6.2.8 Adjustment of the slave address

By pressing push buttons <+> and <-> the slave address can be set in the range of 1 - 32. During this adjustment the LED RS lights up.

6.2.9 Setting procedure for blocking the protection functions

The blocking function of the *XRW1* can be set according to requirement. By applying the aux. voltage to C1/C1L or C1/C1H, the functions chosen by the user are blocked. Setting of the parameter should be done as follows:

- When pressing push buttons <ENTER> and <TRIP> at the same time, message "BLOC" is displayed (i.e. the respective function is blocked) or "NO_B" (i.e. the respective function is not blocked). The LED allocated to the first protection function U< lights red.
- By pressing push buttons <+> <-> the value displayed can be changed.
- The changed value is stored by pressing <ENTER> and entering the password.
- By pressing the <SELECT/RESET> push button, any further protection function which can be blocked is displayed.
- Thereafter the menu is left by pressing <SELECT/RESET> again.

6.3 Indication of measuring values

In normal operation the following measuring values can be displayed:

Voltages (LED L1, L2, L3 green)

- In star connection all phase-to-neutral voltages
 - In delta connection all phase-to-phase voltages
- Frequency (LED f green + L1, L2 or L3 green);
Frequency gradient df/dt (LED df green)

Min. and max. values prior to the last reset :

- Frequency (LED f + min or f + max)
- Frequency gradient (LED df + min or df + max)

6.3.1 Min./Max.- values

The *XRW1* offers a minimum/maximum storage for the measuring values of the frequency gradient. These min./max. values are mainly used to appraise the system quality. Always the highest and lowest values of **each cycle** are measured and stored until the next reset.

Min./max. frequency measuring :

The *XRW1* ascertains the actual frequency from each cycle of the system voltage. These measuring values are entered into the min./max. storage. The latest entered min./max. values replace the previously stored values.

Dependent on the adjustment of dt and tripping delay, it is possible that the stored min./max. values are higher than the tripping threshold without causing a trip. The reason for this is storage of instantaneous values.

Min./Max. measuring of the frequency gradient :

The procedure described above applies also to storage of min./max. values of df/dt measurement. Since each instantaneous df/dt value is stored, high values can occur which, however, do not cause any tripping.

This can for instance happen during switching procedures where high positive and negative df/dt values occur, but they do not cause any tripping due to the special measuring method.

As to operation :

After each reset (ref. 6.4) the min./max. storages are cleared. As from this instant there is no time limit for the min./max. storage until the next reset.

By repeatedly pressing the <SELECT/RESET> push button, the measuring values of the min./max. storage can be queried. The respective LEDs light up at the same time; e.g. during minimum frequency is displayed, LEDs "f" and "min" light up.

6.4 Reset

All relays have the following three possibilities to reset the display of the unit as well as the output relay at switch position 3=ON.

Manual Reset

- Pressing the push button <SELECT/RESET> for some time (about 3 s)

Electrical Reset

- Through applying auxiliary voltage to C2/C2L or C2/C2H

Software Reset

- The software reset has the same effect as the <SELECT/RESET> push button (see also communication protocol of RS485 interface)

The display can only be reset when the pickup is not present anymore (otherwise "TRIP" remains in display).

During resetting of the display the parameters are not affected.

7 Relay testing and commissioning

The following test instructions should help to verify the protection relay performance before or during commissioning of the protection system. To avoid a relay damage and to ensure a correct relay operation, be sure that:

- the auxiliary power supply rating corresponds to the auxiliary voltage on site.
- the rated frequency and rated voltage of the relay correspond to the plant data on site.
- the voltage transformer circuits are connected to the relay correctly.
- all signal circuits and output relay circuits are connected correctly.

7.1 Power-On

NOTE!

Prior to switch on the auxiliary power supply, be sure that the auxiliary supply voltage corresponds to the rated data on the type plate.

Switch on the auxiliary power supply to the relay and check that the message "ISEG" appears on the display and the self supervision alarm relay (watchdog) is energized (terminals 71 and 74 closed).

It may happen that the relay is tripped because of under voltage condition after power-on. (The message "TRIP" on the display and LED L1, L2, L3 and U< light up red). An undervoltage condition has been detected after power-on, because no input voltages are applied to the relay. In this case:

- Press the push button <ENTER>, thus entering into the setting mode. Now set the parameters U< and U<< to "EXIT" to block the undervoltage functions. After that, press the <SELECT/RESET> for app. 3 s to reset the LEDs and "TRIP" message.
- The undervoltage tripping after power on can also be eliminated by applying three phase rated voltages after power-on and reset the LED and "TRIP" message.
- Apply auxiliary voltage to the external blocking input (Terminals C1/C1L or C1/C1H) to inhibit the undervoltage functions (refer to 6.2.10) and press the <SELECT/RESET> for app. 3 s to reset the LEDs and "TRIP" message.

7.2 Testing the output relays

NOTE!

Prior to commencing this test, interrupt the trip circuit to the circuit breaker if tripping is not desired.

By pressing the push button <TRIP> once, the display shows the first part of the software version of the relay (e.g. „D08-“). By pressing the push button <TRIP> twice, the display shows the second part of the software version of the relay (e.g. „4.01“). The software version should be quoted in all correspondence. Pressing the <TRIP> button once more, the display shows "PSW?". Please enter the correct password to proceed with the test. The message "TRI?" will follow. Confirm this message by pressing the push button <TRIP> again. All output relays should then be activated and the self supervision alarm relay (watchdog) be deenergized one after another with a time interval of 1 second. Thereafter, reset all output relays back to their normal positions by pressing the push button <SELECT/RESET>.

7.3 Checking the set values

By repeatedly pressing the push button <SELECT>, all relay set values may be checked. Set value modification can be done with the push button <+><-> and <ENTER>.

As relay input energizing quantities, three phase voltages should be applied to **XRW1** relay input circuits. Depending on the system conditions and the voltage transformer used, three voltages can be connected to the relay input circuits with either star or delta connection. In case of a star connection the phase-to-neutral voltage will be applied to the voltage input circuits, while the phase-to-phase voltages will be connected to the voltage input circuits in case of a delta connection. The voltage input connection must be set as a parameter, and should correspond with the actual voltage input connection:

Star connection: Phase-to-neutral voltages will be measured and evaluated.

Delta connection: Phase-to-phase voltages will be measured and evaluated.

7.4 Secondary injection test

7.4.1 Test equipment

- Voltmeter and frequency meter with class 1 or better
- Auxiliary power supply with the voltage corresponding to the rated data on the type plate
- Three-phase voltage supply unit with frequency regulation (Voltage: adjustable from 0 to $\geq 2 \times U_{N1}$; Frequency: adjustable from 40 - 70 Hz)
- Timer to measure the operating time (Accuracy class ± 10 ms)
- Switching device
- Test leads and tools

7.4.2 Example of test circuit

For testing of the *XRW1* relay, a three phase voltage source with adjustable voltage and frequency is required. Figure 7.1 shows an example of a three-phase test circuit energizing the *XRW1* relay during test. The three phase voltages are applied to the relay in Y-connection.

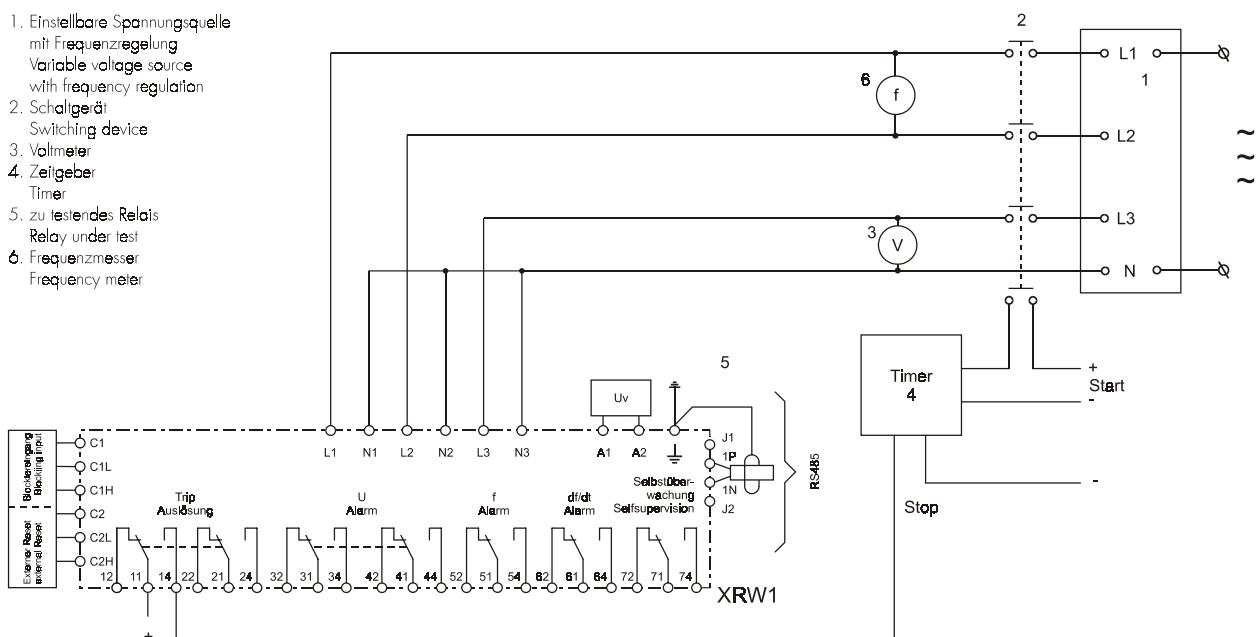

Fig. 7.1: Test circuit

For testing the df/dt function of the relay, a special test equipment is required, which produces a constant rate of change of frequency.

7.4.3 Checking the input circuits and measuring functions

Apply three voltages of rated value to the voltage input circuits (terminals L1, L2, L3, N1, N2, N3) of the relay. Check the measured voltages, frequency and the rate of change of frequency on the display by pressing the push button <SELECT/RESET> repeatedly.

The voltages are indicated on the display in volts
At Y-connection:

- Phase-to-neutral voltages: LED L1, L2, L3

At Delta-connection:

- Phase-to-phase voltages: LED L1+L2, L2+L3, L3+L1

The frequency is indicated on the display in Hz: LED f (system frequency = 50.01Hz, Indication = 5001)

The rate of change of frequency (LED df) is indicated on the display in Hz/s.

Change the voltages around the rated value and check the measured voltages on the display.

Change the system frequency around the rated frequency and check the measured frequency on the display.

Compare the voltage and frequency on display with the signal on voltmeter and frequency meter. The deviation for the voltage must not exceed 1% and for frequency <0.01 Hz.

By using an RMS-metering instrument, a greater deviation may be observed if the test voltage contains harmonics. Because the XRW1 relay measures only the fundamental component of the input signals, the harmonics will be rejected by the internal DFFT-digital filter. Whereas the RMS-metering instrument measures the RMS-value of the input signals.

7.4.4 Checking the operating and resetting values of the over/undervoltage functions

Note:

When the measuring voltage is connected or disconnected, df/dt tripping can occur. In order to ensure a trouble-free test procedure, the df/dt function of the relay have to be blocked before tests are started.

Apply three voltages with the rated value and gradually increase (decrease) the voltages until the relay starts, i.e. at the moment when the LED U> (or U<) lights up or the voltage alarm output relay (contact terminals 31/34 and 41/44) is activated. Read the operating voltage indicated by the voltmeter. The deviation must not exceed 1% of the set operating value.

Furthermore, gradually decrease (increase) the voltages until the relay resets, i.e. the voltage alarm output relay is disengaged. Check that the dropout to pickup ratio for voltage is greater than 0.97 (for overvoltage function) or smaller than 1.03 (for undervoltage).

7.4.5 Checking the relay operating time of the over/undervoltage functions

To check the relay's operating time, a timer must be connected to the trip output relay contact (Contact terminals D1/E1). The timer should be started simultaneously with the voltage change from sound condition to a faulty condition and stopped by the trip relay contact. The operating time measured by timer should have a deviation about 3% of the set value or <20 ms.

7.4.6 Checking the operating and resetting values of the over/underfrequency functions

Note:

Due to frequency changes, vector surge tripping or df/dt tripping can occur during frequency tests. In order to ensure a trouble-free test procedure, the df/dt function of the relay have to be blocked before tests are started.

During frequency tests, each of the frequency elements should be tested separately. This makes it necessary that the other frequency elements of the relay have to be blocked by setting the frequency pickup values $f_1 - f_3$ to "EXIT". For testing the pickup and dropout to pickup values, the test frequency has to be increased (decreased) until the relay is energized. This is indicated by lighting up of LEDs $f_1 - f_3$.

When comparing the values displayed with those of the frequency meter, the deviation must not exceed 0.01 Hz. The dropout to pickup values are ascertained by increasing (decreasing) the test frequency slowly until the output relay releases.

The dropout to pickup value for overfrequency must be >0.99, and for underfrequency <1.01.

7.4.7 Checking the relay operating time of the over/underfrequency functions

The operating time of the over/underfrequency functions can be tested in the similar manner as in chapter 7.4.5 for over/undervoltage functions.

7.4.8 Checking the external blocking and reset functions

The external blocking input is free programmable by the user.

To test the blocking function apply auxiliary supply voltage to the external blocking input of the relay (terminals C1/C1L or C1/C1H). Inject a test voltage which could cause tripping for the testes functions. Observe that there is no trip and alarm for those functions.

Remove the auxiliary supply voltage from the blocking input. Apply test voltages to trip the relay (message „TRIP“ on the display). Return the test voltages to the sound condition and apply auxiliary supply voltage to the external reset input of the relay (terminals C2/C2L or C2/C2H). The display and LED indications should be reset immediately.

7.5 Primary injection test

Generally, a primary injection test could be carried out in the similar manner as the secondary injection test described above. With the difference that the protected power system should be, in this case, connected to the installed relays under test „on line“, and the test voltages should be injected to the relay through the voltage transformers with the primary side energized. Since the cost and potential hazards are very high for such a test, primary injection tests are usually limited to very important protective relays in the power system.

Because of its powerful combined indicating and measuring functions, the *XRW1* relay may be tested in the manner of a primary injection test without extra expenditure and time consumption.

In actual service, for example, the measured voltage and frequency values on the *XRW1* relay display may be compared phase by phase with the concerned indications of the instruments of the switchboard to verify that the relay works and measures correctly.

7.6 Maintenance

Maintenance testing is generally done on site at regular intervals. These intervals vary among users depending on many factors: e.g. the type of protective relays employed; the importance of the primary equipment being protected; the user's past experience with the relay, etc.

For electromechanical or static relays, maintenance testing will be performed at least once a year according to the experiences. For digital relays like *XRW1*, this interval can be substantially longer. This is because:

- the *XRW1* relays are equipped with very wide self-supervision functions, so that many faults in the relay can be detected and signalled during service. Important: The self-supervision output relay must be connected to a central alarm panel!
- the combined measuring functions of the *XRW1* relay enable supervision the relay functions during service.
- the combined TRIP test function of the *XRW1* relay allows to test the relay output circuits.

A testing interval of two years for maintenance will, therefore, be recommended.

During a maintenance test, the relay functions including the operating values and relay tripping times should be tested.

8 Technical data

8.1 Measuring input circuits

Rated data:	Nominal voltage U_N	690 V
	Nominal frequency f_N	40 - 70 Hz
Power consumption in voltage circuit:	<1 VA	
Thermal rating:	continuously	$1.15 \times U_N$
Undervoltage lockout for frequency and vector surge measurement:	$U <$ adjustable (5%...100% U_N)	

8.2 Common data

Dropout to pickup ratio:	for $U > / U >>$: >97%;	for $U < / U <<$: <103%
	for $f > / f >>$: >99.98%;	for $f < / f <<$: <100.02%
Dropout time:	60 ms	
Time lag error class index E:	± 10 ms	
Minimum operating time:	40 ms	
Max. allowed interruption of the auxiliary supply without affecting the function of the device:	50 ms	
Influences on voltage measuring:		
Aux. voltage:	in the range $0.8 < U_H / U_{HN} < 1.2$ no additional influences to be measured	
Frequency:	in the range $0.8 < f / f_N < 1.4$ (for $f_N = 50$ Hz) <0.15% / Hz	
Harmonics:	up to 20% of the 3rd harmonic <0.1% per percent of the 3rd harmonic up to 20% of the 5th harmonic <0.05% per percent of the 5th harmonic	
Influences on frequency measuring:		
Aux. voltage:	in the range $< 0.8 U_N / U_{HN} < 1.2$ no additional influences to be measured	
Frequency:	no influences	
Influences on delay time:	no additional influences to be measured	

8.3 Setting ranges and steps

Function	Parameter	Setting range	Steps	Tolerance
U</<<	U</<< t _{U<} t _{U<<}	U _N = 690 V: 4...800 V (EXIT) 0.04...50 s (EXIT)	2 V 0.01; 0.02; 0.05; 0.1; 0.2; 0.5; 1.0; 2.0 s	±1% or ±15 ms
U>/>>	U>/>> t _{U>} t _{U>>}	U _N = 690 V: 4...800 V (EXIT) 0.04...50 s (EXIT)	2 V 0.01; 0.02; 0.05; 0.1; 0.2; 0.5; 1.0; 2.0 s	±1% or ±15 ms
Rated frequency	f _N	f = 50 Hz / f = 60 Hz		
Frequency measuring repetition	T	2...99 (Cycles)	1	
Frequency element 1 - 3	f ₁ - f ₃ t _{f1} - t _{f3}	30...49.99; EXIT; 50.01...70 Hz ¹ 40...59.99; EXIT; 60.01...80 Hz ² t _{f,min} ³ ...50 s; EXIT	0.1; 0.01 Hz 0.01; 0.02; 0.05; 0.1; 0.2; 0.5; 1.0; 2.0 s	0.005 Hz ±1% or ±20 ms
df/dt-Step	df	0.2...10 Hz/s (EXIT)	0.1; 0.2; 0.5 Hz/s	0.1 Hz/s
df/dt-Measuring repetition	dt	2...64 Periods	1	
Voltage threshold for frequency measuring	U _{B<} (LED f+ df)	U _N = 100 V: 5...100 V U _N = 230 V: 12...230 V U _N = 400 V: 20...400 V	1 V 1 V 2 V	±1% of set value or <0.3% U _N
Serial Interface	RS	1 - 32	1	

Table 7.1: Setting ranges and steps

¹ At 50 Hz rated frequency

² At 60 Hz rated frequency

³ t_{f,min} min. time delay; t_{f,min} = (T+1) · 20 ms

8.4 Output relays

Relay type	Trip relays / change-over contacts	Alarm relays / change-over contacts
XRW1	1/2	1/2
		3/1

Table 7.2: Output relays

The output relays have with the following characteristics:

maximum breaking capacity 250 V AC / 1500 VA / continuous current 6 A

for DC voltage:

	ohmic	L/R = 40 ms	L/R = 70 ms
300 V DC	0.3 A / 90 W	0.2 A / 63 W	0.18 A / 54 W
250 V DC	0.4 A / 100 W	0.3 A / 70 W	0.15 A / 40 W
110 V DC	0.5 A / 55 W	0.4 A / 40 W	0.2 A / 22 W
60 V DC	0.7 A / 42 W	0.5 A / 30 W	0.3 A / 17 W
24 V DC	6 A / 144 W	4.2 A / 100 W	2.5 A / 60 W

Max. rated making current:

64 A (VDE 0435/0972 and IEC 65/VDE 0860/8.86)

Making current:

max 20 A (16 ms)

mechanical life span:

30×10^6 operating cycles

electrical life span:

2×10^5 operating cycles at 220 V AC / 6 A

Contact material:

silver cadmium oxide (AgCdO)

8.5 Power supply

Auxiliary voltage 16 - 360 V DC / 16 - 270 V AC

Power consumption:

standby 3 W operating 5 W

The connection terminals are C9, E9.

Max. allowed interruption of the auxiliary supply without effecting the function of the device:

50 ms

Propper connection of the earthing terminal \perp is essential for the EMC withstand of the relay.

Use wires of min. 1.5 mm².

8.6 Inputs, blockage and reset

Low-range:

For rated voltages

24 V, 48 V, 60 V

$U_{AN} \geq 10 \text{ V}$

$U_{AB} \leq 8 \text{ V}$

Current consumption

1 mA DC bei 24 V

High-range:

For rated voltages

100 V, 110 V, 125 V, 220 V, 230 V

$U_{AN} \geq 70 \text{ V}$

$U_{AB} \leq 60 \text{ V}$

Current consumption

1.5 mA DC 270 V or 11.0 mA AC

8.7 System data and test specifications

Design standards:	
Generic standard:	EN 50082-2, EN 50081-1
Product standard:	EN 60255-6, IEC 255-4, BS142
Specified ambient service recommended temperature for operation:	-10°C to +55°C
temperature limits:	in operation -25°C to +70°C in storage -25°C to +70°C
Moisture-carrying capacity class F as per DIN 40040 and per DIN IEC 68, part 2-3:	rel. humidity <95% at 40°C for 56 days
Insulation test voltage, inputs and outputs between themselves and to the relay frame as per EN 60255-6, IEC 255-5:	2.5 kV (eff.) / 50 Hz.; 1 min.
Impulse test voltage, inputs and outputs between themselves and to the relay frame as per EN 60255-6, IEC 255-5:	5 kV; 1.2 / 50 μ s, 0.5 J
High frequency interference test voltage, inputs and outputs between themselves and to the relay frame as per EN 60255-6, IEC 255-6:	2.5 kV / 1 MHz
Electrical discharge (ESD) test as per EN 61000-4-2, IEC 255-22-1:	8 kV air discharge, 6 kV contact discharge
Electrical fast transient (Burst) test as per EN 61000-4-8, IEC 255-22-1:	4 kV / 2.5 kHz, 15 ms
Power frequency magnetic field immunity test:	100 A/m continuously 1000 A/m for 3 s
Radiated electromagnetic field disturbance test as per ENV 50140, IEC 255-22-3:	electric field strength: 10 V/m
Guided radiated electromagnetic field disturbance test as per ENV 50141:	electric field strength: 10 V/m
Surge immunity test as per EN 61000-4-5: EN 61000-4-5:	4 kV
Radio interference suppression test as per EN 55011:	limit value class B
Radio interference radiation test as per EN 55011:	limit value class B

Mechanical test:

Shock:	Class 1 as per DIN IEC 255 T 21-2
Vibration:	Class 1 as per DIN IEC 255 T 21-1
Degree of protection:	IP40
Overvoltage class:	III
Weight:	1.6 kg
Relay case material:	self-extinguishing

Technical data subject to change without notice!

8.8 Relay case

Relay *XRW1* is designed to be fastened onto a DIN-rail acc. to DIN EN 50022, the same as all units of the *PROFESSIONAL LINE*.

The front plate of the relay is protected with a sealable transparent cover (IP40).

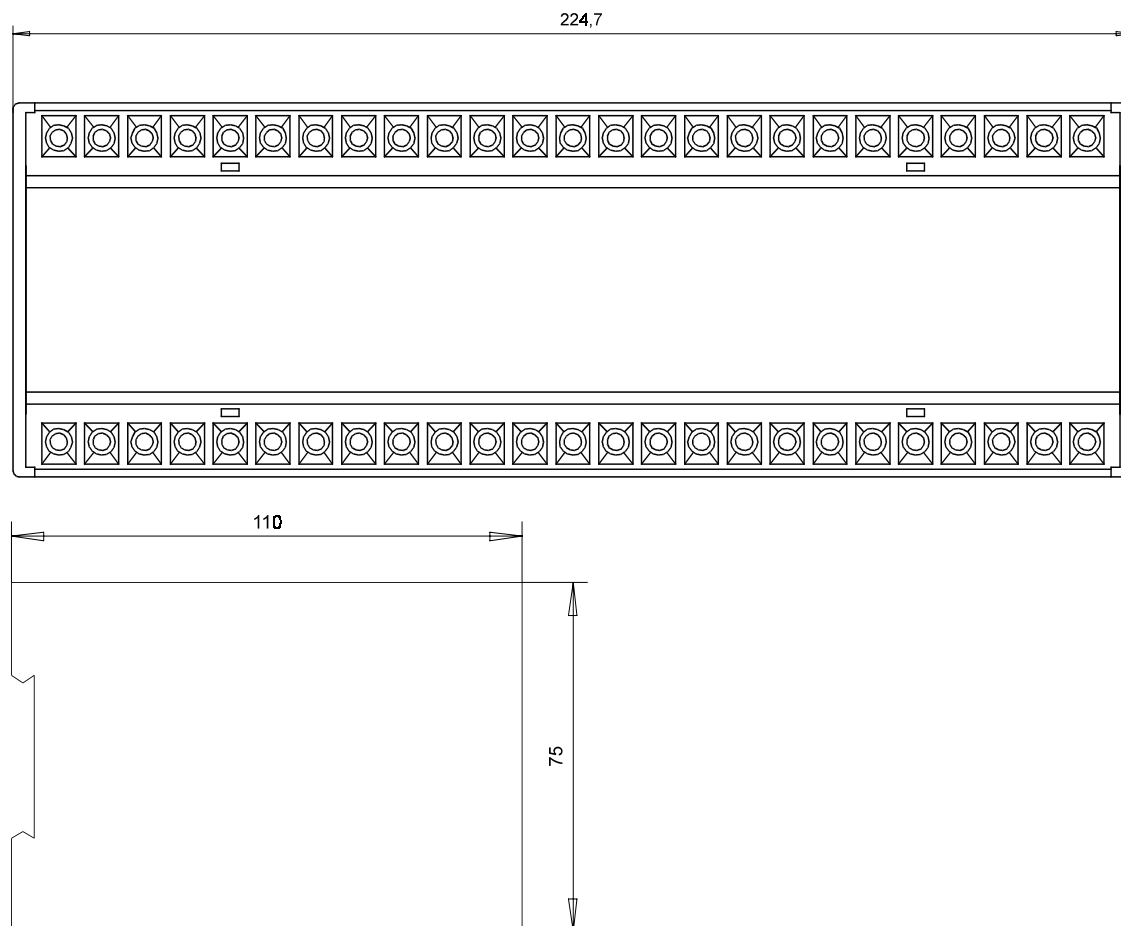

Fig. 8.1: Dimensional drawing, dimensions in mm

Connection terminals

The connection of up to a maximum $2 \times 2.5 \text{ mm}^2$ cross-section conductors is possible. For this the transparent cover of the unit has to be removed.

9 Order form

Mains decoupling relay XRW1-	2	7
Voltage, frequency and df/dt-supervision		
Rated voltage: 690 V		

Interface adapter **RSC2-485-232-1**
Interface adapter RS232 and RS485 (with galvanical decoupling)

Important: For supplying the interface adapter needed:

Plug-in power supply
for interface transformer **RSC2-NT1-230**
230 V 50/60 Hz with german safety plug

For all MR - devices that were ordered inclusive interface, the software **HTL/PL-Soft** for setting and measuring will be supplied on request without extra charge.

Setting list XRW1

Project: _____ SEG job.-no.: _____

Function group: = _____ Location: ± _____ Relay code: - _____

Relay functions: _____ Password: _____

Function		Unit	Default settings	Actual settings
Δ/Y	input transformer connection		Y	
$U<$	pickup value for undervoltage element (low set)	V	630	
$t_{U<}$	tripping delay for undervoltage element	s	0.04	
$U<<$	pickup value for undervoltage element (high set)	V	594	
$t_{U<<}$	tripping delay for undervoltage element	s	0.04	
$U>$	pickup value for overvoltage element (low set)	V	770	
$t_{U>}$	tripping delay for overvoltage element	s	0.04	
$U>>$	pickup value for overvoltage element (high set)	V	800	
$t_{U>>}$	tripping delay for overvoltage element	s	0.04	
f_N	rated frequency	Hz	50	
T	frequency measuring repetition in periods	cycles	4	
f_1	pickup value for frequency element 1	Hz	4800	
t_{f_1}	tripping delay for frequency element 1	s	0.1	
f_2	pickup value for frequency element 2	Hz	4900	
t_{f_2}	tripping delay for frequency element 2	s	0.1	
f_3	pickup value for frequency element 3	Hz	5100	
t_{f_3}	tripping delay for frequency element 3	s	0.1	
df	pickup value for rate of frequency (dt/dt) in	Hz/s	EXIT	
dt	measuring repetition for df/dt	periods	2	
$U_B<$	voltage threshold value for frequency and vector surge measuring (or df/dt)	V	40	
RS	Slave address of the serial interface		1	

Ext. blocking parameter setting

	U<	U<<	U>	U>>	f1	f2	f3	df/dt
Default setting	BLOC	BLOC	NO_B	NO_B	BLOC	BLOC	NO_B	BLOC
Actual setting								

Setting of dip switches

Dip switch	1		2		3		4	
	Default setting	Actual setting	Default setting	Actual setting	Default setting	Actual setting	Default setting	Actual setting
ON							no function	
OFF	X		X		X		X	



Schaltanlagen-Elektronik-Geräte GmbH & Co. KG
 Abteilung Gerätevertrieb / Electronic Devices Sales Department
 Krefelder Weg 47 · D - 47906 Kempen (Germany)
 Postfach 10 07 67 (P.O.B.) · D - 47884 Kempen (Germany)
 Tel.: +49 (0)21 52 1 45-1 · Fax.: +49 (0)21 52 1 45-3 54
 e-mail: electronics@avkseg.com