

## IRU1-DC - DC Voltage Relay

Woodward Governor Company reserves the right to update any portion of this publication at any time. Information provided by Woodward Governor Company is believed to be correct and reliable. However, no responsibility is assumed by Woodward Governor Company unless otherwise expressly undertaken.

© Woodward 1994-2008

## Content

<b>1.</b>	<b>Introduction .....</b>	<b>4</b>
<b>2.</b>	<b>Application .....</b>	<b>5</b>
<b>3.</b>	<b>Characteristics and features .....</b>	<b>6</b>
<b>4.</b>	<b>Design .....</b>	<b>7</b>
4.1	Connections .....	7
4.1.1	Voltage measuring inputs .....	7
4.1.2	Output relays .....	7
4.2	Front plate .....	8
4.2.1	LEDs .....	8
4.2.2	DIP-switches .....	8
4.2.3	Push-button <RESET> .....	9
4.3	Code jumper .....	9
<b>5.</b>	<b>Working Principle .....</b>	<b>11</b>
<b>6.</b>	<b>Operations and settings .....</b>	<b>12</b>
6.1	Layout of the operating elements .....	12
6.2	Setting of parameters by means of DIP-switches .....	12
6.2.1	Setting of the pickup value for overvoltage supervision $U>$ .....	12
6.2.2	Setting of the pickup value for the undervoltage supervision $U<$ .....	12
6.2.3	Setting of trip delay .....	13
6.2.4	Indication of faults .....	13
6.3	Reset .....	13
6.3.1	Reset by pressing pushbutton <RESET> .....	13
6.3.2	Automatic reset .....	13
<b>7.</b>	<b>Housing .....</b>	<b>14</b>
7.1	Individual housing .....	14
7.2	Rack mounting .....	14
7.3	Terminal connections .....	15
<b>8.</b>	<b>Relay testing and commissioning .....</b>	<b>16</b>
8.1	Power on .....	16
8.2	Checking the setting value .....	16
8.3	Secondary test .....	17
8.3.1	Test equipment .....	17
8.3.2	Example test circuit .....	17
8.3.3	Testing of pickup- and reset values .....	18
8.3.4	Trip delay test .....	18
8.4	Maintenance .....	18
<b>9.</b>	<b>Technical Data .....</b>	<b>19</b>
9.1	Measuring input .....	19
9.2	Auxiliary voltage .....	19
9.3	Common Data .....	19
9.4	Output relays .....	19
9.5	System data .....	20
9.6	Setting ranges and steps .....	21
9.7	Dimensional drawing .....	22
<b>10.</b>	<b>Order Form .....</b>	<b>23</b>

# 1. Introduction

---

When compared with traditional protection systems the protective relaying with MR- and IR-relays of our HIGH TECH LINE offers several advantages.

All MR protection relays are based on microprocessor technology. They present the generation of our most efficient protection relays, because of their capabilities to process the measuring values digitally and to perform arithmetical and logical operation. Additional advantages such as very low power consumption, adaptability, possibilities for self-supervision, flexible construction, selection of relay characteristics are completely utilized.

Some IR protection relays are based on microprocessor and some on analog technology. They present our low-priced protection relay generation and are used for all basic protection application.

The following properties of the IR protection relays, such as:

- Integration of multiple protection functions into one compact housing,
- User-friendly setting procedure by means of DIP-switches,
- Compact design due to SMD-technique,

are their superiority over the traditional protection systems.

For all applications of a more complex nature, e.g. directional earth fault detection and where operating convenience, fault analysis and communication ability are required, MR-relays are used.

All relays of the HIGH TECH LINE are available for through panel mounting and in 19" racks. Connection terminals are of plug-in type. All IEC/DIN regulations required for the individual application are reliably met by these relays.

---

## 2. Application

---

The voltage relay IRU1-DC is used for supervision of DC voltages. This relay is used e.g. for supervision of intermediate circuits, station batteries or starter batteries.

### 3. Characteristics and features

---

- Static protective device
- Voltage supervision with one stage under- and over-voltage function
- Extremely wide setting ranges and fine steps
- Separately adjustable, independent timers for U< and U>
- Independent trip delays of the individual elements
- Wide operating ranges of the supply voltage (AC/DC)
- Coding plugs for latching or auto-reset of LED indications and output relays

## 4. Design

### 4.1 Connections

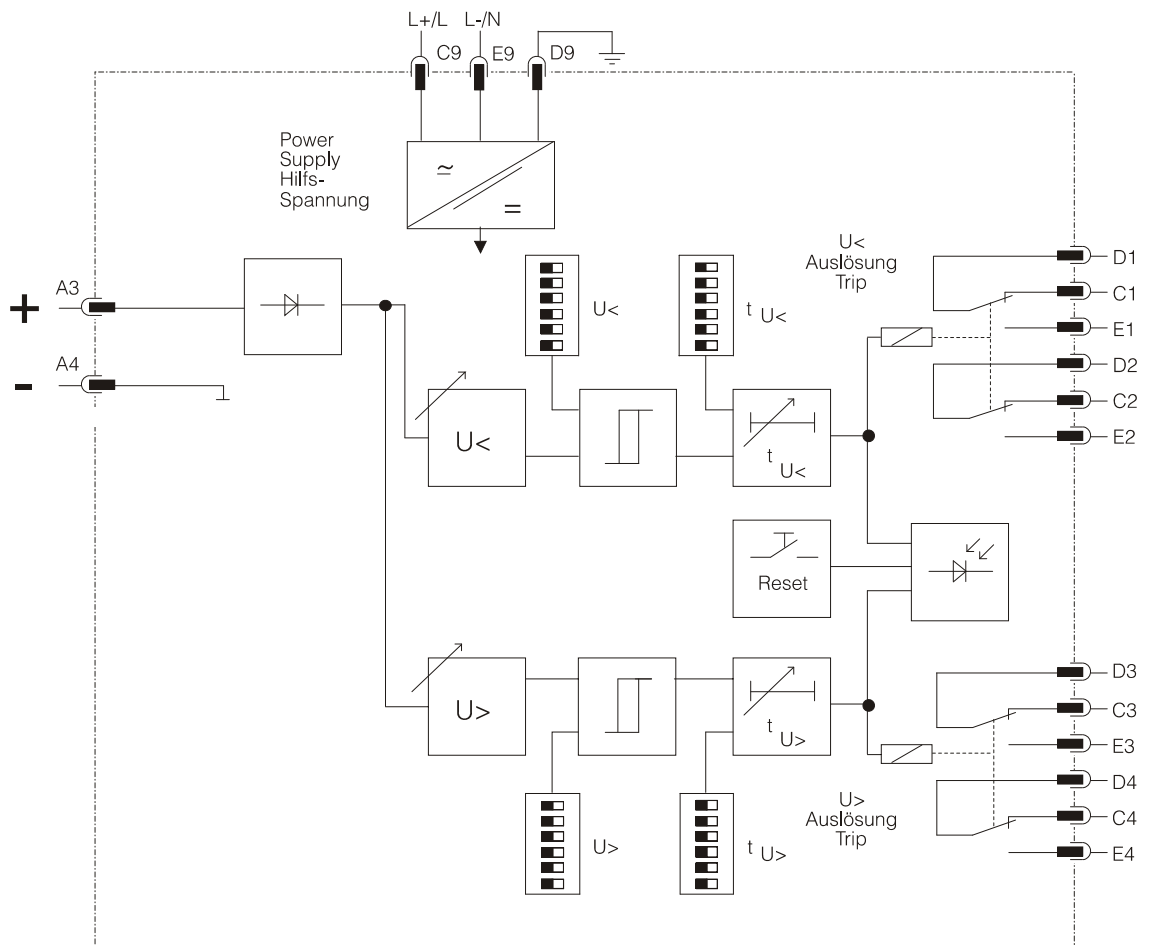

Figure 4.1: Connection diagram IRU1-DC

#### 4.1.1 Voltage measuring inputs

DC voltage is connected to the protection relay via terminals A3 and A4.

#### 4.1.2 Output relays

The IRU1-DC is equipped with one tripping relay for overvoltage and one for undervoltage supervision each with two change-over contacts:

Tripping U<: D1, C1, E1; D2, C2, E2

Tripping U>: D3, C3, E3; D4, C4, E4

## 4.2 Front plate

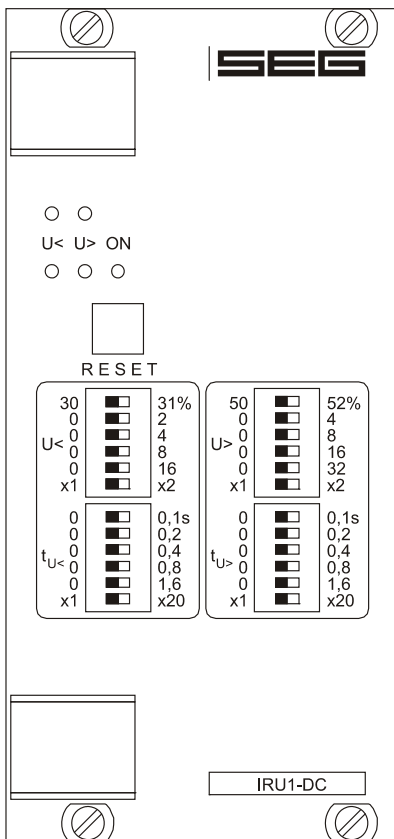

Figure 4.2: Front plate IRU1-DC

The front plate of IRU1-DC comprises the following operation- and indication elements:

- 4 DIP-switches sets of for the setting of tripping values and trip delays
- 5 LEDs for the indication of faults and the readiness for service
- 1 pushbutton <RESET>

### 4.2.1 LEDs

The IRU1-DC front plate provides five LEDs, for indication of the following operation modes:

- ready for service LED ON (green)
- undervoltage alarm  $U<$ , top LED (yellow)
- overvoltage alarm  $U>$ , top LED (yellow)
- undervoltage trip  $U<$ , bottom LED (red)
- overvoltage trip  $U>$ , bottom LED (red)

### 4.2.2 DIP-switches

The 4 sets of DIP-switches on the front plate of the IRU1-DC serve to adjust tripping values and times.



### 4.2.3 Push-button <RESET>

The pushbutton <RESET> is used to acknowledge and reset the LEDs and the tripping relay after a tripping with the appropriate pre-adjustment (see chapter 4.3). Indications and output-elements, which are coded on latching, have to be reset manually by pressing pushbutton <RESET>.

## 4.3 Code jumper

At the rear of the front plate, are four coding plugs for pre-adjustment of the LEDs' function as well as for the trip relays' function.

The function of alarm-LEDs (yellow) is not codeable. They light up as soon as threshold is exceeded and they will extinguish automatically, if the threshold falls below the setting value.

**Note:**

At delivery of the relay all coding plugs are equipped with code jumpers. The coding plugs are used for the following functions:

- coding plugs 1 + 2 undervoltage-element (U<)
- coding plugs 3 + 4 overvoltage-element (U>)

For further information please refer to chapter reset

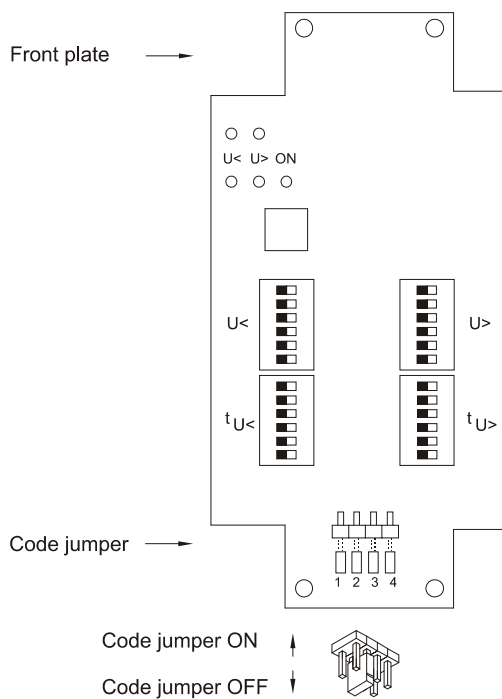

Figure 4.3: Code jumper

Code jumper	Function	Code jumper position	Operation mode
1	Undervoltage indication	OFF	Latching red LED U<
		ON	Auto-reset red LED U<
2	Undervoltage element	OFF	Latching for trip element U<
		ON	Auto-reset for trip element U<
3	Overvoltage indication	OFF	Latching red LED U>
		ON	Auto-reset red LED U>
4	Overvoltage element	OFF	Latching for trip element U>
		ON	Auto-reset for trip element U>

Table 4.1: Coding possibilities

## 5. Working Principle

---

The IRU1-DC is equipped with a one-step independent over- ( $U>$ ) and undervoltage ( $U<$ ) supervision with separately adjustable pickup values and time delays. The voltage is continuously compared with the set reference values.

**Measuring principle:**

The incoming analog voltage is subsequently filtered in order to minimize the influence of disturbing voltages. The voltage is then compared to an internal reference voltage. If the voltage value falls below or exceeds the set reference value a time circuit is activated and the appropriate output relay trips.

## 6. Operations and settings

### 6.1 Layout of the operating elements

All DIP-switches required for the setting of parameters are located on the front plate.

### 6.2 Setting of parameters by means of DIP-switches

#### 6.2.1 Setting of the pickup value for overvoltage supervision U>

With the aid of DIP-switch U> it is possible to adjust the pickup value for the U> tripping element in the range of 50 - 224% U<sub>N</sub>. The pickup value is calculated from the sum of the individual factors multiplied by the adjusted multiplication factor.

**Example:**

A tripping value of 128% U<sub>N</sub> is to be adjusted.

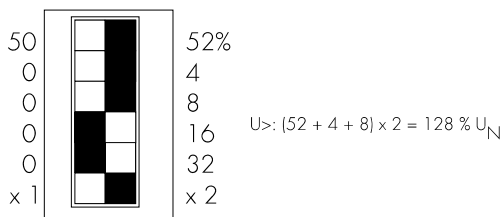

Figure 6.1: Setting example

#### 6.2.2 Setting of the pickup value for the undervoltage supervision U<

With the aid of DIP-switch U< it is possible to adjust the pickup value for the U< tripping element in the range of 30 - 122% U<sub>N</sub>. The pickup value is calculated from the sum of the individual factors multiplied by the adjusted multiplication factor.

**Example:**

A tripping value of 90% U<sub>N</sub> is to be adjusted.

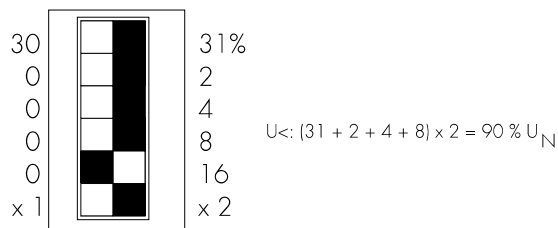

Figure 6.2: Setting example

### 6.2.3 Setting of trip delay

Each according to the unit type, the trip delay can be set with the aid of the DIP-switches  $t_{U<}$  and  $t_{U>}$  in the range of 0.1 - 62 s. The appropriate tripping value is calculated from the sum of the individual factors multiplied by the adjusted multiplication factor (1 or 20).

Example:

A trip delay of 14 s is to be adjusted.

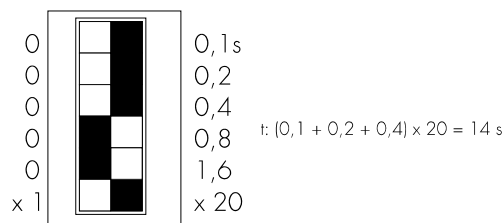

Figure 6.3: Setting example

### 6.2.4 Indication of faults

For the fault indication the IRU1-DC front plate provides two LEDs for each function:

- U>: upper LED indicates alarm (yellow), lower LED indicates trip (red)
- U<: upper LED indicates alarm (yellow), lower LED indicates trip (red).

## 6.3 Reset

### 6.3.1 Reset by pressing pushbutton <RESET>

By pressing the pushbutton <RESET> the tripping relay is reset and LED U< or U> will extinguish. For this purpose, it is necessary that all code jumpers are in position "OFF" (see also chapter 4.3).

### 6.3.2 Automatic reset

#### Code jumper 1+3

The red fault indication LEDs U</U> are coded on latching, if no code jumper is used on coding plug 1 or 3.

The fault indication can only be reset manually by actuating the pushbutton <RESET>.

The red fault indication LEDs will be reset automatically after clearance of the fault, if code jumpers are used on coding plug 1 or 3.

#### Code jumper 2+4

The tripping elements are coded on latching, if no code jumper is used on coding plug 2 or 4.

The corresponding tripping element can only be reset manually by actuating the pushbutton <RESET>.

The tripping elements will reset automatically after clearance of the fault, if code jumpers are used on coding plug 2 or 4.

## 7. Housing

---

The IRU1-DC can be supplied in an individual housing for flush-mounting or as a plug-in module for installation in a 19" mounting rack according to DIN 41494. Both versions have plug connectors. Relays of variant D are complete devices for flush mounting, whereas relays of variant A are used for 19" rack mounting. Housing variant A to be installed in switchboards of protection class IP51. For switchboards of lower protection classes housing variant D can be used.

### 7.1 Individual housing

The individual housing of the IRU1-DC is constructed for flush-mounting. The dimensions of the mounting frame correspond to the requirements of DIN 43700 (72 x 144 mm). The cut-out for panel mounting is 68 x 138 mm.

The front plate of the IRU1-DC is covered with a trans-parent, sealable flap (IP54). For case dimensions and cut-out refer to "technical data". The individual housing is fixed with the supplied clasps from the rear of the panel.

### 7.2 Rack mounting

The IRU1-DC is in general suitable for installation in a modular carrier according to DIN 41494. The installation dimensions are: 12 TE; 3 HE.

According to requirements, the IRU1-DC devices can be delivered mounted in 19" racks.

If 19" racks are used the panel requires protection class IP51. For switchboards with lower degree of protection must be used individual housing.

## 7.3 Terminal connections

The plug-in module has a very compact base with plug connectors and screwed-type connectors.

- 8 poles screw-type terminals (terminal connectors series A with a short time current capability of 500 A/1s) for voltage circuits.
- 27 poles screw-type terminals for relay outputs, supply voltage etc. (terminal connectors series C, D and E, max. 6 A current carrying capacity). Connection with tabs 6.3 x 0.8 mm for cable up to max. 1.5 mm<sup>2</sup> or with tabs 2.8 x 0.8 mm for cable up to max. 1 mm<sup>2</sup>.

By using 2.8 x 0.8 mm tabs a bridge connection between different poles is possible.

The following figure shows the terminal block of IRU1-DC:

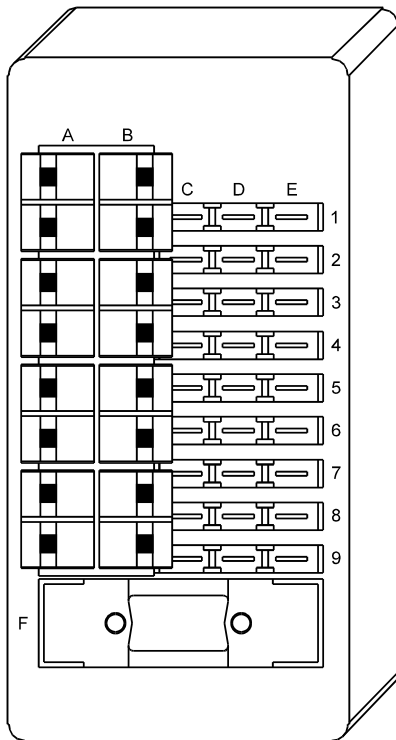

Figure 7.1: Terminal block

## 8. Relay testing and commissioning

---

The following test instructions should help to verify the protection relay performance before or during commissioning. To avoid a relay damage and to ensure a correct relay operation, be sure that:

- the auxiliary power supply rating corresponds to the auxiliary voltage on site
- the rated voltage corresponds to the plant data on site,
- the voltage transformer circuits are connected to the relay correctly
- all control- and measuring circuits as well as the out-put relays are connected correctly.

### 8.1 Power on

**Note!**

Prior to switch on the auxiliary power supply, be sure that the auxiliary supply voltage corresponds with the rated data on the type plate.

When the auxiliary power supply is switched on (terminals C9/E9) please observe that the LED "ON" is alight.

### 8.2 Checking the setting value

Due to a check of the DIP-switch positions, the actual thresholds can be established. The setting values can be corrected, if necessary by means of the DIP-switches.



## 8.3 Secondary test

### 8.3.1 Test equipment

- Voltmeter with class 1 or better,
- Auxiliary power supply with the voltage corresponding to the rated data on the type plate,
- DC voltage supply (adjustable in the range from 0 -  $2.4 \times U_N$ )
- Timer to measure the operating time
- Switching device
- Test leads and tools

### 8.3.2 Example test circuit

For testing IRU1-DC only voltage signals are used. Figure 8.1 shows an example of a test circuit with variable voltage source.

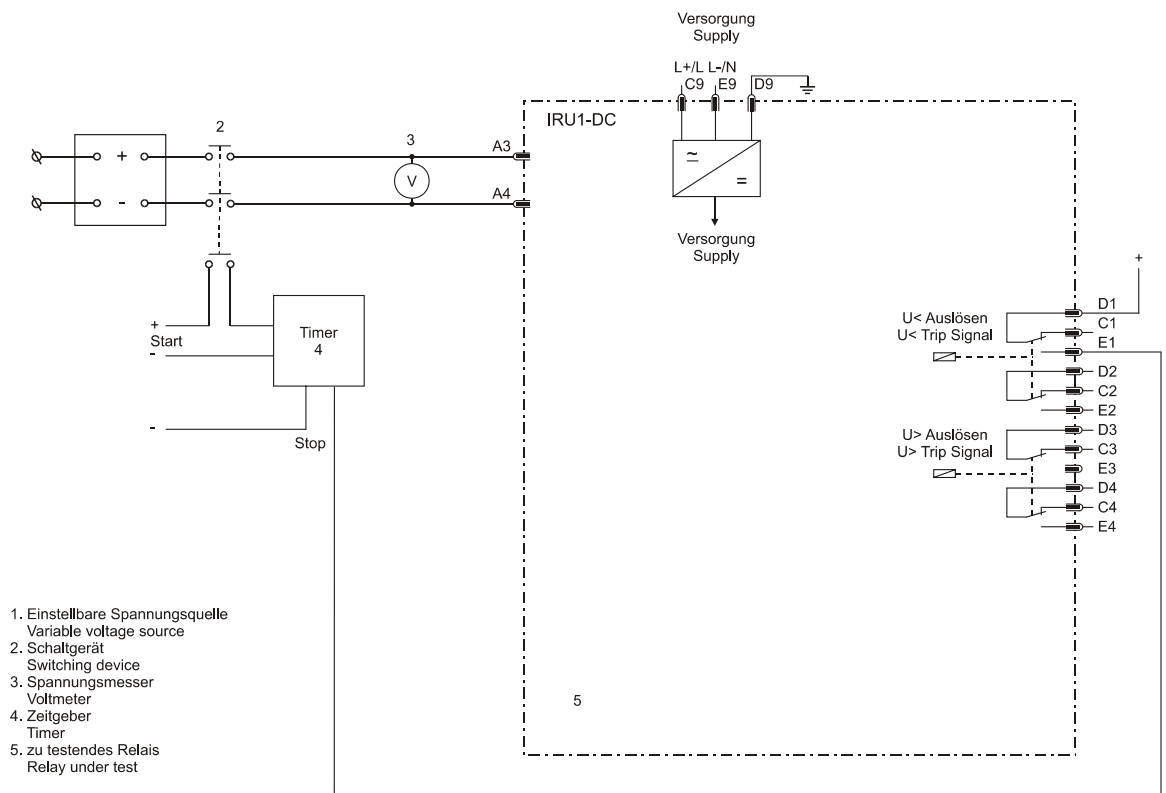

Figure 8.1: Test circuit

### 8.3.3 Testing of pickup- and reset values

For testing the pickup values of  $U>$  and  $U<$ , the test voltage (DC) has to be connected to the relay (terminals A3 / A4). When testing the overvoltage pickup value, at first the test voltage has to be lower than the set pickup value for  $U>$ . Then the test voltage has to be gradually increased until the relay picks up. This will be indicated by the upper LED  $U>$  (yellow). Reading of the voltmeter must not deviate from the pickup value  $U>$  by more than  $\pm 1\%$ .

For ascertaining the reset value of the overvoltage pickup value, the test voltage has to be slowly de-creased until the output relay  $U>$  is de-energized (on condition of appropriate encoding). Upper LED  $U<$  then extinguishes.

The reset value must not be greater than 0.97 times the pickup value i.e. the resetting ratio of the overvoltage supervision is  $< 1$ .

When testing the undervoltage pickup value, at first the test voltage has to be higher than the set pickup value for  $U<$ . Then the test voltage has to be gradually de-creased until the relay is de-activated. This will be indicated by the upper LED  $U<$  (yellow).

Reading of the voltmeter must not deviate from the pickup value  $U<$  by more than  $\pm 1\%$ .

For ascertaining the reset value of the undervoltage pickup value, the test voltage has to be slowly in-creased until the output relay  $U<$  is energized (on condition of appropriate encoding).

Upper LED  $U<$  then extinguishes.

The reset value must not be greater than 1.03 times the pickup value i.e. the resetting ratio of the undervoltage supervision is  $> 1$ .

### 8.3.4 Trip delay test

For testing the trip delay a timer has to be connected to the output relay  $U>$  or  $U<$ .

The timer has to be started at the same time as the test voltage will be switched on, and be stopped in the instant of relay trip.

When testing the trip delay of the overvoltage pickup value, the test voltage must be higher than the pickup value itself (e.g. pickup value  $+20\%$ ).

Same procedure has to be done in the similar manner for testing the trip delay of the undervoltage pickup value.

The measured trip delay must not deviate from the set trip delay by more than  $\pm 3\%$  or  $\pm 20$  ms.

## 8.4 Maintenance

Maintenance testing is generally done on site at regular intervals. These intervals vary among users depending on many factors: e.g. the type of protective relays employed; the importance of the primary equipment being protected; the users past experience with the relay, etc.

For static relays like IRU1-DC, maintenance testing will be performed at least once a year according to the experiences.

## 9. Technical Data

### 9.1 Measuring input

#### Rated data

Nominal voltage $U_N$ :	24, 60, 100, 230, 400 V DC
Power consumption in voltage circuit:	<1 VA
Thermal withstand capability in voltage circuit:	Continuously $2 \times U_N$

### 9.2 Auxiliary voltage

Rated auxiliary voltage $U_H$ :	24 V working range 16 - 60 V AC / 16 - 80 V DC 110 V working range 50 - 270 V AC / 70 - 360 V DC
Power consumption at 24 V:	at 24 V standby approx. 3 W    operating approx. 6 W at 110 V standby approx. 3 W    operating approx. 6 W

### 9.3 Common Data

Permissible interruption of the supply voltage without influence on the unit function:	50 ms
Drop-out ratio:	$U >: > 97\%$ $U <: < 103\%$
Returning time:	30 ms
Min. response time:	30 ms

### 9.4 Output relays

The output relays have the following characteristics:  
maximum breaking capacity: 250 V AC / 1500 VA / continuous current 6 A

for DC-voltage:

	ohmic	L/R = 40 ms	L/R = 70 ms
300 V DC	0,3 A / 90 W	0,2 A / 63 W	0,18 A / 54 W
250 V DC	0,4 A / 100 W	0,3 A / 70 W	0,15 A / 40 W
110 V DC	0,5 A / 55 W	0,4 A / 40 W	0,2 A / 22 W
60 V DC	0,7 A / 42 W	0,5 A / 30 W	0,3 A / 17 W
24 V DC	6 A / 144 W	4,2 A / 100 W	2,5 A / 60 W

Max. rated making current:	64 A (VDE 0435/0972 and IEC 65/VDE 0860/8.86)
mechanical life span:	$30 \times 10^6$ operating cycles
electrical life span:	$2 \times 10^5$ operating cycles at 220 V AC / 6 A
Contact material:	silver cadmium oxide (AgCdO)

## 9.5 System data

Design standard:	
Generic standard:	EN 50082-2, EN 50081-1
Product standard:	EN 60255-6, IEC 255-4, BS 142
Specified ambient service	
Storage temperature range:	- 40°C to + 85°C
Operating temperature range:	- 20°C to + 70°C
Environmental protection class F as per DIN 40040 and per DIN IEC 68 2-3:	relative humidity 95% at 40°C for 56 days
Insulation test voltage, inputs and outputs between themselves and to the relay frame as per EN 60255-6 and IEC 255-5:	2.5 kV (eff.), 50 Hz; 1 min
Impulse test voltage, inputs and outputs between themselves and to the relay frame as per EN 60255-6 and IEC 255-5:	5 kV; 1.2/50 µs; 0.5 J
High frequency interference test voltage, inputs and outputs between themselves and to the relay frame as per EN 60255-6 and IEC 255-22-1:	2.5 kV / 1MHz
Electrostatic discharge (ESD) test as per EN 61000-4-2 and IEC 255-22-1:	8 kV air discharge, 6 kV contact discharge
Electrical fast transient (Burst) test as per EN 61000-4-8 and IEC 801-4:	4 kV / 2.5 kHz, 15 ms
Power frequency magnetic field test as per ENV 50141:	electric field strength 10 V/m
Surge immunity EN 61000-4-5:	4 kV
Radio interference suppression test as per EN 55011:	limit value class B
Radio interference radiation test as per EN 55011:	limit value class B

**Mechanical tests:**

Shock: as per DIN IEC 255-21-2: class 1  
 Vibration: as per DIN IEC 255-21-1: class 1

**Degree of Protection:**

- front plate: IP54 if front cover is closed (only D-Version)  
 Weight: approx. 1.5 kg  
 Relay case material: self-extinguishing Degree of pollution:  
 2 by using housing type A  
 3 by using housing type D  
 Overvoltage class: III

**Influence quantities:**

Influence of frequency: 40 Hz < f < 70 Hz: <3% of the set value  
 Influence of temperature:  $\pm 0.1\%/K$  from  $-20^{\circ}\text{C}$  to  $+70^{\circ}\text{C}$ , ref.  $=20^{\circ}\text{C}$   
 Influence of auxiliary voltage: no influence within the tolerable range

## 9.6 Setting ranges and steps

Parameter	Setting range	Steps	Tolerances
U<	30...61% U <sub>N</sub> 60...122% U <sub>N</sub>	1% U <sub>N</sub> 2% U <sub>N</sub>	$\pm 2\%$ of rated value in the range $U \leq U_N$ $\pm 2\%$ of setting value in the range $U > U_N$
t <sub>U&lt;</sub>	0.1...3.1 s 2s...62 s	0.1...3.1 s 2...62 s	$\pm 5\%$ or $\pm 40$ ms
U>	50...112% U <sub>N</sub> 100...224% U <sub>N</sub>	2% U <sub>N</sub> 4% U <sub>N</sub>	$\pm 2\%$ of rated value in the range $U \pm U_N$ $\pm 2\%$ of setting value in the range $U > U_N$
t <sub>U&gt;</sub>	0.1...3.1 s 2s...62 s	0.1 s 2.0 s	$\pm 5\%$ or $\pm 20$ ms

## 9.7 Dimensional drawing

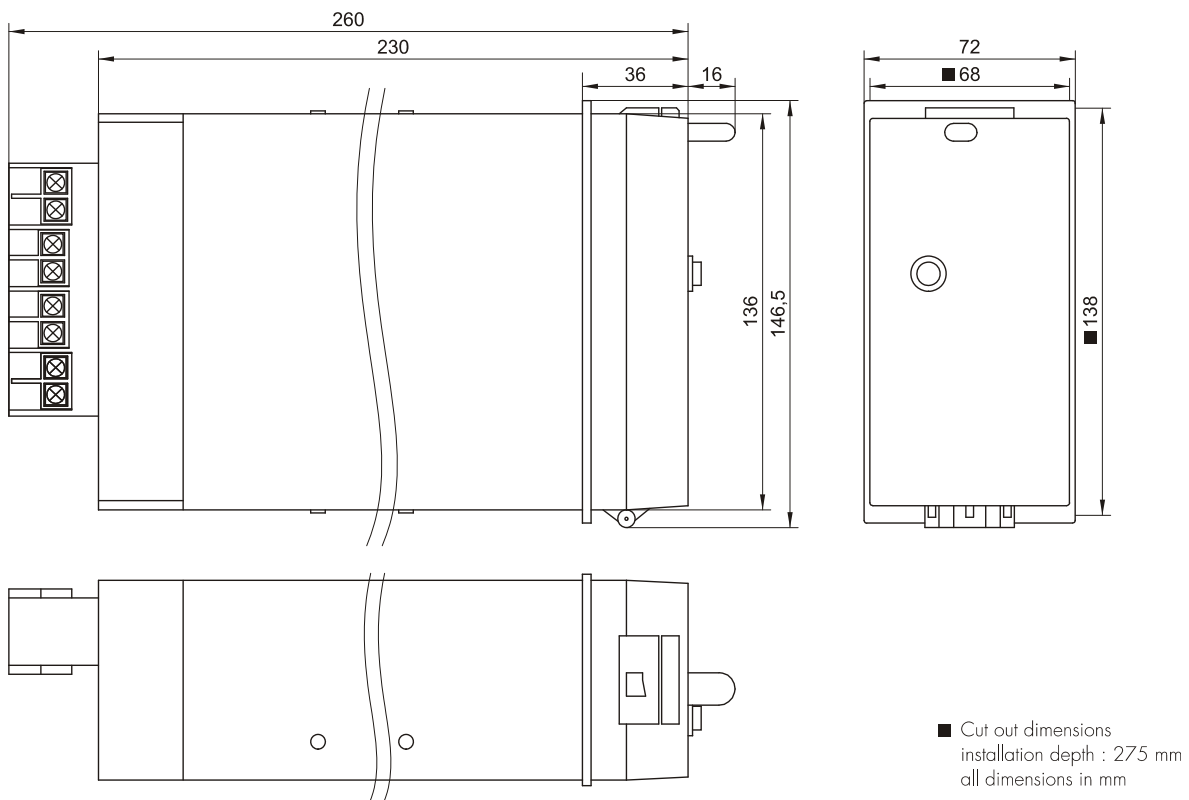

**Please observe:**

A distance of 50 mm is necessary when the units are mounted one below the other for the housing bonnet to be easily opened. The front cover can be opened downwards.

## 10. Order Form

DC voltage relay		IRU1-DC-		
Rated voltage	24 V DC		<b>24</b>	
	60 V DC		<b>60</b>	
	100 V DC		<b>100</b>	
	230 V DC		<b>230</b>	
	400 V DC		<b>400</b>	
Auxiliary voltage				
24 V (16 to 60 V AC/16 to 80 V DC)				L
110 V (50 to 270 V AC/70 to 360 V DC)				H
Housing (12TE)	19"-rack			A
	Flush mounting			D

Technical data subject to change without notice !

**Woodward Kempen GmbH**

Krefelder Weg 47 · D – 47906 Kempen (Germany)  
Postfach 10 07 55 (P.O.Box) · D – 47884 Kempen (Germany)  
Phone: +49 (0) 21 52 145 1

**Internet**

[www.woodward.com](http://www.woodward.com)

**Sales**

Phone: +49 (0) 21 52 145 216 or 342 · Telefax: +49 (0) 21 52 145 354  
e-mail: [salesEMEA\\_PGD@woodward.com](mailto:salesEMEA_PGD@woodward.com)

**Service**

Phone: +49 (0) 21 52 145 614 · Telefax: +49 (0) 21 52 145 455  
e-mail: [SupportEMEA\\_PGD@woodward.com](mailto:SupportEMEA_PGD@woodward.com)