



SPM-D2-10 Synchronizing Unit



Manual
From Release 7.10-0

Manual 37615B

**WARNING**

Read this entire manual and all other publications pertaining to the work to be performed before installing, operating, or servicing this equipment. Practice all plant and safety instructions and precautions. Failure to follow instructions can cause personal injury and/or property damage.

The engine, turbine, or other type of prime mover should be equipped with an overspeed (overtemperature, or overpressure, where applicable) shutdown device(s), that operates totally independently of the prime mover control device(s) to protect against runaway or damage to the engine, turbine, or other type of prime mover with possible personal injury or loss of life should the mechanical-hydraulic governor(s) or electric control(s), the actuator(s), fuel control(s), the driving mechanism(s), the linkage(s), or the controlled device(s) fail.

Any unauthorized modifications to or use of this equipment outside its specified mechanical, electrical, or other operating limits may cause personal injury and/or property damage, including damage to the equipment. Any such unauthorized modifications: (i) constitute "misuse" and/or "negligence" within the meaning of the product warranty thereby excluding warranty coverage for any resulting damage, and (ii) invalidate product certifications or listings.

**CAUTION**

To prevent damage to a control system that uses an alternator or battery-charging device, make sure the charging device is turned off before disconnecting the battery from the system.

Electronic controls contain static-sensitive parts. Observe the following precautions to prevent damage to these parts.

- Discharge body static before handling the control (with power to the control turned off, contact a grounded surface and maintain contact while handling the control).
- Avoid all plastic, vinyl, and Styrofoam (except antistatic versions) around printed circuit boards.
- Do not touch the components or conductors on a printed circuit board with your hands or with conductive devices.

**OUT-OF-DATE PUBLICATION**

This publication may have been revised or updated since this copy was produced. To verify that you have the latest revision, be sure to check the Woodward website.

The revision level is shown at the bottom of the front cover after the publication number. The latest version of most publications is available at:

<http://www.woodward.com/publications>

If your publication is not there, please contact your customer service representative to get the latest copy.

Important definitions**WARNING**

Indicates a potentially hazardous situation that, if not avoided, could result in death or serious injury.

**CAUTION**

Indicates a potentially hazardous situation that, if not avoided, could result in damage to equipment.

**NOTE**

Provides other helpful information that does not fall under the warning or caution categories.

Woodward reserves the right to update any portion of this publication at any time. Information provided by Woodward is believed to be correct and reliable. However, Woodward assumes no responsibility unless otherwise expressly undertaken.

© Woodward
All Rights Reserved.

Copyright And Disclaimer

Disclaimer

All information and instructions in this manual have been provided under due consideration of applicable guidelines and regulations, the current and known state of the art, as well as our many years of in-house experience. Woodward GmbH assumes no liability for damages due to:

- Failure to comply with the instructions in this manual
- Improper use / misuse
- Willful operation by non-authorized persons
- Unauthorized conversions or non-approved technical modifications
- Use of non-approved spare parts

The originator is solely liable to the full extent for damages caused by such conduct. The agreed upon obligations in the delivery contract, the general terms and conditions, the manufacturer's delivery conditions, and the statutory regulations valid at the time the contract was concluded, apply.

Copyright

This manual is protected by copyright. No part of this manual may be reproduced in any form or incorporated into any information retrieval system without written permission of Woodward GmbH.

Delivery of this manual to third parties, duplication in any form - including excerpts - as well as exploitation and/or communication of the content, are not permitted without a written declaration of release by Woodward GmbH.

Service And Warranty

Our Customer Service is available for technical information. Please see last page for the contact data.

Warranty terms

Please enquire about the terms of warranty from your nearest Woodward representative. For our contact search webpage please go to: <http://www.woodward.com/Directory.aspx>

Intended Use

The SPMD device must be used exclusively for synchronization of two electrical systems. By opening the device you will lose any warranty.

Any unauthorized modifications to or use of this equipment outside its specified mechanical, electrical, or other operating limits may cause personal injury and/or property damage, including damage to the equipment. Any such unauthorized modifications: (1) constitute "misuse" and/or "negligence" within the meaning of the product warranty thereby excluding warranty coverage for any resulting damage, and (2) invalidate product certifications or listings.

Before starting any operation and after any modification of the parameterization make a documentary proof that your programming and parameterization meets the requirements of your synchronization concept.

Typical applications for this product family/device line are for instance:

- Synchronizing a mains parallel Generator to the mains

Any usage beyond these applications the devices are not designed for. This applies also to the use as a partly completed machinery. The manufacturer cannot be held liable for any resulting damage, the user alone bears the risk for this. As to the appropriate use of the device: The technical data and tolerances specified by Woodward have to be met.

Revision History



Rev.	Date	Editor	Changes
B	2016-02-17	GG	UL rating added to technical data / ambient variables for N & XN packages. See page 59.
A	2016-01-27	GG	Changed product name from SPM-D-xxx to SPM-D2-xxx.
NEW	2015-12-09	GG	Release

Contents



Copyright And Disclaimer 3

Service And Warranty 3

Intended Use..... 3

CHAPTER 2. GENERAL INFORMATION..... 7

CHAPTER 3. ELECTROSTATIC DISCHARGE AWARENESS 8

CHAPTER 4. INSTALLATION 9

Wiring Diagrams 10

 SPM-D2-10- (Power Supply: 24 Vdc) 10

 SPM-D2-10/X (Power Supply: 24 Vdc)..... 11

 SPM-D2-10/N (Power Supply: 90 to 250 Vac or 120 to 375 Vdc) 12

 SPM-D2-10/XN (Power Supply: 90 to 250 Vac or 120 to 375 Vdc)..... 13

Reference Point 14

Power Supply 14

Measuring Inputs 15

 Generator 15

 Mains/Busbar..... 16

Discrete Inputs 17

Relay Outputs 18

Controller Outputs..... 18

 SPM-D2-10 / SPM-D2-10/N / SPM-D2-10/..... 18

 SPM-D2-10/X & SPM-D2-10/XN 19

CHAPTER 5. DESCRIPTION OF FUNCTIONS 21

Function Tables 21

 Table for Terminal 6 if Configured "Enable/Release Control" 21

 Table for Terminal 6 if Configured "OFF" 22

 Additional Conditions 23

Control Inputs..... 24

Isolation of the Power Supply from the Discrete Inputs 24

Operating Conditions 25

 No Load Control 25

 Synchronizing 25

 Synch-Check 26

 Isolated Operation 26

 Closing the CB Without Synchronization (Dead Bus Start) 26

 LED "Gen CB - ON" Flashes 26

Control Outputs..... 27

Analog Controller Outputs..... 28

CHAPTER 6. DISPLAY AND OPERATING ELEMENTS	31
Brief Explanation of the LEDs and Push Buttons	32
LEDs	32
Buttons	32
Others	32
LEDs	33
Push Buttons	35
LC Display	36
Display Monitoring in Automatic Mode: Double Voltage / Frequency Display	36
Display Monitoring in Automatic Mode: Alarm Indication	36
CHAPTER 7. CONFIGURATION.....	37
Configure Basic Data	38
Password Protection	39
Configure Basic Settings	41
Configure Controller	42
No Load Control	42
Frequency Controller	43
Voltage Controller	47
Synchronization	51
Configure Synchronization	51
Synchronization Time Monitoring	53
Dead Bus Start	54
Password Configuration	55
CHAPTER 8. COMMISSIONING.....	56
APPENDIX A. DIMENSIONS	58
APPENDIX B. TECHNICAL DATA.....	59
APPENDIX C. LIST OF PARAMETERS	61
APPENDIX D. SERVICE OPTIONS.....	63
Product Service Options.....	63
Returning Equipment for Repair.....	63
Packing a Control.....	64
Return Authorization Number RAN	64
Replacement Parts.....	64
How to Contact Woodward	65
Engineering Services	66
Technical Assistance	67

Illustrations and Tables

Illustrations

Figure 4-1: Wiring diagram SPM-D2-10.....	10
Figure 4-2: Wiring diagram SPM-D2-10/X.....	11
Figure 4-3: Wiring diagram SPM-D2-10/N.....	12
Figure 4-4: Wiring diagram SPM-D2-10/XN.....	13
Figure 4-5: Reference point.....	14
Figure 4-6: Power supply (24 Vdc).....	14
Figure 4-7: Power supply (90 to 250 Vac and 120 to 375 Vdc, N & XN Packages).....	14
Figure 4-8: Measuring inputs - generator (variable system) voltage.....	15
Figure 4-9: Measuring inputs - synchronization voltage.....	16
Figure 4-10: Discrete inputs.....	17
Figure 4-11: Relay outputs - control output #1 (CB control).....	18
Figure 4-12: Relay outputs - control output #2 (messages).....	18
Figure 4-13: Controller - SPM-D2-10 - three-position controller.....	18
Figure 4-14: Controller - SPM-D2-10/X & XN - three-position controller.....	19
Figure 4-15: Controller - SPM-D2-10/X & XN - analog controller output - speed/frequency.....	20
Figure 4-16: Controller - SPM-D2-10/X & XN - analog controller output - voltage.....	20
Figure 5-1: Control loop.....	28
Figure 5-2: Step response (example).....	28
Figure 5-3: Step response - controller set-up.....	30
Figure 6-1: Front foil.....	31
Figure 8-1: Dimensions.....	58

Tables

Table 4-1: Conversion chart - wire size.....	9
Table 5-1: Operating conditions - terminal 6 = "Enable/Release control".....	21
Table 5-2: Operating conditions - terminal 6 = "OFF".....	22
Table 5-3: Operating conditions - terms.....	23

Chapter 2. General Information

The SPM-D2-2-10 is a synchronizing unit. The following functions can be realized by using the appropriate discrete inputs:

- Synchronization
- Synch-check
- Dead bus start

The SPM-D2 starts as a standard unit that may have additional functions added with each package. The model of the SPM-D2 is designated as follows:

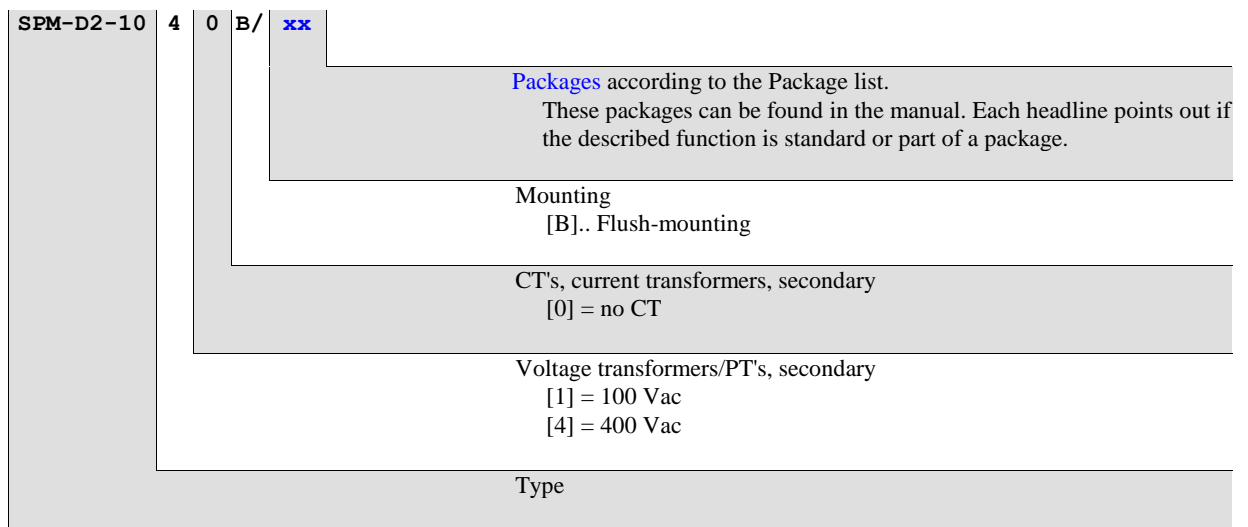

Examples:

- SPM-D2-1040B (standard unit with 400 Vac PT measuring inputs, no CT inputs, flush mounted, 24 Vdc power supply)
- SPM-D2-1010B/N (standard unit with 100 Vac measuring inputs, no CT inputs, flush mounted, 90 to 250 Vac / 120 to 375 Vdc power supply)

Intended Use The unit must only be operated as described in this manual. The prerequisite for a proper and safe operation of the product is correct transportation, storage, and installation as well as careful operation and maintenance.



NOTE

This manual has been developed for a unit equipped with all available options. Inputs/outputs, functions, configuration screens and other details described, which do not exist on your unit, may be ignored.

The present manual has been prepared to enable the installation and commissioning of the unit. Because of the large variety of parameter settings, it is not possible to cover every possible combination. The manual is therefore only a guide. In case of incorrect entries or a total loss of functions, the default settings can be taken from the enclosed list of parameters at the rear of this manual.

Chapter 3.

Electrostatic Discharge Awareness

All electronic equipment is static-sensitive, some components more than others. To protect these components from static damage, you must take special precautions to minimize or eliminate electrostatic discharges.

Follow these precautions when working with or near the control.

1. Before doing maintenance on the electronic control, discharge the static electricity on your body to ground by touching and holding a grounded metal object (pipes, cabinets, equipment, etc.).
2. Avoid the build-up of static electricity on your body by not wearing clothing made of synthetic materials. Wear cotton or cotton-blend materials as much as possible because these do not store static electric charges as much as synthetics.
3. Keep plastic, vinyl, and Styrofoam materials (such as plastic or Styrofoam cups, cup holders, cigarette packages, cellophane wrappers, vinyl books or folders, plastic bottles, and plastic ash trays) away from the control, the modules, and the work area as much as possible.
4. **Opening the Control unit will void the warranty!**
Do not remove the printed circuit board (PCB) from the control cabinet unless necessary. If you must remove the PCB from the control cabinet, follow these precautions:
 - Make sure that the unit is completely de-energized (all connectors have to be disconnected).
 - Do not touch any part of the PCB except the edges.
 - Do not touch the electrical conductors, connectors, or components with conductive devices or with bare hands.
 - When replacing a PCB, keep the new PCB in the plastic antistatic protective bag it comes in until you are ready to install it. Immediately after removing the old PCB from the control unit, place it in the antistatic protective bag.



WARNING

To prevent damage to electronic components caused by improper handling, read and observe the precautions in Woodward manual 82715, *Guide for Handling and Protection of Electronic Controls, Printed Circuit Boards, and Modules*.

Chapter 4. Installation



CAUTION

A circuit breaker must be provided near to the unit and in a position easily accessible to the operator. This must also bear a sign identifying it as an isolating switch for the unit.



NOTE

Connected inductive devices (such as operating current coils, undervoltage tripping units, or auxiliary or power contacts) must be connected to a suitable interference suppressor.



WARNING

All technical data and ratings indicated in this chapter are not definite! Only the values indicated in Appendix B: Technical Data on page 59 are valid!

The following chart may be used to convert square millimeters [mm²] to AWG and vice versa:

AWG	mm ²	AWG	mm ²	AWG	mm ²	AWG	mm ²	AWG	mm ²	AWG	mm ²
30	0.05	21	0.38	14	2.5	4	25	3/0	95	600MCM	300
28	0.08	20	0.5	12	4	2	35	4/0	120	750MCM	400
26	0.14	18	0.75	10	6	1	50	300MCM	150	1000MCM	500
24	0.25	17	1.0	8	10	1/0	55	350MCM	185		
22	0.34	16	1.5	6	16	2/0	70	500MCM	240		

Table 4-1: Conversion chart - wire size

Wiring Diagrams



SPM-D2-10- (Power Supply: 24 Vdc)

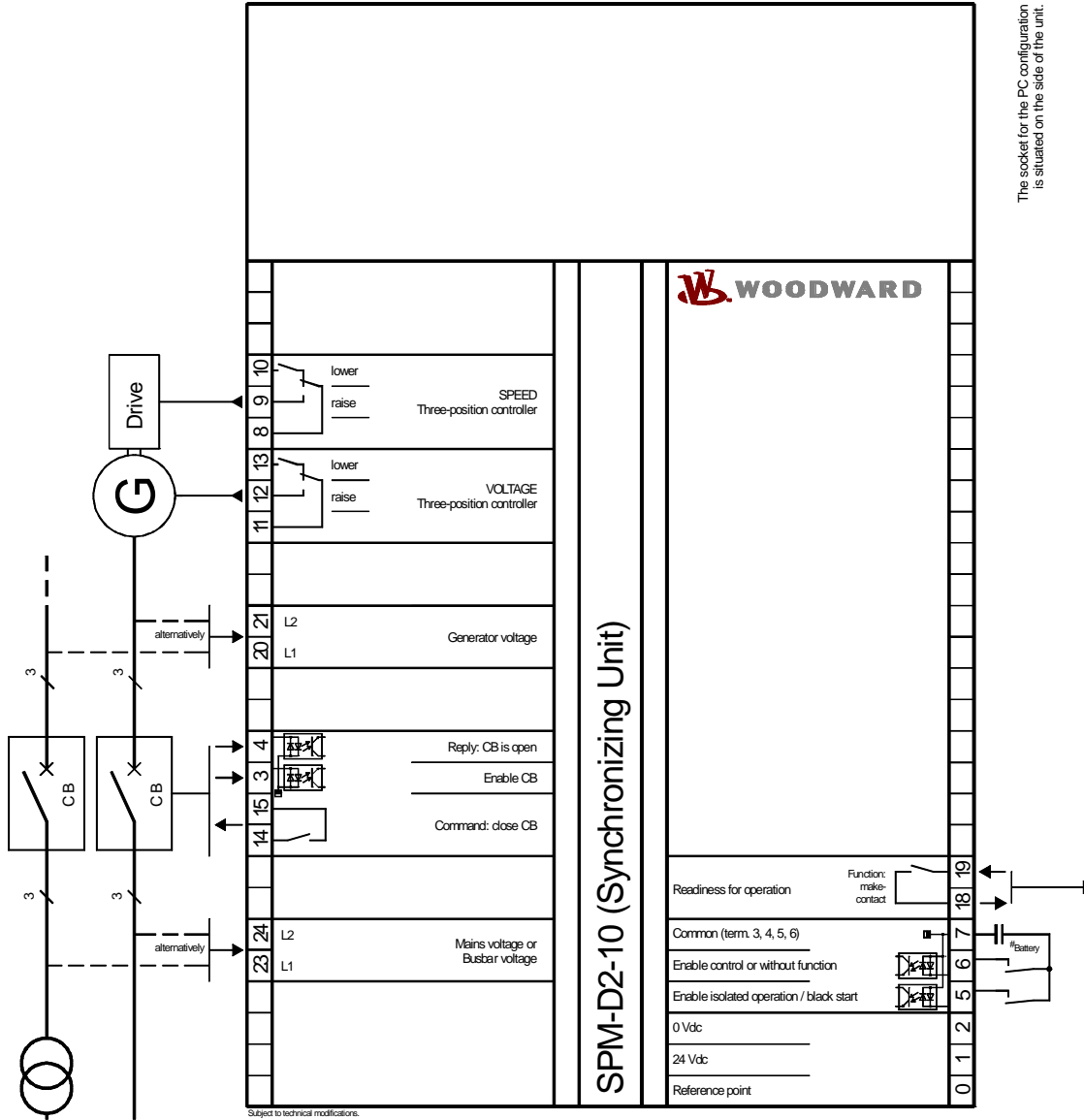

Figure 4-1: Wiring diagram SPM-D2-10

SPM-D2-10/X (Power Supply: 24 Vdc)

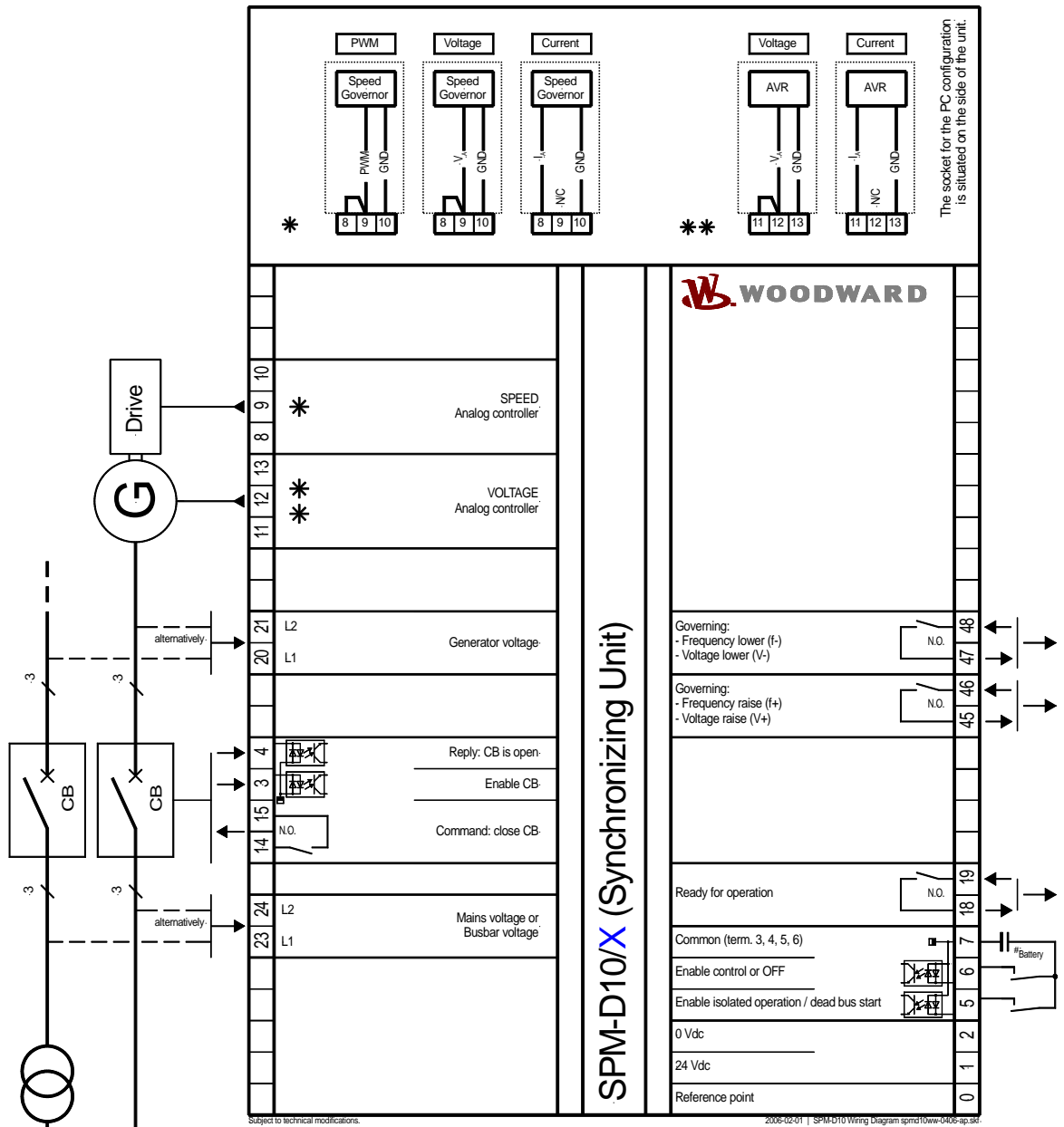

Figure 4-2: Wiring diagram SPM-D2-10/X

SPM-D2-10/N (Power Supply: 90 to 250 Vac or 120 to 375 Vdc)

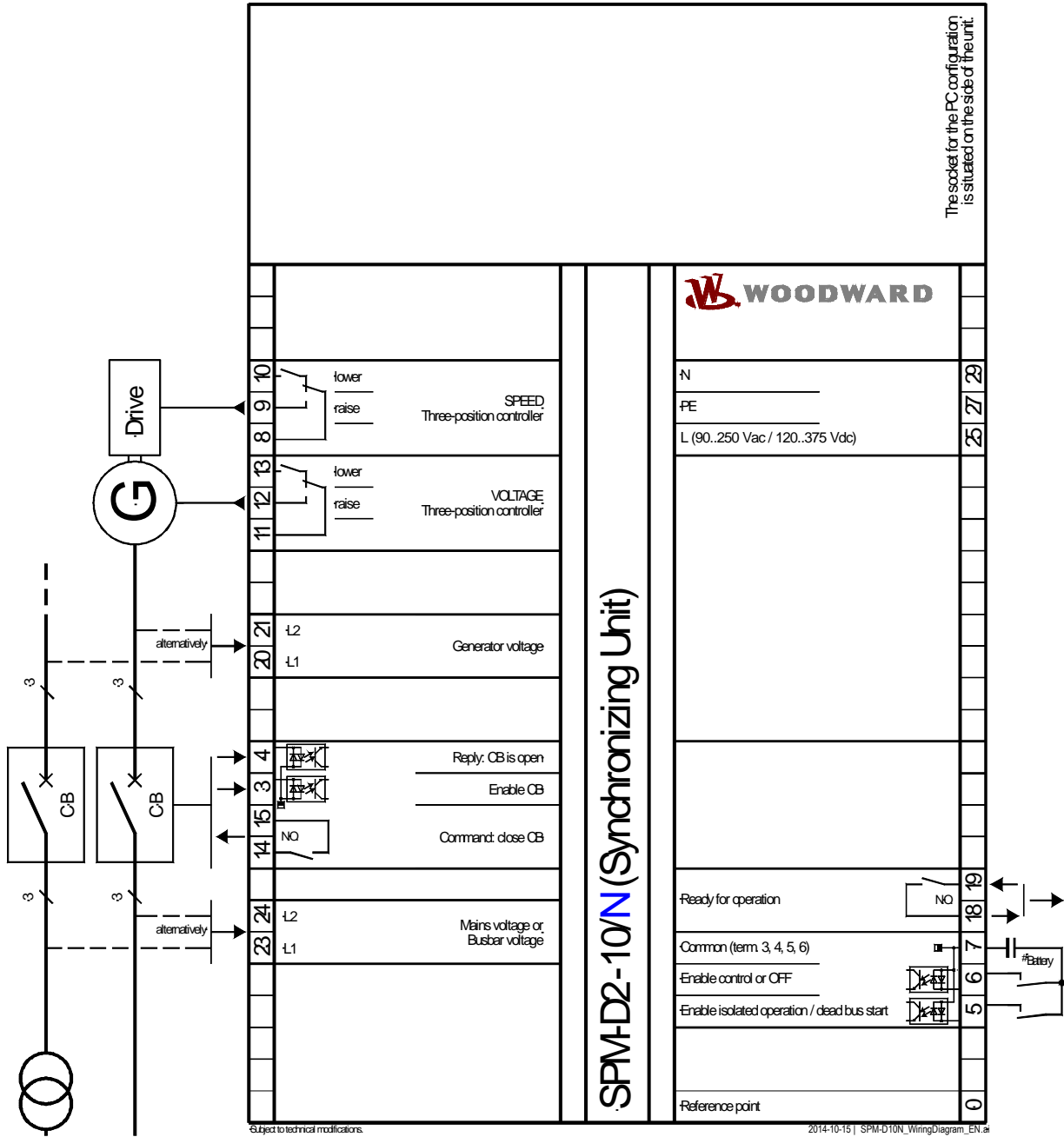

Figure 4-3: Wiring diagram SPM-D2-10/N

SPM-D2-10/XN (Power Supply: 90 to 250 Vac or 120 to 375 Vdc)

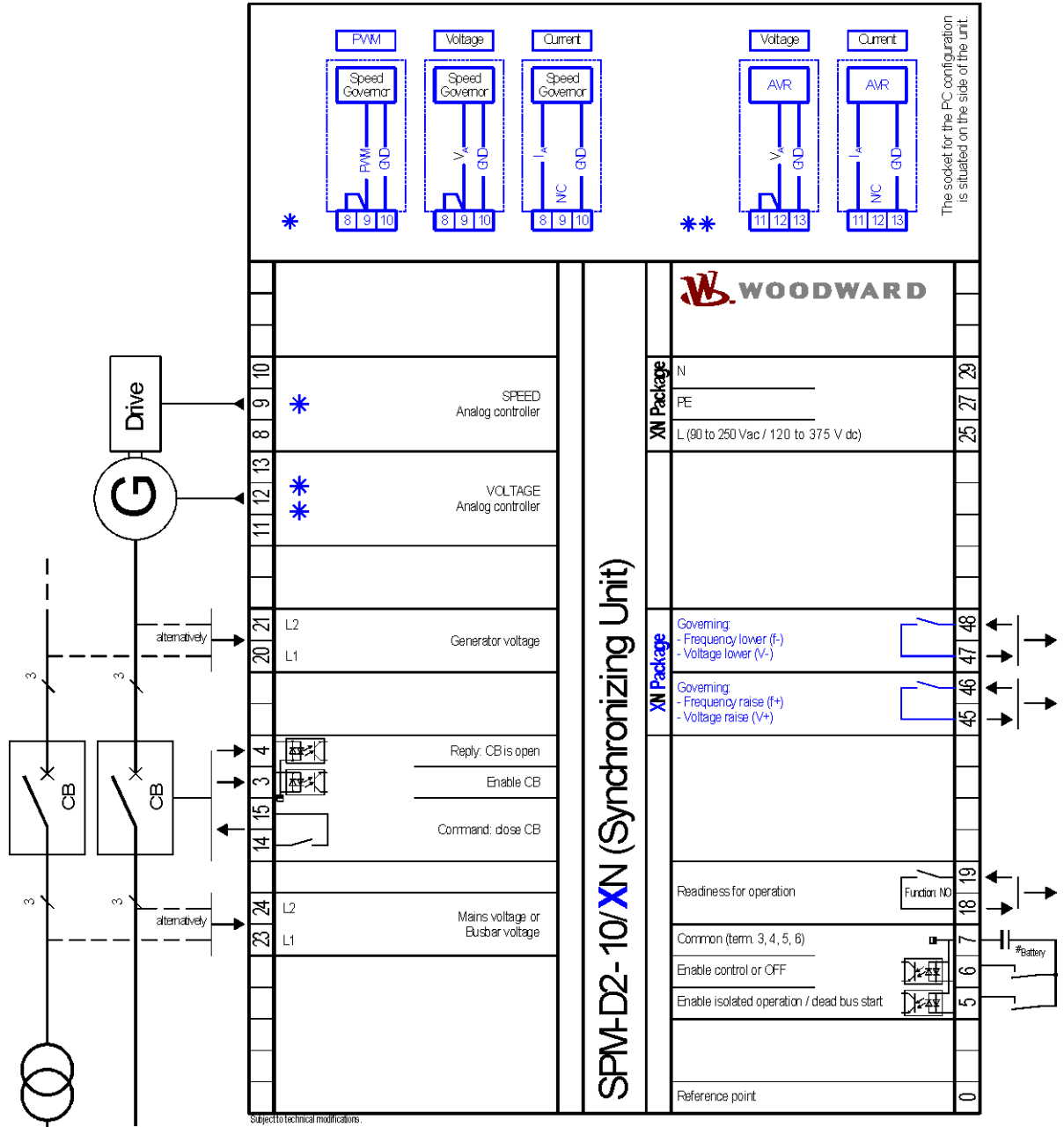

Figure 4-4: Wiring diagram SPM-D2-10/XN

Reference Point

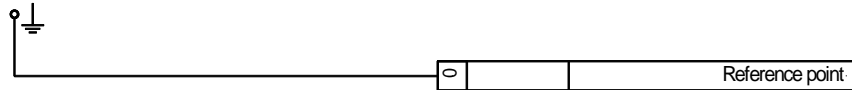

Figure 4-5: Reference point

Terminal	Description	A _{max}
0	Reference point: Neutral point of the three-phase system (3Ph4W) or neutral terminal of the voltage transformer (Measuring reference point); → with three-conductor systems (3Ph3W), do not connect	Sold.lug

Power Supply

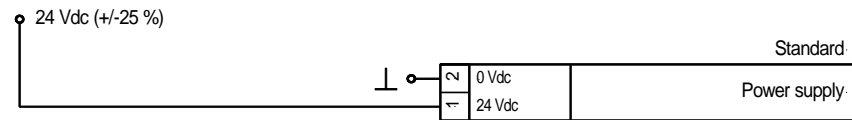

Figure 4-6: Power supply (24 Vdc)

Terminal	Description	A _{max}
Standard		
1	+24 Vdc, 10 W	2.5 mm ²
2	0 V reference potential	2.5 mm ²

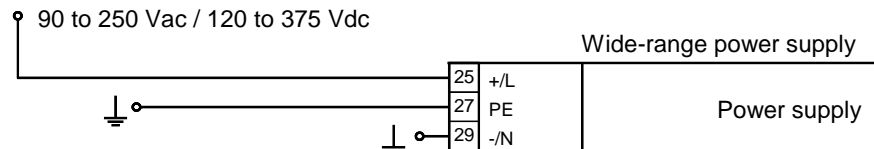

Figure 4-7: Power supply (90 to 250 Vac and 120 to 375 Vdc, N & XN Packages)

Terminal	Description	A _{max}
N & XN Packages - wide range power supply		
25	90 to 250 Vac / 120 to 375 Vdc, max. 10 W	2.5 mm ²
27	PE	2.5 mm ²
29	0 Vac	2.5 mm ²

Measuring Inputs



NOTE

The SPM-D2-10 can only operate one circuit breaker. This limits the controller to operating one synchronization point. The voltage measured by terminals 23/24 is the synchronization reference voltage for the generator (variable system) voltage measured by terminals 20/21. The synchronization reference voltage can be the mains or busbar voltage.

The mains voltage (measured via terminals 50/51/52) is used for monitoring over-/undervoltage and over-/underfrequency as well as phase/vector shift.



NOTE

There are three variations for connection to the generator (variable system) voltage:

- ① Direct connection to the low voltage system
- ② Connection to medium voltage via two-pole isolated transformer (e.g. Connection to a 3Ph3W system)
- ③ Connection to medium voltage via single-pole isolated transformer (e.g. Connection to a 3Ph4W system).

Generator

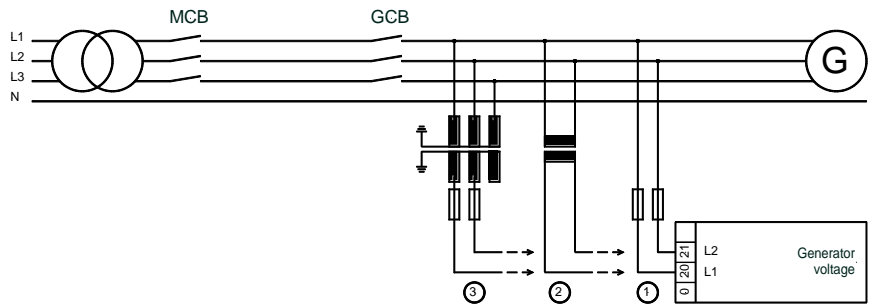

Figure 4-8: Measuring inputs - generator (variable system) voltage



NOTE

Connection corresponding to the mains configuration (see wiring diagram).

Terminal	Measurement	Description	A _{max}
Connection to the measuring circuit voltage corresponding to the variant ①, ② or ③			
20	direct or Transformer ./100 V	Generator voltage L1	2.5 mm ²
21		Generator voltage L2	2.5 mm ²
0		Reference point: N-terminal of the low voltage system or star point of the voltage transducer (measuring reference point); → do not connect in three wire (3Ph3W) installations	Sold.lug

Mains/Busbar

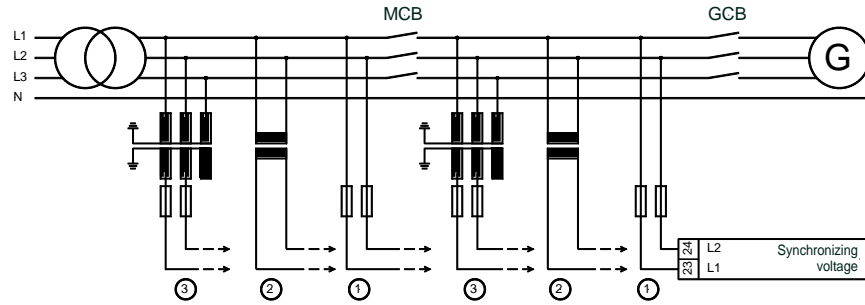

Figure 4-9: Measuring inputs - synchronization voltage



NOTE

Connection corresponding to the mains configuration (see wiring diagram).

Terminal	Measurement	Description	A _{max}
Connection to the measuring circuit voltage corresponding to variant ①, ② or ③			
23	direct	Synchronization voltage L1	2.5 mm ²
24	or ./100 V	Synchronization voltage L2	2.5 mm ²

Discrete Inputs



CAUTION

Please note that the maximum voltages which may be applied at the discrete inputs are defined as follows. Voltages higher than those specified will damage the hardware!

- Maximum input range: +/-18 to 250 Vac.

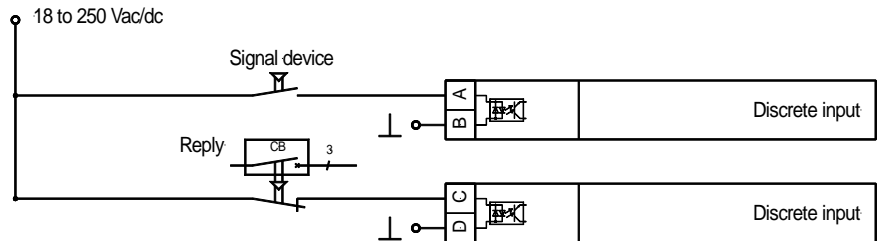

Figure 4-10: Discrete inputs

Input terminal	Common terminal	Description (acc. DIN 40 719 part 3, 5.8.3)	A _{max}
Normally open contact			
<i>A</i>	<i>B</i>		
3	7	Enable CB	2.5 mm ²
5		Enable isolated operation / dead bus start	2.5 mm ²
6		Enable control or OFF *	2.5 mm ²
Normally closed contact			
<i>C</i>	<i>D</i>		
4	7	Reply: CB is open	2.5 mm ²

* refer to Parameter "Terminal 6" on page 42

Relay Outputs

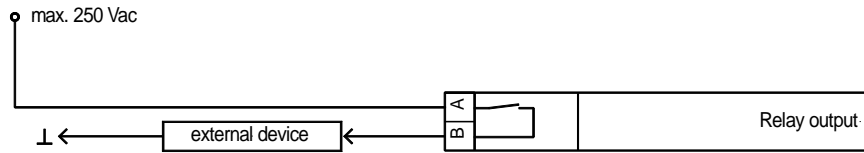

Figure 4-11: Relay outputs - control output #1 (CB control)

Root A	Switched B	Description	A _{max}
NO (make contact)			
14	15	Synchronizing pulse, Command: close CB	2.5 mm ²

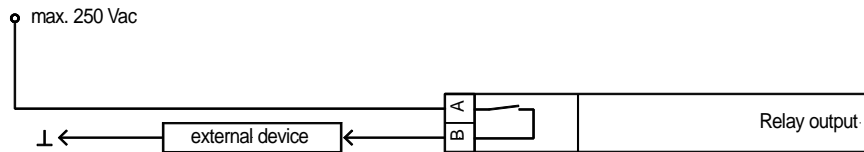

Figure 4-12: Relay outputs - control output #2 (messages)

Root A	Switched B	Description Note: The relays change state when the described function is met.	A _{max}
NO (make contact)			
18	19	Ready for operation	2.5 mm ²
NC (break contact)			

Controller Outputs



The SPM-D2-10 is equipped with two three-position controllers (made of a form C and form A relay) for raising and lowering voltage and frequency. The SPM-D2-10/X & SPM-D2-10/XN controllers can be configured for different output signals. The terminal connects differ dependent upon the signal selected.

SPM-D2-10 / SPM-D2-10/N / SPM-D2-10/

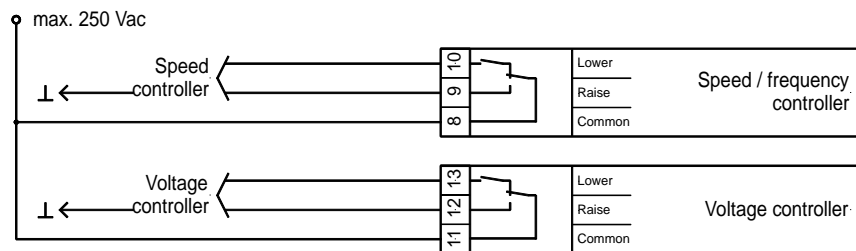

Figure 4-13: Controller - SPM-D2-10 - three-position controller

Terminal	Description	A _{max}
8	common	2.5 mm ²
9	raise	2.5 mm ²
10	lower	2.5 mm ²
11	common	2.5 mm ²
12	raise	2.5 mm ²
13	lower	2.5 mm ²

SPM-D2-10/X & SPM-D2-10/XN

The SPM-D2-10/X & SPM-D2-10/XN controller outputs can be configured for the following signals and may require the use of an external jumper between terminals.

Versions



NOTE

Only one controller output may be configured as three-step controller.

- **Three-step controller** via relay manager
 - Control of n/f: Parameter "**f control type**" = THREESTEP
 - n+/f+ = Relay connected to terminals 45/46
 - n-/f- = Relay connected to terminals 47/48
 - Control of V: parameter "**v control type**" = THREESTEP
 - V+ = Relay connected to terminals 45/46
 - V- = Relay connected to terminals 47/48

- **Analog controller output**
 - Control of n/f: Parameter "**f control type**" = ANALOG
 - Current output (mA) = no external bridge/jumper necessary
 - Voltage output (V) = external bridge/jumper between 8/9
 - Connect the Controller to terminals 9/10
 - Control of V: Parameter "**v control type**" = ANALOG
 - Current output (mA) = no external bridge/jumper necessary
 - Voltage output (V) = external bridge/jumper between 11/12
 - Connect the controller to terminals 12/13

- **PWM controller output**
 - Control of n/f: Parameter "**f control type**" = PWM
 - PWM output = external bridge/jumper between 8/9
 - Connect the controller to terminals 9/10

Connection of the controllers

Setting: 'THREESTEP' (three-position controller)

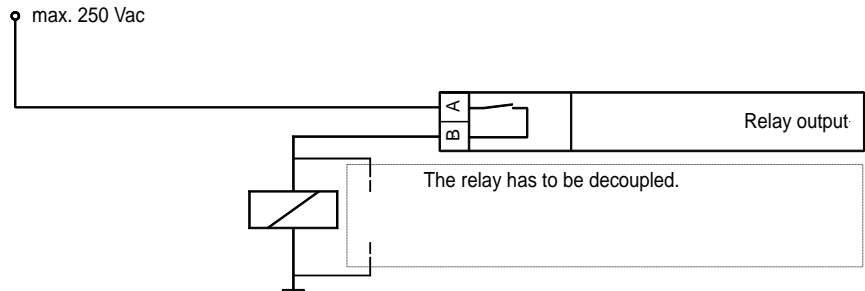

Figure 4-14: Controller - SPM-D2-10/X & XN - three-position controller

Terminal	Description	A _{max}
45	raise	2.5 mm ²
46		2.5 mm ²
47	lower	2.5 mm ²
48		2.5 mm ²

Setting: 'ANALOG' and 'PWM' (analog controller) - Frequency controller

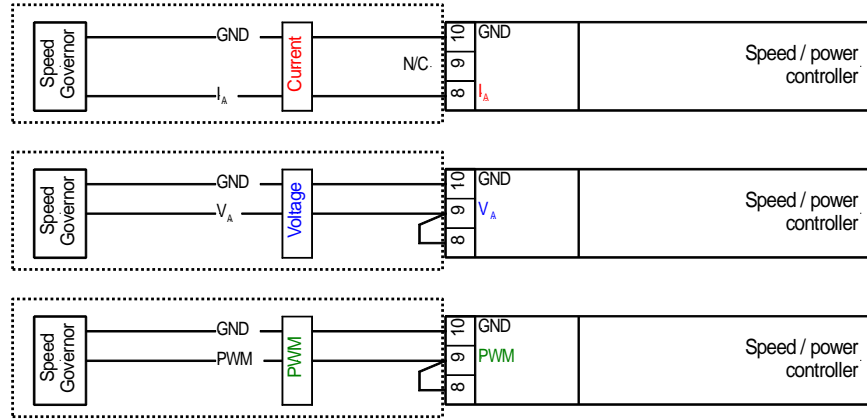

Figure 4-15: Controller - SPM-D2-10/X & XN - analog controller output - speed/frequency

Type	Terminal	Description	A _{max}
I Current	8	Speed controller / Frequency controller	2,5 mm ²
	9		2,5 mm ²
	10		2,5 mm ²
V Voltage	8	Speed controller / Frequency controller	2,5 mm ²
	9		2,5 mm ²
	10		2,5 mm ²
PWM	8	Speed controller / Frequency controller	2,5 mm ²
	9		2,5 mm ²
	10		2,5 mm ²

Setting: 'ANALOG' (analog controller) - Voltage controller

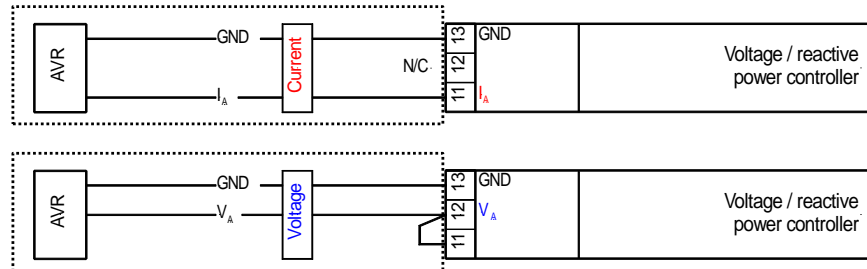

Figure 4-16: Controller - SPM-D2-10/X & XN - analog controller output - voltage

Type	Terminal	Description	A _{max}
I Current	11	Voltage controller	2.5 mm ²
	12		2.5 mm ²
	13		2.5 mm ²
V Voltage	11	Voltage controller	2.5 mm ²
	12		2.5 mm ²
	13		2.5 mm ²

Chapter 5. Description of Functions

Function Tables



Table for Terminal 6 if Configured "Enable/Release Control"

The unit may be used as an SPM-A by energizing terminal 6.

The status of the discrete inputs "Reply: CB is open" (terminal 4) and "Enable CB" (terminal 3) are displayed on the face of the controller via the LEDs "Gen CB - ON" and "Gen CB free" respectively. In addition to the state of the discrete input signals, the conditions in Table 5-3: Operating conditions - terms will affect the controller as follows:

Input signal				Operating condition	Cond.	Relay "Command: close CB" (terminals 14/15)	Operating mode SPM-A
LED "Gen-CB ON"	LED "Gen CB free"	Discr. inp term. 5: "Enable Isolated operation/dead bus start"	Discr. inp. term. 6 "Enable controller"				
0	0	x	0	Off or automatic no-load control	- C1	OFF OFF	OFF
0	0	x	1	No-load operation or synchronization	C A	OFF OFF	CHECK
0	1	0	0	OFF	A	Slip or phase match	PERMISSIVE
0	1	0	1	No-load operation or synchronization	C A	OFF Slip or phase match	RUN
0	1	1	0	OFF	A	Synchro-Check	-
0	1	1	1	No-load operation or synchronization or dead bus start	C A B	- Slip or phase match or dead bus start	RUN (extended)
1	x	0	x	OFF	-	OFF	-
1	x	1	0	OFF	-	OFF	-
1	x	1	1	Isolated operation	D	OFF	-

0: "OFF" / 1: "ON" / x: Signal of no significance (0 or 1)

Table 5-1: Operating conditions - terminal 6 = "Enable/Release control"

Table for Terminal 6 if Configured "OFF"

The SPM-D2-10 and 10/X may be used as an ASG 410+ by de-energizing terminal 6.

The status of the discrete inputs "Reply: CB open" (terminal 4) and "Enable CB" (terminal 3) is displayed on the face of the controller via the LEDs "GCB closed" and "Enable GCB" respectively. In addition to the state of the discrete input signals, the conditions in Table 5-3: Operating conditions - terms will affect the controller as follows:

Input signal			Operating condition	Cond. Refer to Table 5-3	Relay "Command: close CB" (terminals 14/15)
LED "Gen-CB ON"	LED "Gen CB free"	Discr. inp. term. 5: "Enable isolated op. / dead bus start"			
0	0	x	OFF or automatic no-load control	- C1	OFF OFF
0	1	0	No-load operation or synchronization	C A	OFF Slip or phase match
0	1	1	No-load operation or synchronization or dead bus start	C A B	OFF Slip or phase match dead bus start
1	x	0	OFF	-	OFF
1	x	1	Isolated operation	D	OFF

0: "OFF" / 1: "ON" / x: Signal of no significance (0 or 1)

Table 5-2: Operating conditions - terminal 6 = "OFF"

Additional Conditions

The functions described above for terminal 6 are dependent upon the conditions listed in Table 4-3 in conjunction with the states of the discrete inputs. The desired function must also be enabled when configuring the control unit.

Condition		
A	Synchronization Generator circuit breaker	- Generator and synchronization reference voltage must meet the following conditions: 50 % < V < 125 % of the rated voltage V_N 80 % < f < 110 % of the rated frequency f_N (if time monitoring expires, the synchronization will be aborted)
B	Dead bus start Generator circuit breaker	- Parameter "Dead bus start GCB" is configured "ON" - Synchronization reference voltage must be less than 5% of the rated voltage - Generator voltage and frequency must be within the configured limits of the dead bus start
C1	Automatic no-load control	- Parameter "Automatic no-load control" is configured "ON" - The voltage controller applies to the following conditions: Generator voltage > 50 % of the rated voltage V_N - The frequency controller applies to the following conditions: Generator frequency > 90 % of the rated frequency f_N
C	No-load operation	- For V control: Generator voltage > 50 % of rated voltage V_N - For f control: Generator frequency > 90 % of rated frequency V_N
D	Isolated operation	- Generator voltage > 50 % of rated voltage V_N - For voltage controller: Parameter "Voltage controller in isolated operation" is configured "ON" - For frequency controller: Parameter "Frequency controller in isolated operation" is configured "ON".

Table 5-3: Operating conditions - terms

Control Inputs



- Enable/Release CB**
Terminal 3

 - Terminal 6 = "Enable/Release control"
If terminal 3 is energized, the operation of the power circuit breaker is enabled. Circuit breaker operation will be disabled when terminal 3 is de-energized. This will permit the commissioning personnel to conduct testing for proper operation of the controller without having the circuit breaker closing even if the control functions are enabled. If the power circuit breaker is closed, this input has no effect.
 - Terminal 6 = "OFF"
If terminal 3 is energized, the control functions and power circuit breaker operations are enabled simultaneously. If the power circuit breaker is closed, this input has no effect.

- Reply: CB is open**
Terminal 4

The status of the CB must be transmitted to the control unit through this input. The input must be energized if the CB is open. (The status of this input is checked for plausibility and is indicated with the LED "Gen CB - ON".)

- Enable: Isolated operation/dead bus start**
Terminal 5

Energizing terminal 5 will enable a dead bus start if the circuit breaker is open. If this input is energized and the circuit breaker is closed, the frequency and voltage controllers are enabled for isolated operation.

- Enable control**
Terminal 6

If "terminal 6 is configured for "Enable control" the frequency and voltage controllers are enabled when this input is energized. If the input is prevented from energizing, commissioning personnel may conduct testing for proper operation of the control unit without the circuit breaker closing.



CAUTION

If several generators feed one busbar, it has to be ensured with external interlocking that only one of the generators is released for dead bus start at a time. If several generators are released for dead bus start at the same time, it may happen that the generator circuit breakers close at the same time, which might cause serious damage to the generators!

Isolation of the Power Supply from the Discrete Inputs



The common reference point for the discrete inputs (terminal 7) may be electrically isolated from the supply voltage (0V, terminal 2) through proper external wiring. This permits the control to utilize more than one voltage in the control wiring. This is necessary for example if the supply voltage for the control is +24 Vdc and electrical isolation of the system control voltage (e.g. 220 Vdc or 220 Vac) must be ensured.

The control should be wired as follows:

- If the discrete inputs are to utilize the same voltage as the supply voltage:
Install a jumper between terminal 7 and terminal 2 (0 V)
- If the supply voltage and control voltage are not the same:
Terminal 2: connect to 0 V of the supply voltage
Terminal 7: connect to 0 V or N of the control voltage

Operating Conditions



No Load Control

The generator voltage and generator frequency are adjusted to the configured set point values. The generator circuit breaker is open.

Synchronizing

Slip Frequency Synchronization

The generator voltage and frequency will be adjusted to the synchronization reference voltage. The circuit breaker connection command is issued with consideration for the inherent delay of the circuit breaker. The synchronization is performed according to the following conditions (refer to the "Function Tables" starting on page 21):

- The unit is in the automatic mode (LED "Automatic" is illuminated)
- Synchronization is enabled
- The voltages and frequencies are within the specified range
- If terminal 6 = OFF, the input "Enable CB" is energized
- If terminal 6 = Enable control, the input "Enable CB" is energized to enable the connection command and the input "Enable control" is energized to enable the control functions
- The input "Reply: CB is open" is energized
- The synchronization time monitoring is not enabled or has not expired

Phase Matching Synchronization

The generator voltage will be adjusted to the amplitude of the synchronization reference voltage by the voltage controller. The frequency controller is operated in one of two possible modes:

- Frequency correction: - As long as the difference between the generator and busbar/mains frequency does not fall below the configured value "df start", the generator is adjusted to the frequency of the busbar/mains.
- Phase angle correction: - If the the difference between the generator and busbar/mains frequency is less than the value "df start", the frequency controller adjusts the phase angle of the generator so that its phase angle matches that of the busbar/mains. The phase angle is controlled until the difference between the generator and the busbar/mains frequency is greater than the value "df start" plus a hysteresis of 0.8 Hz.

The connect command for the power circuit breaker is issued under the following conditions:

- The configured limits for voltage and frequency are met.
- The phase angle between the systems is less than the maximum permissible angle for the configured time
- If terminal 6 = OFF, the input "Enable CB" is energized
- If terminal 6 = Enable control, the input "Enable CB" is energized to enable the connection command and the input "Enable control" is energized to enable the control functions
- The input "Reply: CB is open" is energized

The connection is performed without consideration of the circuit breaker inherent delay. In the phase matching mode the analog input should be configured for the frequency controller.

Synch-Check

The controller can be utilized as a Synch-check module. Control functions are not performed. The "CB close" relay remains energized as long as the following conditions are met:

- The voltage differential is within the configured limit (screen "synchronization dV_{max} ")
- The frequency differential is within the configured limit (screens "synchronization df_{max} and df_{min} ")
- The phase angle is within the configured limit (screen "Slip synchroniz. Max phase")
- The input "Reply: CB is open" is energized
- The parameter "Terminal 6" is configured to "Enable/Release control"
- Terminal 6 is not energized (the control is disabled)
- Terminal 5 "Enable isolated operation / dead bus start" is energized
- Terminal 3 "Enable CB" is energized

The synchronization time monitoring must be disabled.

Isolated Operation

Isolated operation is only possible if the discrete input "Release isolated operation / dead bus start" (terminal 5) is energized. To enable the frequency controller, the parameter "frequency controller in isolated operation" must be configured as "ON". The voltage controller is only enabled if the parameter "voltage controller in isolated operation" is configured as "ON". Once the generator voltage and frequency have been adjusted to the configured set point values, the GCB will be closed.

Closing the CB Without Synchronization (Dead Bus Start)

The controller will issue a connect command for the power circuit breaker without synchronization if the following conditions are met:

- The unit is in the automatic mode (LED "Automatic" is illuminated)
- The parameter "**Gen. circ.break. Dead bus op.**" has been configured as "ON"
- The bus bar is not energized ($V_{bus} < 5\% V_{rated}$)
- The generator voltage and frequency are within the configured limits
- The discrete input "Enable isolated operation / dead bus start" (terminal 5) is energized
- The discrete input "Enable CB" (terminal 3) is energized
- The discrete input "Reply: CB is open" (terminal 4) is energized

LED "Gen CB - ON" Flashes

LED "Gen CB - ON" flashes: The controller has detected an incorrect signal state on terminal 4 "Reply: CB is open".

Possible faults:

- Terminal 4 is de-energized, signaling that the circuit breaker is closed and the generator and mains/bus bar voltage are not synchronous.

If the LED is flashing, verify that terminal 4 is wired correctly. Terminal 4 will be de-energized when the **power circuit breaker is closed** if the wiring is correct.

Control Outputs



Synchronization pulse: Energizing this relay will close the CB. The relay de-energizes after the closing pulse is issued. Exception: Synch-check operation mode.
Command: Close CB
Terminals 14/15

Ready for operation
Terminals 18/19

The contact assembly is closed when the unit is ready for operation. The relay will de-energize if the following occurs:

- The internal self-monitoring system has detected an alarm condition. Trouble-free operation of the unit cannot be guaranteed and appropriate corrective measures must be taken.
- The synchronization time monitoring system is enabled and the configured time has expired before synchronization has occurred.



NOTE

Alarm conditions must be assessed externally from the controller (i.e. a latching circuit connected with the circuit breaker control circuit).

The mains monitoring operates independently from the state of the generator circuit breaker. The circuit breaker must be blocked externally from operating (e.g. in the event of a stationary engine) when the corresponding alarm condition is detected.

Analog Controller Outputs



The analog PID controller forms a closed-loop control loop together with the controlled system (usually a first-order lag element). The parameters of the PID controller (proportional-action coefficient K_p , derivative-action time T_v and reset time T_n) can be modified individually.

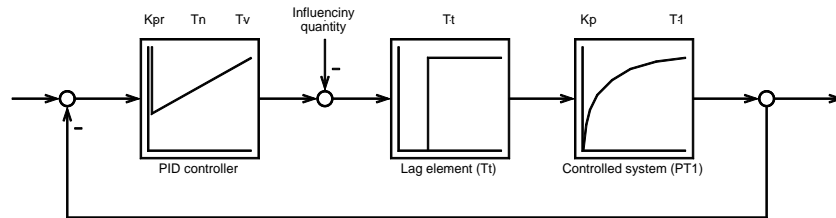

Figure 5-1: Control loop

If an abrupt disturbance variable is applied to the control loop, the reaction of the controlled system can be recorded at the output as a function of time (step response).

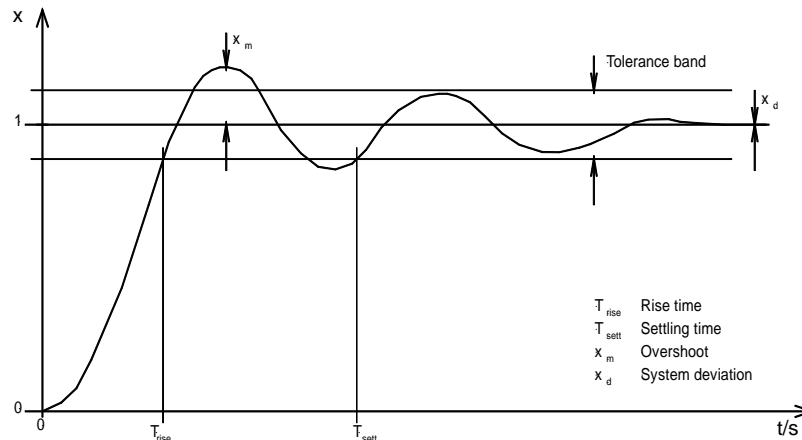

Figure 5-2: Step response (example)

Various values can be obtained from the step response; these are required for adjusting the controller to its optimum setting:

Rise time T_{rise} : Period starting when the value of the control variable leaves a predefined tolerance range for the control variable following a jump in the disturbance variable or reference input variable and ending the first time the value re-enters this range.

Setting time T_{sett} : Period starting when the value of the control variable leaves a predefined tolerance range for the control variable following a step in the disturbance variable or reference input variable and ending when the value re-enters this range permanently.

Overshoot x_m : Highest transient set point value deviation during the transition from one steady-state condition to a new steady-state condition following modification of the disturbance variable or reference input variable ($x_{m\text{optimal}} \leq 10\%$).

Permanent control deviation x_d : The present deviation between set point value and control variable in the steady-state condition (PID controller: $x_d = 0$).

From these values, the values K_P , T_n and T_V can be determined by various calculations. Moreover, it is possible, by performing various calculations, to determine the optimal controller settings, e. g. by calculating compensation or adjustment of the time constants, T-sum rule, or symmetric optimum. Other setting procedures and information may be obtained from current literature.



CAUTION

The following must be observed regarding the controller setting:

- Ensure that the emergency shutdown system is ready for use.
- While determining the critical frequency, pay attention to the amplitude and frequency.
- If the two values change in an uncontrollable manner:

→ EMERGENCY SHUTDOWN ←

Initial state: The initial state determines the start position of the controller. If the controller is switched off, the initial state can be used to output a fixed controller position. Even when the analog controller is switched off, the initial state can be freely adjusted (e.g. the speed controller can be controlled in a statically manner).

Controller output Initial state 000%	Initial state	0 to 100 %
Analog controller output setting with controller switched off.		

General settings: The setting rule described below only serves as an example. It has not been and cannot be taken into account whether this method is suitable for configuring your particular controlled system as each controlled system behaves uniquely.

There are various methods of setting a controller. The setting rules of Ziegler and Nichols are explained below (determination for abrupt disturbances on the system input); this setting method assumes a pure lag element connected in series with a first-order lag system.

1. Controller operated as a P-only controller
(where $T_n = \infty$ [screen setting: $T_n = 0$], $T_v = 0$).
2. Increase gain K_P (P gain) until the control loop oscillates continuously at $K_P = K_{Pcrit}$.



CAUTION

If the unit starts to oscillate uncontrollably, perform an emergency shutdown and change the screen setting accordingly.

3. Measuring of the cycle duration T_{crit}
4. Set the parameters:

PID controller

$$K_P = 0.6 \times K_{Pcrit}$$

$$T_n = 0.5 \times T_{crit}$$

$$T_v = 0.125 \times T_{crit}$$

PI controller

$$K_P = 0.45 \times K_{Pcrit}$$

$$T_n = 0.83 \times T_{crit}$$

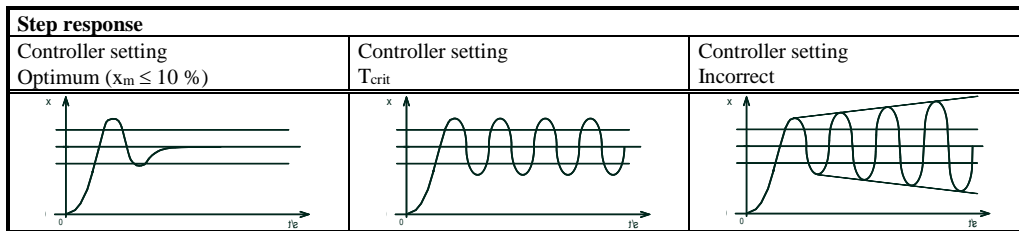

Figure 5-3: Step response - controller set-up

Pr. -sensitivity
 $K_P=000$

P gain (K_{PR}) Proportional-action coefficient

1 to 240

The proportional-action coefficient K_{PR} indicates the closed-loop control system gain. By increasing the gain, the response is increased to permit larger corrections to the variable to be controlled. The farther out of tolerance the process is the larger the response action is to return the process to the tolerance band. If the gain is configured too high, the result is excessive overshoot/undershoot of the desired value.

Reset time
 $T_n = 00,0s$

Reset time (T_n)

0.2 to 60.0 s

The reset time T_n represents the I-component of the PID controller. The reset time corrects for any offset (between set point and process variable) automatically over time by shifting the proportioning band. Reset automatically changes the output requirements until the process variable and the set point are the same. This parameter permits the user to adjust how quickly the reset attempts to correct for any offset. The reset time constant must be greater than the derivative time constant. If the reset time constant is too small, the engine will continually oscillate. If the reset time constant is too large, the engine will take too long to settle at a steady state.

Derivative act. time
 $T_v=0.00s$

Derivative-action time (T_v)

0.00 to 6.00 s

The derivative-action time T_v represents the D-component of the PID controller. By increasing this parameter, the stability of the system is increased. The controller will attempt to slow down the action of the throttle in an attempt to prevent excessive overshoot or undershoot. Essentially this is the brake for the process. This portion of the PID loop operates anywhere within the range of the process unlike reset.

Chapter 6. Display and Operating Elements

The foil of the front plate is made of coated plastics. All keys have been designed as touch-sensitive membrane switch elements. The display is a LC-display, consisting of 2 rows each with 16 characters, which are indirectly illuminated red. Contrast of the display is infinitely variable by a rotary potentiometer on the left side.

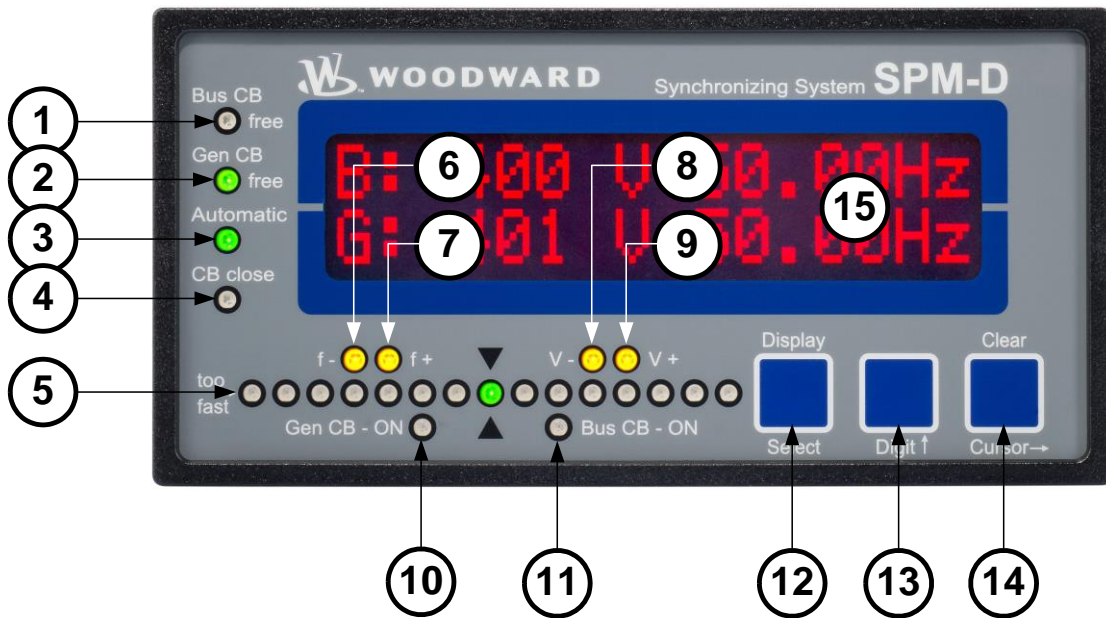

Figure 6-1: Front foil

Brief Explanation of the LEDs and Push Buttons



LEDs

No	Description	Function
1	Bus CB Free	Non-functional
2	Gen CB Free	Enable CB
3	Automatic	Automatic mode
4	CB close	Close command to the CB issued
5	Synchroscope	Display of phase position
6	f-	Governor output: frequency lower (reduce speed)
7	f+	Governor output: frequency raise (increase speed)
8	V-	Governor output: voltage lower (reduce excitation)
9	V+	Governor output: voltage raise (increase excitation)
10	Gen CB - ON	Reply: CB is closed
11	Bus CB - ON	Non-functional

Buttons

No	Description	Function
12	Display↓	Scroll display
12	Select	Confirm selection
13	Digit↑	Increase digit
14	Clear	Acknowledge alarm
14	Cursor→	Shift input position one digit to the right

Others

No	Description	Function
15	LC-Display	LC-Display
	Potentiometer	Adjust LCD contrast

LEDs



- | | | |
|----------|--|---|
| 1 | Bus CB Free
<small>here: non-functional
Color: green</small> | Enable mains circuit breaker |
| | | NOTE: This LED is non-functional, as this control is only designed to operate one circuit breaker. |
| 2 | Gen CB Free
<small>Color: green</small> | Enable power circuit breaker |
| | | The LED "Gen CB Free" indicates that the power circuit breaker has been enabled for operation. The status of the LED illuminates when the discrete input "Enable/Release CB" is energized. |
| 3 | Automatic
<small>Color: green</small> | Automatic mode |
| | | The LED "automatic" is illuminated when the unit is in automatic mode. It will turn off as soon as the control unit is switched to the configuration mode. |
| 4 | CB close
<small>Color: green</small> | CB close |
| | | The "CB close" LED illuminates when the unit outputs a closure command to the power circuit breaker during synchronization. The "CB close" LED illuminates when the relay "command: close CB" is energized. |
| 5 | LED-row: too fast →
<small>Color: red/yellow/green</small> | Phase position / Synchroscope |

The row of LEDs indicates the current phase relationship between the two voltages indicated in the display. The green LED in the center of the 15 LEDs indicates that the measured phase angle between the voltage systems is +/- 12 ° electrical. The phase position is only displayed if the controller is in automatic mode, if the difference between the frequency differential of the two measured systems is less than 2 Hz and the voltages of both systems are within the specified permissible ranges. These ranges are defined as follows:

Frequency ranges	Generator and mains	80 to 110 % f_N
Voltage ranges	Generator and mains	50 to 125 % V_N

The synchroscope LEDs can move in two directions:

left → right . If the LEDs illuminate from left to right, the generator (variable system) frequency is higher than the mains or reference voltage system (i.e. the generator or the variable system has a frequency of 60.5hz and the mains is 60hz).

right → left . If the LEDs illuminate from right to left, the generator (variable system) frequency is lower than the mains or reference voltage system (i.e. the generator respectively the variable system has a frequency of 59.5hz and the mains is 60hz).

- | | | |
|-----------|--|---|
| 6 | f-
Color: yellow | Decrease frequency governor output |
| | <i>Three position controller</i> | The "f-" LED indicates if the unit is outputting a pulse to decrease the frequency. The "f-" LED illuminates when the relay "speed lower" is energized. |
| | <i>Analog controller</i> | If the controller is issuing a reduce frequency signal, the "f-" LED will illuminate. |
| 7 | f+
Color: yellow | Increase frequency governor output |
| | <i>Three position controller</i> | The "f+" LED indicates if the unit is outputting a pulse to increase the frequency. The "f+" LED illuminates when the relay "speed raise" is energized. |
| | <i>Analog controller</i> | If the controller is issuing a increase frequency signal, the "f+" LED will illuminate. |
| 8 | V-
Color: yellow | Decrease voltage governor output |
| | <i>Three-position controller</i> | The "V-" LED indicates if the unit is outputting a pulse to decrease the voltage. The "V-" LED illuminates when the relay "voltage lower" is energized. |
| | <i>Analog controller</i> | If the controller is issuing a reduce voltage signal, the "V-" LED will illuminate. |
| 9 | V+
Color: yellow | Increase voltage governor output |
| | <i>Three-position controller</i> | The "V+" LED indicates if the unit is outputting a pulse to increase the voltage. The "V+" LED illuminates when the relay "voltage raise" is energized. |
| | <i>Analog controller</i> | If the controller is issuing a increase voltage signal, the "V+" LED will illuminate. |
| 10 | Gen CB - ON
Color: green | Power circuit breaker open/closed |
| | | The "Gen CB - ON" LED indicates if the response of the power circuit breaker is open or closed. The "Gen CB - ON" LED illuminates if the discrete input "Reply: CB is open" is not energized and will turn off as soon as the discrete input is energized. (If "LED "Gen CB - ON" Flashes" refer to page 26). |
| 11 | Bus CB - ON
here: non-functional
Color: green | Mains power circuit breaker ON |
| | | NOTE: This LED is non-functional, as this control is only designed to operate one circuit breaker. |

Push Buttons



Configuration may be performed by manually inputting the desired set points utilizing the pushbuttons and the LC display. In order to facilitate configuring the parameters, the push buttons have been enabled with an AUTOROLL function. This permits the user to advance to the next setting, configuration screen, digit, and/or cursor position more rapidly by pressing and holding the corresponding pushbutton.

12	Display / Select	Display / Select
<p>Automatic mode: <u>Display</u> - By pressing this button, the user may navigate through the displayed measured parameters and alarm messages.</p> <p>Configuration: <u>Select</u> - Advances the LC display to the next configuration screen. If any values in a configuration screen have been modified with the "Digit↑" or "Cursor→", then the "Select" button must be pressed to save the new setting. By pressing this pushbutton again, the user causes the system to display the next configuration screen.</p>		
13	Digit↑	Digit ↑
<p>Automatic mode: <u>Digit↓</u> - no function</p> <p>Configuration: <u>Digit↑</u> - Numerical values over the cursor are increased by one digit. The increase is restricted by the admissible limits (refer to the list of parameters included in the appendix). If the maximum admissible number is reached, the number automatically returns to the lowest admissible number.</p>		
14	Clear / Cursor →	Clear / Cursor→
<p>Automatic mode: <u>Clear</u> - Alarms that have occurred may be acknowledged by pressing this button as long as the fault that triggered the alarm is no longer present.</p> <p>Configuration: <u>Cursor→</u> - This button moves the cursor one position from left to right. When the cursor is under the last digit that may be changed, it may be moved to the first number of the value by pressing the "Cursor→" button again.</p>		

LC Display



15 LC-Display **LC-Display**

The two-line LC display outputs corresponding text messages and values depending on the mode that the SPM-D2 is operating. In the configuration mode, the monitoring parameters may be changed. When the SPM-D2- is in the automatic mode, the measured values are displayed.

Display Monitoring in Automatic Mode: Double Voltage / Frequency Display

LCD type 1 (V configured)

```
B: 000 V 00.00Hz
G: 000 V 00.00Hz
```

Double voltage and double frequency displays, Generator values

The generator (variable system) and reference voltage and frequency are displayed in this screen. The phase angle between the generator and reference voltage is displayed by the synchroscope (LED strip).

LCD type 2 (kV configured)

```
B: 00.0kV 00.00Hz
G: 00.0kV 00.00Hz
```

B Reference voltage and frequency
G Generator (variable system) voltage and frequency

LCD type 1 (V configured)

```
M: 000 V 00.00Hz
   000 V 000 V
```

Mains values

Mains voltage and mains frequency are monitored.

M Mains voltage and mains frequency

- upper line:
 - Phase voltage L1-L2
 - Frequency
- bottom line:
 - Phase voltage L2-L3
 - Phase voltage L3-L1

LCD type 2 (kV configured)

```
M: 00.0kV 00.00Hz
   00.0kV 00.0kV
```

Display Monitoring in Automatic Mode: Alarm Indication

```
-----
XXXXXXXXXXXXXXXXXXXX
```

Alarm indication, bottom line

The indications are displayed according to the following list:

Type of alarm	Displayed text
Synchronization time is exceeded	Synchr. time

Chapter 7. Configuration

In order to configure the device via a PC/Notebook please proceed as follows.

1. Install Toolkit^{*1} and the USB Driver for the SPM-D2 from the CD that is provided with the product or from the webpage.
2. Copy the *.wtool^{*2} and *.sid^{*2} file from the product CD to your PC or Notebook.
3. Connect the PC or Notebook and the device via an USB cable.
4. Start Toolkit
5. Select “File → open tool” and use the copied wtool file
6. Click on the “connect button” and select the network type. The USB driver is listed as a COM port.
7. “Toolkit” will establish the connection to the device and ask for a “SID” file. Please navigate to location from the copied *.sid file.
8. Now the communication with the device is active and measured values and parameter settings will be displayed.
9. Please note, that during the online communication all modified parameter will be automatically saved on the device.
10. Back up your settings by “Settings -> Save from Device to file”. A file with the extension “*.WSET” will be written to your storage media.
11. Remove the USB cable not before all settings are done and backed up.

^{*1}= To get the latest Toolkit software via the web:

- Call up <http://www.woodward.com/software> within your browser.
- Select ToolKit in the list and click the “Go” button.
- Click “More Info” to get further information about ToolKit.
- Choose the preferred software version and click “Download”
- Login with your e-mail address or register first.
The download will start immediatly.

^{*2}= To get the configuration files (WTool and the SID) from the website:

- Call up <http://www.woodward.com/software/configfiles> within your browser.
- Insert the part number (P/N) and revision of your device into the corresponding fields.
- Select "ToolKit" in the “application type” list.
- Click “Search” .
- Download the file displayed in the search result.
The file is a ZIP archive which must be extracted for use in ToolKit.



CAUTION

Please note that configuration only should be done when the system is not in operation.



NOTE

Please note the parameter list located in Appendix C of this manual.

The configuration mode is initiated by pressing the "Digit↑" and "Cursor→" pushbuttons simultaneously. The control is advanced through the various parameters by pressing the "Select" pushbutton. By pressing and holding the "Select" pushbutton the AUTOROLL function will be enabled permitting the user to rapidly advance through the parameter screens. The control unit will permit the operator to reverse up to previous screens (exception: it is not possible to reverse from the first parameter to the last parameter or to backup through the service screens). To access the previous parameter screen, press the "Select" and "Cursor→" push button simultaneously. If an entry, modification, or any other action is not carried out for 10 minutes, the unit reverts to the automatic mode.

Configure Basic Data



Parameter 1700

SPRACHE/LANGUAGE
english

Language selection

German/English

The desired language for the configuration and display screens is selected here. Either German or English may be selected.

Parameter 945

Softwareversion
x.x-y zzzzz

Softwareversion

x.x indicates the release.
-y indicates the hotfix version.
zzzzz indicates the build number (hand off)

Password Protection

The unit is equipped with a three-level code hierarchy. This permits access to different levels of selected parameters and configuration privileges. A distinction is made between:

- **Code level 0 (CL0)** - User: Third party
This code level does not allow access to the parameters. The configuration function is locked.
- **Code level 1 (CL1)** - User: Customer
This code level authorizes the user to change selected parameters. Authorization for changing the pass code is not permitted at this level.
- **Code level 2 (CL2)** - User: Commissioner
This code level grants full access privileges to all parameters. Authorization is also granted to changing pass codes. In this level, the code protection can be turned OFF (see below).

Parameter 10400

Enter code XXXX

Enter code number

0000 to 9999

When entering the configuration mode, the unit generates a random number. The appropriate code is now entered and confirmed with the "Select" button. If the random number was confirmed without being changed, the code level of the unit remains unchanged. Two four-digit code numbers (0000-9999) exist for accessing the parameters. The "Third Party" level does not have a code assigned since this level does not obtain access privileges to the configuration (protected by the code). If an incorrect pass code is entered, the control unit changes to code level 0.



NOTE

Once the code level has been set, it will remain unchanged, even after repeatedly entering the configuration mode. In the event that an incorrect code number is entered, the code level is set to CL0 and locked to the third party user level, thus preventing access to any user (reference: change passwords on page 39). Two hours after the last operation, the unit automatically reverts to code level CL0. By entering the correct code number, the appropriate privileges will be granted again.

The default code number for code level 1 (CL1) is "0001"!

The default code number for code level 2 (CL2) is "0002"!

Only in code level 2 can the password protection be disabled!

Parameter 10419

Enter Password Protection ON

Password protection

ON/OFF

ON..... The password for code level 1 or 2 must be entered to access configuration. If a wrong code number was entered, the configuration will be blocked.

OFF..... All users have direct access to all parameters, the pass code is not required.

Parameter 10417

Factory default settings	No
--------------------------	----

Factory default settings Yes/No

Yes.....Parameter 1701 (Set factory default values) will become visible.

NoParameter 1701 (Set factory default values) will be hidden.

Parameter 1701

Set factory default values	No
----------------------------	----

Set factory default values Yes/No

Please note: This parameter will become visible only if parameter 10417 “Factory default settings” is set to “Yes”.

Yes.....All parameters that are accessible via the set code level will be set back on factory defaults.

NoAll parameters will keep their current setting.

Configure Basic Settings



WARNING

The following values must be entered correctly to ensure proper monitoring of the generator. Failure to do so may lead to incorrect measuring of parameters resulting in damage to or destruction of the generator and/or personal injury or death!

Parameter 1750	System rated frequency	48.0 to 62.0 Hz
Rated Frequency fn = 00.0Hz	The system rated frequency, which in most cases is 50 Hz or 60 Hz, is entered in this screen.	
Parameter 5500	Generator frequency set point	48.0 to 62.0 Hz
Generator freq. Setpoint= 00.0Hz	The generator (variable system) frequency set point is entered in this screen. The frequency controller will reference this value for no-load and isolated operations.	
Parameter 1800	Secondary generator voltage (measuring transducer)	50 to 440 V
Gen. voltage secondary 000V	The secondary voltage for the generator (variable system) potential transformers is configured here in Volts. This entry is the reference voltage for displaying the system or primary voltage. If potential transformers are not used, the system voltage must be entered here. Example: if a generator rated for 400v is used without PTs, then 400v must be entered for this parameter.	
Parameter 1803	Secondary mains voltage (measuring transducer)	50 to 440 V
Mains voltage secondary 000V	Secondary voltage for the mains (reference system) potential transformers is configured here in Volts. This entry is the reference voltage for displaying the system or primary voltage. If potential transformers are not used, the system voltage must be entered here. Example: if a main rated for 400v is used without PTs, then 400v must be entered for this parameter.	
Parameter 1801	Primary generator voltage (measuring transducer)	0.1 to 65.0 kV
Gen. voltage primary 00.000kV	The primary voltage for the generator (variable system) is configured here in kV. This entry is the generator voltage to be displaying on the controller. If potential transformers are not used, the generator voltage must be entered here. Example: if a generator rated for 400v is used without PTs, then 00.400kV must be entered for this parameter.	
Parameter 1804	Primary mains voltage (measuring transducer)	0.1 to 65.0 kV
Mains voltage primary 00.000kV	The primary voltage for the mains (reference voltage) is configured here in kV. This entry is the generator (variable system) voltage to be displaying on the controller. If potential transformers are not used, the generator voltage must be entered here. Example: if a generator rated for 400v is used without PTs, then 00.400kV must be entered for this parameter.	
Parameter 1767	System rated voltage	70 to 420 V
Rated voltageVn = 000V	The system rated voltage is entered in this screen. The controller references this value to determine the permissible voltage range for synchronization. This setting affects the synchronization limits (refer to Table 5-3 on page 23).	

Parameter 5600

Generator set point voltage

50 to 440 V

Gen. voltage	
Setpoint	000V

The generator (variable system) voltage set point is entered in this screen. The voltage controller will reference this value for no-load and isolated operations.

Configure Controller



Entering values in the subsequent screens will result in changes to the dynamics of the controller.



CAUTION

The following values must be entered correctly to ensure proper operation of the generator. Failure to do so may lead to an uncontrollable operation resulting in damage to or destruction of the generator!

No Load Control

Parameter 6662

Automatic no-load control

ON/OFF

Automatic idle	
Running	ON

- ON**The generator frequency and voltage are maintained at the configured set points when the circuit breaker is open regardless if terminal 6 is energized or not (also refer to "Function Tables" starting on page 21)
- OFF**The generator frequency and voltage are maintained at the configured set points when the circuit breaker is open only when terminal 6 is energized (also refer to "Function Tables" starting on page 21).

Parameter 6654

Function terminal 6

Enable control / OFF

Terminal 6	
	xxxxxxx

- Enable/Release control** The controller is enabled when terminal 6 is energized. The power circuit breaker is only enabled terminal 3 (Enable CB) is energized. This setting permits the unit to be used like a SPM-A.
- OFF**The controller is enabled simultaneously with the power circuit breaker via terminal 3 (Enable CB). With this setting, the unit can be used like an ASG410+.

Frequency Controller

The following screens are not found on the SPM-D2-10, SPM-D2-10/N. They utilize a three-position controller to regulate the frequency. The SPM-D2-10/X & SPM-D2-10/XN have the option to utilize multiple methods of frequency control. The following screens show the available methods of frequency regulation. The SPM-D2-10/X & SPM-D2-10/XN will only display the screens related to the frequency controller type that is configured.

Parameter 6670	Frequency controller type	THREESTEP/ANALOG/PWM
<div style="border: 1px solid black; padding: 2px; width: fit-content; margin: 0 auto;"> f control type xxxxxxxx </div> <p style="text-align: center; font-size: small;">X & XN Packages only</p>	<p>THREESTEP The frequency controller operates as a three-position controller and outputs raise (f+) and lower pulses (f-) via the corresponding relays. The frequency and voltage controller cannot output signals at the same time.</p> <p>ANALOG ... The frequency controller operates as a continuous controller with an analog signal output (mA or V).</p> <p>PWM The frequency controller operates as a continuous controller with a pulse-width-modulated output signal and constant level.</p>	

Note: Only the screens, which pertain to the selected output signal type, will be displayed.

Three-position controller (Standard; X & XN Packages: Setting 'THREESTEP')

Parameter 5507	Frequency controller	ON/OFF
<div style="border: 1px solid black; padding: 2px; width: fit-content; margin: 0 auto;"> Freq. controller ON </div> <p style="text-align: center; font-size: small;">X & XN Packages: with 'THREESTEP' setting</p>	<p>ON..... The generator frequency is controlled by the SPM-D2. The generator frequency is controlled in various manners depending on the task (no load / isolated operation / synchronization). The subsequent screens of this function are displayed.</p> <p>OFF..... The frequency control is not performed by the SPM-D2, and the subsequent screens of this function are not displayed.</p>	

Parameter 6655	Isolated operation frequency controller	ON/OFF
<div style="border: 1px solid black; padding: 2px; width: fit-content; margin: 0 auto;"> Freq. controller Isol. oper. ON </div> <p style="text-align: center; font-size: small;">X & XN Packages: with 'THREESTEP' setting</p>	<p>ON..... In isolated operation the frequency controller is enabled.</p> <p>OFF..... In isolated operation the frequency controller is disabled.</p>	

Parameter 5503	Frequency controller set point ramp	0.1 to 99.9 Hz/s
<div style="border: 1px solid black; padding: 2px; width: fit-content; margin: 0 auto;"> Freq. Controller Ramp . = .00.0Hz/s </div> <p style="text-align: center; font-size: small;">X & XN Packages: with 'THREESTEP' setting</p>	<p>The controller increases the frequency from an initial set point to the configured frequency via a ramp. The slope of the ramp is used to determine how quickly the controller changes the frequency. The larger the value configured here, the more rapid the change in frequency.</p>	

Parameter 5550	Frequency controller dead band	0.02 to 1.00 Hz
<div style="border: 1px solid black; padding: 2px; width: fit-content; margin: 0 auto;"> Freq. controller Dead band 0.00Hz </div> <p style="text-align: center; font-size: small;">X & XN Packages: only with 'THREESTEP' setting</p>	<p>No load/Isolated operation: The generator frequency is controlled in such a manner that when in a steady state the actual frequency does not deviate from the configured generator rated frequency by more than the value configured in this screen.</p> <p>Synchronization: The generator frequency is controlled in such a manner that when in a steady state the differential frequency does not deviate from the frequency set point by more than the value configured in this screen. The mains or busbar frequency is used as the set point value.</p>	

Parameter 5551

Frequency controller ON pulse minimum time

10 to 250 ms

**Freq. controller
Time pulse>000ms**

X & XN Packages:
only with 'THREESTEP' setting

The frequency controller relay ON pulse is configured in this screen. The time period should be configured so that the frequency controller is able to respond accurately. The shortest possible time must be set in order to ensure optimum control behavior.

Parameter 5552

Frequency controller gain

0.1 to 99.9

**Freq. controller
Gain Kp 00.0**

X & XN Packages:
only with 'THREESTEP' setting

The gain factor K_p influences the operating time of the relays. By increasing the gain, the response is increased to permit larger corrections to the variable to be controlled. The farther out of tolerance the process is the larger the response action is to return the process to the tolerance band. If the gain is configured too high, the result is excessive overshoot/undershoot of the desired value.

Analog controller outputs (Only X & XN Packages: Settings 'ANALOG' and 'PWM')

Parameter 5201

Controller output signal

see table

**f control output
xxxxxxxx**

X & XN Packages only:
'ANALOG' or 'PWM' setting

If parameter 11 has been configured to "ANALOG" this parameter must be configured to the appropriate analog controller signal. The range of the analog output is configured here. To switch from a current to a voltage or PWM output, a jumper must be added to terminals 8/9 (refer to "Controller Outputs on page 18). The ranges are listed below:

Type	Setting in above configuration screen	Jumper between terminal 8/9	Signal range	Signal range min.	Signal range max.
Current	+/-20mA (+/-10V)	no	+/-20mA	-20 mA	+20 mA
	+/-10mA (+/-5V)		+/-10mA	-10 mA	+10 mA
	0 to 10mA (0 to 5V)		0 to 10mA	0 mA	10 mA
	0 to 20mA (0 to 10V)		0 to 20mA	0 mA	20 mA
	4 to 20mA		4 to 20mA	4 mA	20 mA
	10 to 0mA (5 to 0V)		10 to 0mA	10 mA	0 mA
	20 to 0mA (10 to 0V)		20 to 0mA	20 mA	0 mA
	20 to 4mA		20 to 4mA	20 mA	4 mA
Voltage	+/-20mA (+/-10V)	yes	+/-10V	-10 Vdc	+10 Vdc
	+/-10mA (+/-5V)		+/-5V	-5 Vdc	+5 Vdc
	+/-3V		+/-3V	-3 Vdc	+3 Vdc
	+/-2.5V		+/-2.5V	-2.5Vdc	+2.5 Vdc
	+/-1V		+/-1V	-1 Vdc	+1 Vdc
	0 to 10mA (0 to 5V)		0 to 5V	0 Vdc	5 Vdc
	0.5V to 4.5V		0.5 to 4.5V	0.5 Vdc	4.5 Vdc
	0 to 20mA (0 to 10V)		0 to 10V	0 Vdc	10 Vdc
	10 to 0mA (5 to 0V)		5 to 0V	5 Vdc	0 Vdc
	4.5V to 0.5V		4.5 to 0.5V	4.5 Vdc	0.5 Vdc
	20 to 0mA (10 to 0V)		10 to 0V	10 Vdc	0 Vdc

Parameter 5210

**f control output
Level PWM 00,0V**

X & XN Packages only:
'PWM' setting

PWM signal level

3.0 to 10.0 V

This configuration screen only appears if the frequency controller is configured as PWM type! The voltage amplitude for the PWM signal is configured here.

Parameter 6656

**PWM-signal
Logic positive**

X & XN Packages only:
'PWM' setting

Logic PWM signal

positive / negative

This configuration screen only appears if the frequency controller is configured as PWM type!

positive..... If the controller is outputting a PWM signal, the voltage level configured in *Parameter* is output when the signal is at 100%. When the PWM signal is at 0% the voltage level is 0 V.

negative If the controller is outputting a PWM signal, the voltage level configured in *Parameter* is output when the signal is at 0%. When the PWM signal is at 100% the voltage level is 0 V.

Parameter 5508

**f control output
Init.state 000%**

X & XN Packages only:
'ANALOG' or 'PWM' setting

Initial frequency controller state

0 to 100 %

This parameter is the set point for the frequency when the frequency controller is not enabled. The value will be entered as a percentage that relates to the minimum and maximum values for the signal output (refer to *Parameter* and *Parameter*).

Parameter 5507

**Freq. controller
ON**

X & XN Packages only:
'ANALOG' or 'PWM' setting

Frequency controller

ON/OFF

ON..... The generator frequency is controlled by the SPM-D2. The generator frequency is controlled in various manners depending on the task (no load / isolated operation / synchronization). The subsequent screens of this function are displayed.

OFF..... The frequency control is not performed by the SPM-D2, and the subsequent screens of this function are not displayed.

Parameter 6655

**Freq. controller
Isol. oper. ON**

X & XN Packages only:
'ANALOG' or 'PWM' setting'

Isolated operation frequency controller

ON/OFF

ON..... In isolated operation the frequency controller is enabled.

OFF..... In isolated operation the frequency controller is disabled.

Parameter 5503

**Freq. controller
Ramp . . . 00.0Hz/s**

X & XN Packages only:
'ANALOG' or 'PWM' setting

Frequency controller set point ramp

0.1 to 99.9 Hz/s

The controller increases the frequency from an initial set point to the configured frequency via a ramp. The slope of the ramp is used to determine how quickly the controller changes the frequency. The larger the value configured here, the more rapid the change in frequency.

Parameter 5209

Maximal value frequency controller**0 to 100%**

f control output (max.)	000%
------------------------------------	-------------

X & XN Packages only:
'ANALOG' or 'PWM' setting'

This parameter permits the user to tailor the controller to their specific needs. This value specifies the upper limit of the analog frequency controller output.

Example: The frequency controller requires a +/-4 volt input. The user would configure a +/-5 volt signal in *Parameter* and configure 90% here to limit the output to +4 volts.

Parameter 5208

Minimal value frequency controller**0 to 100%**

f control output (min.)	000%
------------------------------------	-------------

X & XN Packages only:
'ANALOG' or 'PWM' setting

This parameter permits the user to tailor the controller to their specific needs. This value specifies the lower limit of the analog frequency controller output.

Example: The frequency controller requires a +/-4 volt input. The user would configure a +/-5 volt signal in *Parameter* and configure 10% here to limit the output to -4 volts.

Parameter 5510

P gain of the frequency controller**1 to 240**

Freq. controller Gain Kp	000
-------------------------------------	------------

X & XN Packages only:
'ANALOG' or 'PWM' setting

The proportional-action coefficient K_{PR} indicates the closed-loop control system gain. By increasing the gain, the response is increased to permit larger corrections to the variable to be controlled. The farther out of tolerance the process is the larger the response action is to return the process to the tolerance band. If the gain is configured too high, the result is excessive overshoot/undershoot of the desired value (refer to "Analog Controller Outputs" on page 28).

Parameter 5511

Reset time load frequency controller**0.0 to 60.0 s**

Freq. controller Reset Tn	00.0s
--------------------------------------	--------------

X & XN Packages only:
'ANALOG' or 'PWM' setting

The reset time T_n represents the Integral component of the PID controller. The reset time corrects for any offset (between set point and process variable) automatically over time by shifting the proportioning band. Reset automatically changes the output requirements until the process variable and the set point are the same. This parameter permits the user to adjust how quickly the reset attempts to correct for any offset. The reset time constant must be greater than the derivative time constant. If the reset time constant is too small, the engine will continually oscillate. If the reset time constant is too large, the engine will take too long to settle at a steady state. The integral is disabled when $T_n=0.00$ s is configured here (refer to "Analog Controller Outputs" on page 28).

Parameter 5512

Derivative-action time frequency controller**0.00 to 6.00 s**

Freq. controller Derivat.Tv	0.00s
--	--------------

X & XN Packages only:
'ANALOG' or 'PWM' setting

The derivative-action time T_v represents the Derivative component of the PID controller. By increasing this parameter, the stability of the system is increased. The controller will attempt to slow down the action of the throttle in an attempt to prevent excessive overshoot or undershoot. Essentially this is the brake for the process. This portion of the PID loop operates anywhere within the range of the process unlike reset. The derivative is disabled when $T_v=0.00$ s is configured here (refer to "Analog Controller Outputs" on page 28).

Voltage Controller

The following screens are not found on the SPM-D2-10, SPM-D2-10/N. They utilize a three-position controller to regulate the voltage. The SPM-D2-10/X & SPM-D2-10/XN have the option to utilize multiple methods of voltage control. The following screens show the available methods of voltage regulation. The SPM-D2-10/X & SPM-D2-10/XN will only display the screens related to the voltage controller type that is configured.

Parameter 6671	Voltage controller type	THREESTEP/ANALOG
<div style="border: 1px solid black; padding: 5px; width: fit-content; margin: 0 auto;"> V contr. type xxxxxxxx </div> <p style="text-align: center; margin-top: 5px;">X & XN Packages only</p>	<p>THREESTEP The voltage controller operates as a three-position controller and outputs raise (V+) and lower pulses (V-) via the corresponding relays. The frequency and voltage controller cannot output signals at the same time.</p> <p>ANALOG The voltage controller operates as a continuous controller with an analog signal output (mA or V).</p>	

Note: Only the screens, which pertain to the selected output signal type, will be displayed.

Three-position controller (Standard; X & XN Packages: Setting 'THREESTEP')

Parameter 5607	Voltage controller	ON/OFF
<div style="border: 1px solid black; padding: 5px; width: fit-content; margin: 0 auto;"> Volt. controller ON </div> <p style="text-align: center; margin-top: 5px;">X & XN Packages: with 'THREESTEP' setting</p>	<p>ON..... Generator voltage control is performed by the SPM-D2. The generator voltage is controlled in various manners depending on the task (no load / isolated operation / synchronization). The subsequent screens of this function are displayed.</p> <p>OFF..... Voltage control is not performed by the SPM-D2, and the subsequent screens of this function are not displayed.</p>	

Parameter 6657	Voltage controller isolated mode	ON/OFF
<div style="border: 1px solid black; padding: 5px; width: fit-content; margin: 0 auto;"> Volt. controller Isol. oper. ON </div> <p style="text-align: center; margin-top: 5px;">X & XN Packages: with 'THREESTEP' setting</p>	<p>ON..... In isolated operation the voltage controller is enabled.</p> <p>OFF..... In isolated operation the voltage controller is disabled.</p>	

Parameter 5603	Voltage controller set point ramp	1 to 99 V/s
<div style="border: 1px solid black; padding: 5px; width: fit-content; margin: 0 auto;"> Volt. controller Ramp = 00V/s </div> <p style="text-align: center; margin-top: 5px;">X & XN Packages: with 'THREESTEP' setting</p>	<p>The controller increases the voltage from the initial set point to the configured voltage via a ramp. The slope of the ramp is used to determine how quickly the controller changes the voltage. The larger the value configured here, the more rapid the change in voltage.</p>	

Parameter 5650	Voltage controller dead band	0.5 to 60.0 V
<div style="border: 1px solid black; padding: 5px; width: fit-content; margin: 0 auto;"> Volt. controller Dead band 00.0V </div> <p style="text-align: center; margin-top: 5px;">X & XN Packages: only with 'THREESTEP' setting</p>	<p>No load/Isolated operation: The generator voltage is controlled in such a manner that when in a steady state the actual voltage does not deviate from the configured generator rated voltage by more than the value configured in this screen.</p> <p>Synchronization: The generator voltage is controlled in such a manner that, in a steady state, the differential voltage does not deviate from the voltage set point by more than the value configured in this screen.. The mains or busbar voltage is used as the set point value.</p>	

Parameter 5651

Voltage controller ON pulse minimum time

20 to 250 ms

Volt. controller
Time pulse>000ms

X & XN Packages:
only with 'THREESTEP' setting

The voltage controller relay ON pulse is configured in this screen. The time period should be configured so that the voltage controller is able to respond accurately. The shortest possible time must be set in order to ensure optimum control behavior.

Parameter 5652

Voltage controller gain factor

0.1 to 99.9

Volt. controller
Gain Kp 00.0

X & XN Packages:
only with 'THREESTEP' setting

The gain factor K_p influences the operating time of the relays. By increasing the gain, the response is increased to permit larger corrections to the variable to be controlled. The farther out of tolerance the process is the larger the response action is to return the process to the tolerance band. If the gain is configured too high, the result is excessive overshoot/undershoot of the desired value.

Analog controller outputs (Only X & XN Packages: Setting 'ANALOG')

Parameter 5215

Controller output signal

see table

V control output
xxxxxxx

X & XN Packages:
only with 'ANALOG' setting

If parameter 30 has been configured to "ANALOG" this parameter must be configured to the appropriate analog controller signal. The range of the analog output is configured here. To switch from a current to a voltage or PWM output, a jumper must be added to terminals 11/12 (refer to Relay Outputs on page 18). The ranges are listed below:

Type	Setting in above configuration screen	Jumper between terminal 11/12	Signal range	Signal range min.	Signal range max.
Current	+/-20mA (+/-10V)	no	+/-20mA	-20 mA	+20 mA
	+/-10mA (+/-5V)		+/-10mA	-10 mA	+10 mA
	0 to 10mA (0 to 5V)		0 to 10mA	0 mA	10 mA
	0 to 20mA (0 to 10V)		0 to 20mA	0 mA	20 mA
	4 to 20mA		4 to 20mA	4 mA	20 mA
	10 to 0mA (5 to 0V)		10 to 0mA	10 mA	0 mA
	20 to 0mA (10 to 0V)		20 to 0mA	20 mA	0 mA
	20 to 4mA		20 to 4mA	20 mA	4 mA
Voltage	+/-20mA (+/-10V)	yes	+/-10V	-10 Vdc	+10 Vdc
	+/-10mA (+/-5V)		+/-5V	-5 Vdc	+5 Vdc
	+/-3V		+/-3V	-3 Vdc	+3 Vdc
	+/-2.5V		+/-2.5V	-2.5Vdc	+2.5 Vdc
	+/-1V		+/-1V	-1 Vdc	+1 Vdc
	0 to 10mA (0 to 5V)		0 to 5V	0 Vdc	5 Vdc
	0.5V to 4.5V		0.5 to 4.5V	0.5 Vdc	4.5 Vdc
	0 to 20mA (0 to 10V)		0 to 10V	0 Vdc	10 Vdc
	10 to 0mA (5 to 0V)		5 to 0V	5 Vdc	0 Vdc
	4.5V to 0.5V		4.5 to 0.5V	4.5 Vdc	0.5 Vdc
	20 to 0mA (10 to 0V)		10 to 0V	10 Vdc	0 Vdc

Parameter 5608

V control output
Init.state 000%

X & XN Packages:
only with 'ANALOG' setting

Initial voltage controller state

0 to 100%

This parameter is the set point for the voltage when the voltage controller is not enabled. The value will be entered as a percentage that relates to the minimum and maximum values for the signal output (refer to *Parameter* and *Parameter*).

Parameter 5607

Volt. controller
ON

X & XN Packages:
only with 'ANALOG' setting

Voltage controller

ON/OFF

ON..... Generator voltage control is performed by the SPM-D2. The generator voltage is controlled in various manners depending on the task (no load / isolated operation / synchronization). The subsequent screens of this function are displayed.

OFF..... Voltage control is not performed by the SPM-D2, and the subsequent screens of this function are not displayed.

Parameter 6657

Volt. controller
Isol. oper. ON

X & XN Packages:
only with 'ANALOG' setting

Voltage controller isolated mode

ON/OFF

ON..... In isolated operation the voltage controller is enabled.

OFF..... In isolated operation the voltage controller is disabled.

Parameter 5603

Volt. Controller
Ramp = 00V/s

X & XN Packages:
only with 'ANALOG' setting

Voltage controller set point ramp

1 to 99 V/s

The controller increases the voltage from the initial set point to the configured voltage via a ramp. The slope of the ramp is used to determine how quickly the controller changes the voltage. The larger the value configured here, the more rapid the change in voltage.

Parameter 5220

V control output
(max.) 000%

X & XN Packages:
only with 'ANALOG' setting

Maximal value voltage controller

0 to 100 %

This parameter permits the user to tailor the controller to their specific needs. This value specifies the upper limit of the analog voltage controller output.

Example: The voltage controller requires a +/-4 volt input. The user would configure a +/-5 volt signal in *Parameter* and configure 90% here to limit the output to +4 volts.

Parameter 5218

V control output
(min.) 000%

X & XN Packages:
only with 'ANALOG' setting

Minimal value voltage controller

0 to 100 %

This parameter permits the user to tailor the controller to their specific needs. This value specifies the lower limit of the analog voltage controller output.

Example: The voltage controller requires a +/-4 volt input. The user would configure a +/-5 volt signal in *Parameter* and configure 10% here to limit the output to -4 volts.

Parameter 5610

P-gain voltage controller**1 to 240**

Volt. controller
Gain Kp 000

X & XN Packages:
only with 'ANALOG' setting

The proportional-action coefficient K_{PR} indicates the closed-loop control system gain. By increasing the gain, the response is increased to permit larger corrections to the variable to be controlled. The farther out of tolerance the process is the larger the response action is to return the process to the tolerance band. If the gain is configured too high, the result is excessive overshoot/undershoot of the desired value (refer to "Analog Controller Outputs" on page 28).

Parameter 5611

Voltage controller reset time**0.0 to 60.0 s**

Volt. controller
Reset Tn 00.0s

X & XN Packages:
only with 'ANALOG' setting

The reset time T_n represents the Integral component of the PID controller. The reset time corrects for any offset (between set point and process variable) automatically over time by shifting the proportioning band. Reset automatically changes the output requirements until the process variable and the set point are the same. This parameter permits the user to adjust how quickly the reset attempts to correct for any offset. The reset time constant must be greater than the derivative time constant. If the reset time constant is too small, the engine will continually oscillate. If the reset time constant is too large, the engine will take too long to settle at a steady state. The integral is disabled when $T_n=0.00$ s is configured here (refer to "Analog Controller Outputs" on page 28).

Parameter 5612

Derivative-action time voltage controller**0.00 to 6.00 s**

Volt. controller
Derivat. Tv=0.00s

X & XN Packages:
only with 'ANALOG' setting

The derivative-action time T_v represents the Derivative component of the PID controller. By increasing this parameter, the stability of the system is increased. The controller will attempt to slow down the action of the throttle in an attempt to prevent excessive overshoot or undershoot. Essentially this is the brake for the process. This portion of the PID loop operates anywhere within the range of the process unlike reset. The derivative is disabled when $T_v=0.00$ s is configured here (refer to "Analog Controller Outputs" on page 28).

Synchronization



Configure Synchronization



CAUTION

Please consider that the unit does not have an internal rotating field monitoring.

The unit assumes always a clockwise phase rotation direction of all voltage systems, which are measured.

A rotating field monitoring must be provided by the customer in order to avoid a CB closure with a counter-clockwise rotating field.

Parameter	Synchronization functions	ON/OFF
Parameter 6665	<p>Synchronizing functions ON</p> <p>ON..... The generator frequency and voltage is adjusted to the permissible differential ranges for the busbar/mains prior to issuing a connect command. The subsequent screens of this function are displayed.</p> <p>OFF..... Synchronization does not occur, but no-load control is performed if necessary. A connect command is not output. The subsequent screens of this function are not displayed.</p>	
Parameter 5701	<p>Synchronization df max = 0.00Hz</p> <p>Max. perm. frequency differential (pos. slip)</p> <p>This value specifies the upper generator frequency limit for breaker closure. A close command will not be issued until the generator and busbar/mains frequency differential falls below the value configured in this screen. A positive value corresponds to positive slip → generator frequency is greater than the busbar frequency.</p>	0.02 to 0.49 Hz
Parameter 5702	<p>Synchronization df min = -0.00Hz</p> <p>Max. perm. differential frequency (neg. slip)</p> <p>This value specifies the lower generator frequency limit for breaker closure. A close command will not be issued until the generator and busbar/mains frequency differential exceeds the value configured in this screen. A negative value corresponds to negative slip → generator frequency is less than the busbar frequency.</p>	0.00 to -0.49 Hz
Parameter 5700	<p>Synchronization dV max = 00V</p> <p>Max. perm. differential voltage</p> <p>This value specifies the maximum permissible voltage differential for breaker closure. A close command will not be issued until the generator and busbar/mains voltage differential falls below the value configured in this screen.</p>	1 to 60 V
Parameter 3416	<p>Synchronization Brk.hold T>0.00s</p> <p>Min. pulse duration of connect relay</p> <p>The duration of the connect pulse can be adjusted to meet the requirements of the switchgear.</p>	0.04 to 0.50 s

Parameter 5729

Phase matching
ON

Phase matching control

ON / OFF

ONThe synchronization is performed with phase matching control and the power circuit breaker closure is dependent upon the phase angle (refer to "Phase Matching Synchronization" on page 25). Only the parameters relating to phase matching are displayed.

OFFSynchronization is performed when the frequency and voltage differential are within the specified ranges. The circuit breaker is closed at the synchronous point (refer to "Slip Frequency Synchronization" on page 25). Only the parameters relating to slip synchronization are displayed.

Parameter 6667

Slip synchroniz.
Max phase < 00°

Phase matching control = OFF

Max. perm. differential angle in case of phase-angle-zero-control

0 to 60°

This configuration screen is displayed only if the phase matching control is disabled! A connect command is only issued when the phase angle differential is less than the value configured in this screen.

Synchronization with slip - When operating in the "slip synchronization" mode this phase angle may be set as the maximum value that a close breaker command may be issued. This is determined by the formula:

$$\Delta\phi = T_{Close} * 360^\circ * \Delta f$$

Example: If the frequency difference is 0.5Hz and the delay of the circuit breaker delay is 80ms the delta phi is determined as follows:

$$T_{Close} = 80ms, \Delta f = 0.5Hz \Rightarrow \Delta\phi = 0.08s * 360 * 0.5 = 14.4^\circ$$

As an example if the desired synchronization window is to be limited to a maximum of 10°, then the limit value of 10° would be entered here. If this parameter is not required, then the angle must be configured as 60°

Synch-check - In the operation mode "Synch-check" the phase angle differential must be less than the value configured here for the relay "Command: close CB" to be energized.

Parameter 5705

Slip synchroniz.
TClose GCB=000ms

Phase matching control = OFF

Inherent delay of circuit breaker

40 to 300 ms

This configuration screen is displayed only if the phase matching control is disabled! All circuit breakers have an inherent delay from the time the close command is issued until the circuit breaker contacts are closed. That time is configured in this screen. This permits the controller to issue the breaker closure command with enough lead-time so that the breaker contacts close at the synchronous point.

Parameter 6666

Phase matching
Max phase < 00°

Phase matching control = ON

Max. perm. differential angle

0 to 60°

This configuration screen is displayed only if the phase matching control is enabled! A connect command is only issued when the phase angle differential is less than the value configured in this screen.

Parameter 5707

Phase matching
Dwell time 00.0s

Phase matching control = ON

Dwell time for switching in case of phase-angle-zero-control

0.2 to 10.0 s

This configuration screen is displayed only if the phase matching control is enabled! Once the controller detects that the phase angle matching has been achieved, a timer is started. Only after the expiration of this dwell time is the connect command issued. If the controller detects that one of the synchronization parameters has left the required range, the dwell timer is reset.

Parameter 5505

Phase matching	
Gain	00

Phase matching control = ON

Phase-angle-zero-control gain

1 to 36

This configuration screen only appears, if the phase matching control is configured ON!

When phase matching control is enabled, this gain determines how much the output signal is changed depending on phase difference. By increasing the gain, the response is increased to permit larger corrections to the variable to be controlled resulting in longer ON time periods. The farther out of tolerance the process is the larger the response action is to return the process to the tolerance band. If the gain is configured too high, the result is excessive overshoot/undershoot of the desired value. Prior to setting the value for this gain, the frequency controller must be enabled and properly adjusted.

Parameter 5506

Phase matching	
df start	0.00Hz

Phase matching control = ON

Differential frequency for starting phase-angle-zero-control

0.02 to 0.25 Hz

This configuration screen is displayed only if the phase matching control is enabled! The control enables phase matching when the generator and busbar/mains frequency differential falls below the value configured here.

Synchronization Time Monitoring

Parameter 3060

Sync.time contr.	
Alarm	ON

Synchronization time monitoring

ON/OFF

ON..... The synchronization timer is enabled. When a synchronization operation is initiated, this timer starts to count down. If the timer expires prior to the synchronization being completed and the breaker closing, the warning message "Synchronization time" is displayed. In addition to the warning message the "Ready for operation" relay is de-energized and the synchronization operation is terminated. The alarm condition may be reset by pressing and holding the "Clear" pushbutton for at least 3 seconds or removing one of the required conditions for synchronization (e.g. de-energize terminal 3 "Release CB"). The subsequent screens of this function are displayed.

OFF..... The synchronization time is not monitored and the control will continue to attempt to synchronize until the circuit breaker is successfully closed or the synchronization it terminated. The subsequent screens of this function are not displayed.

Parameter 3063

Sync.time contr.	
Delay time	000s

Final value for synchronization time monitoring

10 to 999 s

If the synchronization time monitoring has been enabled, the control will attempt to synchronize for up to the time period configured here.

Dead Bus Start



Closing the circuit breaker may be performed even if synchronization voltage is not present. The close CB command is issued if the input "Enable CB" (terminal 3) is energized and input "Reply: CB is open" (terminal 4) signals an open circuit breaker.

Parameter 3432

Dead bus start of power circuit breaker **ON/OFF**

Gen. circ.break.
Dead bus op. ON

ONThe dead bus operation functions are enabled. The circuit breaker will be closed onto a dead bus when all dead bus start parameters have been met (refer to "Closing the CB Without Synchronization (Dead Bus Start)" on page 26). The subsequent screens of this function are displayed.

OFFThe dead bus operation functions are disabled, and the subsequent screens of this function are not displayed.

Parameter 5802

Maximum differential frequency for CB dead bus start **0.05 to 5.00 Hz**

Dead bus op. GCB
df max = 0.00Hz

The circuit breaker close command is only issued after the measured generator frequency is within the value configured here of the generator rated frequency. Example: If the generator is rated at 60Hz and 5.00Hz is configured here, the circuit breaker will be issued a close command when the generator achieves 55Hz.

Parameter 5800

Maximum differential voltage for CB dead bus start **1 to 60 V**

Dead bus op. GCB
dV max = 00V

The circuit breaker close command is only issued after the measured generator voltage is within the value configured here of the generator rated voltage. Example: If the generator is rated at 460 Volts and 60V is configured here, the circuit breaker will be issued a close command when the generator achieves 400 Volts.

Password Configuration



NOTE

Once the code level is entered, access to the configuration menus will be allowed for two hours or until another password is entered into the control. If a user needs to exit a code level then code level CL0 should be entered. This will block any configuration of the control. A user may return to CL0 by allowing the entered password to expire after two hours or by changing any one digit on the random number generated on the password screen and entering it into the unit.

Parameter 10413

Code level 1 (Customer)

0000 to 9999

Define level 1
code 0000

This parameter is only accessible with code level 2 rights. After the password has been set for this parameter, only the personnel who are assigned this password will have access rights to this code level. When the CL1 (Customer) password is entered, only select parameters may be accessed. Refer to page 39 for more information to password protection.

The default setting for this code level is

CL1 = 0 0 0 1

Parameter 10411

Code level 2 (Commissioner)

0000 to 9999

Define level 2
code 0000

This parameter is only accessible with code level 2 rights. After the password has been set for this parameter, only the personnel who are assigned this password will have access rights to this code level. When the CS2 (Commissioner) password is entered, all parameters may be accessed. Refer to page 39 for more information to password protection.

The default setting for this code level is

CL2 = 0 0 0 2

Chapter 8.

Commissioning



DANGER - HIGH VOLTAGE

When commissioning the unit, please observe all safety rules that apply to the handling of live equipment. Ensure that you know how to provide first aid in the event of an uncontrolled release of energy and that you know where the first aid kit and the nearest telephone are. Never touch any live components of the system or on the back of the system:

LIFE THREATENING



CAUTION

Only a qualified technician may commission unit. The "EMERGENCY-STOP" function must be operational prior to commissioning of the system, and must not depend on the unit for its operation.



CAUTION

Prior to commissioning, ensure that all measuring devices are connected in correct phase sequence. The connect command for the unit circuit breaker must be disconnected at the unit circuit breaker. The field rotation must be monitored for proper rotation. Any absence of or incorrect connection of voltage measuring devices or other signals may lead to malfunctions and damage the unit, the engine, and/or components connected to the unit!



CAUTION

Please consider that the unit does not have an internal rotating field monitoring.

The unit assumes always a clockwise phase rotation direction of all voltage systems, which are measured.

A rotating field monitoring must be provided by the customer in order to avoid a CB closure with a counter-clockwise rotating field.

Procedure

1. Disconnect the breaker closing circuit directly at the power circuit breakers.
2. After wiring the unit and ensuring all voltage-measuring devices are phased correctly, apply the control system voltage (24 Vdc). The "automatic" LED will illuminate.
3. By simultaneously pressing the two pushbuttons "Digit↑" and "Cursor→", the configuration mode is accessed. Prior to entering the configuration mode, ensure that the "configuration locked" discrete input is de-energized. After entering the access code number, the unit may be configured according to the application requirements (see the chapter regarding the parameters). The "automatic" LED will be extinguished.
4. Configure the control unit. The setting limits can be read either from the description of the screen or from the list of parameters at the end of the operating manual.
5. After configuring the measuring variables, the unit will display the measured values. These values should be confirmed with a calibrated measuring instrument prior to enabling any breaker or control functions. **If a measuring voltage has been wired incorrect or not at all, this may lead to an asynchronous breaker closure in an active dead bus start!**

6. Check the status of all control and auxiliary inputs and the appropriate LEDs on the front foil of the unit. Check the status of all control and auxiliary outputs as well as the setting of the controller outputs.
7. Synchronizing the power circuit breaker:
 - a) Open the power circuit breaker.
 - b) Ensure the reference voltage that the system has to synchronize to is within the permissible limits.
 - c) Energize terminal 3 "Enable CB".
 - d) If the generator voltage is 50 % lower than the rated value, the voltage controller starts to operate. Configure the controller parameters so that the set point value is efficiently controlled.
 - e) Prior to the automatic closing of the circuit breaker, ensure that all measuring values have been wired and applied correctly. At the synchronous point, verify if the synchronizing functions have been configured correctly. It is recommended that a differential voltage meter be used for this test at the power circuit breaker connection.
8. Dead bus start
 - a) Open the power circuit breaker.
 - b) Verify all conditions and measuring voltages are correct and test the close breaker command.
 - c) The power circuit breaker should close automatically.
9. After successfully closing the power circuit breaker the "Gen CB - ON" LED must illuminate.

Appendix A. Dimensions

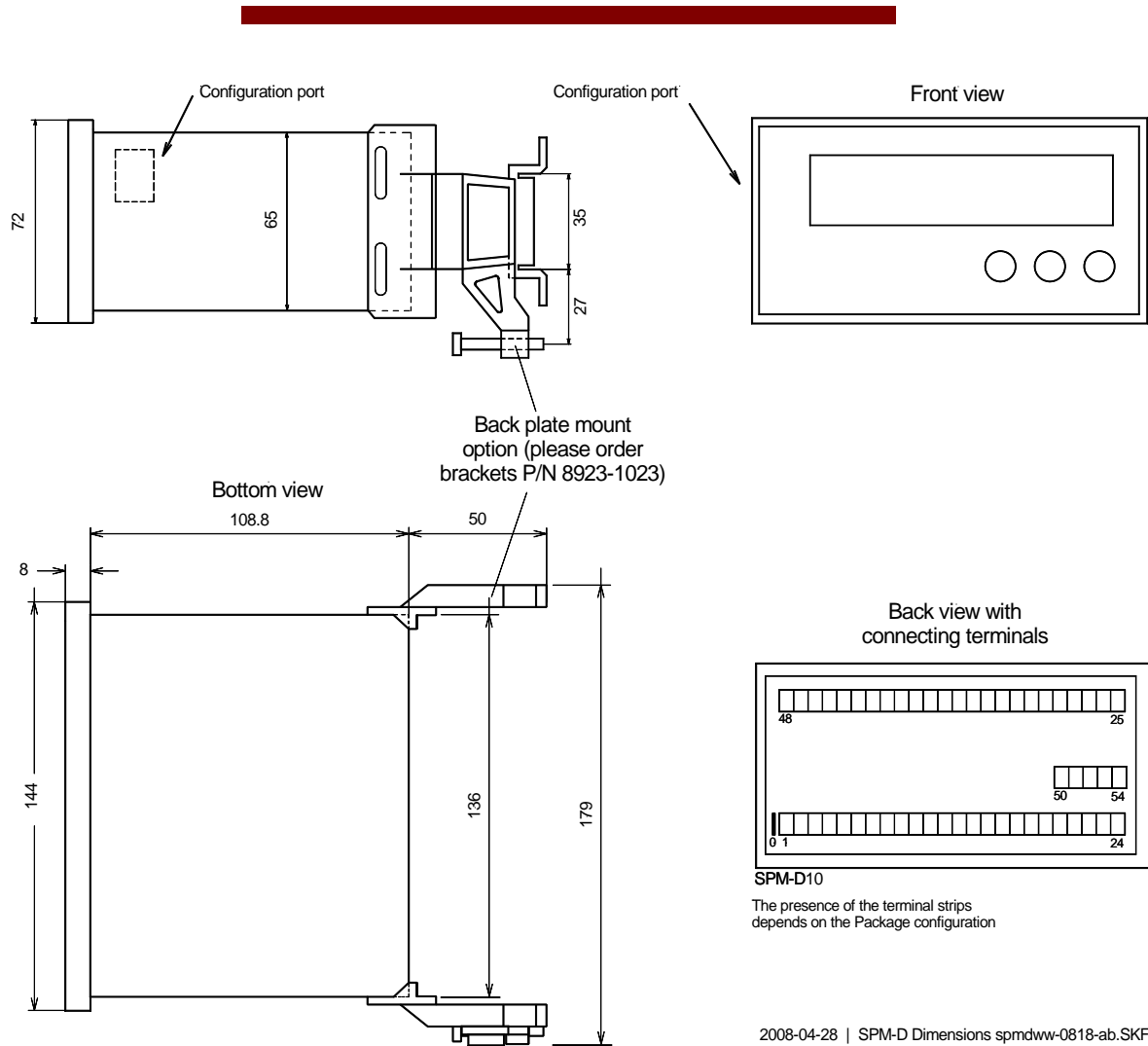

Figure 8-1: Dimensions

Appendix B. Technical Data

Measuring voltage -----	
- Measuring voltage	Rated value (V_{rated}) λ/Δ [1] 63/110 Vac [4] 230/400 Vac Maximum value V_{Ph-Ph} (UL/cUL).....[1] max. 150 Vac [4] max. 300 Vac Rated voltage $V_{Ph-ground}$ [1] 150 Vac [4] 300 Vac Rated surge voltage [1] 2.5 kV [4] 4.0 kV
- Measuring frequency40.0 to 70.0 Hz
- Accuracy Class 1
- Linear measuring range $1.25 \times V_{rated}$
- Input resistance [1] 0.21 M Ω , [4] 0.696 M Ω
Ambient variables -----	
- Power supply	Standard, X..... 12/24 Vdc (9.5 to 32 Vdc) N & XN Packages 90 to 250 Vac / 120 to 375 Vdc; 100 to 240 Vac -15%/+10% (UL rating only)
- Intrinsic consumption	Standard, X..... max. 6 W N & XN Packagesmax. 10 W (10 VA or 10 W)
- Ambient temperature	Standard, X..... -20 to 70 °C N & XN Packages -20 to 60 °C
- Ambient humidity 95 %, not condensing
Discrete inputs ----- isolated	
- Input range ($V_{Cont, digital\ input}$) 18 to 250 Vac/dc
- Input resistance ca. 68 k Ω
Relay outputs ----- isolated	
- Make contact potential free
- Contact material AgCdO
- General purpose (GP) ($V_{Cont, relay\ output}$)	AC 2.00 Aac@250 Vac DC2.00 Adc@24 Vdc 0.36 Adc@125 Vdc 0.18 Adc@250 Vdc
- Pilot duty (PD) ($V_{Cont, relay\ output}$)	AC B300 DC1.00 Adc@24 Vdc 0.22 Adc@125 Vdc 0.10 Adc@250 Vdc
Analog outputs ----- freely scalable	
- Resolution 12 Bit
- 0/4 to 20 mA external load max. 500 Ω
- 0 to 10 Vdcinternal source resistance 500 Ω
- PWM signalmax. 10 Vdc, approx. 500 Hz

Housing -----

- TypeAPRANORM DIN 43 700
- Dimensions (W × H × D)144 × 72 × 122 mm
- Front cutout (W×H) 138 [+1.0] × 68 [+0.7] mm

- Wiring Screw-type terminals depending on
plug connector 1.5 mm² or 2.5 mm²
- Recommended tightening torque 0.4 Nm or 0.5 Nm
use 60/75 °C copper wire only
use class 1 wire only or equivalent
- Weight (24Vdc fed types) approx. 600 g
- Weight (90-250 Vac / 120 to 375 Vdc - fed types) approx. 800 g

Protection -----

- Protection systemIP42 from front with correct installation
IP54 from front with gasket (gasket: P/N 8923-1037)
IP20 from back
- Front foil insulating surface
- EMV test (CE) tested according to applicable EN guidelines
- Listings CE marking; UL listing for ordinary locations
UL/cUL listed, Ordinary Locations, File No.: E231544

Communication Interface -----

- USB Mini-Type B

Appendix C. List of Parameters

Product number P/N _____ Rev _____

Version SPM-D2-10 _____

Project _____

Serial number S/N _____ Date _____

Option	Parameter 100/400V; 1/5 A	Adjustment range	Default setting	Customer settings
CONFIGURE GENERAL PARAMETERS				
	SPRACHE/LANGUAGE	German/Englisch	English	<input type="checkbox"/> G <input type="checkbox"/> E <input type="checkbox"/> G <input type="checkbox"/> E
	Software version		7.10-0	
	Enter code	0000 to 9.999	XXXX	
	Enter code Protection	ON/OFF	OFF	<input type="checkbox"/> on <input type="checkbox"/> off <input type="checkbox"/> on <input type="checkbox"/> off
	Reset on Factory Defaults	YES/NO	NO	<input type="checkbox"/> Y <input type="checkbox"/> N <input type="checkbox"/> Y <input type="checkbox"/> N
	Allow Factory Defaults	YES/NO	NO	<input type="checkbox"/> Y <input type="checkbox"/> N <input type="checkbox"/> Y <input type="checkbox"/> N
CONFIGURE BASIC SETTINGS				
	Rated Frequency fn	48.0 to 62.0 Hz	50.0 Hz	
	Generator freq. Setpoint	48.0 to 62.0 Hz	50.0 Hz	
	Gen. voltage secondary	[1]50 to 125V/ [4]50 to 440V	100/400V	
	Mains voltage secondary	[1]50 to 125V/ [4]50 to 440V	100/400V	
	Gen. voltage primary	[1,4] 0.1 to 65.0 kV	0.1/0.4 kV	
	Mains voltage primary	[1,4] 0.1 to 65.0 kV	0.1/0.4 kV	
	Rated voltage Vn	[1] 50 to 125 V/ [4] 70 to 440 V	100/400 V	
	Gen. voltage Setpoint	[1] 50 to 125 V/ [4] 70 to 440 V	100/400 V	
CONFIGURE CONTROLLER				
	Automatic idle Running	ON/OFF	OFF	<input type="checkbox"/> on <input type="checkbox"/> off <input type="checkbox"/> on <input type="checkbox"/> off
	Terminal 6	Release control/OFF	Release con.	
	f control type	THREEP/ANA./PWM	ANALOG	
	Freq. controller	ON/OFF	ON	<input type="checkbox"/> on <input type="checkbox"/> off <input type="checkbox"/> on <input type="checkbox"/> off
	Freq. controller Isol. oper	ON/OFF	OFF	<input type="checkbox"/> on <input type="checkbox"/> off <input type="checkbox"/> on <input type="checkbox"/> off
	Freq. Controller Ramp	0.1 to 99.9 Hz/s	5.0 Hz/s	
	Freq. controller Dead band	0.02 to 1.00 Hz	0.10 Hz	
	Freq. controllerTime pulse>	10 to 250 ms	80 ms	
	Freq. controller Gain Kp	0.1 to 99.9	15.0	
	f control output	refer to table under Parameter	+/-20 mA (+/-10 V)	
	f control output Level PWM	3.0 to 10.0 V	10.0 V	
	PWM-signal Logic positive	positive/negative	positive	
	f control output Init.state	0 to 100 %	50 %	
	f control output (max.)	0 to 100 %	100 %	
	f control output (min.)	0 to 100 %	0 %	
	Freq. controller Gain Kp	1 to 240	15	
	Freq. controller Reset Tn	0.0 to 60.0 s	2.5 s	
	Freq. controller Derivat.Tv	0.00 to 6.00 s	0.00 s	
	V contr. type	THREESTEP/ANALOG	ANALOG	
	Volt. controller	ON/OFF	ON	<input type="checkbox"/> on <input type="checkbox"/> off <input type="checkbox"/> on <input type="checkbox"/> off
	Volt. controller Isol. oper.	ON/OFF	OFF	<input type="checkbox"/> on <input type="checkbox"/> off <input type="checkbox"/> on <input type="checkbox"/> off
	Volt. controller Ramp	1 to 99 V/s	25 V/s	
	Volt. controller Dead band	[1] 0.1 to 15 / [4] 0.5 to 60 V	[1] 1 / [4] 2 V	
	Volt. controllerTime pulse>	20 to 250 ms	80 ms	

Option	Parameter 100/400V; 1/5 A	Adjustment range	Default setting	Customer settings
	Volt. controller Gain Kp	0.1 to 99.9	15.0	

Option	Parameter 100/400V; 1/5 A	Adjustment range	Standard setting	Customer settings
	V control output	refer to table under <i>Parameter</i>	+/-20 mA (+/-10 V)	
	V control output Init.state.	0 to 100 %	50 %	
	V control output (max.)	0 to 100 %	100 %	
	V control output (min.)	0 to 100 %	0 %	
	Volt. controller Gain Kp	1 to 240	15	
	Volt. controller Reset Tn	0.0 to 60.0 s	2.5 s	
	Volt. controller Derivat.Tv	0.00 to 6.00 s	0.00 s	

CONFIGURE SYNCHRONIZATION

Synchronizing functions	ON/OFF	ON	<input type="checkbox"/> on <input type="checkbox"/> off	<input type="checkbox"/> on <input type="checkbox"/> off
Synchronization df max	0.02 to 0.49 Hz	0.18 Hz		
Synchronization df min	0.00 to -0.49 Hz	-0.10 Hz		
Synchronization dV max	[1] 1 to 20V/ [4] 1 to 60V	6/24 V		
Synchronization Brk.hold T>	0.04 to 0.50 s	0.20 s		
Phase matching	ON/OFF	OFF	<input type="checkbox"/> on <input type="checkbox"/> off	<input type="checkbox"/> on <input type="checkbox"/> off
Phase matching Max phase <	0 to 60°	7°		
Slip synchroniz. TClose GCB	40 to 300 ms	80 ms		
Slip synchroniz.Max phase <	0 to 60°	7°		
Phase matching Dwell time	0.2 to 10.0 s	10.0 s		
Phase matching Gain	1 to 36	2		
Phase matching df start	0.02 to 0.25 Hz	0.20 Hz		

CONFIGURE SYNCH TIME MONITORING

Sync.time contr. Alarm	ON/OFF	OFF	<input type="checkbox"/> on <input type="checkbox"/> off	<input type="checkbox"/> on <input type="checkbox"/> off
Synch. Delay time	10 to 999 s	120 s		

CONFIGURE DEAD BUS START

Gen.circ.break Dead bus op	ON/OFF	OFF	<input type="checkbox"/> on <input type="checkbox"/> off	<input type="checkbox"/> on <input type="checkbox"/> off
Dead bus op. GCB df max	0.05 to 5.00 Hz	0.25 Hz		
Dead bus op. GCB dV max	[1] 1 to 20V / [4] 1 to 60 V	10/40 V		

CONFIGURE PASSWORD

Define level 1 code	0000 to 9999	0001		
Define level 2 code	0000 to 9999	0002		

Appendix D. Service Options



Product Service Options



The following factory options are available for servicing Woodward equipment, based on the standard Woodward Product and Service Warranty (5-01-1205) that is in effect at the time the product is purchased from Woodward or the service is performed. If you are experiencing problems with installation or unsatisfactory performance of an installed system, the following options are available:

- Consult the troubleshooting guide in the manual.
- Contact Woodward technical assistance (see "How to Contact Woodward" later in this chapter) and discuss your problem. In most cases, your problem can be resolved over the phone. If not, you can select which course of action you wish to pursue based on the available services listed in this section.

Returning Equipment for Repair



If a control (or any part of an electronic control) is to be returned to Woodward for repair, please contact Woodward in advance to obtain a Return Authorization Number. When shipping the unit(s), attach a tag with the following information:

- name and location where the control is installed;
- name and phone number of contact person;
- complete Woodward part numbers (P/N) and serial number (S/N);
- description of the problem;
- instructions describing the desired repair.



CAUTION

To prevent damage to electronic components caused by improper handling, read and observe the precautions in Woodward manual 82715, *Guide for Handling and Protection of Electronic Controls, Printed Circuit Boards, and Modules*.

Packing a Control

Use the following materials when returning a complete control:

- protective caps on any connectors;
- antistatic protective bags on all electronic modules;
- packing materials that will not damage the surface of the unit;
- at least 100 mm (4 inches) of tightly packed, industry-approved packing material;
- a packing carton with double walls;
- a strong tape around the outside of the carton for increased strength.

Return Authorization Number RAN

When returning equipment to Woodward, please telephone and ask for the Customer Service Department in Stuttgart [+49 (0) 711-789 54-510]. They will help expedite the processing of your order through our distributors or local service facility. To expedite the repair process, contact Woodward in advance to obtain a Return Authorization Number, and arrange for issue of a purchase order for the unit(s) to be repaired. No work can be started until a purchase order is received.



NOTE

We highly recommend that you make arrangement in advance for return shipments. Contact a Woodward customer service representative at +49 (0) 711-789 54-510 for instructions and for a Return Authorization Number.

Replacement Parts



When ordering replacement parts for controls, include the following information:

- the part numbers P/N (XXXX-XXX) that is on the enclosure nameplate;
- the unit serial number S/N, which is also on the nameplate.

How to Contact Woodward



Please contact following address if you have questions or if you want to send a product for repair:

Woodward GmbH
Handwerkstrasse 29
70565 Stuttgart - Germany

Phone: +49 (0) 711-789 54-510 (8.00 - 16.30 German time)
Fax: +49 (0) 711-789 54-101
e-mail: stgt-info@woodward.com

For assistance outside Germany, call one of the following international Woodward facilities to obtain the address and phone number of the facility nearest your location where you will be able to get information and service.

You can also contact the Woodward Customer Service Department or consult our worldwide directory on Woodward's website (www.woodward.com) for the name of your nearest Woodward distributor or service facility. For worldwide directory information, go to www.woodward.com/corp/locations/locations.cfm

Engineering Services



Woodward Industrial Controls Engineering Services offers the following after-sales support for Woodward products. For these services, you can contact us by telephone, by e-mail, or through the Woodward website.

- Technical support
- Product training
- Field service during commissioning

Technical Support is available through our many worldwide locations, or through our authorized distributors, depending on the product. This service can assist you with technical questions or problem solving during normal business hours. Emergency assistance is also available during non-business hours by phoning our toll-free number and stating the urgency of your problem. For technical engineering support, please contact us via our toll-free or local phone numbers, e-mail us, or use our website and reference technical support.

Product Training is available on-site from several of our worldwide facilities, or at your location, depending on the product. This training, conducted by experienced personnel, will assure that you will be able to maintain system reliability and availability. For information concerning training, please contact us via our toll-free or local phone numbers, e-mail us, or use our website and reference *customer training*.

Field Service engineering on-site support is available, depending on the product and location, from our facility in Colorado, or from one of many worldwide Woodward offices or authorized distributors. Field engineers are experienced on both Woodward products as well as on much of the non-Woodward equipment with which our products interface. For field service engineering assistance, please contact us via our toll-free or local phone numbers, e-mail us, or use our website and reference *field service*.

Technical Assistance



If you need to telephone for technical assistance, you will need to provide the following information. Please write it down here before phoning:

Contact

Your company _____

Your name _____

Phone number _____

Fax number _____

Control (see name plate)

Unit no. and Revision: P/N: _____ REV: _____

Unit type SPM-D2-10 _____

Serial number S/N _____

Description of your problem

Please be sure you have a list of all parameters available.

We appreciate your comments about the content of our publications.
Please send comments to: stgt-documentation@woodward.com
Please include the manual number from the front cover of this publication.



Woodward GmbH
Handwerkstrasse 29 - 70565 Stuttgart - Germany
Phone +49 (0) 711-789 54-510 • Fax +49 (0) 711-789 54-101
stgt-info@woodward.com

Homepage

<http://www.woodward.com>

Woodward has company-owned plants, subsidiaries, and branches, as well as authorized distributors and other authorized service and sales facilities throughout the world.

**Complete address/phone/fax/e-mail information
for all locations is available on our website (www.woodward.com).**

2016/02/Stuttgart