

MANUAL

HighTECH Line | PROTECTION TECHNOLOGY
MADE SIMPLE

MRS1 | NEGATIVE SEQUENCE RELAY



NEGATIVE SEQUENCE RELAY

Original document

English

Revision: B

**SEG Electronics reserves the right to update any portion of this publication at any time.
Information provided by SEG Electronics is believed to be correct and reliable.
However, no responsibility is assumed by SEG Electronics unless otherwise expressly undertaken.**

© SEG Electronics 1994–2020. All rights reserved.

Contents

1.	Introduction and application	4
2.	Features and characteristics	4
3.	Design	5
3.1	Connections	5
3.1.1	Analog Inputs	5
3.1.2	Output Relays.....	5
3.1.3	Blocking input.....	5
3.1.4	External reset input	5
3.2	Display.....	6
3.3	LEDs.....	7
4.	Working principle.....	8
4.1	Analog circuits	8
4.2	Digital circuits	8
4.3	Principle of negative sequence protection	9
4.3.1	Measurement principle	10
5.	Operations and settings	13
5.1	Adjustable parameters	13
5.2	Setting procedure	13
5.2.1	Pickup value for negative sequence warning current (I_{2w})	13
5.2.2	Time delay for negative sequence warning (t_w).....	13
5.2.3	Pickup value for negative sequence current (I_{2s}).....	13
5.2.4	Tripping characteristic (CHAR)	13
5.2.5	Trip delay / thermal time-constant (T)	13
5.2.6	Rated frequency	14
5.2.7	Adjustment of the slave address	14
5.3	Indication of measuring values and fault data.....	14
5.3.1	Indication of measuring values.....	14
5.3.2	Indication of fault data	14
5.4	Reset.....	14
6.	Relay testing and commissioning	15
6.1	Power-On	15
6.2	Testing the output relays.....	15
6.3	Checking the set values	15
6.4	Secondary injection test	16
6.4.1	Test equipment.....	16
6.4.2	Example of test circuit for MRS1 relay	16
6.4.3	Checking the input circuits and measured values.....	16
6.4.4	Checking the operating and resetting values of the relay.....	17
6.4.5	Checking the relay operating time.....	17
6.4.6	Checking the extern blocking and reset functions	18
6.5	Primary injection test.....	18
6.6	Maintenance.....	18
7.	Technical data	19
7.1	Measuring input circuits	19
7.2	Common data.....	19
7.3	Setting ranges and steps	19
7.4	Tripping characteristic	20
7.5	Output contact ratings	20
8.	Order form	21

1. Introduction and application

The MRS1 relay is a negative sequence protection relay with universal application. It serves for negative sequence protection of three-phase generators. With a large number of different tripping characteristics and adjustment possibilities, the tripping characteristic can be made suitable for almost every type of generator with regard to its special thermal time-constant.

There is a choice between an independent or an inverse time tripping characteristic. In case of low unbalanced load, a warning is given after an adjustable time delay. In case of inadmissible high unbalanced load, the MRS1 relay trips in accordance with the set characteristic.

2. Features and characteristics

- Digital filtering of the measured values by using discrete Fourier analysis to suppress the high frequency harmonics and DC components caused by faults or system operations
- Selectable protective functions between:
definite time over current protection and inverse time over current protection
- Consideration of the thermal constant of the generator
- Storage of trip values

3. Design

3.1 Connections



Abbildung 3.1: Connection diagram

3.1.1 Analog Inputs

The three phase currents are connected to the analog input current transformers: I_{L1} (B3 - B4), I_{L2} (B5 - B6), I_{L3} (B7 - B8).

The constantly detected current measuring values are galvanic ally decoupled, filtered and finally fed to the analog / digital converter.

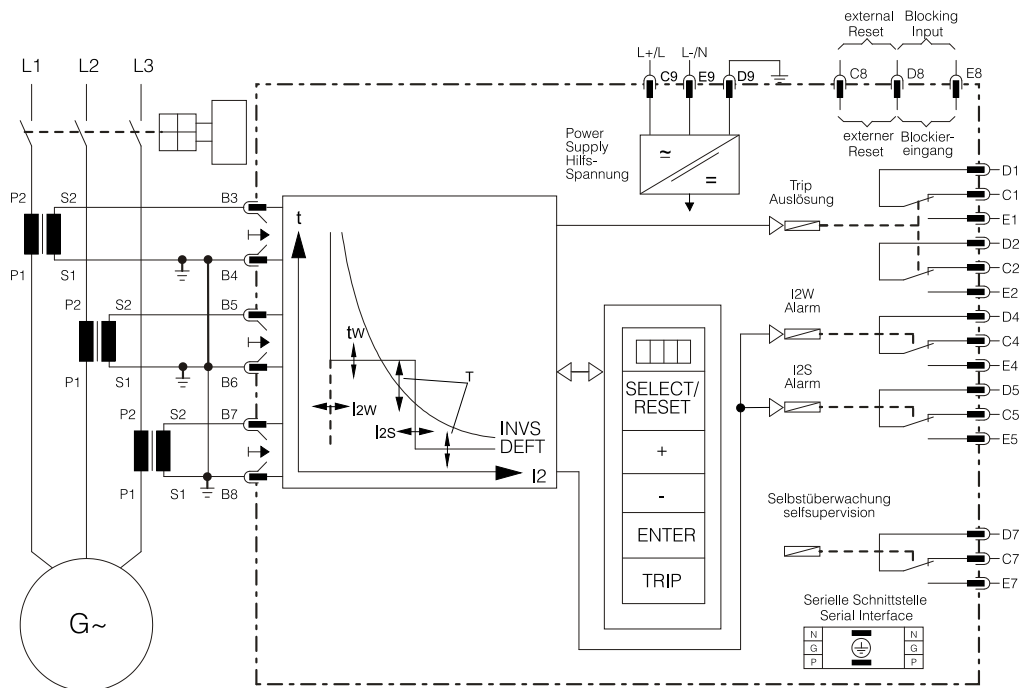
3.1.2 Output Relays

The MRS1 has 4 output relays, one of them with two change-over contacts is used for tripping, the other relays with one change-over contact each are used for indication.

- Tripping output relay C1, D1, E1, C2, D2, E2
- Indication self-supervision C7, D7, E7
- Warning for negative sequence current (I_{2w}) C4, D4, E4
- Alarm for negative sequence current pickup (I_{2s}) C5, D5, E5

All trip and alarm relays are working current relays, the relay for self supervision is an idle current relay

3.1.3 Blocking input

The tripping output relay and the signal relay for negative sequence current will be blocked if the auxiliary voltage is connected to (terminals) D8/E8.

3.1.4 External reset input

Please refer to 5.4.

3.2 Display

Function	Display shows	Pressed pushbutton	Corresponding LED
Normal operation	WW		
Measured operating values	Actual measured value, related to I_N	<SELECT/RESET> one time for each value	L1, L2, L3, I2
Setting values: negative sequence current warning	pickup value I_{2W} related to I_N	<SELECT/RESET> <+><->	I_{2W}
time delay for negative sequence current warning	setting value in seconds	<SELECT/RESET>	t_W
negative sequence current tripping	pickup value I_{2S} related to I_N	<SELECT/RESET>	I_{2S}
tripping characteristics	DEFT INVS	<SELECT/RESET>	CHAR
thermal time constant/ tripping time	Thermal time constant in case of „INVS“ or tripping time in case of „DEFT“ in seconds	<SELECT/RESET>	T
Function blockade	EXIT	<+> until max. setting value	LED of blocked parameter
Nominal frequency	$f = 50$; $f = 60$	<SELECT/RESET> <+><->	
Slave address of serial interface	1 - 32	<SELECT/RESET>	RS
Recorded fault data	I_{L1} , I_{L2} , I_{L3} , I2	<SELECT/RESET> one time for each phase	L1, L2, L3, I2, >, >>
Save parameter?	SAV?	<ENTER>	
Save parameter!	SAV!	<ENTER> for about 3 s	
Software version	First part (e.g. D02-) Sec. part (e.g. 6.01)	<TRIP> one time for each part	
Manual trip	TRI?	<TRIP> three times	
Inquire password	PSW?	<SELECT/RESET> <+><-><ENTER>	
Relay tripped	TRIP	<TRIP> or after fault tripping	
Secret password input	XXXX	<SELECT/RESET> <+><-><ENTER>	
System reset	WW	<SELECT/RESET> for about 3 s	

Table 3.1: possible indication messages on the display

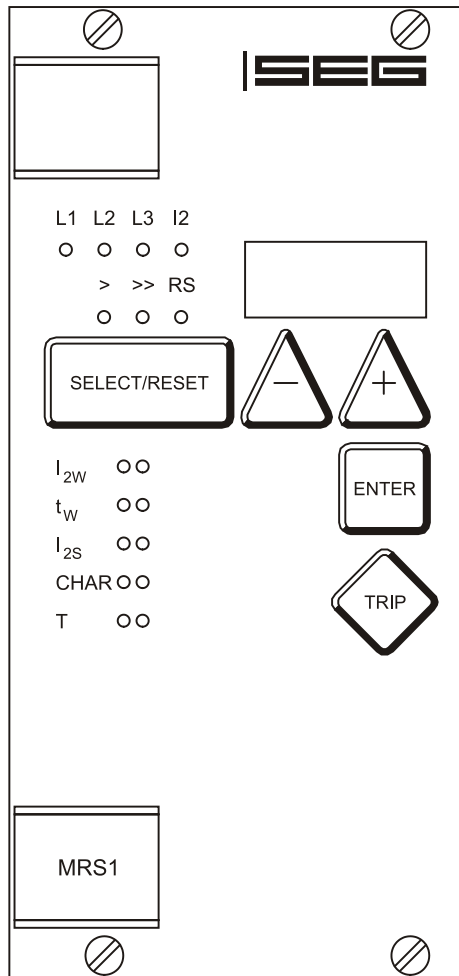

Figure 3.1: Front plate

3.3 LEDs

The LEDs L1, L2, L3 and I2 left to the display are bi-colored LED. Green indicates measuring, red fault values.

The LED marked with letters RS lights up during setting of the slave address of the device for serial data communication.

In accordance with the display 5 LEDs under the <SELECT/RESET> pushbutton indicate the selected menu point.

The LEDs > and >> indicate pickup of the alarm relay (LED >) or trip relay (LED >>).

4. Working principle

4.1 Analog circuits

The incoming currents from the main current transformers of the protected object are converted to voltage signals in proportion to the currents via the burdened input transformers. The noise signals caused by inductive and capacitive coupling are suppressed by an analog R-C filter circuit. The analog voltage signals are fed to the A/D-converter of the microprocessor and transformed to digital signals through Sample- and Hold- circuits. The analog signals are sampled at $f_n = 50$ Hz (60 Hz) with a sampling frequency of 800 Hz (960 Hz), namely, a sampling rate of 1.25 ms (1.04 ms) for every measuring quantity.

4.2 Digital circuits

The essential part of the MRS1 relay is a powerful microcontroller. All of the operations, from the analog digital conversion to the relay trip decision, are carried out by the microcontroller digitally. The relay program is located in an EPROM (Electrically Programmable Read-Only-Memory).

The calculated actual negative sequence current values are compared with the relay settings. If a negative sequence current exceeds the pickup value, an alarm is given and after the set trip delay has elapsed, the corresponding trip relay is activated.

The relay setting values for all parameters are stored in a parameter memory (EEPROM – Electrically Erasable Programmable Read Only Memory), so that the actual relay settings cannot be lost, even if the power supply is interrupted.

The microprocessor is supervised through a built-in "watchdog" timer. In case of a failure the watchdog timer resets the microprocessor and gives an alarm signal via the output relay "self supervision".

4.3 Principle of negative sequence protection

An unbalanced-load can be caused due to unequal distribution of current in the grid on account of unequal loading, unsymmetrical line-to-line short-circuits (one phase and two phase), line interruption and also switching operations.

Through the unbalanced-load, negative sequence currents occur in the stator, which cause higher harmonics with odd numbers in the stator winding and higher harmonics with even numbers in the rotor winding. The rotor is particularly endangered in this because the higher harmonics put extra load on the rotor winding and induce eddy currents in massive iron content of the rotor which can even lead to melting of the metal or to the destruction of the metal structure.

An unbalanced-load is, however, permissible in certain limits and with regard to the thermal loading limit of the generator. In order to avoid a premature outage of the generator in case of unbalanced-load, the tripping characteristic of the negative sequence protection should be adapted to the thermal characteristic of the generator.

Basically it is established that the better the cooling of the rotor, the lower are generally the permissible negative sequence values. This is due to the fact that with better rotor-cooling the maximum permissible symmetrical load can be chosen higher, however in relation to that, an unbalanced-load is permissible to a lesser extent. For turbo-generators the value of the permissible unbalanced-load is relatively low. Usual values are approx. 10 - 15 % of the load which is permissible with symmetrical load.

The negative sequence relay MRS1 has a large number of adjustable tripping characteristics. Protection of almost every type of generator is thereby possible.

In case of unsymmetrical short-circuits in the grid the negative sequence protection relay normally also picks up. In order to ensure selectivity, to the extent the overload carrying capacity of the generator permits it, a tripping time longer than that of the mains protection (e.g. overload protection) is to be selected.

4.3.1 Measurement principle

A rotating three-phase system can be split according to the method of "Symmetrical Components" into a positive-sequence system, a negative-sequence system and a zero-sequence system. The current in the negative-sequence system is a measure for the magnitude of the unbalanced-load. The MRS1 relay produces a negative-sequence system by rotating the current-vector I_{L2} by 240° and the current-vector I_{L3} by 120° .

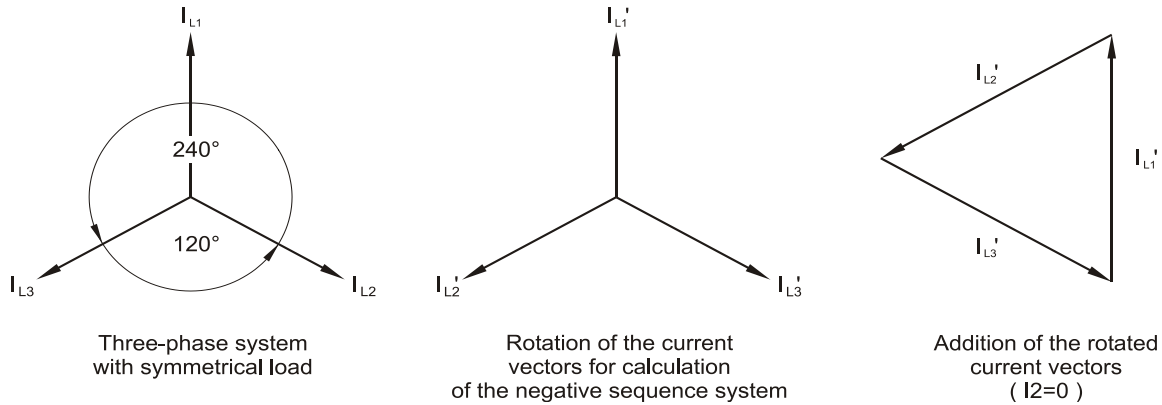

Figure 4.1: Symmetrical components

A rotating field is produced with opposite direction of rotating field. If the currents of this negative-sequence system are added, the sum is zero in case of a symmetrically load (Fig. 4.1).

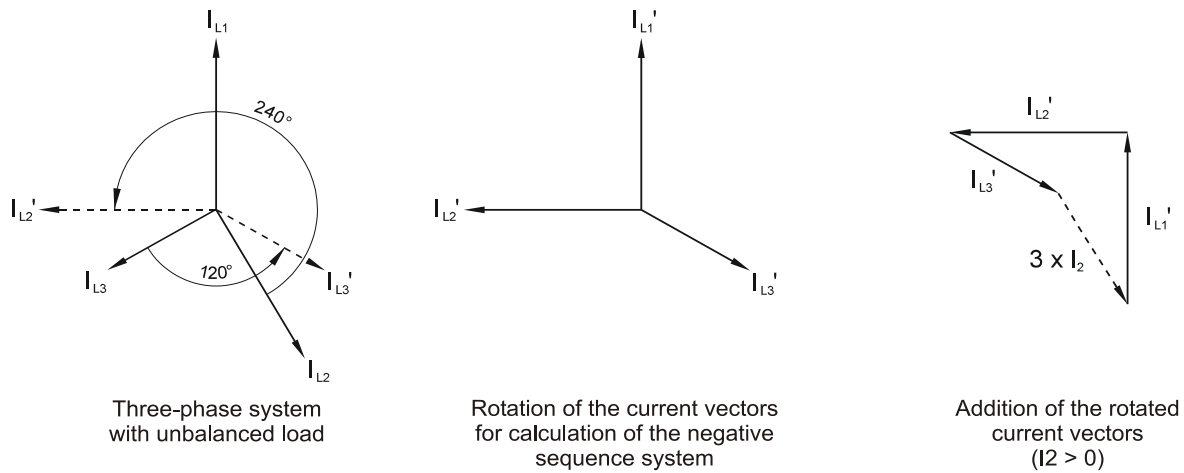

Figure 4.2: Three-phase system with unbalanced load

Fig. 4.2 shows the current vectors of an asymmetrically loaded generator. The MRS1 relay forms the negative-sequence system by rotation and adding of the current vectors. Tripping takes place according to the adjusted tripping-characteristic. For exact rotation of the current vectors by 120° or 240° , the accurate setting of the system frequency is necessary. (Refer to chapter 5.2.6)

Definition of the inverse current (I_2)

The inverse current (negative sequence current) is the resultant current in the negative-sequence system after splitting an unsymmetrical system in three symmetrical components. Example: In case of a three-phase generator which is loaded with rated current in only one phase, there is an inverse current of $I_2 = 1/3 \times I_N$.

Adaptation to the generator

For matching the MRS1 relay to the respective generator-type, two important generator-parameters are required from the generator manufacturer:

a) The continuously permissible negative sequence related to the rated current (I_N) of the generator.

$$K_2 = I_{2S}/I_N$$

This is usually given in % where I_{2S} is the continuously permissible negative sequence current.

b) The generator-constant which is dependent on design

$$K_1 = K_2^2 \times t$$

For generator with air-cooling, following values are common:

Generator capacity	<100 MVA	<20 MVA
Continuously permissible unbalanced-load K_2	approx. 8...10 % x I_N	approx. 40 % x I_N
Generator constant K_1	30	60

Further values can be taken from DIN 57 530 part 1/IEC VDE 0530 part 1.

The maximum permissible time t_{perm} of the negative sequence current I^2 is given by:

$$t_{tul} \frac{T}{(I_2/I_{2S})^2 - 1}; \text{ mit } T = K_1/K_2^2$$

The functional relationship is described graphically in chapter 7.4. In case of an occurrence of unbalanced-load, the thermal load of the generator prior to it, is taken into account. Should after a pickup of MRS1 relay, the I_{2S} value drop, the time elapsed is calculated backwards exponentially.

Example of setting

The following parameters may be given:

Nominal current of generator:	800 A
Current-transformer ratio:	1000/5
Continuously permissible Unbalanced-load K2:	40 %
Thermal generator constant K1:	$K_2^2 \times t = 60 \text{ s}$

At first the calculation is done for the generator nominal current related to the secondary side of current transformer:

$$I_{Nsec} = 800 \text{ A} \times 5 / 1000 = 4 \text{ A}$$

The continuously permissible negative sequence current related to the secondary side of the current transformer amounts to:

$$I_{2Ssec} = 0.4 \times 4 \text{ A} = 1,6 \text{ A}$$

The pickup value I_{2S} of the negative sequence currents (related to $I_N = 5\text{A}$) can be calculated to:

$$I_{2S} = 1.6 \text{ A} / 5 \text{ A} = 0,32$$

The time-constant T for the selection of the tripping characteristic can be calculated as follows:

$$T = K_1 / K_2^2 = 60 \text{ s} / 0.16 = 375 \text{ s} \Rightarrow 360 \text{ s}$$

The adjustable time-constant on the MRS1 relay amounts to 360 s.

For the warning stage I_{2W} , a somewhat lower value than I_{2S} (e.g. 35 %) is used. The setting value I_{2W} then works out as follows:

$$I_{2W} = 35 \% \times I_N / \text{Current-transformer ratio} / I_{Nsec}$$

$$I_{2W} = \frac{0.35 \cdot 800\text{A}}{\frac{1000}{5} \cdot 5\text{A}} = 0.28$$

It is recommended that the time-delay t_w for the negative sequence warning has to be adjusted to about 5 s.

5. Operations and settings

5.1 Adjustable parameters

The user can adjust 5 parameters in all:

I_{2W}	-	Negative sequence current which leads to a warning
t_W	-	Time-delay for the warning signal
I_{2S}	-	Continuously permissible negative sequence current
CHAR	-	Tripping characteristic (Inverse-time or definite time)
T	-	Thermal time-constant of the generator in case of inverse-current dependent characteristic or tripping time in case of independent characteristic

5.2 Setting procedure

For parameter setting a password has to be entered first. (Please refer to 4.4 of description "MR-Digital Multifunctional Relays")

5.2.1 Pickup value for negative sequence warning current (I_{2W})

At the time of the adjustment of the pickup value of the negative sequence warning current (I_{2W}), an indication value related to the nominal current (I_N) appears on the display.

I.e. Pickup value (I_{2W}) = indicated value x nominal current (I_N)

The desired pickup value can be adjusted with the pushbuttons <+> and <-> in the range of 0.02 to 0.5 x I_N . LED I_{2W} lights up during the adjustment.

5.2.2 Time delay for negative sequence warning (t_W)

At the time of the adjustment of the time delay for the negative sequence warning (t_W), an indication value in seconds appears on the display. The desired time delay can be set with pushbuttons <+> and <-> in the range of 0.1 to 20 s. LED t_W lights up during the adjustment.

5.2.3 Pickup value for negative sequence current (I_{2S})

At the time of adjustment of the pickup value for the negative sequence current (I_{2S}), an indication value related to the nominal current (I_N) appears on the display. The desired pickup value can be selected with pushbuttons <+> and <-> in the range of 0.02 to 0.5 x I_N . LED I_{2S} lights up during the adjustment.

5.2.4 Tripping characteristic (CHAR)

At the time of the adjustment of the tripping characteristic (CHAR), either the letters "DEFT" for independent or "INVS" for an inverse-current dependent tripping characteristic appear on the display. The desired tripping characteristic can be selected with the pushbuttons <+> and <->. LED CHAR lights up during the adjustment.

5.2.5 Trip delay / thermal time-constant (T)

If an independent tripping characteristic has been chosen as described in chapter 5.2.4 the value shown on the display corresponds to the trip delay in seconds. If an inverse current dependent tripping characteristic has been chosen the displayed value corresponds to the thermal time-constant in seconds. The desired value can be adjusted with the pushbuttons <+> and <->. LED T lights up during the adjustment.

5.2.6 Rated frequency

By pressing <SELECT> the display shows "f=50" or "f=60". The desired nominal frequency can be adjusted by <+> or <-> and then stored with <ENTER>.

5.2.7 Adjustment of the slave address

Pressing pushbuttons <+> and <-> the slave address can be set in the range of 1 -32.

5.3 Indication of measuring values and fault data

5.3.1 Indication of measuring values

- Phase current in phase 1 (LED L1)
- Phase current in phase 2 (LED L2)
- Phase current in phase 3 (LED L3)
- Negative sequence current (LED I2)

5.3.2 Indication of fault data

All faults detected by the relay are indicated on the front plate optically. LEDs I2, > and >> are available for this purpose. At the time of an unbalanced load warning, LED ">" flashes for the duration of the time delay and then changes over to steady light.

In case of a negative sequence activation, the LEDs ">" and ">>" flash for the duration of the time delay and then both of them change to steady light. After tripping, the LED "I2" lights up with an additional steady red light.

5.4 Reset

Unit MRS1 has the following three possibilities to reset the display of the unit as well as the output relay at jumper position J3=ON.

Manual Reset

- Pressing the pushbutton <SELECT/RESET> for some time (about 3 seconds)

Electrical Reset

- Through applying auxiliary voltage to C8/D8

Software Reset

- The software reset has the same effect as the <SELECT/RESET> pushbutton (see also communication protocol of RS485 interface).

The display can only be reset when the pickup is not present anymore (otherwise "TRIP" remains in display). During resetting of the display the parameters are not affected.

6. Relay testing and commissioning

The following test instructions should help to verify the protection relay performance before or during commissioning of the protection system. To avoid a relay damage and to ensure a correct relay operation, be sure that:

- the auxiliary power supply rating corresponds to the auxiliary voltage on site.
- the rated current and rated voltage of the relay correspond to the plant data on site.
- the current transformer circuits and voltage transformer circuits are connected to the relay correctly.
- all signal circuits and output relay circuits are connected correctly.

6.1 Power-On

NOTE!

Prior to switch on the auxiliary power supply, be sure that the auxiliary supply voltage corresponds with the rated data on the type plate.

Switch on the auxiliary power supply to the relay and check that the message "WW" appears on the display and the self supervision alarm relay (watchdog) is energized (Contact terminals D7 and E7 closed).

6.2 Testing the output relays

Note !

Prior to commencing this test, always block the output circuits or interrupt in another way the output circuits which can cause the tripping of the circuit breaker if the breaker operation during this test is not desired.

By pressing the pushbutton <TRIP> once the display shows you the first part of the software version of the relay (e.g. „D08-“). By pressing the pushbutton <TRIP> twice the display shows the second part of the software version of the relay (e.g. „4.01“). The software version should be quoted in all correspondence. After you have got a message "PSW?" on the display by pressing the pushbutton <TRIP> once more please enter the correct password to proceed with the test. After that the message "TRI?" will follow. Confirm this testing by means of pressing pushbutton <TRIP> again. All output relays should then be activated and the self supervision alarm relay (watchdog) be deactivated one after another with a time interval of 1 second. Thereafter, reset all output relays back to their normal positions by pressing the pushbutton <SELECT/RESET>.

6.3 Checking the set values

By repeatedly pressing the pushbutton <SELECT> all relay set values may be checked and set value modification can be done with the pushbutton <+><-> and <ENTER>. For detailed information about that, please refer to chapter 5.

For a correct relay operation, be sure that the frequency set value (f=50/60) has been selected correctly according to your system frequency (50 or 60 Hz).

6.4 Secondary injection test

6.4.1 Test equipment

- Ammeter with class 1 or better
- Auxiliary power supply with the voltage corresponding to the rated data on the type plate
- Single-phase current supply unit or three-phase current supply unit with adjustable phase shifting (adjustable from 0 to $\leq 1 \times I_N$)
- Timer to measure the operating time (Accuracy class $\leq \pm 10$ ms)
- Switching device
- Test leads and tools

6.4.2 Example of test circuit for MRS1 relay

For testing MRS1 relays, you need usually a three phase current test circuit with adjustable phase shifting to simulate various asymmetrical system conditions. Yet you can also use a single-phase test circuit. The figure 6.1 shows a simple example of a single phase test circuit with adjustable current energizing the MRS1 relay under test.

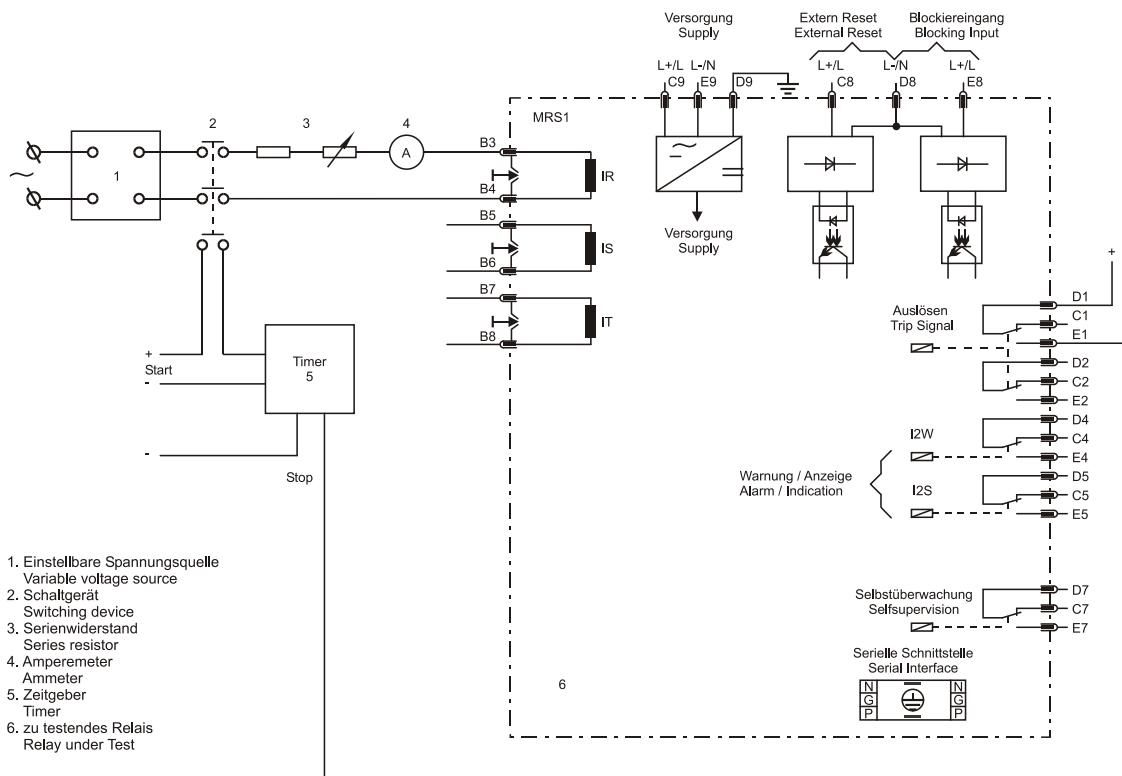

Figure 6.1: Single-phase test circuit

6.4.3 Checking the input circuits and measured values

Inject a current of rated value (1A or 5 A) in phase 1 (terminals B3-B4, as shown in figure 1), and check the measured currents on the display by pressing the pushbutton <SELECT>. The current in phase 1 (LED L1) should be indicated on display as about $1.0 \times I_N$, while the currents in phase 2 and 3 (LED L2 and L3) should be zero. Compare the reading of current in display with the reading in ammeter. The deviation must not exceed 5 %. The negative sequence current (LED I2) should be indicated on display as about $0.33 \times I_N$. The current can be also injected into the other current input circuits (Phase 2: terminals B5 - B6, Phase 3: terminals B7 - B8) in the same manner.

The negative sequence current to be measured should have the same value as in test of phase 1. By using an RMS-metering instrument, a greater deviation may be observed if the test current contains harmonics. Because the MRS1 relay measures only the fundamental component of the input signals. The harmonics will be rejected using a DFFT-digital filter. Whereas the RMS-metering instrument measures the RMS-value of the input signals.

In the following table, the negative sequence currents in different cases are summarized. If you have a three-phase test circuit with phase shifting in each output, this table will help you to check the relay under various asymmetrical system conditions:

Input currents						Negative Sequence current
$I_R (x I_N)$	Angle (°)	$I_S (x I_N)$	Angle (°)	$I_T (x I_N)$	Angle (°)	$I_2 (x I_N)$
1.00	-	0	-	0	-	0.33
0	-	1.00	-	0	-	0.33
0	-	0	-	1.00	-	0.33
1.00	0	1.00	240	1.00	120	1.00
1.00	0	1.00	120	1.00	240	0
1.00	0	1.00	180	0.00	-	0.578
0	-	1.00	0	1.00	120	0.33

6.4.4 Checking the operating and resetting values of the relay

Inject a current which is less than 3-times the relay set values in phase 1 of the relay and gradually increase the current until the relay starts, i.e. at the moment when the LED I2 lights up. Read the operating current indicated by the ammeter. The operating negative sequence current I_2 can be calculated by dividing the indicated operating current with three. (Note the difference between the operating current and the operating negative sequence current.) The deviation of the operating negative sequence current I_2 must not exceed 5 % of the set value.

Furthermore, gradually decrease the current until the relay resets, i.e. the LED I2 stop flashing quickly and begin to flashing slowly. Check that the resetting current is greater than 0.95 times the operating current.

Repeat the test on phase 2, phase 3 current input circuits in the same manner.

6.4.5 Checking the relay operating time

To check the relay operating time, a timer must be connected to the trip output relay contact. The timer should be started simultaneously with the current injection in the current input circuit and stopped by the trip relay contact. Set the current to a value corresponding to twice the operate value and inject the current instantaneously. The operating time measured by timer should have a deviation about < 3 % of the set value or < 20 ms.

Repeat the test on the other phases or with the in-verse time characteristics in the similar manner. In case of inverse time characteristics the injected current should be selected according to the characteristic curve, e.g. two times I_2s . The tripping time may be read from the characteristic curve diagram or calculated with the equations given under "technical data". The operating time for inverse time characteristics measured by timer should have a deviation about < 7.5 %. Please observe that test current during the secondary injection test must be very stable, not deviating more than 1 %. Otherwise the test results may be wrong.

6.4.6 Checking the extern blocking and reset functions

By MRS1 relays, the trip element will be inhibited by extern blocking input. To test the blocking function apply auxiliary supply voltage to extern blocking input of the relay (terminals E8/D8). Inject a test current which could cause a tripping. Observe that there is no trip and alarm.

Remove the auxiliary supply voltage from the blocking input. Inject test current to make the relay tripped (Message „TRIP“ on the display). Interrupt the test current and apply auxiliary supply voltage to extern reset input of the relay (terminals C8/D8). The display and LED indications should be reset immediately.

6.5 Primary injection test

Generally, a primary injection test could be carried out in the similar manner as the secondary injection test above described, with the difference that the protected power system should be, in this case, connected to the installed relays under test „on line“, and the test currents and voltages should be injected to the relay through the current and voltage transformers with the primary side energized. Since the cost and potential hazards are very high for such a test, primary injection tests are usually limited to very important protective relays to the power system.

Because of its powerful combined indicating and measuring functions the MRS1 may be tested in the manner of a primary injection without extra expenditures and time consumption.

In actual service, for example, the measured current values on the MRS1 relay display may be compared phase by phase with the current indications of the ammeter on the switch-board panel to verify that your relay works and measures correctly. If you have symmetrical three phase load currents in your power system, you can check if the negative sequence current measured on relay display is zero as to verify that the relay is connected to the power system correctly.

6.6 Maintenance

Maintenance testing is generally done on site at regular intervals. These intervals vary among users depending on many factors: e.g. the type of protective relays employed; the importance of the primary equipment being protected; the user's past experience with the relay, etc. For electromechanical or static relays, maintenance testing will be performed at least once a year according to the experiences. For digital re-lays like MRS1, this interval can be substantially longer. This is because that:

- the MRS1 relays are equipped with very wide self-supervision functions, so that many faults in the relay can be detected and signaled during the service. Important: The self-supervision out-put relay must be connected to a central alarm panel!
- the combined measuring functions in MRS1 relay enable supervision the relay functions during service.
- the combined TRIP test function of the MRS1 relay allows to test the relay output circuits by power system interrupt.

A testing interval of two years for maintenance will, therefore, be recommended. During a maintenance testing, the relay functions including the operating values and relay tripping characteristics as well as the operating time should be tested.

7. Technical data

MRS1 - Digital Multifunctional Relay for negative sequence protection

7.1 Measuring input circuits

Rated data:	Nominal current I_N	1A or 5A
	Nominal frequency f_N	50 Hz; 60 Hz adjustable
Power consumption in current circuit:	at $I_N = 1$ A	0.2 VA
	at $I_N = 5$ A	0.1 VA
Power consumption in voltage circuit:		< 1 VA
Thermal withstand capability in current circuit:	dynamic current withstand (half-wave)	250 x I_N
	for 1 s	100 x I_N
	for 10 s	30 x I_N
	continuously	4 x I_N

7.2 Common data

Dropout to pickup ratio:	95 % - 97 %
Returning time:	80 ms
Time lag error class index E:	± 20 ms
Minimum operating time:	100 ms
Transient overreach at instantaneous operation:	≤ 5 %
Influences to the negative sequence current measuring:	
Harmonics:	at 20 % of the third harmonic: ≤ 1,2 % at 20 % of the fifth harmonic: ≤ 0,5 %
Frequency:	in the range of $0,9 < f/f_N < 1,1$: < 2,5 %/Hz

7.3 Setting ranges and steps

	Setting range	Step	Pickup tolerances
I_{2W}	0.02...0.5 x I_N	0.005; 0.01; 0.02 x I_N	± 5 % of set value
t_W	0.1...20 s	0.1; 0.2; 0.5; 1.0 s	± 3 % or ± 10 ms
I_{2S}	0.02...0.5 x I_N	0.005; 0.01; 0.02 x I_N	± 5 % of set value
T(DEFT)	1...200 s	0.2; 0.5; 1; 2; 5; 10; 20 s	± 3 %
T(INVS)	300...3600 s	30; 60; 120; 300 s	± 7.5 % by $I_2/I_{2S} = 10$

Figure 7.1: Setting ranges and steps

Inverse time current protection

$$t = \frac{T}{(I_2/I_{2S})^2 - 1}$$

Where:	t	=	tripping time [s]
	T	=	thermal time-constant
	I_2	=	measured negative sequence current related to I_N
	I_{2S}	=	continuously permissible negative sequence current related to I_N

7.4 Tripping characteristic

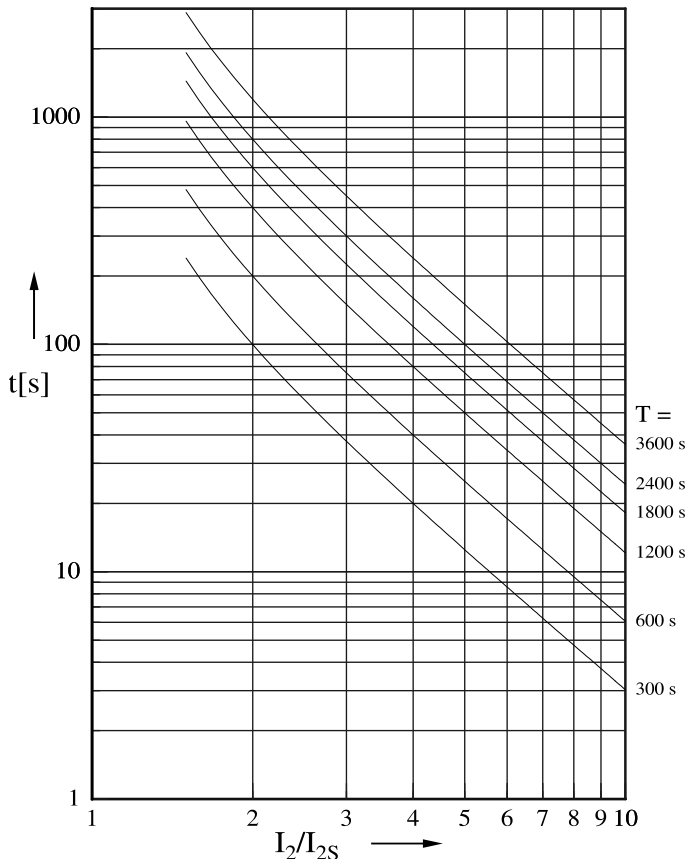

Figure 7.2: Tripping characteristic

7.5 Output contact ratings

- Number of relays: 4
- Contacts: 2 change-over contacts for trip relay
1 change-over contact for alarm relays

8. Order form

Negative sequence relay		<i>MRS1-</i>	I		
Rated current	1 A		1		
	5 A		5		
Housing (12TE)	19"-rack				A
	Flush mounting				D

Technical data subject to change without notice!

Setting-list MRS1

Project: _____ Job.-no.: _____

Function group: = _____ Location: + _____ Relay code: - _____

Relay functions: _____ Password: _____

Date: _____

Function		Unit	Default settings	Actual settings
I2w	Negative sequence current which leads to a warning	x I _N	0.02	
tw	Time delay for I2w	s	0.1	
I2s	Continuously permissible negative sequence current	x I _N	0.02	
CHA R	Tripping characteristic		DEFT	
T	Thermal time constant of inverse current (time delay)	s	1,0	
RS	Slave address of serial interface		1	

Setting of code jumpers

Code jumper	J1		J2		J3	
	Default setting	Actual setting	Default setting	Actual setting	Default setting	Actual setting
Plugged						
Not plugged	X		X		X	

HighTECH Line

<https://docs.SEGelectronics.de/mrs1>
<https://docs.SEGelectronics.de/mr>

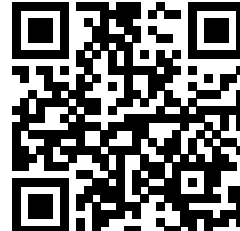

SEG Electronics GmbH reserves the right to update any portion of this publication at any time. Information provided by SEG Electronics GmbH is believed to be correct and reliable. However, SEG Electronics GmbH assumes no responsibility unless otherwise expressly undertaken.



SEG Electronics GmbH
Krefelder Weg 47 • D-47906 Kempen (Germany)
Postfach 10 07 55 (P.O.Box) • D-47884 Kempen (Germany)
Telephone: +49 (0) 21 52 145 1

Internet: www.SEGelectronics.de

Sales
Telephone: +49 (0) 21 52 145 331
Fax: +49 (0) 21 52 145 354
E-mail: info@SEGelectronics.de

Service
Telephone: +49 (0) 21 52 145 614
Fax: +49 (0) 21 52 145 354
E-mail: info@SEGelectronics.de

SEG Electronics has company-owned plants, subsidiaries, and branches, as well as authorized distributors and other authorized service and sales facilities throughout the world.

Complete address / phone / fax / email information for all locations is available on our website.