

# MANUAL

HighTECH Line | PROTECTION TECHNOLOGY  
MADE SIMPLE

**MRR1** | MULTIFUNCTIONAL GENERATOR ROTOR  
PROTECTION RELAY



## MULTIFUNCTIONAL GENERATOR ROTOR PROTECTION RELAY

Original document

English

Revision: B

**SEG Electronics reserves the right to update any portion of this publication at any time.  
Information provided by SEG Electronics is believed to be correct and reliable.  
However, no responsibility is assumed by SEG Electronics unless otherwise expressly undertaken.**

**© SEG Electronics 1994–2020. All rights reserved.**

## Contents

|           |  |           |
|-----------|--|-----------|
| <b>1.</b> | <b>Introduction and application</b>                                  | <b>4</b>  |
| <b>2.</b> | <b>Features and characteristics</b>                                  | <b>4</b>  |
| <b>3.</b> | <b>Design</b>  | <b>5</b>  |
| 3.1       | Connections  | 5         |
| 3.1.1     | Output relays  | 5         |
| 3.1.2     | Blocking input   | 5         |
| 3.1.3     | External reset input   | 5         |
| 3.2       | Display  | 6         |
| 3.3       | LEDs   | 7         |
| <b>4.</b> | <b>Working principle</b>   | <b>8</b>  |
| 4.1       | Rotor earth fault protection   | 8         |
| 4.2       | Excitation current supervision                                       | 10        |
| <b>5.</b> | <b>Operation and settings</b>  | <b>12</b> |
| 5.1       | Setting and measuring values   | 12        |
| 5.2       | Setting procedure  | 13        |
| 5.2.1     | Pickup value and tripping delay                                      | 13        |
| 5.2.2     | Setting of slave address   | 13        |
| 5.2.3     | Reset  | 14        |
| 5.3       | Blocking of protective functions and assignment of the output relays | 15        |
| 5.3.1     | Blocking of protective functions                                     | 15        |
| 5.3.2     | Assignment of the output relays                                      | 16        |
| <b>6.</b> | <b>Relay testing and commissioning</b>                               | <b>17</b> |
| 6.1       | Power-On   | 17        |
| 6.2       | Testing the output relays  | 17        |
| 6.3       | Checking the set values  | 17        |
| 6.4       | Secondary injection test   | 17        |
| 6.4.1     | Test equipment   | 17        |
| 6.4.2     | Example of a test circuit  | 18        |
| 6.4.3     | Checking the insulation measuring circuit                            | 18        |
| 6.4.4     | Checking the excitation current circuit                              | 18        |
| 6.4.5     | Checking the pickup value and reset value                            | 19        |
| 6.4.6     | Checking the tripping delay  | 19        |
| 6.5       | Real injection test  | 19        |
| 6.6       | Maintenance  | 19        |
| <b>7.</b> | <b>Technical data</b>  | <b>20</b> |
| 7.1       | Measuring input circuits   | 20        |
| 7.2       | Common data  | 20        |
| 7.3       | System data and test specifications                                  | 20        |
| 7.4       | Setting ranges and steps   | 21        |
| 7.5       | Order Form   | 22        |

# 1. Introduction and application

---

The generator rotor protection relay MRR1 combines rotor earth fault protection, excitation over- and undercurrent protection as well as rotating diode failure protection.

Thus providing a powerful protection regarding the rotor of synchronous generators, covering the following ANSI codes:

|    |                             |
|----|-----------------------------|
| 37 | DC undercurrent relay       |
| 40 | Field relay                 |
| 58 | Rectification failure relay |
| 64 | Ground detector relay       |
| 76 | DC over current relay       |

The MRR1 is recommended for synchronous generators and motors above 1 MVA rating.

The rotor earth fault element detects high- and low resistance earth faults of the rotor winding. It is equipped with two stages, one for alarm, one for trip.

The excitation current protection element supervises the DC excitation current of brushless excitor machines. The protective functions are: Undercurrent, over current and ripple detection for diode failure protection.

## 2. Features and characteristics

---

Besides features described in the general MR-description, MRR1 provides:

- Detection of high impedance earth faults with a test frequency of 0.5 Hz
- Short circuit and overvoltage proof measuring input for the earth fault protection
- Excitor current measurement galvanically isolated via Hall-transducer, measuring range 0 to 20 A
- Display of insulation resistance
- Display of the excitation current
- Excitation current over- and undercurrent protection with independent settings for current and delay time
- Detection of diode failures by supervision of the ripple component of the excitation current
- Two stage supervision of the rotor insulation resistance with independent settings for resistance and time delay
- Two trip relays, one for excitation under- and over current, one for diode failure detection
- Digital inputs for blocking and for remote reset
- Programmable function of the blocking input
- Programmable assignment of protective functions to output relays
- Remote interfacing via RS485

## 3. Design

### 3.1 Connections

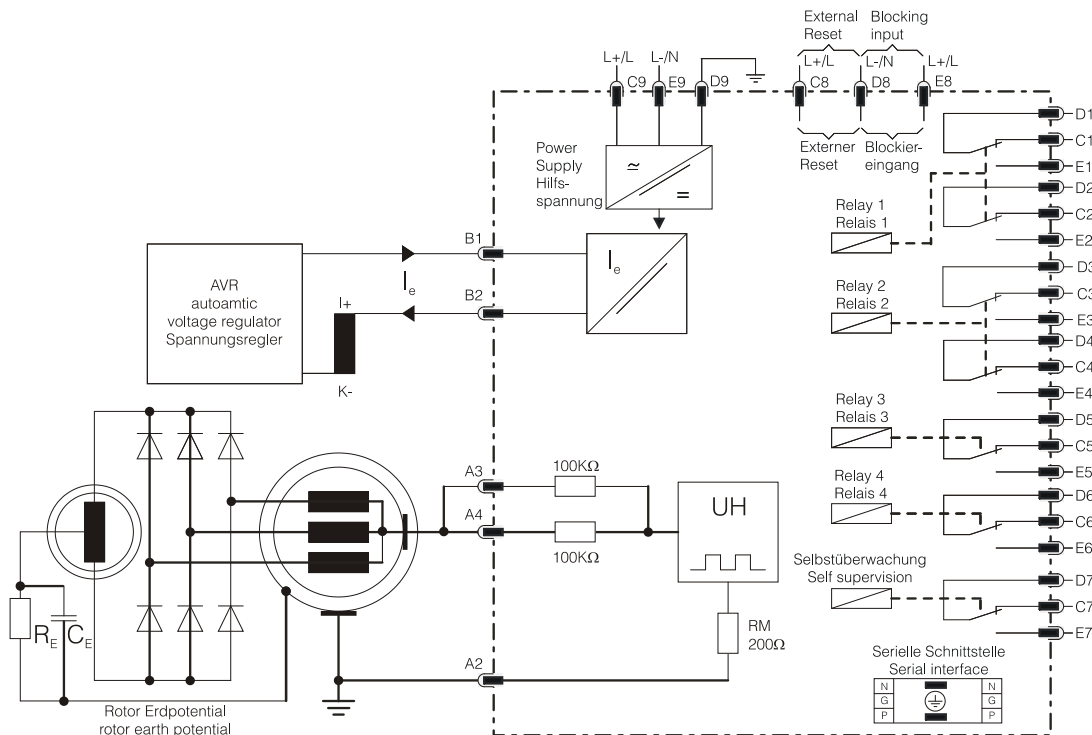

Figure 3.1: Connection diagram

#### 3.1.1 Output relays

The MRR1 has 5 output relays. Relays 1 and 2 are provided with two change-over contacts each, the other relays with one change-over contact each.

Function of relays 1 - 4 is programmable. Status of self-supervision is indicated by relay 5. The relays are allocated to the following contacts :

Output relay 1: C1, D1, E1 and C2, D2, E2

Output relay 2: C3, D3, E3 and C4, D4, E4

Output relay 3: C5, D5, E5

Output relay 4: C6, D6, E6

Output relay 5: Self-supervision (internal fault of the relay) C7, D7, E7

All relays are normally off, only the self-supervision relay is normally on.

#### 3.1.2 Blocking input

When required to inhibit the selected functions to be blocked, the auxiliary voltage has to be switched to D8/E8 (please also refer to chapter 5.3.1).

#### 3.1.3 External reset input

See chapter 5.2.2

## 3.2 Display

|                  | Function   | Anzeige in | LED / colour             |
|------------------|--|------------|--------------------------|
| Measuring values | Measuring value of the insulation resistance           | kΩ         | R green                  |
|                  | Measuring value of the excitation current              | A          | I <sub>e</sub> green     |
|                  | Ripple component of the excitation current             | %          | I <sub>r</sub> green     |
| Setting values   | Insulation resistance alarm element                    | kΩ         | R <sub>w</sub> green     |
|                  | Tripping time for insulation resistance alarm element  | s          | t <sub>Rw</sub> red      |
|                  | Insulation resistance trip element                     | kΩ         | R< green                 |
|                  | Tripping time for insulation resistance trip element   | s          | t <sub>R&lt;</sub> red   |
|                  | Setting for excitation undercurrent element            | A          | I <sub>e&lt;</sub> green |
|                  | Delay time setting for excitation undercurrent element | s          | t <sub>Ie&lt;</sub> red  |
|                  | Setting for excitation over current element            | A          | I <sub>e&gt;</sub> green |
|                  | Delay time setting for excitation over current element | s          | t <sub>Ie&gt;</sub> red  |
|                  | Setting for ripple component of the excitation current | %          | I <sub>r</sub> green     |
|                  | Delay time setting for the ripple component element    | s          | t <sub>IR</sub> red      |
|                  | Slave address for the RS485 interface                  |            | RS yellow                |

Table 3.1: Possibilities for indication by the display

Functions can be called via push button ENTER.

For changing to the next value use push button <SELECT/RESET>.

### 3.3 LEDs

All LEDs (except LED RS) are two-colored. The LEDs on the left side, next to the alphanumeric display light up green during measuring and red after tripping.

The LEDs beyond the push button <SELECT/RESET> are lit green during setting and inquiry procedure of the setting values which are printed on the left side next to the LEDs. The LEDs will light up red after activation of the setting values next to their right side.

The LED marked with letters RS lights up during setting of the slave address of the device for serial data communication (RS485).

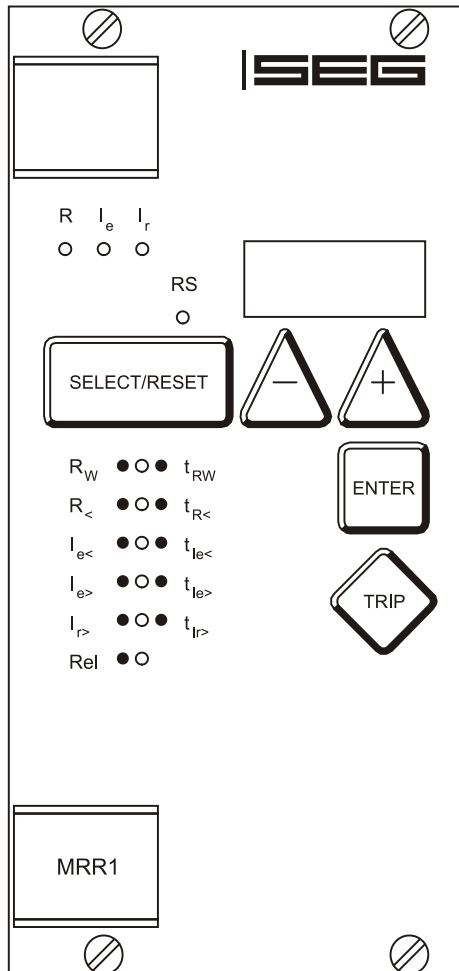

Figure 3.2: Front plate

## 4. Working principle

### 4.1 Rotor earth fault protection

A single earth fault on the field windings of a synchronous generator produces no immediate damaging effect. It must be detected and removed because of the possibility of a second earth fault that could short a part of the field winding and cause severe damage.

MRR1 provides an alarm and a trip element for the rotor earth fault protection.

The insulation resistance measurement system of the MRR1 can be used for synchronous generators of both types, with and without brushes.

It works with a low frequency alternating test voltage (0,51 Hz,  $\pm 24V$ ) which is connected via slip rings to the main excitor winding and to rotor earth (ref. to connection diagram).

The low frequency of the test voltage is used to avoid malfunction due to the field-to-earth capacitance ( $C_E$ ) which can reach values up to  $1 \mu F$  on large generators. The test voltage is fed via two current limiting resistors ( $R_V$ ) to both ends of the field winding. If only one end of the field winding can be connected, the terminals A3 and A4 should be paralleled.

The earth current is measured via shunt resistor  $R_M$ .

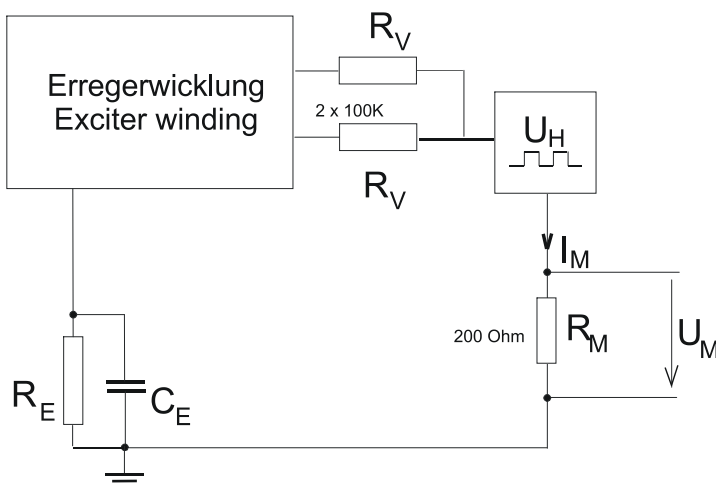

Figure 4.1: Measuring principle of the earth current

The insulation resistance measurement is based on the subsequent measurement of the shunt resistor voltage of two consecutive half cycles, i.e. positive and negative test voltage. From the differential voltage between the positive and negative measuring voltage at the end of each half cycle the insulation resistance is calculated. Thus avoiding wrong measurement due to the earth capacitance and possible voltage offsets.



Figure 4.2 explains the measuring principle:

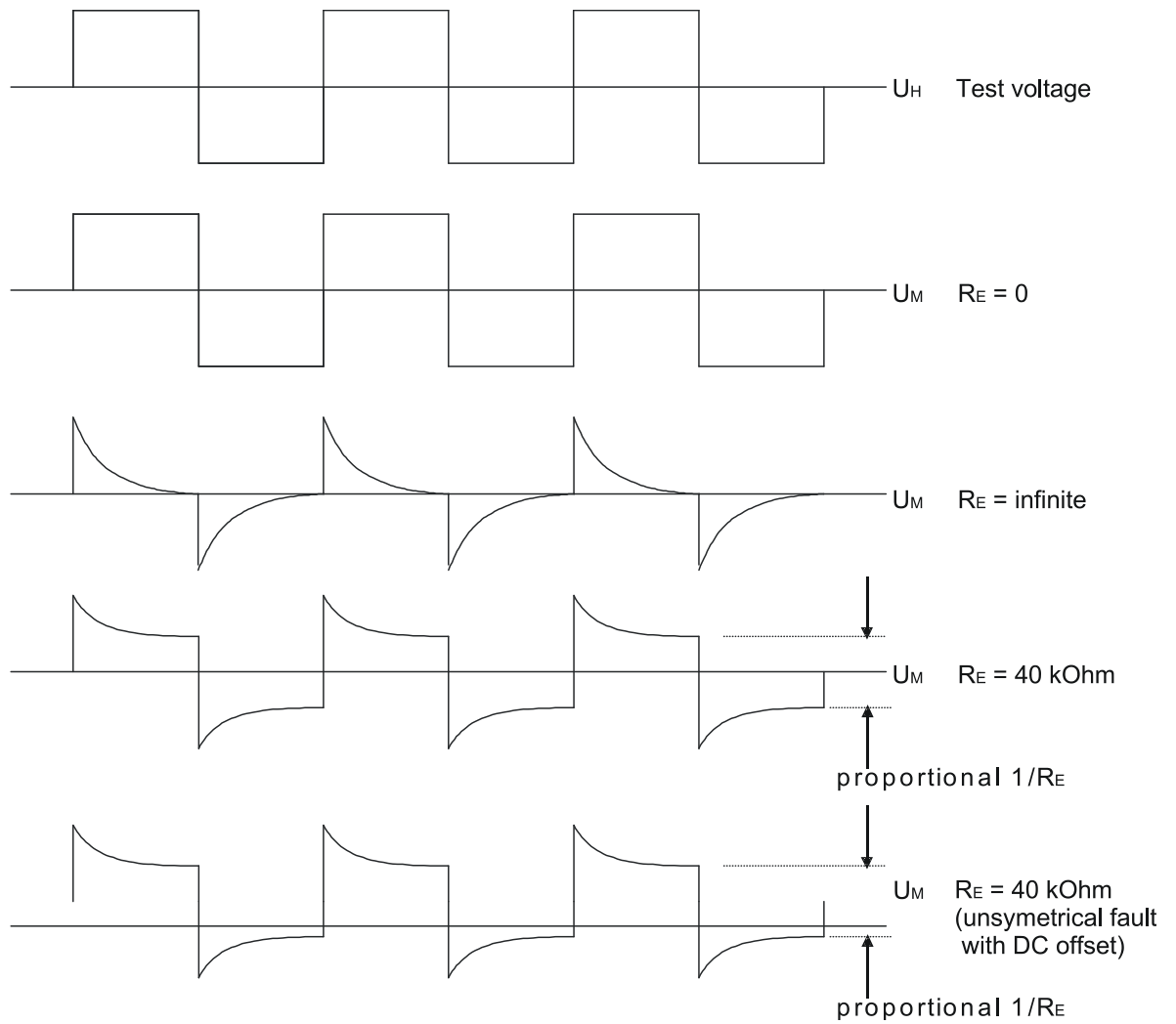

Figure 4.2: Measuring principle

## 4.2 Excitation current supervision

Failures in the excitation system of a synchronous generator may cause severe damage to the rotor of the generator as well as undesirable operating conditions:

| Failure   | Effect   |
|---|--|
| AVR failure; undercurrent in parallel operation | Excessive reactive current flow to the generator<br>⇒ System stability endangered          |
| AVR failure; undercurrent in single operation   | System under voltage if<br>⇒ System stability endangered                                   |
| AVR failure; over current in parallel operation | Excessive reactive current flow to the system<br>⇒ Thermal overload of the exciter winding |
| AVR failure; over current in single operation   | System overvoltage if in single operation<br>⇒ Thermal overload of the exciter winding     |
| AVR failure; over current                       | Rotor damage due to overheating  |
| Rotating diode open                             | Increased excitation current<br>⇒ overheating of the rotor system                          |
| Rotating diode short                            | Excessive excitation current<br>⇒ severe overheating of the rotor system                   |

Table 4.1: Effects of different failures

### Excitation current supervision:

The excitation current supervision comprises of three elements: under- and over current and ripple component measurement. Those elements cover above mentioned failures of the generator excitation system.

### Undercurrent protection:

The undercurrent protection is a definite time element. The current setting ( $I_{e<}$ ) should be chosen at about 70% of the no load excitation current of the generator. The time delay  $t_{Ie<}$  should be set to a value well above the AVR response time (e.g. 2 s), to allow transient de-excitation of the generator due to voltage regulator action.

If required the MRR1 may be blocked by connecting supply voltage to terminals D8/E8. This might be necessary during start up of the generator.

### Over current protection:

The over current protection is a definite time element. The current setting ( $I_{e>}$ ) should be chosen at about 120% of the nominal excitation current of the generator. The time delay  $t_{Ie>}$  should be set to a value well above the AVR response time and required short circuit times (e.g. 3 s), to allow transient over excitation of the generator due to voltage regulator action.

**Diode failure protection:**

The diode failure protection is based on the measurement of the ripple component of the excitation current related to the mean value of the excitation current as per following formula:

$$I_r(\%) = \frac{I_{e,max} - I_{e,min}}{I_{e=}} \cdot 100$$

Typical values for  $I_r$ :

- All diodes all right:  $I_r \approx 15\text{...}20\%$
- One diode open:  $I_r \approx 110\%$
- One diode short:  $I_r \approx 200\%$

The setting of  $I_r >$  should be chosen at about 40% to 50%. The tripping time  $t_{lr}$  should be instantaneous or with only a small delay, e.g. 200 ms. In case of a diode short the rotor system is extremely endangered!

**Hint!**

The required settings depend on various factors like:

- Required power factor of the generator
- Required minimum short circuit duration etc.

## 5. Operation and settings

### 5.1 Setting and measuring values

By pressing push button <SELECT/RESET> always the next value in sequence is displayed. At first measuring values are shown followed by the setting values. If the relay is in trip condition, display of setting values can only be achieved after pressing push button <ENTER>. Display of measuring and setting values is ended and the relay resets when push button <SELECT/RESET> is pressed for a certain time. In the display "WW" appears again.

| Measuring value |   | LED   |
|-----------------|---|-------|
| R               | Insulation resistance                   | green |
| I <sub>e</sub>  | Exciter current                         | green |
| I <sub>r</sub>  | Ripple component of the exciter current | green |

Table 5.1: Measuring values

| Setting values      |   | LED    |
|---------------------|---|--------|
| R <sub>w</sub>      | Pickup value of insulation resistance supervision (warning) | green  |
| t <sub>RW</sub>     | Tripping delay for R<                                       | red    |
| R<                  | Pickup value of insulation resistance supervision (trip)    | green  |
| t <sub>R&lt;</sub>  | Tripping delay for R<<                                      | red    |
| I <sub>e&lt;</sub>  | Pickup value exciter undercurrent element                   | green  |
| t <sub>Ie&lt;</sub> | Tripping delay for I<                                       | red    |
| I <sub>e&gt;</sub>  | Pickup value exciter over current element                   | green  |
| t <sub>Ie&gt;</sub> | Tripping delay for I>                                       | red    |
| I <sub>r</sub>      | Pickup value for ripple current supervision                 | green  |
| t <sub>Ir</sub>     | Tripping delay for t <sub>Ir</sub>                          | red    |
| RS                  | Slave address of the serial interface                       | yellow |

Table 5.2: Setting values

## 5.2 Setting procedure

Before changing a parameter a password has to be entered first (see chapter 4.4 of description "MR-digital multifunctional relay").

The gradual changing procedure is clearly explained in the following table:

| Display       | Procedure                                       | Relevant push button                |
|---------------|---|-------------------------------------|
| Actual value  | Value change                                    | <+> or <->                          |
| Changed value | Initiate storing                                | yes:<ENTER><br>no: <SELECT>         |
| SAV?          | Checkback: really storing?                      | yes:<ENTER><br>no: <SELECT>         |
| PSW?          | Enter password, a combination of 4 push buttons | <ENTER>, <+>, <-> or <SELECT/RESET> |
| SAV!          | When password correct: storing of new parameter | Hold <ENTER> for 2 s                |

Table 5.3: Changing of parameters and storing

### 5.2.1 Pickup value and tripping delay

For each element the pickup value and tripping delay can be adjusted. When the set pickup value is either exceeded or falls below, the corresponding LED flashes. After elaps of the tripping delay trip of the relay is initiated. Should the duration of pickup be shorter than the set tripping delay, this is signaled by periodical flashing of the corresponding LED. This indication can be cancelled by pressing push button <SELECT/RESET>.

Complete blocking of an element :

An element is blocked when the parameter is set to EXIT by pressing repeatedly push button <-> or <+>.

#### Warning only:

Should only excitation of an element be intended and not tripping, the respective trip delay can be set to EXIT by push button <+> (pressed repeatedly) and then pickup only is indicated by the LEDs.

### 5.2.2 Setting of slave address

When pressing push buttons <+> and <-> the slave address can be set in the range from 1 - 32, hereby LED RS lights up.

### 5.2.3 Reset

MRR1 has the following 3 possibilities to reset the display as well as the output relays at jumper position J3 = ON.  
(see also chapter 4.2 of description "MR-Digital Multifunctional Relays").

#### Manual reset

- by pressing push button <SELECT/RESET> for some time (approx. 3 seconds.)

#### Electrical reset

- by applying aux. voltage to C8/D8

#### Software reset

- software reset has the same effect as the <SELECT/RESET> push button. Please also refer here to the communication protocol of RS 485 interface.

Resetting the display is only possible when there is no pickup anymore (otherwise signal "TRIP" will still remain in the display and the relays remain activated). Resetting the relay does not change the preset parameters.

## 5.3 Blocking of protective functions and assignment of the output relays

By pressing the <ENTER> and <TRIP> push buttons simultaneously the menu for blocking of protective functions and assignment of the output relays is activated. The assignments can either be done by using the push buttons on the front plate or via serial interface RS485. The assignment mode can be terminated at any time by pressing <SELECT/RESET> push button for some time (3s).

### 5.3.1 Blocking of protective functions

After activating the menu for blocking of protective functions the following functions can be blocked selectively:

- Earth fault protection (warning)
- Earth fault protection (trip)
- Excitation undercurrent
- Excitation over current
- Rotating diode failure protection

By repeatedly pressing the <SELECT/RESET> push button, the functions to be blocked are selected one after another. The corresponding LED lights up simultaneously. The display shows "BLOC" or "NO\_B". BLOC means this function is blocked, if auxiliary voltage is applied to the external blocking input. NO\_B means applying aux. volt-age to the external blocking input has no influence on this protection function.

Blocking or not blocking a function can be selected with the push buttons <+> or <-> and be stored with <ENTER> after input of the password. Storage of the new setting to be done as shown in table 5.3.

| Display | Blocking function | Selection with push button |
|---------|-------------------|----------------------------|
| BLOC    | yes               | <+>                        |
| NO_B    | no                | <->                        |

Table 5.4: Effect of the blocking input

With the default setting all functions shown in above table are blocked via input D8/E8.

After all functions have been displayed and push button <SELECT/RESET> has been pressed, the relay switches over to the assignment mode of the output relays.

### 5.3.2 Assignment of the output relays

Unit MRR1 has five output relays. The fifth output relay is provided as permanent normally on alarm relay for self supervision. Output relays 1 - 4 are normally off and can be assigned as alarm- or trip-ping relays to the different supervision functions which can either be done by using the push buttons on the front plate or via serial interface RS485. The assignment of the output relays is similar to the setting of parameters, however, only in the assignment mode. By pressing push buttons <ENTER> and <TRIP> simultaneously, the assignment mode is selected.

The assignment of the relays will be done as follows:

LEDs  $R_w$ ,  $R_{<}$ ,  $I_{e<}$ ,  $I_{e>}$  are two-colored and light up **green** when the output relays are assigned as **alarm relays** and **red** as **tripping relays**.

#### Definition:

Alarm relays are activated at pickup of the re-lay.

Tripping relays are only activated after elapse of the tripping delay.

After the assignment mode has been activated, first LED  $R_w$  and  $R_w$  light up green. Now one or several of the four output relays can be assigned to the insulation resistance supervision as alarm relays. At the same time the selected alarm relays for the insulation resistance supervision are indicated on the display. Indication "1\_ \_ \_" means that output relay 1 is assigned to this element. When the display shows "\_ \_ \_ \_", no alarm relay is assigned to this element.

The assignment of output relays 1 - 4 can be changed by pressing <+> and <-> push buttons. The selected assignment can be stored by pressing push button <ENTER> and subsequent input of the password. By pressing push button <SELECT/RESET>, LED  $R_w$  lights up red. The output relays can now be assigned to this element as tripping relays.

Relays 1 - 4 are selected in the same way as described before. By repeated pressing of the <SELECT/RESET> push button and assignment of the relays all supervision elements can be assigned separately to the output relays. The assignment mode can be terminated at any time by pressing the <SELECT/RESET> push button for some time (abt. 3 s).

|          |              | Display            | Function            | Assigned relay |   |   |   |
|----------|--------------|--------------------|---------------------|----------------|---|---|---|
| LED      | Colour       |                    |                     | 1              | 2 | 3 | 4 |
| $R_w$    | green<br>red | _ _ _ _<br>_ 2 _ _ | Warning<br>Tripping |                | x |   |   |
| $R_{<}$  | green<br>red | _ _ _ _<br>1 _ _ _ | Warning<br>Tripping | x              |   |   |   |
| $I_{e<}$ | green<br>red | _ _ _ _<br>_ _ 3 _ | Warning<br>Tripping |                |   | x |   |
| $I_{e>}$ | green<br>red | _ _ _ _<br>_ _ 3 _ | Warning<br>Tripping |                |   | x |   |
| $I_r$    | green<br>red | _ _ _ _<br>_ _ _ 4 | Warning<br>Tripping |                |   |   | x |

Table 5.5: Default assignment of the output relays

#### Note:

- The function of jumper J2 described in general description "MR Digital Multifunctional Relays" has no function. For relays without assignment mode this jumper is used for parameter setting of alarm relays (activation at pickup or tripping).
- A form is attached to this description where the setting requested by the customer can be filled-in. This form is prepared for telefax transmission and can be used for your own reference as well as for telephone queries.



## 6. Relay testing and commissioning

The following test instructions should help to verify the protection relay performance before or during commissioning of the protection system. To avoid a relay damage and to ensure a correct relay operation, be sure that:

- the auxiliary power supply rating corresponds to the auxiliary voltage on site.
- the rated values of the relay correspond to the plant data on site
- all signal circuits and output relay circuits are connected correctly.

### 6.1 Power-On

#### NOTE!

Prior to switch on the auxiliary power supply, be sure that the auxiliary supply voltage corresponds to the rated data on the type plate.

Switch on the auxiliary power supply to the relay and check that the message "WW" appears on the display and the self supervision alarm relay (watchdog) is energized (Contact terminals D7 and E7 closed).

### 6.2 Testing the output relays

#### NOTE!

Prior to commencing this test, interrupt the tripping circuit to the circuit breaker if tripping is not desired.

By pressing the push button <TRIP> once, the display shows the first part of the software version of the relay (e.g. "D08-"). By pressing the push button <TRIP> twice, the display shows the second part of the software version of the relay (e.g. "4.01"). The software version should be quoted in all correspondence. Pressing the <TRIP> button once more, the display shows "PSW?". Please enter the correct password to proceed with the test. The message "TRI?" will follow. Confirm this message by pressing the push button <TRIP> again. All output relays should then be activated and the self supervision alarm relay (watchdog) be deenergized one after another with a time interval of 1 second. Thereafter, reset all output relays back to their normal positions by pressing the push button <SELECT/RESET>.

### 6.3 Checking the set values

By repeatedly pressing the push button <SELECT/RESET>, all relay set values may be checked. Set value modification can be done with the push button <+>< > and <ENTER> (refer to chapter 5).

### 6.4 Secondary injection test

#### 6.4.1 Test equipment

- Voltmeter and ammeter with class 1 or better
- Auxiliary power supply with the voltage corresponding to the rated data on the type plate
- Single-phase voltage supply unit
- Timer to measure the operating time (Accuracy class 10 ms)
- Switching device
- Test leads and tools
- Adjustable resistance (0 - 2201 M $\Omega$ /0.6 W)

### 6.4.2 Example of a test circuit

Figure 6.1 shows a simple example of a test circuit with variable current source for testing the relay.

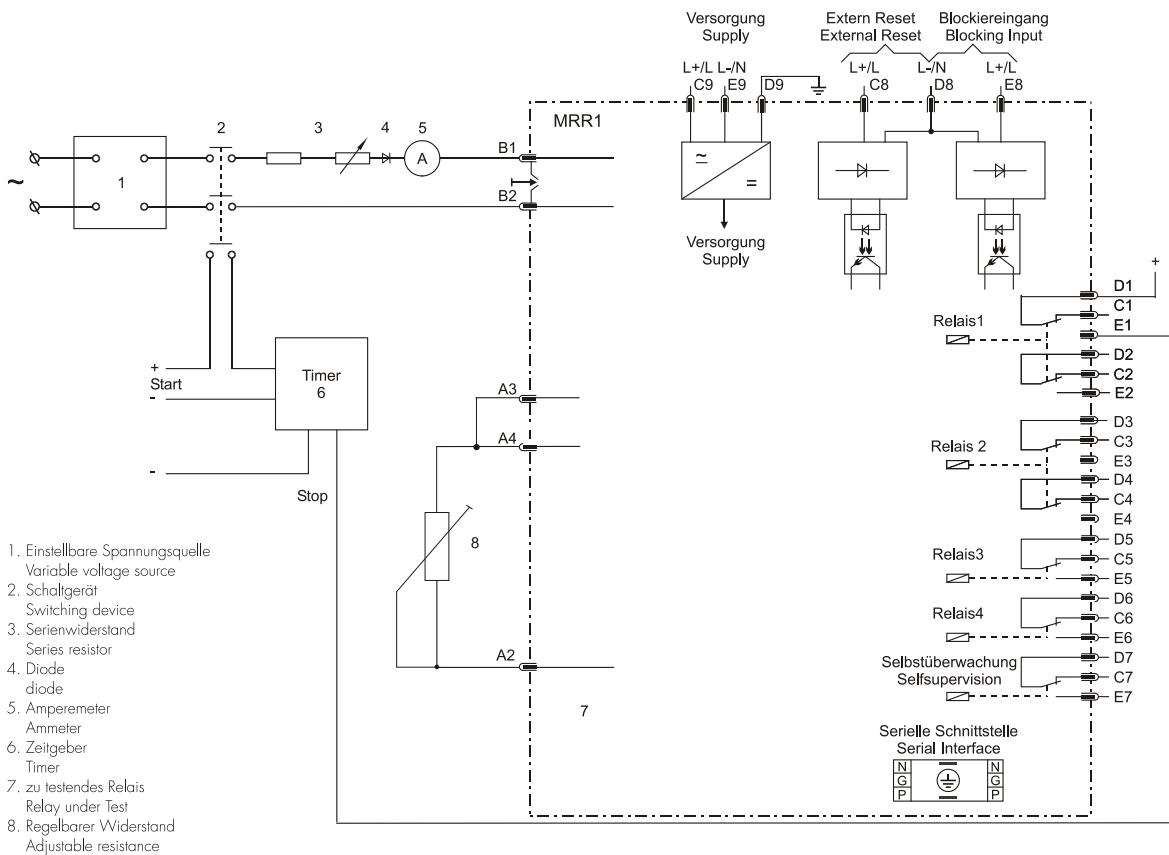

Figure 6.1: Test circuit

### 6.4.3 Checking the insulation measuring circuit

For checking the insulation measuring circuit a resistor with a defined value is simply connected to terminals A2 - A3/A4 (A3 and A4 are to be bridged). By pressing push button <SELECT/RESET>, measuring value R is displayed. This value must be identical with the de-fined value.

### 6.4.4 Checking the excitation current circuit

For checking the measuring values a current must be injected (terminals B1 - B2) which is below the set pickup current of the MRR1. After renewed pressing the <SELECT/RESET> push button, measuring value  $I_e$  is displayed and can be checked by using an ammeter.

Example : For this test circuit the dc current is generated from a single-pulse rectification. If a current of  $I_{AV} = 5A$  is fed to the MRR1, this value has to be indicated at the display. By repeatedly pressing the <SELECT/RESET> push button, measuring value  $I_r$  is displayed. Due to the conversion factor for single-pulse rectification of 0.318, the peak value at an average of  $I_{AV} = 5A$  comes to 15.73A. The ripple is calculated by using the following formula :

$$I_r \% = \frac{I_{e, max} - I_{e, min}}{I_e} \cdot 100\%$$

The measuring value  $I_r$  resulting from this is 314 %.

### 6.4.5 Checking the pickup value and reset value

For testing these values a current smaller than the adjusted pickup value has to be injected (terminals B1 - B2). The current is now to be increased until the relay picks up, which is indicated by lighting up of LEDs  $le$  and  $le>$ . At the same time the output relay selected by the parameter setting mode (see chapter 5.3.2) trips. The value shown at the ammeter must not vary more than 2 % from the adjusted pickup value of the MRR1. The resetting value is ascertained by slowly decreasing the test current until the output relay re-releases. Check that the resetting current is 0.98 times smaller than the operating current. This method is also to be used for the insulation measuring circuit.

### 6.4.6 Checking the tripping delay

For checking the tripping delay a timer is to be connected to the trip output relay contact. The timer should be started simultaneously with the test current injection in the current input circuit and stopped at the instant the relay trips. The test current should be 1.5 times the operating current. The tripping delay measured by the timer should not vary more than 3 % or less than 150ms from the adjusted tripping delay.

For checking the insulation measuring circuit the same method can be used. The permissible tolerance for this is 3 % or less than 1s from the adjusted tripping delay.

## 6.5 Real injection test

Generally, a test with real exciter current could be carried out in the similar manner as the injection test with current sources above described. Since the cost and potential hazards are very high for such a test, especially if staged fault tests are intended, these tests are usually limited to very important protective relays in the power system.

Because of its powerful combined indicating and measuring functions, you have still the possibilities to test the MRR1 relay in the manner of a primary injection without extra expenditures and time consumption.

In actual service, for example, the measured current values may be compared with the ammeter on the switch-board panel to verify that the relay works and measures correctly.

## 6.6 Maintenance

Maintenance testing is generally done on site at regular intervals. These intervals vary among users depending on many factors: e.g. the type of protective relays employed; the importance of the primary equipment being protected; the user's past experience with the relay, etc.

For electromechanical or static relays, maintenance testing will be performed at least once a year according to the experiences. For digital relays like MRR1, this interval can be substantially longer. This is because:

- The MR-relays are equipped with very wide self-supervision functions, so that many faults in the relay can be detected and signaled during service. Important: The self-supervision output relay must be connected to a central alarm panel!
- The combined measuring functions of MR-relays enable supervision the relay functions during service.
- The combined TRIP test function of the MR-relay allows to test the relay output circuits.

A testing interval of two years for maintenance will, therefore, be recommended.

During a maintenance test, the relay functions including the operating values and relay tripping times should be tested.

## 7. Technical data

---

### 7.1 Measuring input circuits

|                                  |                              |
|----------------------------------|------------------------------|
| Insulation resistance measuring: |                              |
| Measuring aux. voltage UH:       | ±24 V                        |
| Measuring frequency:             | $f_H = 0.51 \text{ Hz}$      |
| Measuring resistance range:      | 1 k $\Omega$ to 1 M $\Omega$ |
| Max. input voltage:              | 600 V DC                     |

#### Exciter DC current measuring

|                                       |   |
|---------------------------------------|---|
| Max. continuous current:              | 20 A DC                                 |
| Nominal current I <sub>N</sub>        | 10 A DC (measuring range: up to 25A DC) |
| Power consumption in current circuit: | <1 VA                                   |

### 7.2 Common data

|                         |            |
|-------------------------|------------|
| Dropout to pickup ratio | >98%       |
| Returning time:         | ≤30ms      |
| Minimum operating time: | ≤100ms     |
| Weight:                 | ca. 1.5 kg |
| Mounting position:      | any        |

#### Influences:

|   |       |
|---|-------|
| Temperature influence at<br>-20°C up to 70°C: | ±2.5% |
| Auxiliary voltage:                            | none  |

### 7.3 System data and test specifications

Insulation test voltage as per EN60255-6  
Voltage test as per IEC255-5  
2 KV DC for the terminals A2/A3/A4 for earth (C9)

## 7.4 Setting ranges and steps

| Function  | Parameter           | Setting ranges          | Steps                         | Tolerance                      |
|---|---------------------|-------------------------|-------------------------------|--------------------------------|
| Pickup value of insulation resistance supervision (warning) | R <sub>W</sub>      | 20 kΩ...200 kΩ / (EXIT) | 20...50: 1,0<br>50...100: 2,0 | < ±5% of setting value         |
| Tripping delay for R<                                       | t <sub>RW</sub>     | 1...50 sec / (EXIT)     | 0.1; 0.2; 0.5; 1.0            | ±3% or +0...2.2 s              |
| Pickup value of insulation resistance supervision (trip)    | R<                  | 2 kΩ...20 kΩ / (EXIT)   | 0.2; 0.5; 1.0                 | < ±5% of setting value         |
| Tripping delay for R<<                                      | t <sub>R&lt;</sub>  | 1...50 sec / (EXIT)     | 0.1; 0.2; 0.5; 1.0            | ±3% or +0...2.2 s              |
| Pickup value of exciter undercurrent element                | I <sub>e&lt;</sub>  | (EXIT) / 0,2...20 A     | 0.05; 0.1; 0.2; 0.5           | ±2% of setting value or ±0,01A |
| Tripping delay for I<                                       | t <sub>Ie&lt;</sub> | 0.1...10 sec / (EXIT)   | 0.05; 0.1; 0.2                | ±3% or ±150 ms                 |
| Pickup value of exciter overcurrent element                 | I <sub>e&gt;</sub>  | 0,2...20 A / (EXIT)     | 0.05                          | ±2% of setting value or ±0,01A |
| Tripping delay for I>                                       | t <sub>Ie&gt;</sub> | 0.1...10 sec / (EXIT)   | 0.05; 0.1; 0.2                | ±3% or ±150 ms                 |
| Pickup value of "ripple component"                          | I <sub>r</sub>      | 10...400 % (EXIT)       | 2                             | ±5% of setting value           |
| Tripping delay for IR                                       | t <sub>Ir</sub>     | 0.1...10 sec / (EXIT)   | 0.05; 0.1; 0.2                | ±3% or ±150 ms                 |
| Slave address RS485   | RS                  | 1...32                  | 1                             | -                              |

Table 7.1: Setting ranges and steps

## 7.5 Order Form

|                                |                     |   |
|--------------------------------|---------------------|---|
| <b>Rotor earth fault relay</b> | <b><i>MRR1-</i></b> |   |
| Housing (12TE) 19"-rack        |                     | A |
| Flush mounting                 |                     | D |

Technical data subject to change without notice!

## Setting-list MRR1

Project: \_\_\_\_\_ Job.-no.: \_\_\_\_\_

Function group: = \_\_\_\_\_ Location: + \_\_\_\_\_ Relay code: - \_\_\_\_\_

Relay functions: \_\_\_\_\_ Password: \_\_\_\_\_

| Function                   |   | Unit | Default settings | Actual settings |
|----------------------------|---|------|------------------|-----------------|
| R <sub>W</sub>             | Pickup value of insulation resistance supervision (warning) | kΩ   | 80.0             |                 |
| t <sub>RW</sub>            | Tripping delay for R<                                       | s    | 1.00             |                 |
| R<                         | Pickup value of insulation resistance supervision (trip)    | kΩ   | 20.0             |                 |
| t <sub>R&lt;</sub>         | Tripping delay for R<<                                      | s    | 1.00             |                 |
| I <sub>e&lt;</sub>         | Pickup value exciter undercurrent element                   | A    | 0.50             |                 |
| t <sub>Ie&lt;</sub>        | Tripping delay for I<                                       | s    | 0.10             |                 |
| I <sub>e&gt;</sub>         | Pickup value exciter over current element                   | A    | 5.00             |                 |
| t <sub>Ie&gt;</sub>        | Tripping delay for I>                                       | s    | 0.1              |                 |
| I <sub>r</sub>             | Pickup value for ripple voltage supervision                 | %    | 50               |                 |
| t <sub>I<sub>r</sub></sub> | Tripping delay for t <sub>I<sub>r</sub></sub>               | s    | 0.1              |                 |
| RS                         | Slave address of the serial interface                       |      | 1                |                 |

### Blocked function and relay assignment:

| Function           | Blocking via D8/E8 | Relay assignment | Relay assignment |   |   |   |
|--------------------|--------------------|------------------|------------------|---|---|---|
|                    |                    |                  | 1                | 2 | 3 | 4 |
| R <sub>W</sub>     | ①                  | Pickup           |                  |   |   |   |
|                    |                    | Tripping         |                  | ① |   |   |
| R<                 | ①                  | Pickup           |                  |   |   |   |
|                    |                    | Tripping         | ①                |   |   |   |
| I <sub>e&lt;</sub> | ①                  | Pickup           |                  |   |   |   |
|                    |                    | Tripping         |                  |   | ① |   |
| I <sub>e&gt;</sub> | ①                  | Pickup           |                  |   |   |   |
|                    |                    | Tripping         |                  |   | ① |   |
| I <sub>r</sub>     | ①                  | Pickup           |                  |   |   |   |
|                    |                    | Tripping         |                  |   |   | ① |

### Code jumper:

|     | J1 | J2 | J3 |
|-----|----|----|----|
| On  |    | ②  |    |
| Off | ①  | ②  | ①  |

Default settings are marked with ①.

② The Code jumper J2 has no function.

Please mark your settings if they are different from default settings.

# HighTECH Line

<https://docs.SEGelectronics.de/mrr1>  
<https://docs.SEGelectronics.de/mr>

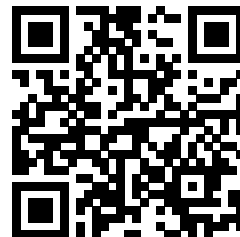
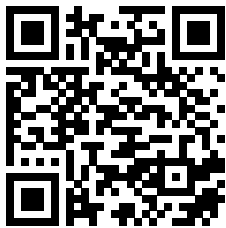

SEG Electronics GmbH reserves the right to update any portion of this publication at any time. Information provided by SEG Electronics GmbH is believed to be correct and reliable. However, SEG Electronics GmbH assumes no responsibility unless otherwise expressly undertaken.



SEG Electronics GmbH  
Krefelder Weg 47 • D-47906 Kempen (Germany)  
Postfach 10 07 55 (P.O.Box) • D-47884 Kempen (Germany)  
Telephone: +49 (0) 21 52 145 1

Internet: [www.SEGelectronics.de](http://www.SEGelectronics.de)

Sales  
Telephone: +49 (0) 21 52 145 331  
Fax: +49 (0) 21 52 145 354  
E-mail: [info@SEGelectronics.de](mailto:info@SEGelectronics.de)

Service  
Telephone: +49 (0) 21 52 145 614  
Fax: +49 (0) 21 52 145 354  
E-mail: [info@SEGelectronics.de](mailto:info@SEGelectronics.de)

SEG Electronics has company-owned plants, subsidiaries, and branches, as well as authorized distributors and other authorized service and sales facilities throughout the world.

Complete address / phone / fax / email information for all locations is available on our website.