

# MANUAL

HighTECH Line | PROTECTION TECHNOLOGY  
MADE SIMPLE

MRN3 | MAINS DECOUPLING RELAY



## MAINS DECOUPLING RELAY

Original document

English

Revision: C

**SEG Electronics reserves the right to update any portion of this publication at any time.  
Information provided by SEG Electronics is believed to be correct and reliable.  
However, no responsibility is assumed by SEG Electronics unless otherwise expressly undertaken.**

**© SEG Electronics 1994–2020. All rights reserved.**

## Contents

<b>1.</b>	<b>Introduction and application</b>	<b>5</b>
<b>2.</b>	<b>Features and characteristics</b>	<b>6</b>
<b>3.</b>	<b>Design</b>	<b>7</b>
3.1	Connections	7
3.1.1	Analog input circuits	7
3.1.2	Blocking input	7
3.1.3	Reset input	7
3.1.4	Output relays	8
3.1.5	Fault recorder	8
3.2	Parameter settings	10
3.3	LEDs	11
3.4	Front plate	12
<b>4.</b>	<b>Working principle</b>	<b>13</b>
4.1	Analog circuits	13
4.2	Digital circuits	13
4.3	Voltage supervision	13
4.3.1	Selection of star or delta connection	14
4.4	Principle of frequency supervision	15
4.5	Measuring of frequency gradient (MRN3-2)	15
4.6	Vector surge supervision (MRN3-1)	16
4.6.1	Measuring principle of vector surge supervision	17
4.7	Voltage threshold value for frequency measuring	21
4.8	Blocking function	21
<b>5.</b>	<b>Operation and setting</b>	<b>22</b>
5.1	Display	22
5.2	Setting procedure	23
5.3	System parameter	24
5.3.1	Display of residual voltage $U_E$ as primary quantity ( $U_{prim}/U_{sec}$ )	24
5.3.2	Y – Switch over	24
5.3.3	Setting of nominal frequency	24
5.3.4	Display of the activation storage (FLSH/NOFL)	25
5.3.5	Parameter switch/external trigger for the fault recorder	25
5.4	Protection parameters	27
5.4.1	Parameter setting of over- and under voltage supervision	27
5.4.2	Number of measuring repetitions (T) for frequency functions	27
5.4.3	Threshold of frequency supervision	27
5.4.4	Tripping delays for the frequency elements	28
5.4.5	Parameter setting of vector surge supervision (MRN3-1)	28
5.4.6	Parameter setting of frequency gradient (MRN3-2)	30
5.4.7	Settable voltage threshold ( $df/dt$ at MRN3-2)	30
5.4.8	Adjustment of the slave address	30
5.4.9	Setting of Baud-rate (applies for Modbus Protocol only)	30
5.4.10	Setting of parity (applies for Modbus Protocol only)	30
5.5	Adjustment of the fault recorder	31
5.5.1	Number of the fault recordings	31
5.5.2	Adjustment of trigger occurrences	31
5.5.3	Pre-trigger time ( $T_{pre}$ )	31
5.6	Adjustment of the clock	31
5.7	Additional functions	32
5.7.1	Setting procedure for blocking the protection functions	32
5.8	Indication of measuring values	34
5.8.1	Measuring indication	34
5.8.2	Min./Max.- values	34
5.8.3	Unit of the measuring values displayed	35
5.8.4	Indication of fault data	35
5.9	Fault memory	35
5.9.1	Reset	36

---

5.9.2	Erasure of fault storage .....	36
<b>6.</b>	<b>Relay testing and commissioning .....</b>	<b>37</b>
6.1	Power-On.....	37
6.2	Testing the output relays .....	37
6.3	Checking the set values.....	38
6.4	Secondary injection test.....	38
6.4.1	Test equipment .....	38
6.5	Example of test circuit.....	39
6.5.1	Checking the input circuits and measuring functions .....	40
6.5.2	Checking the operating and resetting values of the over/under voltage functions .....	40
6.5.3	Checking the relay operating time of the over/undervoltage functions .....	40
6.5.4	Checking the operating and resetting values of the over/under frequency functions .....	41
6.5.5	Checking the relay operating time of the over/underfrequency functions .....	41
6.5.6	Checking the vector surge function .....	41
6.5.7	Checking the external blocking and reset functions .....	42
6.6	Primary injection test .....	43
6.7	Maintenance .....	43
<b>7.</b>	<b>Technical data .....</b>	<b>44</b>
7.1	Measuring input circuits .....	44
7.2	Common data .....	44
7.3	Setting ranges and steps .....	45
7.3.1	Interface parameter .....	46
7.3.2	Parameters for the fault recorder.....	46
7.4	Output relays .....	46
<b>8.</b>	<b>Order form .....</b>	<b>47</b>

# 1. Introduction and application

---

The MRN3 is a universal mains decoupling device and covers the protection requirements from VDEW and most other utilities for the mains parallel operation of power stations.

- Over/ and under voltage protection,
- over/ and under frequency protection,
- extremely fast decoupling of generator in case of mains failure (MRN3-1) or
- rate of change of frequency  $df/dt$  (MRN3-2)

Because of combination of three protection functions in one device the MRN3 is a very compact mains decoupling device. Compared to the standard used single devices it has a very good price/performance ratio.

For applications where the single protection functions are required SEG Electronics GmbH can offer the single MR-relays as follows:

- MRU3-1 four step independent over-/ and under voltage protection (also used for generator earth fault protection).
- MRU3-2 two step independent over-/ and under-voltage protection with evaluation of the symmetrical voltage components.
- MRF3 four step independent over/ and under- frequency protection and two step frequency gradient supervision  $df/dt$ .
- MRG2 generator mains monitor / vector surge detection.

## 2. Features and characteristics

---

- Microprocessor technology with watchdog,
- effective analog low pass filter for suppressing harmonics when measuring frequency and vector surge,
- digital filtering of the measured values by using discrete Fourier analysis to suppress higher harmonics and d.c. components induced by faults or system operations,
- integrated functions for voltage, frequency and vector surge in one device as well as single voltage, frequency and vector surge devices,
- two parameter sets,
- voltage supervision each with two step under-/and overvoltage detection,
- frequency supervision with three step under-/or over frequency (user setting),
- completely independent time settings for voltage and frequency supervision,
- adjustable voltage threshold value for blocking frequency and vector surge measuring,
- display of all measuring values and setting parameters for normal operation as well as tripping via a alphanumeric display and LEDs,
- display of measuring values as primary quantities
- Storage of trip values and switching-off time ( $t_{CBFP}$ ) of 5 fault occurrences (fail-safe of voltage),
- recording of up to eight fault occurrences with time stamp
- for blocking the individual functions by the external blocking input, parameters can be set according to requirement,
- user configurable vector surge measurement 1-of-3 or 3-of-3,
- reliable vector surge measuring by exact calculation algorithm,
- suppression of indication after an activation (LED flash),
- free assignment for output relays,
- display of date and time,
- in compliance with VDE 0435, part 303 and IEC 255,
- serial data exchange via RS485 interface possible; alternatively with RS485 Pro-Open Data Protocol or Modbus Protocol.

**Important:**

For additional common data of all MR-relays please refer to technical description "MR - Digital Multifunctional Relays".

## 3. Design

### 3.1 Connections

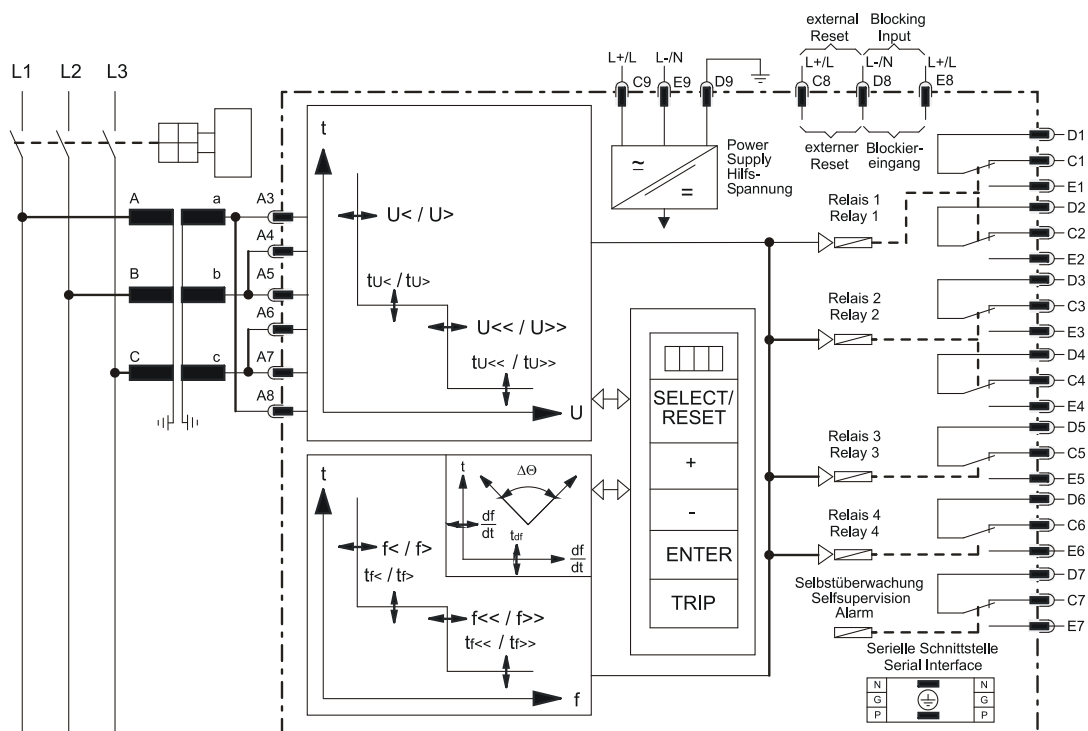

Figure 3.1: Connection diagram MRN3-1 and MRN3-2

#### 3.1.1 Analog input circuits

The analog input voltages are galvanically decoupled by the input transformers of the device, then filtered and finally fed to the analog digital converter. The measuring circuits can be applied in star or delta connection (refer to chapter 4.3.1).

#### 3.1.2 Blocking input

The blocking function can be set according to requirement. By applying the auxiliary voltage to D8/E8, the previously set relay functions are blocked (refer to 4.8 and 5.7.1).

#### 3.1.3 Reset input

Please refer to chapter 5.9.1.

### 3.1.4 Output relays

The MRN3 is equipped with 5 output relays. Apart from the relay for self-supervision, all protective functions can be optionally assigned:

- Relay 1: C1, D1, E1 and C2, D2, E2
- Relay 2: C3, D3, E3 and C4, D4, E4
- Relay 3: C5, D5, E5
- Relay 4: C6, D6, E6
- Relay 5: Signal self-supervision (internal failure of the unit) C7, D7, E7

All trip and alarm relays are working current relays, the relay for self supervision is an idle current relay.

### 3.1.5 Fault recorder

The MRN3 has a fault value recorder which records the measured analog values as instantaneous values.

The instantaneous values

UL1; UL2; UL3 for star connection  
or U12; U23; U21 for delta connection

are scanned at a raster of 1.25 ms (at 50 Hz) and 1.041 ms (at 60 Hz) and saved in a cyclic buffer. It is possible to store 1 - 8 fault occurrences with a total recording time of 16 s (with 50 Hz) and 13.33 s (with 60 Hz) per channel.

#### Storage division

Independent of the recording time, the entire storage capacity can be divided into several cases of disturbance with a shorter recording time each. In addition, the deletion behavior of the fault recorder can be influenced.

#### No writing over

If 2, 4 or 8 recordings are chosen, the complete memory is divided into the relevant number of partial segments. If this max. number of fault event has been exceeded, the fault recorder block any further recordings in order to prevent that the stored data are written over. After the data have been read and deleted, the recorder to ready again for further action.

#### Writing over

If 1, 3 or 7 recordings are chosen, the relevant number of partial segments is reserved in the complete memory. If the memory is full, a new recording will always write over the oldest one.



The memory part of the fault recorder is designed as circulating storage. In this example 7 fault records can be stored (written over).

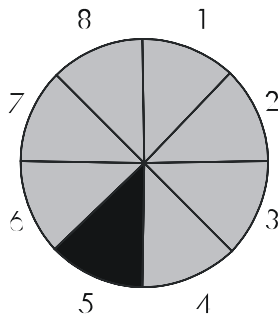

Figure 3.2: Division of the memory into 8 segments, for example

Memory space 6 to 4 is occupied.  
Memory space 5 is currently being written in

Since memory spaces 6, 7 and 8 are occupied, this example shows that the memory has been assigned more than eight recordings. This means that No. 6 is the oldest fault recording and No. 4 the most recent one.

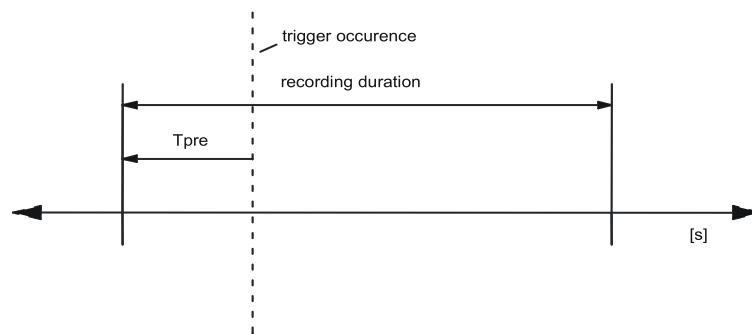

Figure 3.3: Basic set-up of the fault recorder

Each memory segment has a specified storage time which permits setting of a time prior to the trigger event.

Via the interface RS485 the data can be read and processed by means of a PC (HTL/PL-Soft4). The data is graphically edited and displayed. Binary tracks are recorded as well, e.g. activation and trip.

## 3.2 Parameter settings

### System parameters

Parameter settings	MRN3-1	MRN3-2
$U_{\text{prim}}/U_{\text{sek}}$	X	X
$\Delta/Y$	X	X
fN	X	X
P2/FR	X	X
LED-Flash	X	X

Table 3.1: System parameters

### Protection parameters

Setting parameter	MRN3-1	MRN3-2
$U_{<}$	X	X
$t_{U_{<}}$	X	X
$U_{<<}$	X	X
$t_{U_{<<}}$	X	X
$U_{>}$	X	X
$t_{U_{>}}$	X	X
$U_{>>}$	X	X
$t_{U_{>>}}$	X	X
T	X	X
$f_1$	X	X
$t_{r1}$	X	X
$f_2$	X	X
$t_{r2}$	X	X
$f_3$	X	X
$t_{r3}$	X	X
df		X
dt		X
1/3	X	
$\Delta\theta$	X	
$U_{B<}$	X	X
RS485/Slave	X	X
Baud-Rate*	X	X
Parity-Check*	X	X

Table 3.2: Protection parameters \*only Modbus

### Blocking functions

Parameter settings	MRN3-1	MRN3-2
$U_{<}$	X	X
$U_{<<}$	X	X
$U_{>}$	X	X
$U_{>>}$	X	X
$f_1$	X	X
$f_2$	X	X
$f_3$	X	X
$\Delta\theta$	X	
df/dt		X

Table 3.3: Blocking functions

### Parameters for the fault recorder

Parameter setting	MRN3-1	MRN3-2
Number of fault events	X	X
Trigger events	X	X
Pre-Triggerzeit $T_{pre}$	X	X

Table 3.4: Parameters for the fault recorder

### Additional functions

Parameter settings	MRN3-1	MRN3-2
Ralay assignment	X	X
Fault recorder	X	X

Table 3.5: Additional functions

### Date and time

Parameter settings	MRN3-1	MRN3-2
Year Y = 99	X	X
Month M = 03	X	X
Day D = 16	X	X
hour h = 07	X	X
minute m = 29	X	X
second s = 56	X	X

Table 3.6: Date and time

The window for parameter setting is located behind the measured value display. The parameter window can be accessed via the <SELECT/RESET> key.

## 3.3 LEDs

All LEDs (except LED RS, min. and max.) are two colored. The LEDs on the left side, next to the alphanumerical display light up green during measuring and red after tripping.

The LEDs below the push button <SELECT/RESET> are lit green during setting and inquiry procedure of the setting values which are printed on the left side next to the LEDs. The LEDs will light up red after parameterizing of the setting values next to their right side.

The LED marked with letters RS lights up during setting of the slave address of the device for serial data communication.

The LED marked with the letters FR is alight while the fault recorder is being adjusted.

### 3.4 Front plate

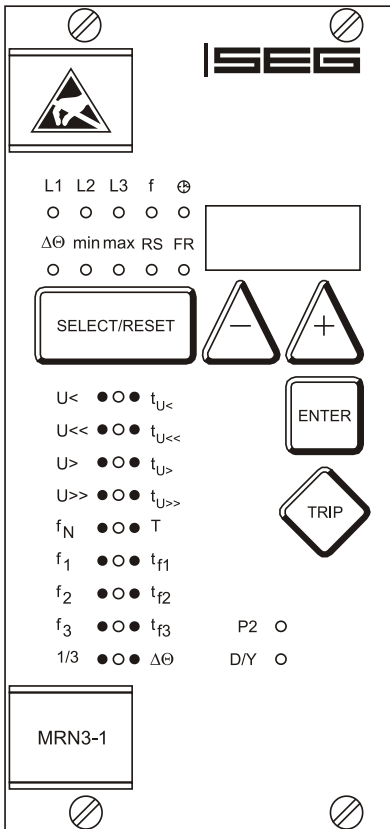

Figure 3.4: Front plate MRN3-1

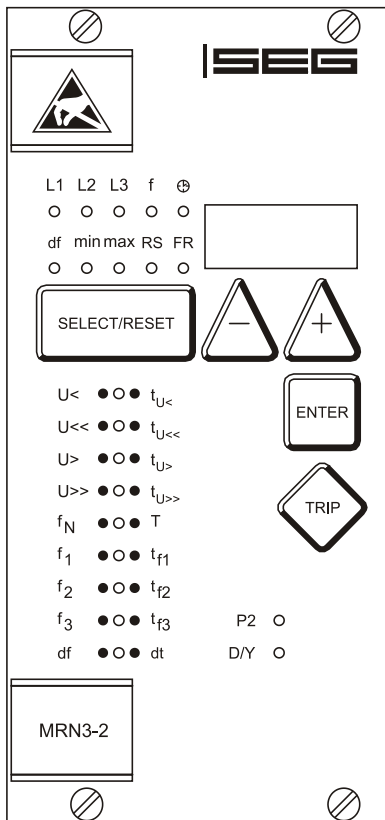

Figure 3.5: Front plate MRN3-2

## 4. Working principle

---

### 4.1 Analog circuits

The input voltages are galvanically insulated by the input transformers. The noise signals caused by inductive and capacitive coupling are suppressed by an analog R-C filter circuit.

The analog voltage signals are fed to the A/D-converter of the microprocessor and transformed to digital signals through Sample- and Hold- circuits. The analog signals are sampled with a sampling frequency of  $16 \times f_N$ , namely, a sampling rate of 1.25 ms for every measuring quantity, at 50 Hz.

### 4.2 Digital circuits

The essential part of the MRN3 relay is a powerful microcontroller. All of the operations, from the analog digital conversion to the relay trip decision, are carried out by the microcontroller digitally. The relay program is located in an EPROM (Electrically-Programmable-Read-Only-Memory). With this program the CPU of the microcontroller calculates the three phase voltage in order to detect a possible fault situation in the protected object.

For the calculation of the voltage value an efficient digital filter based on the Fourier Transformation (DFFT - Discrete Fast Fourier Transformation) is applied to suppress high frequency harmonics and d.c. components caused by fault-induced transients or other system disturbances.

The micro-processor continuously compares the measured values with the preset thresholds stored in the parameter memory (EEPROM). If a fault occurs an alarm is given and after the set tripping delay has elapsed, the corresponding trip relay is activated.

The relay setting values for all parameters are stored in a parameter memory (EEPROM – Electrically Erasable Programmable Read Only Memory), so that the actual relay settings cannot be lost, even if the power supply is interrupted.

The microprocessor is supervised by a built-in "watchdog" timer. In case of a failure the watchdog timer resets the microprocessor and gives an alarm signal via the output relay "self supervision".

### 4.3 Voltage supervision

The voltage element of MRN3 has the application in protection of generators, consumers and other electrical equipment against over-/and under voltage.

The relay is equipped with a two step independent three-phase overvoltage ( $U>$ ,  $U>>$ ) and under voltage ( $U<$ ,  $U<<$ ) function with completely separate time and voltage settings.

In delta connection the phase-to-phase voltages and in star connection the phase-to-neutral voltages are continuously compared with the preset thresholds.

For the overvoltage supervision the highest, for the under voltage supervision of the lowest voltage of the three phases are decisive for energizing.

### 4.3.1 Selection of star or delta connection

All connections of the input voltage transformers are led to screw terminals. The nominal voltage of the device is equal to the nominal voltage of the input transformers. Dependent on the application the input transformers can be connected in either delta or star. The connection for the phase-to-phase voltage is the delta connection. In star connection the measuring voltage is reduced by  $1/\sqrt{3}$ . During parameter setting the connection configuration either Y or  $\Delta$  has to be adjusted.

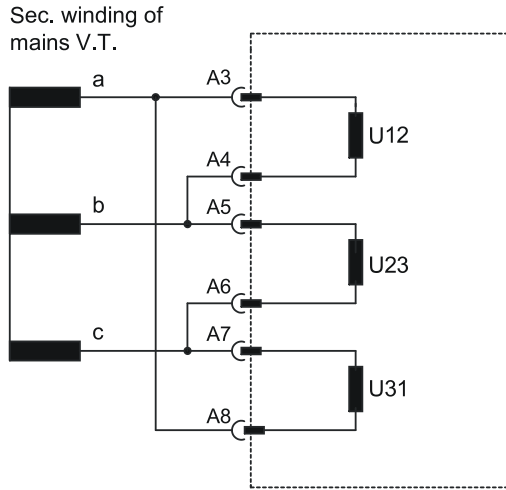

Figure 4.1: Input v.t.s in delta connection ( $\Delta$ )

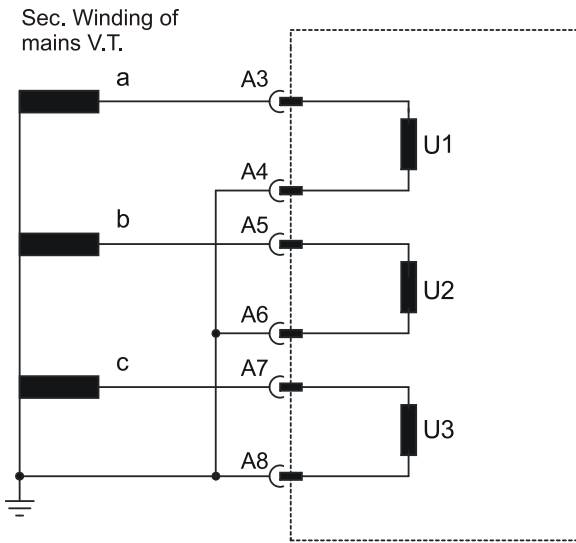

Figure 4.2: Input v.t.s in star connection (Y)

## 4.4 Principle of frequency supervision

The frequency element of MRN3 protects electrical generators, consumers or electrical operating equipment in general against over- or under frequency.

The relay has independent three frequency elements  $f_1 - f_3$  with a free choice of parameters, with separate adjustable pickup values and delay times.

The measuring principle of the frequency supervision is based in general on the time measurement of complete cycles, whereby a new measurement is started at each voltage zero passage. The influence of harmonics on the measuring result is thus minimized.

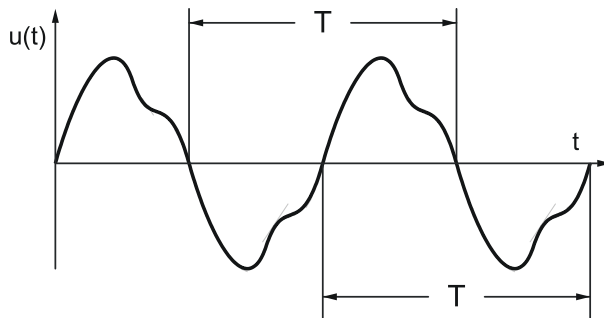

Figure 4.3: Determination of cycle duration by means of zero passages.

In order to avoid false tripping during occurrence of interference voltages and phase shifts the relay works with an adjustable measuring repetition. (refer to chapter 5.4.2)

Frequency tripping is sometimes not desired by low measured voltages which for instance occur during alternator acceleration. All frequency supervision functions can be blocked with the aid of an adjustable voltage threshold  $U_B$  in case the measured voltages value is below this value.

## 4.5 Measuring of frequency gradient (MRN3-2)

Electrical generators running in parallel with the mains, e.g. industrial internal power supply plants, should be separated from the mains when failure in the intra system occurs for the following reasons:

- It must be prevented that the electrical generators are damaged when mains voltage recovering asynchronous, e.g. after a short interruption.
- The industrial internal power supply must be maintained.

A reliable criterion of detecting mains failure is the measurement of the rate of change of frequency  $df/dt$ . Precondition for this is a load flow via the mains coupling point. At mains failure the load flow changing then spontaneously leads to an increasing or decreasing frequency. At active power deficit of the internal power station a linear drop of the frequency occurs and a linear increase occurs at power excess. Typical frequency gradients during application of "mains decoupling" are in the range of 0.5 Hz/s up to over 2 Hz/s. The MRN3 detects the instantaneous frequency gradient  $df/dt$  of each mains voltage period in an interval of one half period each. Through multiple evaluation of the frequency gradient in sequence the continuity of the directional change (sign of the frequency gradient) is determined. Because of this special measuring procedure a high safety in tripping and thus a high stability against transient processes, e.g. switching procedure are reached. The total switching off time at mains failure is between 60 ms and 80 ms depending on the set-ting.

## 4.6 Vector surge supervision (MRN3-1)

The vector surge supervision protects synchronous generators in mains parallel operation due to very fast decoupling in case of mains failure. Very dangerous are mains auto reclosings for synchronous generators. The mains voltage returning after 300 ms can hit the generator in asynchronous position. A very fast decoupling is also necessary in case of long time mains failures. Generally there are two different applications:

- a) Only mains parallel operation no single operation: In this application the vector surge supervision protects the generator by tripping the generator circuit breaker in case of mains failure.
- b) Mains parallel operation and single operation: For this application the vector surge supervision trips the mains circuit breaker. Here it is insured that the gen.-set is not blocked when it is required as the emergency set.

A very fast decoupling in case of mains failures for synchronous generators is known as very difficult. Voltage supervision units cannot be used because the synchronous alternator as well as the consumer impedance support the decreasing voltage.

For this the mains voltage drops only after some

100 ms below the pickup threshold of voltage supervision relays and therefore a safe detection of mains auto reclosing is not possible with this kind of relay.

Frequency relays are partial unsuitable because only a highly loaded generator decreases its speed within 100 ms. Current relays detect a fault only when short-circuit type currents exist, but cannot avoid their development. Power relays are able to pickup within 200 ms, but they cannot prevent power to rise to short-circuit values too. Since power changes are also caused by sudden loaded alternators, the use of power relays can be problematic.

Whereas the MRN3-1 detects mains failures within 60 ms without the restrictions described above because they are specially designed for applications where very fast decoupling from the mains is required.

Adding the operating time of a circuit breaker or contactor, the total disconnection time remains below 150 ms. Basic requirement for tripping of the generator/mains monitor is a change in load of more than 15 - 20% of the rated load. Slow changes of the system frequency, for instance at regulating processes (adjustment of speed regulator) do not cause the relay to trip.

Trippings can also be caused by short-circuits within the grid, because a voltage vector surge higher than the preset value can occur. The magnitude of the voltage vector surge depends on the distance between the short-circuit and the generator. This function is also of advantage to the Power Utility Company because the mains short-circuit capacity and consequently the energy feeding the short-circuit is limited.

To prevent a possible false tripping the vector surge measuring can be blocked at a set low input voltage (refer to 5.4.7). The under voltage lockout acts faster than the vector surge measurement.

Vector surge tripping is blocked by a phase loss so that a VT fault (e.g. faulty VTs fuse) does not cause false tripping. When switching on the aux. voltage or measuring voltage, the vector surge supervision is blocked for 5 s (refer to chapter 4.8).

### Note:

In order to avoid any adverse interference voltage effects, for instance from contactors or relays, which may cause over functions, MRN3-1 should be connected separately to the busbar.



### 4.6.1 Measuring principle of vector surge supervision

When a synchronous generator is loaded, a rotor displacement angle is built between the terminal voltage (mains voltage  $U_1$ ) and the synchronous internal voltage ( $U_p$ ). Therefore a voltage is difference  $\Delta U$  is built between  $U_p$  and  $U_1$  (Fig. 4.4).

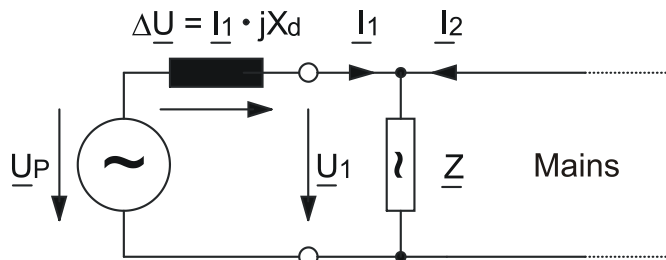

Figure 4.4: Equivalent circuit at synchronous generator in parallel with the mains

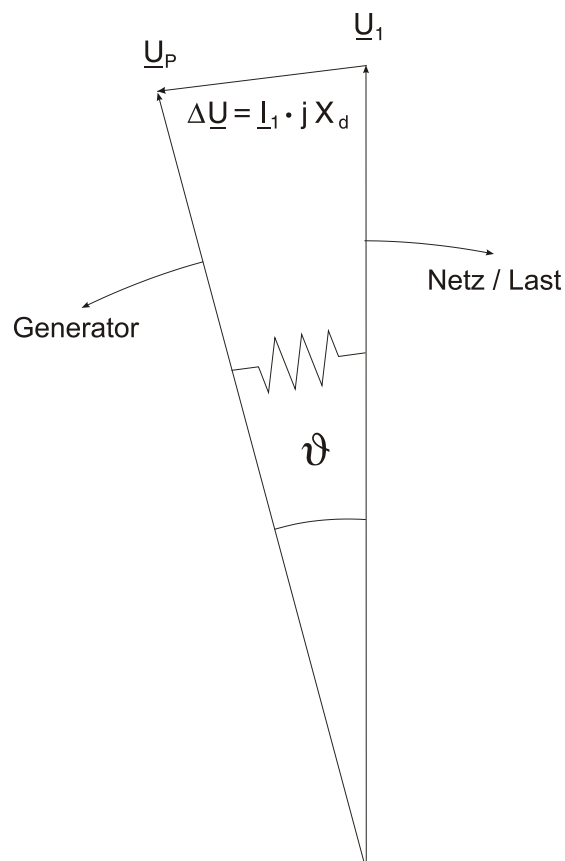

Figure 4.5: Voltage vectors at mains parallel operation

The rotor displacement angle  $\vartheta$  between stator and rotor is depending of the mechanical moving torque of the generator shaft. The mechanical shaft power is balanced with the electrical fielded mains power, and therefore the synchronous speed keeps constant (Fig. 4.5).

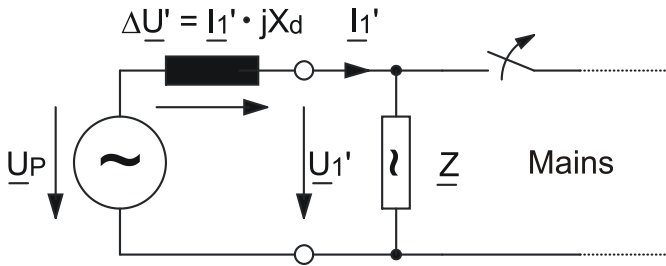

Figure 4.6: Voltage vectors at mains failure

In case of mains failure or auto reclosing the generator suddenly feeds a very high consumer load. The rotor displacement angle is decreased repeatedly and the voltage vector  $\underline{U}_1$  changes its direction ( $\underline{U}_1'$ ) (Fig. 4.6 and 4.7).

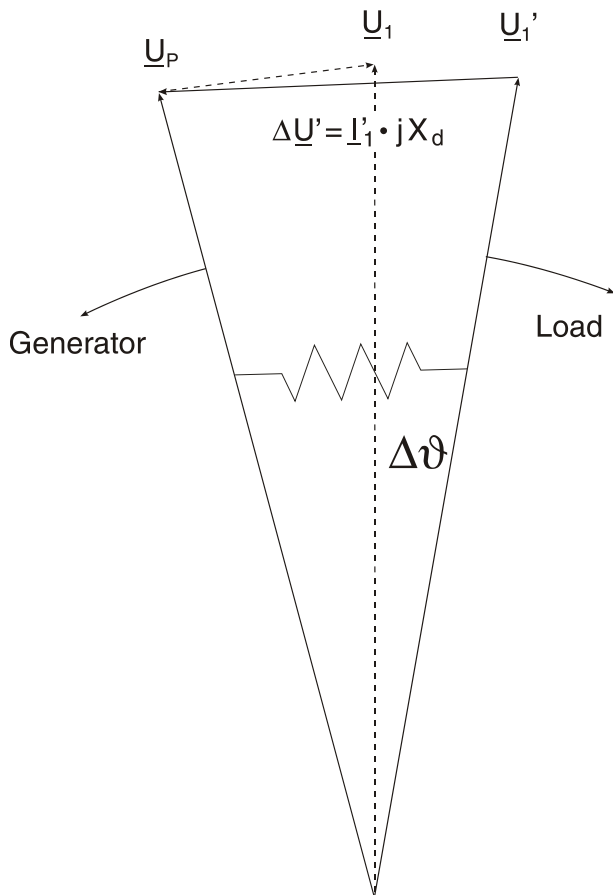

Figure 4.7: Equivalent circuit at mains failure

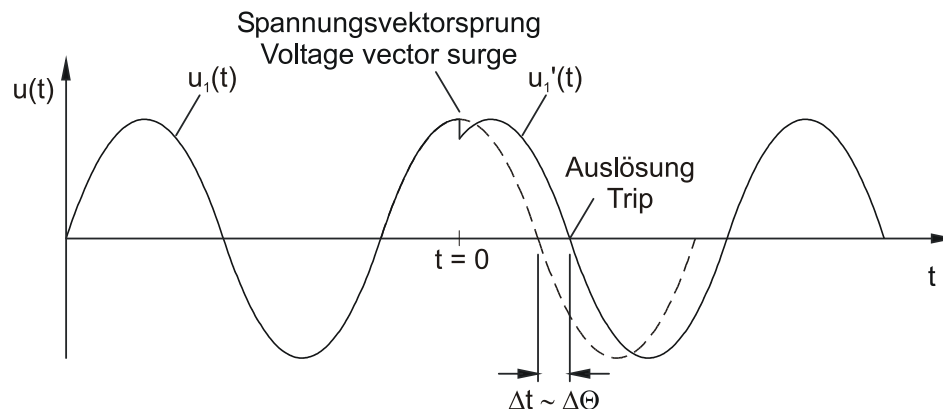

Figure 4.8: Voltage vector surge

As shown in the voltage/time diagram the instantaneous value of the voltage jumps to another value and the phase position changes. This is named phase or vector surge.

The MRN3-1 measures the cycle duration. A new measuring is started at each voltage zero passage. The measured cycle duration is internally compared with a quartz stable reference time and from this the deviation of the cycle duration of the voltage signal is ascertained. In case of a vector surge as shown in fig. 4.8, the zero passage occurs either earlier or later. The established deviation of the cycle duration is in compliance with the vector surge angle.

If the vector surge angle exceeds the set value, the relay trips immediately.

Tripping of the vector surge is blocked in case of loss of one or more phases of the measuring voltage.

#### Tripping logic for vector surge measurement:

The vector surge function of the MRN3-1 super-vises vector surges in all three phases at the same time. Tripping of the relay can be adjusted for an one phase vector surge (more sensitive measurement). For this the parameter 1/3 has to be set to "1Ph". When the parameter 1/3 is set to "3Ph", tripping of the vector surge element occurs only if the vector surge angle exceeds the set value in all three phases at the same time.

**Application hint**

Although the vector surge relay guarantees very fast and reliable detection of mains failures under nearly all operational conditions of mains parallel running alternators, the following borderline cases have to be considered accordingly:

**a) None or only insignificant change of power flow at the utility connection point during mains failures.**

This can occur during peak lopping operation or in CHP stations (Combined Heat and Power) where the power flow between power station and the public grid may be very low. For detection of a vector surge at parallel running alternators, the load change must be at least 15 - 20% of the rated power. If the active load at the utility connection point is regulated to a minimal value and a high resistance mains failure occurs, then there are no vector surge nor power and frequency changes and the mains failure is not detected.

This can only happen if the public grid is disconnected near the power station and so the alternators are not additionally loaded by any consumers. At distant mains failures the synchronous alternators are abruptly loaded by remaining consumers which leads directly to a vector surge and so mains failure detection is guaranteed.

If such a situation occurs the following has to be taken into account:

In case of an undetected mains failure, i.e. with the mains coupling C.B. closed, the vector surge relay reacts upon the first load change causing a vector surge and trips the mains C.B.

For detecting high resistance mains failures a minimum current relay with an adjustable trip delay can be used. A trip delay is needed to allow regulating actions where the current may reach "zero" at the utility connection point. At high resistance mains failures, the mains coupling C.B. is tripped by the minimum current relay after the time delay.

To prevent asynchronous switching on, an automatic reclosing of the public grid should be not possible during this time delay.

A further measure could be, that the load regulation at the utility connection point guarantees a minimum power flow of 15 - 20% of rated power.

**b) Short circuit type loading of the alternators at distant mains failures**

At any distant mains failure, the remaining consumers cause sudden short circuit type loading of the power station generators. The vector surge relay detects the mains failure in about 60 ms and switches off the mains coupling C.B. The total switch off time is about 100 - 150 ms. If the generators are provided with an extremely fast short circuit protection e.g. able to detect  $di/dt$ , the alternators might be switched off unselectively by the generator C.B., which is not desirable because the power supply for the station is endangered and later on synchronized changeover to the mains is only possible after manual reset of the overcurrent protection.

To avoid such a situation, the alternator C.B.s must have a delayed short circuit protection. The time delay must be long enough so that mains decoupling by the vector surge relay is guaranteed.

## 4.7 Voltage threshold value for frequency measuring

At low measuring voltages, e.g. during generator start-up, frequency and vector surge or  $df/dt$ -measuring is perhaps not desired.

By means of the adjustable voltage threshold value  $U_{B<}$ , functions  $f_1 - f_3$ ,  $df/dt$  or  $\Delta\Theta$  are blocked if the measured voltage falls below the set value.

## 4.8 Blocking function

No.	Dynamic Behaviour	$U_{<<}$	$U_{>>}$	$f_1, f_2, f_3$	$\Delta\Theta$	$df/dt$
1	voltage to external blocking input is applied	free programmable	free programmable	free programmable	free programmable	free programmable
2	blocking input is released	released instantaneously	released instantaneously	released after 1 s	released after 5 s	released after 5 s
3	supply voltage is switched on	blocked for 200 ms	blocked for 200 ms	blocked for 1 s	blocked for 1 s	blocked for 1 s
4	3ph measuring volt. is suddenly applied	released	released	blocked for 1 s	blocked for 5 s	blocked for 5 s
5	one or several measuring voltages are switched off suddenly (phase failure)	released	released	blocked	blocked	blocked
6	measuring voltage smaller $U_{B<}$ (adjustable voltage threshold value)	released	released	blocked	blocked	blocked

Table 4.1: Dynamic behaviour of MRN3 functions

### Blocking function set in compliance with requirements:

The MRN3 has an external blocking input. By applying the auxiliary voltage to input D8/E8, the requested protection functions of the relay are blocked (refer to 5.7.1).

## 5. Operation and setting

### 5.1 Display

Function	Display shows	Pressed pushbutton	Corresponding LED	Type of relay
Normal operation	WW			all types
Measured operating values	Actual measured value Min. and max. values of voltage, frequency and vector surge	<SELECT/RESET> one time for each value	L1, L2, L3, f, min, max $\Delta\Theta$ df	MRN3-1 MRN3-2
Transformer ratio of the CT's	(SEK) 1.01 – 6500 = prim	<SELECT/RESET><+><->	L1, L2, L3	
Setting values: star/delta connection	Y/DELT	<SELECT/RESET><+><->	$\Delta/Y$	
Parameter switch/ext. Trigger for FR	SET1, SET2, B_S2, R_S2, B_FR, R_FR, S2_FR	<SELECT/RESET><+><->	P2	
Switch-over LED flash No LED flash	FLSH NOFL	<SELECT/RESET><+><->		
Under voltage (low set) tripping delay of low set element	setting value in volt setting value in seconds	<SELECT/RESET><+><-> one time for each value	U< tu<	
Under voltage (high set) tripping delay of high set element	setting value in volt setting value in seconds	<SELECT/RESET><+><-> one time for each value	U<< tu<<	
overvoltage (low set) tripping delay of low set element	setting value in volt setting value in seconds	<SELECT/RESET><+><-> one time for each value	U> tu>	
overvoltage (high set) tripping delay of high set element	setting value in volt setting value in seconds	<SELECT/RESET><+><-> one time for each value	U>> tu>>	
rated frequency	setting value in Hz	<SELECT/RESET><+><->	f <sub>N</sub>	
frequency measuring repetition	setting value	<SELECT/RESET><+><->	T	
frequency element f <sub>1</sub> tripping delay of frequency element f <sub>1</sub>	setting value in Hz setting value in seconds	<SELECT/RESET><+><-> one time for each value	f <sub>1</sub> tr <sub>1</sub>	
frequency element f <sub>2</sub> tripping delay of frequency element f <sub>2</sub>	setting value in Hz setting value in seconds	<SELECT/RESET><+><-> one time for each value	f <sub>2</sub> tr <sub>2</sub>	
frequency element f <sub>3</sub> tripping delay of frequency element f <sub>3</sub>	setting value in Hz setting value in seconds	<SELECT/RESET><+><-> one time for each value	f <sub>3</sub> tr <sub>3</sub>	
1-of-3/3-of-3 measurement threshold for vector surge	1Ph/3Ph	<SELECT/RESET><+><->	1/3	MRN3-1
setting value df/dt measuring repetition df/dt	setting value in Hz/s setting value in periods	<SELECT/RESET><+><-> one time for each value	$\Delta\Theta$ df dt	MRN3-2
Blocking	EXIT	<+> until max. setting value	LED of blocked parameter	
Undervoltage blocking of frequency and vector surge	setting value in Volt	<SELECT/RESET><+><->	f, $\Delta\Theta$ , df	

Function	Display shows	Pressed pushbutton	Corresponding LED	Type of relay
measuring (df/dt for MRN3-2)				
Slave address of serial interface	1 - 32	<SELECT/RESET><+><->	RS	
Baud-Rate <sup>1)</sup>	1200-9600	<SELECT/RESET> <+><->	RS	
Parity-Check <sup>1)</sup>	even odd no	<SELECT/RESET> <+><->	RS	
Recorded fault data: star-connection: U1, U2, U3	tripping values in Volt	<SELECT/RESET><+><-> one time for each phase	L1, L2, L3, U<, U<<, U>, U>>	
delta-connection: U12, U23, U31	tripping values in Volt	<SELECT/RESET><+><-> one time for each phase	L1, L2, L3 U<, U<<, U>, U>>	
frequency	tripping values in Hz	<SELECT/RESET><+><-> one time for each phase	f, f1, f2, f3	
rate of change of frequency	tripping value in Hz/s	<SELECT/RESET><+><->	df	MRN3-2
vector surge	tripping value in degree	<SELECT/RESET><+><-> one time for each phase	$\Delta\theta$ + L1, L2 or L3	MRN3-1
Delete failure memory	wait	<-> <SELECT/RESET>		
Enquiry failure memory	FLT1; FLT2.....	<-><+>	L1, L2, L3, U<, U<<, U>, U>>, f, Ddf/dt, $\Delta\theta$	
Save parameter?	SAV?	<ENTER>		
Save parameter!	SAV!	<ENTER> for about 3 s		
Trigger signal for the fault recorder	TEST, P_UP, A_PI, TRIP	<SELECT/RESET> <+><->	FR	
Number of fault occurrences	S = 2, S = 4, S = 8	<SELECT/RESET> <+><->	FR	
Display of date and time	Y = 99, M = 10, D = 1, h = 12, m = 2, s = 12	<SELECT/RESET> <+><->	<input type="checkbox"/>	
Software version	First part (e.g. D02-) Sec. part (e.g. 6.01)	<TRIP> one time for each part		
Manual trip	TRI?	<TRIP> three times		
Inquire password	PSW?	<SELECT/RESET>/<+>/<->/<ENTER>		
Relay tripped	TRIP	<TRIP> or fault tripping		
Secret password input	XXXX	<SELECT/RESET>/<+>/<->/<ENTER>		
System reset	WW	<SELECT/RESET> for about 3 s		

Table 5.1: Possible indication messages on the display

## 5.2 Setting procedure

In this paragraph the settings for all relay parameters are described in detail. For parameter setting a password has to be entered first (please refer to 4.4 of description "MR-Digital Multifunctional Relays").

## 5.3 System parameter

### 5.3.1 Display of residual voltage $U_E$ as primary quantity ( $U_{prim}/U_{sec}$ )

The residual voltage can be shown as primary measuring value. For this parameter the transformation ratio of the VT has to be set accordingly. If the parameter is set to "sec", the measuring value is shown as rated secondary voltage.

#### Example:

The voltage transformer used is of 10 kV/100 V. The transformation ratio is 100 and this value has to be set accordingly. If still the rated secondary voltage should be shown, the parameter is to be set to 1.

### 5.3.2 $\Delta/Y$ – Switch over

Depending on the mains voltage conditions, the input voltage transformers can be operated in delta or Y connection. Changeovers are effected via the <+> and the <-> keys and stored with <ENTER>.

### 5.3.3 Setting of nominal frequency

For proper functioning it is necessary to first adjust the rated frequency (50 or 60 Hz).

For this a distinction has to be made between the settings  $v = 50 \text{ Hz} / f = 50 \text{ Hz}$  or  $v = 60 \text{ Hz} / f = 60 \text{ Hz}$

The difference lies in the method of voltage measuring.

With the setting "v" = 50/60 Hz voltage measuring is independent of the existing frequency. This means, the voltage value can be correctly measured between 30 Hz and 80 Hz without adverse effects from the frequency.

With the setting "f" = 50/60 Hz the measured voltage value is influenced by the frequency. (see Table 5.2)

Declination of measuring value at 50Hz

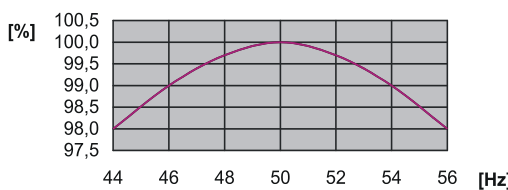

Declination of measuring value at 60Hz

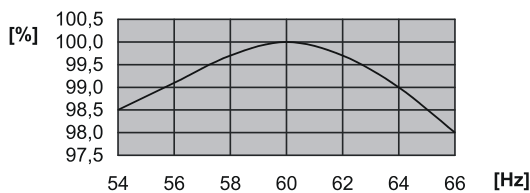



This difference in settings is required for the fault recorder. If the fault recorder is to be used, the setting must be  $f = 50$  Hz or  $f = 60$  Hz.

The different designations "f" or "v" have no influence on any of the other functions.

All frequency functions are determined by setting the nominal frequency, i.e. whether the set frequency thresholds are evaluated as over- or under frequency (see also chapter 5.4.4). Also the cycle duration (20 ms at 50 Hz and 16.67 ms at 60 Hz) derives from this setting which determines the minimum tripping delay for frequency elements f1 - f3 with an adjustable multiplier (see also chapter 5.4.5).

During setting of the nominal frequency a value in Hz is shown on the display.

Setting	v = 50	f = 50	v = 60	f = 60
Rated frequency	50 Hz	50 Hz	60 Hz	60 Hz
Influence on voltage measurement	none	0.5..1%/Hz (see table 5.2)	none	0.5..1%/Hz (see table 5.2)
Fault recorder	Recording distorted**	Recording correct***	Recording distorted**	Recording correct***
Influence on all other functions	none	none	none	none

Table 5.2: Deviation of measured value at 50 or 60 Hz

\* Setting is important for differentiation between over- and under frequency

\*\* Sample rate is variably adjusted to the momentarily measured frequency. 16 samples are always measured in one period.

\*\*\* Sample rate setting is fixed to 50 Hz or 60 Hz. 16 samples per 20 ms or 16.67 ms are always measured.

### 5.3.4 Display of the activation storage (FLSH/NOFL)

If after an activation the existing current drops again below the pickup value, e.g.  $U_{<}$ , without a trip has been initiated, LED  $U_{<}$  signals that an activation has occurred by flashing fast. The LED keeps flashing until it is reset again (push button <RESET>). Flashing can be suppressed when the parameter is set to NOFL.

### 5.3.5 Parameter switch/external trigger for the fault recorder

By means of the parameter-change-over switches it is possible to activate two different parameter sets. Switching over of the parameter sets can either be done by means of software or via the external inputs RESET or blocking input. Alternatively, the external inputs can be used for Reset or blocking and for the triggering of the fault recorder.

Software-parameter	Blocking input used as	RESET input used as
SET1	Blocking input	RESET input
SET2	Blocking input	RESET input
B_S2	Parameter switch	RESET input
R_S2	Blocking input	Parameter switch
B_FR	External triggering of the fault recorder	Reset input
R_FR	Blocking input	External triggering of the fault recorder
S2_FR	Parameter switch	External triggering of the fault recorder

With the settings SET1 or SET2 the parameter set is activated by software. Terminals C8/D8 and D8/E8 are then available as external reset input or blocking input.

With the setting B\_S2 the blocking input (D8, E8) is used as parameter-set change-over switch.  
With the setting R\_S2 the reset input (D8, E8) is used as parameter-set change-over switch.  
With the setting B\_FR the fault recorder is activated immediately by using the blocking input.  
On the front plate the LED FR will then light up for the duration of the recording. With the setting R\_FR the fault recorder is activated via the reset input. With the setting S2\_FR parameter set 2 can be activated via the blocking input and/or the fault recorder via the reset input. The relevant function is then activated by applying the auxiliary voltage to one of the external inputs.  
With the setting R\_FR the fault recorder is activated via the reset input. With the setting S2\_FR parameter set 2 can be activated via the blocking input and/or the fault recorder via the reset input.  
The relevant function is then activated by applying the auxiliary voltage to one of the external inputs

**Important note:**

When functioning as parameter change over facility, the external input RESET is not available for resetting. When using the external input BLOCKING the protection functions must be deactivated by software blocking separately (refer to chapter 5.7.1).

## 5.4 Protection parameters

### 5.4.1 Parameter setting of over- and under voltage supervision

The setting procedure is guided by two colored LEDs. During setting of the voltage thresholds the LEDs U<, U<<, U> and U>> are lit green. During setting of the trip delays  $t_{U>}$ ,  $t_{U>>}$ ,  $t_{U<}$  and  $t_{U<<}$  the according LEDs light up red.

#### Thresholds of the voltage supervision

During setting of the threshold U>, U>>, U< and U<< the displays shows the voltages directly in volt. The thresholds can be changed by the <+> <-> push buttons and stored with <ENTER>. The under voltage supervision (U< and U<<) as well as the overvoltage supervision (U> and U>>) can be de-activated by setting the threshold to "EXIT".

#### Tripping delay of voltage supervision

During setting of the tripping delays  $t_{U<}$ ,  $t_{U<<}$ ,  $t_{U>}$  and  $t_{U>>}$  the display shows the value directly in seconds. The tripping delay is changed via the push button <+> and <-> in the range of 0,04 s to 50 s and can be stored with the push button <ENTER>.

When setting the tripping delay to "EXIT" the value is infinite meaning only warning, no tripping.

### 5.4.2 Number of measuring repetitions (T) for frequency functions

In order to avoid false tripping of the unit at short voltage drops of the system voltage or interference voltages, MRN3 works with an adjustable measuring repetition. When the instantaneous frequency measuring value exceeds (at over frequency) or falls below (at under frequency) the set reference value, the counter is incremented, otherwise the counter is decremented down to the minimum value of 0. Only when the counter exceeds the value adjusted at T, alarm is given and after the tripping delay of the frequency element has elapsed the tripping command is given. The setting range for T is between 2 - 99.

#### Recommendation for setting:

For short tripping times, e.g. for machine protection or for mains decoupling T should be set in the range from 2 - 5.

At precision measurements, e.g. exact measurement of the system frequency a setting of T in the range from 5 - 10 is recommended.

### 5.4.3 Threshold of frequency supervision

The frequency supervision of MRN3 has three frequency elements independent from each other. Acc. to setting the pickup value above or below the nominal frequency, these elements can be used for over- or under frequency supervision.

Dependent on the preset nominal frequency  $f_N$  the pickup values from 30 Hz up to 70 Hz at  $f_N = 50$  Hz and from 40 Hz to 80 Hz at  $f_N = 60$  Hz can be set.

During setting of the pickup values  $f_1$  -  $f_3$  the display shows the values in Hz. A value of for instance 49,8 Hz is indicated with "4980".

The function of the individual frequency elements can be deactivated by setting the pickup values to "EXIT".

The setting value "EXIT" corresponds to the rated frequency.

#### 5.4.4 Tripping delays for the frequency elements

Tripping delays  $t_{f1}$  -  $t_{f3}$  of the four frequency elements can be set independently from  $t_{f1}$  min - 50 s. The minimum tripping delay  $t_{f1}$  min of the relay depends upon the number of set measuring repetitions T (periods) and amounts to:

T	tf,min
2...49	$(T+1) \cdot 20$ ms
50...69	$(T - 49) \cdot 50$ ms + 1 s
70...99	$(T - 69) \cdot 100$ ms + 2 s

When setting the tripping delay to "EXIT" by pressing push button <+> up to the maximum setting value, the corresponding tripping relay is blocked. Pickup of the frequency element is however displayed on the front plate by the corresponding LED, an assigned alarm relay is also activated. This setting applies to 50 Hz and 60 Hz.

#### 5.4.5 Parameter setting of vector surge supervision (MRN3-1)

Both the vector surge angle  $\Delta\Theta$  as well as the tripping logic concerning the vector surge have to be adjusted for a vector surge supervision.

If the tripping logic is set to 1-of-3 (= "1Ph" on the display), the relay trips as soon as the measured vector surge angle has exceeded the set value  $\Delta\Theta$  in one of the three phases. This is the more sensitive adjustment when compared with the three phase tripping logic 3-of-3 (= "3Ph" on the display), where tripping occurs only if the vector surge angle exceeds the set value in all three phases.

We recommend to choose the one phase tripping logic "1Ph". Only if this adjustment is too sensitive, adjustment "3Ph" should be used.

The recommended setting of the vector surge angle  $\Delta\Theta$  in a low impedance mains is 4 - 6 degrees. This setting is sufficient in most cases, because low impedance mains do not have a vector surge greater than this value. In case of an auto reclosing, this value is exceeded. In high impedance mains the setting should be 10° to 12° to avoid failure tripping when switching on or switching off big consumer loads.

The vector surge function of this device can be checked as follows:

- Generator in isolated operation: Switching off and on of loads (approx. 20% of the nominal generator capacity) must trip the relay. Later in normal isolated operation the tripping of the relay is inhibited.
- In mains parallel operation switching on and switching off of consumer loads and controlling the governor of the prime mover should not trip the relay.

If possible the test described under a) and b) should be double checked by a real auto reclosing.

##### Threshold for the vector surge supervision

When the pickup value of the vector surge supervision is set, a value in angular degree is indicated at the display. The pickup value requested can be adjusted by pushbuttons <+> and <-> in the range of 2° to 22°. LED  $\Delta\Theta$  lights up red during this procedure.

Important Information on the Vector Surge Supervision:

*Single Phase Vector Supervision "1-of-3" ("1Ph" on the Display)*

Within the Area „Safe Area“ the trip decision depends on the set Angle „Delta phi“ only (*please refer to figure Single Phase Vector Surge Supervision*).

Within the Area „Unsafe Area“ a trip decision is taken if the vector surge angle „Delta phi“ is exceeded or if the magnitude of the voltage vector is shrunk (percental related to the rated voltage). In order to prevent faulty tripping the effective area of the vector surge supervision can be limited by means of the parameter "UB<".

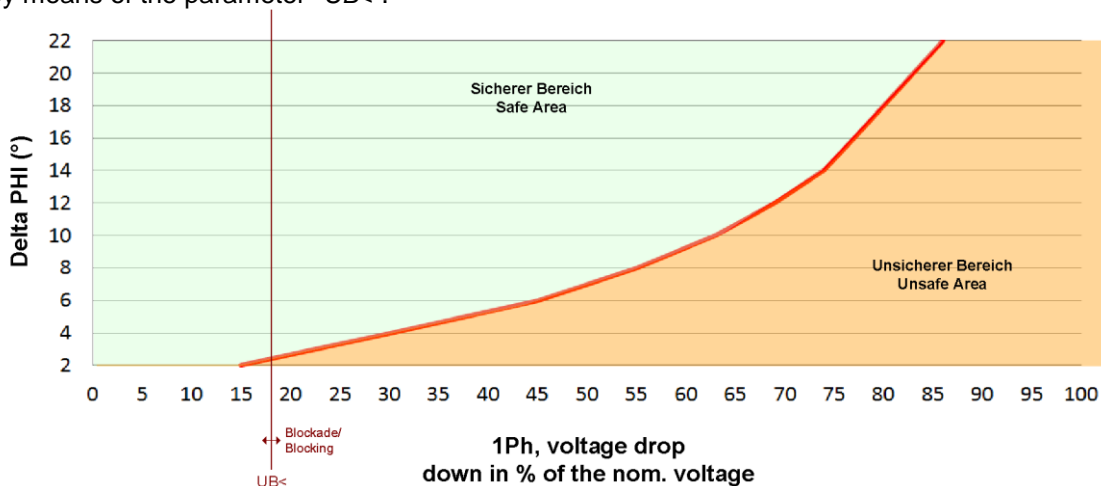

*Three Phase Vector Surge Supervision "3-of-3" ("1Ph" on the Display)*

Within the Area „Safe Area“ the trip decision depends on the set Angle „Delta phi“ only (*please refer to figure Three Phase Vector Surge Supervision*).

Within the Area „Unsafe Area“ a trip decision is taken if the vector surge angle „Delta phi“ is exceeded or if the magnitudes of the three voltage vectors are shrunk (percental related to the rated voltage). In order to prevent faulty tripping the effective area of the vector surge supervision can be limited by means of the parameter "UB<".

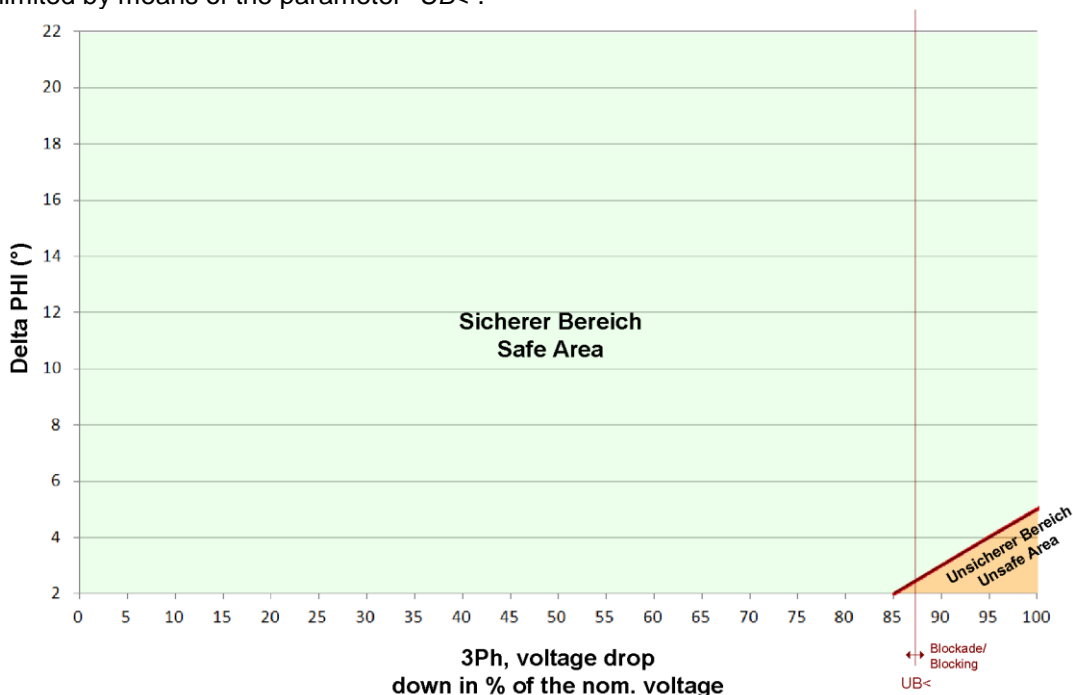

### 5.4.6 Parameter setting of frequency gradient (MRN3-2)

The pickup value of frequency gradient (parameter df) can be set between 0.2 to 10 Hz/s. The number of measuring repetitions (parameter dt) can be set between 2 - 64 cycles. This parameter defines the number of df/dt measurements, which have to exceed the set value, before tripping.

#### Setting information:

The power difference after mains failure causes a change in frequency, which can approximately be calculated as follows:

$$\frac{df}{dt} = -\frac{f_N}{T_A} \cdot \Delta P$$

With

$F_n$  = rated frequency

$T_a$  = starting time at rated torque

$\Delta P$  = per unit power deficit with reference to the rated active power of the generator

If the inertia time constant is known and a power difference given, the frequency gradient can be estimated by the a.m. equation. At a supposed power difference of 20% and an inertia time constant of 10 s, the frequency gradient is 1 Hz/s.

To prevent false tripping at loading, deloading or failure signals, we would recommend a setting value for dt of minimum 4 cycles.

### 5.4.7 Settable voltage threshold (df/dt at MRN3-2)

Correct frequency measuring or vector surge measuring cannot be obtained if the system volt-age is very low, for instance during generator start up or voltage failure. False tripping of the MRN3 in such cases is prevented by an adjustable voltage threshold UB. If the system voltage is below this threshold, these functions of the relay are blocked.

During adjustment of UB< LEDs f and  $\Delta\theta$  or df light up in the upper display part.

### 5.4.8 Adjustment of the slave address

By pressing push buttons <+> and <-> the slave address can be set in the range of 1 - 32. During this adjustment the LED RS lights up.

### 5.4.9 Setting of Baud-rate (applies for Modbus Protocol only)

Different transmission rates (Baud rate) can be set for data transmission via Modbus Protocol. The rate can be changed by push buttons <+> and <-> and saved by pressing <ENTER>.

### 5.4.10 Setting of parity (applies for Modbus Protocol only)

The following three parity settings are possible :

- "even" = even
- "odd" = odd
- "no" = no parity check

The setting can be changed by push buttons <+> and <-> and saved by pressing <ENTER>.

## 5.5 Adjustment of the fault recorder

The MRN3 is equipped with a fault recorder (see chapter 3.7). Three parameters can be determined.

### 5.5.1 Number of the fault recordings

The max. recording time is 16 s at 50 Hz or 13.33 s at 60 Hz.

The number of max. recordings requested has to be determined in advance. There is a choice of (1)\* 2, (3)\* 4 or (7)\* 8 recordings and dependent on this the duration of the individual fault recordings is defined, i.e.

(1)\* 2 recordings for a duration of 8 s (with 50 Hz) (6.66 s with 60 Hz)

(3)\* 4 recordings for a duration of 4 s (with 50 Hz) (3.33 s with 60 Hz)

(7)\* 8 recordings for a duration of 2 s (with 50 Hz) (1,66 s with 60 Hz)

\* is written over when a new trigger signal arrives

#### Caution:

If the fault recorder is used, the frequency should be set to  $f = 50$  Hz or  $f = 60$  Hz (see chapter 5.3.3).

### 5.5.2 Adjustment of trigger occurrences

There is a choice between four different occurrences:

P_UP (Pickup)	Storage is initiated after recognition of a general activation.
TRIP	Storage is initiated after a trip has occurred.
A_PI (After Pickup)	Storage is initiated after the last activation threshold was fallen short of.
TEST	Storing is activated by simultaneous actuation of the keys <+> and <->. During the recording time the display shows "Test".

### 5.5.3 Pre-trigger time ( $T_{pre}$ )

By the time  $T_{pre}$  it is determined which period of time prior to the trigger occurrence should be stored as well. It is possible to adjust a time between 0.05s and the max. recording interval (2, 4 and 8s). With keys <+> and <-> the values can be changed and with <ENTER> be saved.

## 5.6 Adjustment of the clock

When adjusting the date and time, LED ☉ lights up. The adjustment method is as follows:

Date :	Year	Y=00
	Month	M=00
	Day	D=00
Time :	Hour	h=00
	Minute	m=00
	Second	s=00

The clock starts with the set date and time as soon as the supply voltage is switched on. The time is safeguarded against short-term voltage failures (min. 6 minutes).

#### Note:

The window for parameter setting is located behind the measured value display. The parameter window can be accessed via the <SELECT/RESET> key.

## 5.7 Additional functions

### 5.7.1 Setting procedure for blocking the protection functions

The blocking function of the MRN3 can be set according to requirement. By applying the aux. voltage to D8/E8, the functions chosen by the user are blocked. Setting of the parameter should be done as follows:

- When pressing push buttons <ENTER> and <TRIP> at the same time, message "BLOC" is displayed (i.e. the respective function is blocked) or "NO\_B" (i.e. the respective function is not blocked). The LED allocated to the first protection function U< lights red.
- By pressing push buttons <+> <-> the value displayed can be changed.
- The changed value is stored by pressing <ENTER> and entering the password.
- By pressing the <SELECT/RESET> push button, any further protection function which can be blocked is displayed.
- Thereafter the menu is left by pressing <SELECT/RESET> again.
- If the <SELECT/RESET> key is actuated again, the blocking menu is left and the assignment mode is accessed^.

Function	Description	Display	LED
U<	Under voltage step 1	BLOC	red
U<<	Under voltage step 2	BLOC	red
U>	Overvoltage step 1	NO_B	red
U>>	Overvoltage step 2	NO_B	red
f1	Frequency step 1	BLOC	red
f2	Frequency step 2	BLOC	rec
f3	Frequency step 3	NO_B	red
$\Delta\Theta$	Vector surge	BLOC	red
df/dt	Frequency changing rate	BLOC	red

Table 5.3: Blockadefunktion für zwei Parametersätze

#### Assignment of the output relays

Unit MRN3 has five output relays. The fifth output relay is provided as permanent alarm relay for self supervision is normally on. Output relays 1 - 4 are normally off and can be assigned as alarm or trip-ping relays to the voltage functions which can either be done by using the push buttons on the front plate or via serial interface RS485. The assignment of the output relays is similar to the setting of parameters, however, only in the assignment mode. The assignment mode can be reached only via the blocking mode. By pressing push button <SELECT/RESET> in blocking mode again, the assignment mode is selected.

The relays are assigned as follows: LEDs U<, U<<, U> and U>>, f1, f2, f3 are two-colored and light up green when the output relays are assigned as **alarm relays** and tu<, tu<<, tu<, tu<<, tf1, tf2, tf3 df/dt and red as **tripping relays**.

#### Definition:

**Alarm relays** are activated at pickup.

**Tripping relays** are only activated after elapse of the tripping delay.



After the assignment mode has been activated, first LED U< lights up green. Now one or several of the four output relays can be assigned to under volt-age element U< as alarm relays. At the same time the selected alarm relays for under voltage element 1 are indicated on the display. Indication "1\_ \_ \_" means that output relay 1 is assigned to this under voltage element. When the display shows "\_ \_ \_ \_", no alarm relay is assigned to this under voltage element. The assignment of output relays 1 - 4 to the current elements can be changed by pressing <+> and <-> push buttons. The selected assignment can be stored by pressing push button <ENTER> and subsequent input of the password. By pressing push button <SELECT/RESET>, LED U< lights up red. The output relays can now be assigned to this voltage element as tripping relays.

Relays 1 - 4 are selected in the same way as de-scribed before. By repeatedly pressing of the <SELECT/RESET> push button and assignment of the relays all elements can be assigned separately to the relays. The assignment mode can be terminated at any time by pressing the <SELECT/RESET> push button for some time (abt. 3 s).

**Note:**

The function of jumper J2 described in general description "MR Digital Multifunctional Relays" does not apply for MRN3. For relays without assignment mode this jumper is used for parameter setting of alarm relays (activation at pickup or tripping).

A form is attached to this description where the setting requested by the customer can be filled-in. This form is prepared for telefax transmission and can be used for your own reference as well as for telephone queries.

Relay function		Output relays				Display- Indication	Corres- ponding LED
		1	2	3	4		
U<	alarm		X			_ 2 _ _	U<; green
tU<	tripping	X				1 _ _ _	tU< red
U<<	alarm		X			_ 2 _ _	U<< green
tU<<	tripping	X				1 _ _ _	tU<< red
U>	alarm		X			_ 2 _ _	U> green
tU>	tripping	X				1 _ _ _	tU> red
U>>	alarm		X			_ 2 _ _	U>> green
tU>>	tripping	X				1 _ _ _	tU>> red
f1	alarm			X		_ _ 3 _	f1 green
tf1	tripping	X				1 _ _ _	tf1 red
f2	alarm			X		_ _ 3 _	f2 green
tf2	tripping	X				1 _ _ _	tf2 red
f3	alarm			X		_ _ 3 _	f3 green
tf3	tripping	X				1 _ _ _	tf3 red
$\Delta\Theta$	tripping				X	_ _ _ 4	$\Delta\Theta$ red
df/dt	tripping				X	_ _ _ 4	df/dt red

Table 5.4: Example of assignment matrix of the output relay (default settings).

## 5.8 Indication of measuring values

### 5.8.1 Measuring indication

In normal operation the following measuring values can be displayed.

- Voltages (LED L1, L2, L3 green)
- In star connection all phase-to-neutral voltages
- In delta connection all phase-to-phase voltages
- Frequency (LED f green MRN3-1)
- Vector surge (LED green)
- Frequency gradient  $df/dt$  (LED  $df$  green; MRN3-2)

Min. and max. values prior to the last reset:

- Frequency (LED f + min or f + max)
- Vector surge (LED  $\Delta\theta$  + min or  $\Delta\theta$  + max)
- Frequency gradient (LED  $df$  + min or  $df$  + max)

### 5.8.2 Min./Max.- values

The MRN3 offers a minimum/maximum storage each for the measuring values of the vector surge as well as the frequency gradient. These min./max. values are mainly used to appraise the system quality. Always the highest and lowest values of **each cycle** are measured and stored until the next reset.

#### **Min./max. frequency measuring:**

The MRN3 ascertains the actual frequency from each cycle of the system voltage. These measuring values are entered into the min./max. storage. The latest entered min./max. values replace the previously stored values.

Dependent on the adjustment of  $dt$  and tripping delay, it is possible that the stored min./max. values are higher than the tripping threshold without causing a trip. The reason for this is storage of instantaneous values.

Min./Max. measuring of the frequency gradient:

The procedure described above applies also to storage of min./max. values of  $df/dt$  measurement. Since each instantaneous  $df/dt$  value is stored, high values can occur which, however, do not cause any tripping.

This can for instance happen during switching procedures where high positive and negative  $df/dt$  values occur, but they do not cause any tripping due to the special measuring method.

#### **Min./max. vector surge measuring :**

The procedure described above applies also to storage of min./max. values of vector surge measuring. Since each instantaneous  $\Delta\theta$  value is stored, also here high values are possible which, however, do not cause any tripping.

These min./max. measurements are of great advantage for long-time analysis of the grid quality.

#### **As to operation :**

After each reset (ref. 5.9.1) the min./max. storages are cleared. As from this instant there is no time limit for the min./max. storage until the next reset.

By repeatedly pressing the <SELECT/RESET> push button, the measuring values of the min./max. storage can be queried. The respective LEDs light up at the same time; e.g. during minimum frequency is displayed, LEDs "f" and "min" light up.

### 5.8.3 Unit of the measuring values displayed

The measuring values can optionally be shown in the display as a multiple of the "sec" rated value (x In) or as primary current (A). According to this the units of the display change as follows:

Indication as	Range	Unit
sec. voltage	000V – 999V	V
primary voltage	.000 – 999V	V
	1K00 – 9K99	KV
	10K0 – 99K9	KV
	100K – 999K	KV
	1M00 – 3M00	MV

Table 5.5: Units of the display

### 5.8.4 Indication of fault data

All faults detected by the relay are indicated on the front plate optically. For this purpose, the four LEDs (L1, L2, L3, f) and the four function LEDs (U<, U<<, U>, U>>, f1, f2, f3,  $\Delta\Theta$  und  $df/dt$ ) are equipped at MRN3. Not only fault messages are transmitted, the display also indicates the tripped protection function. If, for example an over current occurs, first the respective phase LED will light up. LED I> lights up at the same time. After tripping the LEDs are lit permanently.

## 5.9 Fault memory

When the relay is energized or is energized or trips, all fault data and times are stored in a non-volatile memory manner. The MRN3 is provided with a fault value recorder for max. five fault occurrences. In the event of additional trippings always the oldest data set is written over.

For fault indication not only the trip values are re-corded but also the status of LEDs. Fault values are indicated when push buttons <-> or <+> are pressed during normal measuring value indication.

- Normal measuring values are selected by pressing the <SELECT/RESET> button.
- When then the <-> button is pressed, the latest fault data set is shown. By repeated pressing the <-> button the last but one fault data set is shown etc. For indication of fault data sets abbreviations FLT1, FLT2, FLT3, ... are displayed (FLT1 means the latest fault data set recorded). At the same time the parameter set active at the occurrence is shown.
- By pressing <SELECT/RESET> the fault measuring values can be scrolled.
- By pressing <+> it can be scrolled back to a more recent fault data set. At first FLT5, FLT4, are always displayed. When fault recording is indicated (FLT1 etc), the LEDs flash in compliance with the stored trip information, i.e. those LEDs which showed a continuous light when the fault occurred are now blinking to indicate that it is not a current fault. LEDs which were blinking during trip conditions, (element had picked up) just briefly flash.
- If the relay is still in trip condition and not yet reset (TRIP is still displayed), no measuring values can be shown.
- To delete the trip store, the push button combination <SELECT/RESET> and <->, has to be pressed for about 3s. The display shows "wait".

**Recorded fault data:**

Measuring	Displayed value	Corresponding LED
Voltage	L1; L2; L3; L1/L2; L2/L3; L3/L1	L1; L2; L3
Frequency	f; f min f max	f; min; max
Frequency changing rate	df	df
Vektorsprung	$\Delta\Theta$	$\Delta\Theta$
Time stamp		
Date:	Y = 99	⊕
	M = 03	⊕
	D = 10	⊕
Time:	h = 17	⊕
	m = 21	⊕
	s = 14	⊕

**5.9.1 Reset**

All relays have the following three possibilities to reset the display of the unit as well as the output relay at jumper position J3=ON.

**Manual Reset**

Pressing the push button <SELECT/RESET> for some time (about 3 s)

**Electrical Reset**

Through applying auxiliary voltage to C8/D8

**Software Reset**

The software reset has the same effect as the <SELECT/RESET> push button (see also communication protocol of RS485 interface)

The display can only be reset when the pickup is not present anymore (otherwise "TRIP" remains in display).

During resetting of the display the parameters are not affected.

**5.9.2 Erasure of fault storage**

To delete the trip store, the push button combination <SELECT/RESET> and <->, has to be pressed for about 3s. The display shows "wait".

## 6. Relay testing and commissioning

The following test instructions should help to verify the protection relay performance before or during commissioning of the protection system. To avoid a relay damage and to ensure a correct relay operation, be sure that:

- The auxiliary power supply rating corresponds to the auxiliary voltage on site.
- The rated frequency and rated voltage of the re-lay correspond to the plant data on site.
- The voltage transformer circuits are connected to the relay correctly.
- All signal circuits and output relay circuits are connected correctly.

### 6.1 Power-On

#### NOTE!

Prior to switch on the auxiliary power supply, be sure that the auxiliary supply voltage corresponds to the rated data on the type plate.

Switch on the auxiliary power supply to the relay and check that the message "WW" appears on the display and the self supervision alarm relay (watchdog) is energized (Contact terminals D7 and E7 closed).

It may happen that the relay is tripped because of under- voltage condition after power-on. (The message "TRIP" on the display and LED L1, L2, L3 and U< light up red). An under voltage condition has been detected after power-on, because no in-put voltages are applied to the relay.

In this case:

- Press the push button <ENTER>, thus entering into the setting mode. Now set the parameters U< and U<< to "EXIT" to block the undervoltage functions. After that, press the <SELECT/RESET> for app. 3 s to reset the LEDs and "TRIP" message.
- The under voltage tripping after power on can also be eliminated by applying three phase rated voltages after power-on and reset the LED and "TRIP" message.
- Apply auxiliary voltage to the external blocking input (Terminals E8/D8) to inhibit the under voltage functions (refer to 6.5) and press the <SELECT/RESET> for app. 3 s to reset the LEDs and "TRIP" message.

### 6.2 Testing the output relays

#### NOTE!

Prior to commencing this test, interrupt the trip circuit to the circuit breaker if tripping is not desired. By pressing the push button <TRIP> once, the display shows the first part of the software version of the relay (e.g. „D08-“). By pressing the push button <TRIP> twice, the display shows the second part of the software version of the relay (e.g. „4.01“. The software version should be quoted in all correspondence. Pressing the <TRIP> button once more, the display shows "PSW?". Please enter the correct password to proceed with the test. The message "TRI?" will follow. Confirm this message by pressing the push button <TRIP> again. All out-put relays should then be activated and the self supervision alarm relay (watchdog) be deenergized one after another with a time interval of 1 second. Thereafter, reset all output relays back to their normal positions by pressing the push button <SELECT/RESET>.

## 6.3 Checking the set values

By repeatedly pressing the push button <SELECT>, all relay set values may be checked. Set value modification can be done with the push button <+><-> and <ENTER>. For detailed information about that, please refer to chapter 4.3 of the description "MR – Digital multifunctional re-lays".

As relay input energizing quantities, three phase voltages should be applied to MRN3 relay input circuits. Depending on the system conditions and the voltage transformer used, three voltages can be connected to the relay input circuits with either star or delta connection. In case of a star connection the phase-to-neutral voltage will be applied to the voltage input circuits, while the phase-to-phase voltages will be connected to the voltage input circuits in case of a delta connection. The voltage in-put connection must be set as a parameter, and should correspond with the actual voltage input connection:

Star connection: Phase-to-neutral voltages will be measured and evaluated.

Delta connection: Phase-to-phase voltages will be measured and evaluated.

## 6.4 Secondary injection test

### 6.4.1 Test equipment

- Voltmeter and frequency meter with class 1 or better,
- auxiliary power supply with the voltage corresponding to the rated data on the type plate,
- three-phase voltage supply unit with frequency regulation (Voltage: adjustable from 0 to 2 x UN; Frequency: adjustable from 40 - 70 Hz),
- timer to measure the operating time (Accuracy class 10 ms),
- switching device and Test leads and tools

### 6.5 Example of test circuit

For testing of the MRN3 relay, a three phase volt-age source with adjustable voltage and frequency is required. Figure 6.1 shows an example of a three-phase test circuit energizing the MRN3 relay during test. The three phase voltages are applied to the relay in Y-connection.

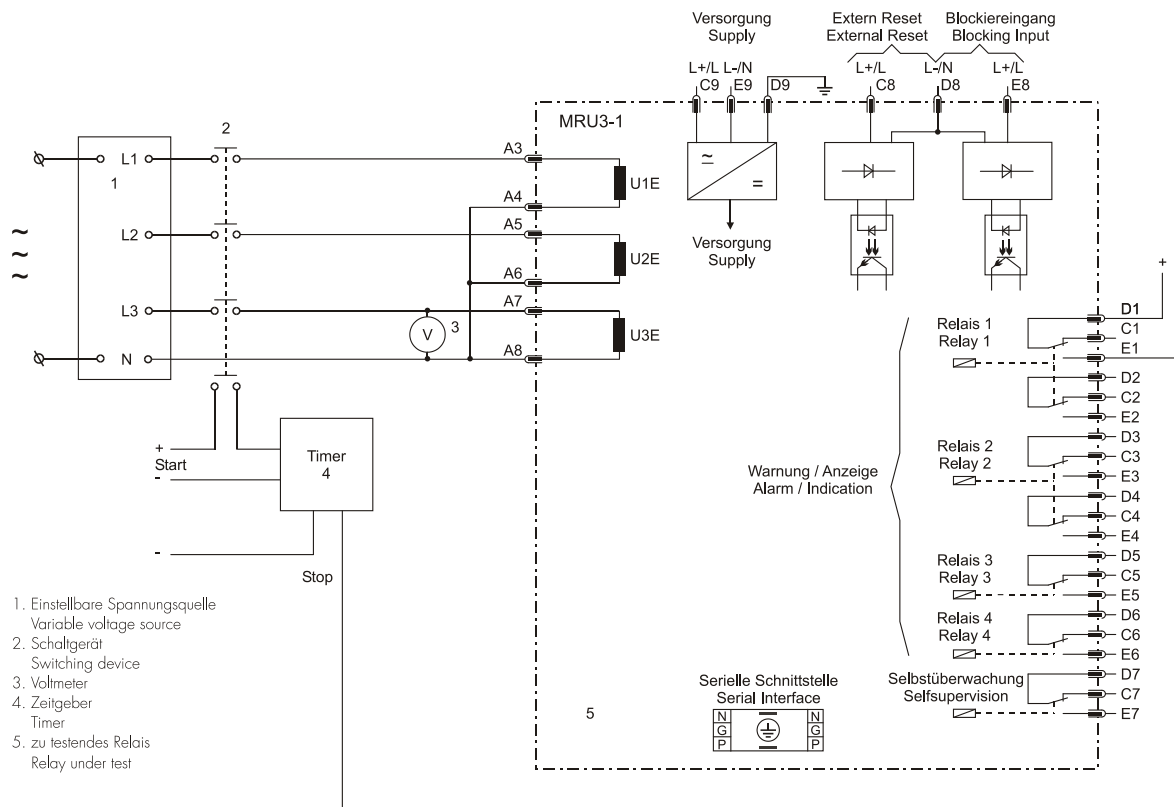

Figure 6.1: Test circuit

For testing the vector surge function of the relay, a test circuit which can produce phase angle change (vector surge) is required to simulate mains failures (please refer to chapter 6.5.6). For testing the df/dt function of the relay, a special test equipment is required, which produces a constant rate of change of frequency.

### 6.5.1 Checking the input circuits and measuring functions

Apply three voltages of rated value to the voltage input circuits (terminals A3 - A8) of the relay. Check the measured voltages, frequency and vector surge on the display by pressing the push button <SELECT/RESET> repeatedly. The displayed measuring voltages (shown in Volt) are dependent on the wiring of the input voltage converters and the set transformation ratio.

The voltages are indicated on the display in volts.

At Y-connection:

- Phase-to-neutral voltages: LED L1, L2, L At Delta-connection:
- Phase-to-phase voltages: LED L1+L2, L2+L3, L3+L1

The frequency is indicated on the display in Hz: LED f (system frequency = 50.01Hz, Indication = 5001)

The vector surge is indicated on the display in degrees (for MRN3-1): LED  $\Delta\theta$  (Indication  $\Delta\theta$  in  $^\circ$ )

The rate of change of frequency (LED df) is indicated on the display in Hz/s (for MRN3-2)

Change the voltages around the rated value and check the measured voltages on the display.

Change the system frequency around the rated frequency and check the measured frequency on the display.

Compare the voltage and frequency on display with the signal on voltmeter and frequency meter. The deviation for the voltage must not exceed 1% and for frequency <0.01 Hz.

By using an RMS-metering instrument, a greater deviation may be observed if the test voltage contains harmonics. Because the MRN3 relay measures only the fundamental component of the input signals, the harmonics will be rejected by the internal DFFT-digital filter. Whereas the RMS-metering instrument measures the RMS-value of the input signals.

### 6.5.2 Checking the operating and resetting values of the over/under voltage functions

**Note:**

When the measuring voltage is connected or disconnected, vector surge tripping or df/dt tripping can occur. In order to ensure a trouble-free test procedure, the vector surge function or df/dt function of the relay have to be blocked before tests are started.

Apply three voltages with the rated value and gradually increase (decrease) the voltages until the relay starts, i.e. at the moment when the LED U> (or U<) lights up or the voltage alarm output relay (contact terminals D4/E4) is activated. Read the operating voltage indicated by the voltmeter. The deviation must not exceed 1% of the set operating value.

Furthermore, gradually decrease (increase) the voltages until the relay resets, i.e. the voltage alarm output relay is disengaged. Check that the dropout to pickup ratio for voltage is greater than 0.97 (for overvoltage function) or smaller than 1.03 (for under voltage).

### 6.5.3 Checking the relay operating time of the over/undervoltage functions

To check the relay's operating time, a timer must be connected to the trip output relay contact (Contact terminals D1/E1). The timer should be started simultaneously with the voltage change from sound condition to a faulty condition and stopped by the trip relay contact. The operating time measured by timer should have a deviation about 3% of the set value or <20 ms.



## 6.5.4 Checking the operating and resetting values of the over/under frequency functions

### Note:

Due to frequency changes, vector surge tripping or  $df/dt$  - tripping can occur during frequency tests. In order to ensure a trouble-free test procedure, the vector surge function or  $df/dt$  function of the relay have to be blocked before tests are started.

During frequency tests, each of the frequency elements should be tested separately. This makes it necessary that the other frequency elements of the relay have to be blocked by setting the frequency pickup values

$f_1 - f_3$  to "EXIT". For testing the pickup and dropout to pickup values, the test frequency has to be increased (decreased) until the relay is energized. This is indicated by lighting up of LEDs  $f_1 - f_3$ . When comparing the values displayed with those of the frequency meter, the deviation must not exceed 0.01 Hz. The dropout to pickup values are ascertained by increasing (decreasing) the test frequency slowly until the output relay releases.

The dropout to pickup value for over frequency must be  $>0.99$ , and for under frequency  $<1.01$ .

## 6.5.5 Checking the relay operating time of the over/underfrequency functions

The operating time of the over/under frequency functions can be tested in the similar manner as in chapter 6.5.3 for over/under voltage functions.

## 6.5.6 Checking the vector surge function

With the help of an advanced relay test equipment a phase shift (vector surge) on the voltage signal can be obtained to test the vector surge function of MRN3 relay. If there is no such testing facility available, a very simple simulation circuit may be used to test the vector surge function of the relay with a sufficient accuracy.

Figure 6.2 shows the possibility to simulate a phase shift by means of a RC circuit. Closing or opening the switch S1 causes the phase angle of the input voltage to change depending on the adjustable resistor R.

The phase angle obtained may be calculated with the following formula and is almost independent on the test voltages.

In case of a 3-phase vector surge, the angle can be calculated with the following formula if the parameters  $R_0$ , R and C are known:

$$\Delta\theta = \arctg \frac{1}{R_0 \cdot \omega \cdot C} - \arctg \frac{1}{(R_0 + R) \cdot \omega \cdot C}$$

Example:  $R_0 = 1 \text{ Ohm}$ ,  $R = 363 \text{ Ohm}$ ,  $C = 3 \text{ }\mu\text{F}$

then:  $\Delta\theta \cong 19^\circ$

Usually the voltage source impedance  $R_0$  is negligible, hence  $R_0$  may be assumed zero. Thus, the value of R may be calculated using the following simplified formula:

$$\Delta\theta = 90^\circ - \arctg \frac{1}{R \cdot \omega \cdot C}$$

### Note!

Using the above test circuit with single-phase vector surge, the resulting measured angle  $\Delta\theta$  is about half the value of  $\Delta\theta$  calculated for a 3-phase vector surge.

To make tripping possible during a one phase test procedure, the vector surge tripping has to be set to "1Ph".

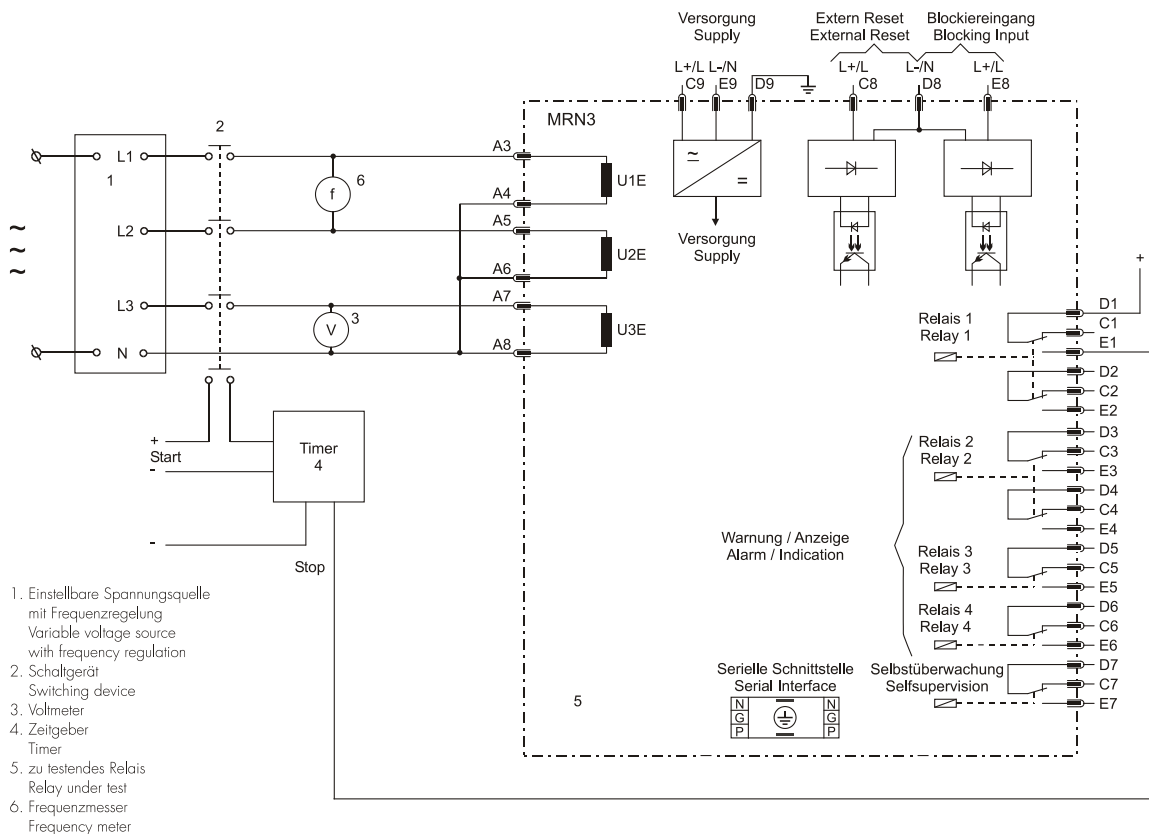

Figure 6.2: Test circuit for the vector surge function

### 6.5.7 Checking the external blocking and reset functions

The external blocking input is free programmable by the user.

To test the blocking function apply auxiliary supply voltage to the external blocking input of the relay (terminals E8/D8). Inject a test voltage which could cause tripping for the testes functions. Observe that there is no trip and alarm for those functions.

Remove the auxiliary supply voltage from the blocking input. Apply test voltages to trip the relay (message „TRIP“ on the display). Return the test voltages to the sound condition and apply auxiliary supply voltage to the external reset input of the relay (terminals C8/D8). The display and LED indications should be reset immediately.

## 6.6 Primary injection test

Generally, a primary injection test could be carried out in the similar manner as the secondary injection test described above. With the difference that the protected power system should be, in this case, connected to the installed relays under test „on line“, and the test voltages should be injected to the relay through the voltage transformers with the primary side energized. Since the cost and potential hazards are very high for such a test, primary injection tests are usually limited to very important protective relays in the power system.

Because of its powerful combined indicating and measuring functions, the MRN3 relay may be tested in the manner of a primary injection test without extra expenditure and time consumption.

In actual service, for example, the measured volt-age and frequency values on the MRN3 relay display may be compared phase by phase with the concerned indications of the instruments of the switchboard to verify that the relay works and measures correctly.

## 6.7 Maintenance

Maintenance testing is generally done on site at regular intervals. These intervals vary among users depending on many factors: e.g. the type of protective relays employed; the importance of the primary equipment being protected; the user's past experience with the relay, etc.

For electromechanical or static relays, maintenance testing will be performed at least once a year according to the experiences. For digital relays like MRN3, this interval can be substantially longer. This is because:

- The MRN3 relays are equipped with very wide self-supervision functions, so that many faults in the relay can be detected and signalized during service. Important: The self-supervision output relay must be connected to a central alarm panel!
- The combined measuring functions of MRN3 relays enable supervision the relay functions during service.
- The combined TRIP test function of the MRN3 relay allows to test the relay output circuits.

A testing interval of two years for maintenance will, therefore, be recommended.

During a maintenance test, the relay functions including the operating values and relay tripping times should be tested.

## 7. Technical data

### 7.1 Measuring input circuits

Rated data:	Nominal voltage $U_i$	100 V, 230 V, 400 V
	Nominal frequency $f_N$	40 - 70 Hz
Power consumption in voltage circuit:		<1 VA
Thermal rating: continuously		2 x $U_N$
Undervoltage lockout for frequency and vector surge measurement:		$U_{<}$ adjustable (5%...100% $U_N$ )

### 7.2 Common data

Dropout to pickup ratio:	for $U_{>}/U_{>>}$ : >97%; for $U_{<}/U_{<<}$ : <103%	for $f_{>}/f_{>>}$ : >99.97%; for $f_{<}/f_{<<}$ : <100.03%
Dropout time:		60 ms
Time lag error class index E:		±10 ms
Minimum operating time:		40 ms
Max. allowed interruption of the auxiliary supply without a facting the function of the device:		50 ms
Influences on voltage measuring:		
Aux. voltage:		in the range $0.8 < U_H/U_{HN} < 1.2$ no additional influences to be measured
Frequency:		in the range $0.8 < f/f_N < 1.4$ (for $f_N = 50$ Hz) <0.15% / Hz
Harmonics:		up to 20% of the 3rd harmonic <0.1% per percent of the 3rd harmonic up to 20% of the 5th harmonic <0.05% per percent of the 5th harmonic
Influences on frequency measuring:		
Aux. voltage:		in the range $< 0.8 U_N/U_{HN} < 1.2$ no additional Influences to be measured
Frequency:		no influences
Influences on delay time:		no additional influences to be measured

### 7.3 Setting ranges and steps

Function	Parameter	Setting range	Steps	Tolerance
Transformer ratio	$U_{p\_rim}/U_{sek}$	(SEC) 1.01...6500	0.01; 0.02; 0.05; 0.1; 0.2; 0.5; 1.0; 2.0; 5.0; 10; 20; 50	
Rated frequency	$f_N$	$f = 50 \text{ Hz} / f = 60 \text{ Hz}$		
Switch group	$\Delta/Y$	$\Delta = \text{Delta}/Y = \text{Stern}$		
Switch over	P2/FR	SET1/SET2/B_S2/R_S2/B_FR/R_FR/S2_FR		
LED blinking at pick-up		FLSH/NOFL		
$U_{<<<}$	$U_{<<<}$	$U_N = 100 \text{ V:}$ 2...200 V (EXIT) $U_N = 230 \text{ V:}$ 2...460 V (EXIT) $U_N = 400 \text{ V:}$ 4...800 V (EXIT) 0.04...50 s (EXIT)	1 V 1 V 2 V 0.01; 0.02; 0.05; 0.1; 0.2; 0.5; 1.0; 2.0 s	$\pm 1\%$ of set value or $< 0.3\% U_N$  $\pm 1\%$ or $+15 \text{ ms}/-35 \text{ ms}$
$U_{>>>}$	$U_{>>>}$ $t_{U>}$ $t_{U>>>}$	$U_N = 100 \text{ V:}$ 2...200 V (EXIT) $U_N = 230 \text{ V:}$ 2...460 V (EXIT) $U_N = 400 \text{ V:}$ 4...800 V (EXIT) 0,04...50 s (EXIT)	1 V 1 V 2 V 0.01; 0.02; 0.05; 0.1; 0.2; 0.5; 1.0; 2.0 s	$\pm 1\%$ of set value or $< 0,3\% U_N$  $\pm 1\%$ or $+15 \text{ ms}/-35 \text{ ms}$
Frequency measuring repetition	T	2...99 (Cycles)	1	
Frequency element 1 - 3	$f_1 - f_3$ $t_{f1} - t_{f3}$	30...49.99; EXIT; 50.01...70 Hz <sup>1</sup> 40...59.99; EXIT; 60.01...80 Hz <sup>2</sup> $t_{f,min}^3$ ...50 s; EXIT	0.1; 0.01 Hz 0.01; 0.02; 0.05; 0.1; 0.2; 0.5; 1.0; 2.0 s	0.04 Hz $\pm 1\%$ or $\pm 20 \text{ ms}$
df/dt-Step	df	0,2...10 Hz/s (EXIT)	0.1; 0.2; 0.5 Hz/s	0.1 Hz/s
df/dt-Measuring repetition	dt	2...64 Periods	1	
$\Delta\Theta$	$\Delta\Theta$	2°...22° (EXIT)	1°	$\pm 1^\circ$
Vector surge logic	1/3	1Ph / 3Ph		
Voltage threshold for frequency measuring	$U_{B<}$ (LED 'f+' $\Delta\Theta/df$ )	$U_N = 100 \text{ V:}$ 5...100 V $U_N = 230 \text{ V:}$ 12...230 V $U_N = 400 \text{ V:}$ 20...400 V	1 V 1 V 2 V	$\pm 1\%$ of set value or $< 0.3\% U_N$

Table 7.1: Setting ranges and steps

<sup>1)</sup> At 50 Hz rated frequency

<sup>2)</sup> At 60 Hz rated frequency

<sup>3)</sup>  $t_{f,min}$  min. time delay;  $t_{f,min} = (T+1) \times 20 \text{ ms}$

<sup>4)</sup> only Modbus

### 7.3.1 Interface parameter

Function	Parameter	Modbus-Protocol	RS485 Open Data Protocol
RS	Slave-Address	1 - 32	1 - 32
RS	Baud-Rate*	1200, 2400, 4800, 9600	9600 (fixed)
RS	Parity*	even, odd, no	"even Parity" (fixed)

Table 7.2: Interface parameter \*only Modbus Protocol

### 7.3.2 Parameters for the fault recorder

Function	Parameter	Adjustment example
FR	Number of recordings	(1)* 2 x 8 s; (3)* 4 x 4 s; (7)* 8 x 2 s (with 50 Hz) (1)* 2 x 6.66 s, (3)* 4 x 3.33 s, (7)* 8 x 1.66 s (60 Hz)
FR	Saving of the recording at the occurrence	P_UP; TRIP; A_PI; TEST
FR	Pre-trigger-time	0.05 s – 8.00 s

Table 7.3: Parameters for the fault recorder

\* is written over when a new trigger signal arrives

## 7.4 Output relays

Relay type	Trip relays/change-over contacts	Alarm relays/change-over contacts
MRN3	2/2	3/1

Table 7.4: Output relays

## 8. Order form

<b>Mains decoupling relay</b>		<b>MRN3-</b>			
with voltage-, frequency and vector surge supervision			<b>1</b>		
Voltage, frequency and df/dt-supervision			<b>2</b>		
Rated voltage	100 V			<b>1</b>	
	230 V			<b>2</b>	
	400 V			<b>4</b>	
Housing (12TE)	19"-rack				<b>A</b>
	Flush mounting				<b>D</b>
RS485	Alternatively with Modbus Protocol				<b>-M</b>

Technical data subject to change without notice!

## Setting list MRN3

Project: \_\_\_\_\_ Job.-no.: \_\_\_\_\_

Function group: = \_\_\_\_\_ Location: + \_\_\_\_\_ Relay code: - \_\_\_\_\_

Relay functions: \_\_\_\_\_ Password: \_\_\_\_\_

### Setting of the parameters

#### System parameter

Function		Unit	Relay type MRN3-1	MRN3-2	Default settings Set 1/Set 2	Actual settings Set 1/Set 2
$U_{prim}/U_{sek}$	Voltage transformer ratio		X	X	SEK	
$\Delta/Y$	Input voltage correction dependent on the connection of the input transformer		X	X	Y	
$f_N$	Rated frequency	Hz	X	X	$v = 50$ Hz	
LED Flash	Display of the activation storage		X	X	FLSH	
P2	2 parameter sets/ext. Trigger for FR		X	X	SET1	

#### Protection parameter

Function		Unit	Default settings Set 1 / Set 2	Actual settings Set 1 / Set 2
			Set 1 / Set 2	Set 1 / Set 2
$U_{<}$	pickup value for under voltage element (low set)	V	90/210/360*	
$t_{U<}$	tripping delay for under voltage element	s	0.04	
$U_{<<}$	pickup value for under voltage element (high set)	V	80/190/320*	
$t_{U<<}$	tripping delay for under voltage element	s	0.04	
$U_{>}$	pickup value for overvoltage element (low set)	V	110/250/440*	
$t_{U>}$	tripping delay for overvoltage element	s	0.04	
$U_{>>}$	pickup value for overvoltage element (high set)	V	120/270/480*	
$t_{U>>}$	tripping delay for overvoltage element	s	0.04	
T	frequency measuring repetition in periods	cycles	4	
$f_1$	pickup value for frequency element 1	Hz	4800	
$t_{f1}$	tripping delay for frequency element 1	s	0.1	
$f_2$	pickup value for frequency element 2	Hz	4900	
$t_{f2}$	tripping delay for frequency element 2	s	0.1	
$f_3$	pickup value for frequency element 3	Hz	5100	
$t_{f3}$	tripping delay for frequency element 3	s	0.1	
df	pickup value for rate of frequency (dt/dt) in	Hz/s	EXIT	
dt	measuring repetition for df/dt	periods	4	
1/3	vector surge tripping logic		1PH	
$\Delta\theta$	pickup value for vector surge	°	2.0	
$U_{B<}$	voltage threshold value for frequency and vector surge measuring (or df/dt)	V	10/23/40*	
RS	Slave address of the serial interface		1	
RS**	Baud-Rate		9600	
RS**	Parity-Check		even	

\* thresholds dependent on rated voltage 100 V / 230 V / 400 V

\*\* only Modbus



### Fault recorder

Function		Unit	Default settings	Actual settings
FR	Number of recordings		4	
FR	Saving of the recording at the occurrence		TRIP	
FR	Time prior to trigger impulse	s	0.05	
⊕	Year setting	year	Y=00	
⊕	Month setting	month	M=00	
⊕	Day setting	day	D=00	
⊕	Setting of the hour	hour	h=00	
⊕	Setting of the minute	minute	m=00	
⊕	Setting of the setting	second	s=00	

### Blocking function

Parameter set	Default settings				Actual settings			
	Blocking		Not blocking		Blocking		Not blocking	
	Set 1	Set 2	Set 1	Set 2	Set 1	Set 2	Set 1	Set 2
U<	X		X					
U<<	X		X					
U>		X		X				
U>>		X		X				
f1	X		X					
f2	X		X					
f3		X		X				
$\Delta\theta$	X		X					
df/dt	X		X					

### Assignment of the output relays

Function	Relay 1		Relay 2		Relay 3		Relay 4	
	Default settings	Actual settings	Default settings	Actual settings	Default settings	Actual settings	Default settings	Actual settings
U< alarm			X					
t <sub>U&lt;</sub> tripping	X							
U<< alarm			X					
t <sub>U&lt;&lt;</sub> tripping	X							
U> alarm			X					
t <sub>U&gt;</sub> tripping	X							
U>> alarm			X					
t <sub>U&gt;&gt;</sub> tripping	X							
f1 alarm					X			
t <sub>f1</sub> tripping	X							
f2 alarm					X			
t <sub>f2</sub> tripping	X							
f3 alarm					X			
t <sub>f3</sub> tripping	X							
$\Delta\theta$ tripping							X	
df/dt tripping							X	

**Setting of code jumpers**

Code jumper	J1		J2		J3	
	Default settings	Actual settings	Default settings	Actual settings	Default settings	Actual settings
Plugged						
Not plugged	X		No function		X	

Code jumper	Low/High-range for Reset input		Low/High-range for blockage input	
	Default settings	Actual settings	Default settings	Actual settings
Low=plugged	X		X	
High=not plugged				

All settings must be checked at site and should the occasion arise, adjusted to the object/item to be protected.

This technical manual is valid for

software version number: D01-8.08 (MRN3-1)  
D04-8.08 (MRN3-2)

Modbus version number: D51-1.13 (MRN3-1)  
D54-1.13 (MRN3-2)

# HighTECH Line

<https://docs.SEGelectronics.de/mrn3>  
<https://docs.SEGelectronics.de/mr>

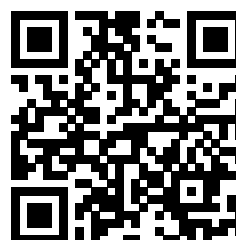
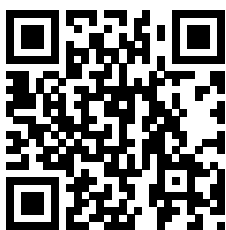

SEG Electronics GmbH reserves the right to update any portion of this publication at any time. Information provided by SEG Electronics GmbH is believed to be correct and reliable. However, SEG Electronics GmbH assumes no responsibility unless otherwise expressly undertaken.



SEG Electronics GmbH  
Krefelder Weg 47 • D-47906 Kempen (Germany)  
Postfach 10 07 55 (P.O.Box) • D-47884 Kempen (Germany)  
Telephone: +49 (0) 21 52 145 1

Internet: [www.SEGelectronics.de](http://www.SEGelectronics.de)

Sales  
Telephone: +49 (0) 21 52 145 331  
Fax: +49 (0) 21 52 145 354  
E-mail: [info@SEGelectronics.de](mailto:info@SEGelectronics.de)

Service  
Telephone: +49 (0) 21 52 145 614  
Fax: +49 (0) 21 52 145 354  
E-mail: [info@SEGelectronics.de](mailto:info@SEGelectronics.de)

SEG Electronics has company-owned plants, subsidiaries, and branches, as well as authorized distributors and other authorized service and sales facilities throughout the world.

Complete address / phone / fax / email information for all locations is available on our website.