

## WIRING DIAGRAMS

High **PROTEC** | PROTECTION TECHNOLOGY  
MADE SIMPLE

**MRMV4** | Motor Protection

Version: 3.11

Original document

English

This document does not replace the Technical Manual.

# MRMV4-2A0AAA

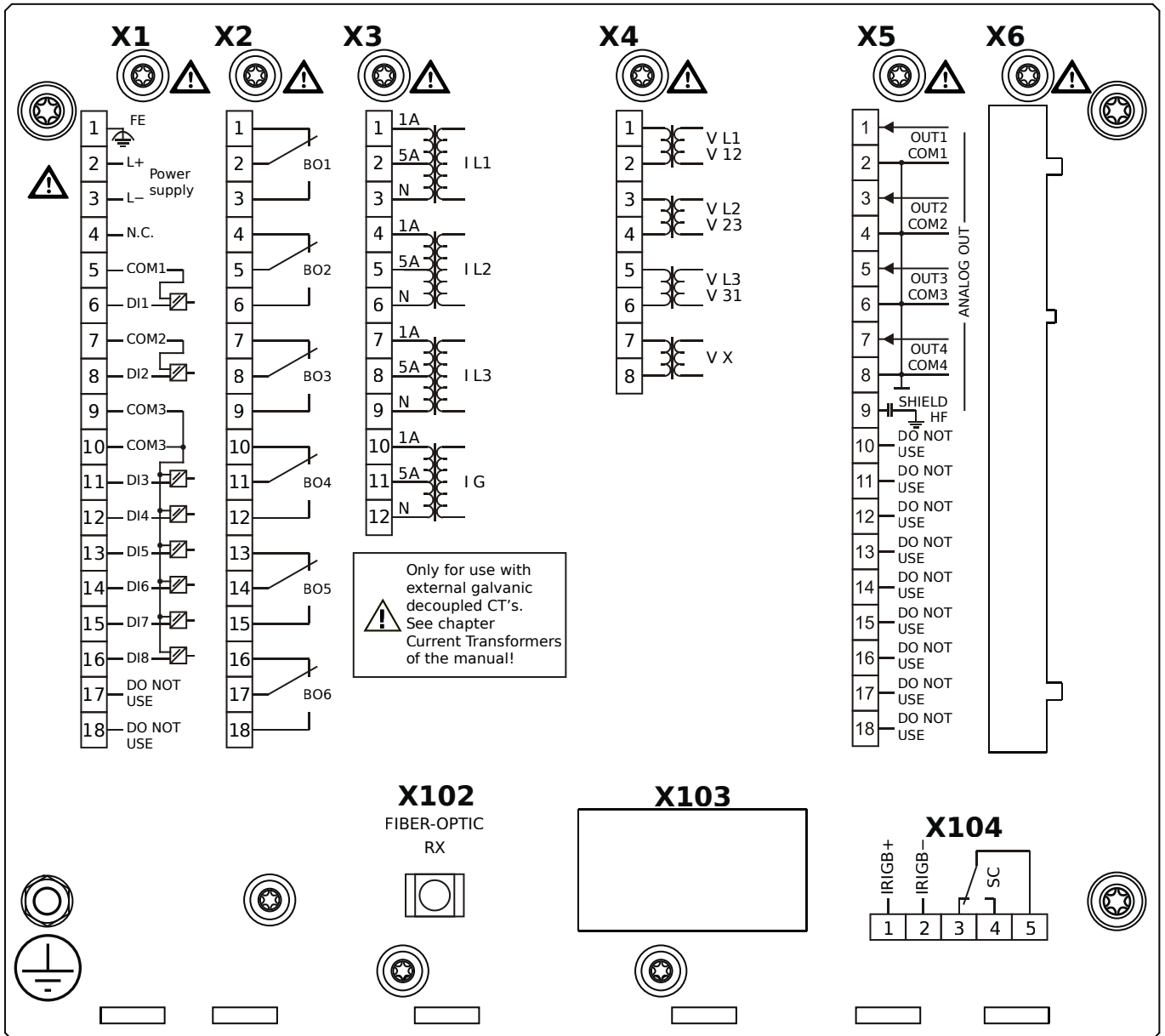

## Housing B2, small display, door mounting

- X1** – DI8-X1: Wide-range power supply unit, incl. 2 non-grouped digital inputs and 6 grouped digital inputs
- X2** – OR6: Assembly Group with 6 Output Relays (Changeover / Form C)
- X3** – TI: Standard current measuring card
- X4** – TU: Card with 4 voltage transformer measuring inputs (0 ... 800 VAC, under UL: 0 ... 600 VAC)
- X5** – AnO4: Analog Outputs
- X102** – Universal Resistance-Temperature Detector (URTD) input, Fiber optics interface, Versatile Link
- X104** – IRIG-B00X, incl. System Contact (Supervision Contact)

# MRMV4-2A0AAB

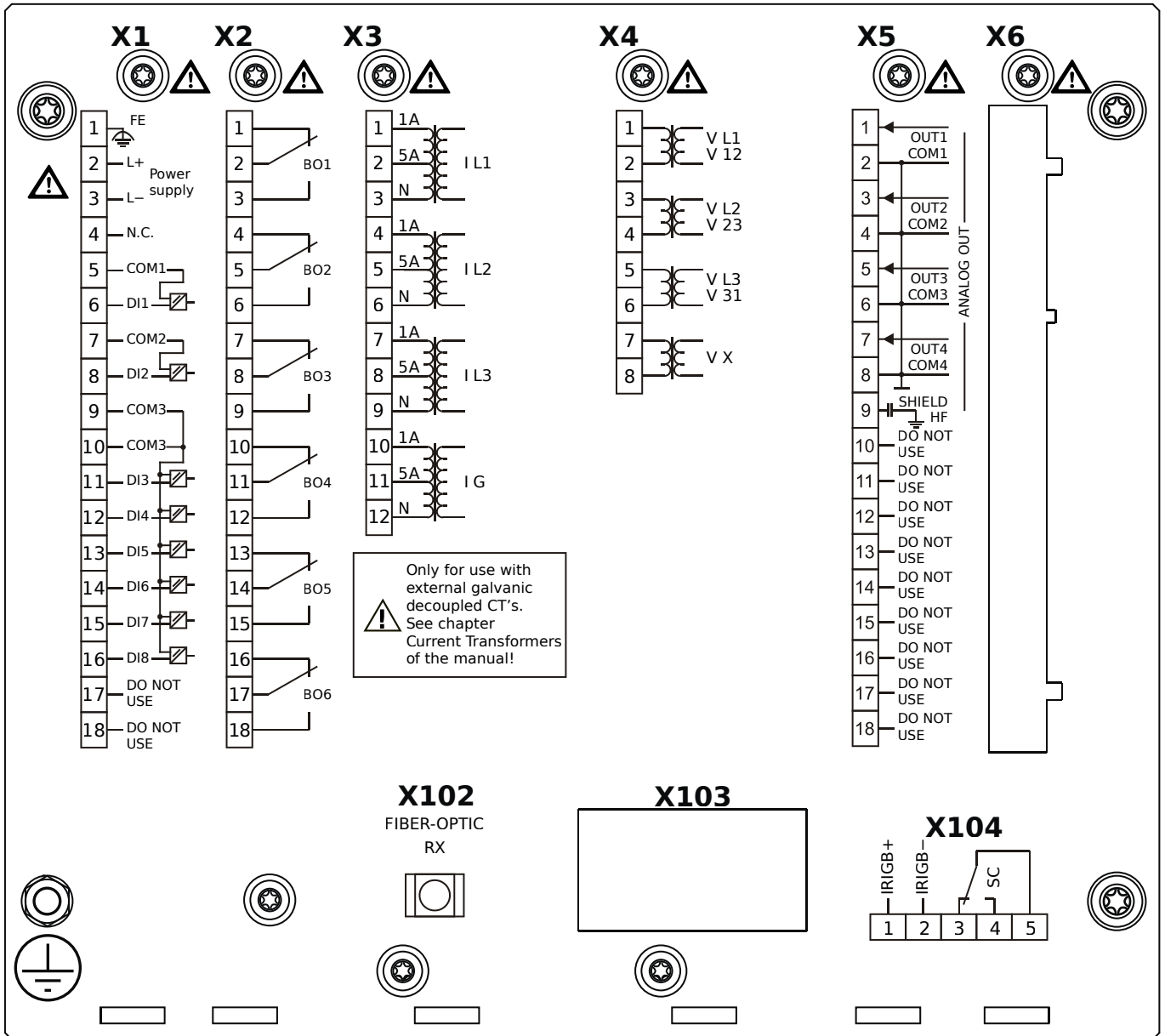

## Housing B2, small display, door mounting

- + Conformal Coating (for installations in harsh environment)
- X1** – DI8-X1: Wide-range power supply unit, incl. 2 non-grouped digital inputs and 6 grouped digital inputs
- X2** – OR6: Assembly Group with 6 Output Relays (Changeover / Form C)
- X3** – TI: Standard current measuring card
- X4** – TU: Card with 4 voltage transformer measuring inputs (0 ... 800 VAC, under UL: 0 ... 600 VAC)
- X5** – AnO4: Analog Outputs
- X102** – Universal Resistance-Temperature Detector (URTD) input, Fiber optics interface, Versatile Link
- X104** – IRIG-B00X, incl. System Contact (Supervision Contact)

# MRMV4-2A0ABA

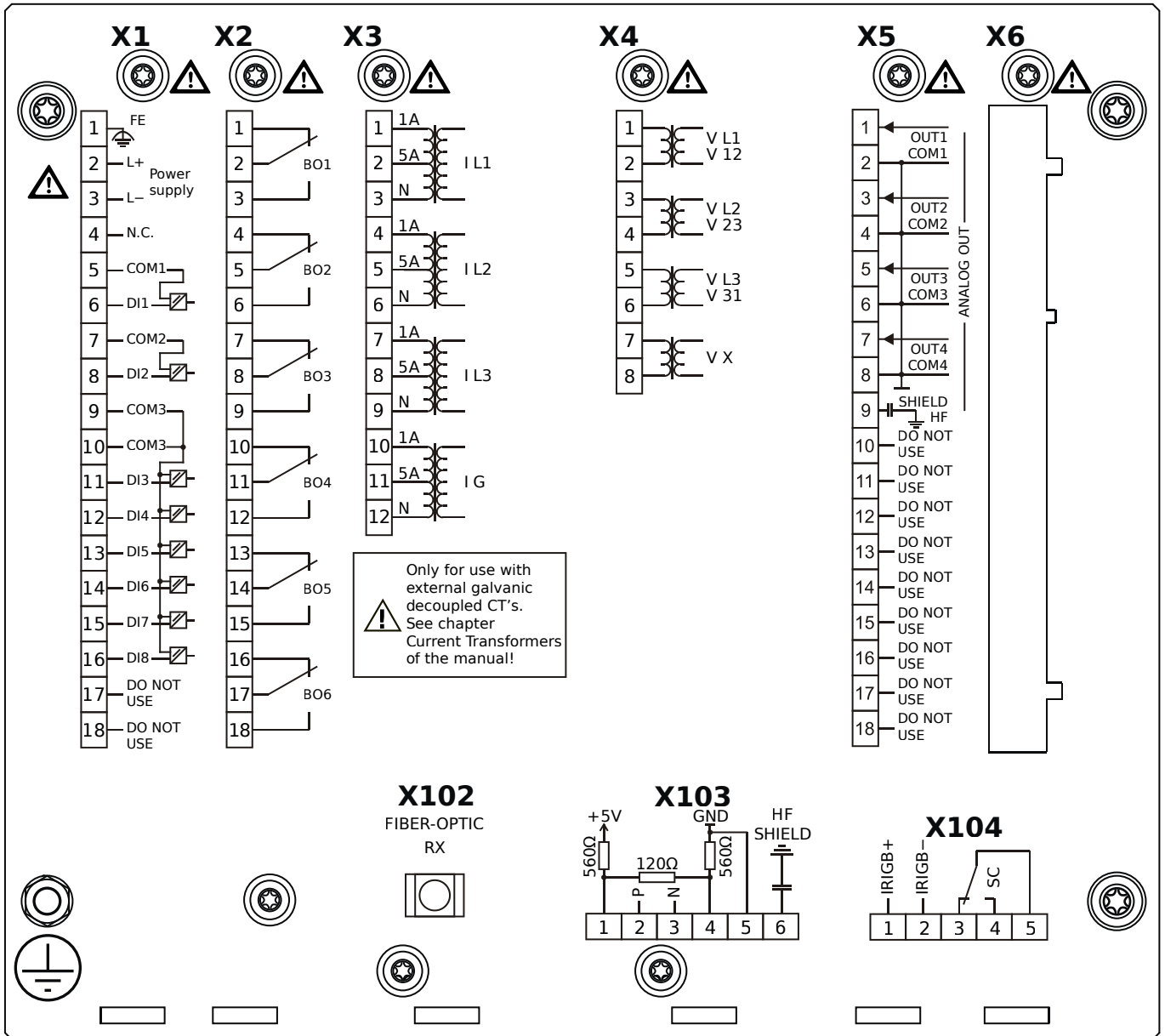

## Housing B2, small display, door mounting

- X1** – DI8-X1: Wide-range power supply unit, incl. 2 non-grouped digital inputs and 6 grouped digital inputs
- X2** – OR6: Assembly Group with 6 Output Relays (Changeover / Form C)
- X3** – TI: Standard current measuring card
- X4** – TU: Card with 4 voltage transformer measuring inputs (0 ... 800 VAC, under UL: 0 ... 600 VAC)
- X5** – AnO4: Analog Outputs
- X102** – Universal Resistance-Temperature Detector (URTD) input, Fiber optics interface, Versatile Link
- X103** – Modbus RTU / IEC 60870-5-103 / DNP3.0 RTU, RS485, Terminals
- X104** – IRIG-B00X, incl. System Contact (Supervision Contact)

# MRMV4-2A0ABB

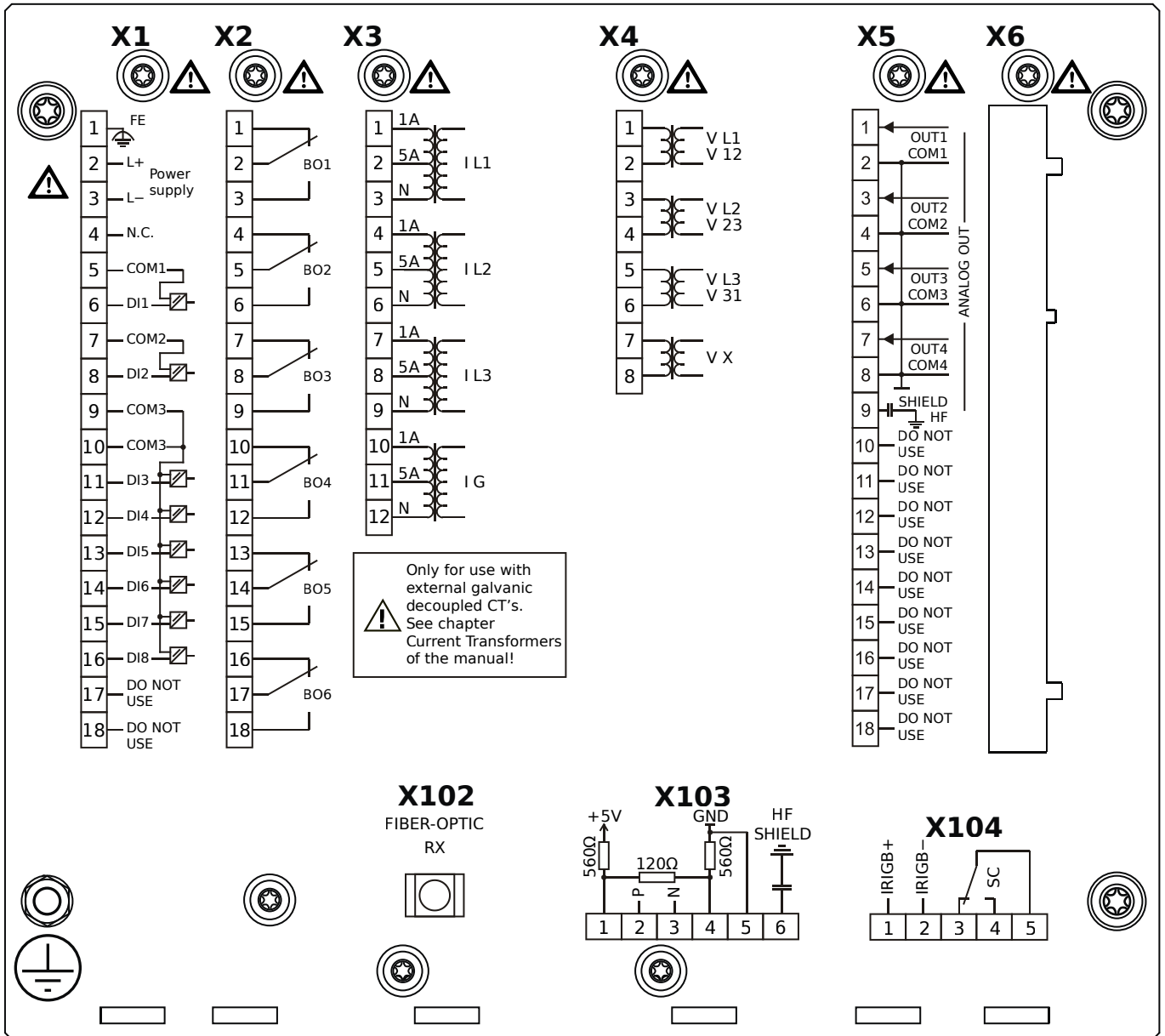

## Housing B2, small display, door mounting

+ Conformal Coating (for installations in harsh environment)

- X1** – DI8-X1: Wide-range power supply unit, incl. 2 non-grouped digital inputs and 6 grouped digital inputs
- X2** – OR6: Assembly Group with 6 Output Relays (Changeover / Form C)
- X3** – TI: Standard current measuring card
- X4** – TU: Card with 4 voltage transformer measuring inputs (0 ... 800 VAC, under UL: 0 ... 600 VAC)
- X5** – AnO4: Analog Outputs
- X102** – Universal Resistance-Temperature Detector (URTD) input, Fiber optics interface, Versatile Link
- X103** – Modbus RTU / IEC 60870-5-103 / DNP3.0 RTU, RS485, Terminals
- X104** – IRIG-B00X, incl. System Contact (Supervision Contact)

# MRMV4-2A0ACA

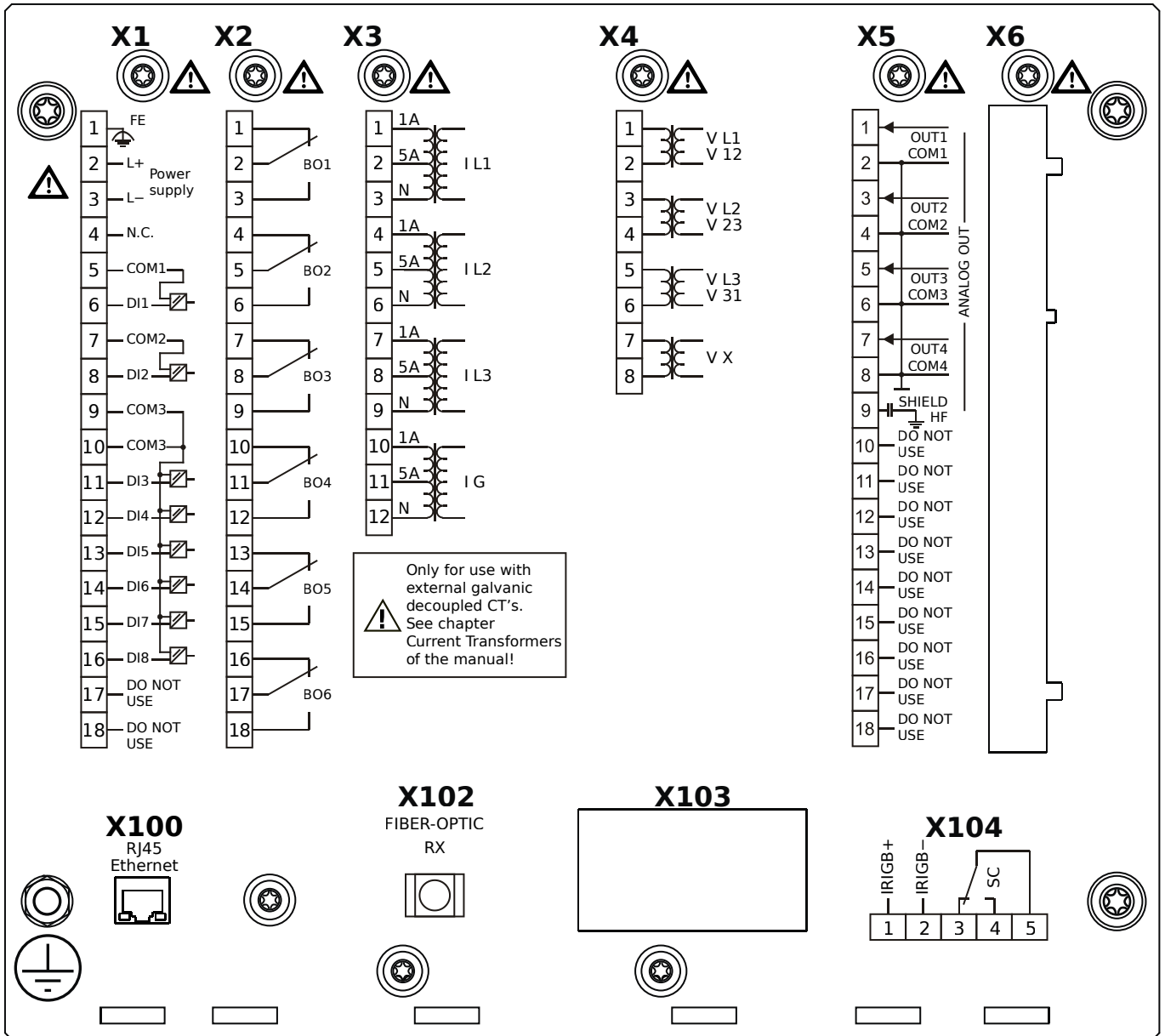

## Housing B2, small display, door mounting

- X1** – DI8-X1: Wide-range power supply unit, incl. 2 non-grouped digital inputs and 6 grouped digital inputs
- X2** – OR6: Assembly Group with 6 Output Relays (Changeover / Form C)
- X3** – TI: Standard current measuring card
- X4** – TU: Card with 4 voltage transformer measuring inputs (0 ... 800 VAC, under UL: 0 ... 600 VAC)
- X5** – AnO4: Analog Outputs
- X100** – Modbus TCP / IEC 60870-5-104 / DNP3.0 TCP/UDP, Ethernet interface, 100 Mbit/s, RJ45 (BASE100-FX)
- X102** – Universal Resistance-Temperature Detector (URTD) input, Fiber optics interface, Versatile Link
- X104** – IRIG-B00X, incl. System Contact (Supervision Contact)

# MRMV4-2A0ACB

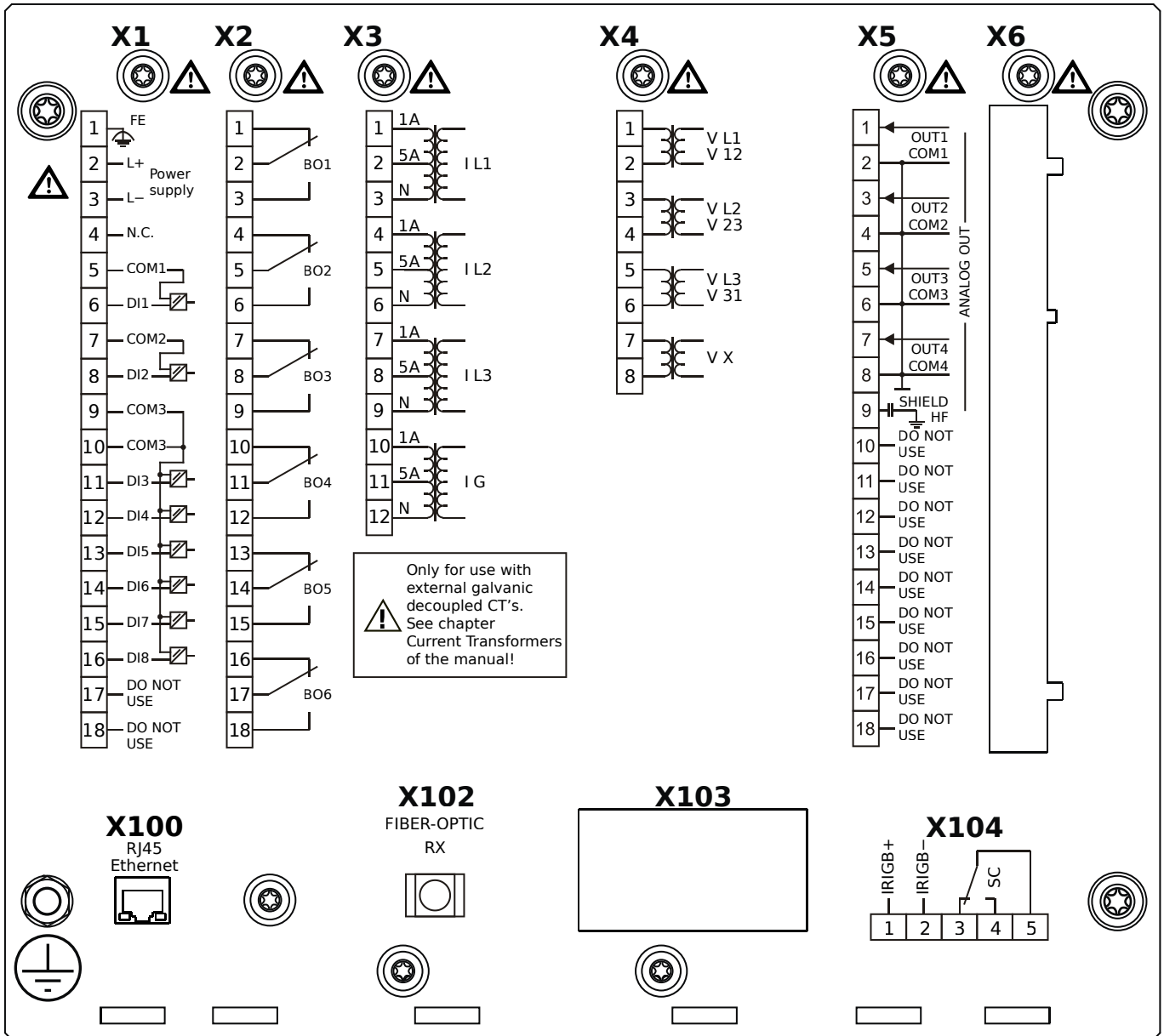

## Housing B2, small display, door mounting

- + Conformal Coating (for installations in harsh environment)

- X1** – DI8-X1: Wide-range power supply unit, incl. 2 non-grouped digital inputs and 6 grouped digital inputs
- X2** – OR6: Assembly Group with 6 Output Relays (Changeover / Form C)
- X3** – TI: Standard current measuring card
- X4** – TU: Card with 4 voltage transformer measuring inputs (0 ... 800 VAC, under UL: 0 ... 600 VAC)
- X5** – AnO4: Analog Outputs
- X100** – Modbus TCP / IEC 60870-5-104 / DNP3.0 TCP/UDP, Ethernet interface, 100 Mbit/s, RJ45 (BASE100-FX)
- X102** – Universal Resistance-Temperature Detector (URTD) input, Fiber optics interface, Versatile Link
- X104** – IRIG-B00X, incl. System Contact (Supervision Contact)

# MRMV4-2A0ADA

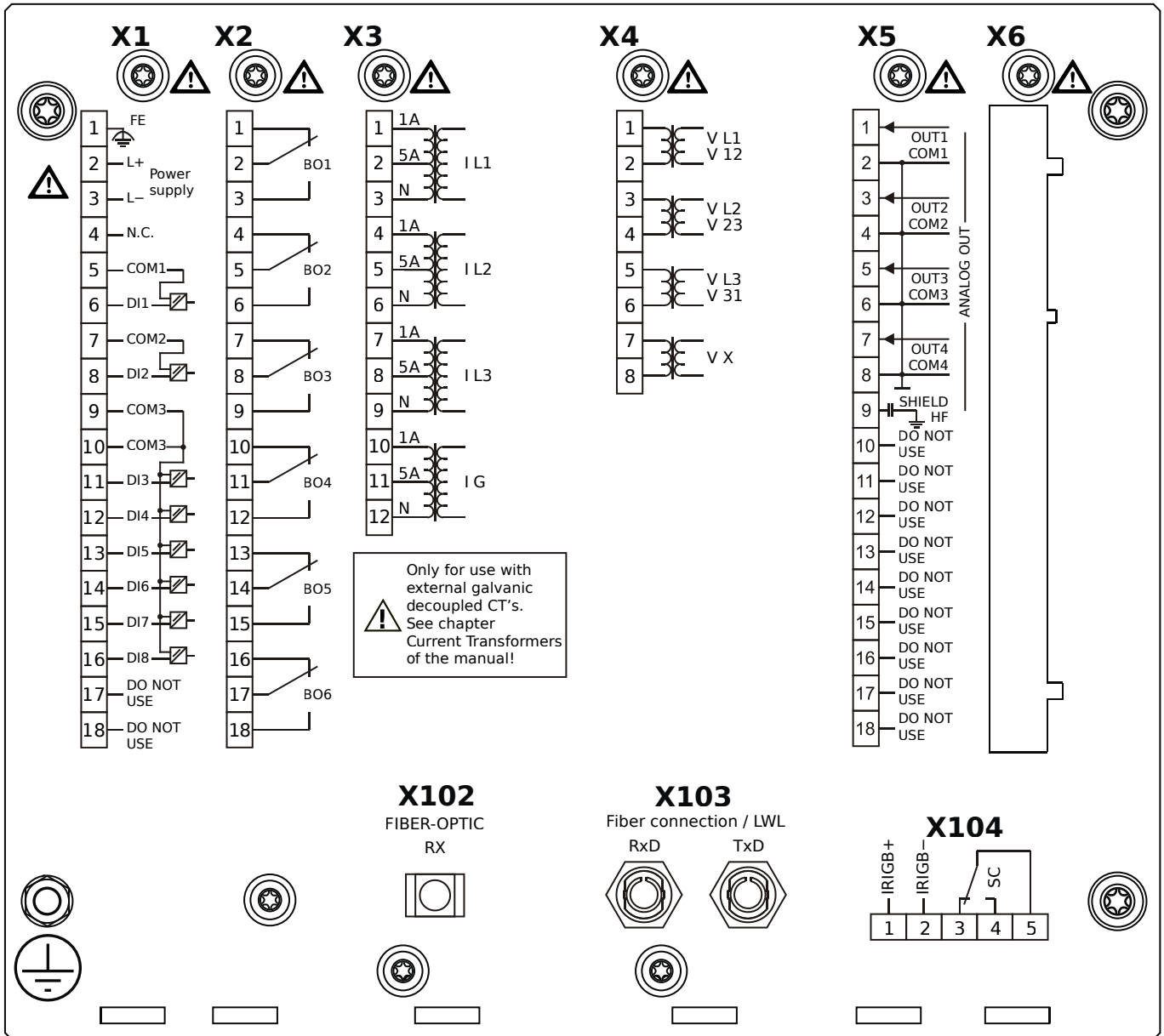

## Housing B2, small display, door mounting

- X1** – DI8-X1: Wide-range power supply unit, incl. 2 non-grouped digital inputs and 6 grouped digital inputs
- X2** – OR6: Assembly Group with 6 Output Relays (Changeover / Form C)
- X3** – TI: Standard current measuring card
- X4** – TU: Card with 4 voltage transformer measuring inputs (0 ... 800 VAC, under UL: 0 ... 600 VAC)
- X5** – AnO4: Analog Outputs
- X102** – Universal Resistance-Temperature Detector (URTD) input, Fiber optics interface, Versatile Link
- X103** – Profibus-DP, Fiber optics interface, ST Connector
- X104** – IRIG-B00X, incl. System Contact (Supervision Contact)



# MRMV4-2A0ADB

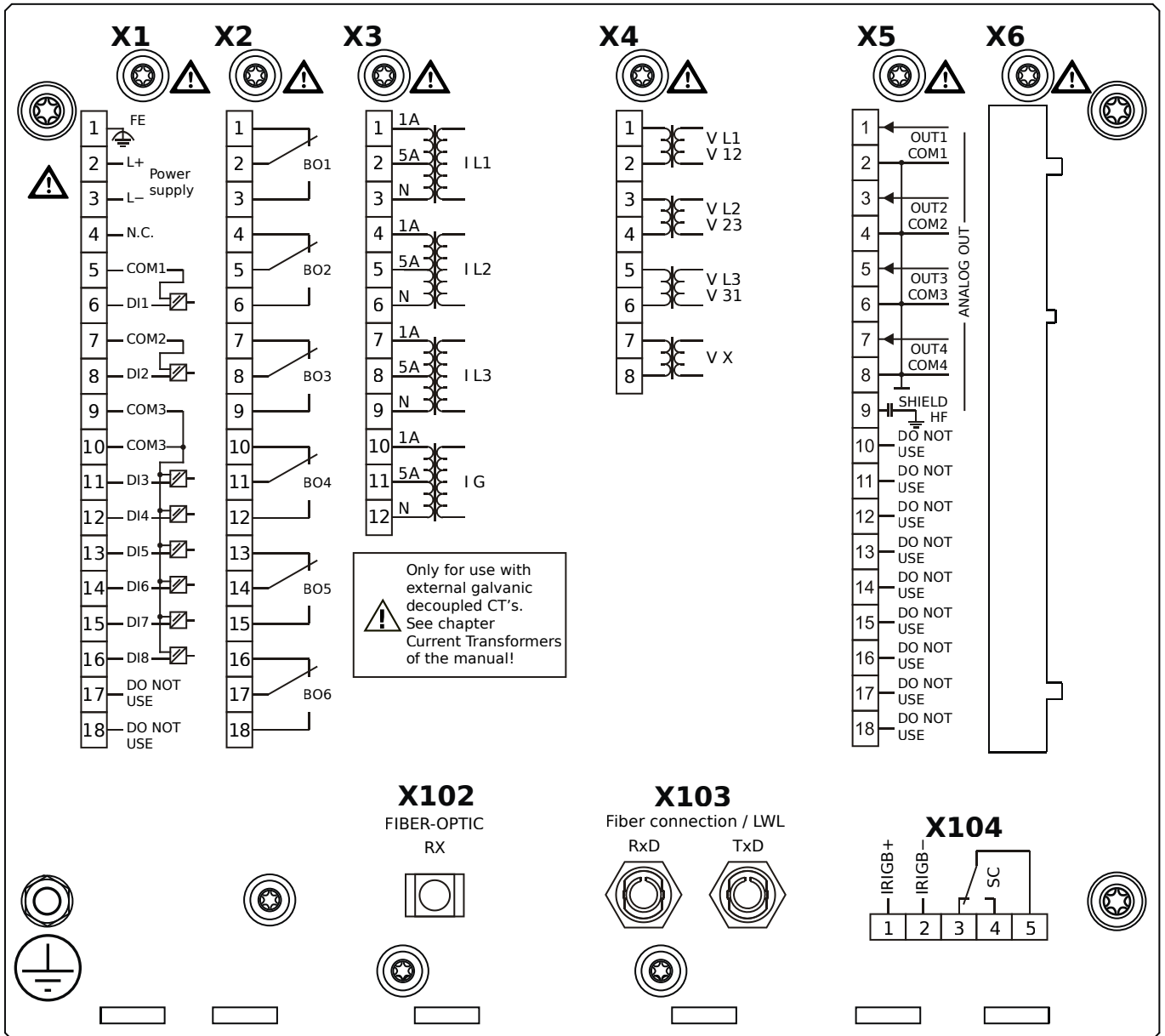

## Housing B2, small display, door mounting

+ Conformal Coating (for installations in harsh environment)

- X1** – DI8-X1: Wide-range power supply unit, incl. 2 non-grouped digital inputs and 6 grouped digital inputs
- X2** – OR6: Assembly Group with 6 Output Relays (Changeover / Form C)
- X3** – TI: Standard current measuring card
- X4** – TU: Card with 4 voltage transformer measuring inputs (0 ... 800 VAC, under UL: 0 ... 600 VAC)
- X5** – AnO4: Analog Outputs
- X102** – Universal Resistance-Temperature Detector (URTD) input, Fiber optics interface, Versatile Link
- X103** – Profibus-DP, Fiber optics interface, ST Connector
- X104** – IRIG-B00X, incl. System Contact (Supervision Contact)

# MRMV4-2A0AEA

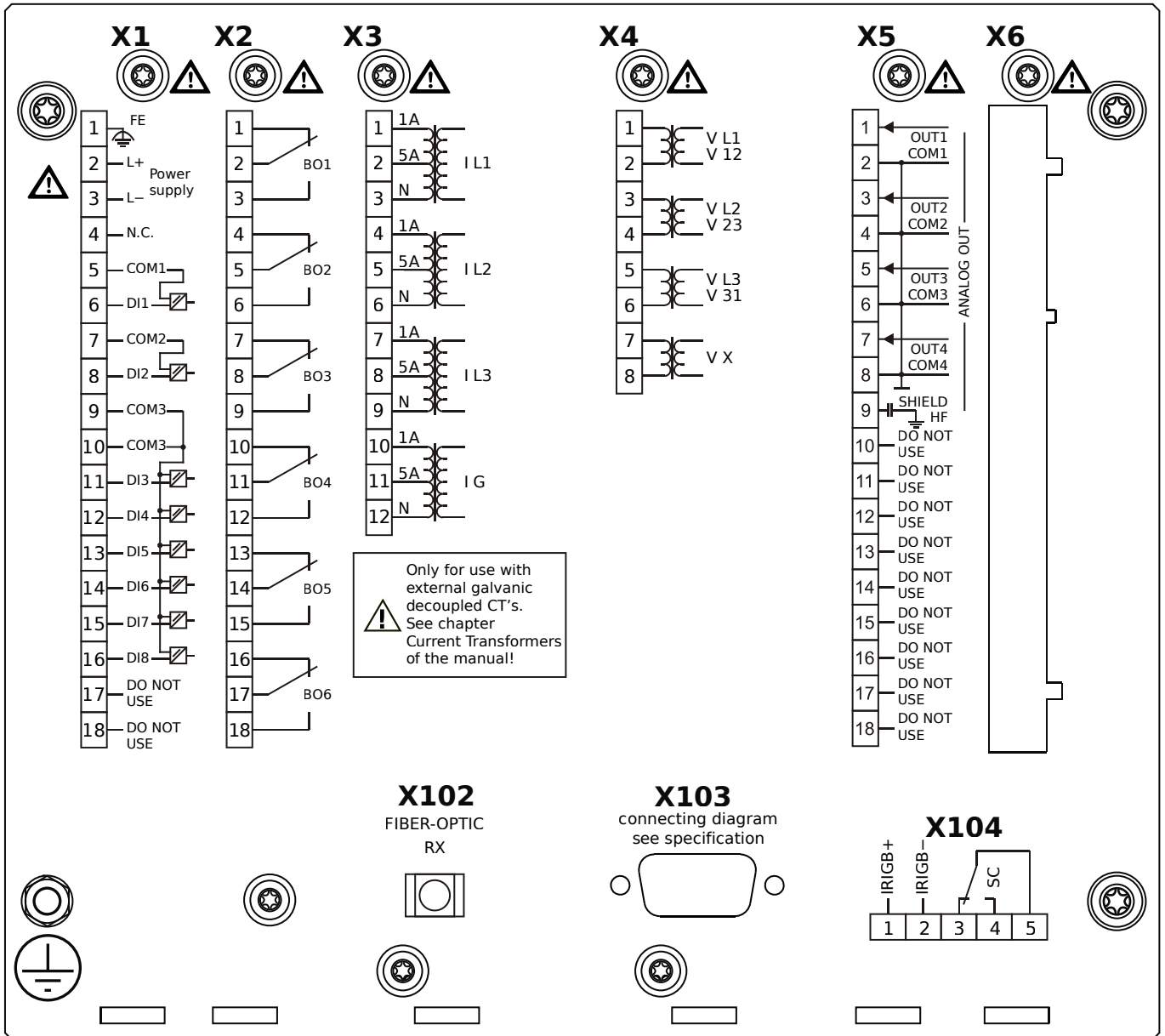

## Housing B2, small display, door mounting

- X1** – DI8-X1: Wide-range power supply unit, incl. 2 non-grouped digital inputs and 6 grouped digital inputs
- X2** – OR6: Assembly Group with 6 Output Relays (Changeover / Form C)
- X3** – TI: Standard current measuring card
- X4** – TU: Card with 4 voltage transformer measuring inputs (0 ... 800 VAC, under UL: 0 ... 600 VAC)
- X5** – AnO4: Analog Outputs
- X102** – Universal Resistance-Temperature Detector (URTD) input, Fiber optics interface, Versatile Link
- X103** – Profibus-DP, RS485, D-SUB
- X104** – IRIG-B00X, incl. System Contact (Supervision Contact)

# MRMV4-2A0AEB

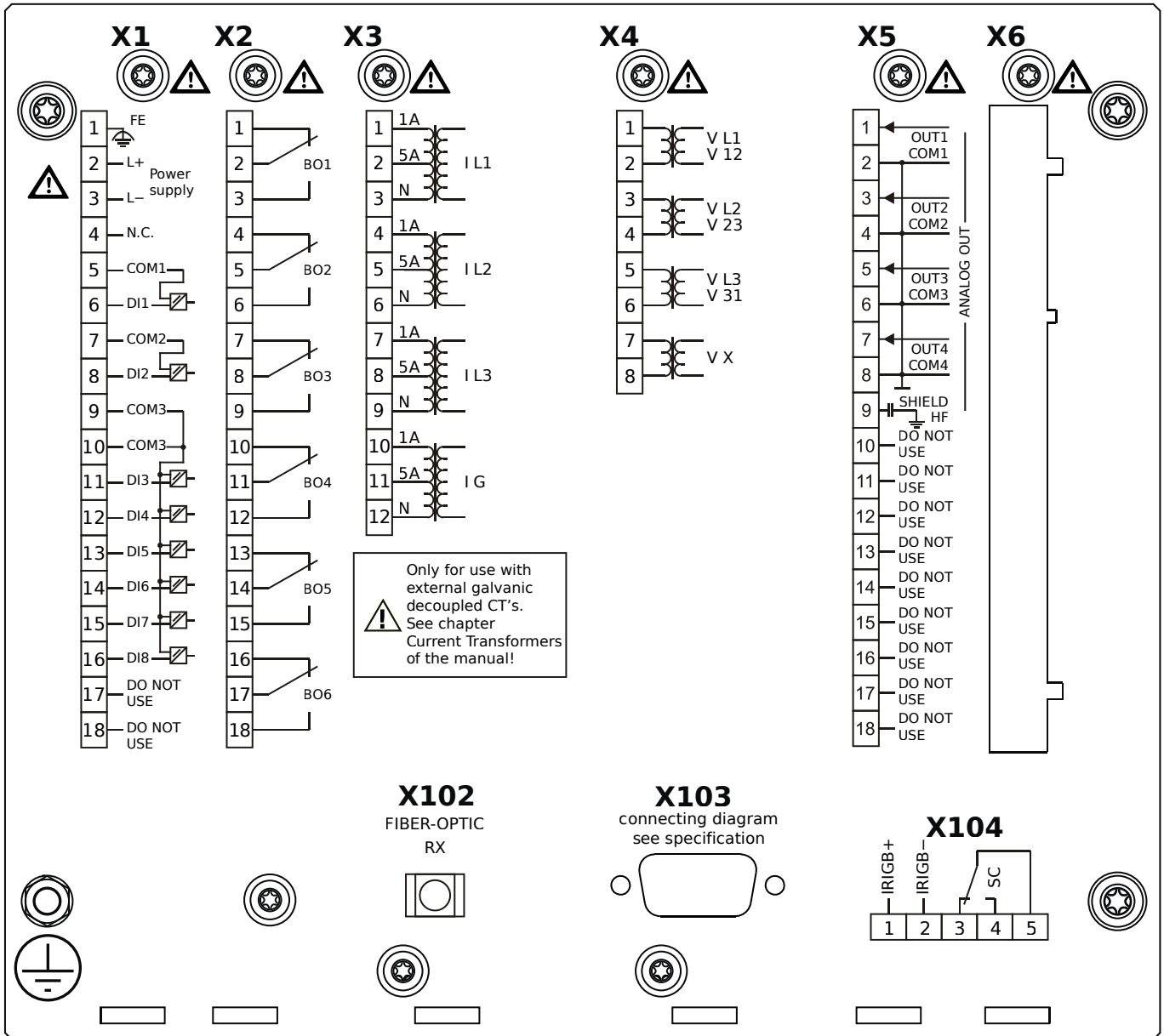

## Housing B2, small display, door mounting

+ Conformal Coating (for installations in harsh environment)

- X1** – DI8-X1: Wide-range power supply unit, incl. 2 non-grouped digital inputs and 6 grouped digital inputs
- X2** – OR6: Assembly Group with 6 Output Relays (Changeover / Form C)
- X3** – TI: Standard current measuring card
- X4** – TU: Card with 4 voltage transformer measuring inputs (0 ... 800 VAC, under UL: 0 ... 600 VAC)
- X5** – AnO4: Analog Outputs
- X102** – Universal Resistance-Temperature Detector (URTD) input, Fiber optics interface, Versatile Link
- X103** – Profibus-DP, RS485, D-SUB
- X104** – IRIG-B00X, incl. System Contact (Supervision Contact)

# MRMV4-2A0AFA

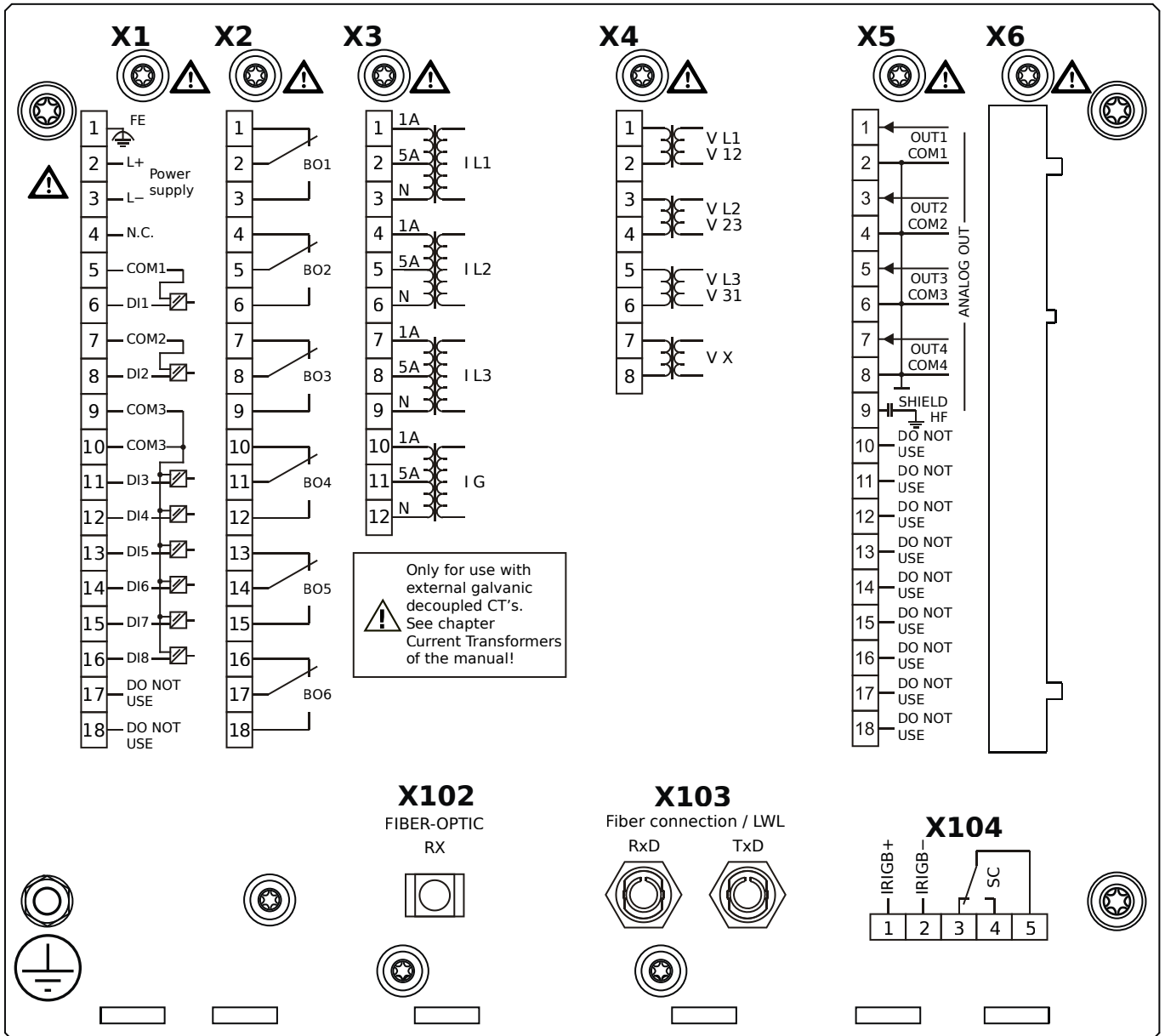

## Housing B2, small display, door mounting

- X1** – DI8-X1: Wide-range power supply unit, incl. 2 non-grouped digital inputs and 6 grouped digital inputs
- X2** – OR6: Assembly Group with 6 Output Relays (Changeover / Form C)
- X3** – TI: Standard current measuring card
- X4** – TU: Card with 4 voltage transformer measuring inputs (0 ... 800 VAC, under UL: 0 ... 600 VAC)
- X5** – AnO4: Analog Outputs
- X102** – Universal Resistance-Temperature Detector (URTD) input, Fiber optics interface, Versatile Link
- X103** – Modbus RTU / IEC 60870-5-103 / DNP3.0 RTU, Fiber optics interface, ST Connector
- X104** – IRIG-B00X, incl. System Contact (Supervision Contact)

# MRMV4-2A0AFB

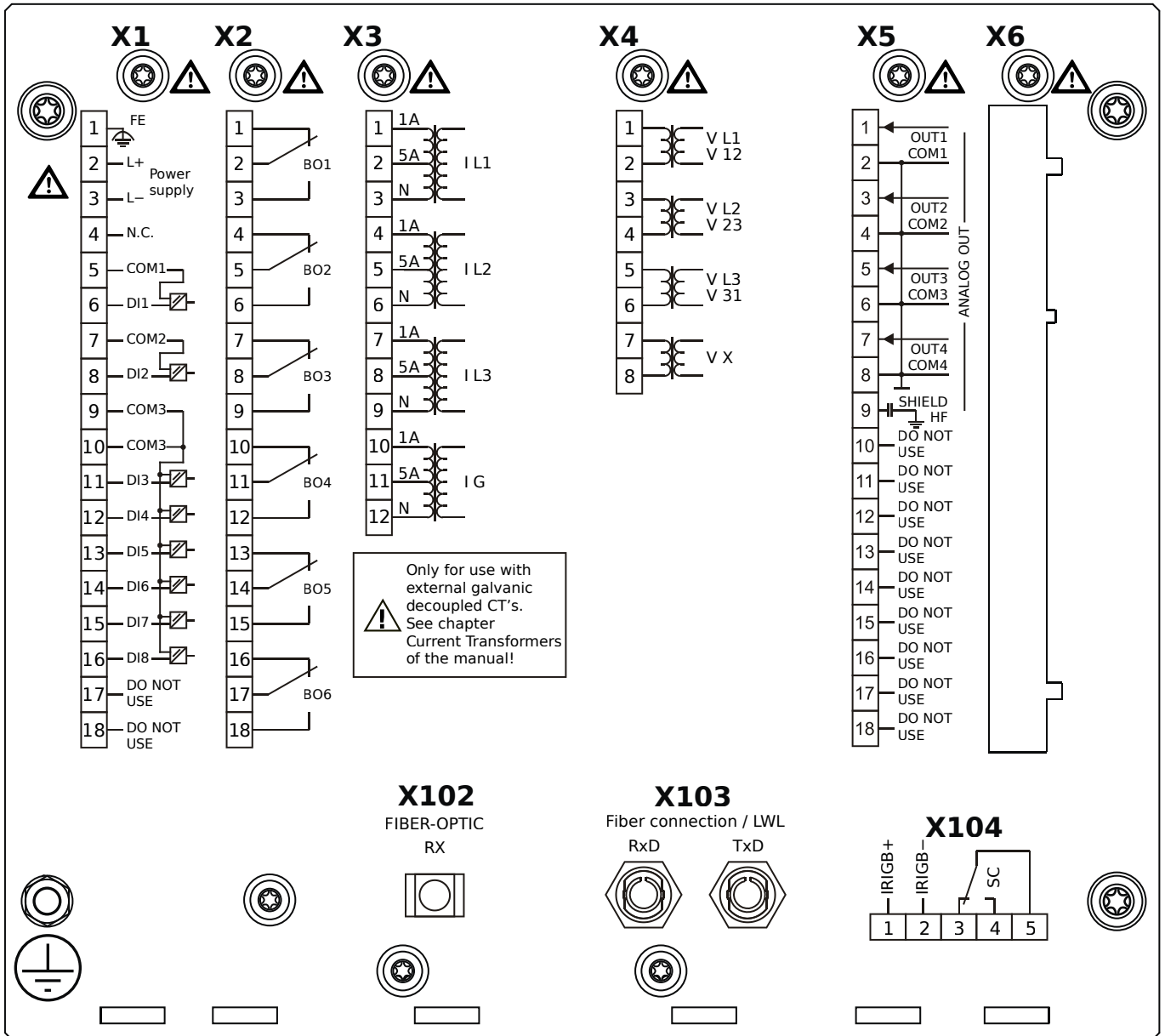

## Housing B2, small display, door mounting

- + Conformal Coating (for installations in harsh environment)

- X1** – DI8-X1: Wide-range power supply unit, incl. 2 non-grouped digital inputs and 6 grouped digital inputs
- X2** – OR6: Assembly Group with 6 Output Relays (Changeover / Form C)
- X3** – TI: Standard current measuring card
- X4** – TU: Card with 4 voltage transformer measuring inputs (0 ... 800 VAC, under UL: 0 ... 600 VAC)
- X5** – AnO4: Analog Outputs
- X102** – Universal Resistance-Temperature Detector (URTD) input, Fiber optics interface, Versatile Link
- X103** – Modbus RTU / IEC 60870-5-103 / DNP3.0 RTU, Fiber optics interface, ST Connector
- X104** – IRIG-B00X, incl. System Contact (Supervision Contact)

# MRMV4-2A0AGA

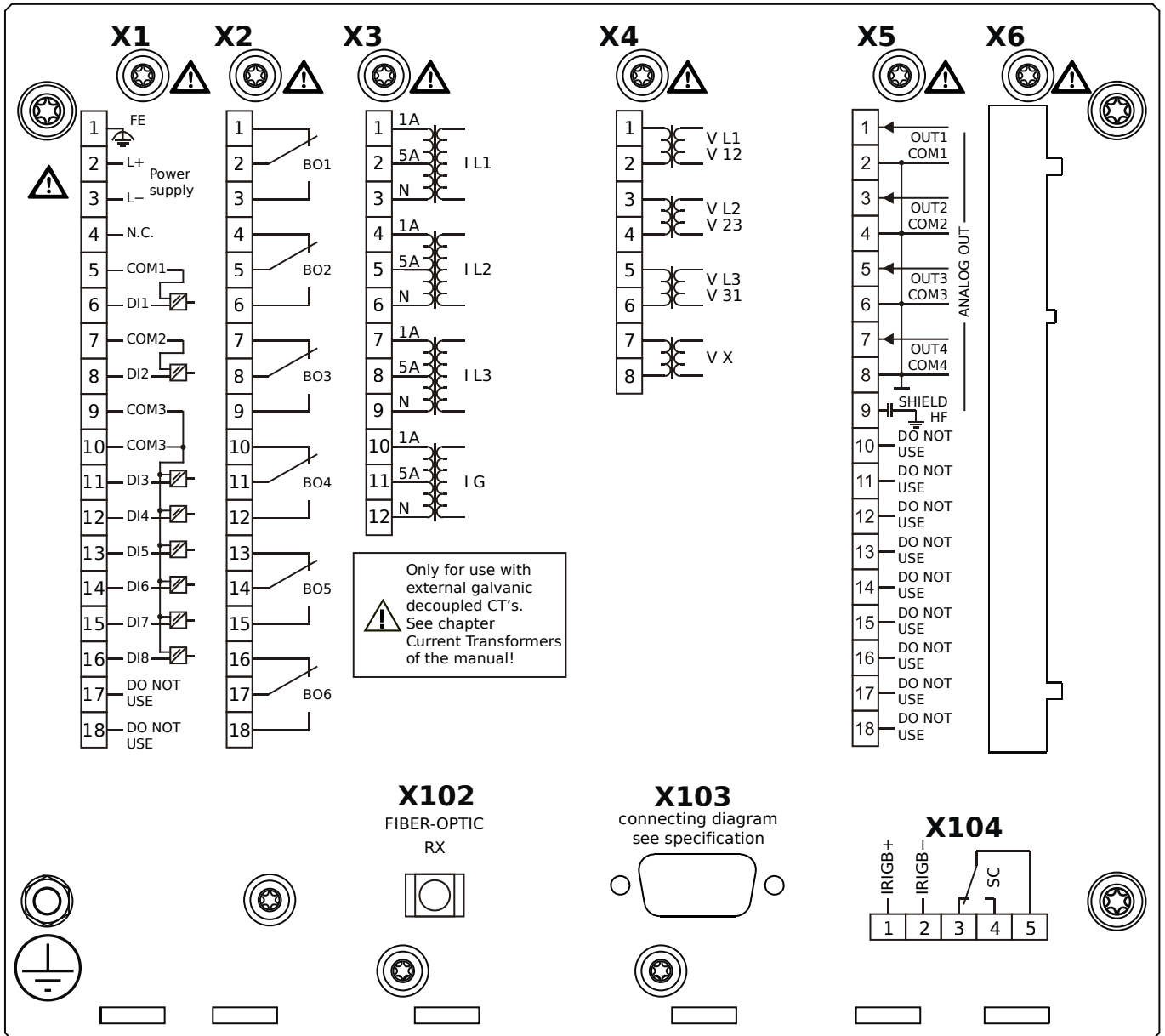

## Housing B2, small display, door mounting

- X1** – DI8-X1: Wide-range power supply unit, incl. 2 non-grouped digital inputs and 6 grouped digital inputs
- X2** – OR6: Assembly Group with 6 Output Relays (Changeover / Form C)
- X3** – TI: Standard current measuring card
- X4** – TU: Card with 4 voltage transformer measuring inputs (0 ... 800 VAC, under UL: 0 ... 600 VAC)
- X5** – AnO4: Analog Outputs
- X102** – Universal Resistance-Temperature Detector (URTD) input, Fiber optics interface, Versatile Link
- X103** – Modbus RTU / IEC 60870-5-103 / DNP3.0 RTU, RS485, D-SUB
- X104** – IRIG-B00X, incl. System Contact (Supervision Contact)

# MRMV4-2A0AGB

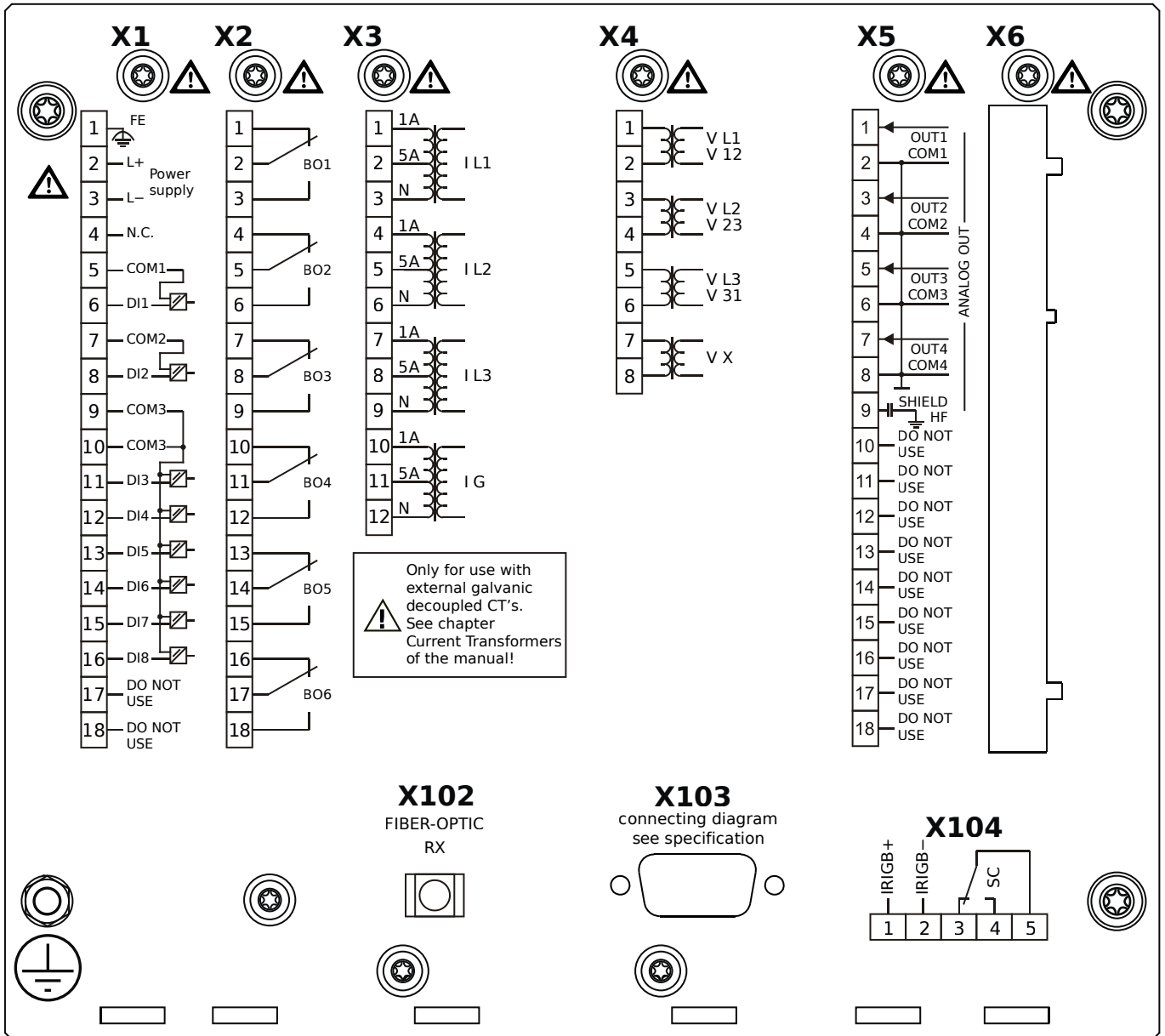

## Housing B2, small display, door mounting

+ Conformal Coating (for installations in harsh environment)

- X1** – DI8-X1: Wide-range power supply unit, incl. 2 non-grouped digital inputs and 6 grouped digital inputs
- X2** – OR6: Assembly Group with 6 Output Relays (Changeover / Form C)
- X3** – TI: Standard current measuring card
- X4** – TU: Card with 4 voltage transformer measuring inputs (0 ... 800 VAC, under UL: 0 ... 600 VAC)
- X5** – AnO4: Analog Outputs
- X102** – Universal Resistance-Temperature Detector (URTD) input, Fiber optics interface, Versatile Link
- X103** – Modbus RTU / IEC 60870-5-103 / DNP3.0 RTU, RS485, D-SUB
- X104** – IRIG-B00X, incl. System Contact (Supervision Contact)

# MRMV4-2A0AHA

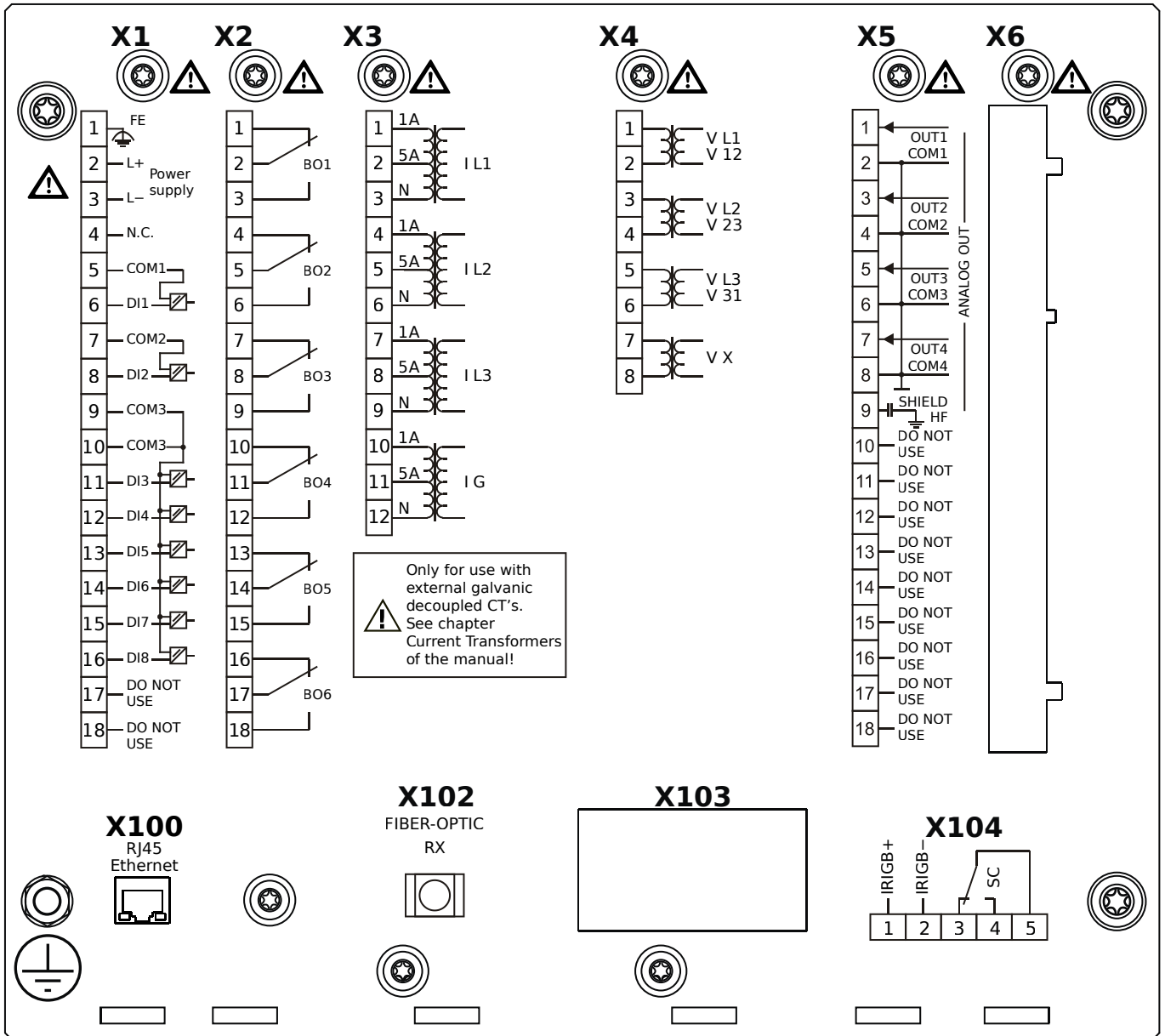

## Housing B2, small display, door mounting

- X1** – DI8-X1: Wide-range power supply unit, incl. 2 non-grouped digital inputs and 6 grouped digital inputs
- X2** – OR6: Assembly Group with 6 Output Relays (Changeover / Form C)
- X3** – TI: Standard current measuring card
- X4** – TU: Card with 4 voltage transformer measuring inputs (0 ... 800 VAC, under UL: 0 ... 600 VAC)
- X5** – AnO4: Analog Outputs
- X100** – IEC 61850 / Modbus TCP / IEC 60870-5-104 / DNP3.0 TCP/UDP, Ethernet interface, 100 Mbit/s, RJ45 (BASE100-
- X102** – Universal Resistance-Temperature Detector (URTD) input, Fiber optics interface, Versatile Link
- X104** – IRIG-B00X, incl. System Contact (Supervision Contact)

FX)



# MRMV4-2A0AHB

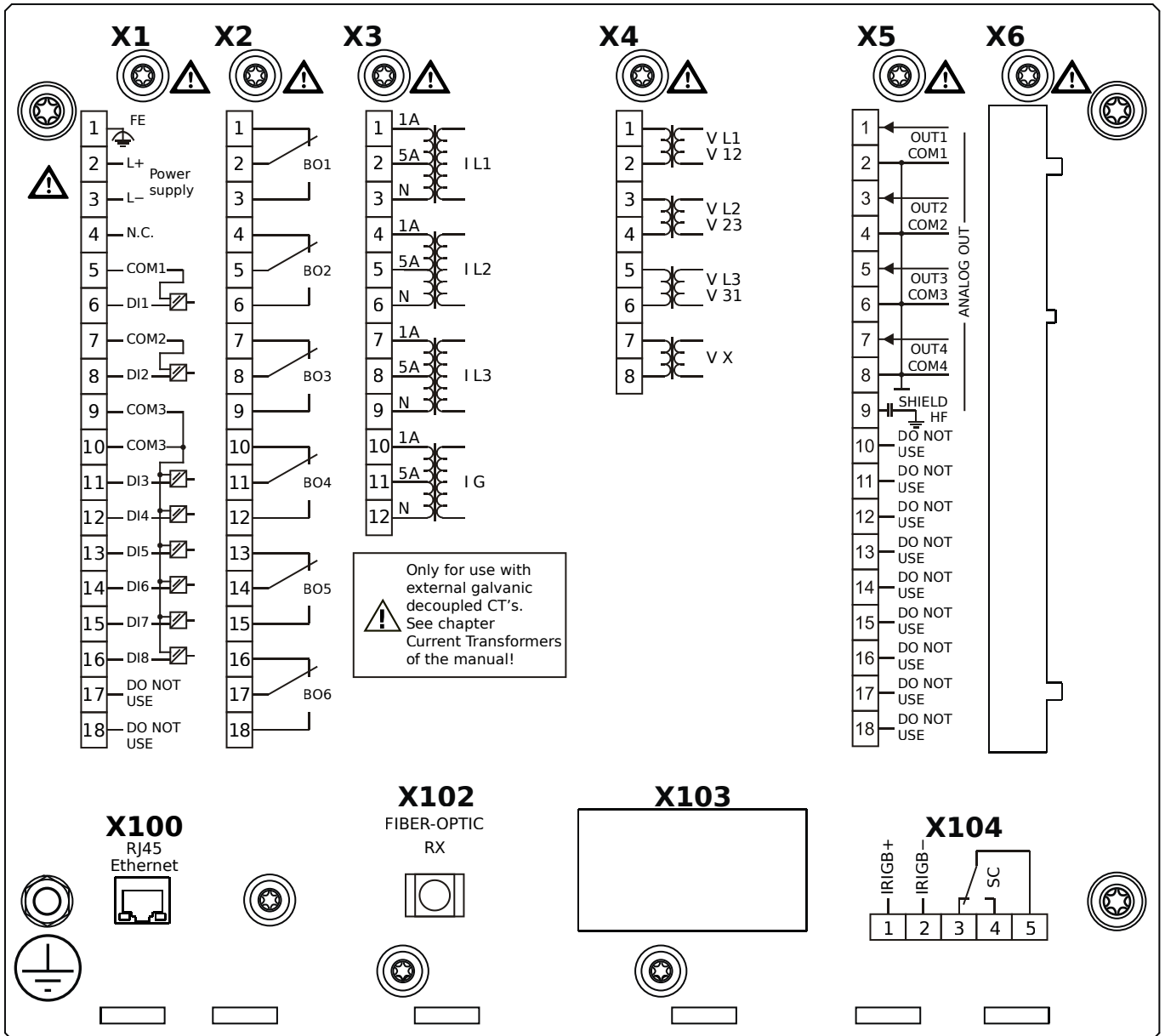

## Housing B2, small display, door mounting

+ Conformal Coating (for installations in harsh environment)

**X1** – DI8-X1: Wide-range power supply unit, incl. 2 non-grouped digital inputs and 6 grouped digital inputs

**X2** – OR6: Assembly Group with 6 Output Relays (Changeover / Form C)

**X3** – TI: Standard current measuring card

**X4** – TU: Card with 4 voltage transformer measuring inputs (0 ... 800 VAC, under UL: 0 ... 600 VAC)

**X5** – AnO4: Analog Outputs

**X100** – IEC 61850 / Modbus TCP / IEC 60870-5-104 / DNP3.0 TCP/UDP, Ethernet interface, 100 Mbit/s, RJ45 (BASE100-

FX)

**X102** – Universal Resistance-Temperature Detector (URTD) input, Fiber optics interface, Versatile Link

**X104** – IRIG-B00X, incl. System Contact (Supervision Contact)

# MRMV4-2A0AIA

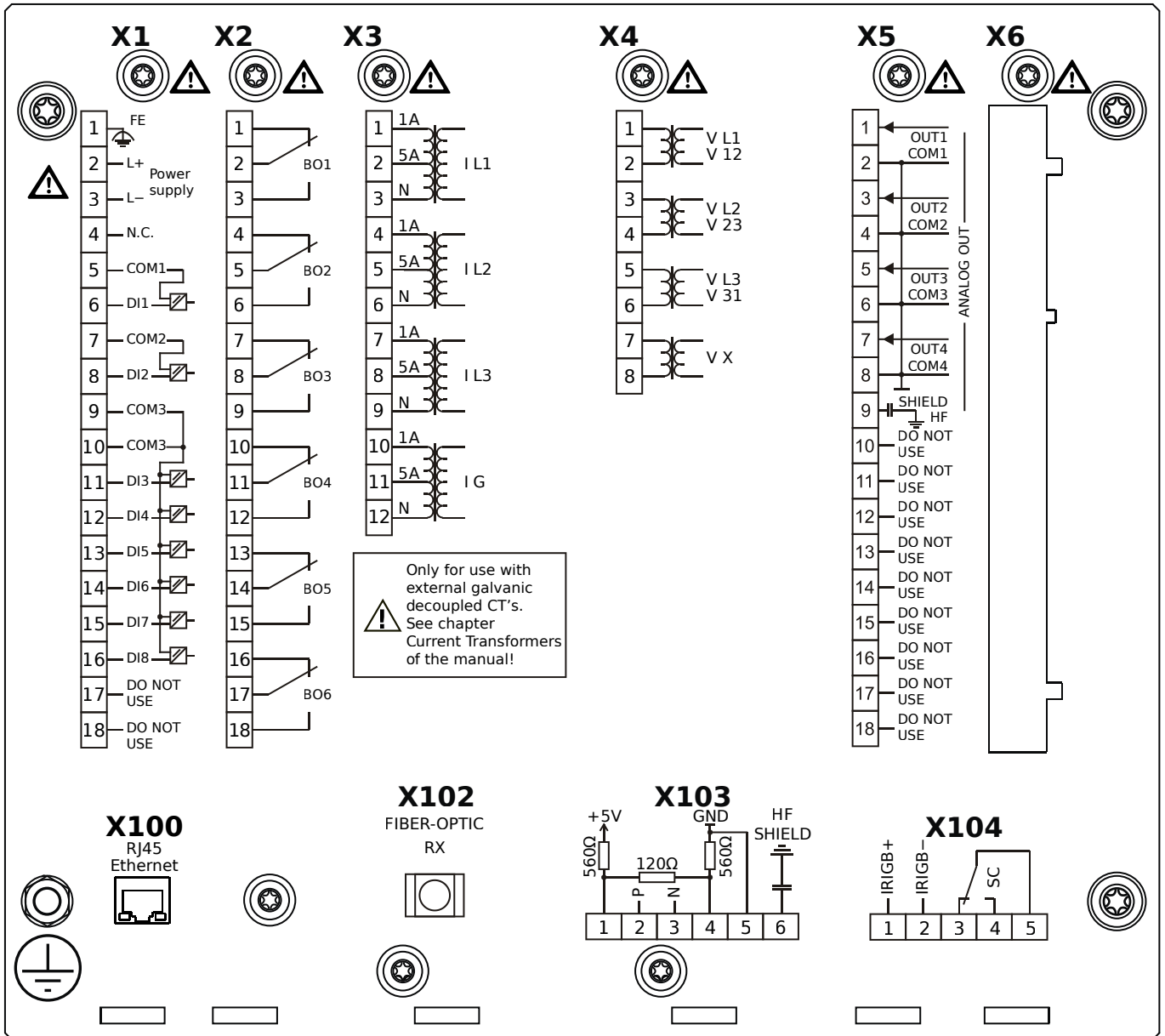

## Housing B2, small display, door mounting

- X1** – DI8-X1: Wide-range power supply unit, incl. 2 non-grouped digital inputs and 6 grouped digital inputs
- X2** – OR6: Assembly Group with 6 Output Relays (Changeover / Form C)
- X3** – TI: Standard current measuring card
- X4** – TU: Card with 4 voltage transformer measuring inputs (0 ... 800 VAC, under UL: 0 ... 600 VAC)
- X5** – AnO4: Analog Outputs
- X100** – Modbus TCP / IEC 60870-5-104 / DNP3.0 TCP/UDP, Ethernet interface, 100 Mbit/s, RJ45 (BASE100-FX)
- X102** – Universal Resistance-Temperature Detector (URTD) input, Fiber optics interface, Versatile Link
- X103** – IEC 60870-5-103 / Modbus RTU / DNP3.0 RTU, RS485, Terminals
- X104** – IRIG-B00X, incl. System Contact (Supervision Contact)

# MRMV4-2A0AIB

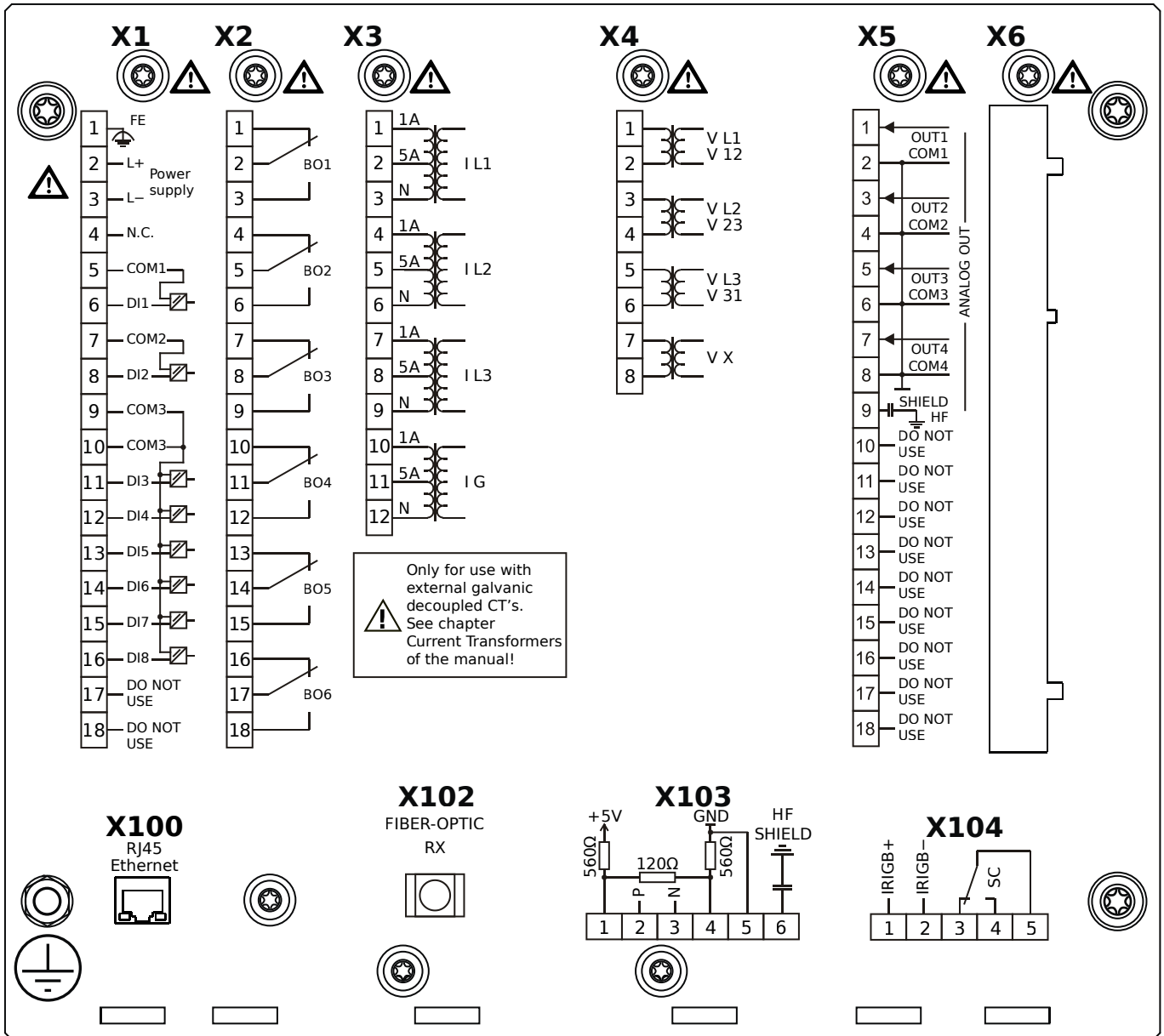

## Housing B2, small display, door mounting

- + Conformal Coating (for installations in harsh environment)

- X1** – DI8-X1: Wide-range power supply unit, incl. 2 non-grouped digital inputs and 6 grouped digital inputs
- X2** – OR6: Assembly Group with 6 Output Relays (Changeover / Form C)
- X3** – TI: Standard current measuring card
- X4** – TU: Card with 4 voltage transformer measuring inputs (0 ... 800 VAC, under UL: 0 ... 600 VAC)
- X5** – AnO4: Analog Outputs
- X100** – Modbus TCP / IEC 60870-5-104 / DNP3.0 TCP/UDP, Ethernet interface, 100 Mbit/s, RJ45 (BASE100-FX)
- X102** – Universal Resistance-Temperature Detector (URTD) input, Fiber optics interface, Versatile Link
- X103** – IEC 60870-5-103 / Modbus RTU / DNP3.0 RTU, RS485, Terminals
- X104** – IRIG-B00X, incl. System Contact (Supervision Contact)

# MRMV4-2A0AKA

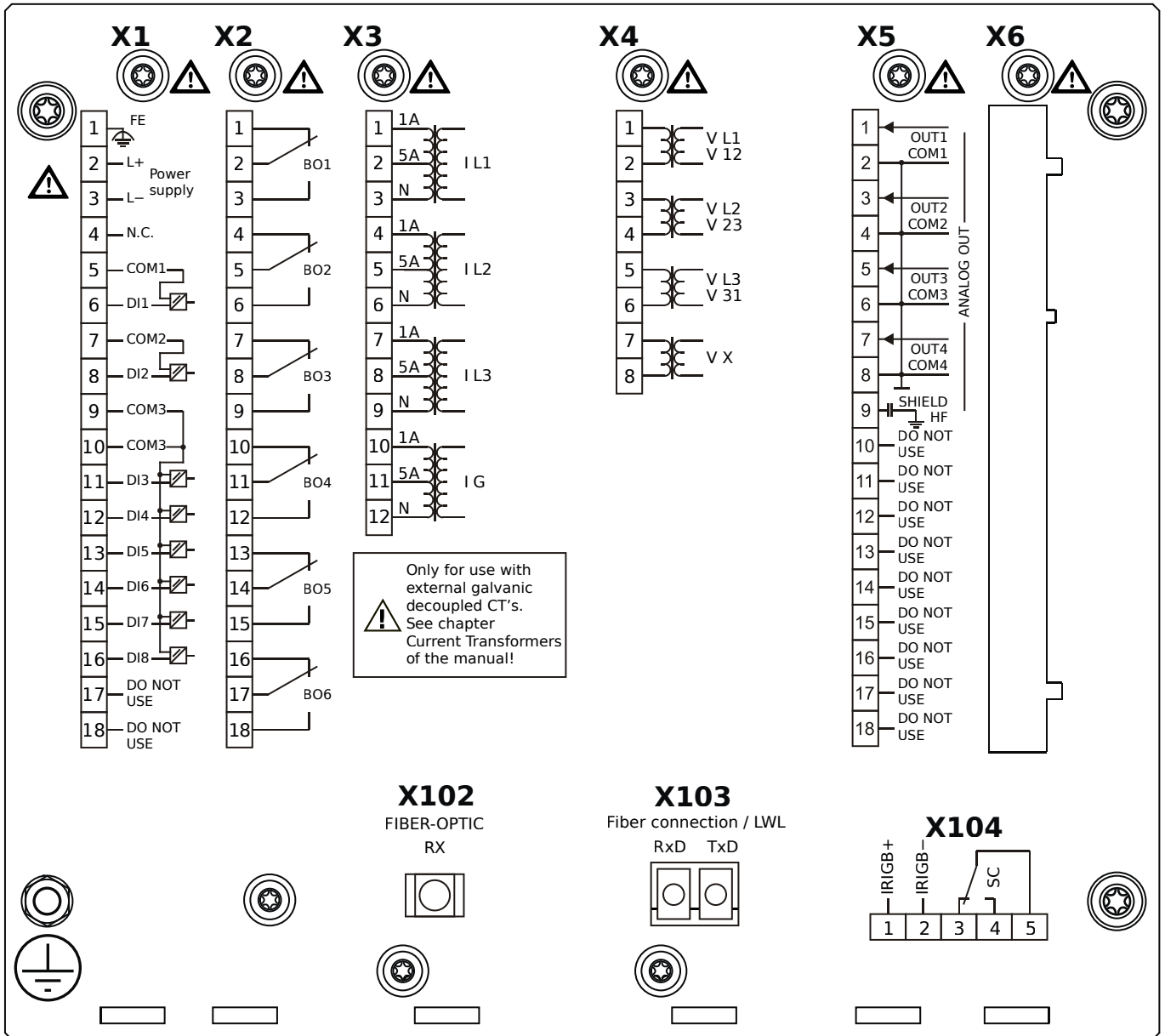

## Housing B2, small display, door mounting

- X1** – DI8-X1: Wide-range power supply unit, incl. 2 non-grouped digital inputs and 6 grouped digital inputs
- X2** – OR6: Assembly Group with 6 Output Relays (Changeover / Form C)
- X3** – TI: Standard current measuring card
- X4** – TU: Card with 4 voltage transformer measuring inputs (0 ... 800 VAC, under UL: 0 ... 600 VAC)
- X5** – AnO4: Analog Outputs
- X102** – Universal Resistance-Temperature Detector (URTD) input, Fiber optics interface, Versatile Link
- X103** – IEC 61850 / Modbus TCP / IEC 60870-5-104 / DNP3.0 TCP/UDP, Fiber optics interface, LC Connector
- X104** – IRIG-B00X, incl. System Contact (Supervision Contact)

# MRMV4-2A0AKB

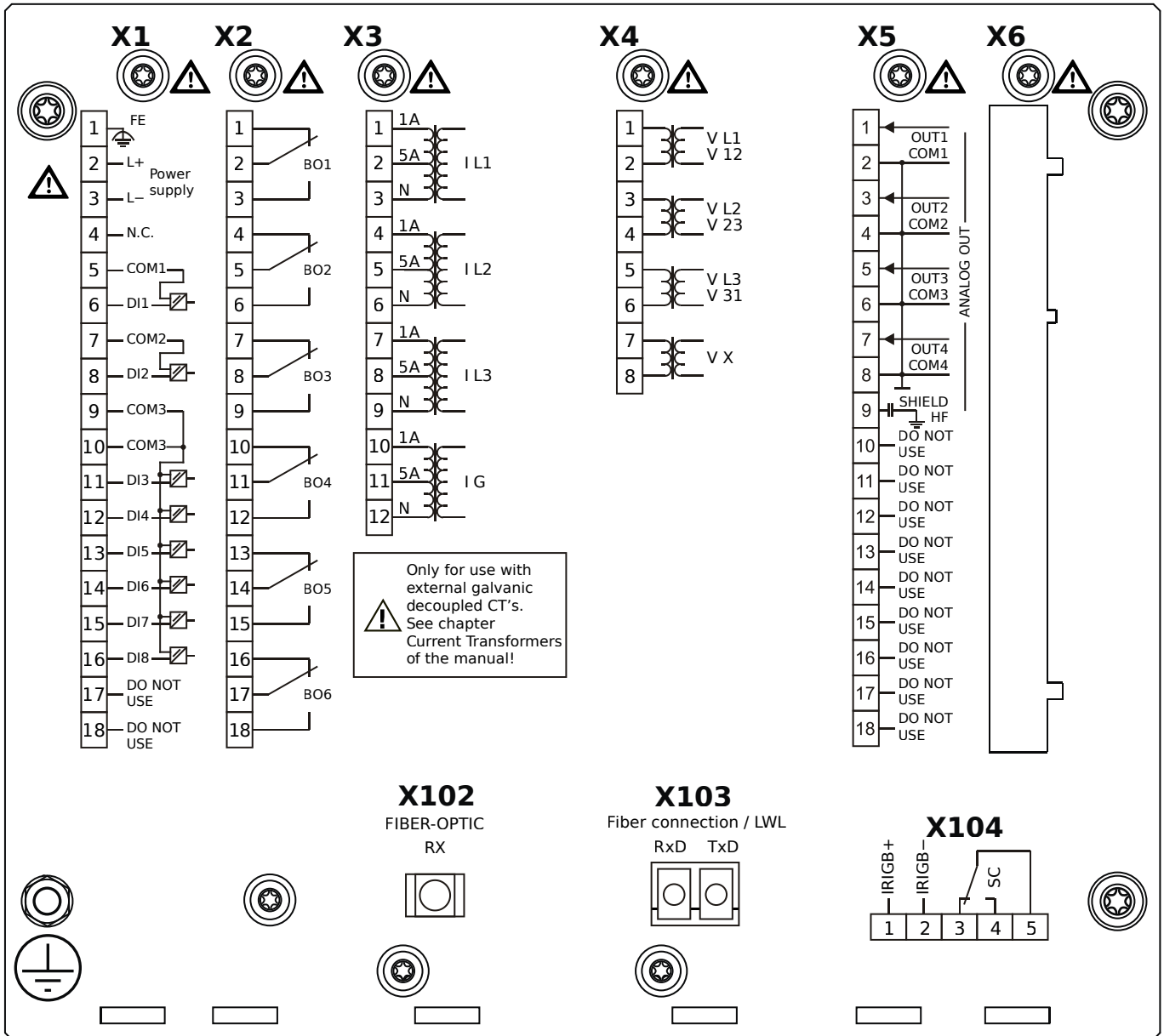

## Housing B2, small display, door mounting

- + Conformal Coating (for installations in harsh environment)

- X1** – DI8-X1: Wide-range power supply unit, incl. 2 non-grouped digital inputs and 6 grouped digital inputs
- X2** – OR6: Assembly Group with 6 Output Relays (Changeover / Form C)
- X3** – TI: Standard current measuring card
- X4** – TU: Card with 4 voltage transformer measuring inputs (0 ... 800 VAC, under UL: 0 ... 600 VAC)
- X5** – AnO4: Analog Outputs
- X102** – Universal Resistance-Temperature Detector (URTD) input, Fiber optics interface, Versatile Link
- X103** – IEC 61850 / Modbus TCP / IEC 60870-5-104 / DNP3.0 TCP/UDP, Fiber optics interface, LC Connector
- X104** – IRIG-B00X, incl. System Contact (Supervision Contact)

# MRMV4-2A0ALA

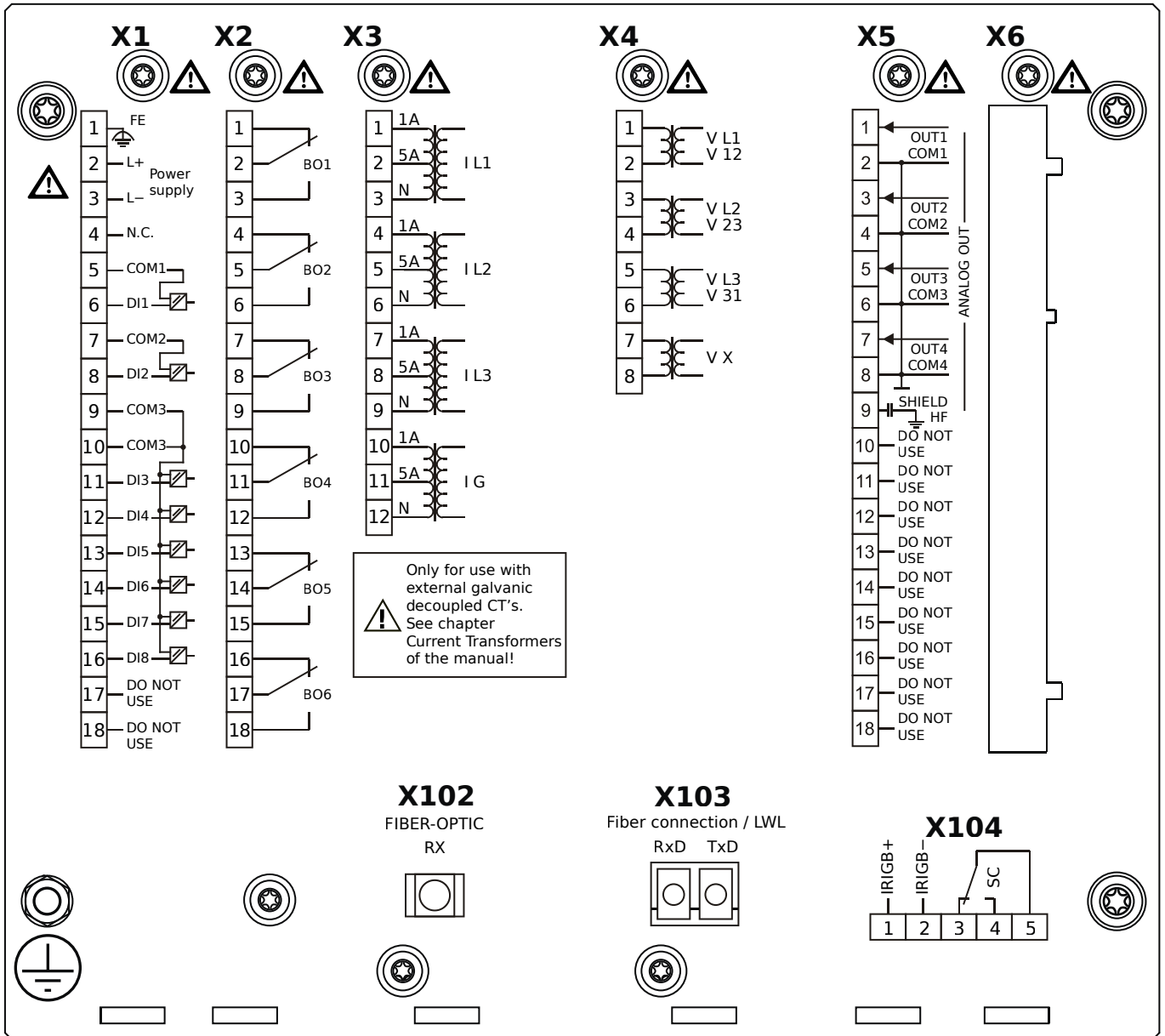

## Housing B2, small display, door mounting

- X1** – DI8-X1: Wide-range power supply unit, incl. 2 non-grouped digital inputs and 6 grouped digital inputs
- X2** – OR6: Assembly Group with 6 Output Relays (Changeover / Form C)
- X3** – TI: Standard current measuring card
- X4** – TU: Card with 4 voltage transformer measuring inputs (0 ... 800 VAC, under UL: 0 ... 600 VAC)
- X5** – AnO4: Analog Outputs
- X102** – Universal Resistance-Temperature Detector (URTD) input, Fiber optics interface, Versatile Link
- X103** – Modbus TCP / IEC 60870-5-104 / DNP3.0 TCP/UDP, Fiber optics interface, LC Connector
- X104** – IRIG-B00X, incl. System Contact (Supervision Contact)

# MRMV4-2A0ALB

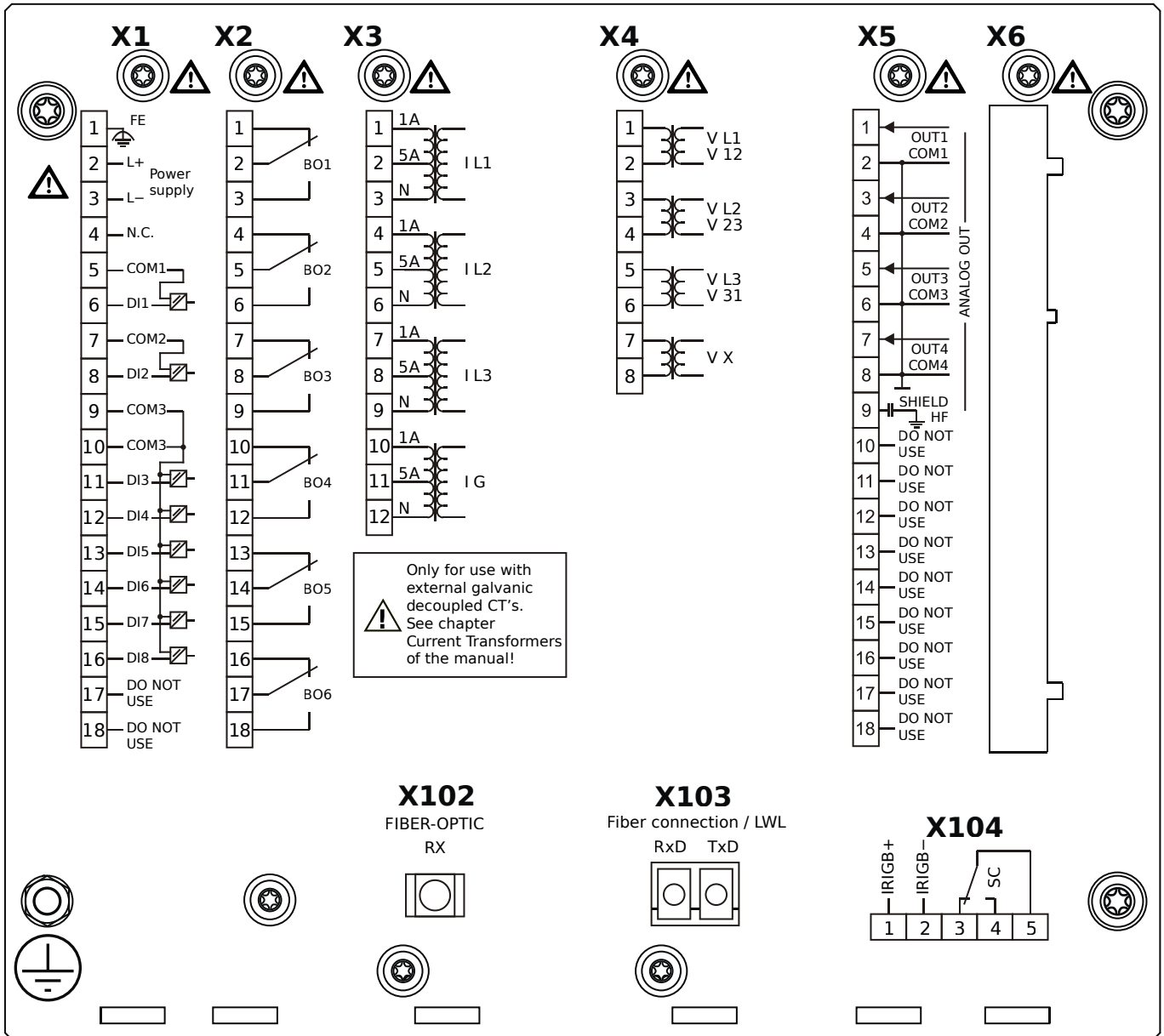

## Housing B2, small display, door mounting

- + Conformal Coating (for installations in harsh environment)

- X1** – DI8-X1: Wide-range power supply unit, incl. 2 non-grouped digital inputs and 6 grouped digital inputs
- X2** – OR6: Assembly Group with 6 Output Relays (Changeover / Form C)
- X3** – TI: Standard current measuring card
- X4** – TU: Card with 4 voltage transformer measuring inputs (0 ... 800 VAC, under UL: 0 ... 600 VAC)
- X5** – AnO4: Analog Outputs
- X102** – Universal Resistance-Temperature Detector (URTD) input, Fiber optics interface, Versatile Link
- X103** – Modbus TCP / IEC 60870-5-104 / DNP3.0 TCP/UDP, Fiber optics interface, LC Connector
- X104** – IRIG-B00X, incl. System Contact (Supervision Contact)

# MRMV4-2A0AOA

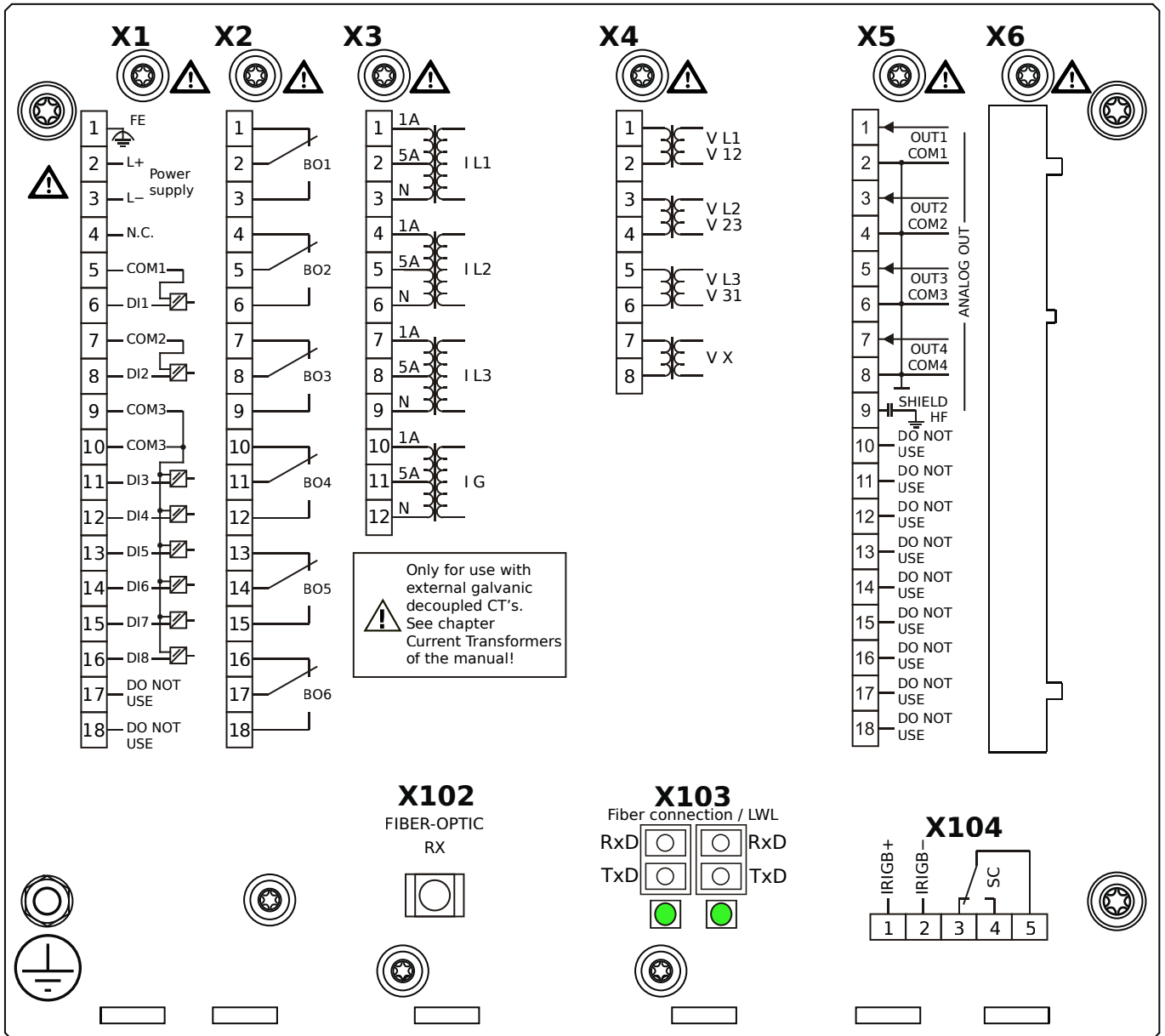

## Housing B2, small display, door mounting

- X1** – DI8-X1: Wide-range power supply unit, incl. 2 non-grouped digital inputs and 6 grouped digital inputs
- X2** – OR6: Assembly Group with 6 Output Relays (Changeover / Form C)
- X3** – TI: Standard current measuring card
- X4** – TU: Card with 4 voltage transformer measuring inputs (0 ... 800 VAC, under UL: 0 ... 600 VAC)
- X5** – AnO4: Analog Outputs
- X102** – Universal Resistance-Temperature Detector (URTD) input, Fiber optics interface, Versatile Link
- X103** – Modbus TCP / IEC 60870-5-104 / DNP3.0 TCP/UDP, Redundant Fiber optics interface, LC Connector
- X104** – IRIG-B00X, incl. System Contact (Supervision Contact)



# MRMV4-2A0AOB

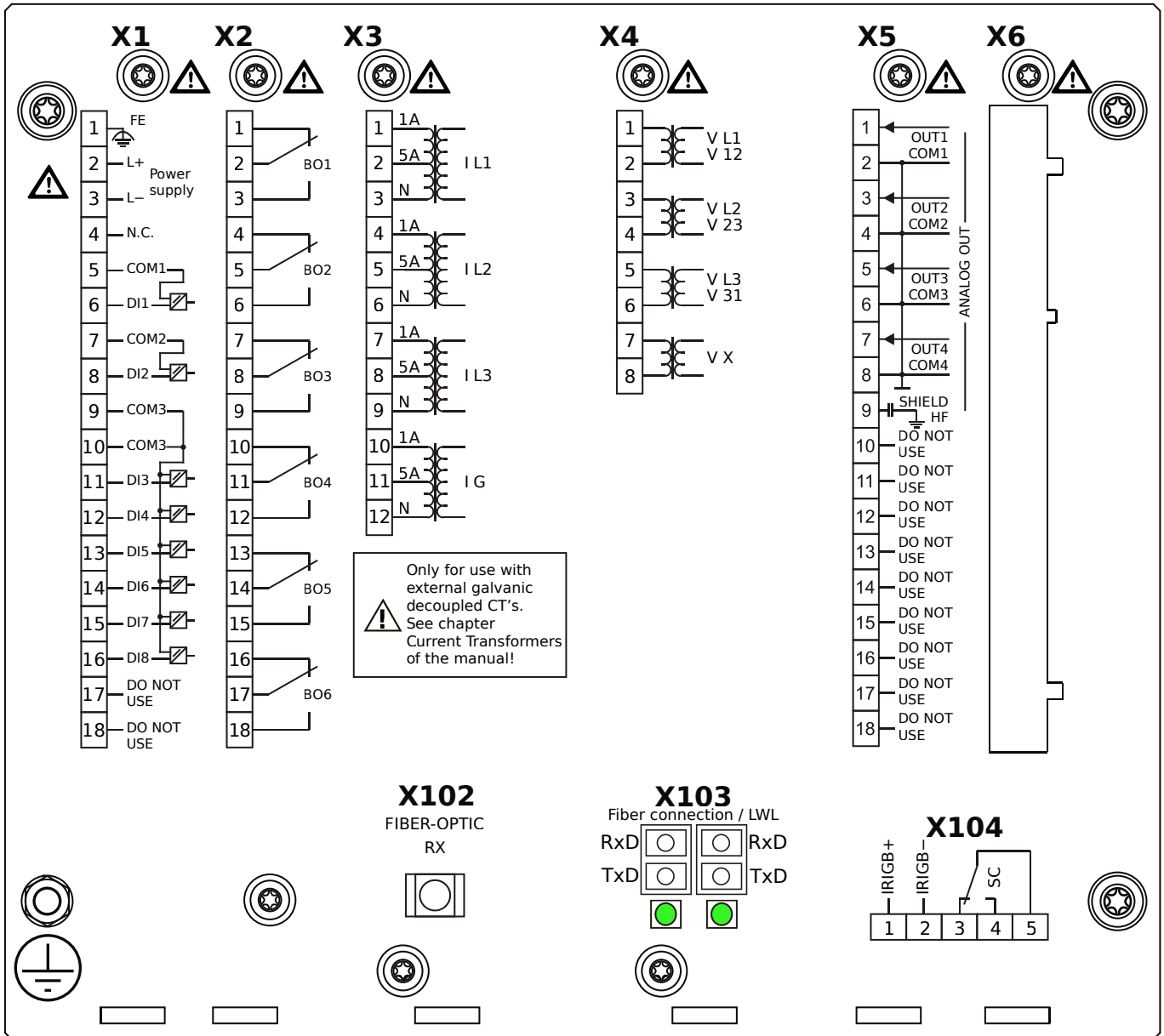

## Housing B2, small display, door mounting

- + Conformal Coating (for installations in harsh environment)

- X1** – DI8-X1: Wide-range power supply unit, incl. 2 non-grouped digital inputs and 6 grouped digital inputs
- X2** – OR6: Assembly Group with 6 Output Relays (Changeover / Form C)
- X3** – TI: Standard current measuring card
- X4** – TU: Card with 4 voltage transformer measuring inputs (0 ... 800 VAC, under UL: 0 ... 600 VAC)
- X5** – AnO4: Analog Outputs
- X102** – Universal Resistance-Temperature Detector (URTD) input, Fiber optics interface, Versatile Link
- X103** – Modbus TCP / IEC 60870-5-104 / DNP3.0 TCP/UDP, Redundant Fiber optics interface, LC Connector
- X104** – IRIG-B00X, incl. System Contact (Supervision Contact)

# MRMV4-2A0APA

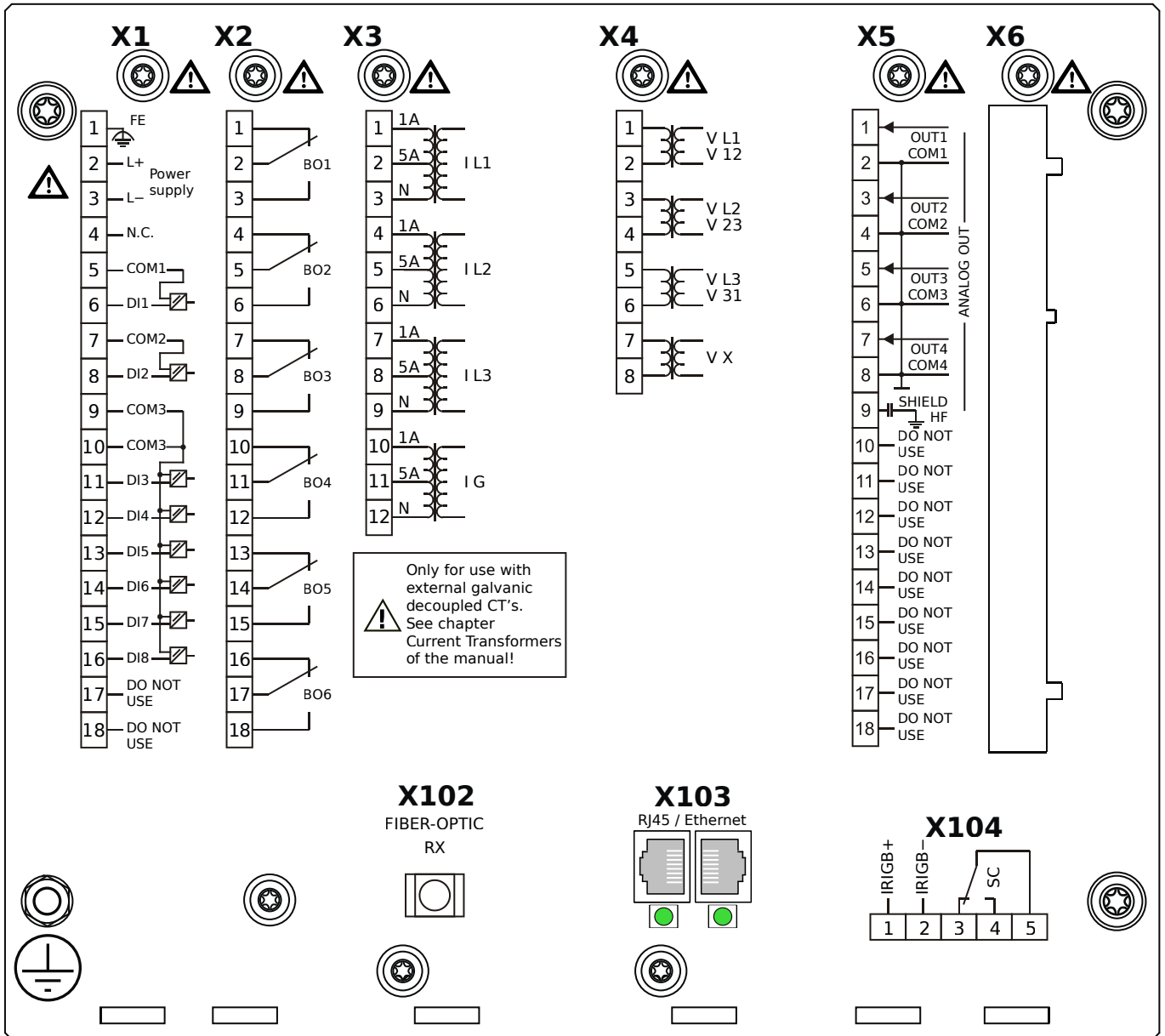

## Housing B2, small display, door mounting

- X1** – DI8-X1: Wide-range power supply unit, incl. 2 non-grouped digital inputs and 6 grouped digital inputs
- X2** – OR6: Assembly Group with 6 Output Relays (Changeover / Form C)
- X3** – TI: Standard current measuring card
- X4** – TU: Card with 4 voltage transformer measuring inputs (0 ... 800 VAC, under UL: 0 ... 600 VAC)
- X5** – AnO4: Analog Outputs
- X102** – Universal Resistance-Temperature Detector (URTD) input, Fiber optics interface, Versatile Link
- X103** – Modbus TCP / IEC 60870-5-104 / DNP3.0 TCP/UDP, Redundant Ethernet interface, 100 Mbit/s, RJ45 (BASE100-FX)
- X104** – IRIG-B00X, incl. System Contact (Supervision Contact)

# MRMV4-2A0APB

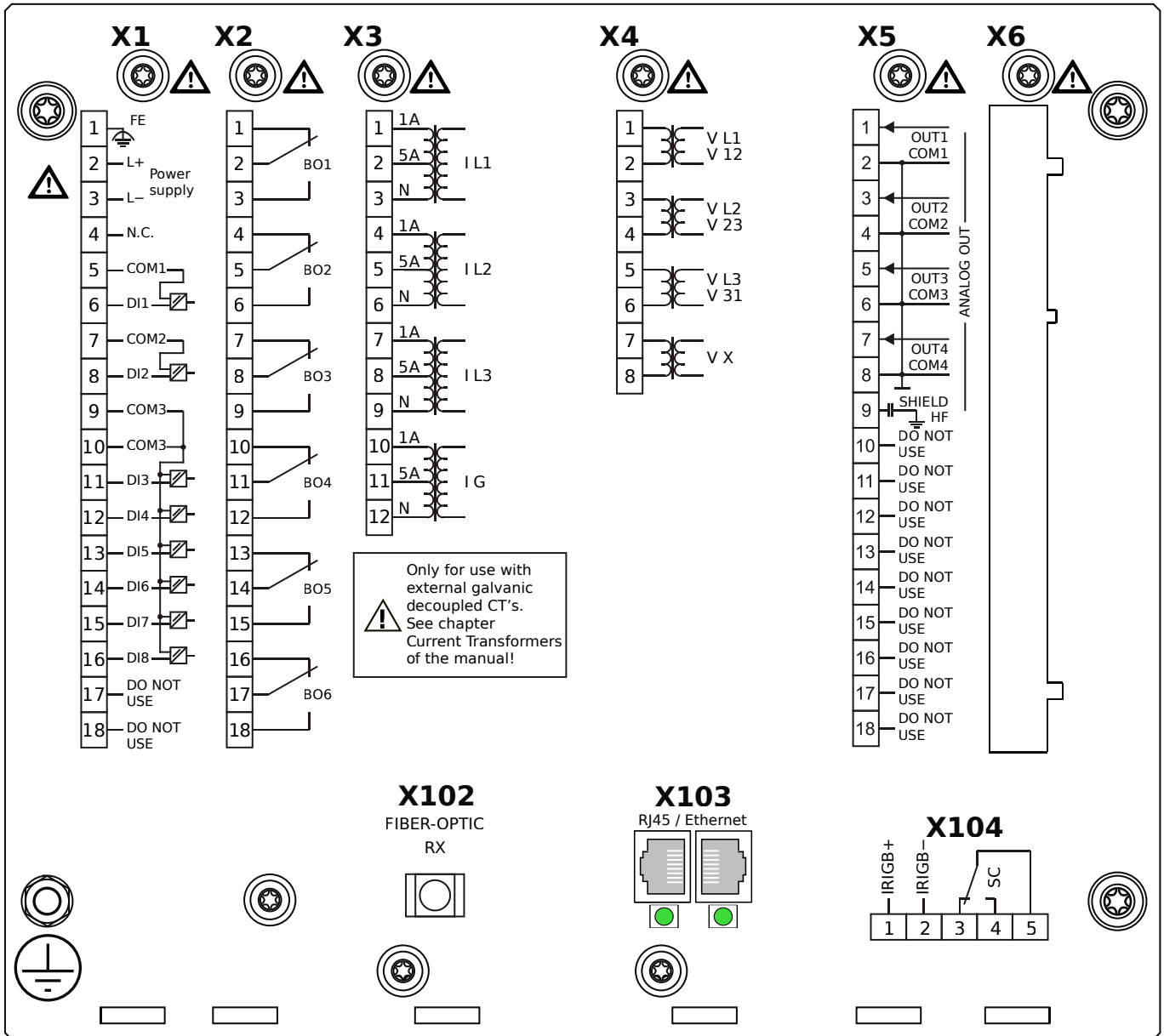

## Housing B2, small display, door mounting

- + Conformal Coating (for installations in harsh environment)

- X1** – DI8-X1: Wide-range power supply unit, incl. 2 non-grouped digital inputs and 6 grouped digital inputs
- X2** – OR6: Assembly Group with 6 Output Relays (Changeover / Form C)
- X3** – TI: Standard current measuring card
- X4** – TU: Card with 4 voltage transformer measuring inputs (0 ... 800 VAC, under UL: 0 ... 600 VAC)
- X5** – AnO4: Analog Outputs
- X102** – Universal Resistance-Temperature Detector (URTD) input, Fiber optics interface, Versatile Link
- X103** – Modbus TCP / IEC 60870-5-104 / DNP3.0 TCP/UDP, Redundant Ethernet interface, 100 Mbit/s, RJ45 (BASE100-FX)
- X104** – IRIG-B00X, incl. System Contact (Supervision Contact)

# MRMV4-2A0AQA

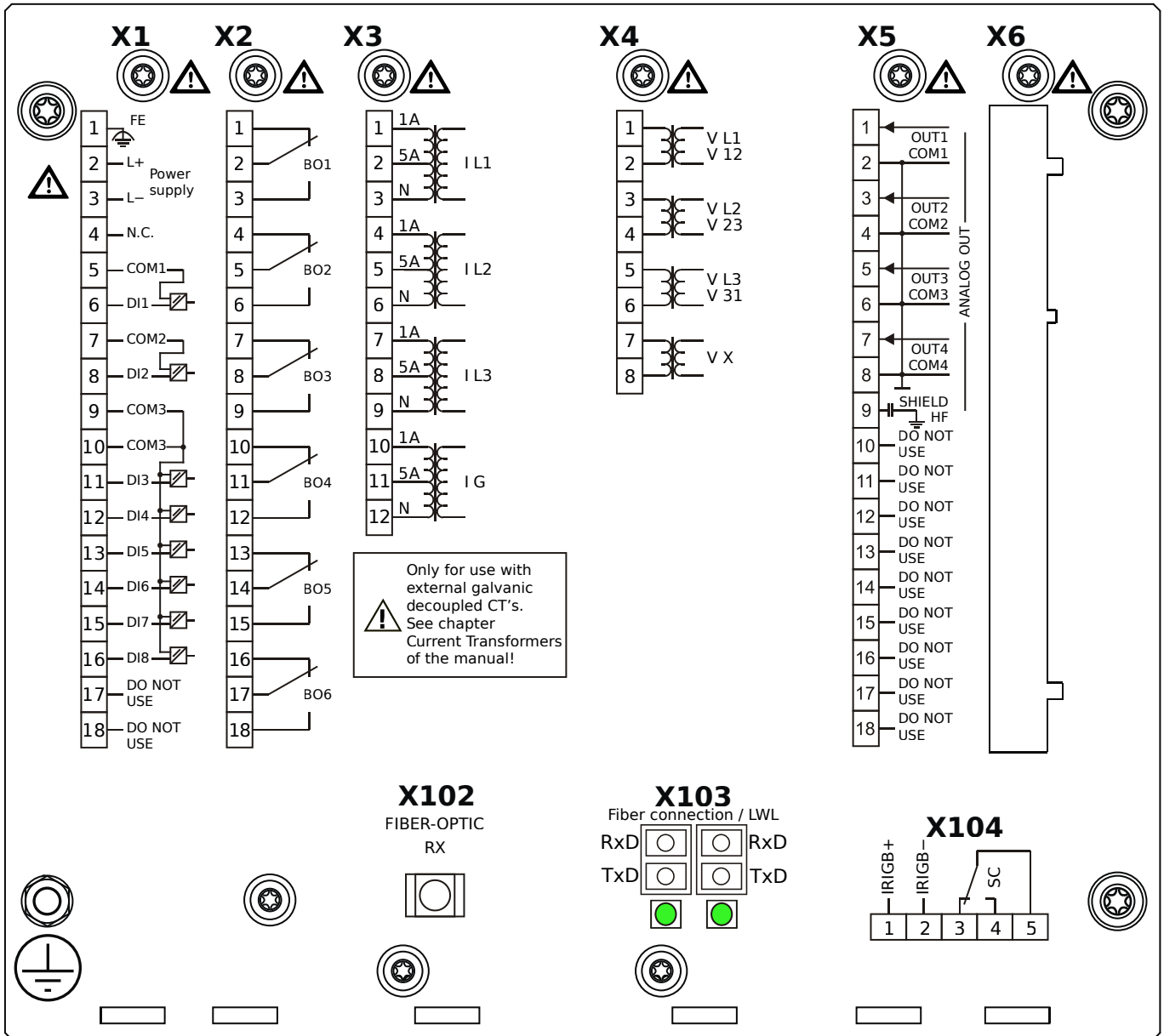

## Housing B2, small display, door mounting

- X1** – DI8-X1: Wide-range power supply unit, incl. 2 non-grouped digital inputs and 6 grouped digital inputs
- X2** – OR6: Assembly Group with 6 Output Relays (Changeover / Form C)
- X3** – TI: Standard current measuring card
- X4** – TU: Card with 4 voltage transformer measuring inputs (0 ... 800 VAC, under UL: 0 ... 600 VAC)
- X5** – AnO4: Analog Outputs
- X102** – Universal Resistance-Temperature Detector (URTD) input, Fiber optics interface, Versatile Link
- X103** – IEC 61850 / Modbus TCP / IEC 60870-5-104 / DNP3.0 TCP/UDP, Redundant Fiber optics interface, LC Connector
- X104** – IRIG-B00X, incl. System Contact (Supervision Contact)

# MRMV4-2A0AQB

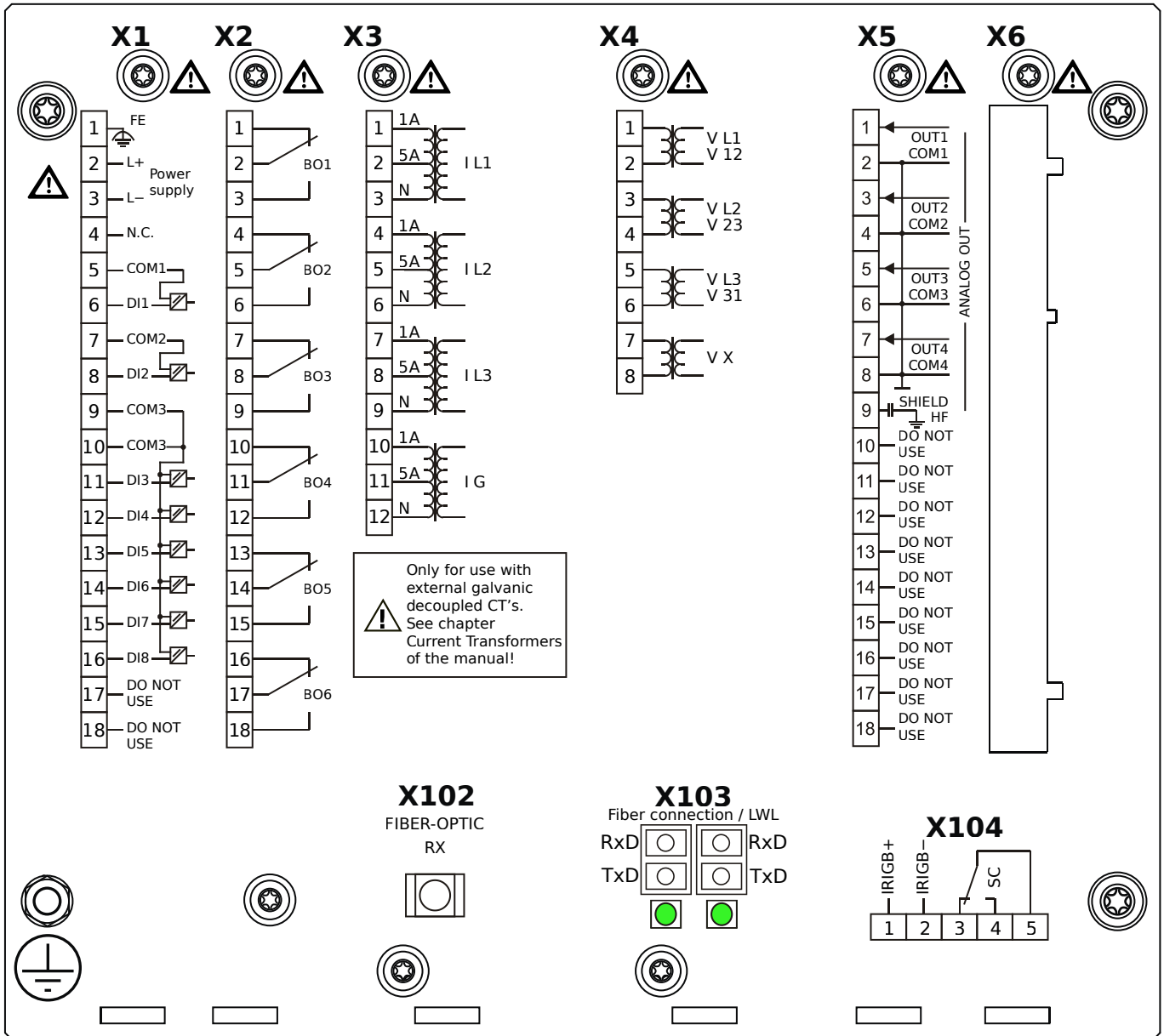

## Housing B2, small display, door mounting

- + Conformal Coating (for installations in harsh environment)

- X1** – DI8-X1: Wide-range power supply unit, incl. 2 non-grouped digital inputs and 6 grouped digital inputs
- X2** – OR6: Assembly Group with 6 Output Relays (Changeover / Form C)
- X3** – TI: Standard current measuring card
- X4** – TU: Card with 4 voltage transformer measuring inputs (0 ... 800 VAC, under UL: 0 ... 600 VAC)
- X5** – AnO4: Analog Outputs
- X102** – Universal Resistance-Temperature Detector (URTD) input, Fiber optics interface, Versatile Link
- X103** – IEC 61850 / Modbus TCP / IEC 60870-5-104 / DNP3.0 TCP/UDP, Redundant Fiber optics interface, LC Connector
- X104** – IRIG-B00X, incl. System Contact (Supervision Contact)

# MRMV4-2A0ARA

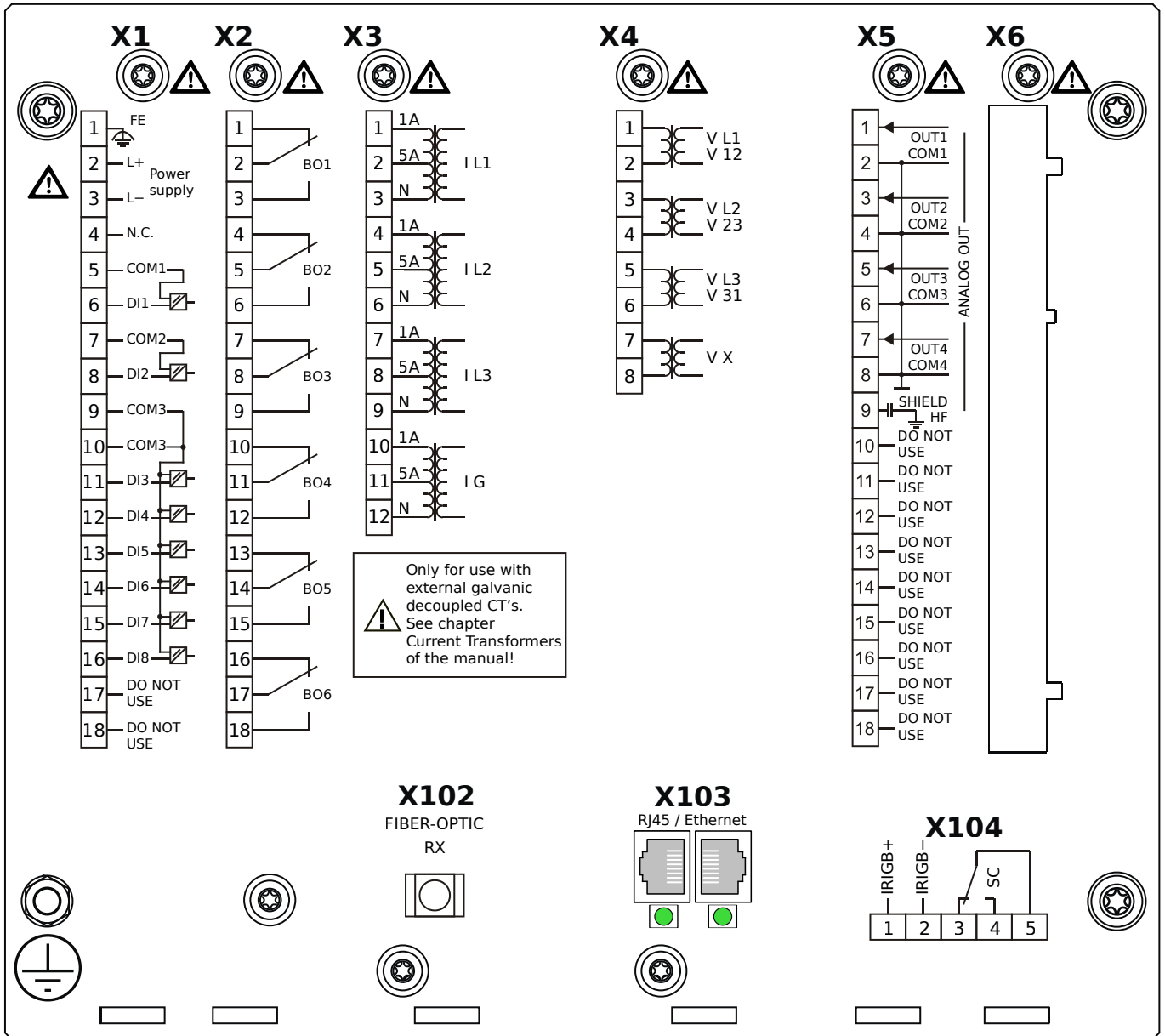

## Housing B2, small display, door mounting

- X1** – DI8-X1: Wide-range power supply unit, incl. 2 non-grouped digital inputs and 6 grouped digital inputs
- X2** – OR6: Assembly Group with 6 Output Relays (Changeover / Form C)
- X3** – TI: Standard current measuring card
- X4** – TU: Card with 4 voltage transformer measuring inputs (0 ... 800 VAC, under UL: 0 ... 600 VAC)
- X5** – AnO4: Analog Outputs
- X102** – Universal Resistance-Temperature Detector (URTD) input, Fiber optics interface, Versatile Link
- X103** – IEC 61850 / Modbus TCP / IEC 60870-5-104 / DNP3.0 TCP/UDP, Redundant Ethernet interface, 100 Mbit/s, RJ45 (BASE100-FX)
- X104** – IRIG-B00X, incl. System Contact (Supervision Contact)

# MRMV4-2A0ARB

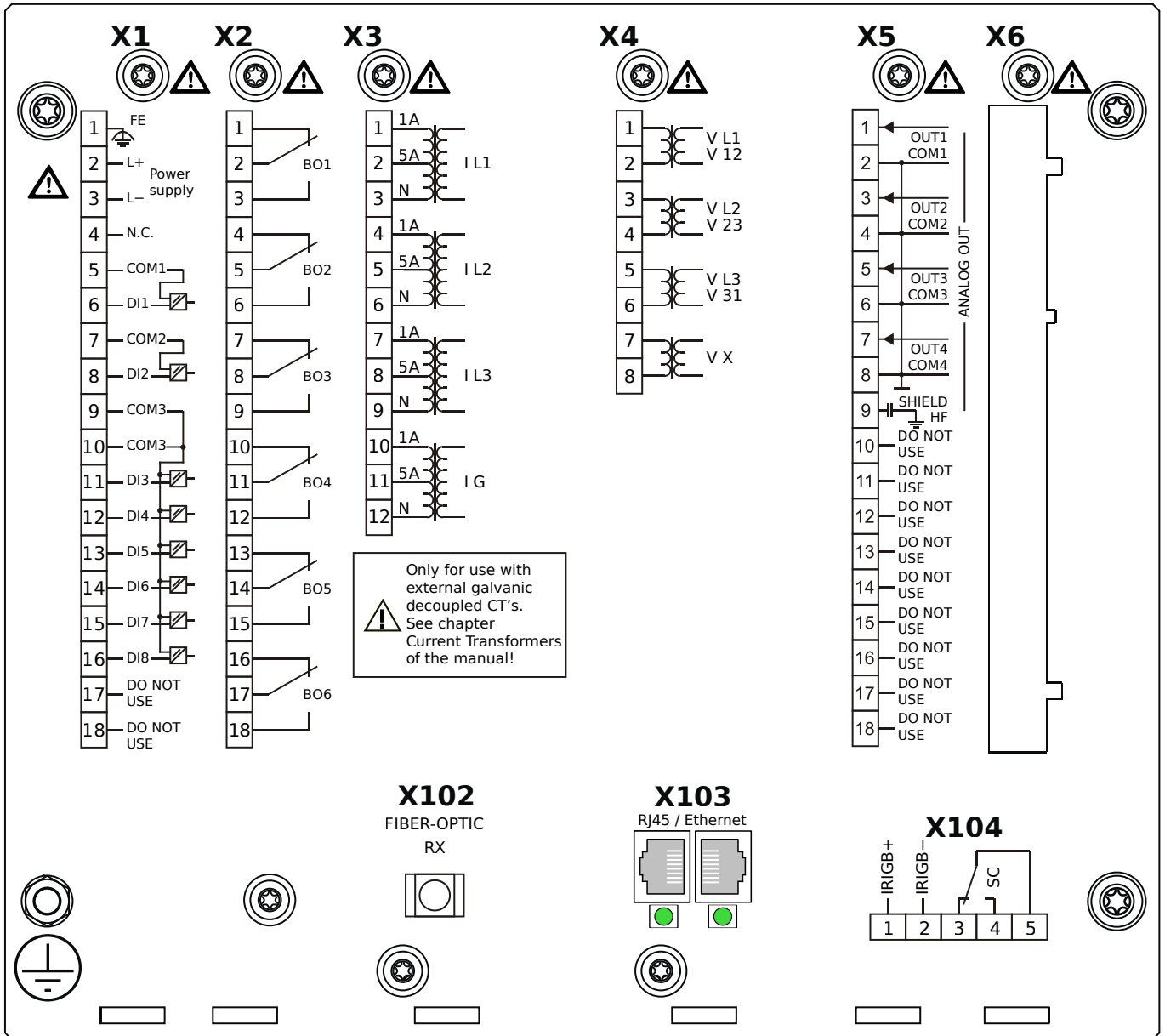

## Housing B2, small display, door mounting

- + Conformal Coating (for installations in harsh environment)

**X1** – DI8-X1: Wide-range power supply unit, incl. 2 non-grouped digital inputs and 6 grouped digital inputs

**X2** – OR6: Assembly Group with 6 Output Relays (Changeover / Form C)

**X3** – TI: Standard current measuring card

**X4** – TU: Card with 4 voltage transformer measuring inputs (0 ... 800 VAC, under UL: 0 ... 600 VAC)

**X5** – AnO4: Analog Outputs

**X102** – Universal Resistance-Temperature Detector (URTD) input, Fiber optics interface, Versatile Link

**X103** – IEC 61850 / Modbus TCP / IEC 60870-5-104 / DNP3.0 TCP/UDP, Redundant Ethernet interface, 100 Mbit/s, RJ45

(BASE100-FX)

**X104** – IRIG-B00X, incl. System Contact (Supervision Contact)

# MRMV4-2A0ATA

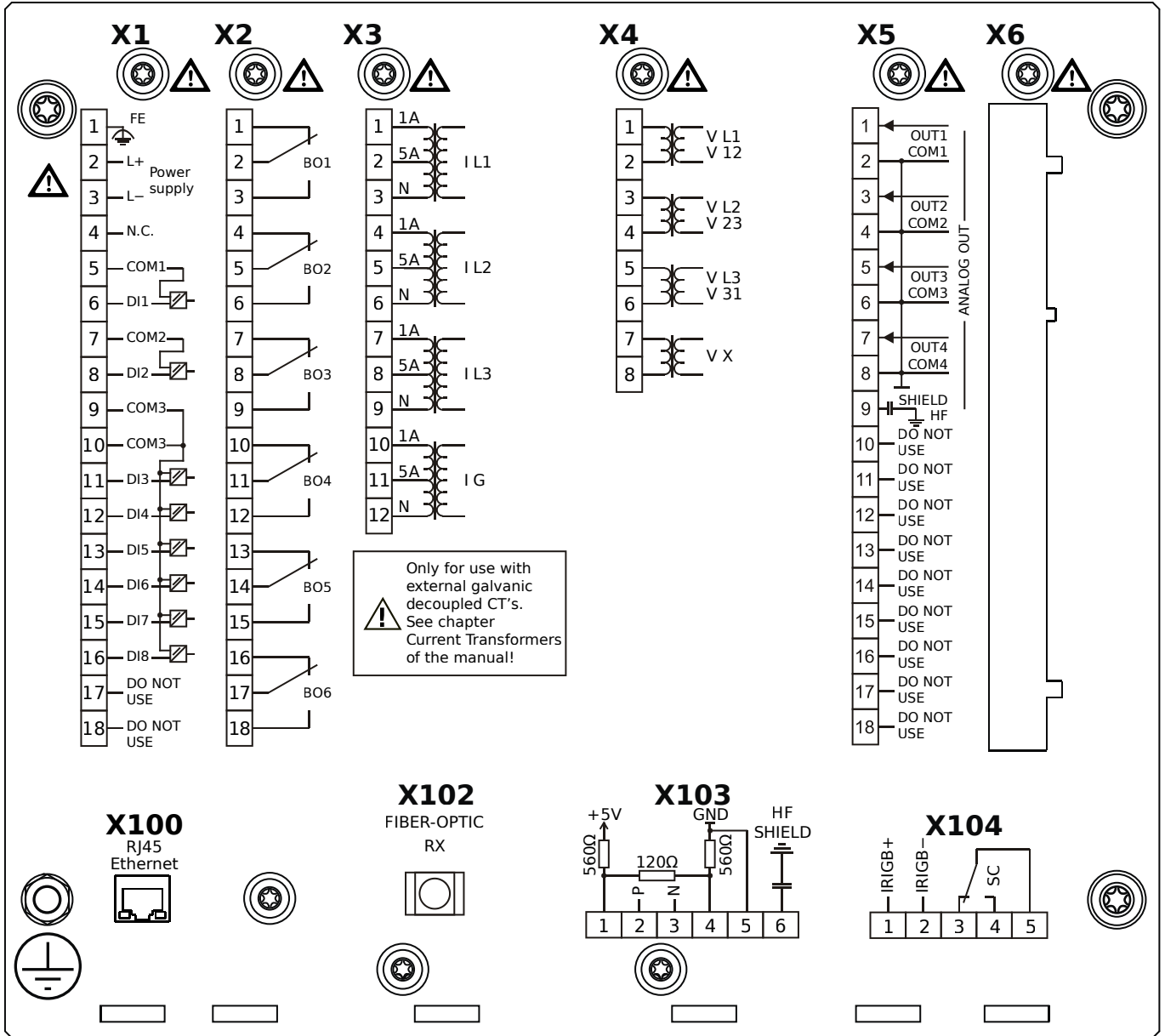

## Housing B2, small display, door mounting

- X1** – DI8-X1: Wide-range power supply unit, incl. 2 non-grouped digital inputs and 6 grouped digital inputs
- X2** – OR6: Assembly Group with 6 Output Relays (Changeover / Form C)
- X3** – TI: Standard current measuring card
- X4** – TU: Card with 4 voltage transformer measuring inputs (0 ... 800 VAC, under UL: 0 ... 600 VAC)
- X5** – AnO4: Analog Outputs
- X100** – IEC 61850 / Modbus TCP / IEC 60870-5-104 / DNP3.0 TCP/UDP, Ethernet interface, 100 Mbit/s, RJ45 (BASE100-FX)
- X102** – Universal Resistance-Temperature Detector (URTD) input, Fiber optics interface, Versatile Link
- X103** – IEC 60870-5-103 / Modbus RTU / DNP3.0 RTU, RS485, Terminals
- X104** – IRIG-B00X, incl. System Contact (Supervision Contact)



# MRMV4-2A0ATB

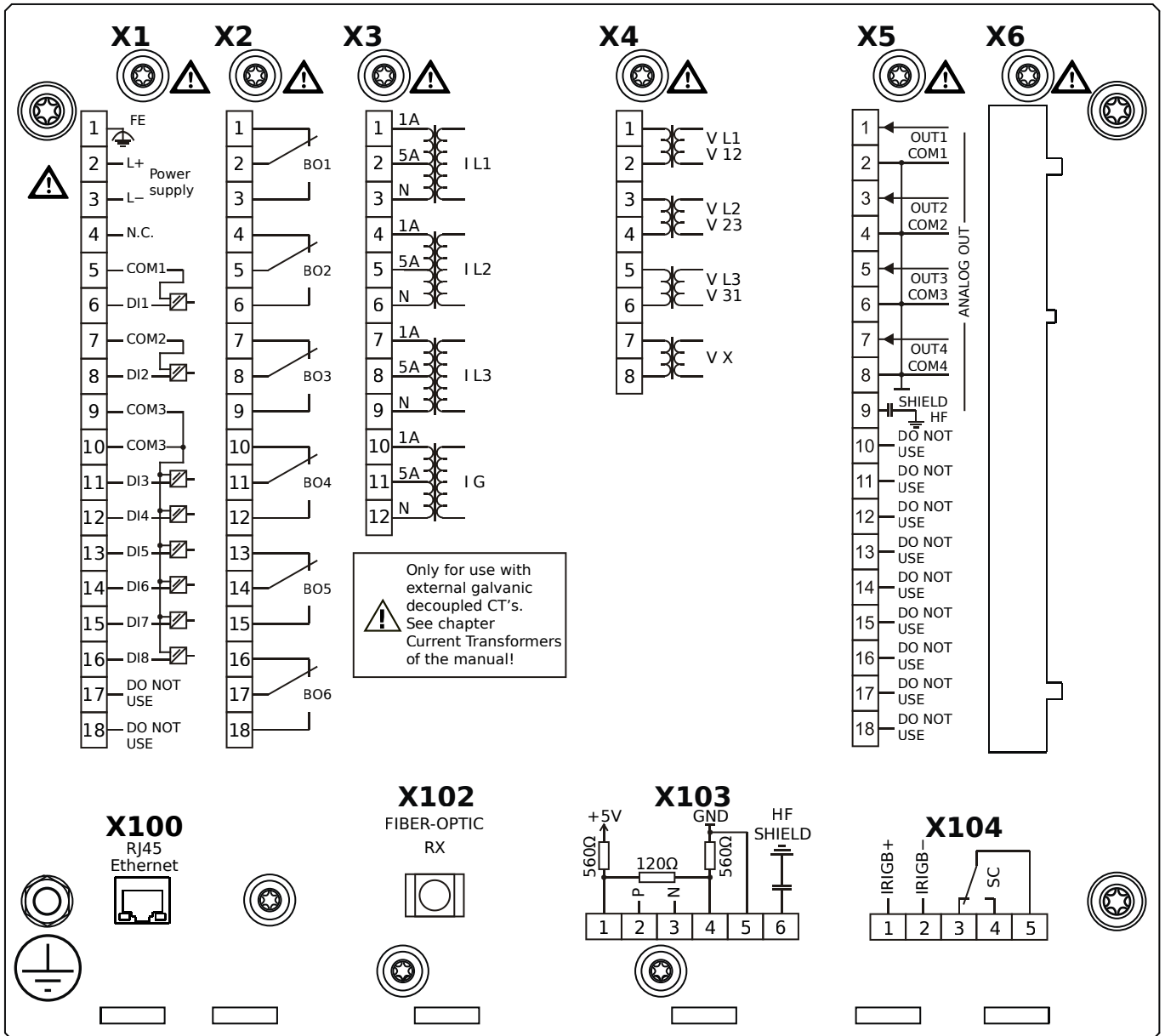

## Housing B2, small display, door mounting

+ Conformal Coating (for installations in harsh environment)

**X1** – DI8-X1: Wide-range power supply unit, incl. 2 non-grouped digital inputs and 6 grouped digital inputs

**X2** – OR6: Assembly Group with 6 Output Relays (Changeover / Form C)

**X3** – TI: Standard current measuring card

**X4** – TU: Card with 4 voltage transformer measuring inputs (0 ... 800 VAC, under UL: 0 ... 600 VAC)

**X5** – AnO4: Analog Outputs

**X100** – IEC 61850 / Modbus TCP / IEC 60870-5-104 / DNP3.0 TCP/UDP, Ethernet interface, 100 Mbit/s, RJ45 (BASE100-

FX)

**X102** – Universal Resistance-Temperature Detector (URTD) input, Fiber optics interface, Versatile Link

**X103** – IEC 60870-5-103 / Modbus RTU / DNP3.0 RTU, RS485, Terminals

**X104** – IRIG-B00X, incl. System Contact (Supervision Contact)

# MRMV4-2A0BAA

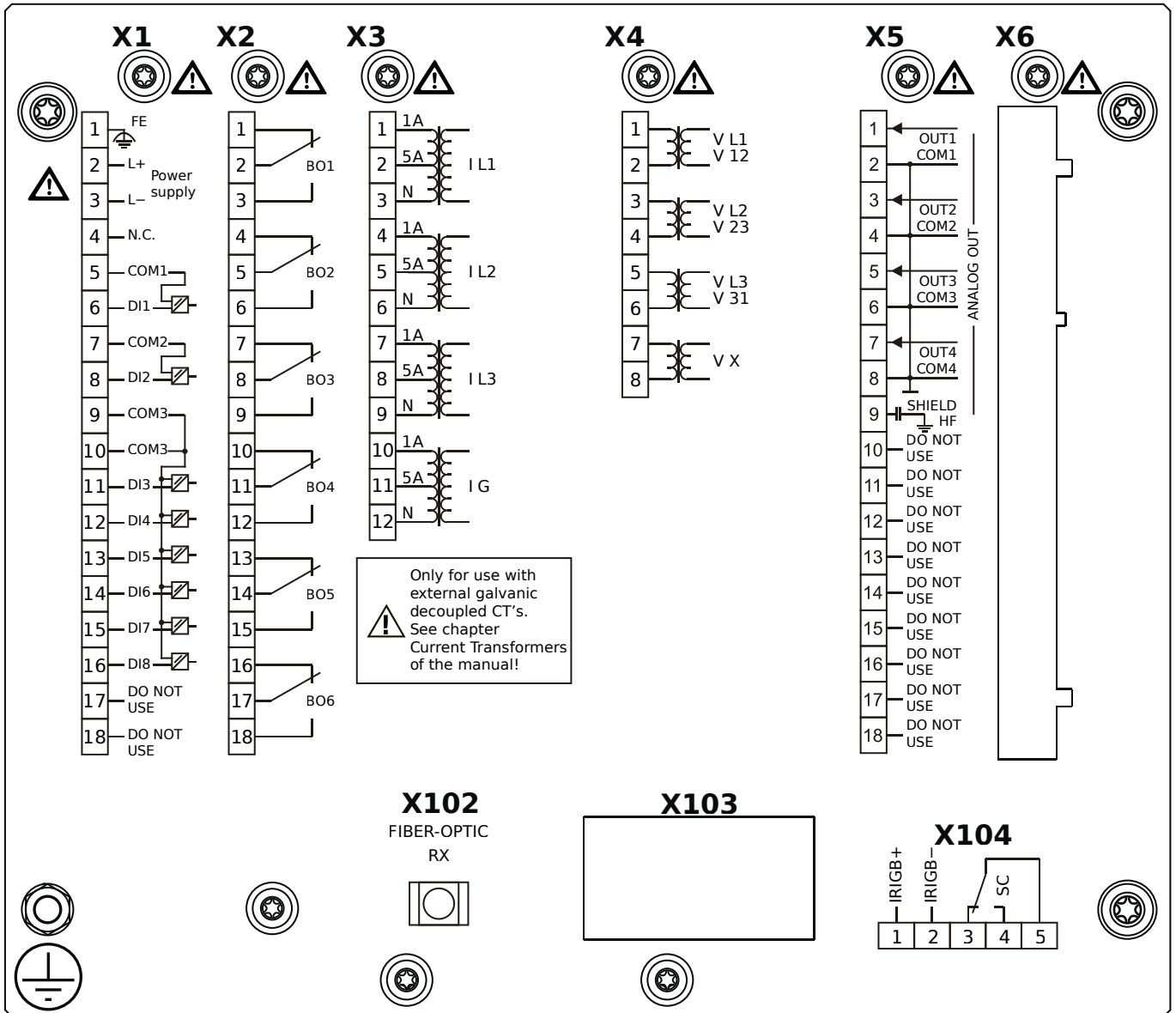

## Housing B2, small display, 19" rack mounting

- X1** – DI8-X1: Wide-range power supply unit, incl. 2 non-grouped digital inputs and 6 grouped digital inputs
- X2** – OR6: Assembly Group with 6 Output Relays (Changeover / Form C)
- X3** – TI: Standard current measuring card
- X4** – TU: Card with 4 voltage transformer measuring inputs (0 ... 800 VAC, under UL: 0 ... 600 VAC)
- X5** – AnO4: Analog Outputs
- X102** – Universal Resistance-Temperature Detector (URTD) input, Fiber optics interface, Versatile Link
- X104** – IRIG-B00X, incl. System Contact (Supervision Contact)

# MRMV4-2A0BAB

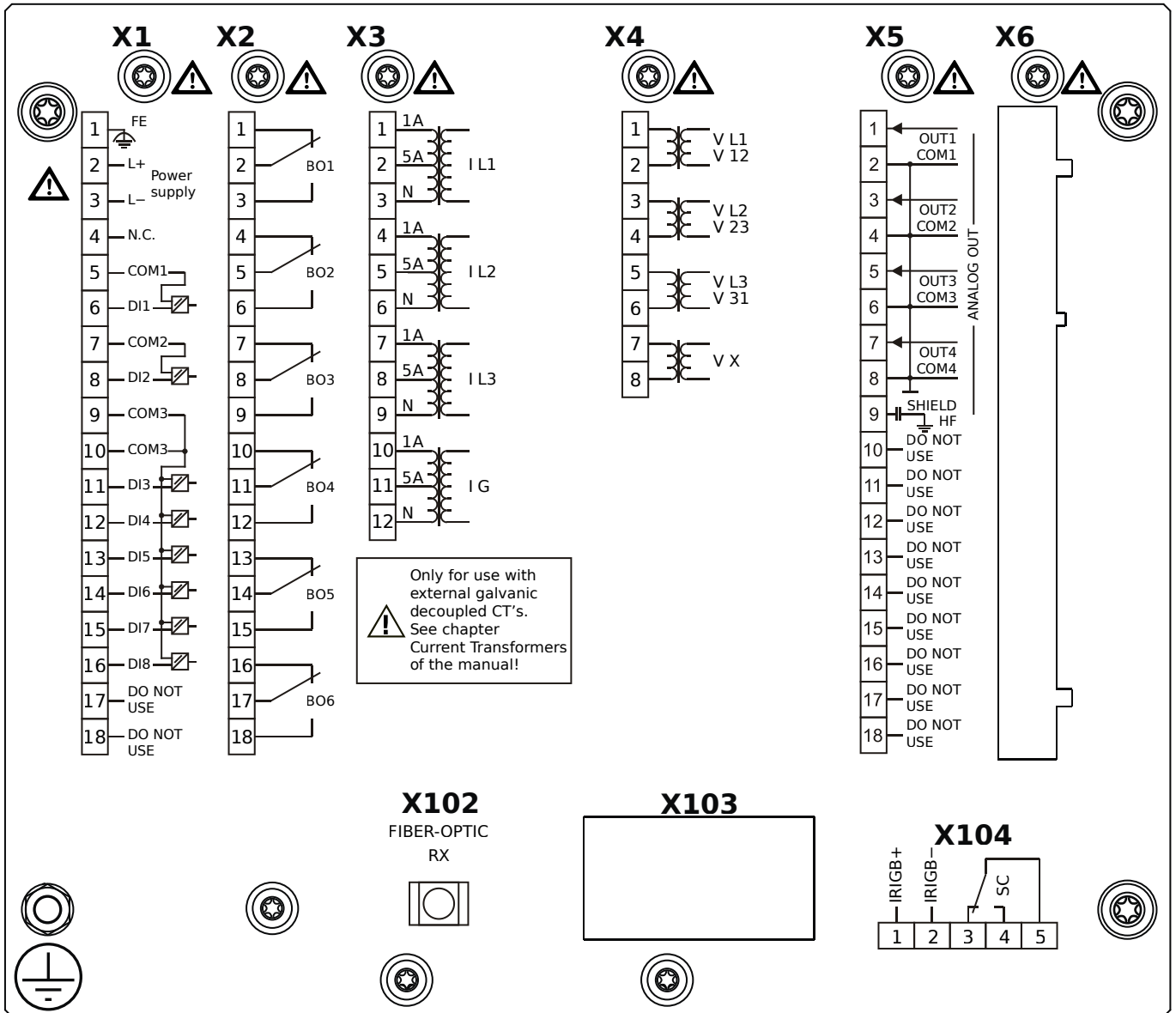

## Housing B2, small display, 19" rack mounting

+ Conformal Coating (for installations in harsh environment)

- X1** – DI8-X1: Wide-range power supply unit, incl. 2 non-grouped digital inputs and 6 grouped digital inputs
- X2** – OR6: Assembly Group with 6 Output Relays (Changeover / Form C)
- X3** – TI: Standard current measuring card
- X4** – TU: Card with 4 voltage transformer measuring inputs (0 ... 800 VAC, under UL: 0 ... 600 VAC)
- X5** – AnO4: Analog Outputs
- X102** – Universal Resistance-Temperature Detector (URTD) input, Fiber optics interface, Versatile Link
- X104** – IRIG-B00X, incl. System Contact (Supervision Contact)

# MRMV4-2A0BBA

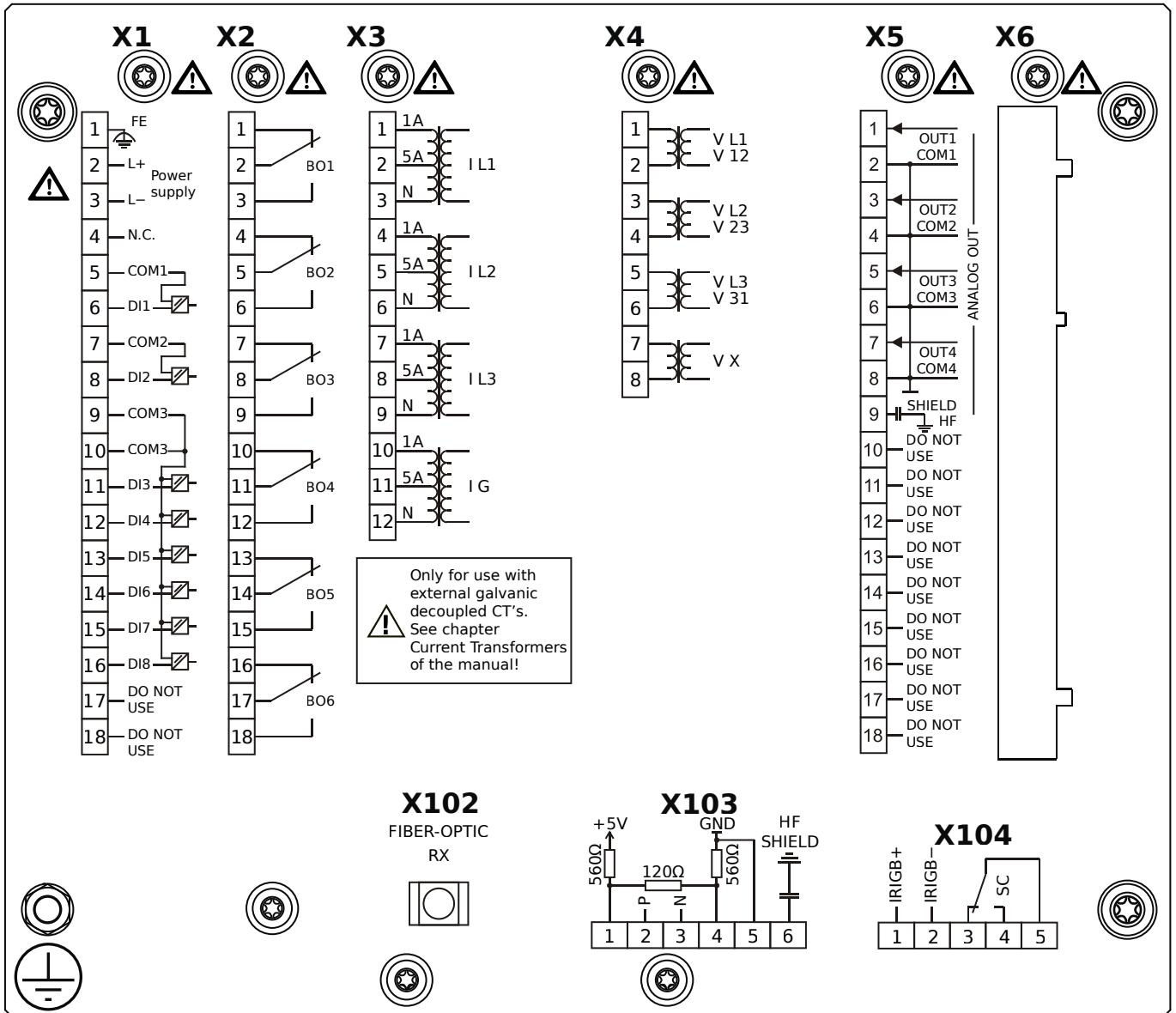

## Housing B2, small display, 19" rack mounting

- X1** – DI8-X1: Wide-range power supply unit, incl. 2 non-grouped digital inputs and 6 grouped digital inputs
- X2** – OR6: Assembly Group with 6 Output Relays (Changeover / Form C)
- X3** – TI: Standard current measuring card
- X4** – TU: Card with 4 voltage transformer measuring inputs (0 ... 800 VAC, under UL: 0 ... 600 VAC)
- X5** – AnO4: Analog Outputs
- X102** – Universal Resistance-Temperature Detector (URTD) input, Fiber optics interface, Versatile Link
- X103** – Modbus RTU / IEC 60870-5-103 / DNP3.0 RTU, RS485, Terminals
- X104** – IRIG-B00X, incl. System Contact (Supervision Contact)

# MRMV4-2A0BBB

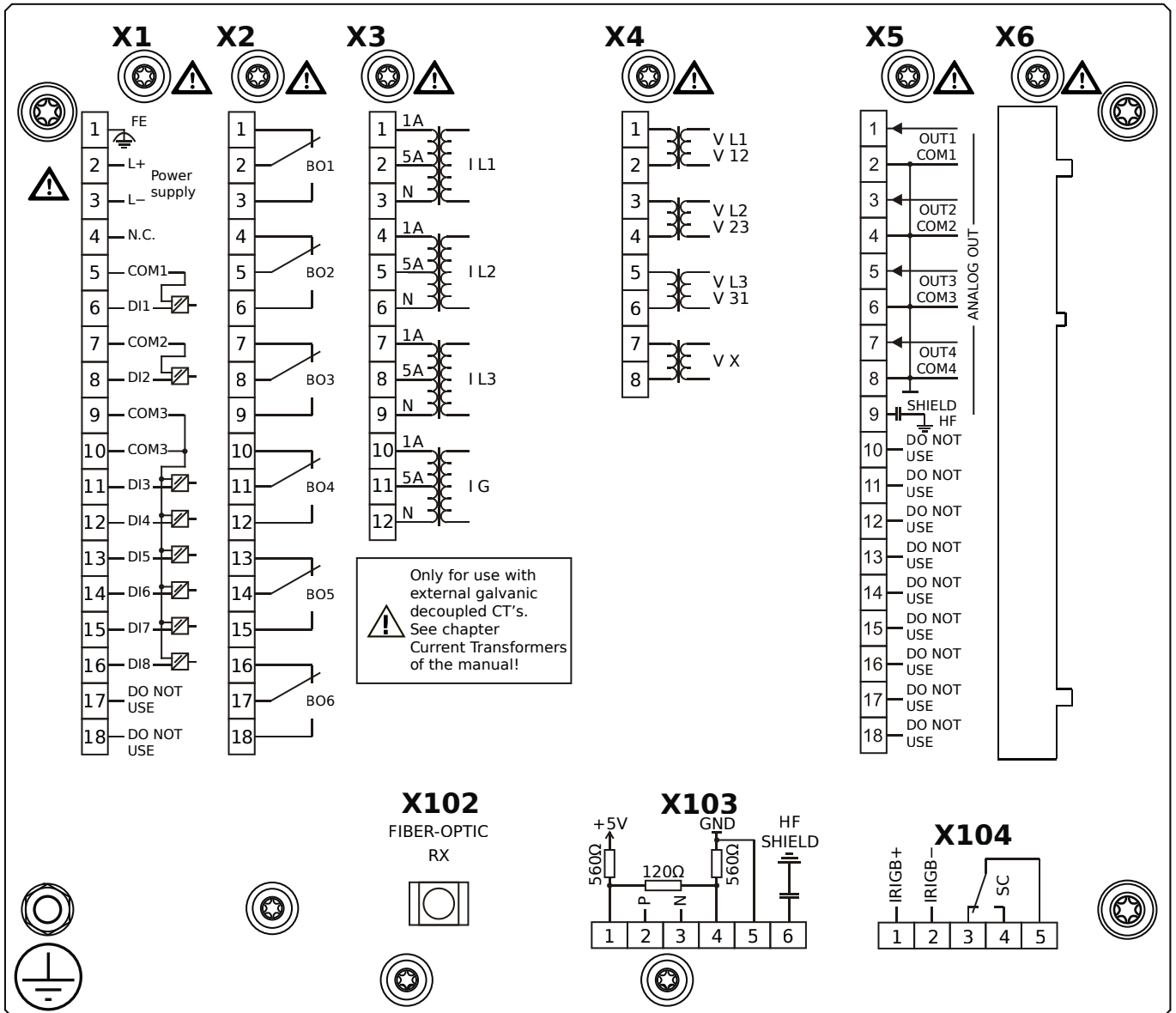

## Housing B2, small display, 19" rack mounting

+ Conformal Coating (for installations in harsh environment)

- X1** – DI8-X1: Wide-range power supply unit, incl. 2 non-grouped digital inputs and 6 grouped digital inputs
- X2** – OR6: Assembly Group with 6 Output Relays (Changeover / Form C)
- X3** – TI: Standard current measuring card
- X4** – TU: Card with 4 voltage transformer measuring inputs (0 ... 800 VAC, under UL: 0 ... 600 VAC)
- X5** – AnO4: Analog Outputs
- X102** – Universal Resistance-Temperature Detector (URTD) input, Fiber optics interface, Versatile Link
- X103** – Modbus RTU / IEC 60870-5-103 / DNP3.0 RTU, RS485, Terminals
- X104** – IRIG-B00X, incl. System Contact (Supervision Contact)

# MRMV4-2A0BCA

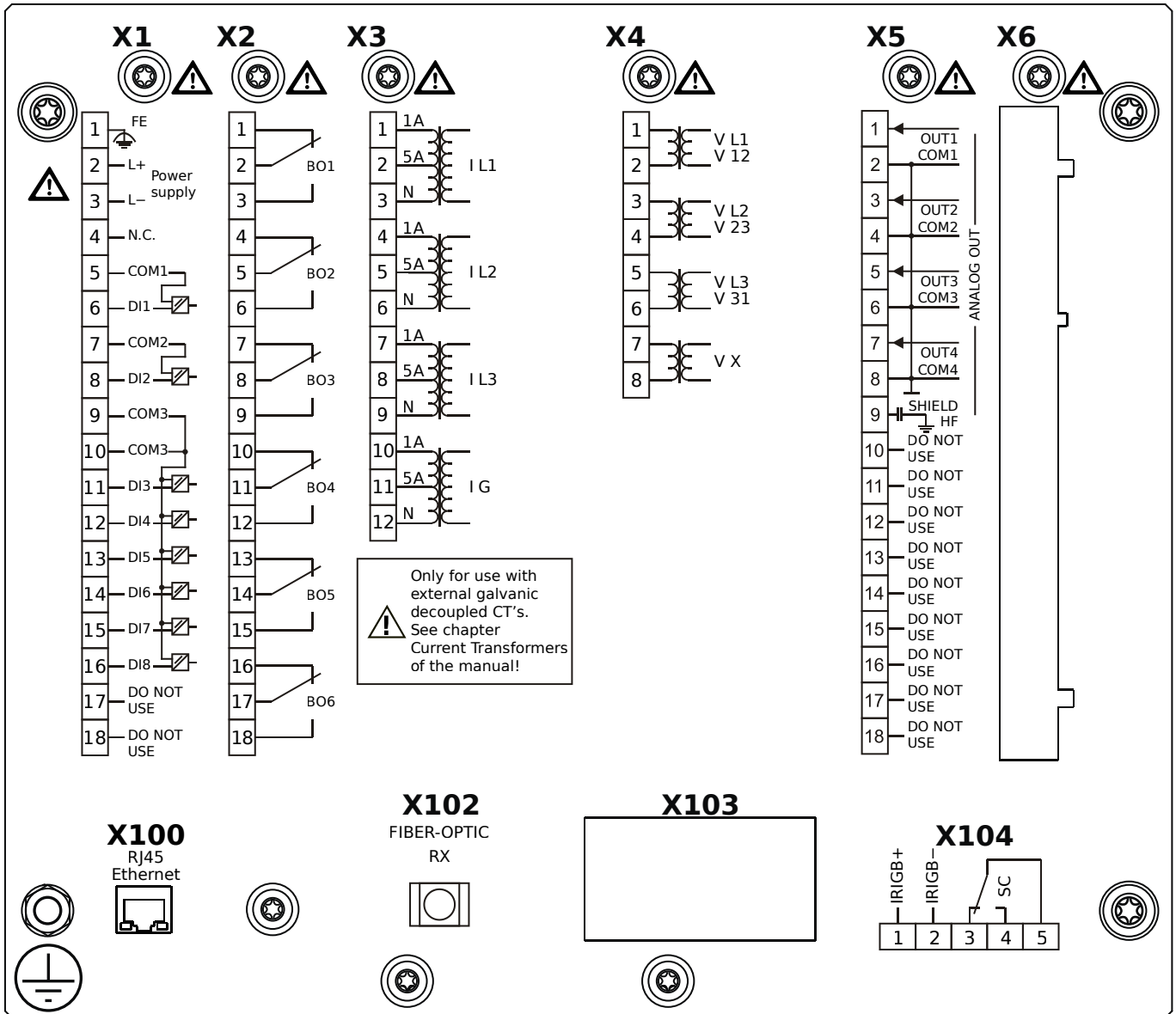

## Housing B2, small display, 19" rack mounting

- X1** – DI8-X1: Wide-range power supply unit, incl. 2 non-grouped digital inputs and 6 grouped digital inputs
- X2** – OR6: Assembly Group with 6 Output Relays (Changeover / Form C)
- X3** – TI: Standard current measuring card
- X4** – TU: Card with 4 voltage transformer measuring inputs (0 ... 800 VAC, under UL: 0 ... 600 VAC)
- X5** – AnO4: Analog Outputs
- X100** – Modbus TCP / IEC 60870-5-104 / DNP3.0 TCP/UDP, Ethernet interface, 100 Mbit/s, RJ45 (BASE100-FX)
- X102** – Universal Resistance-Temperature Detector (URTD) input, Fiber optics interface, Versatile Link
- X104** – IRIG-B00X, incl. System Contact (Supervision Contact)

# MRMV4-2A0BCB

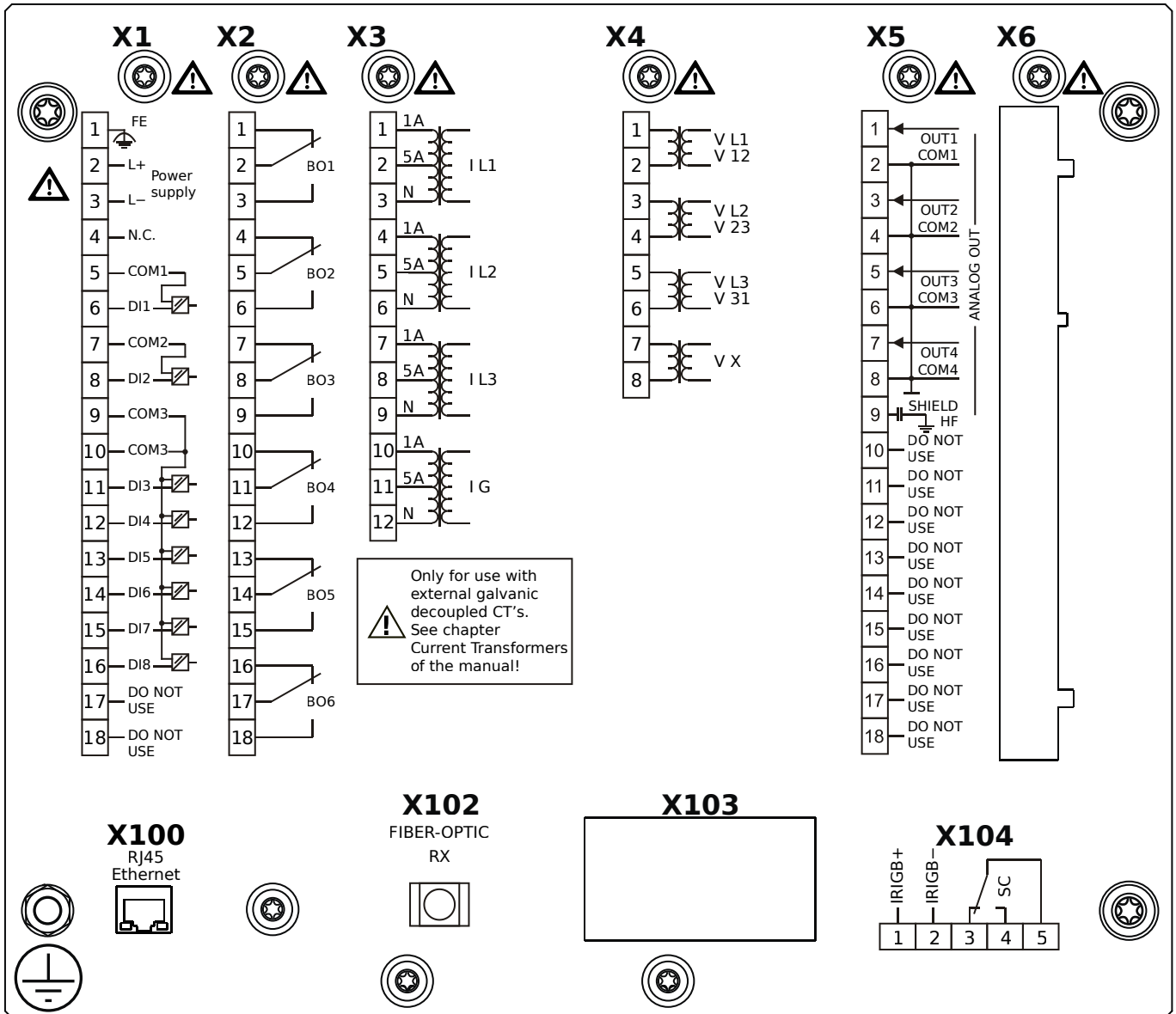

## Housing B2, small display, 19" rack mounting

- + Conformal Coating (for installations in harsh environment)

- X1** – DI8-X1: Wide-range power supply unit, incl. 2 non-grouped digital inputs and 6 grouped digital inputs
- X2** – OR6: Assembly Group with 6 Output Relays (Changeover / Form C)
- X3** – TI: Standard current measuring card
- X4** – TU: Card with 4 voltage transformer measuring inputs (0 ... 800 VAC, under UL: 0 ... 600 VAC)
- X5** – AnO4: Analog Outputs
- X100** – Modbus TCP / IEC 60870-5-104 / DNP3.0 TCP/UDP, Ethernet interface, 100 Mbit/s, RJ45 (BASE100-FX)
- X102** – Universal Resistance-Temperature Detector (URTD) input, Fiber optics interface, Versatile Link
- X104** – IRIG-B00X, incl. System Contact (Supervision Contact)

# MRMV4-2A0BDA

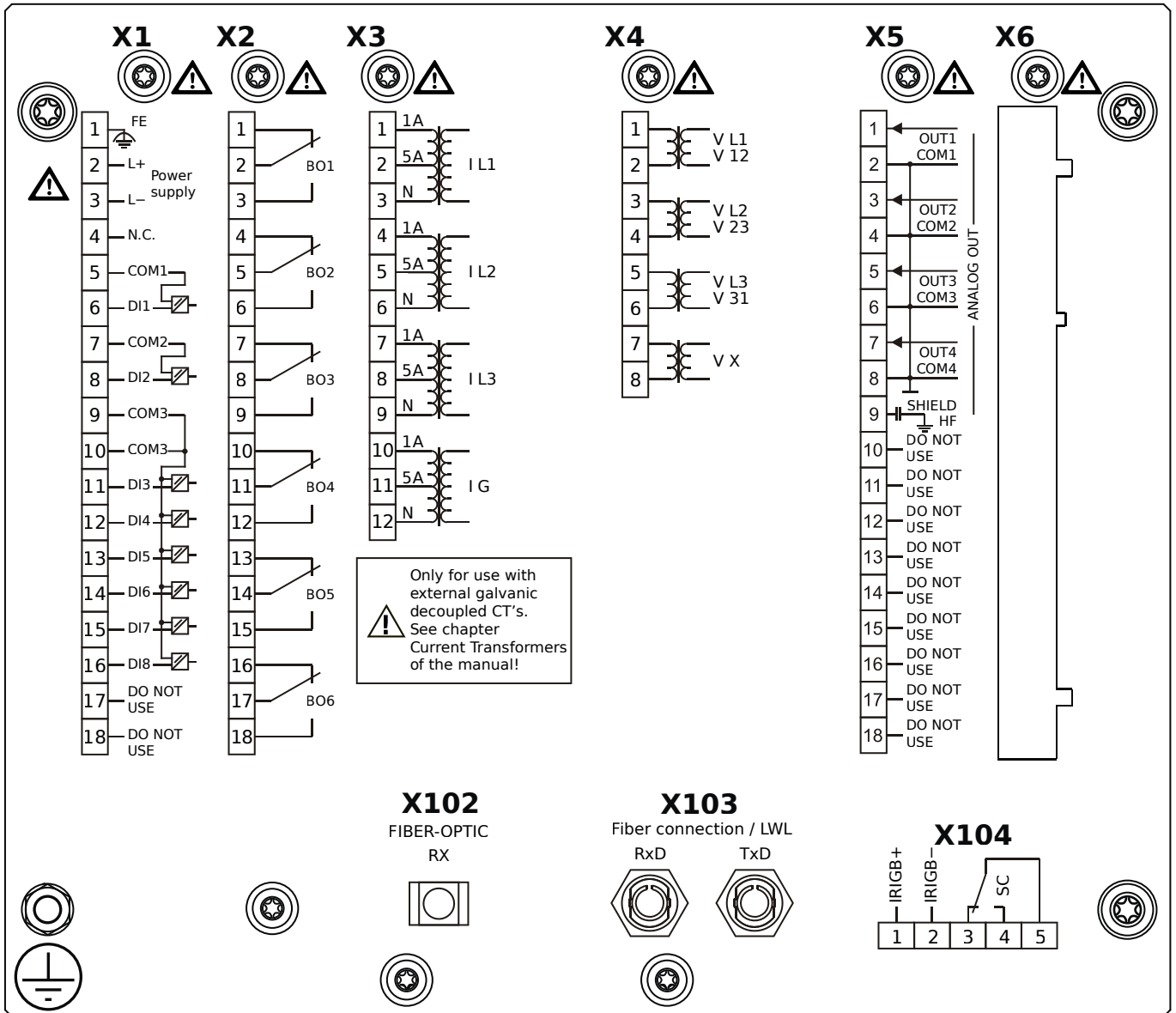

## Housing B2, small display, 19" rack mounting

- X1** – DI8-X1: Wide-range power supply unit, incl. 2 non-grouped digital inputs and 6 grouped digital inputs
- X2** – OR6: Assembly Group with 6 Output Relays (Changeover / Form C)
- X3** – TI: Standard current measuring card
- X4** – TU: Card with 4 voltage transformer measuring inputs (0 ... 800 VAC, under UL: 0 ... 600 VAC)
- X5** – AnO4: Analog Outputs
- X102** – Universal Resistance-Temperature Detector (URTD) input, Fiber optics interface, Versatile Link
- X103** – Profibus-DP, Fiber optics interface, ST Connector
- X104** – IRIG-B00X, incl. System Contact (Supervision Contact)



# MRMV4-2A0BDB

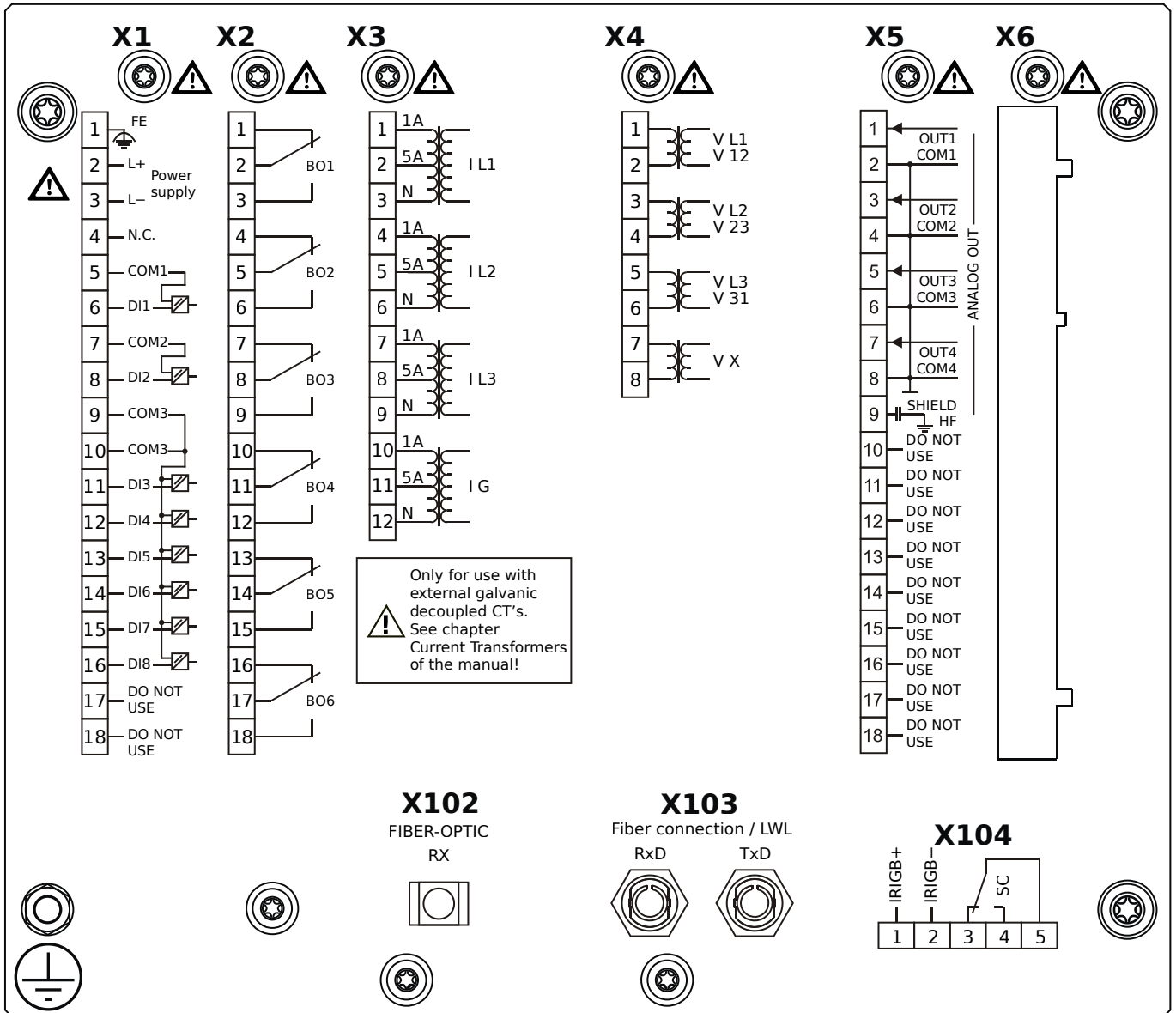

## Housing B2, small display, 19" rack mounting

+ Conformal Coating (for installations in harsh environment)

- X1** – DI8-X1: Wide-range power supply unit, incl. 2 non-grouped digital inputs and 6 grouped digital inputs
- X2** – OR6: Assembly Group with 6 Output Relays (Changeover / Form C)
- X3** – TI: Standard current measuring card
- X4** – TU: Card with 4 voltage transformer measuring inputs (0 ... 800 VAC, under UL: 0 ... 600 VAC)
- X5** – AnO4: Analog Outputs
- X102** – Universal Resistance-Temperature Detector (URTD) input, Fiber optics interface, Versatile Link
- X103** – Profibus-DP, Fiber optics interface, ST Connector
- X104** – IRIG-B00X, incl. System Contact (Supervision Contact)

# MRMV4-2A0BEA

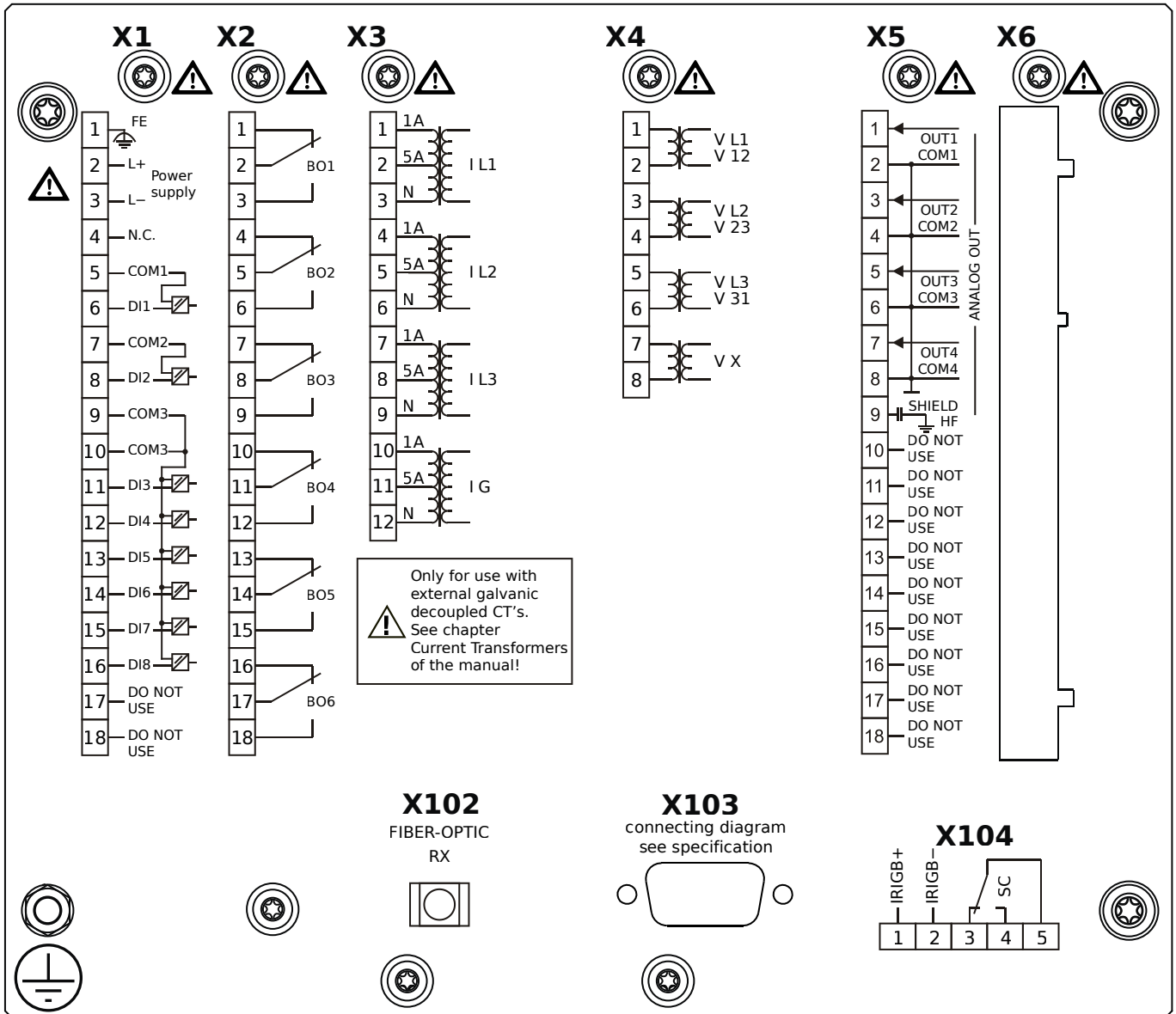

## Housing B2, small display, 19" rack mounting

- X1** – DI8-X1: Wide-range power supply unit, incl. 2 non-grouped digital inputs and 6 grouped digital inputs
- X2** – OR6: Assembly Group with 6 Output Relays (Changeover / Form C)
- X3** – TI: Standard current measuring card
- X4** – TU: Card with 4 voltage transformer measuring inputs (0 ... 800 VAC, under UL: 0 ... 600 VAC)
- X5** – AnO4: Analog Outputs
- X102** – Universal Resistance-Temperature Detector (URTD) input, Fiber optics interface, Versatile Link
- X103** – Profibus-DP, RS485, D-SUB
- X104** – IRIG-B00X, incl. System Contact (Supervision Contact)

# MRMV4-2A0BEB

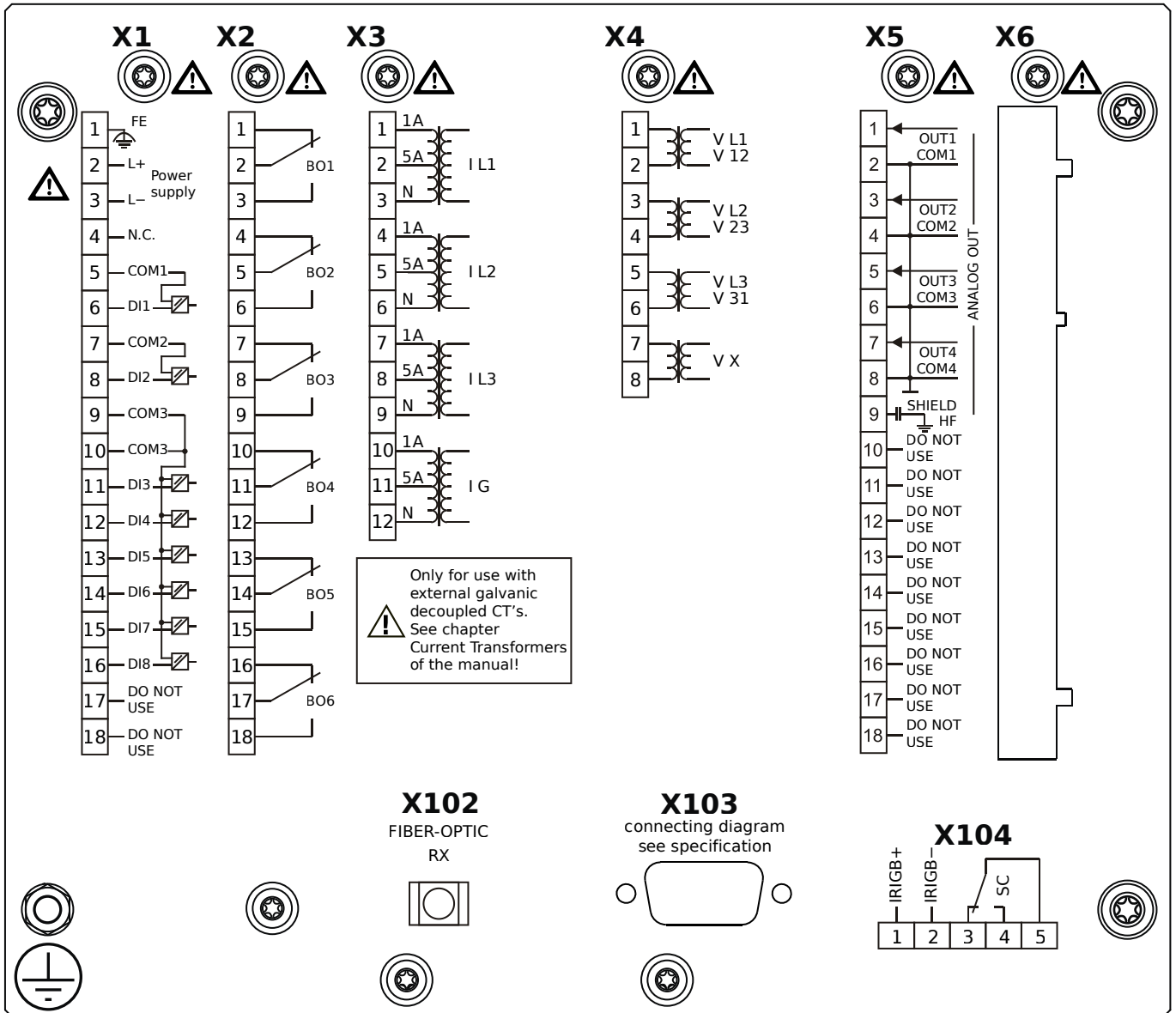

## Housing B2, small display, 19" rack mounting

+ Conformal Coating (for installations in harsh environment)

- X1** – DI8-X1: Wide-range power supply unit, incl. 2 non-grouped digital inputs and 6 grouped digital inputs
- X2** – OR6: Assembly Group with 6 Output Relays (Changeover / Form C)
- X3** – TI: Standard current measuring card
- X4** – TU: Card with 4 voltage transformer measuring inputs (0 ... 800 VAC, under UL: 0 ... 600 VAC)
- X5** – AnO4: Analog Outputs
- X102** – Universal Resistance-Temperature Detector (URTD) input, Fiber optics interface, Versatile Link
- X103** – Profibus-DP, RS485, D-SUB
- X104** – IRIG-B00X, incl. System Contact (Supervision Contact)

# MRMV4-2A0BFA

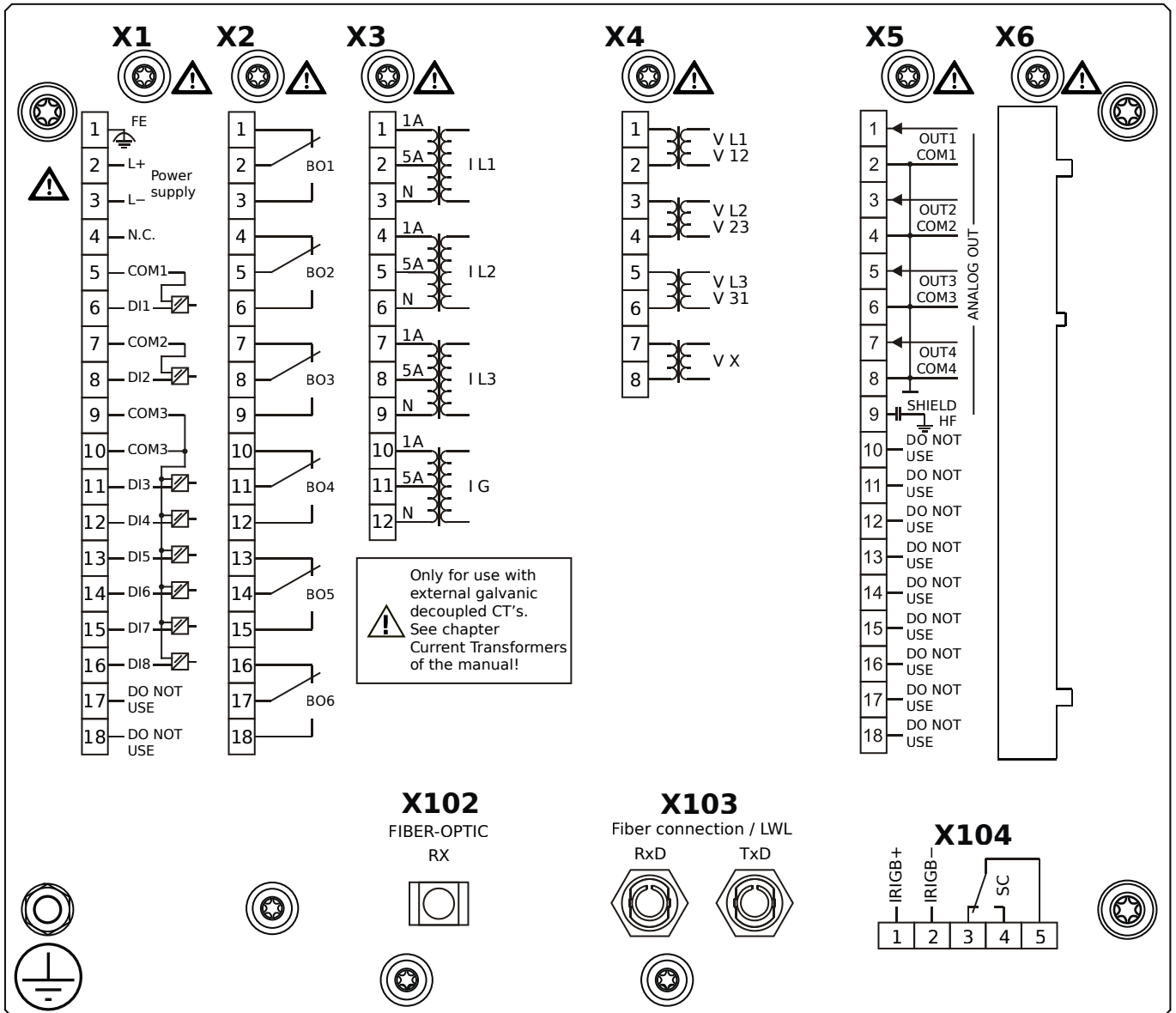

## Housing B2, small display, 19" rack mounting

- X1** – DI8-X1: Wide-range power supply unit, incl. 2 non-grouped digital inputs and 6 grouped digital inputs
- X2** – OR6: Assembly Group with 6 Output Relays (Changeover / Form C)
- X3** – TI: Standard current measuring card
- X4** – TU: Card with 4 voltage transformer measuring inputs (0 ... 800 VAC, under UL: 0 ... 600 VAC)
- X5** – AnO4: Analog Outputs
- X102** – Universal Resistance-Temperature Detector (URTD) input, Fiber optics interface, Versatile Link
- X103** – Modbus RTU / IEC 60870-5-103 / DNP3.0 RTU, Fiber optics interface, ST Connector
- X104** – IRIG-B00X, incl. System Contact (Supervision Contact)

# MRMV4-2A0BFB

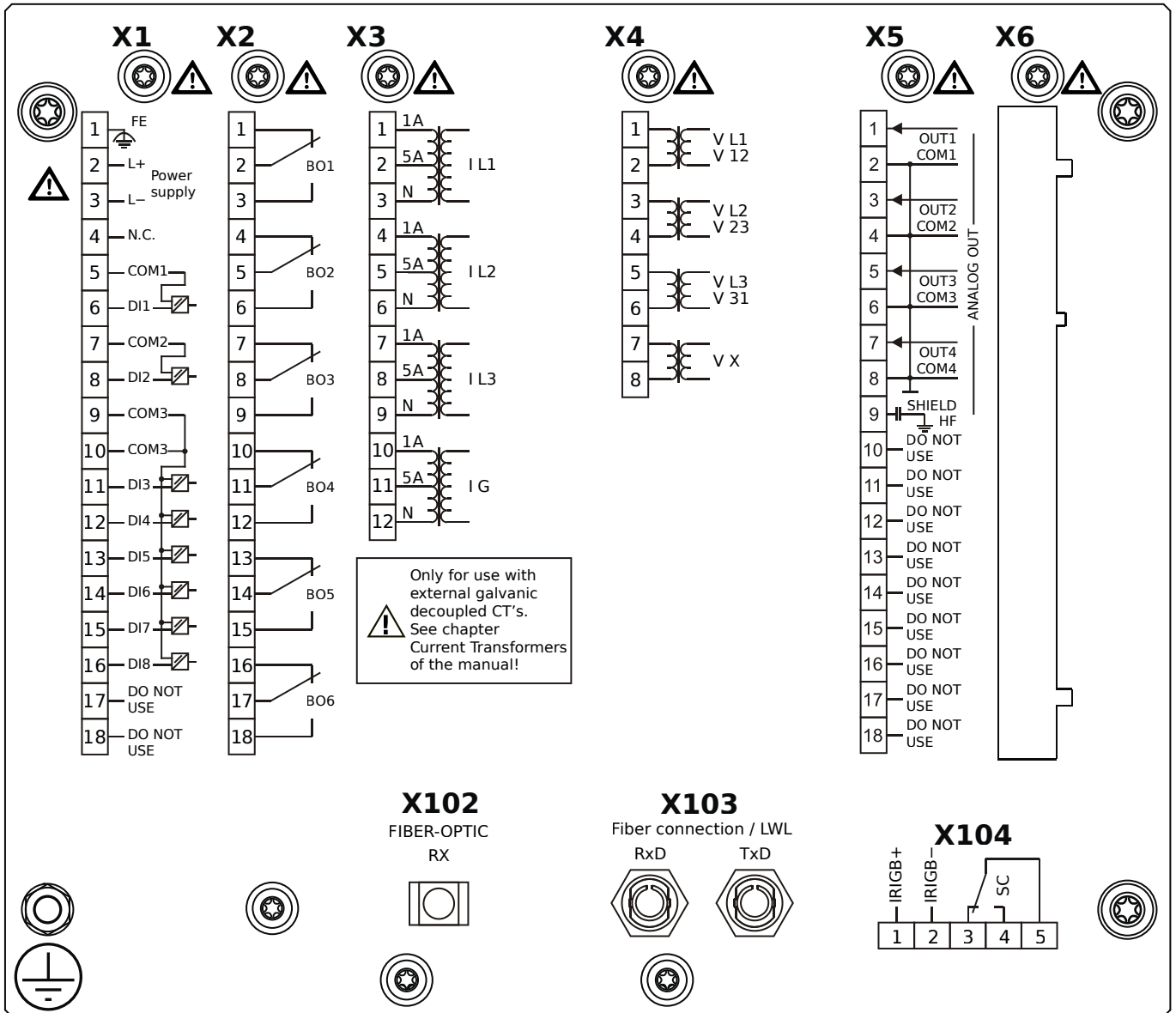

## Housing B2, small display, 19" rack mounting

+ Conformal Coating (for installations in harsh environment)

- X1** – DI8-X1: Wide-range power supply unit, incl. 2 non-grouped digital inputs and 6 grouped digital inputs
- X2** – OR6: Assembly Group with 6 Output Relays (Changeover / Form C)
- X3** – TI: Standard current measuring card
- X4** – TU: Card with 4 voltage transformer measuring inputs (0 ... 800 VAC, under UL: 0 ... 600 VAC)
- X5** – AnO4: Analog Outputs
- X102** – Universal Resistance-Temperature Detector (URTD) input, Fiber optics interface, Versatile Link
- X103** – Modbus RTU / IEC 60870-5-103 / DNP3.0 RTU, Fiber optics interface, ST Connector
- X104** – IRIG-B00X, incl. System Contact (Supervision Contact)

# MRMV4-2A0BGA

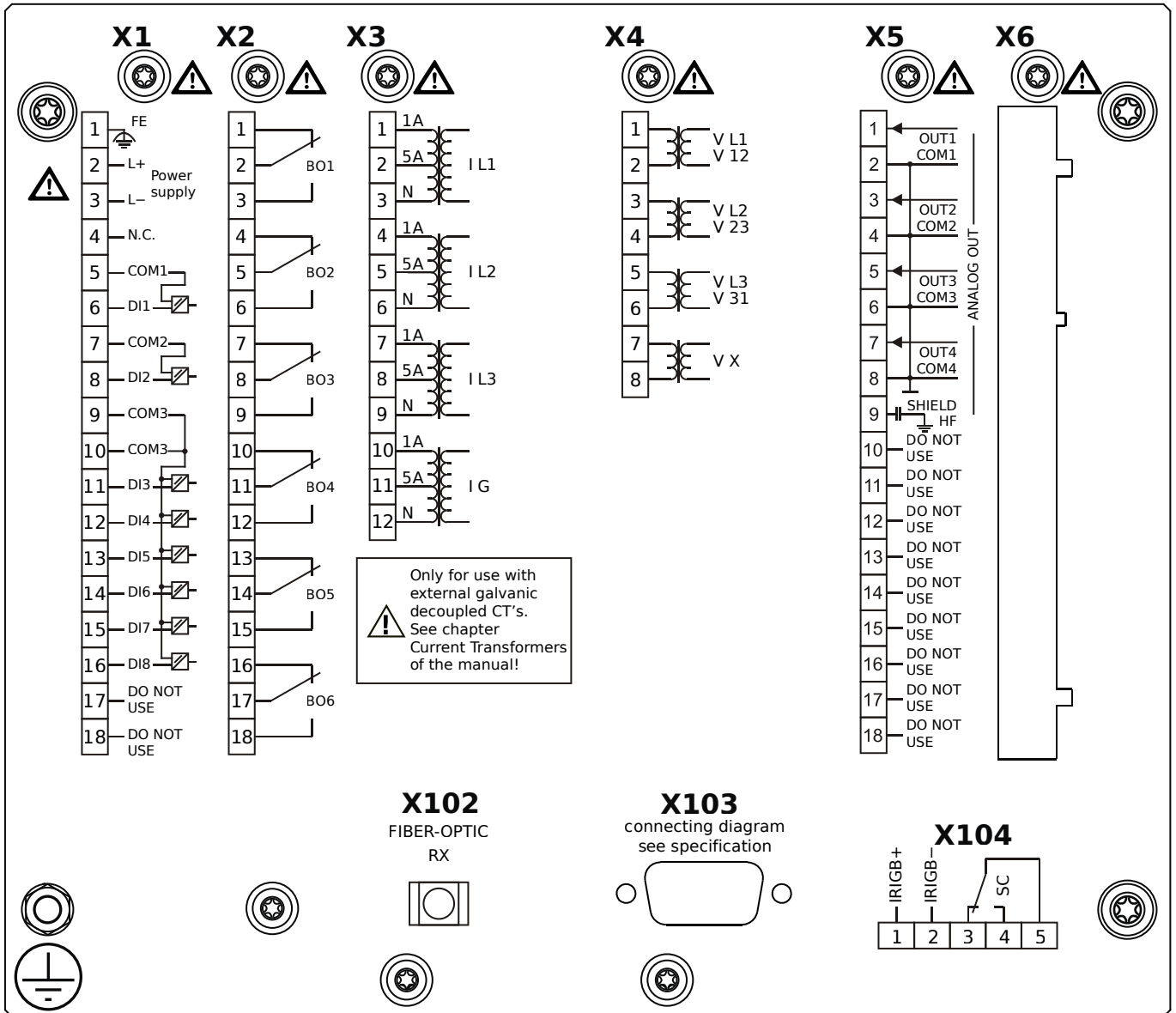

## Housing B2, small display, 19" rack mounting

- X1** – DI8-X1: Wide-range power supply unit, incl. 2 non-grouped digital inputs and 6 grouped digital inputs
- X2** – OR6: Assembly Group with 6 Output Relays (Changeover / Form C)
- X3** – TI: Standard current measuring card
- X4** – TU: Card with 4 voltage transformer measuring inputs (0 ... 800 VAC, under UL: 0 ... 600 VAC)
- X5** – AnO4: Analog Outputs
- X102** – Universal Resistance-Temperature Detector (URTD) input, Fiber optics interface, Versatile Link
- X103** – Modbus RTU / IEC 60870-5-103 / DNP3.0 RTU, RS485, D-SUB
- X104** – IRIG-B00X, incl. System Contact (Supervision Contact)

# MRMV4-2A0BGB

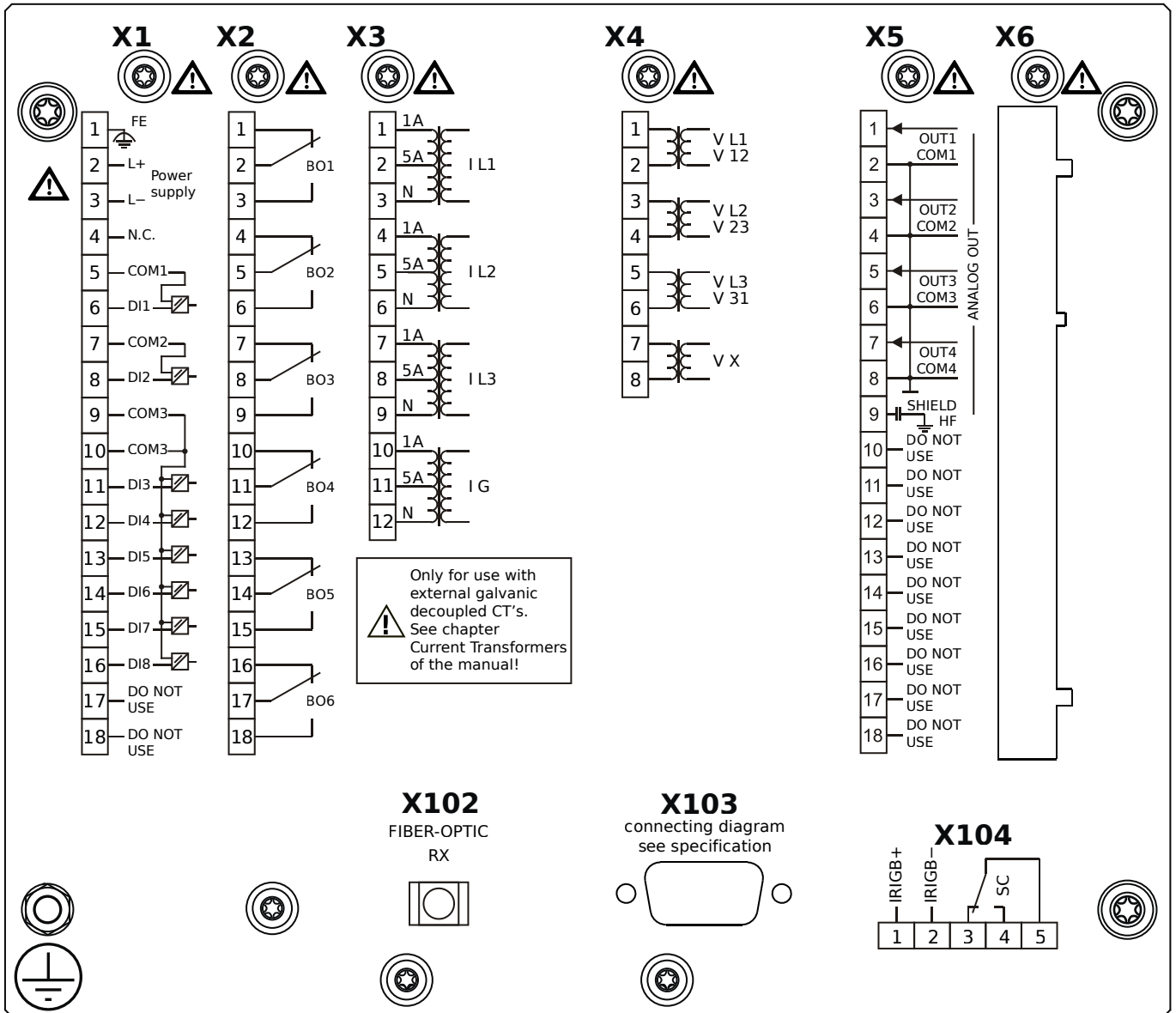

## Housing B2, small display, 19" rack mounting

+ Conformal Coating (for installations in harsh environment)

- X1** – DI8-X1: Wide-range power supply unit, incl. 2 non-grouped digital inputs and 6 grouped digital inputs
- X2** – OR6: Assembly Group with 6 Output Relays (Changeover / Form C)
- X3** – TI: Standard current measuring card
- X4** – TU: Card with 4 voltage transformer measuring inputs (0 ... 800 VAC, under UL: 0 ... 600 VAC)
- X5** – AnO4: Analog Outputs
- X102** – Universal Resistance-Temperature Detector (URTD) input, Fiber optics interface, Versatile Link
- X103** – Modbus RTU / IEC 60870-5-103 / DNP3.0 RTU, RS485, D-SUB
- X104** – IRIG-B00X, incl. System Contact (Supervision Contact)

# MRMV4-2A0BHA

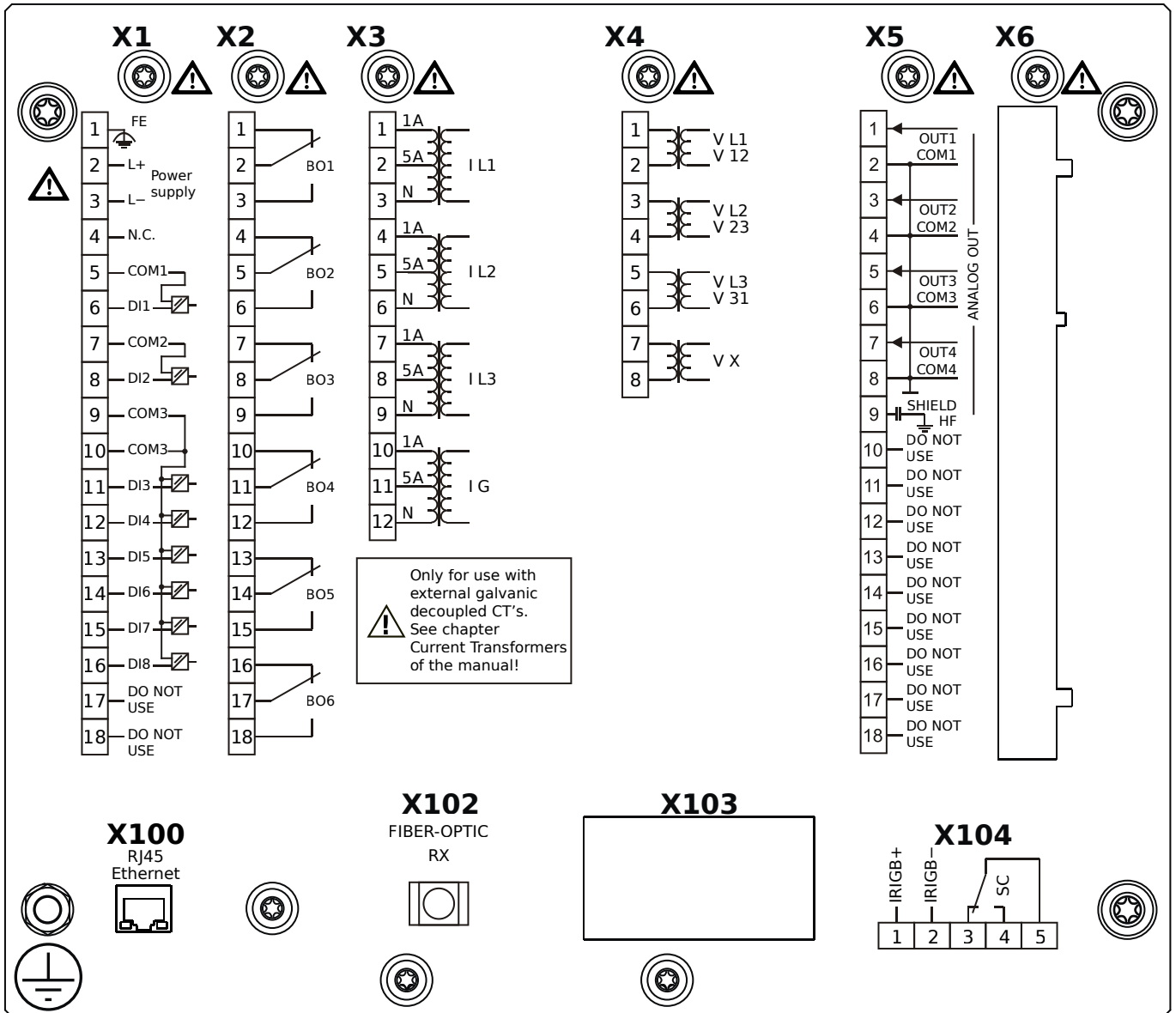

## Housing B2, small display, 19" rack mounting

- X1** – DI8-X1: Wide-range power supply unit, incl. 2 non-grouped digital inputs and 6 grouped digital inputs
- X2** – OR6: Assembly Group with 6 Output Relays (Changeover / Form C)
- X3** – TI: Standard current measuring card
- X4** – TU: Card with 4 voltage transformer measuring inputs (0 ... 800 VAC, under UL: 0 ... 600 VAC)
- X5** – AnO4: Analog Outputs
- X100** – IEC 61850 / Modbus TCP / IEC 60870-5-104 / DNP3.0 TCP/UDP, Ethernet interface, 100 Mbit/s, RJ45 (BASE100-FX)
- X102** – Universal Resistance-Temperature Detector (URTD) input, Fiber optics interface, Versatile Link
- X104** – IRIG-B00X, incl. System Contact (Supervision Contact)



# MRMV4-2A0BHB

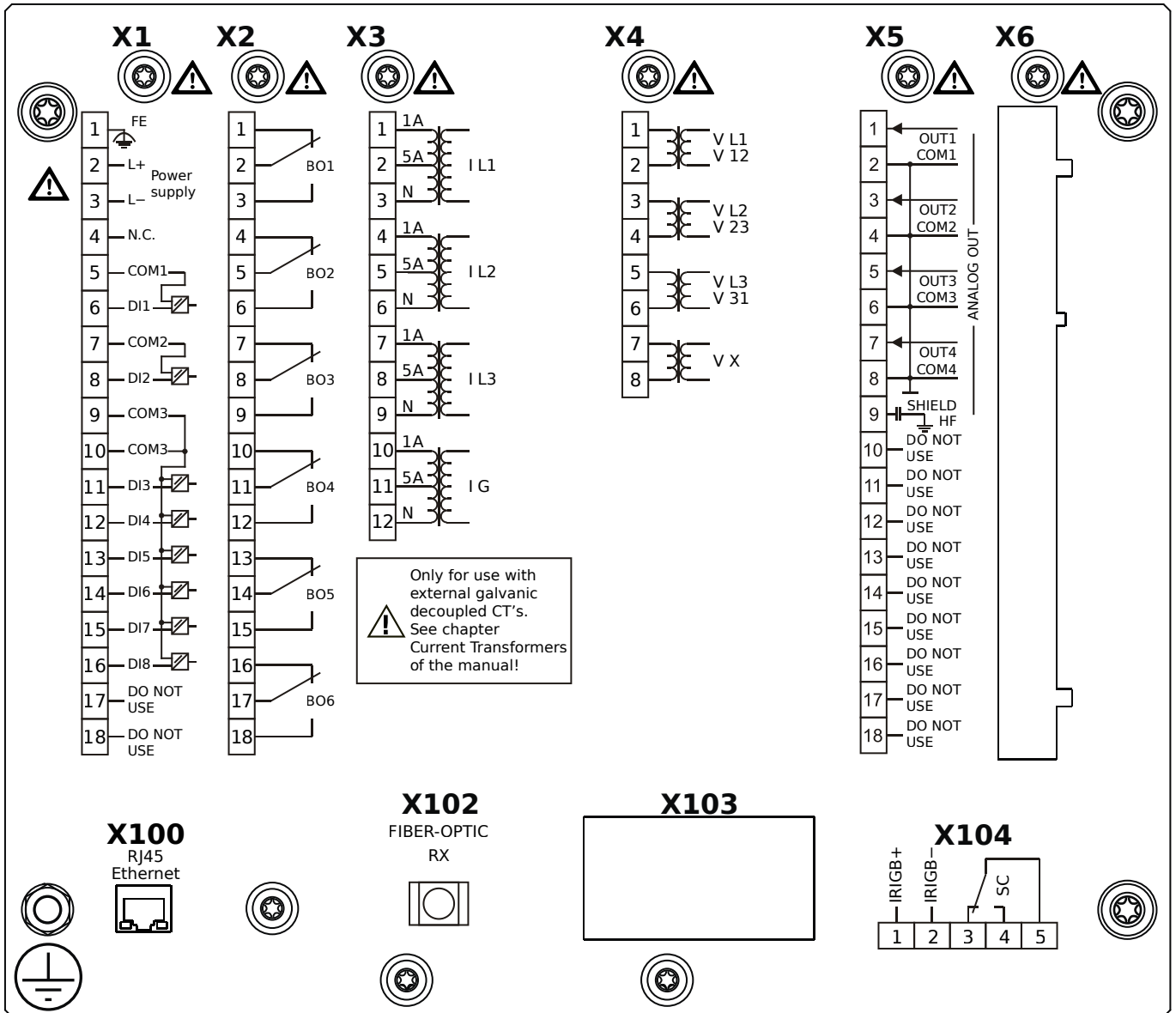

## Housing B2, small display, 19" rack mounting

+ Conformal Coating (for installations in harsh environment)

**X1** – DI8-X1: Wide-range power supply unit, incl. 2 non-grouped digital inputs and 6 grouped digital inputs

**X2** – OR6: Assembly Group with 6 Output Relays (Changeover / Form C)

**X3** – TI: Standard current measuring card

**X4** – TU: Card with 4 voltage transformer measuring inputs (0 ... 800 VAC, under UL: 0 ... 600 VAC)

**X5** – AnO4: Analog Outputs

**X100** – IEC 61850 / Modbus TCP / IEC 60870-5-104 / DNP3.0 TCP/UDP, Ethernet interface, 100 Mbit/s, RJ45 (BASE100-

FX)

**X102** – Universal Resistance-Temperature Detector (URTD) input, Fiber optics interface, Versatile Link

**X104** – IRIG-B00X, incl. System Contact (Supervision Contact)

# MRMV4-2A0BIA

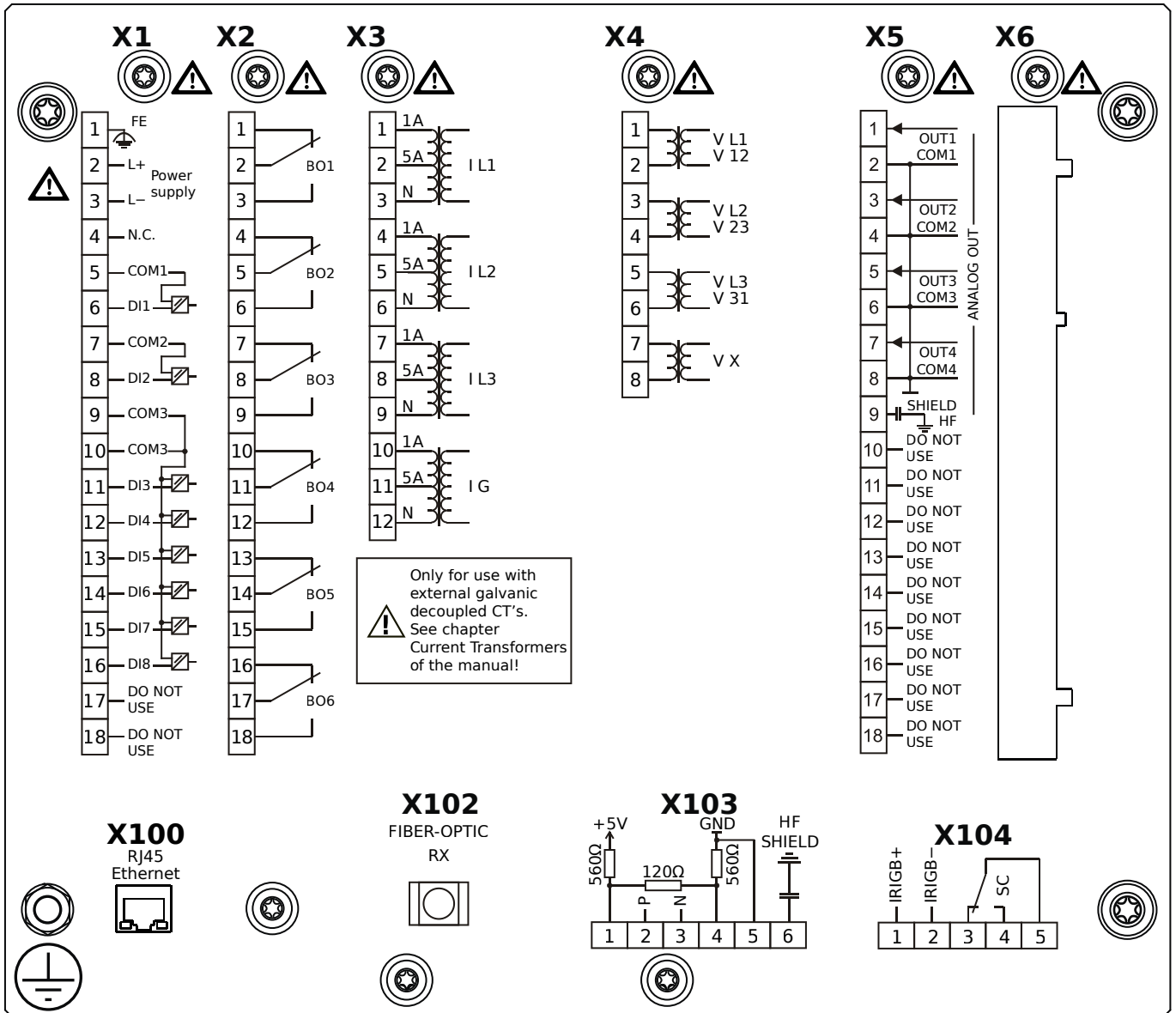

## Housing B2, small display, 19" rack mounting

- X1** – DI8-X1: Wide-range power supply unit, incl. 2 non-grouped digital inputs and 6 grouped digital inputs
- X2** – OR6: Assembly Group with 6 Output Relays (Changeover / Form C)
- X3** – TI: Standard current measuring card
- X4** – TU: Card with 4 voltage transformer measuring inputs (0 ... 800 VAC, under UL: 0 ... 600 VAC)
- X5** – AnO4: Analog Outputs
- X100** – Modbus TCP / IEC 60870-5-104 / DNP3.0 TCP/UDP, Ethernet interface, 100 Mbit/s, RJ45 (BASE100-FX)
- X102** – Universal Resistance-Temperature Detector (URTD) input, Fiber optics interface, Versatile Link
- X103** – IEC 60870-5-103 / Modbus RTU / DNP3.0 RTU, RS485, Terminals
- X104** – IRIG-B00X, incl. System Contact (Supervision Contact)

# MRMV4-2A0BIB

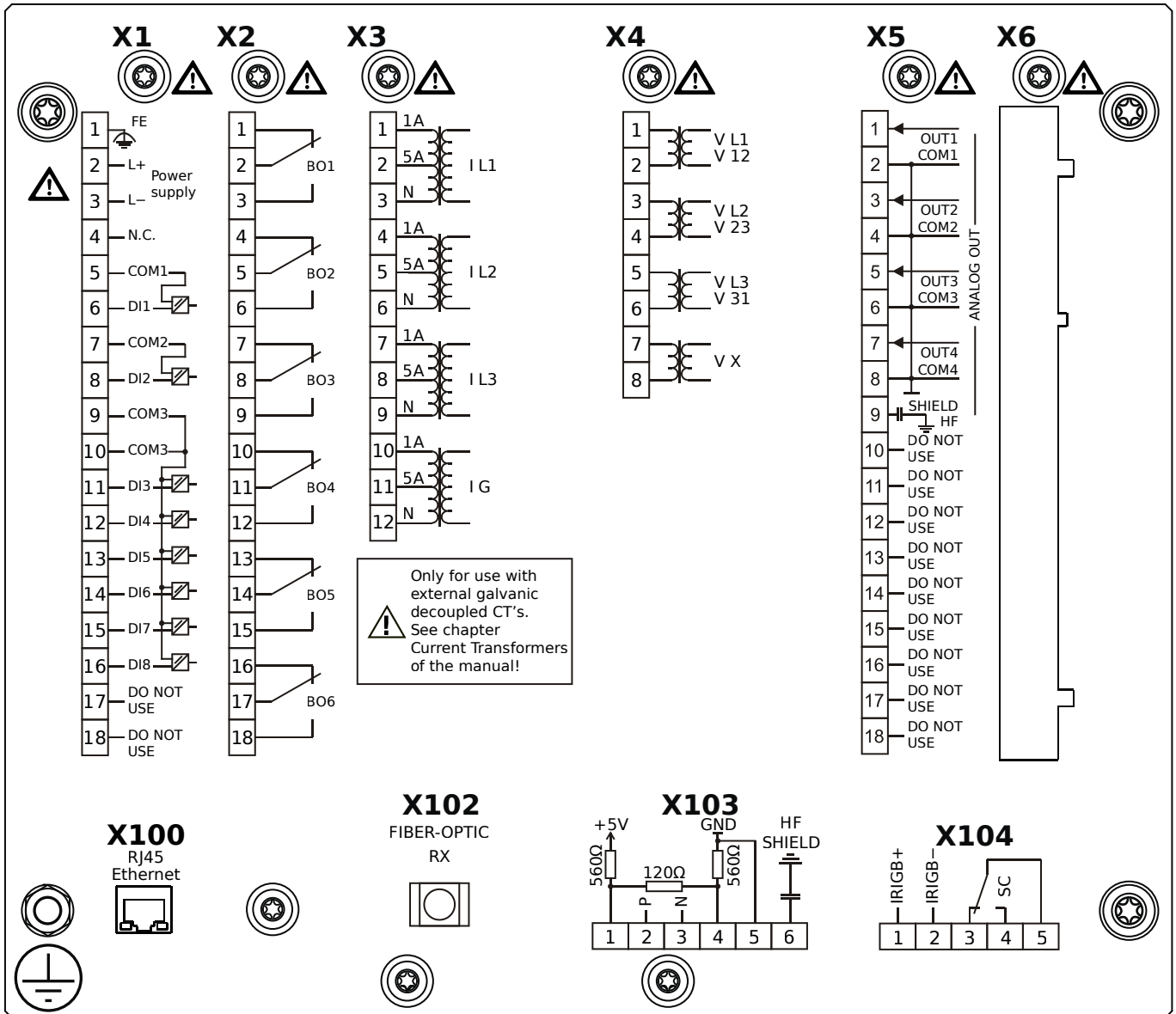

## Housing B2, small display, 19" rack mounting

+ Conformal Coating (for installations in harsh environment)

- X1** – DI8-X1: Wide-range power supply unit, incl. 2 non-grouped digital inputs and 6 grouped digital inputs
- X2** – OR6: Assembly Group with 6 Output Relays (Changeover / Form C)
- X3** – TI: Standard current measuring card
- X4** – TU: Card with 4 voltage transformer measuring inputs (0 ... 800 VAC, under UL: 0 ... 600 VAC)
- X5** – AnO4: Analog Outputs
- X100** – Modbus TCP / IEC 60870-5-104 / DNP3.0 TCP/UDP, Ethernet interface, 100 Mbit/s, RJ45 (BASE100-FX)
- X102** – Universal Resistance-Temperature Detector (URTD) input, Fiber optics interface, Versatile Link
- X103** – IEC 60870-5-103 / Modbus RTU / DNP3.0 RTU, RS485, Terminals
- X104** – IRIG-B00X, incl. System Contact (Supervision Contact)

# MRMV4-2A0BKA

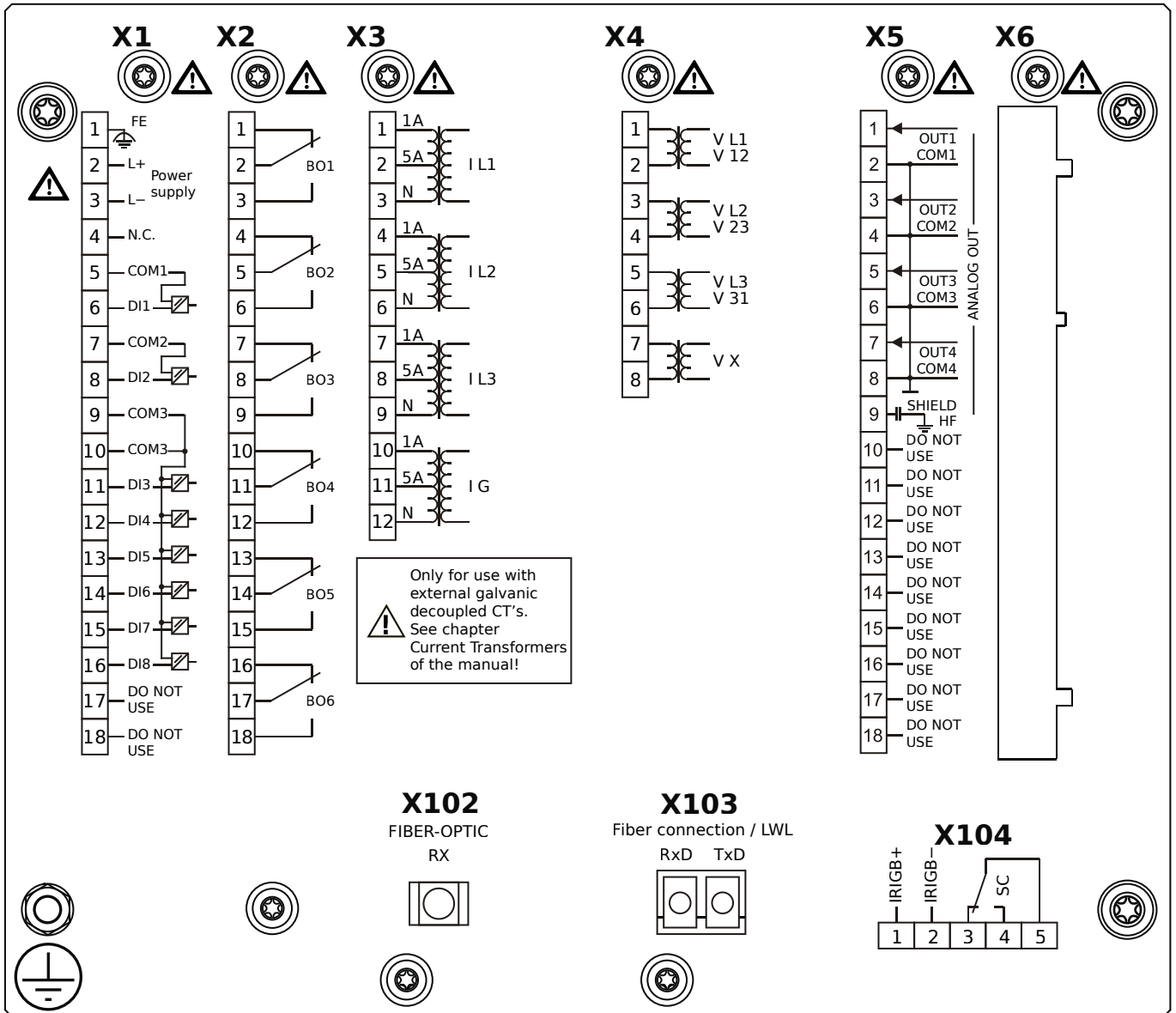

## Housing B2, small display, 19" rack mounting

- X1** – DI8-X1: Wide-range power supply unit, incl. 2 non-grouped digital inputs and 6 grouped digital inputs
- X2** – OR6: Assembly Group with 6 Output Relays (Changeover / Form C)
- X3** – TI: Standard current measuring card
- X4** – TU: Card with 4 voltage transformer measuring inputs (0 ... 800 VAC, under UL: 0 ... 600 VAC)
- X5** – AnO4: Analog Outputs
- X102** – Universal Resistance-Temperature Detector (URTD) input, Fiber optics interface, Versatile Link
- X103** – IEC 61850 / Modbus TCP / IEC 60870-5-104 / DNP3.0 TCP/UDP, Fiber optics interface, LC Connector
- X104** – IRIG-B00X, incl. System Contact (Supervision Contact)

# MRMV4-2A0BKB

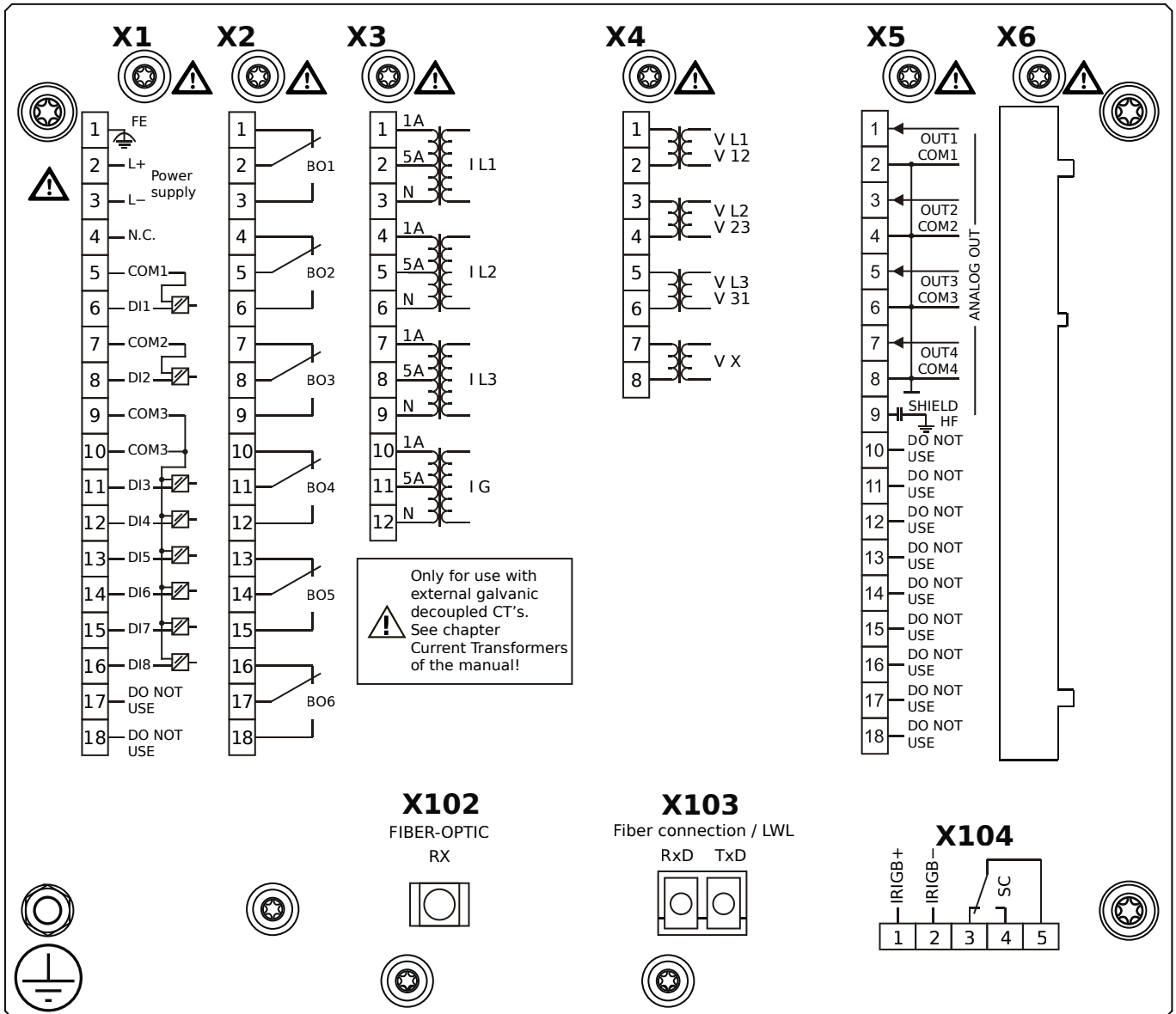

## Housing B2, small display, 19" rack mounting

+ Conformal Coating (for installations in harsh environment)

- X1** – DI8-X1: Wide-range power supply unit, incl. 2 non-grouped digital inputs and 6 grouped digital inputs
- X2** – OR6: Assembly Group with 6 Output Relays (Changeover / Form C)
- X3** – TI: Standard current measuring card
- X4** – TU: Card with 4 voltage transformer measuring inputs (0 ... 800 VAC, under UL: 0 ... 600 VAC)
- X5** – AnO4: Analog Outputs
- X102** – Universal Resistance-Temperature Detector (URTD) input, Fiber optics interface, Versatile Link
- X103** – IEC 61850 / Modbus TCP / IEC 60870-5-104 / DNP3.0 TCP/UDP, Fiber optics interface, LC Connector
- X104** – IRIG-B00X, incl. System Contact (Supervision Contact)

# MRMV4-2A0BLA

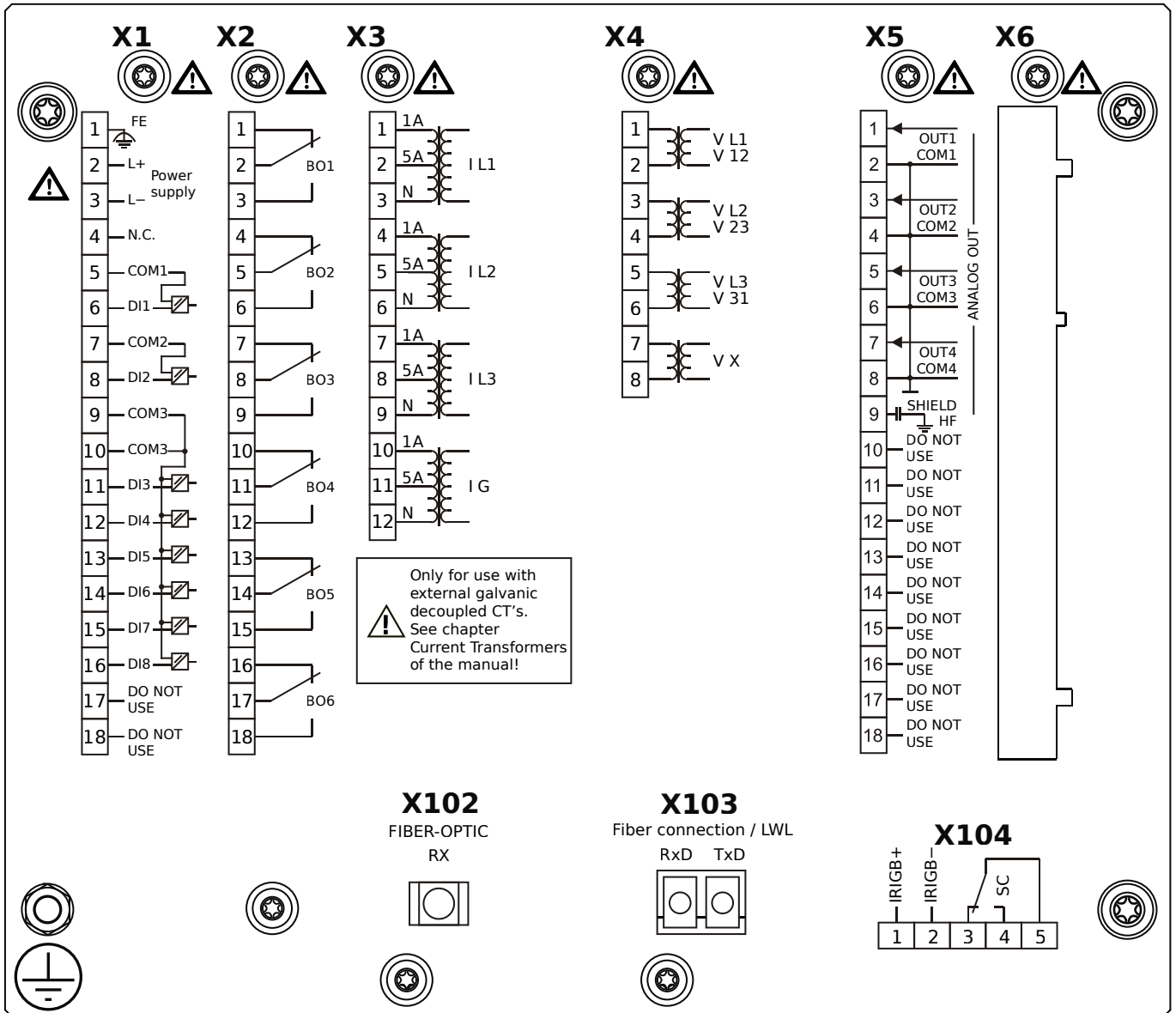

## Housing B2, small display, 19" rack mounting

- X1** – DI8-X1: Wide-range power supply unit, incl. 2 non-grouped digital inputs and 6 grouped digital inputs
- X2** – OR6: Assembly Group with 6 Output Relays (Changeover / Form C)
- X3** – TI: Standard current measuring card
- X4** – TU: Card with 4 voltage transformer measuring inputs (0 ... 800 VAC, under UL: 0 ... 600 VAC)
- X5** – AnO4: Analog Outputs
- X102** – Universal Resistance-Temperature Detector (URTD) input, Fiber optics interface, Versatile Link
- X103** – Modbus TCP / IEC 60870-5-104 / DNP3.0 TCP/UDP, Fiber optics interface, LC Connector
- X104** – IRIG-B00X, incl. System Contact (Supervision Contact)

# MRMV4-2A0BLB

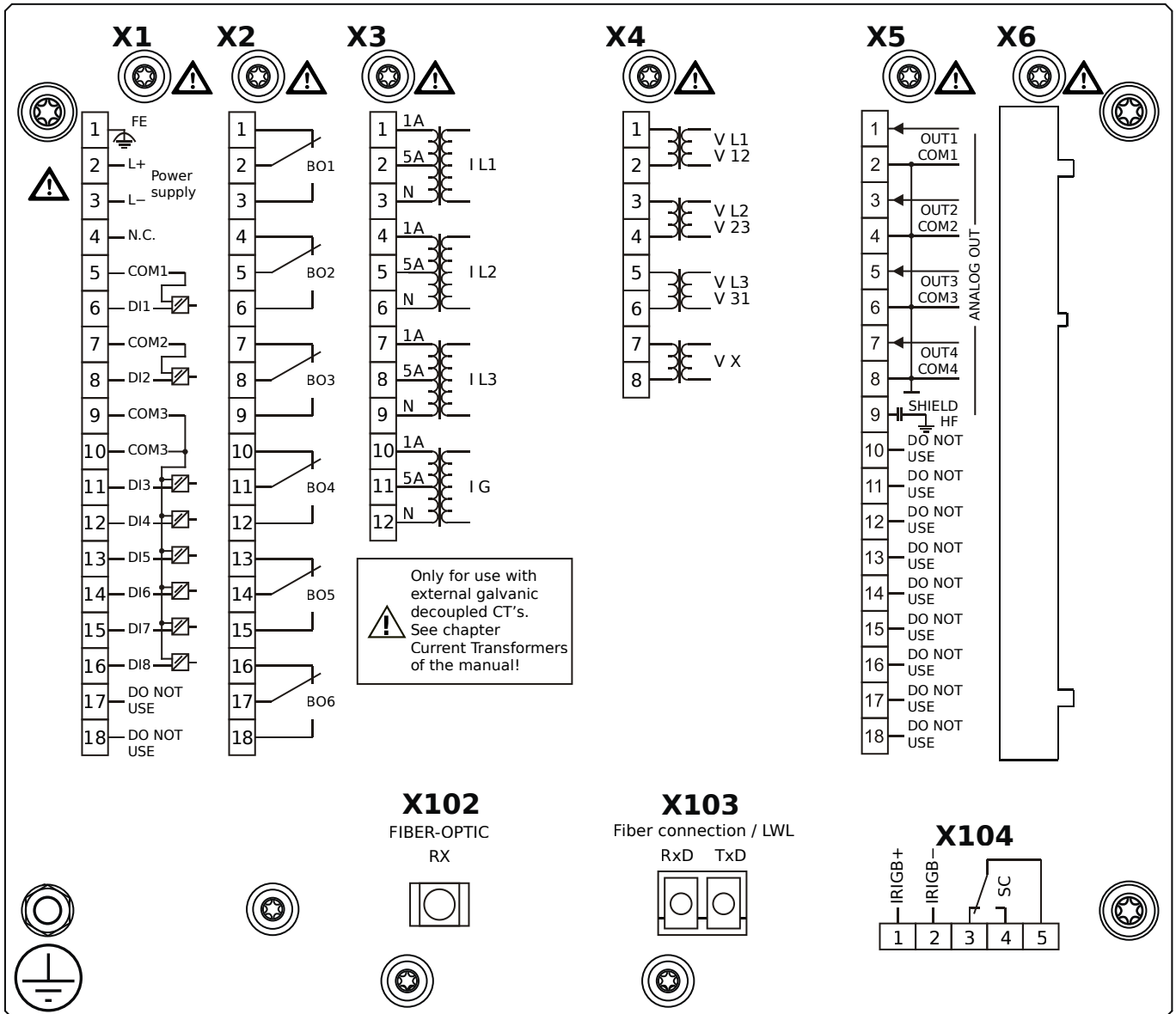

## Housing B2, small display, 19" rack mounting

+ Conformal Coating (for installations in harsh environment)

- X1** – DI8-X1: Wide-range power supply unit, incl. 2 non-grouped digital inputs and 6 grouped digital inputs
- X2** – OR6: Assembly Group with 6 Output Relays (Changeover / Form C)
- X3** – TI: Standard current measuring card
- X4** – TU: Card with 4 voltage transformer measuring inputs (0 ... 800 VAC, under UL: 0 ... 600 VAC)
- X5** – AnO4: Analog Outputs
- X102** – Universal Resistance-Temperature Detector (URTD) input, Fiber optics interface, Versatile Link
- X103** – Modbus TCP / IEC 60870-5-104 / DNP3.0 TCP/UDP, Fiber optics interface, LC Connector
- X104** – IRIG-B00X, incl. System Contact (Supervision Contact)

# MRMV4-2A0BOA

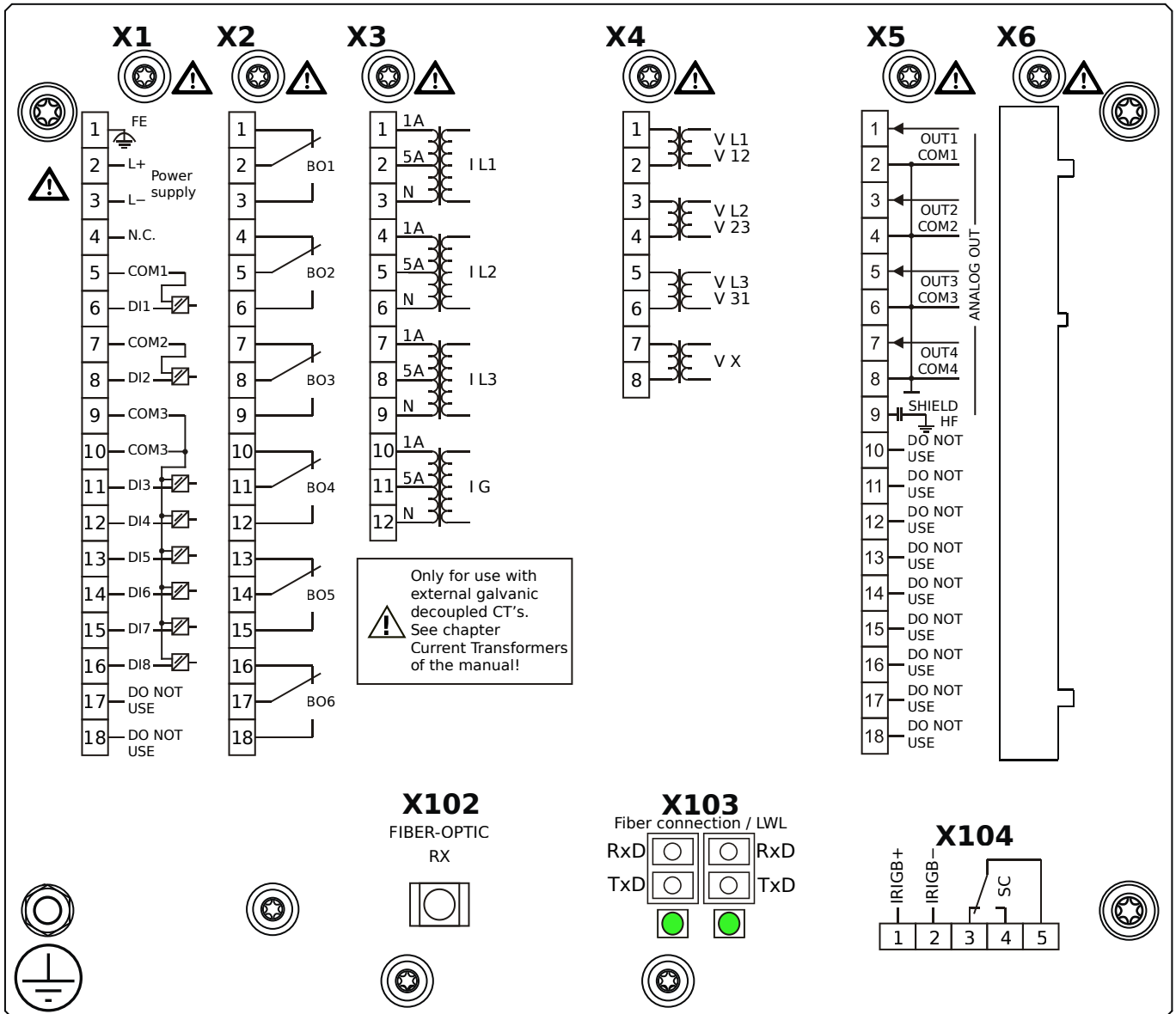

## Housing B2, small display, 19" rack mounting

- X1** – DI8-X1: Wide-range power supply unit, incl. 2 non-grouped digital inputs and 6 grouped digital inputs
- X2** – OR6: Assembly Group with 6 Output Relays (Changeover / Form C)
- X3** – TI: Standard current measuring card
- X4** – TU: Card with 4 voltage transformer measuring inputs (0 ... 800 VAC, under UL: 0 ... 600 VAC)
- X5** – AnO4: Analog Outputs
- X102** – Universal Resistance-Temperature Detector (URTD) input, Fiber optics interface, Versatile Link
- X103** – Modbus TCP / IEC 60870-5-104 / DNP3.0 TCP/UDP, Redundant Fiber optics interface, LC Connector
- X104** – IRIG-B00X, incl. System Contact (Supervision Contact)



# MRMV4-2A0BOB

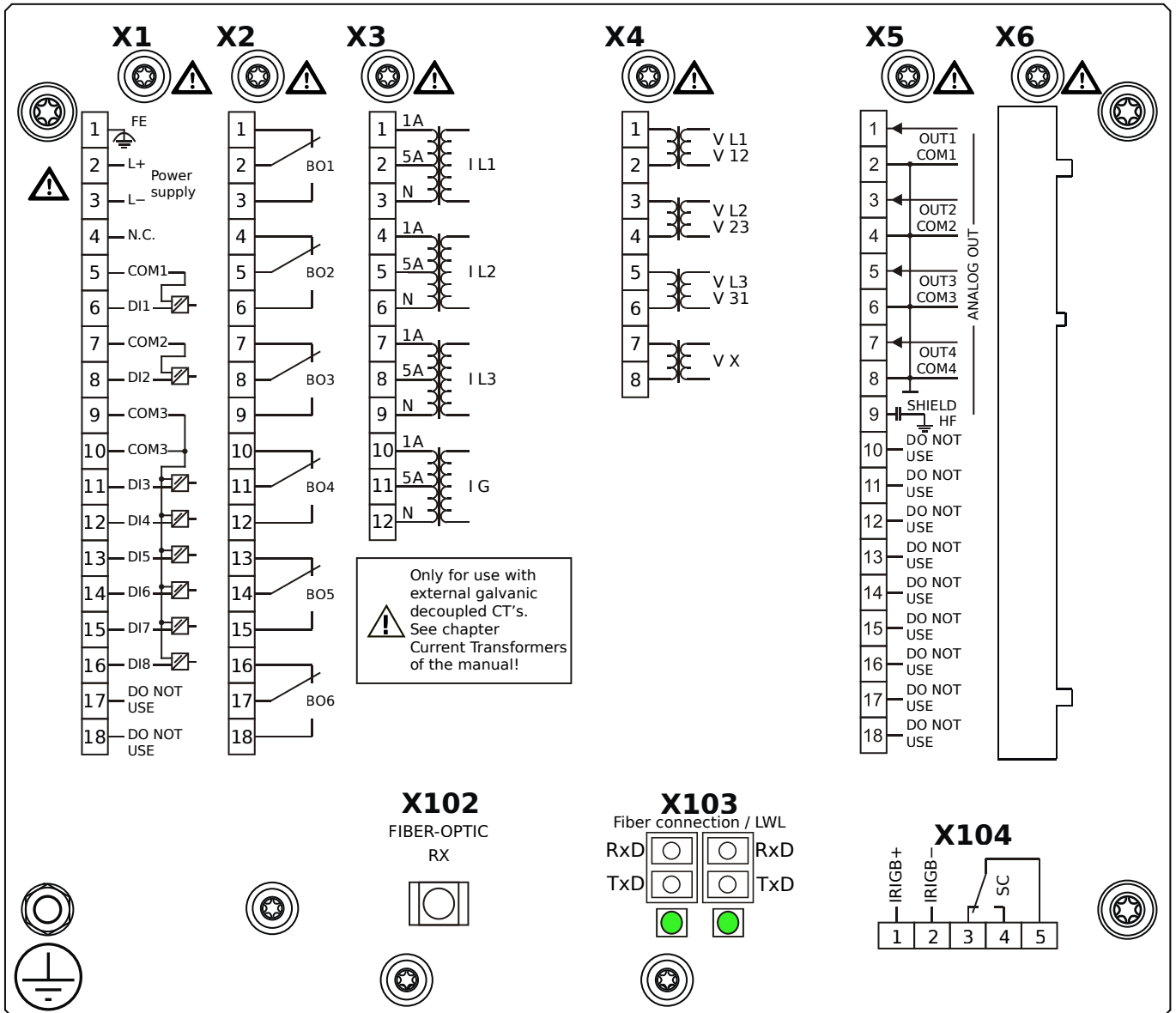

## Housing B2, small display, 19" rack mounting

- + Conformal Coating (for installations in harsh environment)

- X1** – DI8-X1: Wide-range power supply unit, incl. 2 non-grouped digital inputs and 6 grouped digital inputs
- X2** – OR6: Assembly Group with 6 Output Relays (Changeover / Form C)
- X3** – TI: Standard current measuring card
- X4** – TU: Card with 4 voltage transformer measuring inputs (0 ... 800 VAC, under UL: 0 ... 600 VAC)
- X5** – AnO4: Analog Outputs
- X102** – Universal Resistance-Temperature Detector (URTD) input, Fiber optics interface, Versatile Link
- X103** – Modbus TCP / IEC 60870-5-104 / DNP3.0 TCP/UDP, Redundant Fiber optics interface, LC Connector
- X104** – IRIG-B00X, incl. System Contact (Supervision Contact)

# MRMV4-2A0BPA

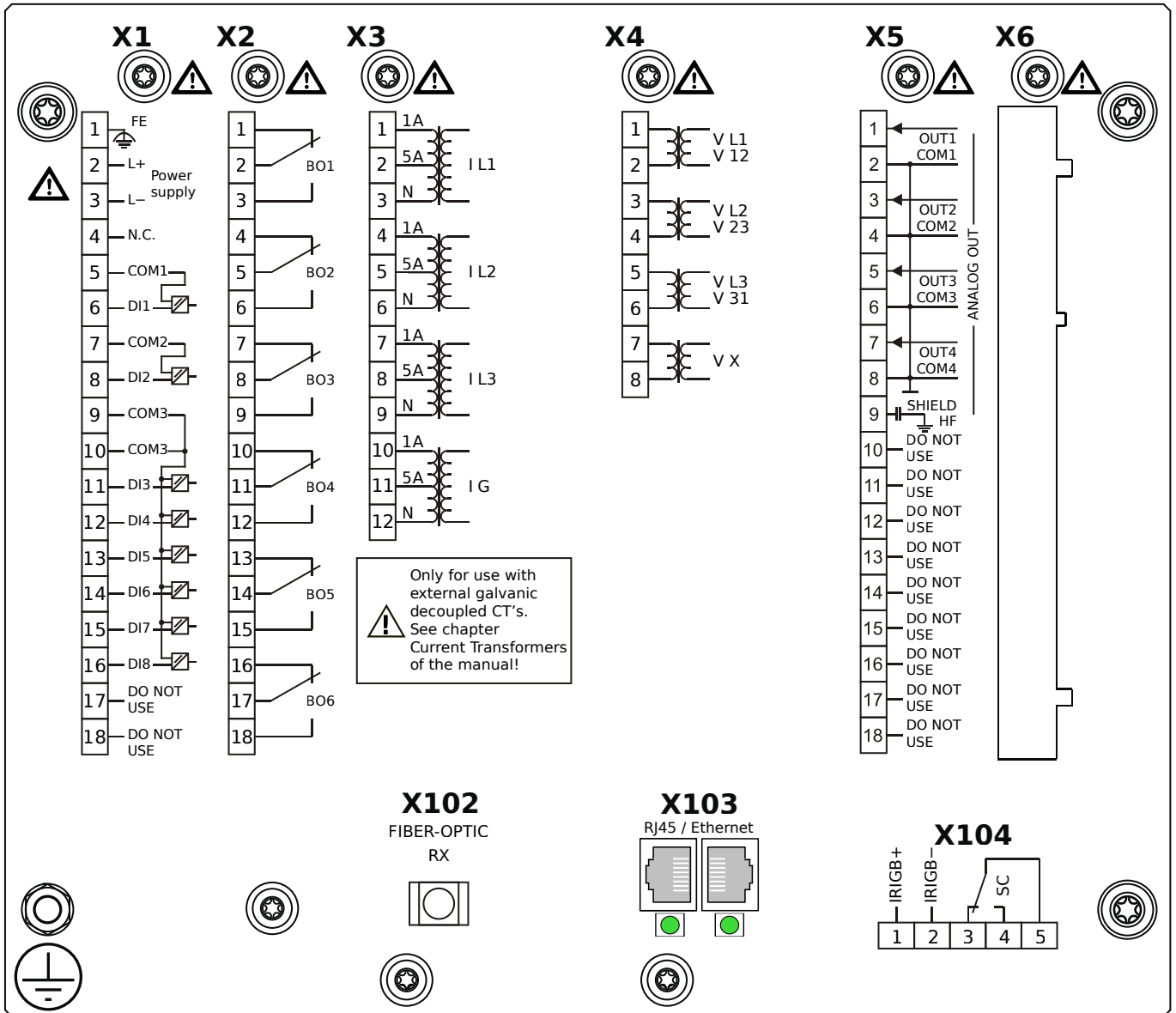

## Housing B2, small display, 19" rack mounting

- X1** – DI8-X1: Wide-range power supply unit, incl. 2 non-grouped digital inputs and 6 grouped digital inputs
- X2** – OR6: Assembly Group with 6 Output Relays (Changeover / Form C)
- X3** – TI: Standard current measuring card
- X4** – TU: Card with 4 voltage transformer measuring inputs (0 ... 800 VAC, under UL: 0 ... 600 VAC)
- X5** – AnO4: Analog Outputs
- X102** – Universal Resistance-Temperature Detector (URTD) input, Fiber optics interface, Versatile Link
- X103** – Modbus TCP / IEC 60870-5-104 / DNP3.0 TCP/UDP, Redundant Ethernet interface, 100 Mbit/s, RJ45 (BASE100-FX)
- X104** – IRIG-B00X, incl. System Contact (Supervision Contact)

# MRMV4-2A0BPB

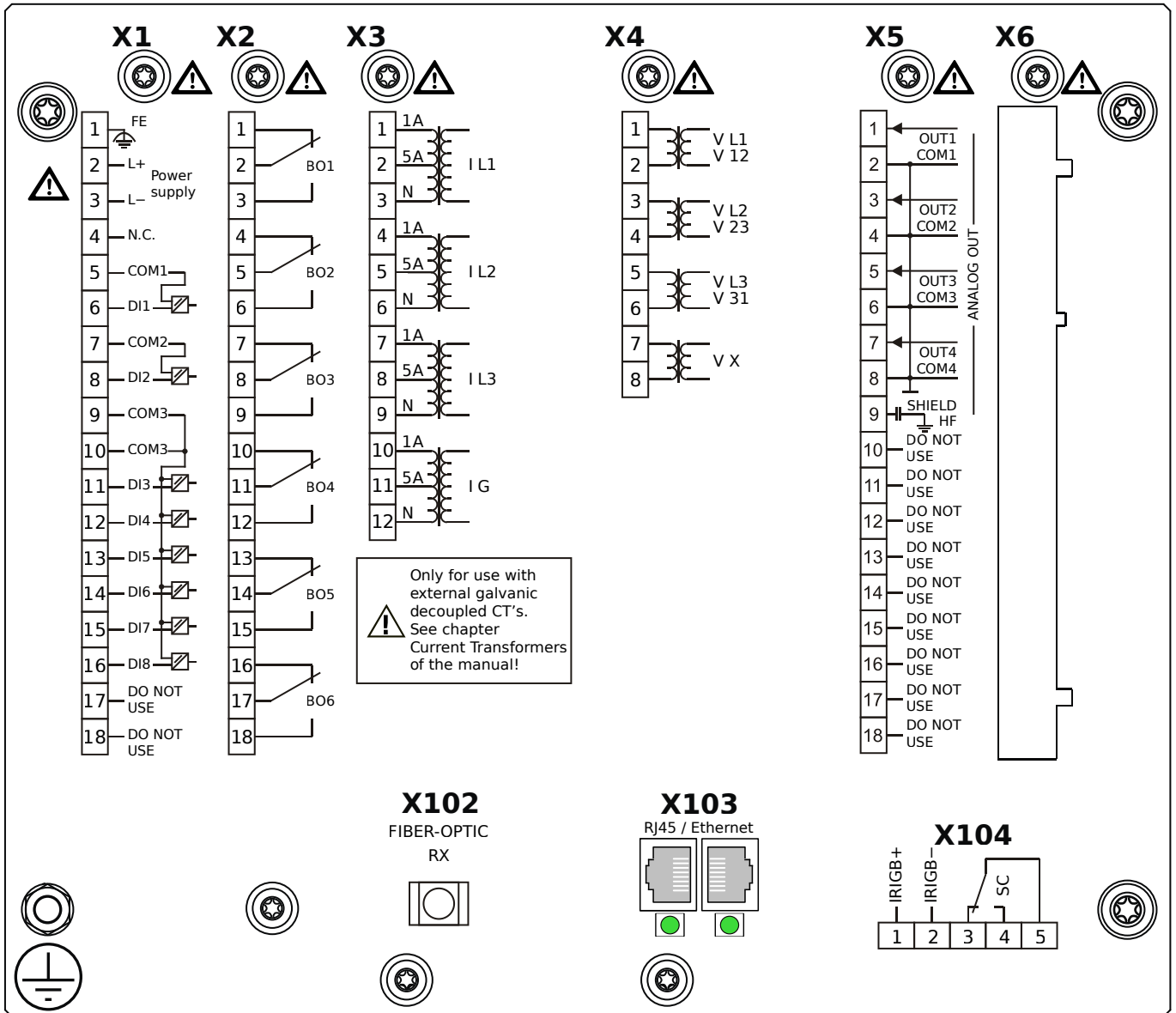

## Housing B2, small display, 19" rack mounting

- + Conformal Coating (for installations in harsh environment)

- X1** – DI8-X1: Wide-range power supply unit, incl. 2 non-grouped digital inputs and 6 grouped digital inputs
- X2** – OR6: Assembly Group with 6 Output Relays (Changeover / Form C)
- X3** – TI: Standard current measuring card
- X4** – TU: Card with 4 voltage transformer measuring inputs (0 ... 800 VAC, under UL: 0 ... 600 VAC)
- X5** – AnO4: Analog Outputs
- X102** – Universal Resistance-Temperature Detector (URTD) input, Fiber optics interface, Versatile Link
- X103** – Modbus TCP / IEC 60870-5-104 / DNP3.0 TCP/UDP, Redundant Ethernet interface, 100 Mbit/s, RJ45 (BASE100-FX)
- X104** – IRIG-B00X, incl. System Contact (Supervision Contact)

# MRMV4-2A0BQA

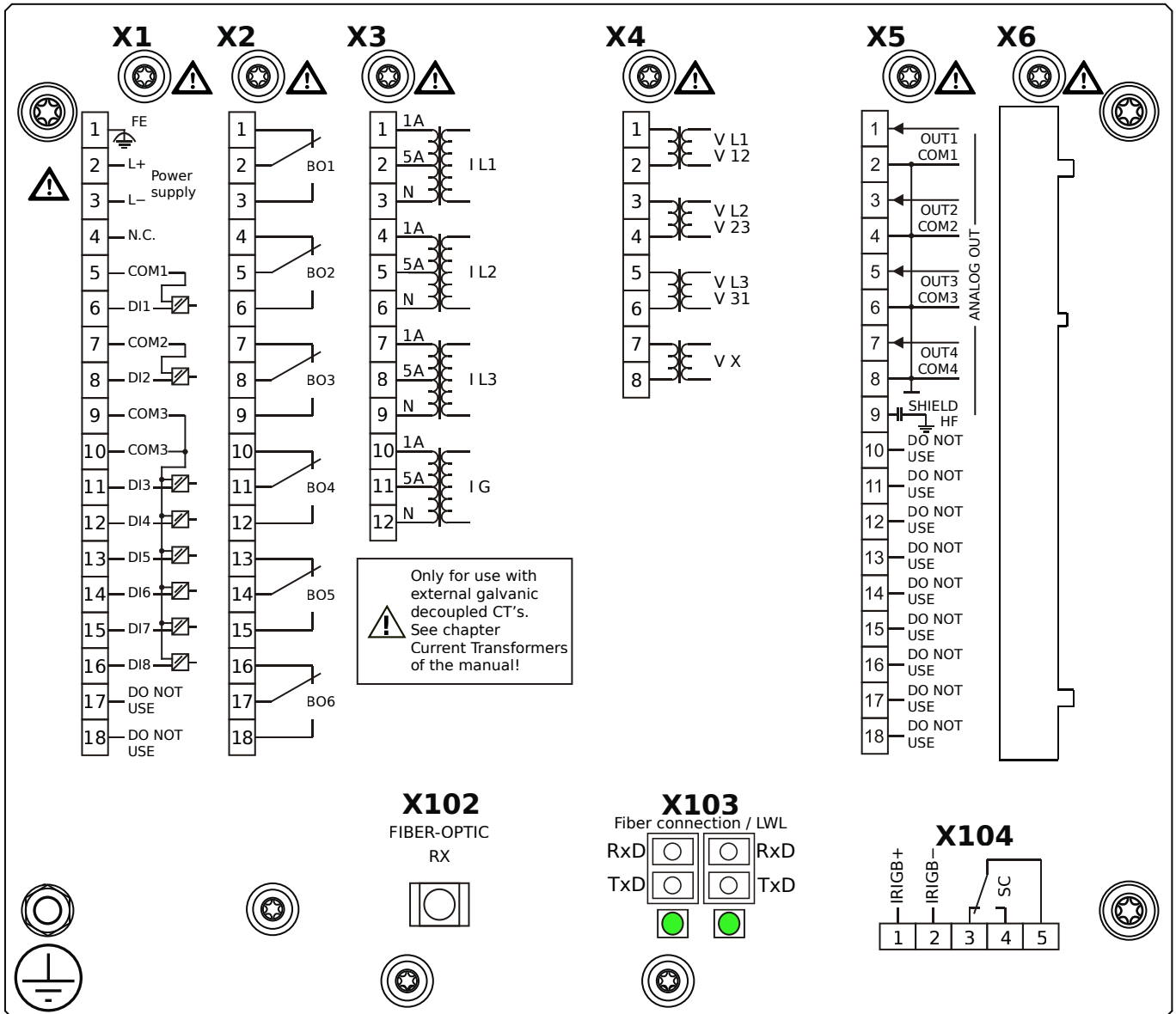

## Housing B2, small display, 19" rack mounting

- X1** – DI8-X1: Wide-range power supply unit, incl. 2 non-grouped digital inputs and 6 grouped digital inputs
- X2** – OR6: Assembly Group with 6 Output Relays (Changeover / Form C)
- X3** – TI: Standard current measuring card
- X4** – TU: Card with 4 voltage transformer measuring inputs (0 ... 800 VAC, under UL: 0 ... 600 VAC)
- X5** – AnO4: Analog Outputs
- X102** – Universal Resistance-Temperature Detector (URTD) input, Fiber optics interface, Versatile Link
- X103** – IEC 61850 / Modbus TCP / IEC 60870-5-104 / DNP3.0 TCP/UDP, Redundant Fiber optics interface, LC Connector
- X104** – IRIG-B00X, incl. System Contact (Supervision Contact)

# MRMV4-2A0BQB

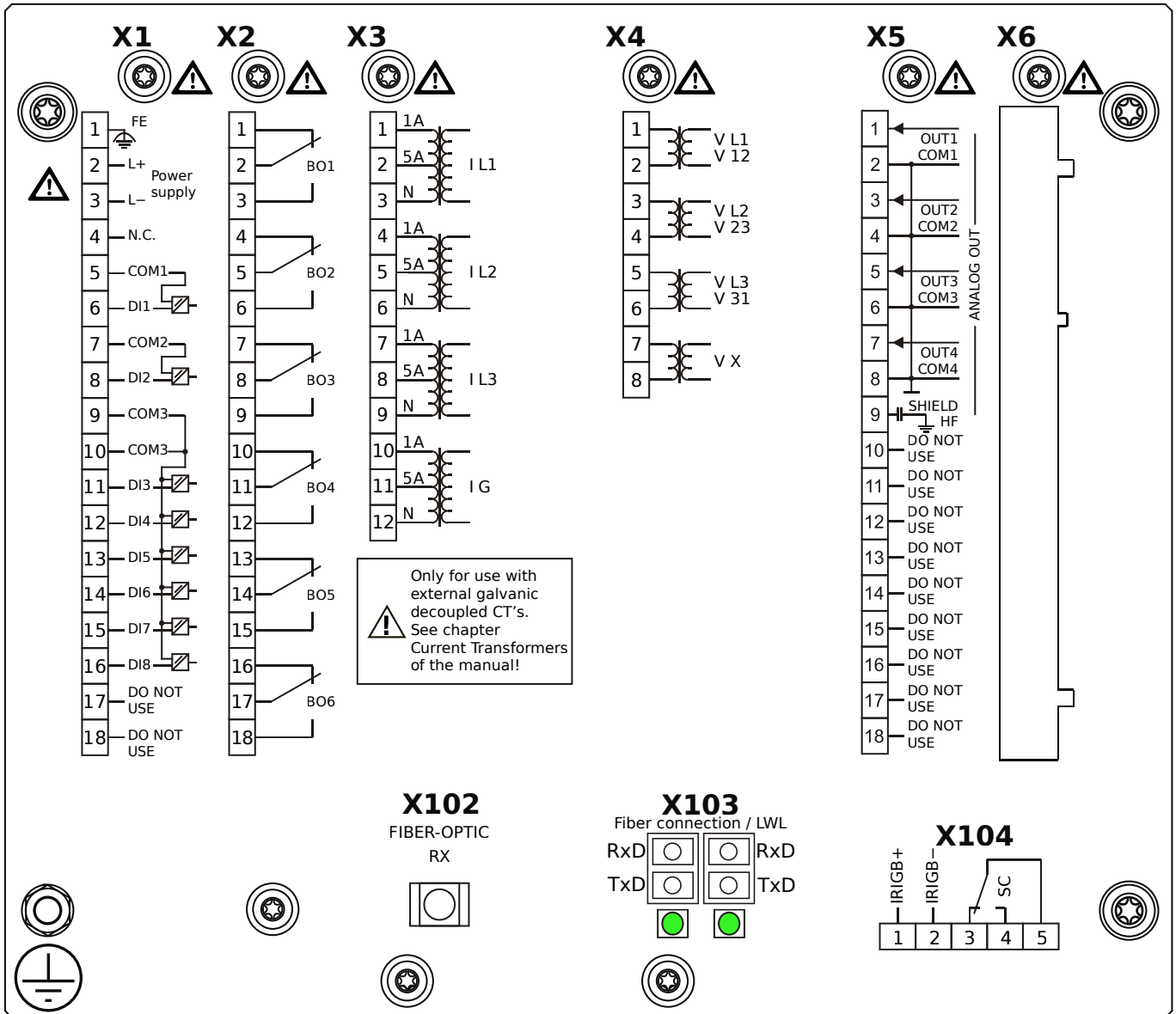

## Housing B2, small display, 19" rack mounting

- + Conformal Coating (for installations in harsh environment)

- X1** – DI8-X1: Wide-range power supply unit, incl. 2 non-grouped digital inputs and 6 grouped digital inputs
- X2** – OR6: Assembly Group with 6 Output Relays (Changeover / Form C)
- X3** – TI: Standard current measuring card
- X4** – TU: Card with 4 voltage transformer measuring inputs (0 ... 800 VAC, under UL: 0 ... 600 VAC)
- X5** – AnO4: Analog Outputs
- X102** – Universal Resistance-Temperature Detector (URTD) input, Fiber optics interface, Versatile Link
- X103** – IEC 61850 / Modbus TCP / IEC 60870-5-104 / DNP3.0 TCP/UDP, Redundant Fiber optics interface, LC Connector
- X104** – IRIG-B00X, incl. System Contact (Supervision Contact)

# MRMV4-2A0BRA

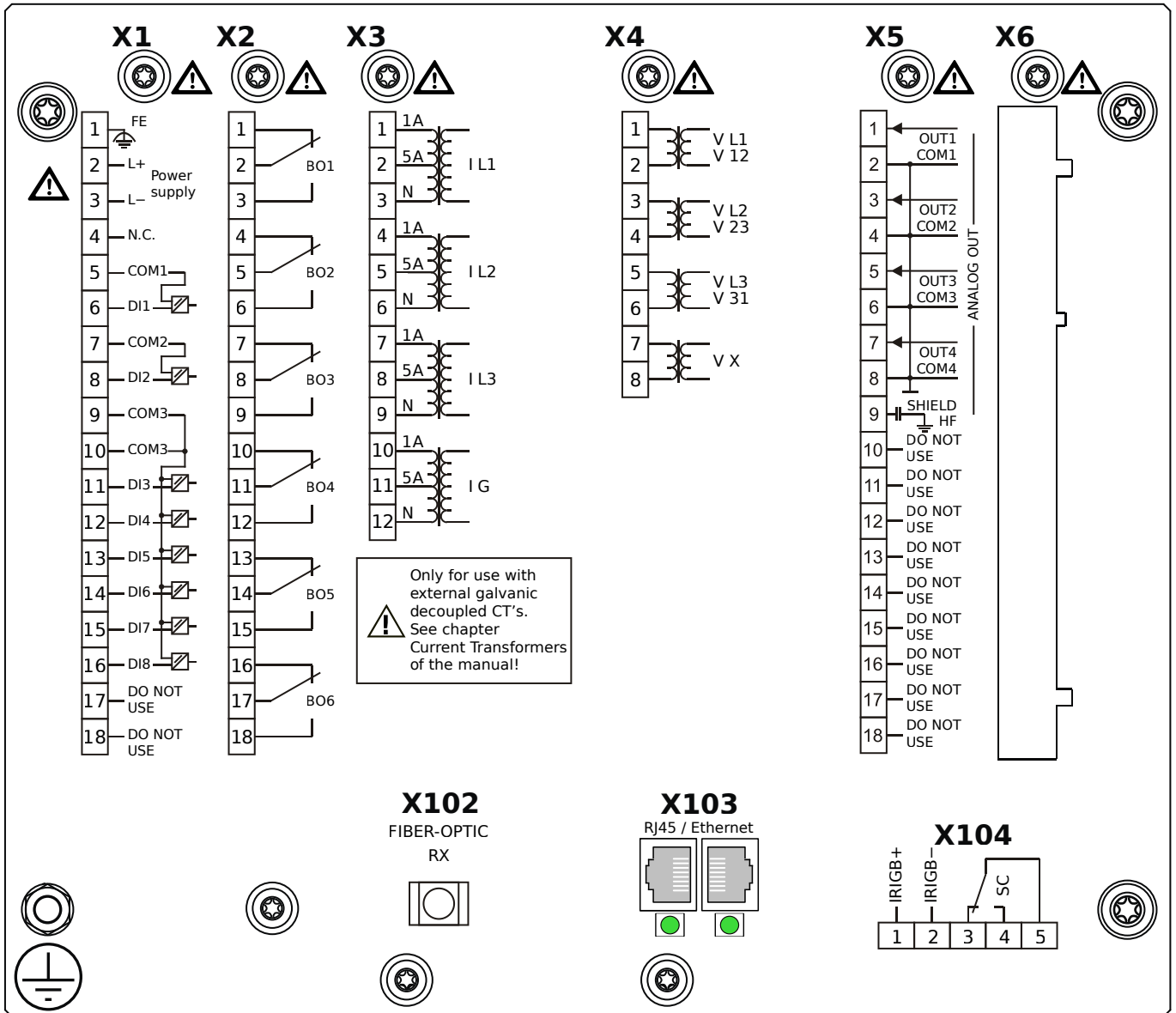

## Housing B2, small display, 19" rack mounting

- X1** – DI8-X1: Wide-range power supply unit, incl. 2 non-grouped digital inputs and 6 grouped digital inputs
- X2** – OR6: Assembly Group with 6 Output Relays (Changeover / Form C)
- X3** – TI: Standard current measuring card
- X4** – TU: Card with 4 voltage transformer measuring inputs (0 ... 800 VAC, under UL: 0 ... 600 VAC)
- X5** – AnO4: Analog Outputs
- X102** – Universal Resistance-Temperature Detector (URTD) input, Fiber optics interface, Versatile Link
- X103** – IEC 61850 / Modbus TCP / IEC 60870-5-104 / DNP3.0 TCP/UDP, Redundant Ethernet interface, 100 Mbit/s, RJ45
- (BASE100-FX)
- X104** – IRIG-B00X, incl. System Contact (Supervision Contact)

# MRMV4-2A0BRB

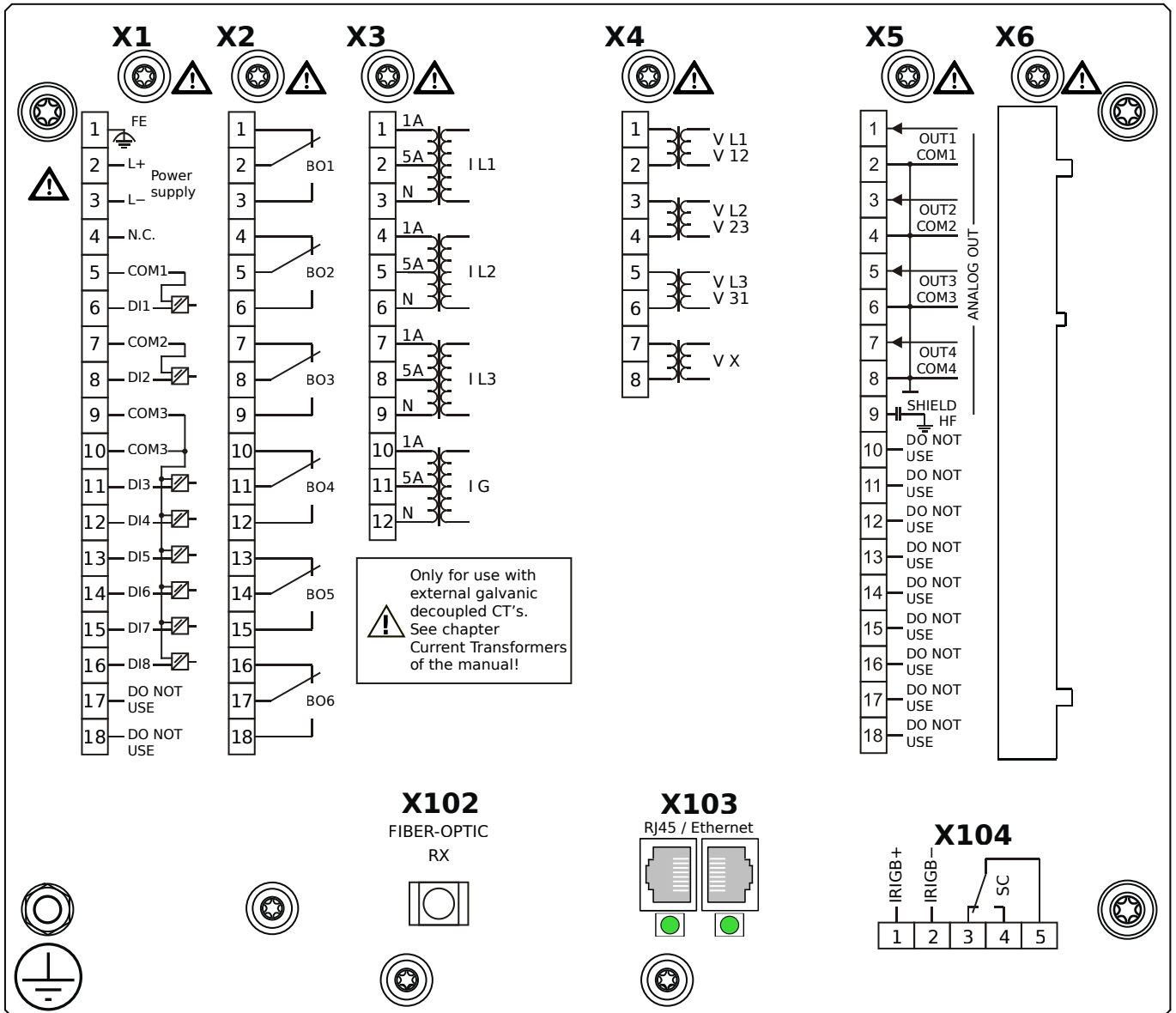

## Housing B2, small display, 19" rack mounting

+ Conformal Coating (for installations in harsh environment)

**X1** – DI8-X1: Wide-range power supply unit, incl. 2 non-grouped digital inputs and 6 grouped digital inputs

**X2** – OR6: Assembly Group with 6 Output Relays (Changeover / Form C)

**X3** – TI: Standard current measuring card

**X4** – TU: Card with 4 voltage transformer measuring inputs (0 ... 800 VAC, under UL: 0 ... 600 VAC)

**X5** – AnO4: Analog Outputs

**X102** – Universal Resistance-Temperature Detector (URTD) input, Fiber optics interface, Versatile Link

**X103** – IEC 61850 / Modbus TCP / IEC 60870-5-104 / DNP3.0 TCP/UDP, Redundant Ethernet interface, 100 Mbit/s, RJ45

(BASE100-FX)

**X104** – IRIG-B00X, incl. System Contact (Supervision Contact)

# MRMV4-2A0BTA

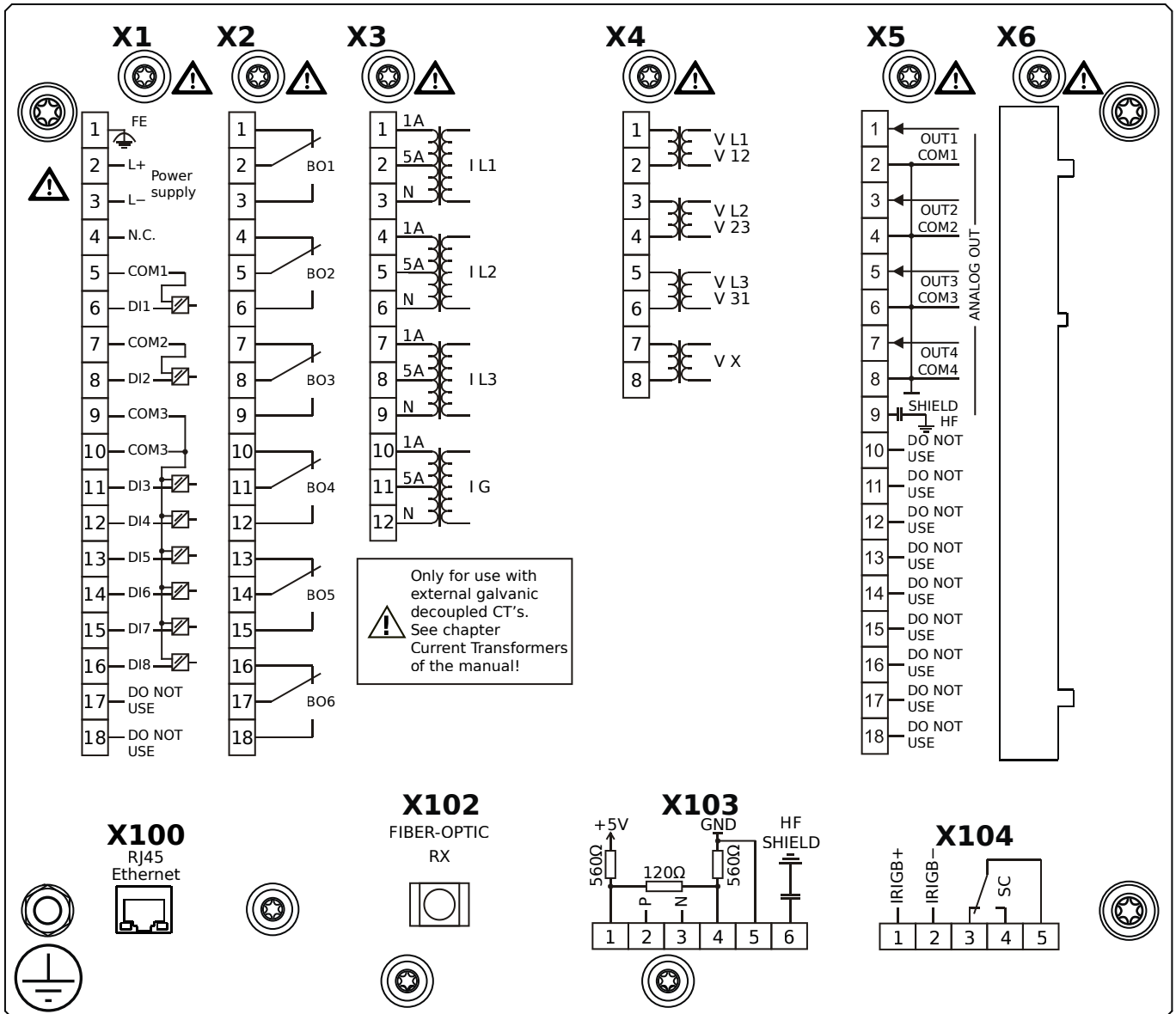

## Housing B2, small display, 19" rack mounting

- X1** – DI8-X1: Wide-range power supply unit, incl. 2 non-grouped digital inputs and 6 grouped digital inputs
- X2** – OR6: Assembly Group with 6 Output Relays (Changeover / Form C)
- X3** – TI: Standard current measuring card
- X4** – TU: Card with 4 voltage transformer measuring inputs (0 ... 800 VAC, under UL: 0 ... 600 VAC)
- X5** – AnO4: Analog Outputs
- X100** – IEC 61850 / Modbus TCP / IEC 60870-5-104 / DNP3.0 TCP/UDP, Ethernet interface, 100 Mbit/s, RJ45 (BASE100-FX)
- X102** – Universal Resistance-Temperature Detector (URTD) input, Fiber optics interface, Versatile Link
- X103** – IEC 60870-5-103 / Modbus RTU / DNP3.0 RTU, RS485, Terminals
- X104** – IRIG-B00X, incl. System Contact (Supervision Contact)



# MRMV4-2A0BTB

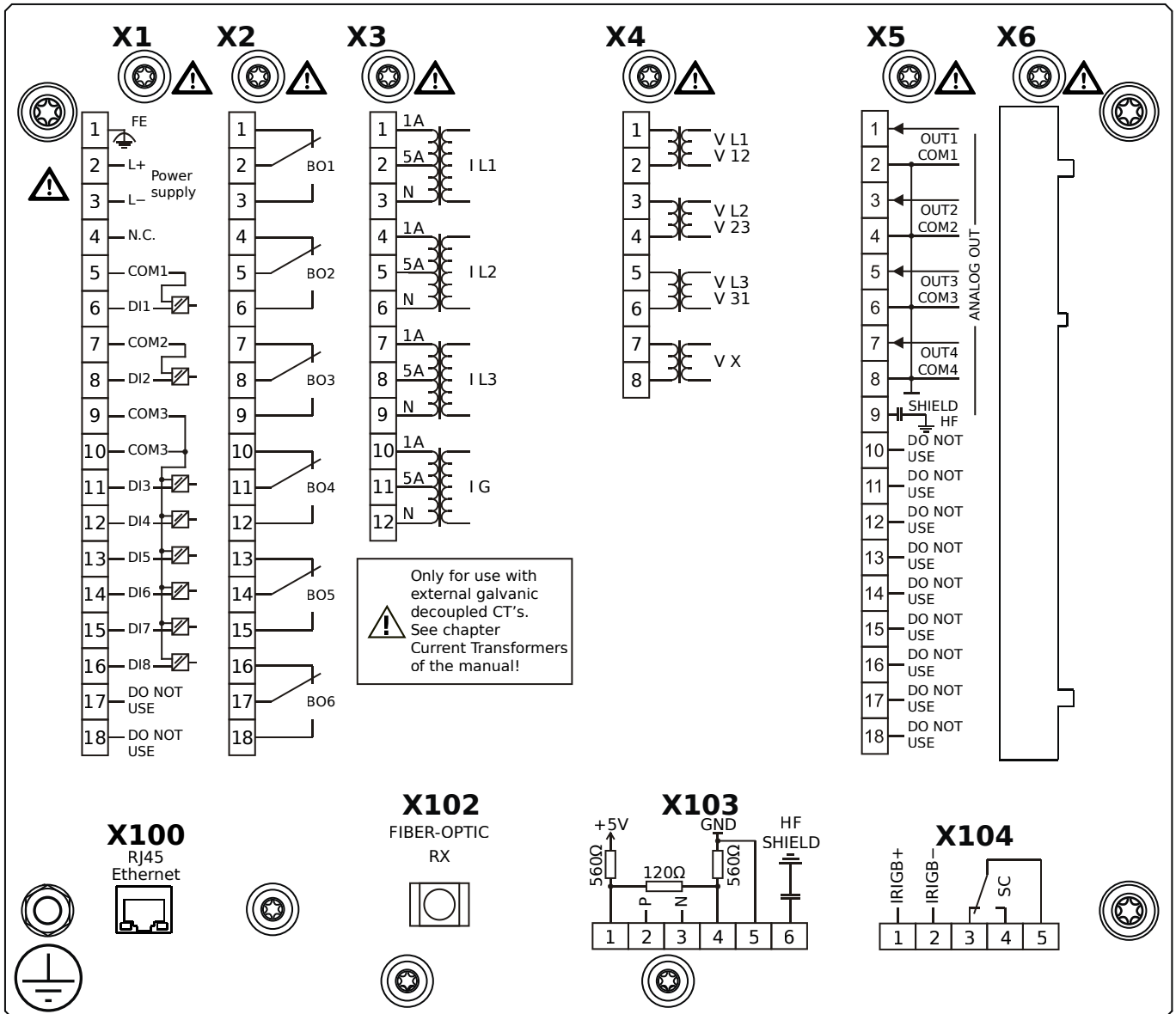

## Housing B2, small display, 19" rack mounting

+ Conformal Coating (for installations in harsh environment)

**X1** – DI8-X1: Wide-range power supply unit, incl. 2 non-grouped digital inputs and 6 grouped digital inputs

**X2** – OR6: Assembly Group with 6 Output Relays (Changeover / Form C)

**X3** – TI: Standard current measuring card

**X4** – TU: Card with 4 voltage transformer measuring inputs (0 ... 800 VAC, under UL: 0 ... 600 VAC)

**X5** – AnO4: Analog Outputs

**X100** – IEC 61850 / Modbus TCP / IEC 60870-5-104 / DNP3.0 TCP/UDP, Ethernet interface, 100 Mbit/s, RJ45 (BASE100-

FX)

**X102** – Universal Resistance-Temperature Detector (URTD) input, Fiber optics interface, Versatile Link

**X103** – IEC 60870-5-103 / Modbus RTU / DNP3.0 RTU, RS485, Terminals

**X104** – IRIG-B00X, incl. System Contact (Supervision Contact)

# MRMV4-2A1AAA

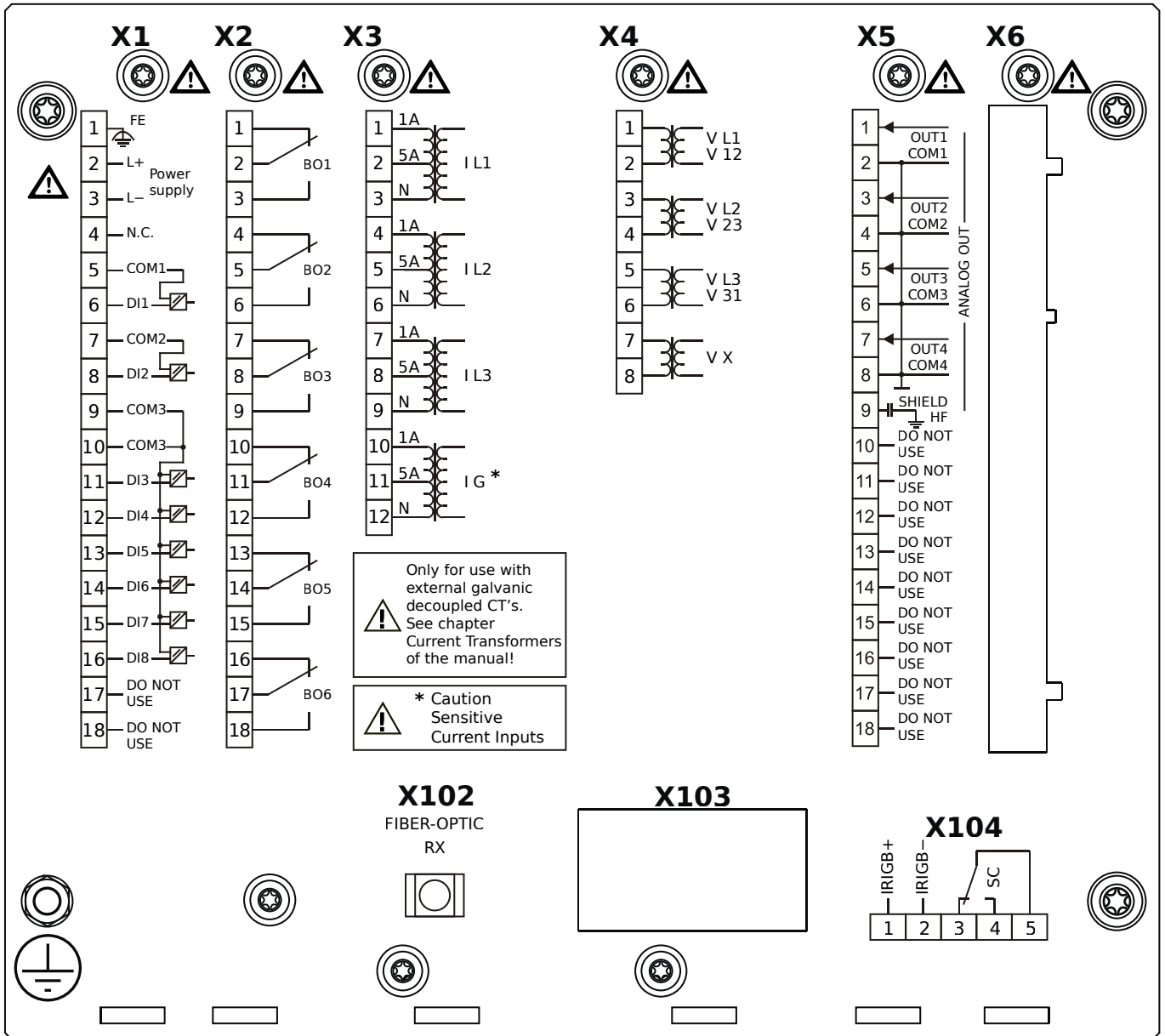

## Housing B2, small display, door mounting

- X1** – DI8-X1: Wide-range power supply unit, incl. 2 non-grouped digital inputs and 6 grouped digital inputs
- X2** – OR6: Assembly Group with 6 Output Relays (Changeover / Form C)
- X3** – TIs: Standard phase current measuring card and sensitive ground current measuring
- X4** – TU: Card with 4 voltage transformer measuring inputs (0 ... 800 VAC, under UL: 0 ... 600 VAC)
- X5** – AnO4: Analog Outputs
- X102** – Universal Resistance-Temperature Detector (URTD) input, Fiber optics interface, Versatile Link
- X104** – IRIG-B00X, incl. System Contact (Supervision Contact)

# MRMV4-2A1AAB

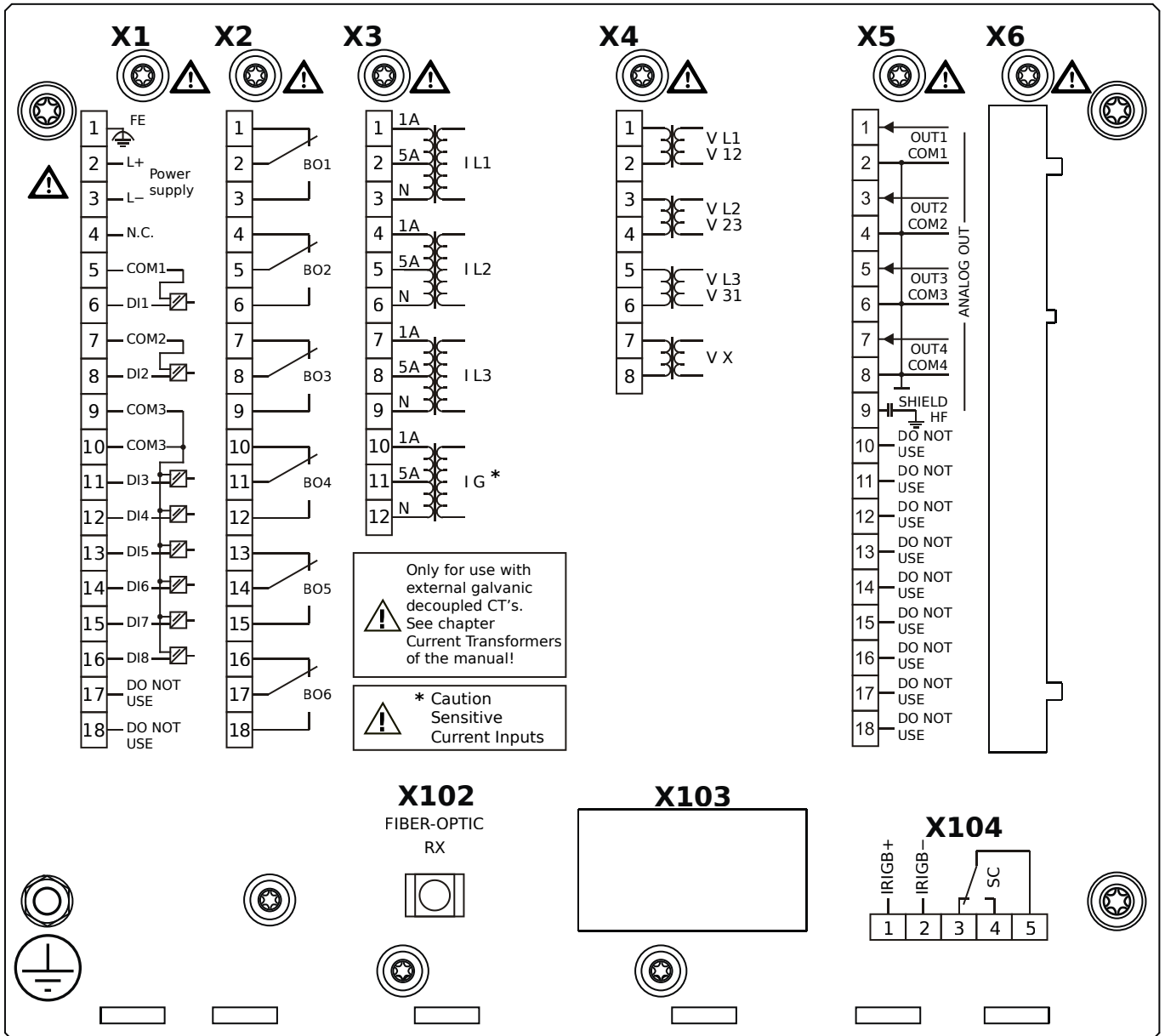

## Housing B2, small display, door mounting

+ Conformal Coating (for installations in harsh environment)

- X1** – DI8-X1: Wide-range power supply unit, incl. 2 non-grouped digital inputs and 6 grouped digital inputs
- X2** – OR6: Assembly Group with 6 Output Relays (Changeover / Form C)
- X3** – TIs: Standard phase current measuring card and sensitive ground current measuring
- X4** – TU: Card with 4 voltage transformer measuring inputs (0 ... 800 VAC, under UL: 0 ... 600 VAC)
- X5** – AnO4: Analog Outputs
- X102** – Universal Resistance-Temperature Detector (URTD) input, Fiber optics interface, Versatile Link
- X104** – IRIG-B00X, incl. System Contact (Supervision Contact)

# MRMV4-2A1ABA

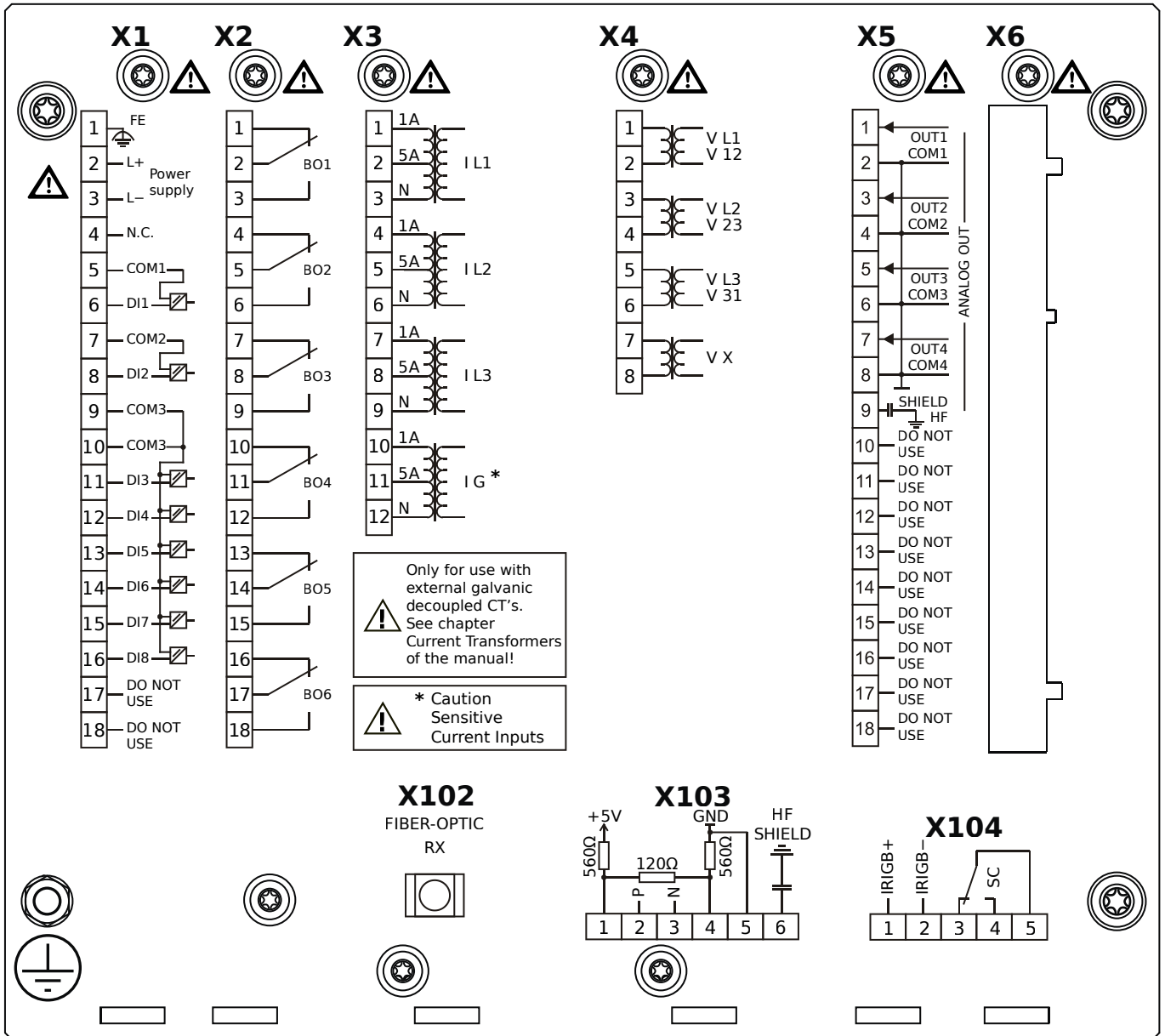

## Housing B2, small display, door mounting

- X1** – DI8-X1: Wide-range power supply unit, incl. 2 non-grouped digital inputs and 6 grouped digital inputs
- X2** – OR6: Assembly Group with 6 Output Relays (Changeover / Form C)
- X3** – TIs: Standard phase current measuring card and sensitive ground current measuring
- X4** – TU: Card with 4 voltage transformer measuring inputs (0 ... 800 VAC, under UL: 0 ... 600 VAC)
- X5** – AnO4: Analog Outputs
- X102** – Universal Resistance-Temperature Detector (URTD) input, Fiber optics interface, Versatile Link
- X103** – Modbus RTU / IEC 60870-5-103 / DNP3.0 RTU, RS485, Terminals
- X104** – IRIG-B00X, incl. System Contact (Supervision Contact)

# MRMV4-2A1ABB

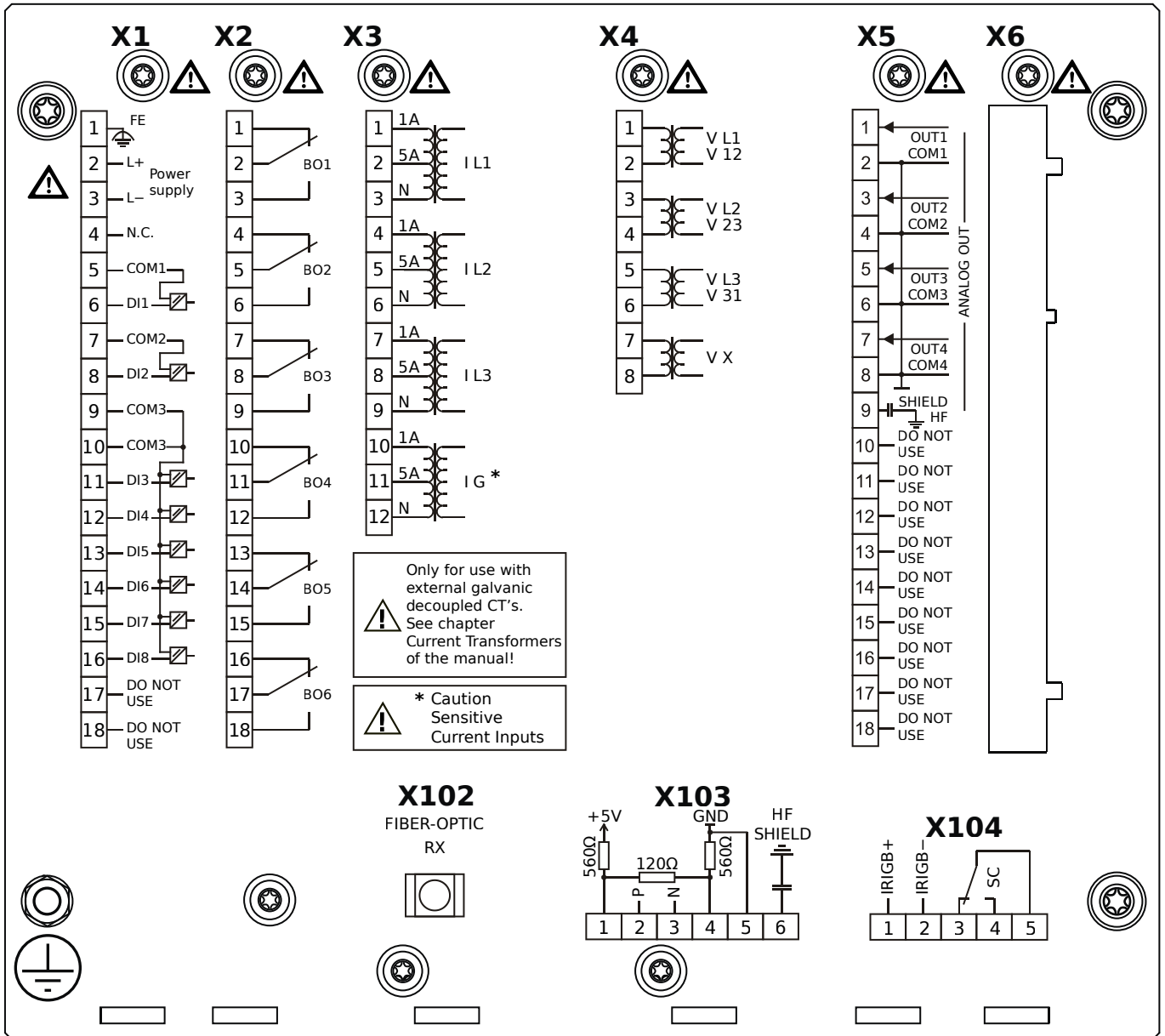

## Housing B2, small display, door mounting

+ Conformal Coating (for installations in harsh environment)

- X1** – DI8-X1: Wide-range power supply unit, incl. 2 non-grouped digital inputs and 6 grouped digital inputs
- X2** – OR6: Assembly Group with 6 Output Relays (Changeover / Form C)
- X3** – TIs: Standard phase current measuring card and sensitive ground current measuring
- X4** – TU: Card with 4 voltage transformer measuring inputs (0 ... 800 VAC, under UL: 0 ... 600 VAC)
- X5** – AnO4: Analog Outputs
- X102** – Universal Resistance-Temperature Detector (URTD) input, Fiber optics interface, Versatile Link
- X103** – Modbus RTU / IEC 60870-5-103 / DNP3.0 RTU, RS485, Terminals
- X104** – IRIG-B00X, incl. System Contact (Supervision Contact)

# MRMV4-2A1ACA

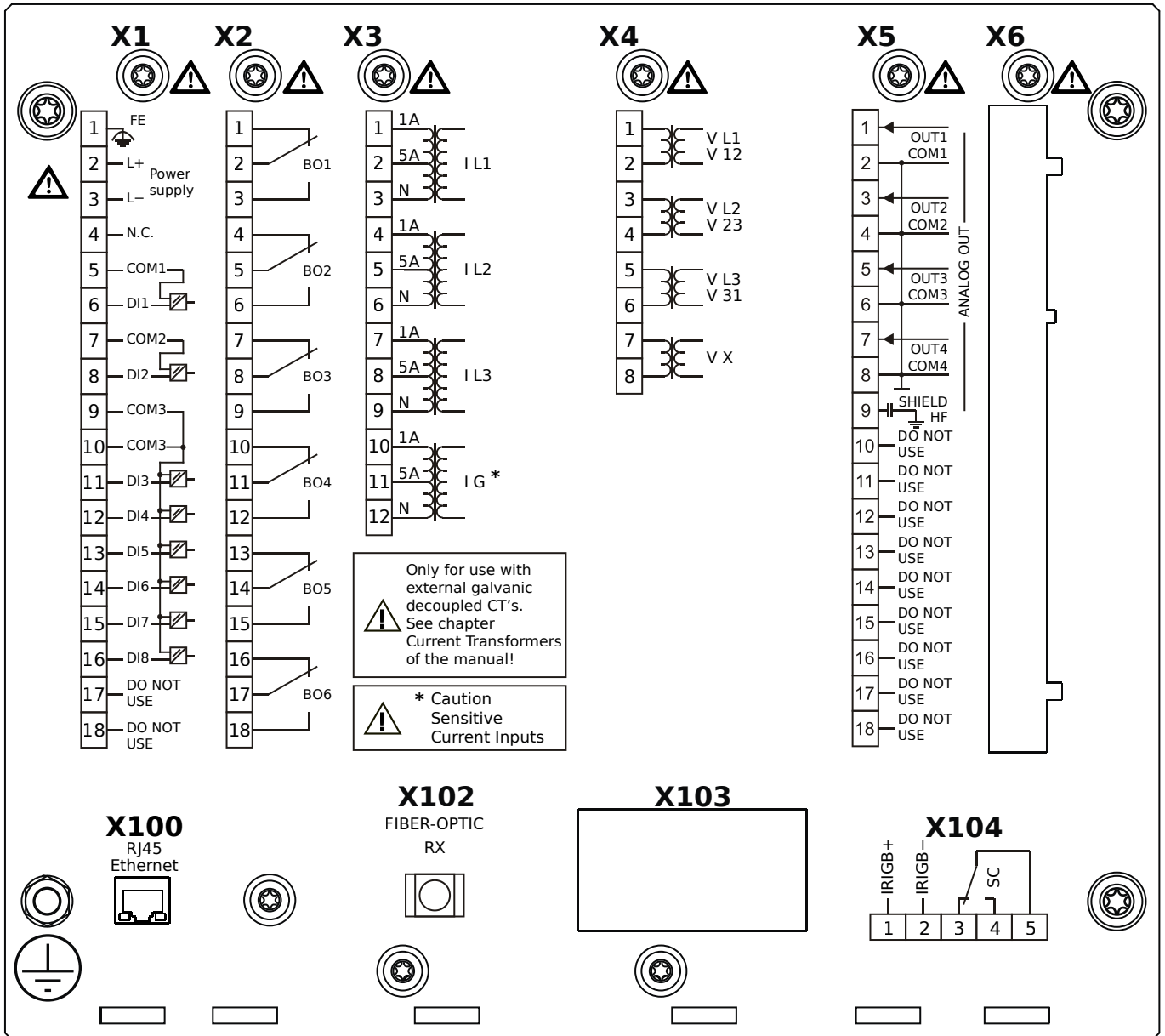

## Housing B2, small display, door mounting

- X1** – DI8-X1: Wide-range power supply unit, incl. 2 non-grouped digital inputs and 6 grouped digital inputs
- X2** – OR6: Assembly Group with 6 Output Relays (Changeover / Form C)
- X3** – TIs: Standard phase current measuring card and sensitive ground current measuring
- X4** – TU: Card with 4 voltage transformer measuring inputs (0 ... 800 VAC, under UL: 0 ... 600 VAC)
- X5** – AnO4: Analog Outputs
- X100** – Modbus TCP / IEC 60870-5-104 / DNP3.0 TCP/UDP, Ethernet interface, 100 Mbit/s, RJ45 (BASE100-FX)
- X102** – Universal Resistance-Temperature Detector (URTD) input, Fiber optics interface, Versatile Link
- X104** – IRIG-B00X, incl. System Contact (Supervision Contact)

# MRMV4-2A1ACB

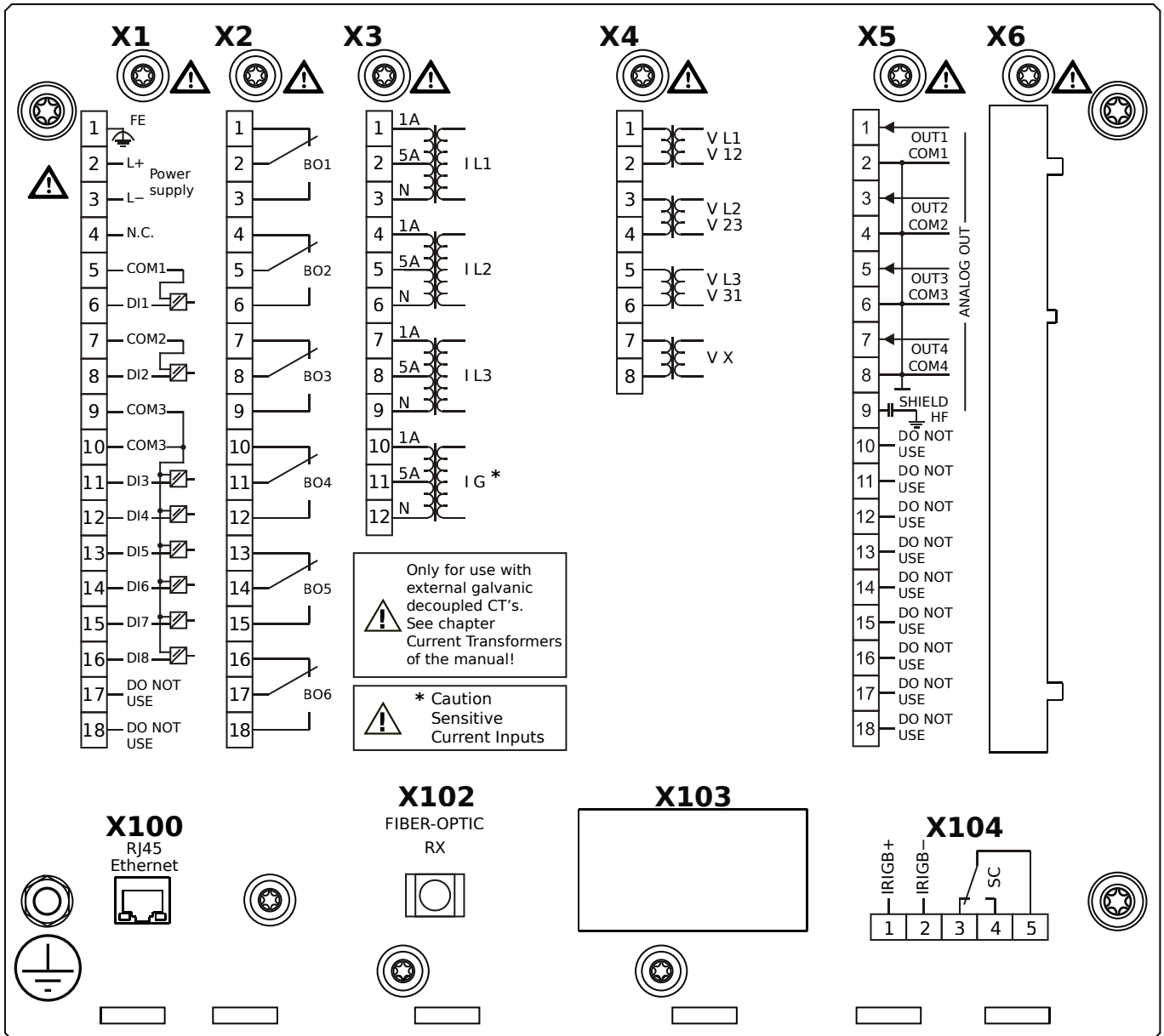

## Housing B2, small display, door mounting

+ Conformal Coating (for installations in harsh environment)

- X1** – DI8-X1: Wide-range power supply unit, incl. 2 non-grouped digital inputs and 6 grouped digital inputs
- X2** – OR6: Assembly Group with 6 Output Relays (Changeover / Form C)
- X3** – TIs: Standard phase current measuring card and sensitive ground current measuring
- X4** – TU: Card with 4 voltage transformer measuring inputs (0 ... 800 VAC, under UL: 0 ... 600 VAC)
- X5** – AnO4: Analog Outputs
- X100** – Modbus TCP / IEC 60870-5-104 / DNP3.0 TCP/UDP, Ethernet interface, 100 Mbit/s, RJ45 (BASE100-FX)
- X102** – Universal Resistance-Temperature Detector (URTD) input, Fiber optics interface, Versatile Link
- X104** – IRIG-B00X, incl. System Contact (Supervision Contact)

# MRMV4-2A1ADA

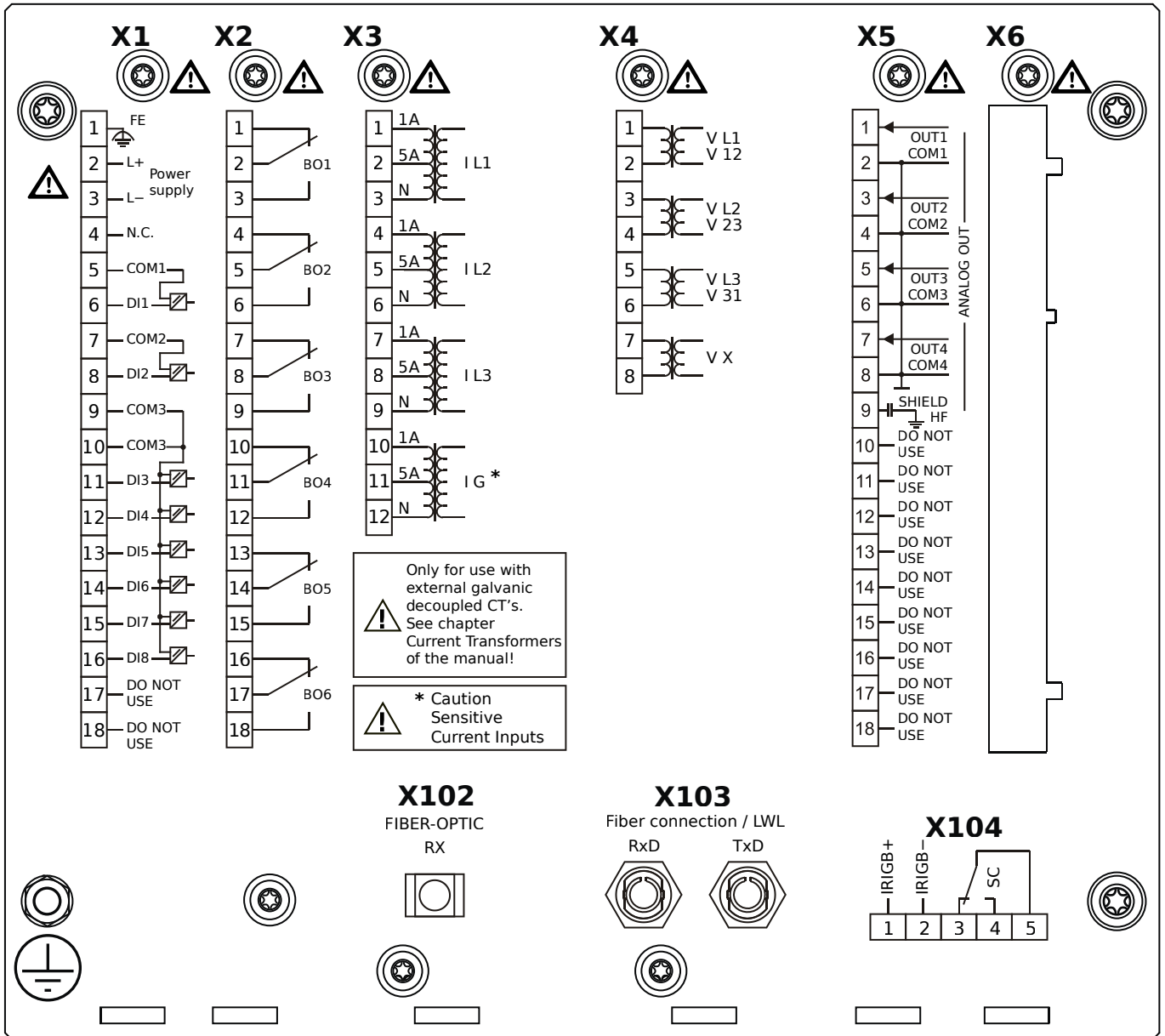

## Housing B2, small display, door mounting

- X1** – DI8-X1: Wide-range power supply unit, incl. 2 non-grouped digital inputs and 6 grouped digital inputs
- X2** – OR6: Assembly Group with 6 Output Relays (Changeover / Form C)
- X3** – TIs: Standard phase current measuring card and sensitive ground current measuring
- X4** – TU: Card with 4 voltage transformer measuring inputs (0 ... 800 VAC, under UL: 0 ... 600 VAC)
- X5** – AnO4: Analog Outputs
- X102** – Universal Resistance-Temperature Detector (URTD) input, Fiber optics interface, Versatile Link
- X103** – Profibus-DP, Fiber optics interface, ST Connector
- X104** – IRIG-B00X, incl. System Contact (Supervision Contact)



# MRMV4-2A1ADB

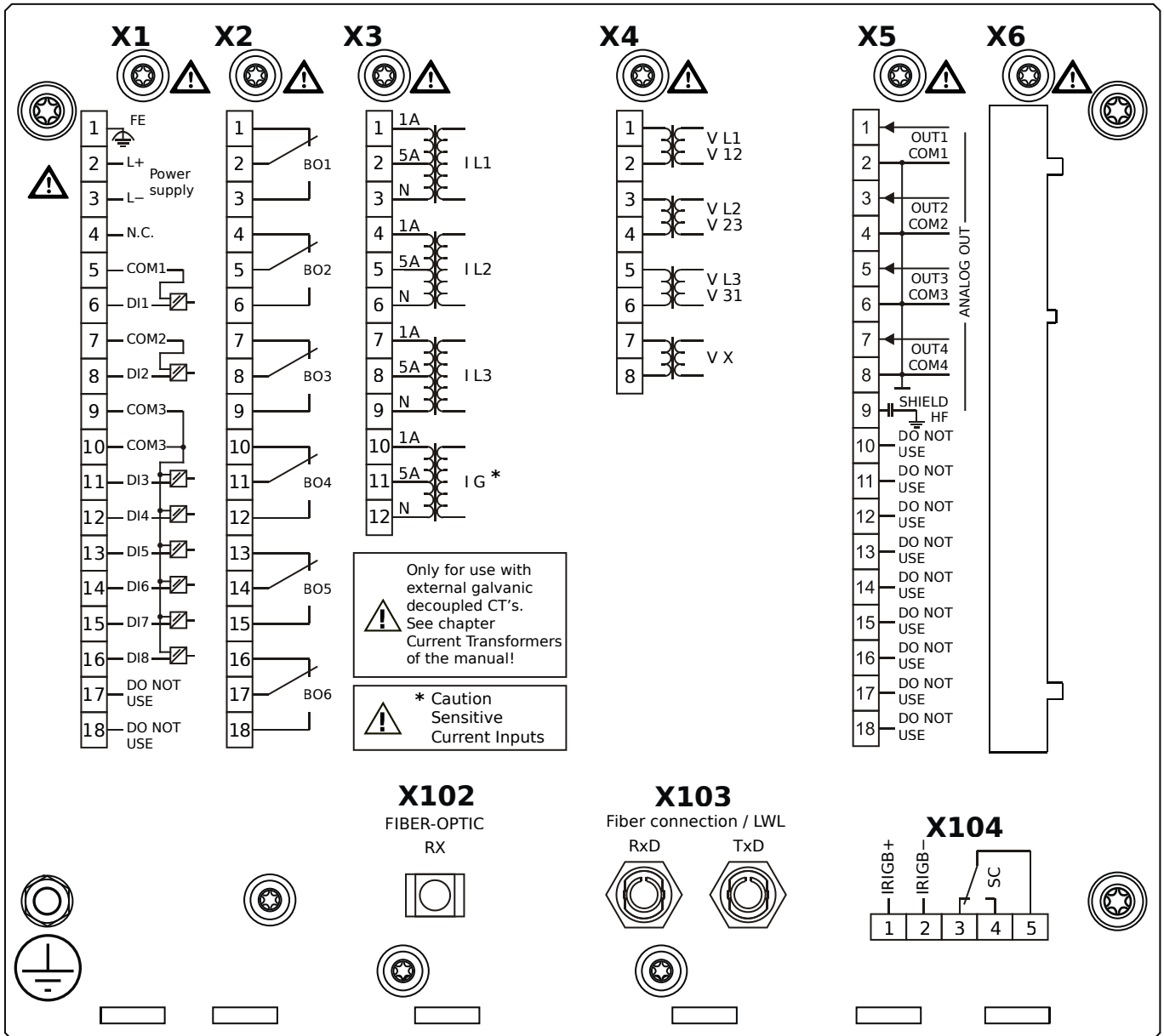

## Housing B2, small display, door mounting

+ Conformal Coating (for installations in harsh environment)

- X1** – DI8-X1: Wide-range power supply unit, incl. 2 non-grouped digital inputs and 6 grouped digital inputs
- X2** – OR6: Assembly Group with 6 Output Relays (Changeover / Form C)
- X3** – TIs: Standard phase current measuring card and sensitive ground current measuring
- X4** – TU: Card with 4 voltage transformer measuring inputs (0 ... 800 VAC, under UL: 0 ... 600 VAC)
- X5** – AnO4: Analog Outputs
- X102** – Universal Resistance-Temperature Detector (URTD) input, Fiber optics interface, Versatile Link
- X103** – Profibus-DP, Fiber optics interface, ST Connector
- X104** – IRIG-B00X, incl. System Contact (Supervision Contact)

# MRMV4-2A1AEA

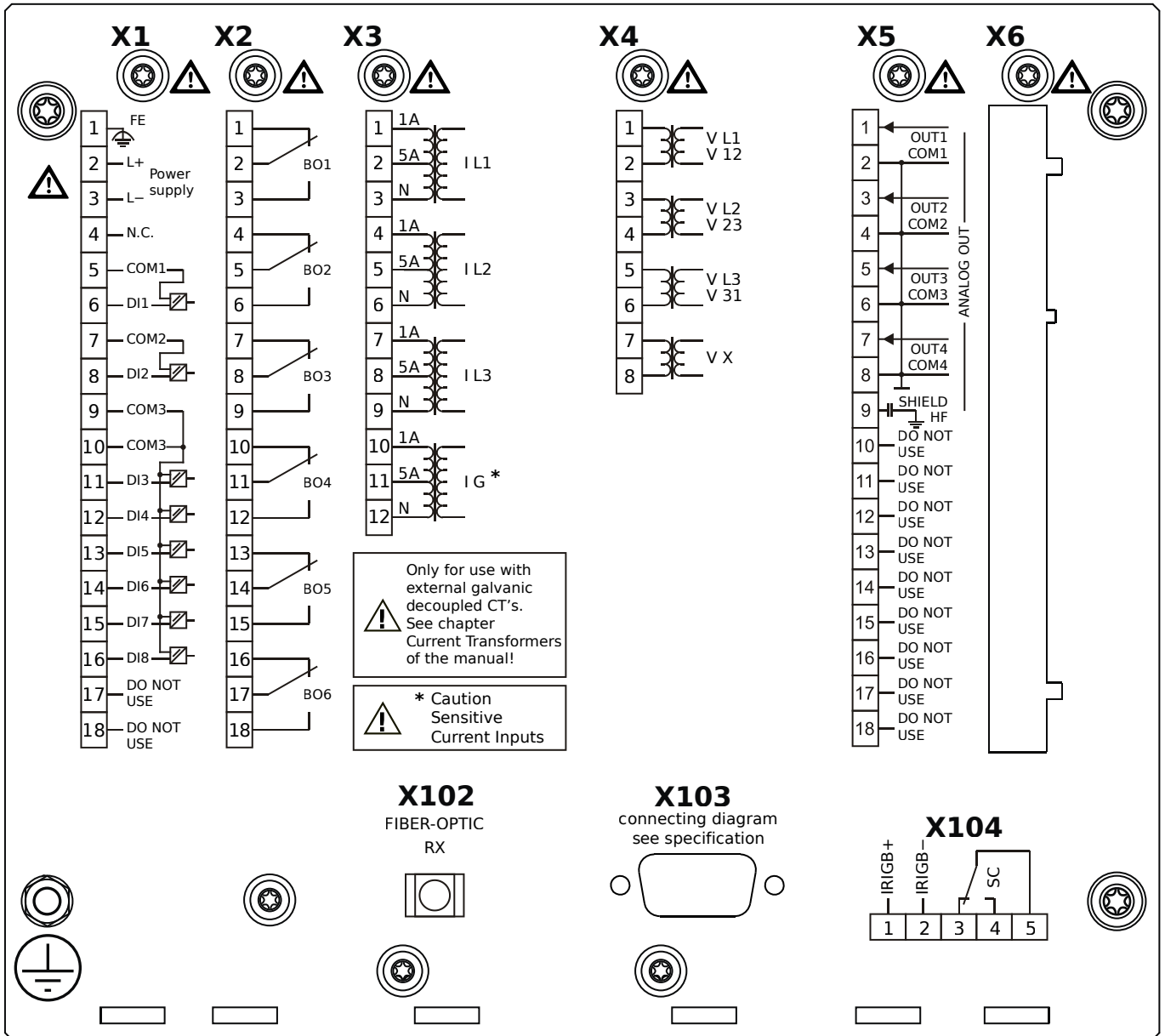

## Housing B2, small display, door mounting

- X1** – DI8-X1: Wide-range power supply unit, incl. 2 non-grouped digital inputs and 6 grouped digital inputs
- X2** – OR6: Assembly Group with 6 Output Relays (Changeover / Form C)
- X3** – TIs: Standard phase current measuring card and sensitive ground current measuring
- X4** – TU: Card with 4 voltage transformer measuring inputs (0 ... 800 VAC, under UL: 0 ... 600 VAC)
- X5** – AnO4: Analog Outputs
- X102** – Universal Resistance-Temperature Detector (URTD) input, Fiber optics interface, Versatile Link
- X103** – Profibus-DP, RS485, D-SUB
- X104** – IRIG-B00X, incl. System Contact (Supervision Contact)

# MRMV4-2A1AEB

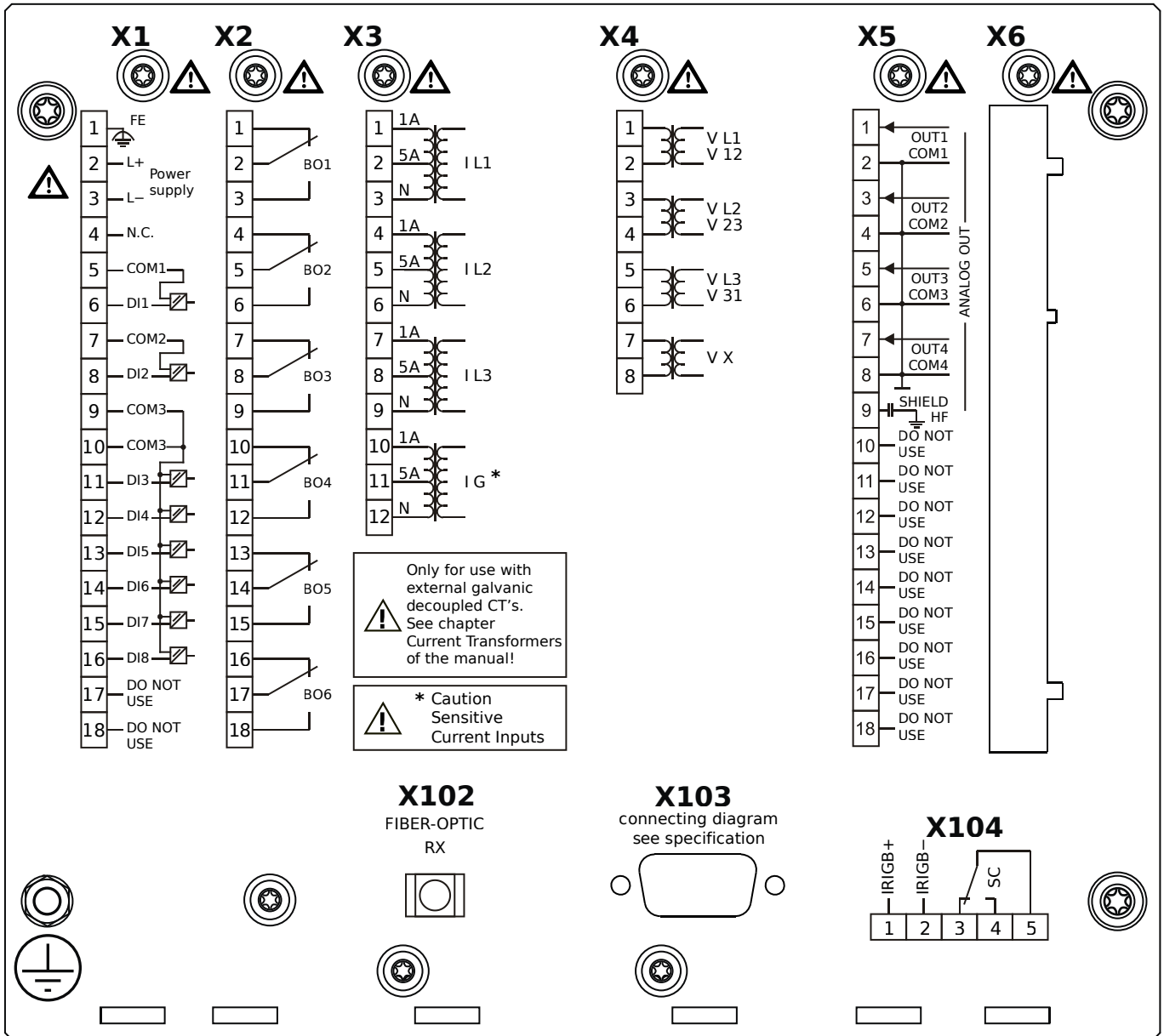

## Housing B2, small display, door mounting

+ Conformal Coating (for installations in harsh environment)

- X1** – DI8-X1: Wide-range power supply unit, incl. 2 non-grouped digital inputs and 6 grouped digital inputs
- X2** – OR6: Assembly Group with 6 Output Relays (Changeover / Form C)
- X3** – TIs: Standard phase current measuring card and sensitive ground current measuring
- X4** – TU: Card with 4 voltage transformer measuring inputs (0 ... 800 VAC, under UL: 0 ... 600 VAC)
- X5** – AnO4: Analog Outputs
- X102** – Universal Resistance-Temperature Detector (URTD) input, Fiber optics interface, Versatile Link
- X103** – Profibus-DP, RS485, D-SUB
- X104** – IRIG-B00X, incl. System Contact (Supervision Contact)

# MRMV4-2A1AFA

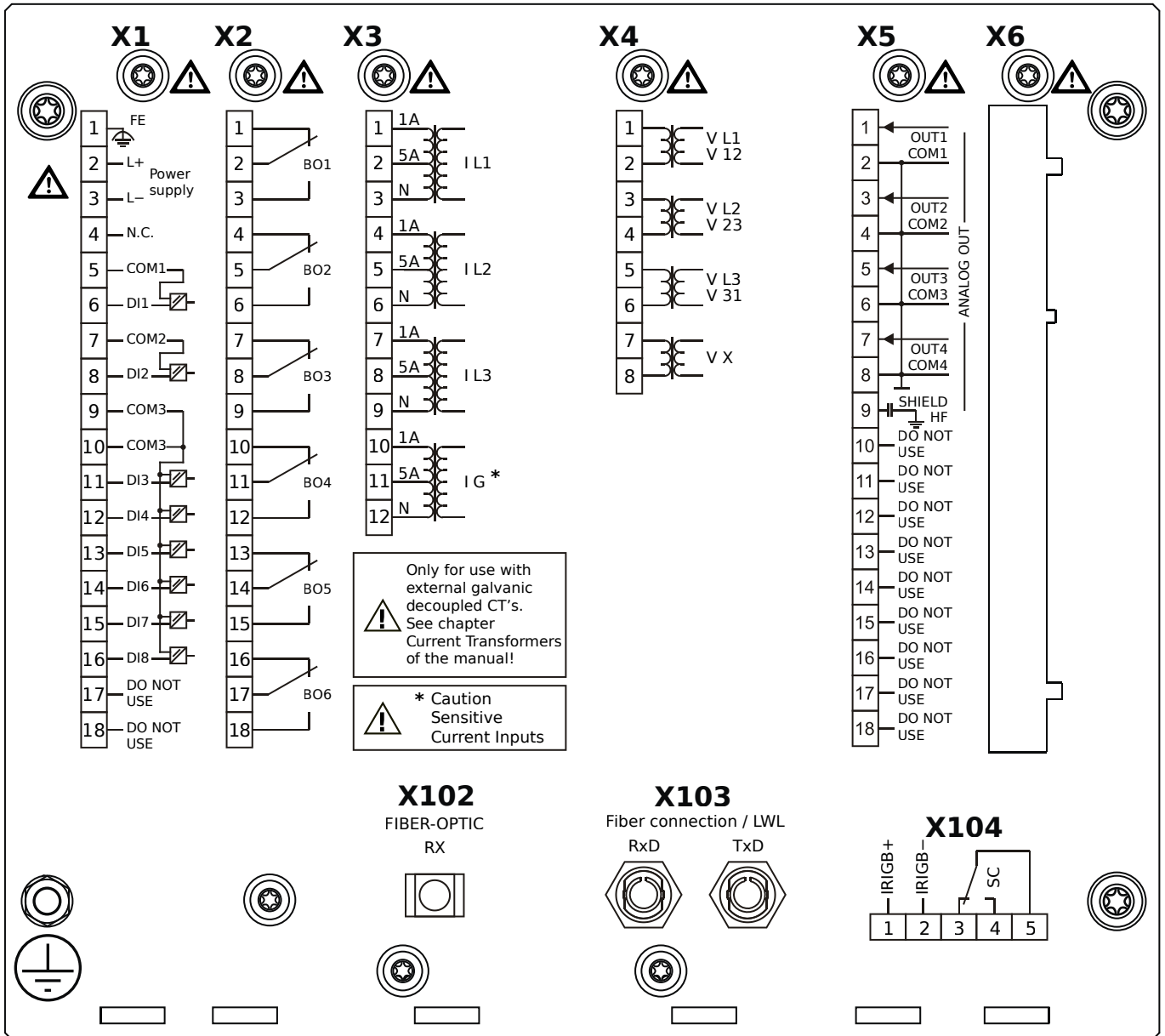

## Housing B2, small display, door mounting

- X1** – DI8-X1: Wide-range power supply unit, incl. 2 non-grouped digital inputs and 6 grouped digital inputs
- X2** – OR6: Assembly Group with 6 Output Relays (Changeover / Form C)
- X3** – TIs: Standard phase current measuring card and sensitive ground current measuring
- X4** – TU: Card with 4 voltage transformer measuring inputs (0 ... 800 VAC, under UL: 0 ... 600 VAC)
- X5** – AnO4: Analog Outputs
- X102** – Universal Resistance-Temperature Detector (URTD) input, Fiber optics interface, Versatile Link
- X103** – Modbus RTU / IEC 60870-5-103 / DNP3.0 RTU, Fiber optics interface, ST Connector
- X104** – IRIG-B00X, incl. System Contact (Supervision Contact)

# MRMV4-2A1AFB

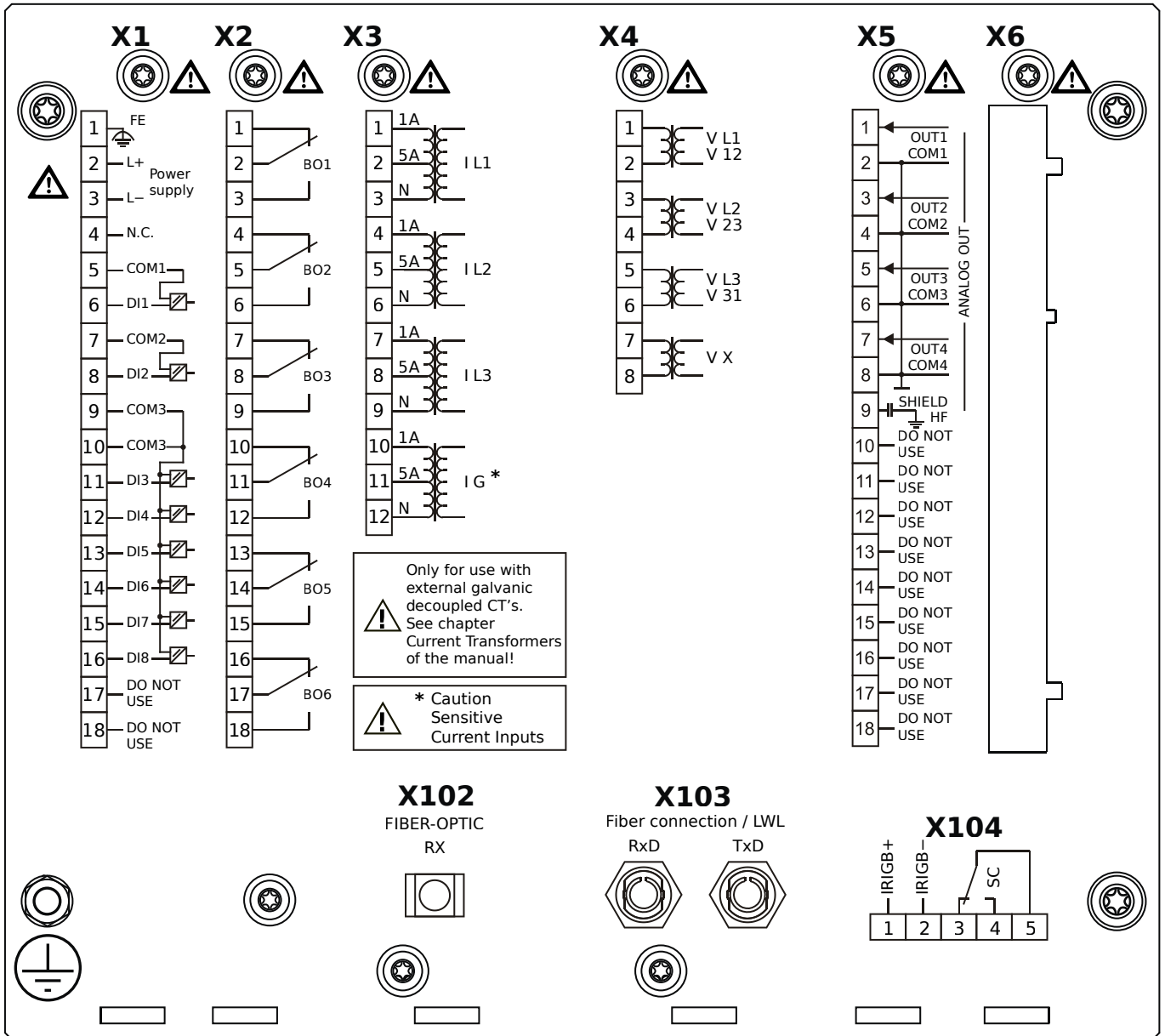

## Housing B2, small display, door mounting

+ Conformal Coating (for installations in harsh environment)

- X1** – DI8-X1: Wide-range power supply unit, incl. 2 non-grouped digital inputs and 6 grouped digital inputs
- X2** – OR6: Assembly Group with 6 Output Relays (Changeover / Form C)
- X3** – TIs: Standard phase current measuring card and sensitive ground current measuring
- X4** – TU: Card with 4 voltage transformer measuring inputs (0 ... 800 VAC, under UL: 0 ... 600 VAC)
- X5** – AnO4: Analog Outputs
- X102** – Universal Resistance-Temperature Detector (URTD) input, Fiber optics interface, Versatile Link
- X103** – Modbus RTU / IEC 60870-5-103 / DNP3.0 RTU, Fiber optics interface, ST Connector
- X104** – IRIG-B00X, incl. System Contact (Supervision Contact)

# MRMV4-2A1AGA

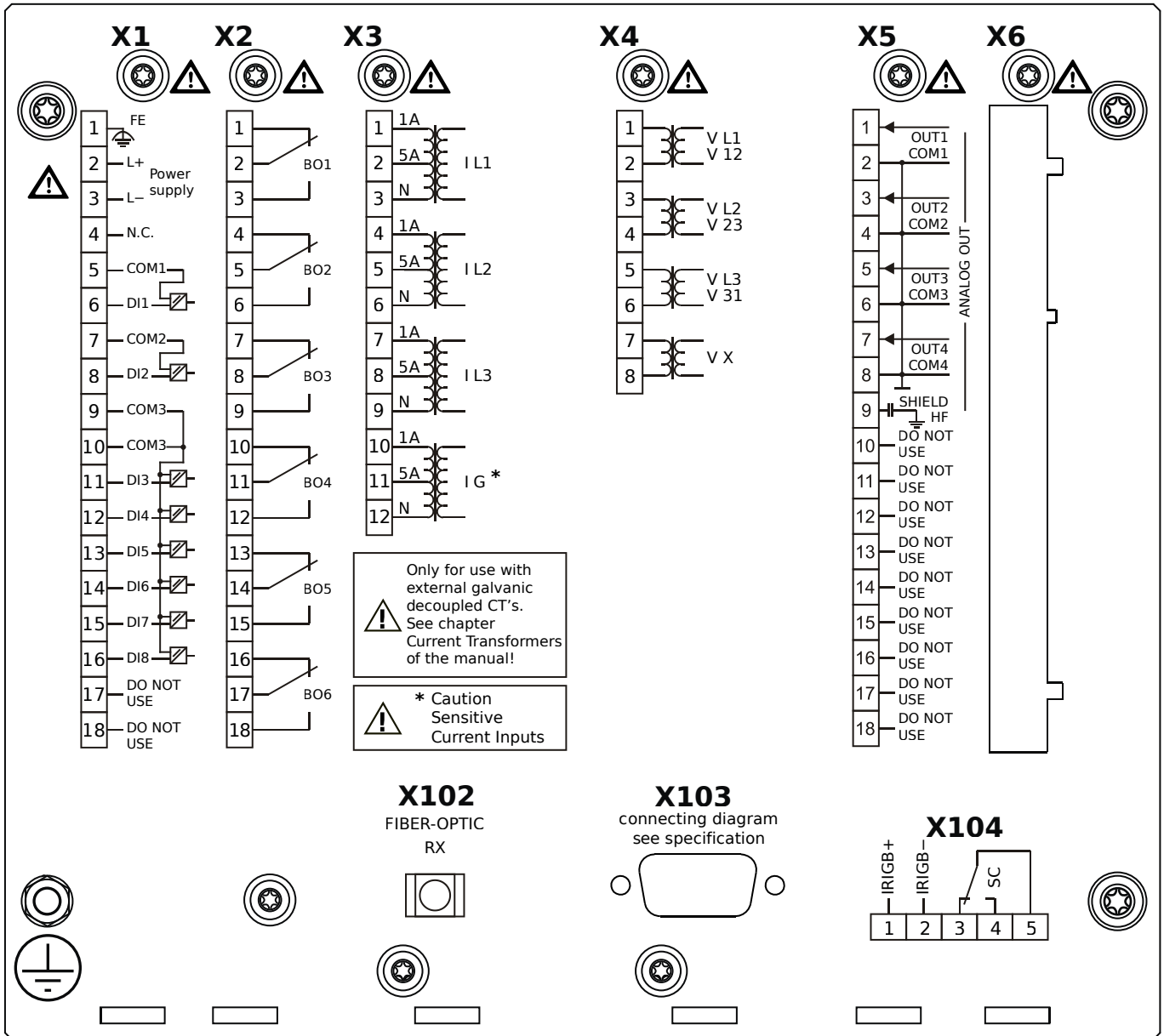

## Housing B2, small display, door mounting

- X1** – DI8-X1: Wide-range power supply unit, incl. 2 non-grouped digital inputs and 6 grouped digital inputs
- X2** – OR6: Assembly Group with 6 Output Relays (Changeover / Form C)
- X3** – TIs: Standard phase current measuring card and sensitive ground current measuring
- X4** – TU: Card with 4 voltage transformer measuring inputs (0 ... 800 VAC, under UL: 0 ... 600 VAC)
- X5** – AnO4: Analog Outputs
- X102** – Universal Resistance-Temperature Detector (URTD) input, Fiber optics interface, Versatile Link
- X103** – Modbus RTU / IEC 60870-5-103 / DNP3.0 RTU, RS485, D-SUB
- X104** – IRIG-B00X, incl. System Contact (Supervision Contact)

# MRMV4-2A1AGB

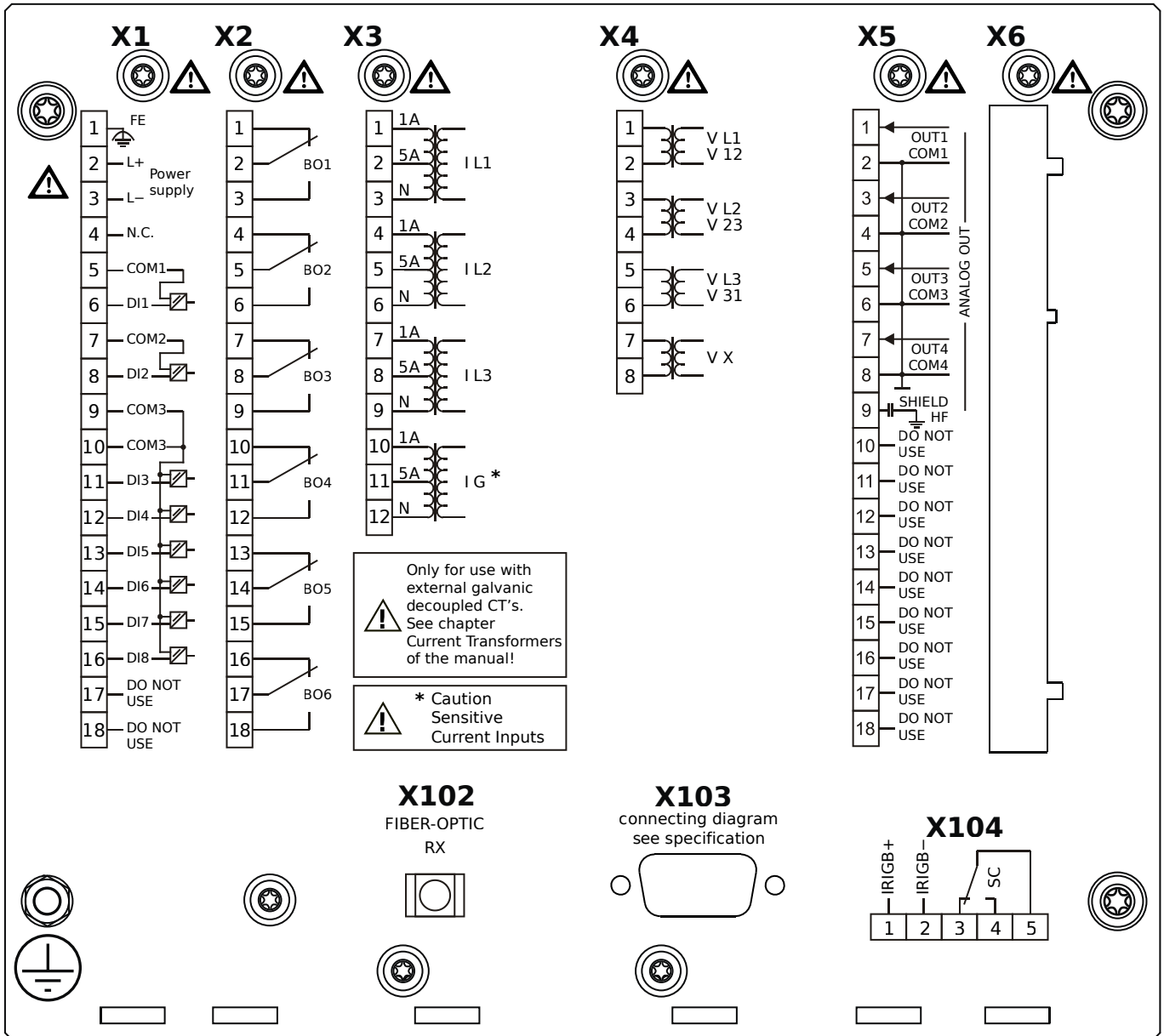

## Housing B2, small display, door mounting

+ Conformal Coating (for installations in harsh environment)

- X1** – DI8-X1: Wide-range power supply unit, incl. 2 non-grouped digital inputs and 6 grouped digital inputs
- X2** – OR6: Assembly Group with 6 Output Relays (Changeover / Form C)
- X3** – TIs: Standard phase current measuring card and sensitive ground current measuring
- X4** – TU: Card with 4 voltage transformer measuring inputs (0 ... 800 VAC, under UL: 0 ... 600 VAC)
- X5** – AnO4: Analog Outputs
- X102** – Universal Resistance-Temperature Detector (URTD) input, Fiber optics interface, Versatile Link
- X103** – Modbus RTU / IEC 60870-5-103 / DNP3.0 RTU, RS485, D-SUB
- X104** – IRIG-B00X, incl. System Contact (Supervision Contact)

# MRMV4-2A1AHA

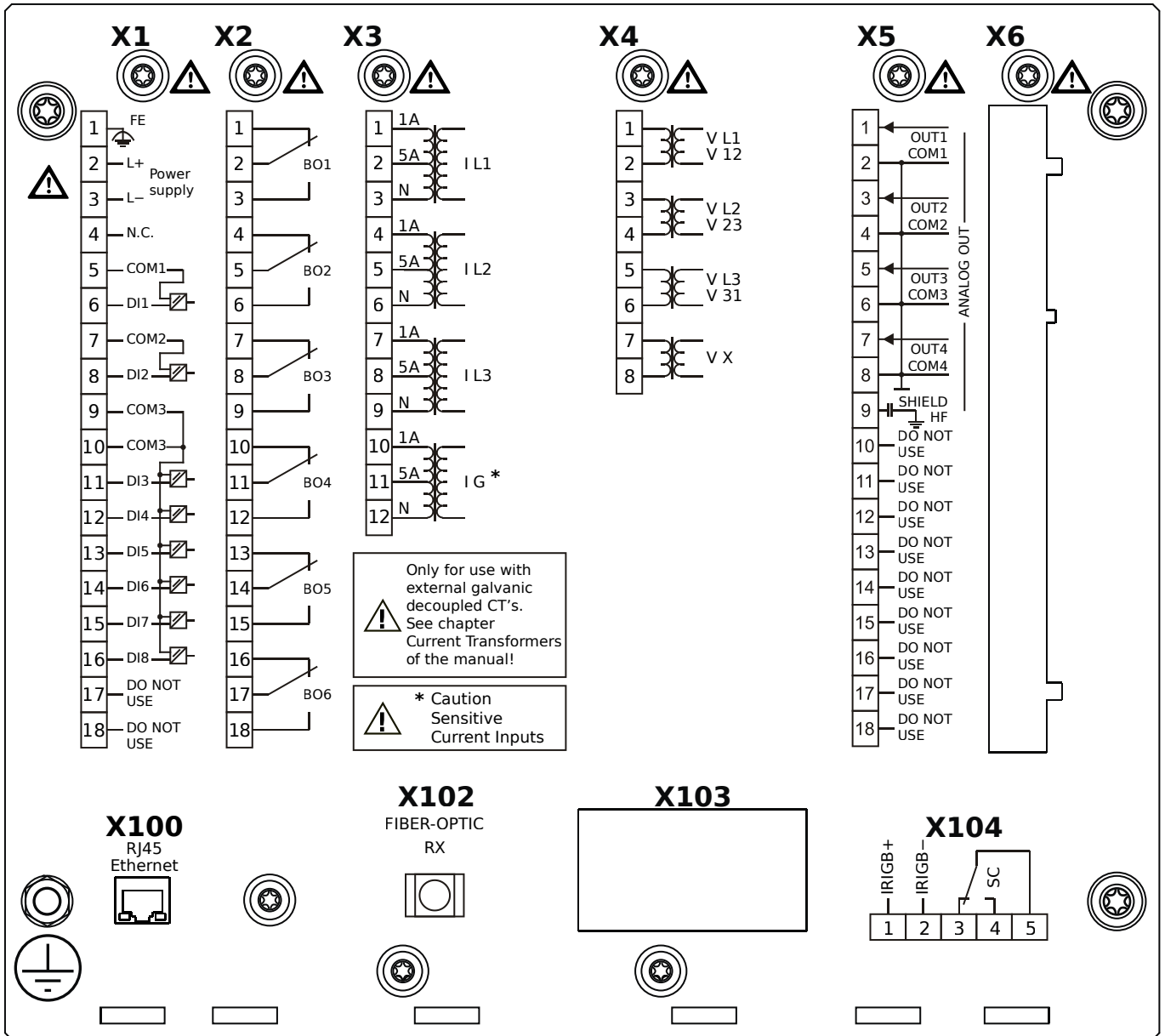

## Housing B2, small display, door mounting

- X1** – DI8-X1: Wide-range power supply unit, incl. 2 non-grouped digital inputs and 6 grouped digital inputs
- X2** – OR6: Assembly Group with 6 Output Relays (Changeover / Form C)
- X3** – TIs: Standard phase current measuring card and sensitive ground current measuring
- X4** – TU: Card with 4 voltage transformer measuring inputs (0 ... 800 VAC, under UL: 0 ... 600 VAC)
- X5** – AnO4: Analog Outputs
- X100** – IEC 61850 / Modbus TCP / IEC 60870-5-104 / DNP3.0 TCP/UDP, Ethernet interface, 100 Mbit/s, RJ45 (BASE100-
- X102** – Universal Resistance-Temperature Detector (URTD) input, Fiber optics interface, Versatile Link
- X104** – IRIG-B00X, incl. System Contact (Supervision Contact)

FX)



# MRMV4-2A1AHB

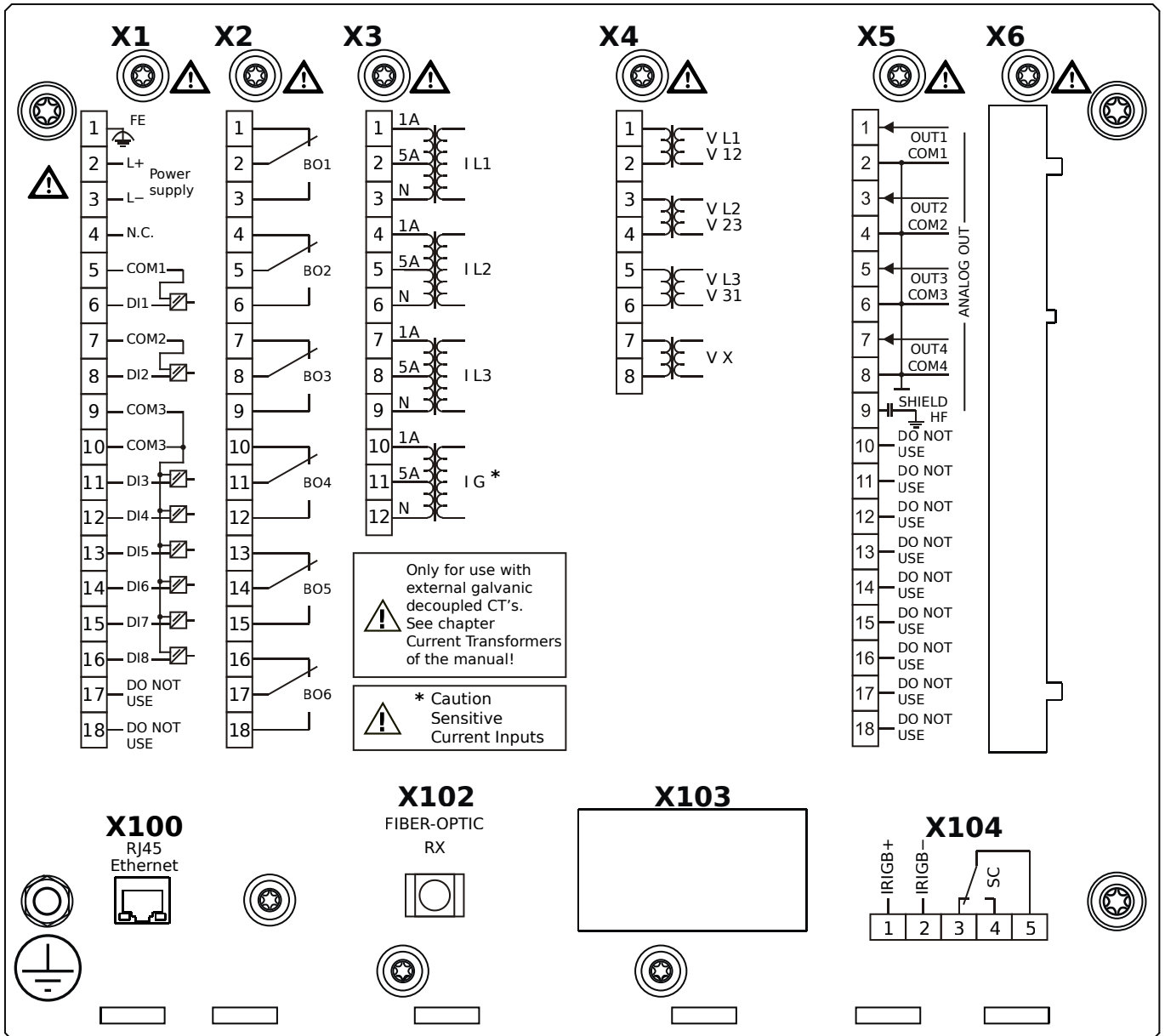

## Housing B2, small display, door mounting

+ Conformal Coating (for installations in harsh environment)

**X1** – DI8-X1: Wide-range power supply unit, incl. 2 non-grouped digital inputs and 6 grouped digital inputs

**X2** – OR6: Assembly Group with 6 Output Relays (Changeover / Form C)

**X3** – TIs: Standard phase current measuring card and sensitive ground current measuring

**X4** – TU: Card with 4 voltage transformer measuring inputs (0 ... 800 VAC, under UL: 0 ... 600 VAC)

**X5** – AnO4: Analog Outputs

**X100** – IEC 61850 / Modbus TCP / IEC 60870-5-104 / DNP3.0 TCP/UDP, Ethernet interface, 100 Mbit/s, RJ45 (BASE100-

FX)

**X102** – Universal Resistance-Temperature Detector (URTD) input, Fiber optics interface, Versatile Link

**X104** – IRIG-B00X, incl. System Contact (Supervision Contact)

# MRMV4-2A1AIA

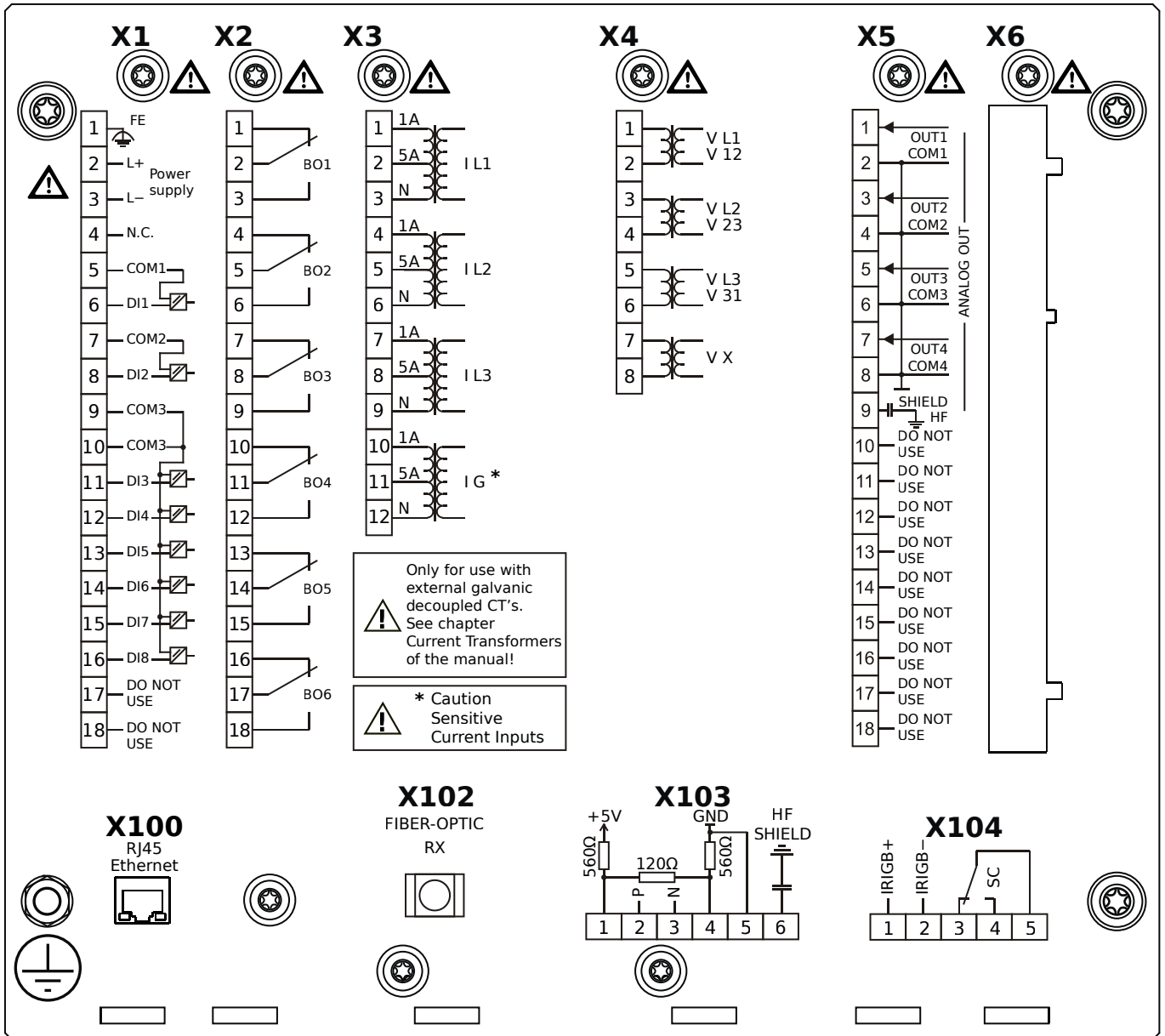

## Housing B2, small display, door mounting

- X1** – DI8-X1: Wide-range power supply unit, incl. 2 non-grouped digital inputs and 6 grouped digital inputs
- X2** – OR6: Assembly Group with 6 Output Relays (Changeover / Form C)
- X3** – TIs: Standard phase current measuring card and sensitive ground current measuring
- X4** – TU: Card with 4 voltage transformer measuring inputs (0 ... 800 VAC, under UL: 0 ... 600 VAC)
- X5** – AnO4: Analog Outputs
- X100** – Modbus TCP / IEC 60870-5-104 / DNP3.0 TCP/UDP, Ethernet interface, 100 Mbit/s, RJ45 (BASE100-FX)
- X102** – Universal Resistance-Temperature Detector (URTD) input, Fiber optics interface, Versatile Link
- X103** – IEC 60870-5-103 / Modbus RTU / DNP3.0 RTU, RS485, Terminals
- X104** – IRIG-B00X, incl. System Contact (Supervision Contact)

# MRMV4-2A1AIB

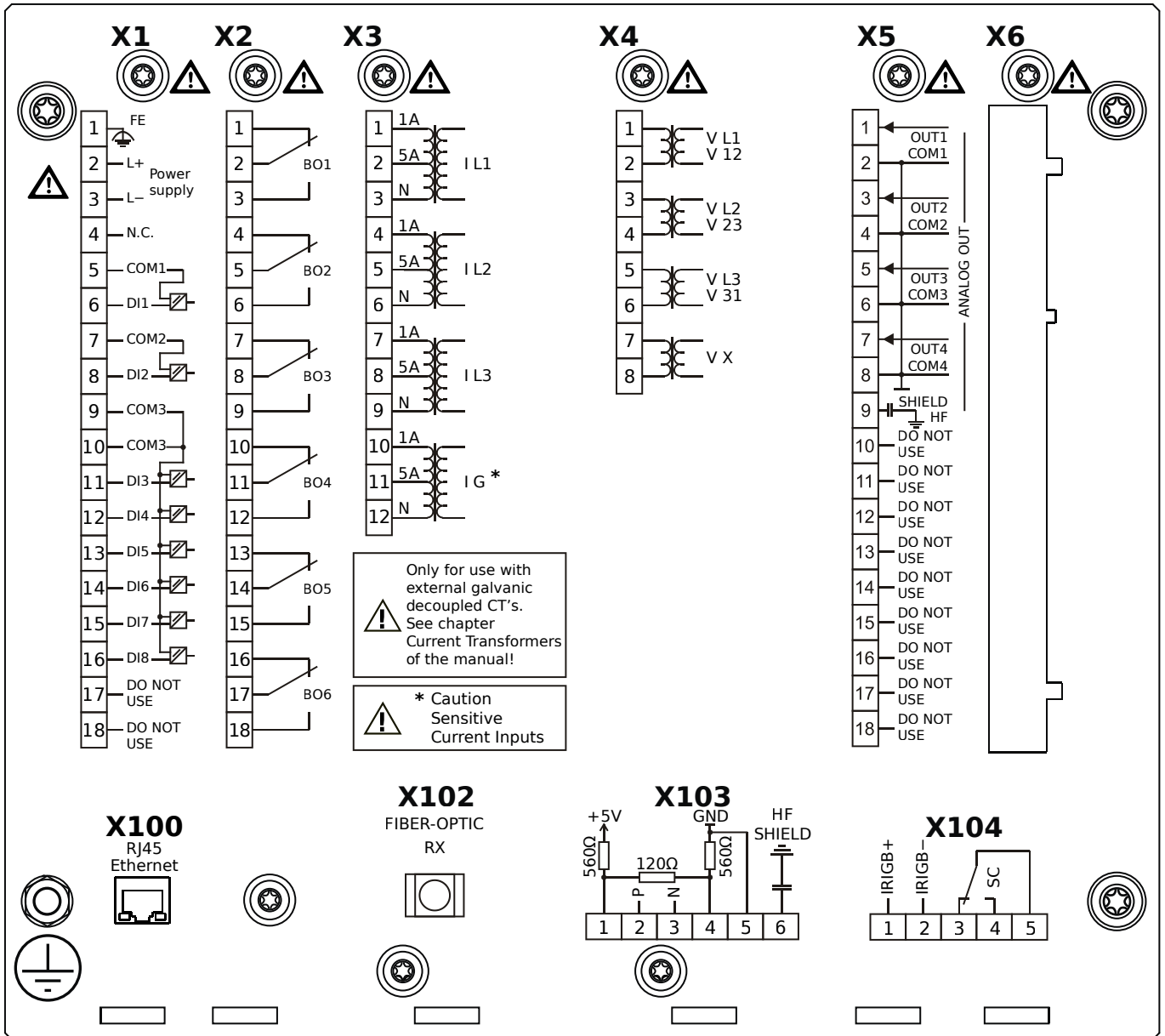

## Housing B2, small display, door mounting

+ Conformal Coating (for installations in harsh environment)

- X1** – DI8-X1: Wide-range power supply unit, incl. 2 non-grouped digital inputs and 6 grouped digital inputs
- X2** – OR6: Assembly Group with 6 Output Relays (Changeover / Form C)
- X3** – TIs: Standard phase current measuring card and sensitive ground current measuring
- X4** – TU: Card with 4 voltage transformer measuring inputs (0 ... 800 VAC, under UL: 0 ... 600 VAC)
- X5** – AnO4: Analog Outputs
- X100** – Modbus TCP / IEC 60870-5-104 / DNP3.0 TCP/UDP, Ethernet interface, 100 Mbit/s, RJ45 (BASE100-FX)
- X102** – Universal Resistance-Temperature Detector (URTD) input, Fiber optics interface, Versatile Link
- X103** – IEC 60870-5-103 / Modbus RTU / DNP3.0 RTU, RS485, Terminals
- X104** – IRIG-B00X, incl. System Contact (Supervision Contact)

# MRMV4-2A1AKA

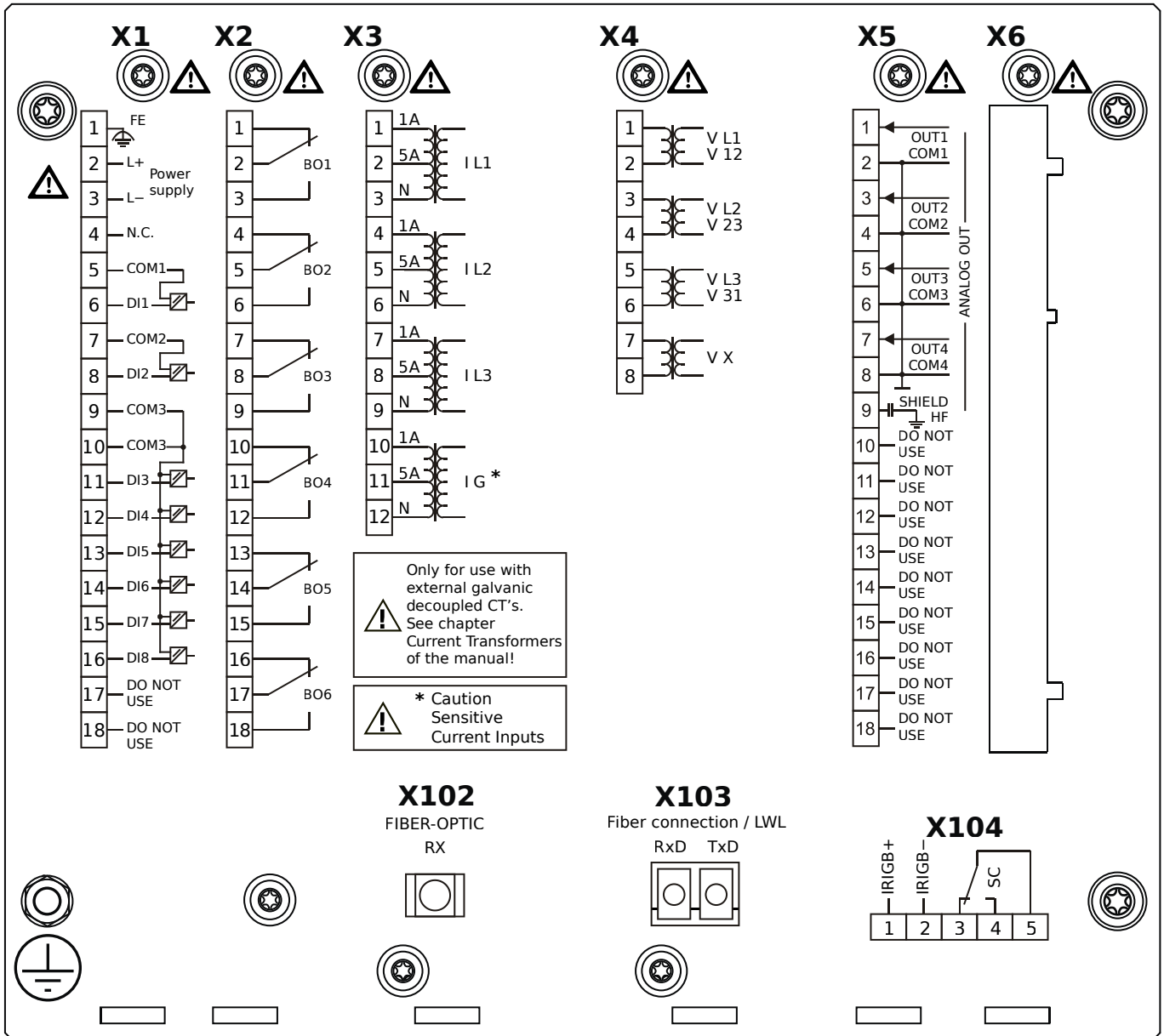

## Housing B2, small display, door mounting

- X1** – DI8-X1: Wide-range power supply unit, incl. 2 non-grouped digital inputs and 6 grouped digital inputs
- X2** – OR6: Assembly Group with 6 Output Relays (Changeover / Form C)
- X3** – TIs: Standard phase current measuring card and sensitive ground current measuring
- X4** – TU: Card with 4 voltage transformer measuring inputs (0 ... 800 VAC, under UL: 0 ... 600 VAC)
- X5** – AnO4: Analog Outputs
- X102** – Universal Resistance-Temperature Detector (URTD) input, Fiber optics interface, Versatile Link
- X103** – IEC 61850 / Modbus TCP / IEC 60870-5-104 / DNP3.0 TCP/UDP, Fiber optics interface, LC Connector
- X104** – IRIG-B00X, incl. System Contact (Supervision Contact)

# MRMV4-2A1AKB

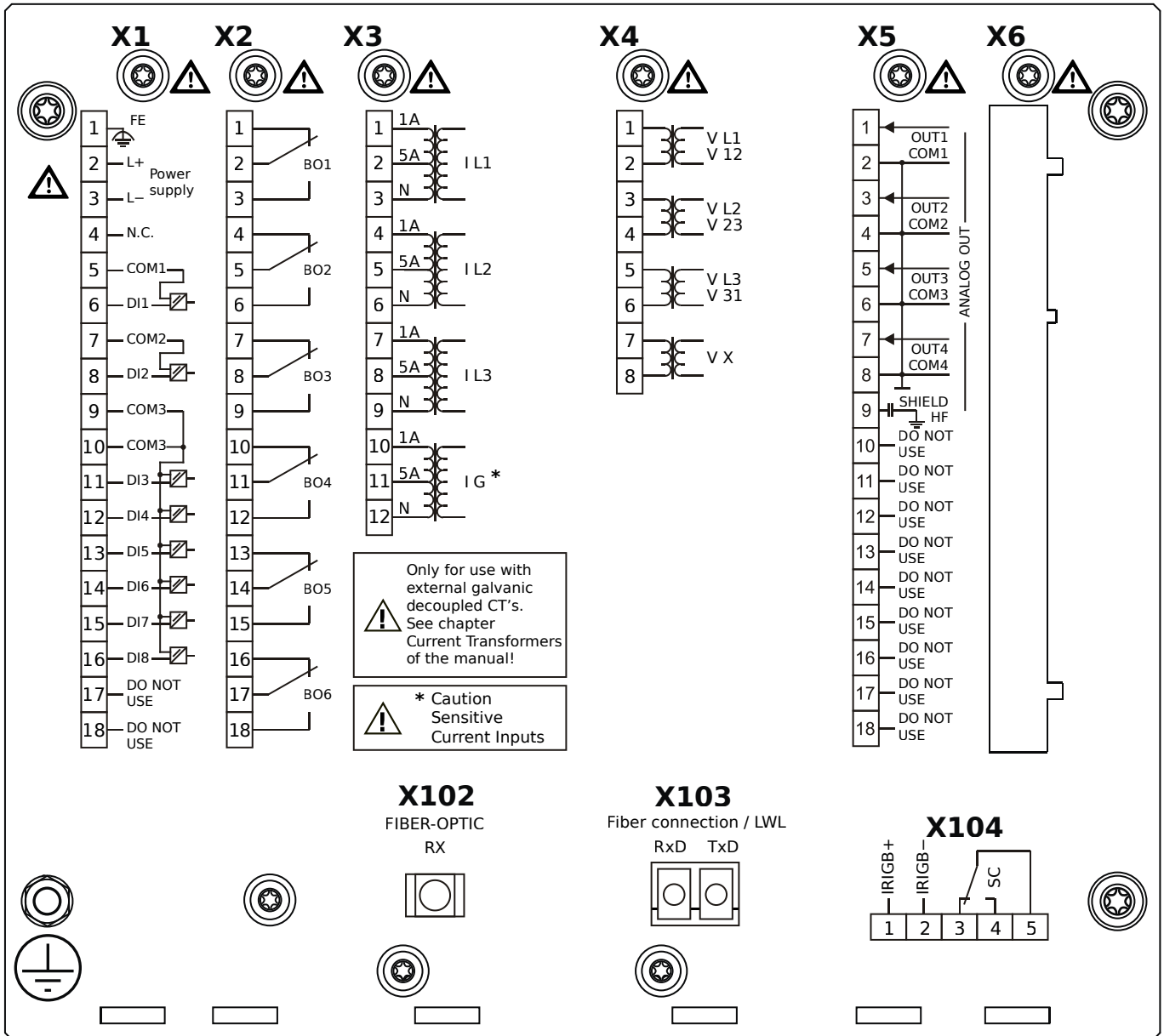

## Housing B2, small display, door mounting

+ Conformal Coating (for installations in harsh environment)

- X1** – DI8-X1: Wide-range power supply unit, incl. 2 non-grouped digital inputs and 6 grouped digital inputs
- X2** – OR6: Assembly Group with 6 Output Relays (Changeover / Form C)
- X3** – TIs: Standard phase current measuring card and sensitive ground current measuring
- X4** – TU: Card with 4 voltage transformer measuring inputs (0 ... 800 VAC, under UL: 0 ... 600 VAC)
- X5** – AnO4: Analog Outputs
- X102** – Universal Resistance-Temperature Detector (URTD) input, Fiber optics interface, Versatile Link
- X103** – IEC 61850 / Modbus TCP / IEC 60870-5-104 / DNP3.0 TCP/UDP, Fiber optics interface, LC Connector
- X104** – IRIG-B00X, incl. System Contact (Supervision Contact)

# MRMV4-2A1ALA

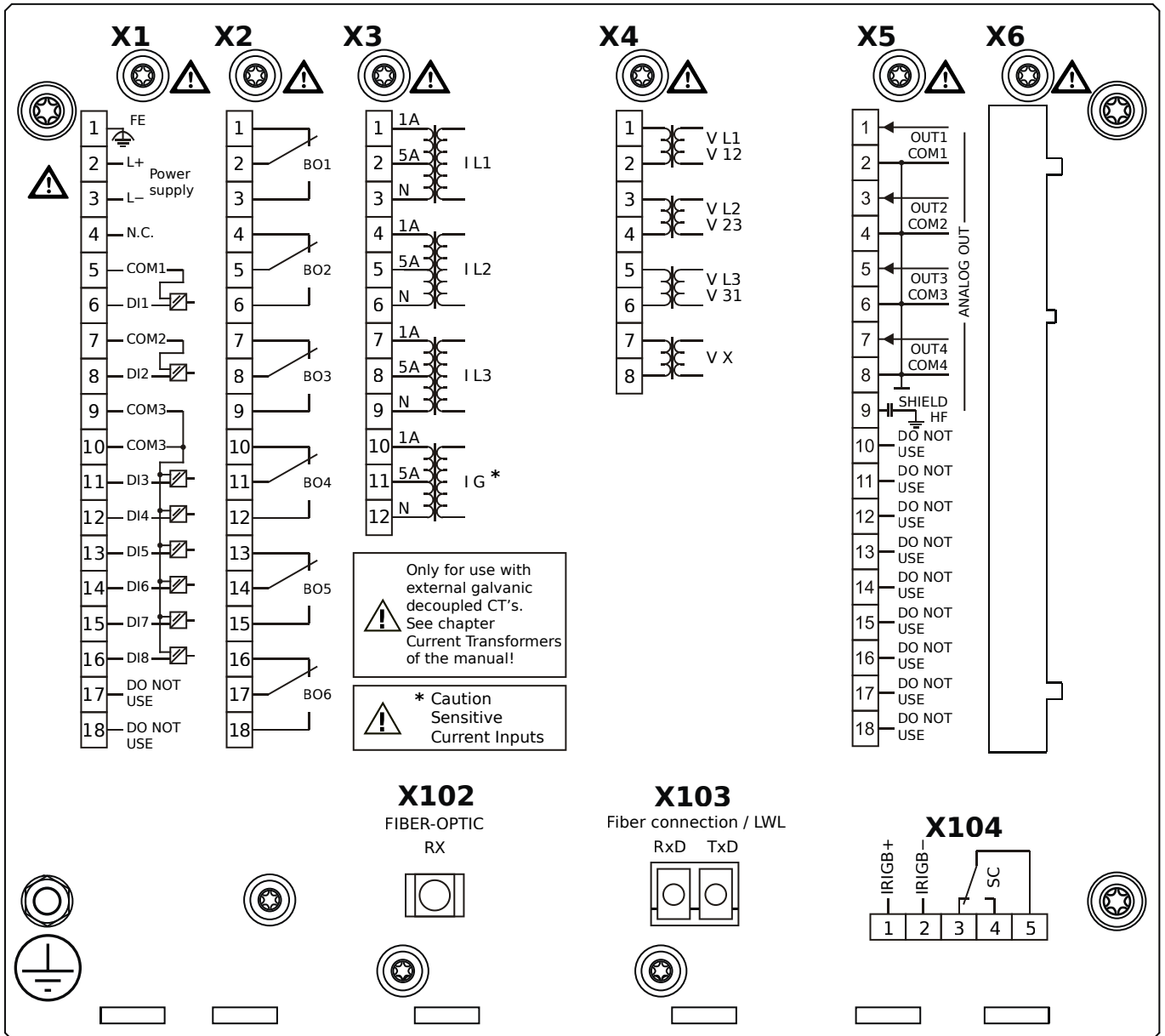

## Housing B2, small display, door mounting

- X1** – DI8-X1: Wide-range power supply unit, incl. 2 non-grouped digital inputs and 6 grouped digital inputs
- X2** – OR6: Assembly Group with 6 Output Relays (Changeover / Form C)
- X3** – TIs: Standard phase current measuring card and sensitive ground current measuring
- X4** – TU: Card with 4 voltage transformer measuring inputs (0 ... 800 VAC, under UL: 0 ... 600 VAC)
- X5** – AnO4: Analog Outputs
- X102** – Universal Resistance-Temperature Detector (URTD) input, Fiber optics interface, Versatile Link
- X103** – Modbus TCP / IEC 60870-5-104 / DNP3.0 TCP/UDP, Fiber optics interface, LC Connector
- X104** – IRIG-B00X, incl. System Contact (Supervision Contact)

# MRMV4-2A1ALB

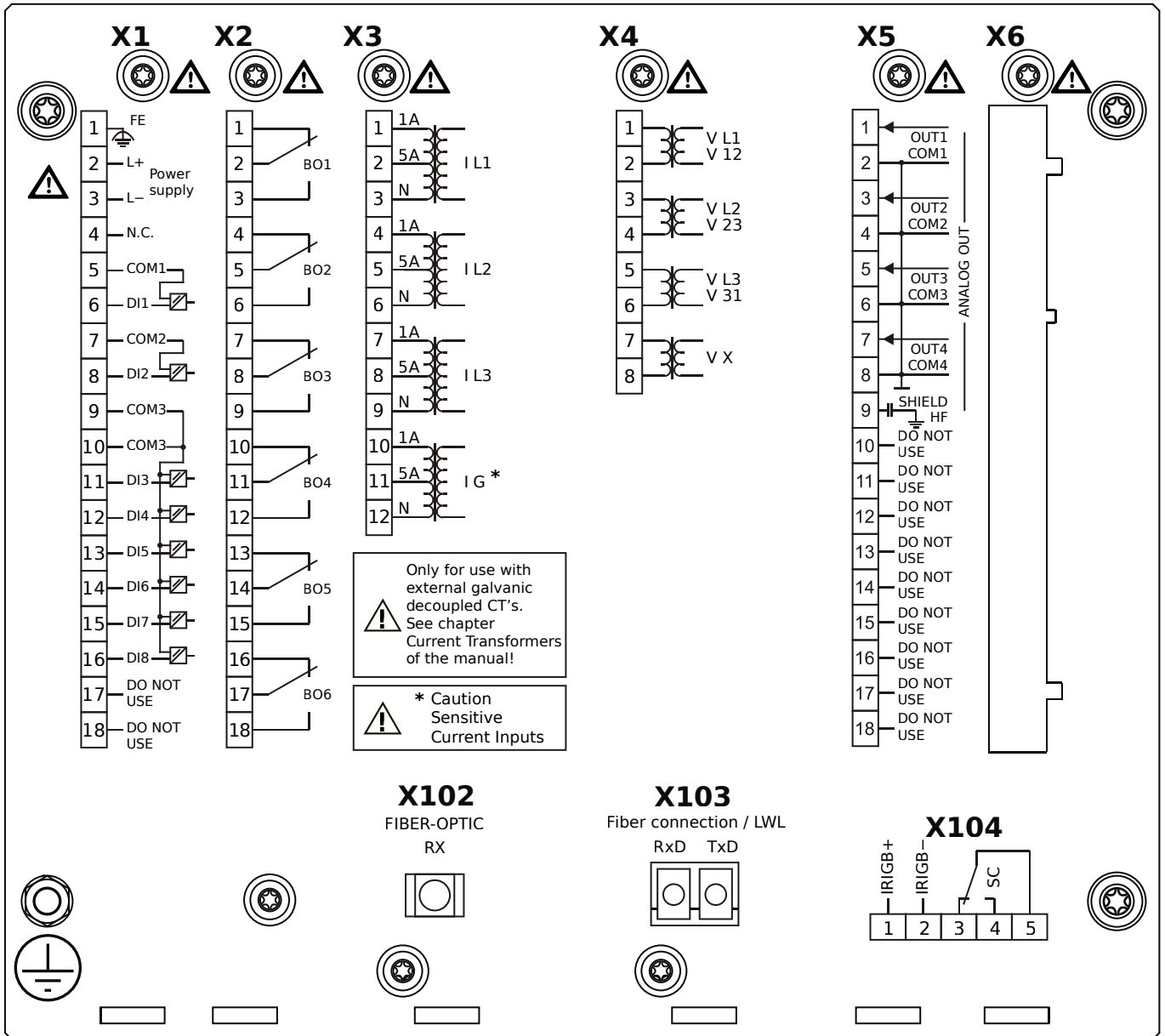

## Housing B2, small display, door mounting

+ Conformal Coating (for installations in harsh environment)

- X1** – DI8-X1: Wide-range power supply unit, incl. 2 non-grouped digital inputs and 6 grouped digital inputs
- X2** – OR6: Assembly Group with 6 Output Relays (Changeover / Form C)
- X3** – TIs: Standard phase current measuring card and sensitive ground current measuring
- X4** – TU: Card with 4 voltage transformer measuring inputs (0 ... 800 VAC, under UL: 0 ... 600 VAC)
- X5** – AnO4: Analog Outputs
- X102** – Universal Resistance-Temperature Detector (URTD) input, Fiber optics interface, Versatile Link
- X103** – Modbus TCP / IEC 60870-5-104 / DNP3.0 TCP/UDP, Fiber optics interface, LC Connector
- X104** – IRIG-B00X, incl. System Contact (Supervision Contact)

# MRMV4-2A1AOA

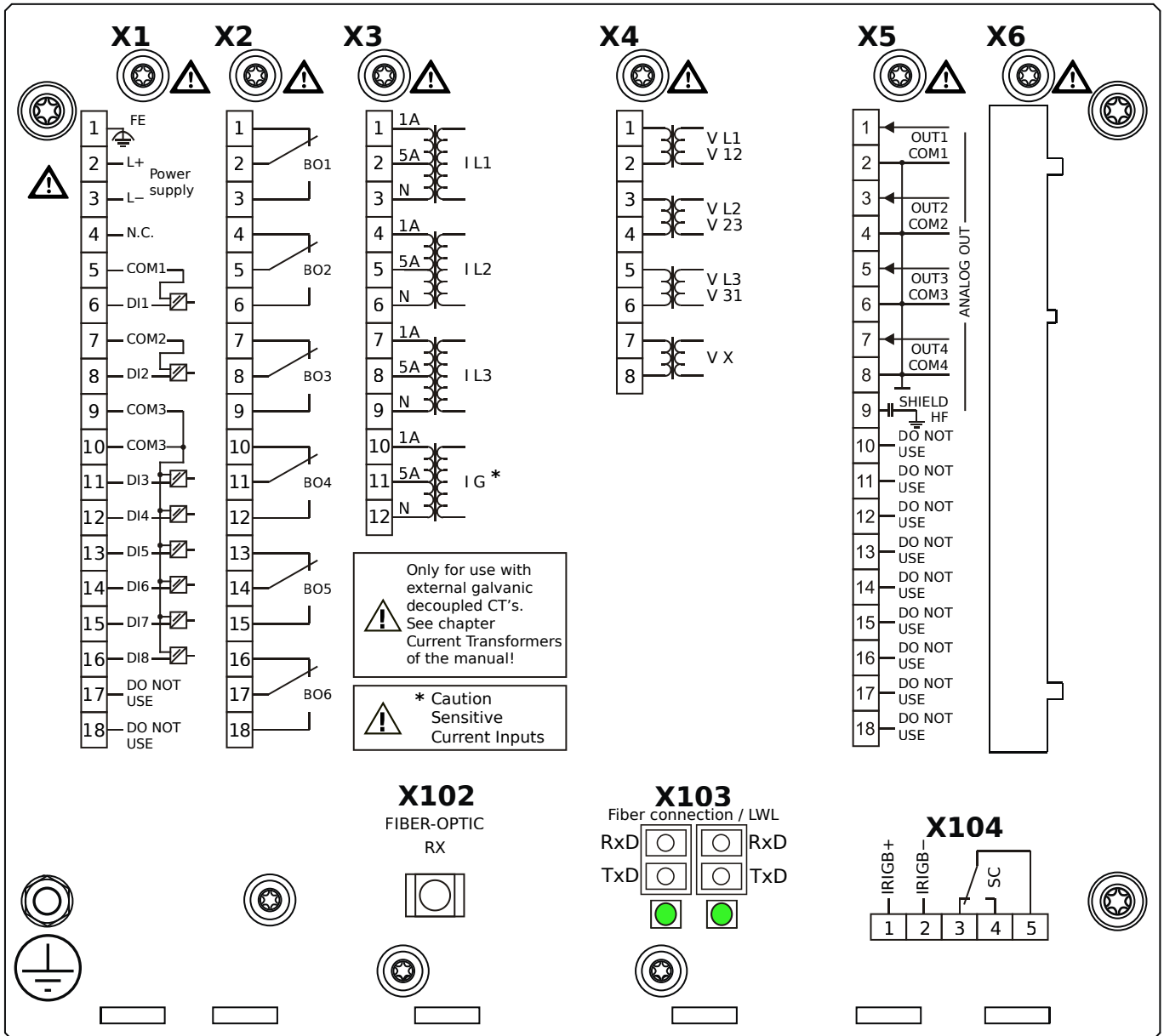

## Housing B2, small display, door mounting

- X1** – DI8-X1: Wide-range power supply unit, incl. 2 non-grouped digital inputs and 6 grouped digital inputs
- X2** – OR6: Assembly Group with 6 Output Relays (Changeover / Form C)
- X3** – TIs: Standard phase current measuring card and sensitive ground current measuring
- X4** – TU: Card with 4 voltage transformer measuring inputs (0 ... 800 VAC, under UL: 0 ... 600 VAC)
- X5** – AnO4: Analog Outputs
- X102** – Universal Resistance-Temperature Detector (URTD) input, Fiber optics interface, Versatile Link
- X103** – Modbus TCP / IEC 60870-5-104 / DNP3.0 TCP/UDP, Redundant Fiber optics interface, LC Connector
- X104** – IRIG-B00X, incl. System Contact (Supervision Contact)



# MRMV4-2A1AOB

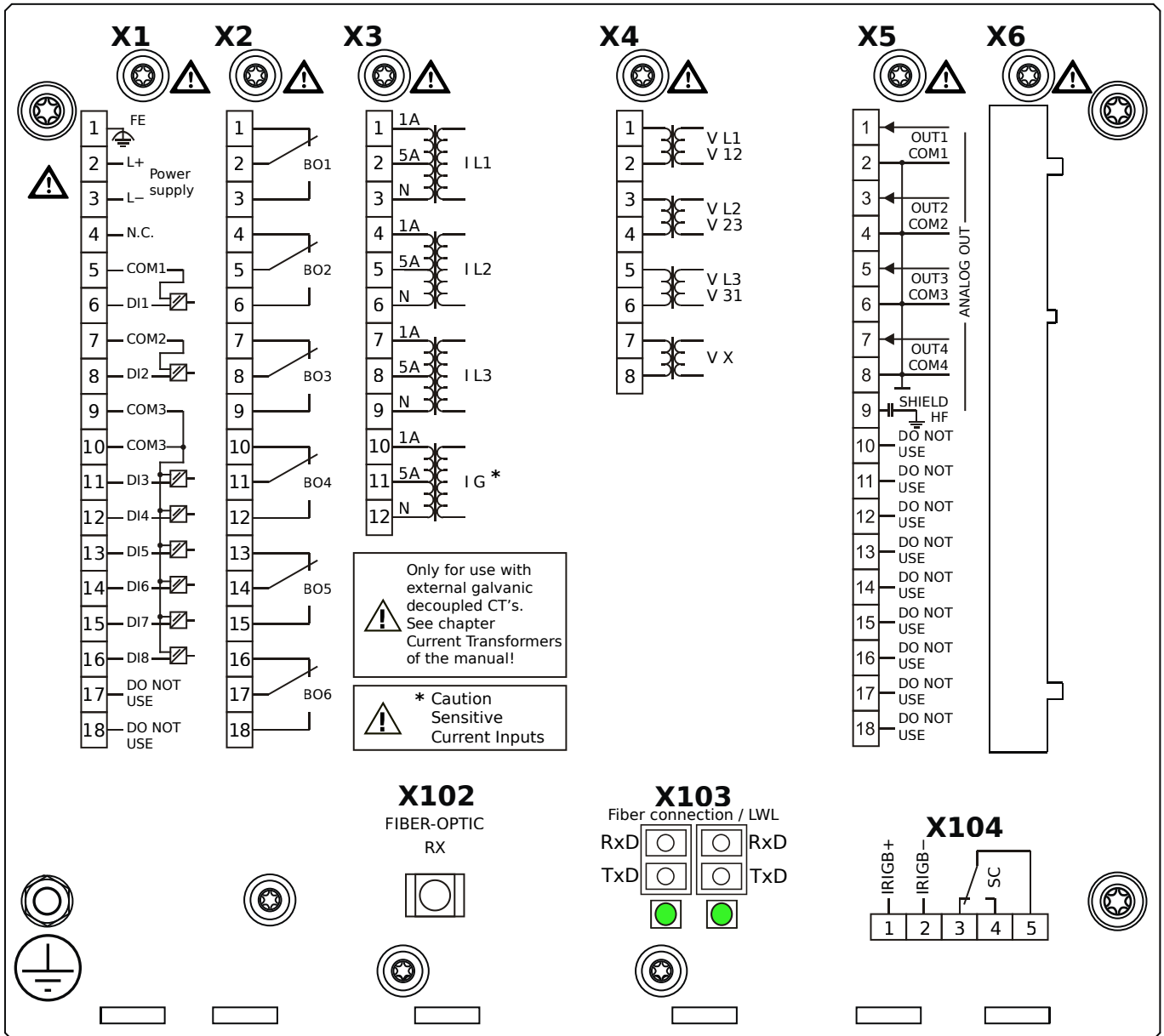

## Housing B2, small display, door mounting

+ Conformal Coating (for installations in harsh environment)

- X1** – DI8-X1: Wide-range power supply unit, incl. 2 non-grouped digital inputs and 6 grouped digital inputs
- X2** – OR6: Assembly Group with 6 Output Relays (Changeover / Form C)
- X3** – TIs: Standard phase current measuring card and sensitive ground current measuring
- X4** – TU: Card with 4 voltage transformer measuring inputs (0 ... 800 VAC, under UL: 0 ... 600 VAC)
- X5** – AnO4: Analog Outputs
- X102** – Universal Resistance-Temperature Detector (URTD) input, Fiber optics interface, Versatile Link
- X103** – Modbus TCP / IEC 60870-5-104 / DNP3.0 TCP/UDP, Redundant Fiber optics interface, LC Connector
- X104** – IRIG-B00X, incl. System Contact (Supervision Contact)

# MRMV4-2A1APA

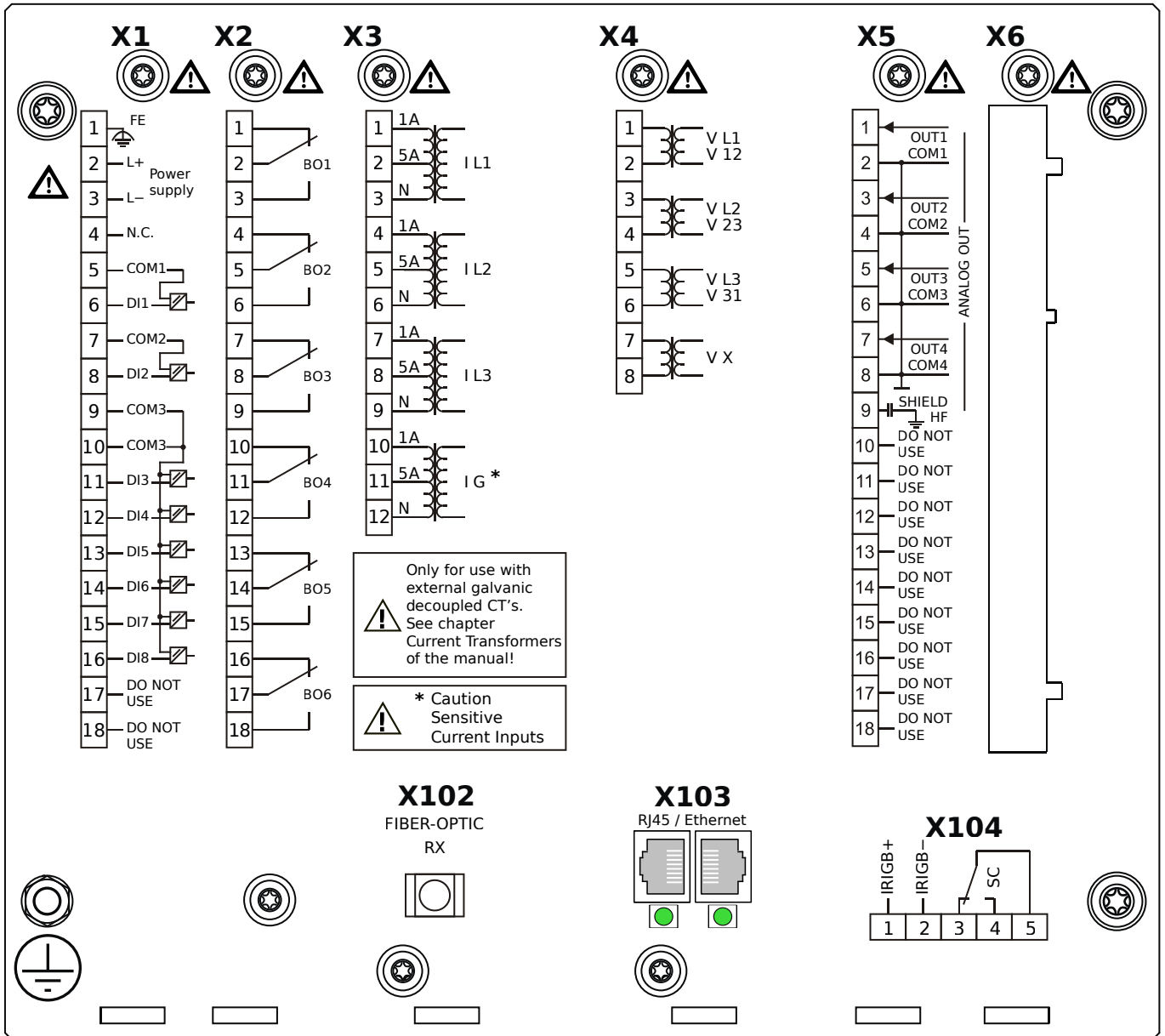

## Housing B2, small display, door mounting

- X1** – DI8-X1: Wide-range power supply unit, incl. 2 non-grouped digital inputs and 6 grouped digital inputs
- X2** – OR6: Assembly Group with 6 Output Relays (Changeover / Form C)
- X3** – TIs: Standard phase current measuring card and sensitive ground current measuring
- X4** – TU: Card with 4 voltage transformer measuring inputs (0 ... 800 VAC, under UL: 0 ... 600 VAC)
- X5** – AnO4: Analog Outputs
- X102** – Universal Resistance-Temperature Detector (URTD) input, Fiber optics interface, Versatile Link
- X103** – Modbus TCP / IEC 60870-5-104 / DNP3.0 TCP/UDP, Redundant Ethernet interface, 100 Mbit/s, RJ45 (BASE100-FX)
- X104** – IRIG-B00X, incl. System Contact (Supervision Contact)

# MRMV4-2A1APB

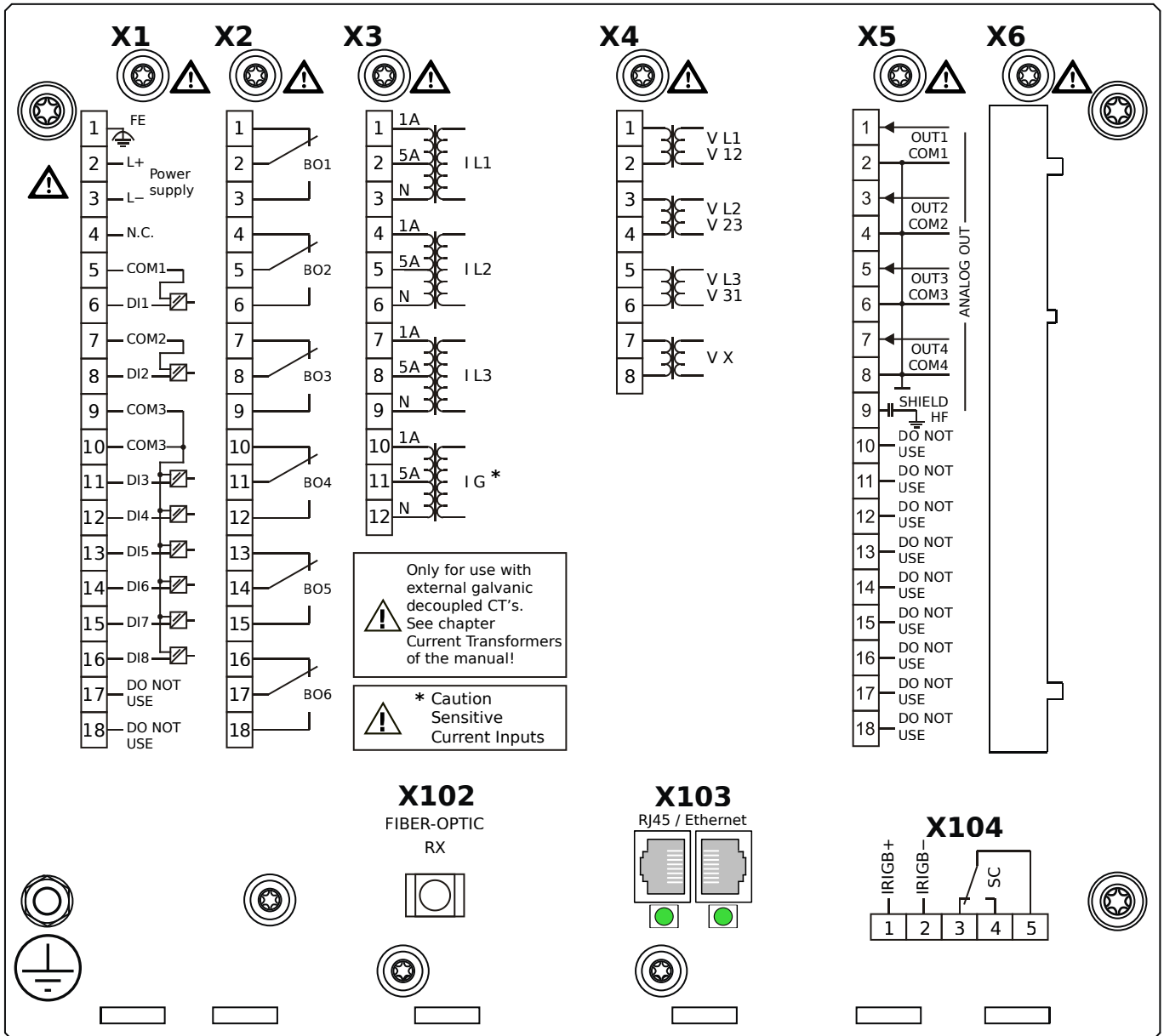

## Housing B2, small display, door mounting

+ Conformal Coating (for installations in harsh environment)

- X1** – DI8-X1: Wide-range power supply unit, incl. 2 non-grouped digital inputs and 6 grouped digital inputs
- X2** – OR6: Assembly Group with 6 Output Relays (Changeover / Form C)
- X3** – TIs: Standard phase current measuring card and sensitive ground current measuring
- X4** – TU: Card with 4 voltage transformer measuring inputs (0 ... 800 VAC, under UL: 0 ... 600 VAC)
- X5** – AnO4: Analog Outputs
- X102** – Universal Resistance-Temperature Detector (URTD) input, Fiber optics interface, Versatile Link
- X103** – Modbus TCP / IEC 60870-5-104 / DNP3.0 TCP/UDP, Redundant Ethernet interface, 100 Mbit/s, RJ45 (BASE100-FX)
- X104** – IRIG-B00X, incl. System Contact (Supervision Contact)

# MRMV4-2A1AQA

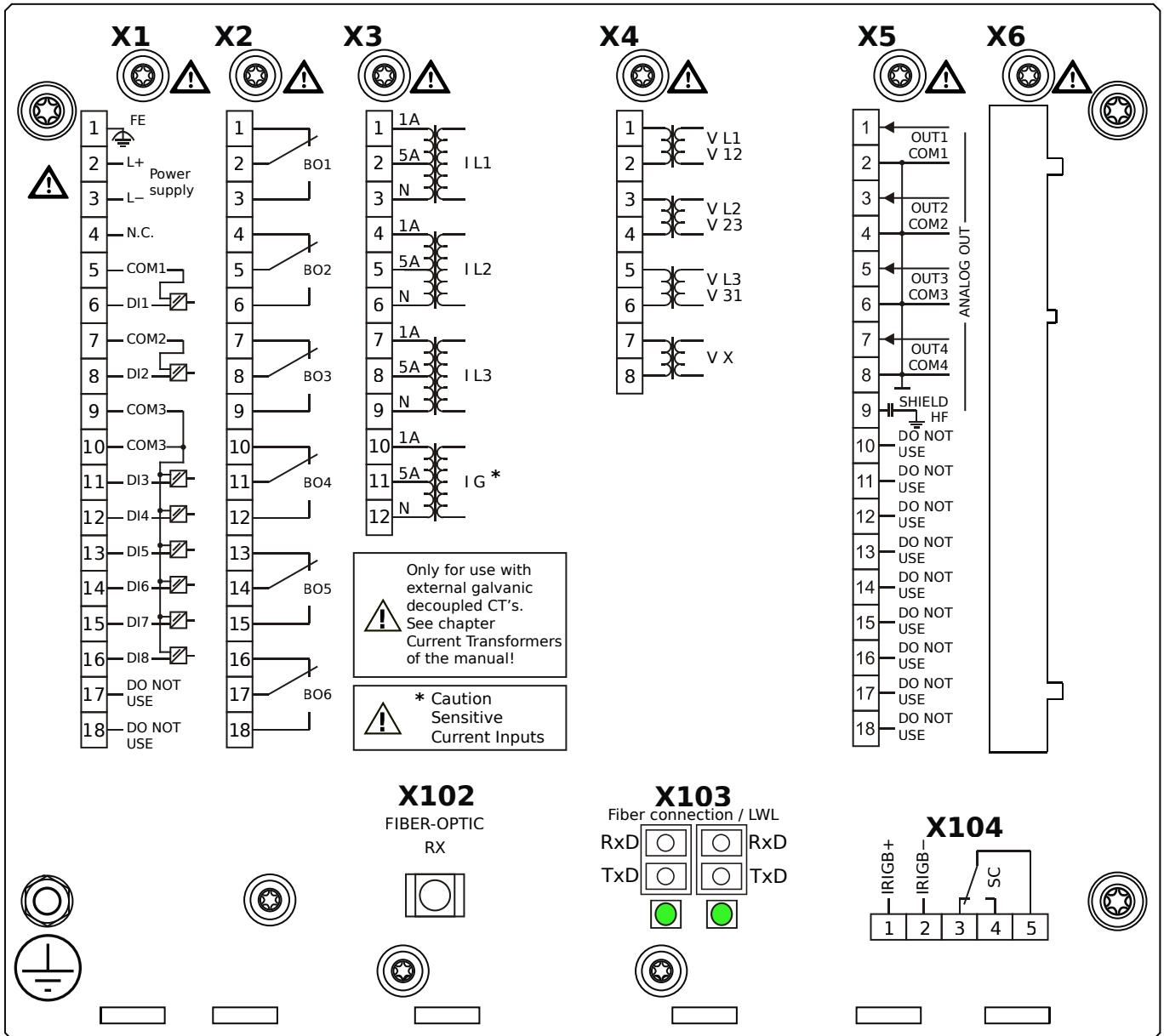

## Housing B2, small display, door mounting

- X1** – DI8-X1: Wide-range power supply unit, incl. 2 non-grouped digital inputs and 6 grouped digital inputs
- X2** – OR6: Assembly Group with 6 Output Relays (Changeover / Form C)
- X3** – TIs: Standard phase current measuring card and sensitive ground current measuring
- X4** – TU: Card with 4 voltage transformer measuring inputs (0 ... 800 VAC, under UL: 0 ... 600 VAC)
- X5** – AnO4: Analog Outputs
- X102** – Universal Resistance-Temperature Detector (URTD) input, Fiber optics interface, Versatile Link
- X103** – IEC 61850 / Modbus TCP / IEC 60870-5-104 / DNP3.0 TCP/UDP, Redundant Fiber optics interface, LC Connector
- X104** – IRIG-B00X, incl. System Contact (Supervision Contact)

# MRMV4-2A1AQB

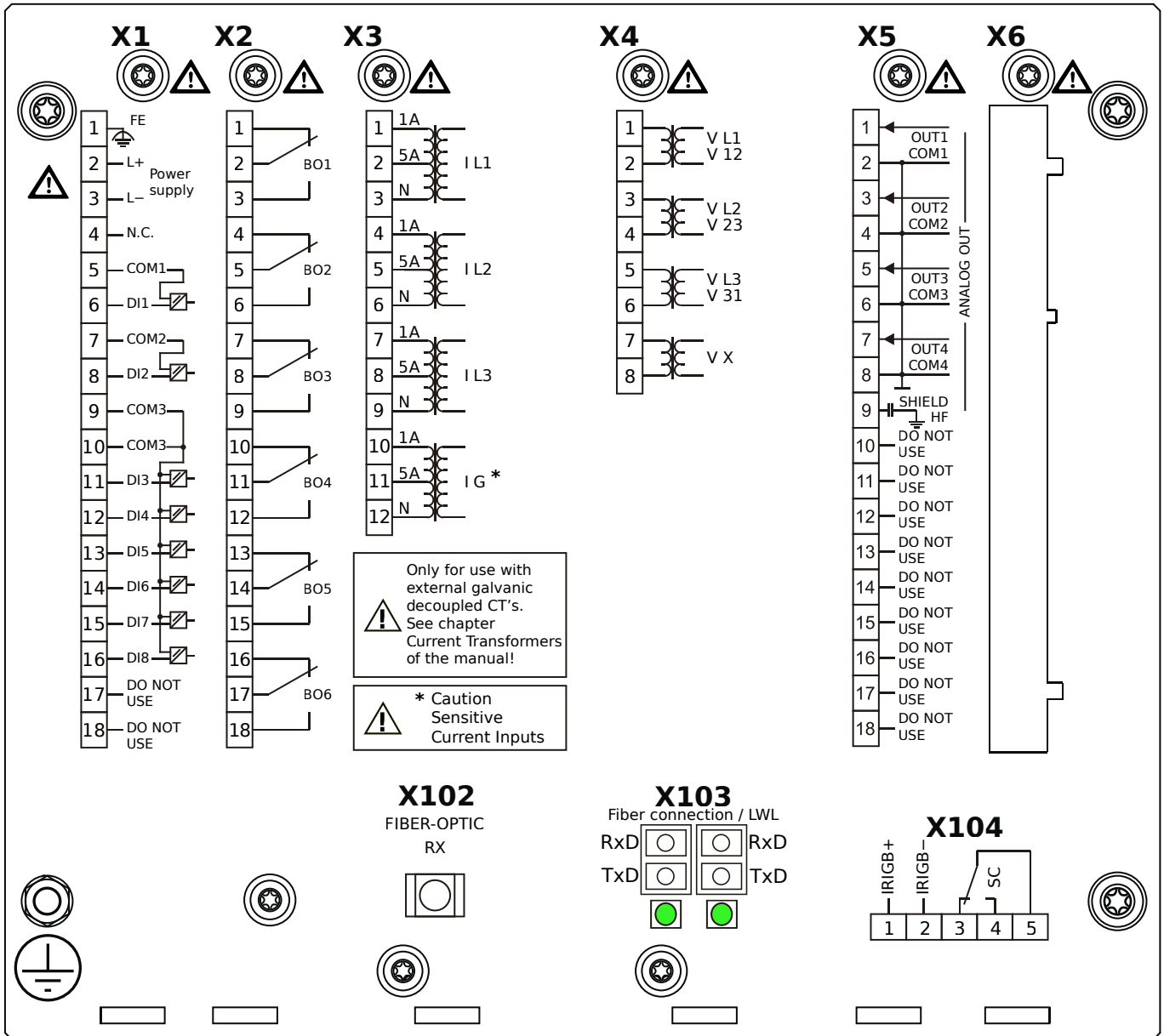

## Housing B2, small display, door mounting

- + Conformal Coating (for installations in harsh environment)

- X1** – DI8-X1: Wide-range power supply unit, incl. 2 non-grouped digital inputs and 6 grouped digital inputs
- X2** – OR6: Assembly Group with 6 Output Relays (Changeover / Form C)
- X3** – TIs: Standard phase current measuring card and sensitive ground current measuring
- X4** – TU: Card with 4 voltage transformer measuring inputs (0 ... 800 VAC, under UL: 0 ... 600 VAC)
- X5** – AnO4: Analog Outputs
- X102** – Universal Resistance-Temperature Detector (URTD) input, Fiber optics interface, Versatile Link
- X103** – IEC 61850 / Modbus TCP / IEC 60870-5-104 / DNP3.0 TCP/UDP, Redundant Fiber optics interface, LC Connector
- X104** – IRIG-B00X, incl. System Contact (Supervision Contact)

# MRMV4-2A1ARA

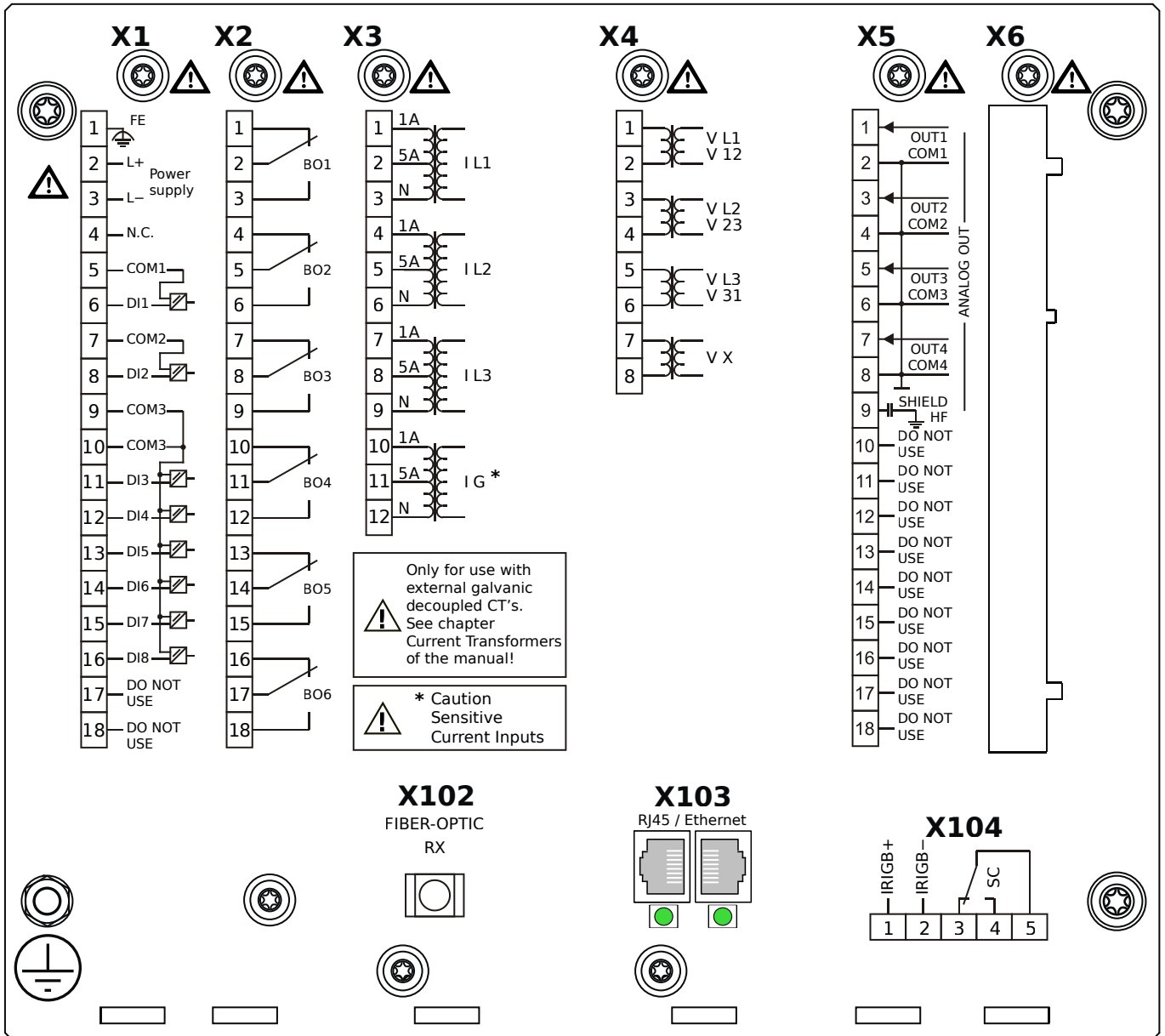

## Housing B2, small display, door mounting

**X1** – DI8-X1: Wide-range power supply unit, incl. 2 non-grouped digital inputs and 6 grouped digital inputs

**X2** – OR6: Assembly Group with 6 Output Relays (Changeover / Form C)

**X3** – TIs: Standard phase current measuring card and sensitive ground current measuring

**X4** – TU: Card with 4 voltage transformer measuring inputs (0 ... 800 VAC, under UL: 0 ... 600 VAC)

**X5** – AnO4: Analog Outputs

**X102** – Universal Resistance-Temperature Detector (URTD) input, Fiber optics interface, Versatile Link

**X103** – IEC 61850 / Modbus TCP / IEC 60870-5-104 / DNP3.0 TCP/UDP, Redundant Ethernet interface, 100 Mbit/s, RJ45

(BASE100-FX)

**X104** – IRIG-B00X, incl. System Contact (Supervision Contact)

# MRMV4-2A1ARB

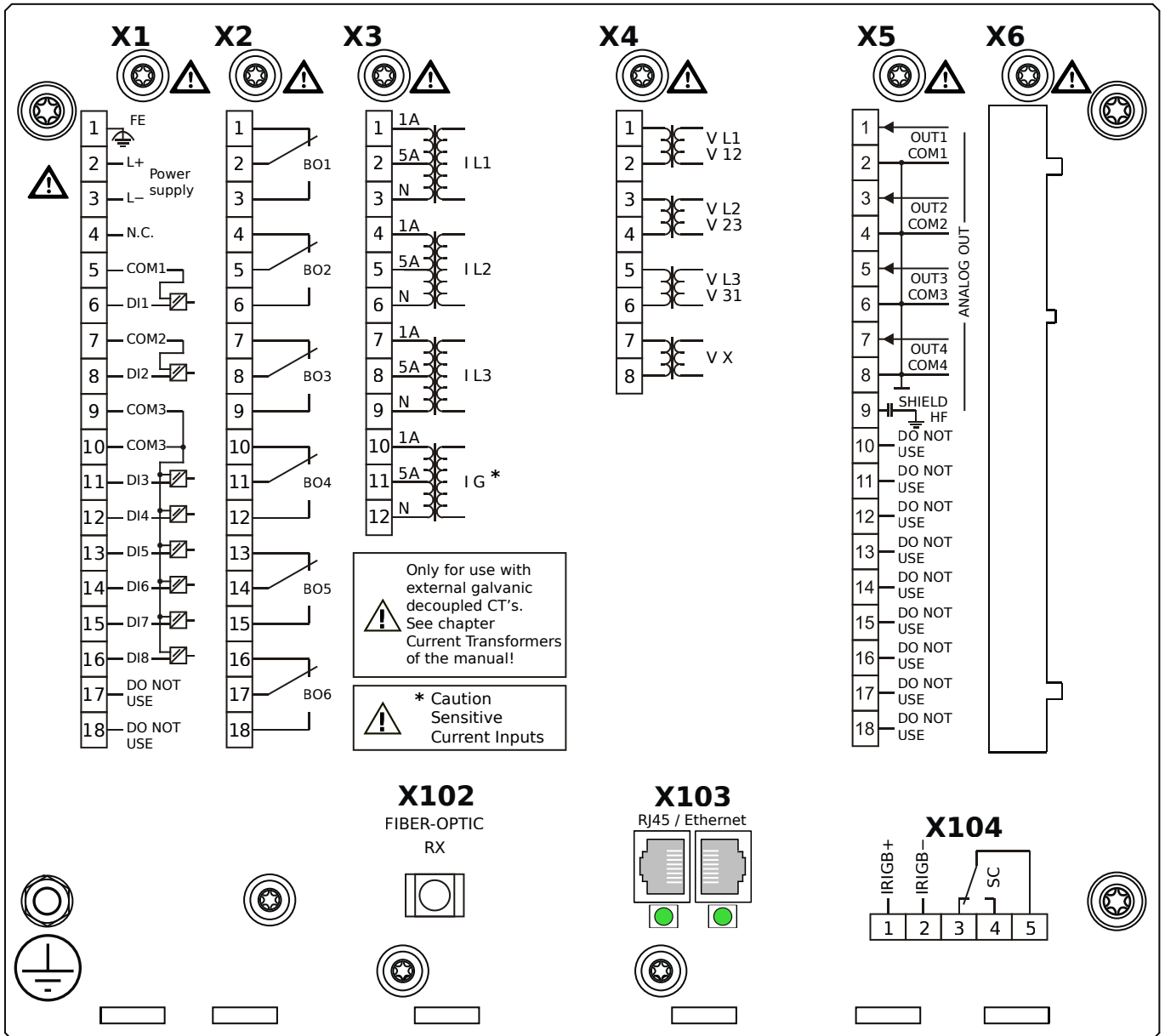

## Housing B2, small display, door mounting

+ Conformal Coating (for installations in harsh environment)

**X1** – DI8-X1: Wide-range power supply unit, incl. 2 non-grouped digital inputs and 6 grouped digital inputs

**X2** – OR6: Assembly Group with 6 Output Relays (Changeover / Form C)

**X3** – TIs: Standard phase current measuring card and sensitive ground current measuring

**X4** – TU: Card with 4 voltage transformer measuring inputs (0 ... 800 VAC, under UL: 0 ... 600 VAC)

**X5** – AnO4: Analog Outputs

**X102** – Universal Resistance-Temperature Detector (URTD) input, Fiber optics interface, Versatile Link

**X103** – IEC 61850 / Modbus TCP / IEC 60870-5-104 / DNP3.0 TCP/UDP, Redundant Ethernet interface, 100 Mbit/s, RJ45

(BASE100-FX)

**X104** – IRIG-B00X, incl. System Contact (Supervision Contact)

# MRMV4-2A1ATA

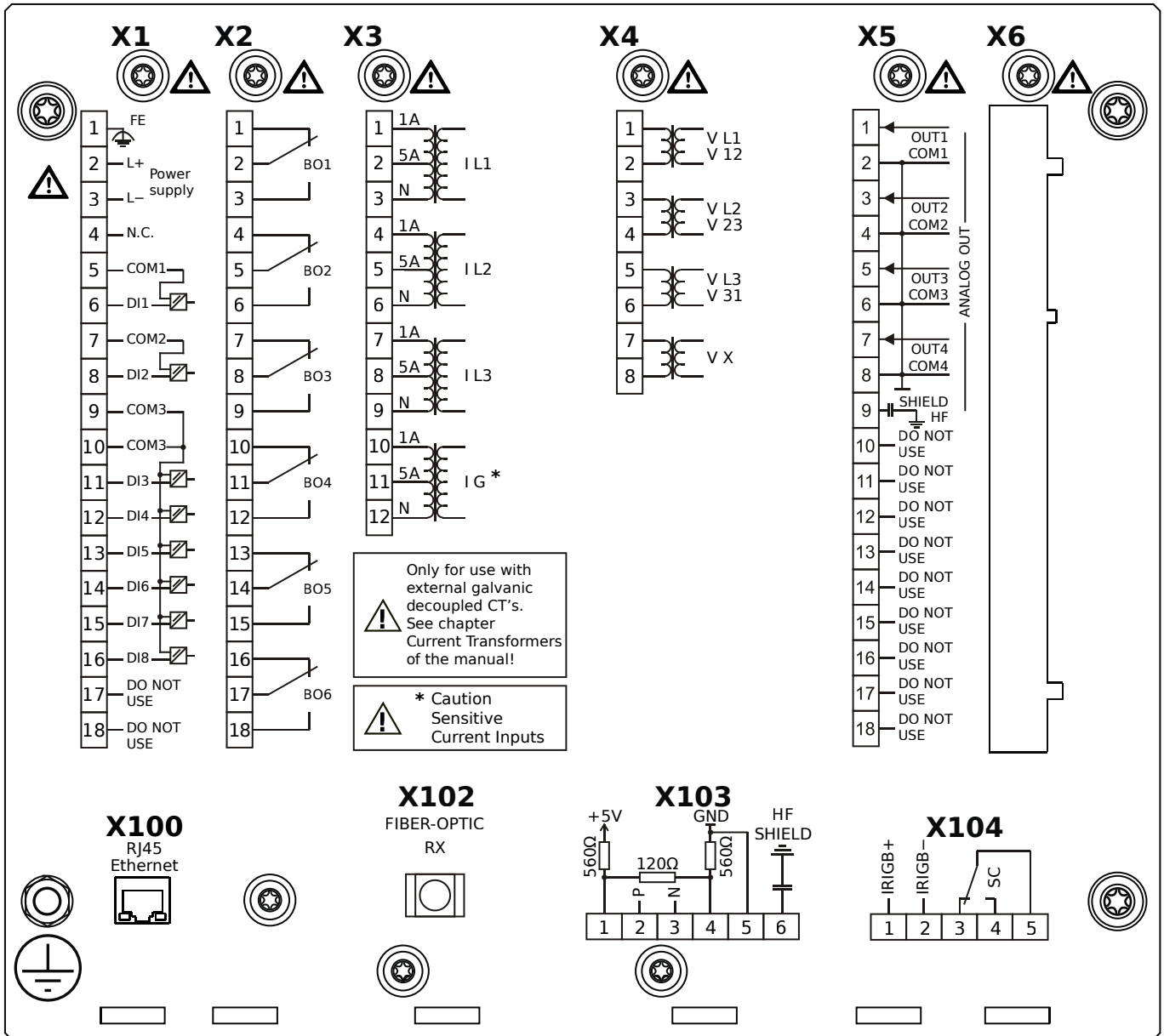

## Housing B2, small display, door mounting

- X1** – DI8-X1: Wide-range power supply unit, incl. 2 non-grouped digital inputs and 6 grouped digital inputs
- X2** – OR6: Assembly Group with 6 Output Relays (Changeover / Form C)
- X3** – TIs: Standard phase current measuring card and sensitive ground current measuring
- X4** – TU: Card with 4 voltage transformer measuring inputs (0 ... 800 VAC, under UL: 0 ... 600 VAC)
- X5** – AnO4: Analog Outputs
- X100** – IEC 61850 / Modbus TCP / IEC 60870-5-104 / DNP3.0 TCP/UDP, Ethernet interface, 100 Mbit/s, RJ45 (BASE100-FX)
- X102** – Universal Resistance-Temperature Detector (URTD) input, Fiber optics interface, Versatile Link
- X103** – IEC 60870-5-103 / Modbus RTU / DNP3.0 RTU, RS485, Terminals
- X104** – IRIG-B00X, incl. System Contact (Supervision Contact)



# MRMV4-2A1ATB

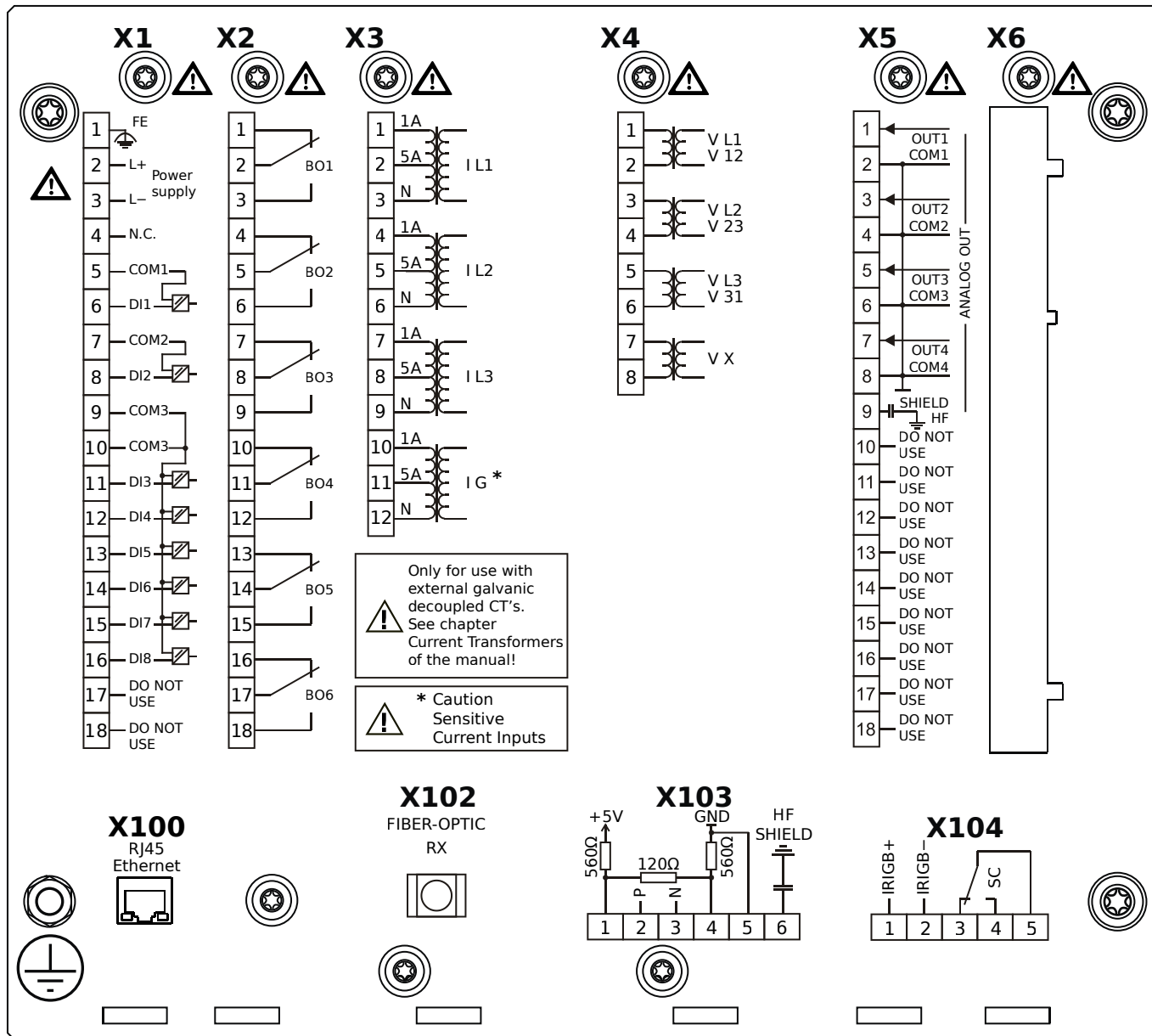

## Housing B2, small display, door mounting

+ Conformal Coating (for installations in harsh environment)

**X1** – DI8-X1: Wide-range power supply unit, incl. 2 non-grouped digital inputs and 6 grouped digital inputs

**X2** – OR6: Assembly Group with 6 Output Relays (Changeover / Form C)

**X3** – TIs: Standard phase current measuring card and sensitive ground current measuring

**X4** – TU: Card with 4 voltage transformer measuring inputs (0 ... 800 VAC, under UL: 0 ... 600 VAC)

**X5** – AnO4: Analog Outputs

**X100** – IEC 61850 / Modbus TCP / IEC 60870-5-104 / DNP3.0 TCP/UDP, Ethernet interface, 100 Mbit/s, RJ45 (BASE100-

FX)

**X102** – Universal Resistance-Temperature Detector (URTD) input, Fiber optics interface, Versatile Link

**X103** – IEC 60870-5-103 / Modbus RTU / DNP3.0 RTU, RS485, Terminals

**X104** – IRIG-B00X, incl. System Contact (Supervision Contact)

# MRMV4-2A1BAA

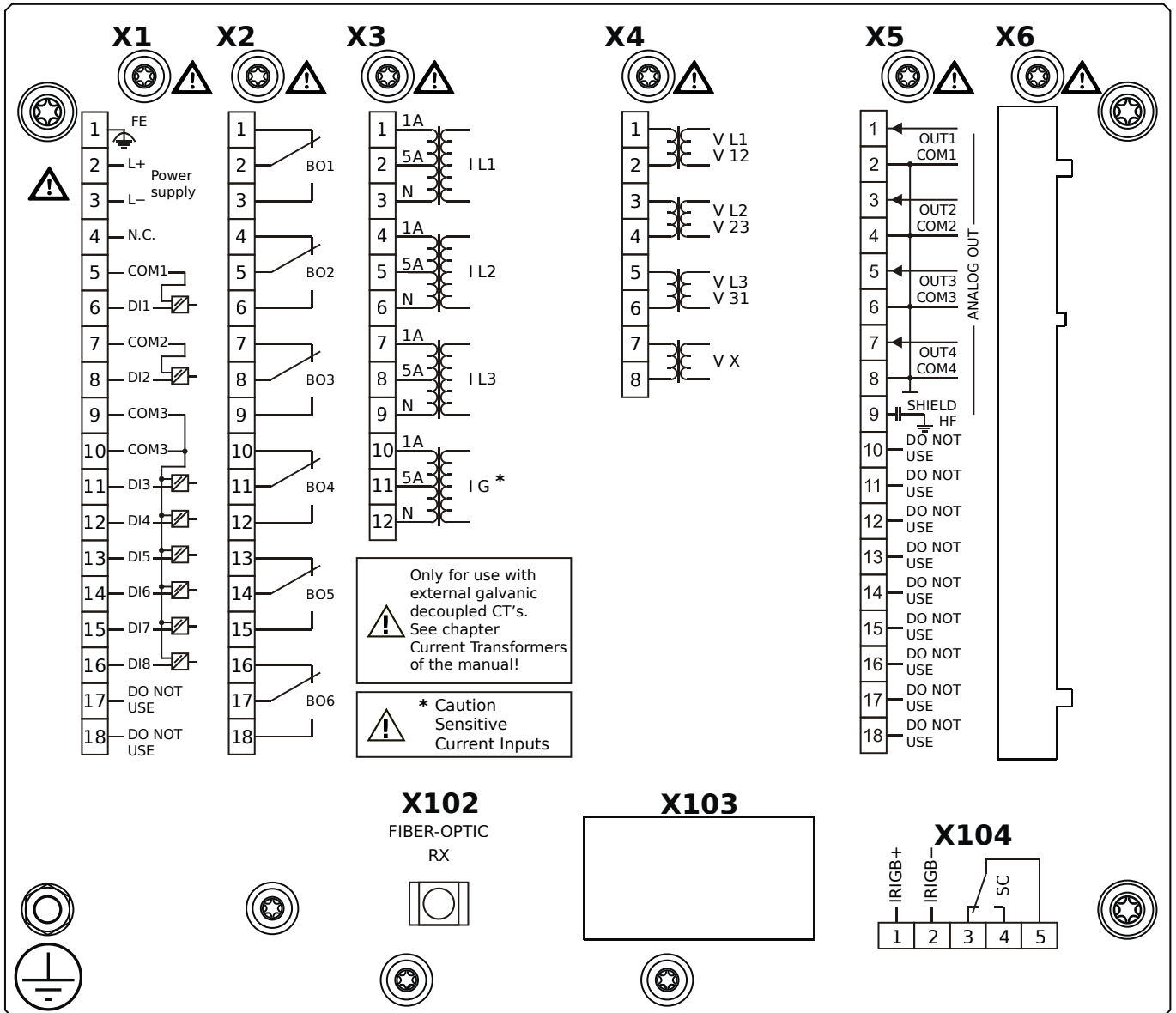

## Housing B2, small display, 19" rack mounting

- X1** – DI8-X1: Wide-range power supply unit, incl. 2 non-grouped digital inputs and 6 grouped digital inputs
- X2** – OR6: Assembly Group with 6 Output Relays (Changeover / Form C)
- X3** – TIs: Standard phase current measuring card and sensitive ground current measuring
- X4** – TU: Card with 4 voltage transformer measuring inputs (0 ... 800 VAC, under UL: 0 ... 600 VAC)
- X5** – AnO4: Analog Outputs
- X102** – Universal Resistance-Temperature Detector (URTD) input, Fiber optics interface, Versatile Link
- X104** – IRIG-B00X, incl. System Contact (Supervision Contact)

# MRMV4-2A1BAB

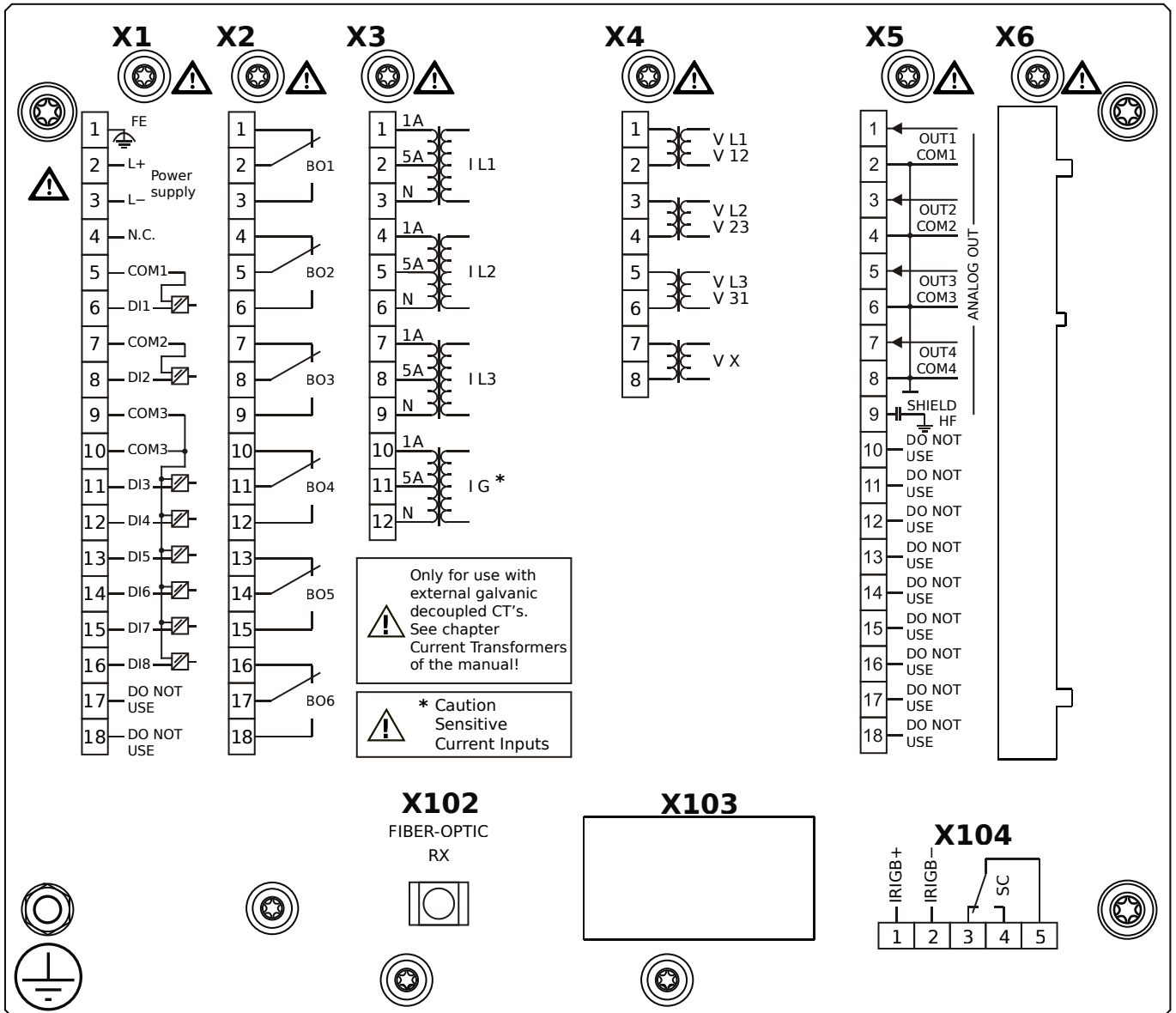

## Housing B2, small display, 19" rack mounting

+ Conformal Coating (for installations in harsh environment)

- X1** – DI8-X1: Wide-range power supply unit, incl. 2 non-grouped digital inputs and 6 grouped digital inputs
- X2** – OR6: Assembly Group with 6 Output Relays (Changeover / Form C)
- X3** – TIs: Standard phase current measuring card and sensitive ground current measuring
- X4** – TU: Card with 4 voltage transformer measuring inputs (0 ... 800 VAC, under UL: 0 ... 600 VAC)
- X5** – AnO4: Analog Outputs
- X102** – Universal Resistance-Temperature Detector (URTD) input, Fiber optics interface, Versatile Link
- X104** – IRIG-B00X, incl. System Contact (Supervision Contact)

# MRMV4-2A1BBA

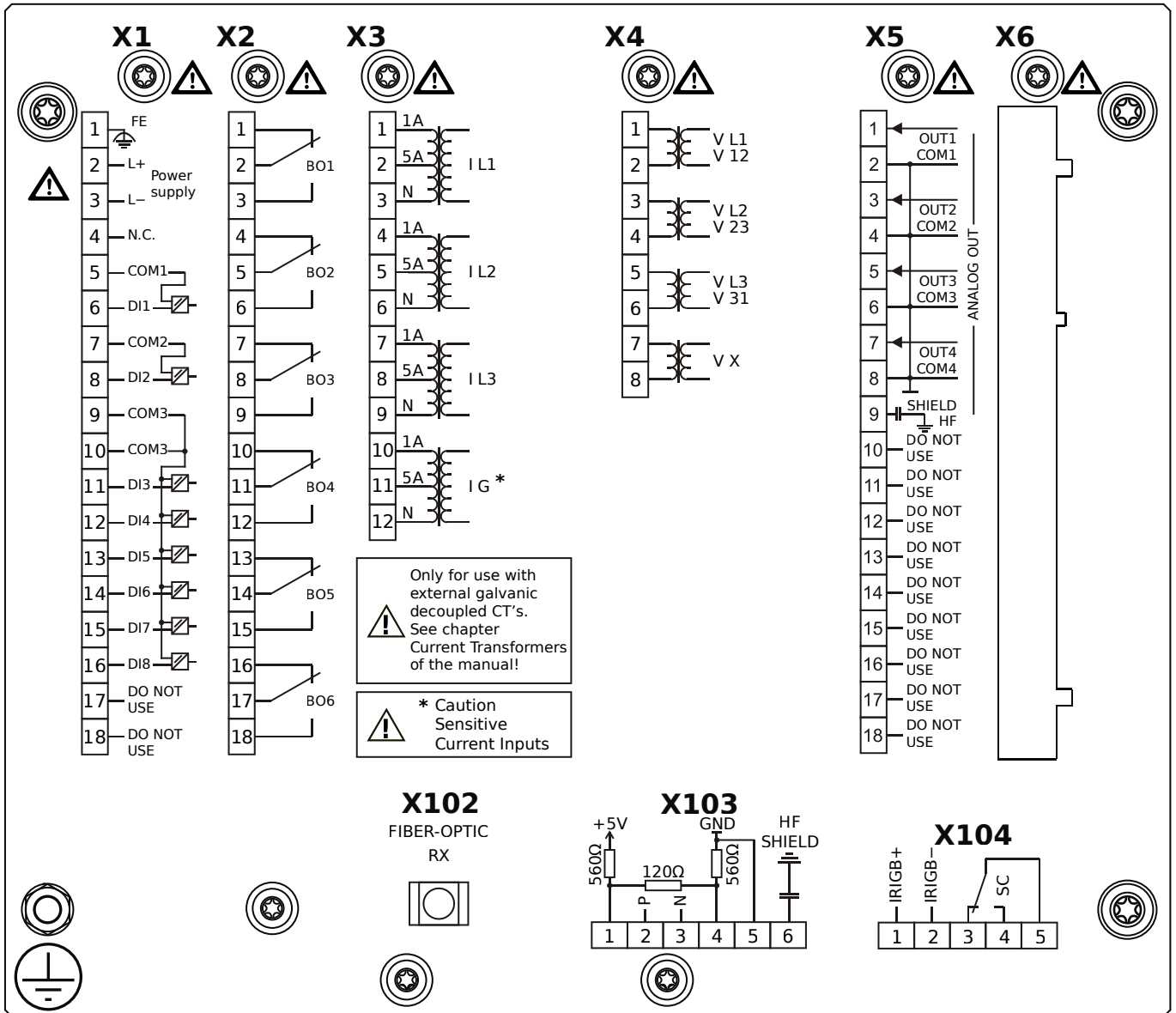

## Housing B2, small display, 19" rack mounting

- X1** – DI8-X1: Wide-range power supply unit, incl. 2 non-grouped digital inputs and 6 grouped digital inputs
- X2** – OR6: Assembly Group with 6 Output Relays (Changeover / Form C)
- X3** – TIs: Standard phase current measuring card and sensitive ground current measuring
- X4** – TU: Card with 4 voltage transformer measuring inputs (0 ... 800 VAC, under UL: 0 ... 600 VAC)
- X5** – AnO4: Analog Outputs
- X102** – Universal Resistance-Temperature Detector (URTD) input, Fiber optics interface, Versatile Link
- X103** – Modbus RTU / IEC 60870-5-103 / DNP3.0 RTU, RS485, Terminals
- X104** – IRIG-B00X, incl. System Contact (Supervision Contact)

# MRMV4-2A1BBB

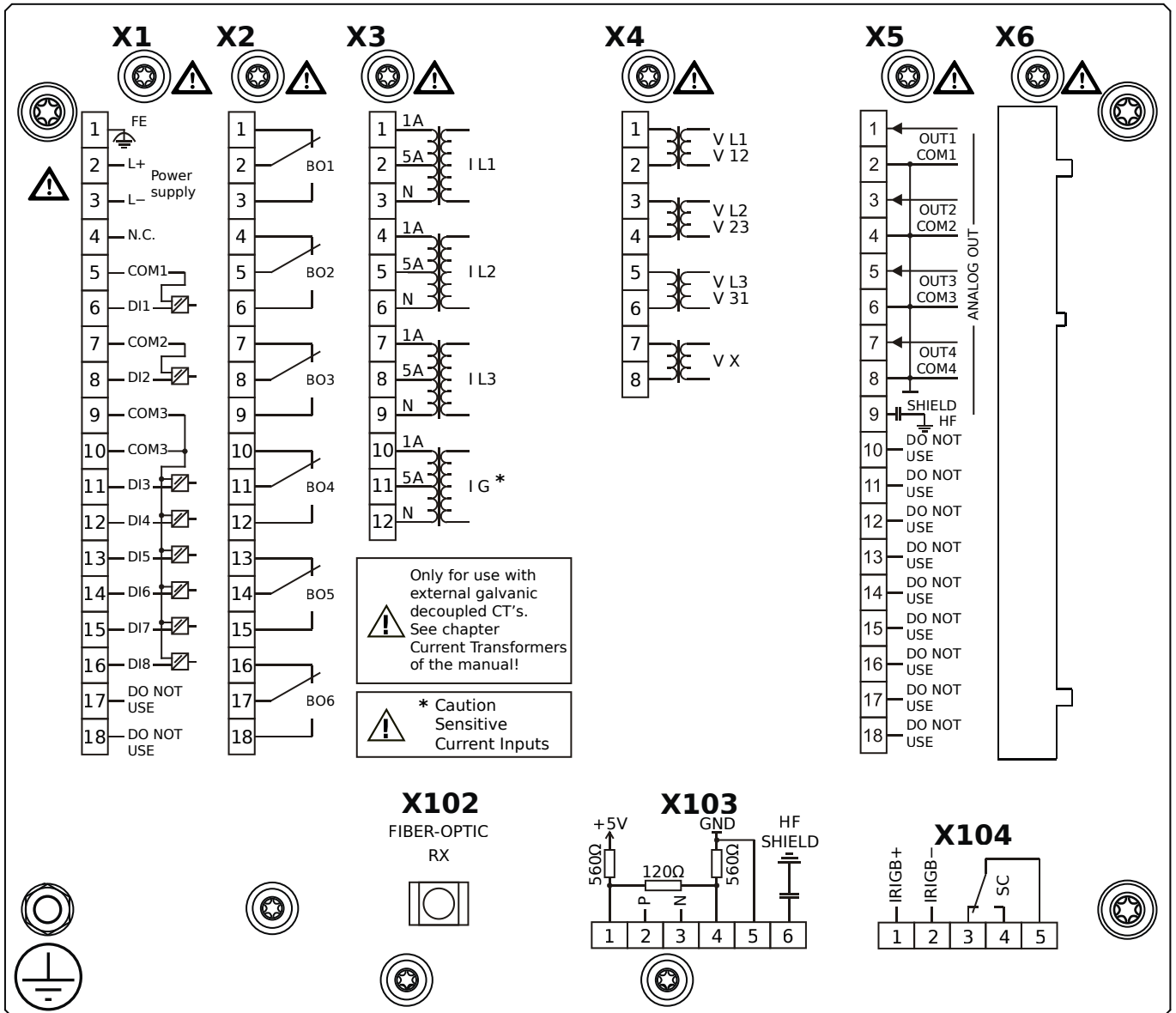

## Housing B2, small display, 19" rack mounting

+ Conformal Coating (for installations in harsh environment)

- X1** – DI8-X1: Wide-range power supply unit, incl. 2 non-grouped digital inputs and 6 grouped digital inputs
- X2** – OR6: Assembly Group with 6 Output Relays (Changeover / Form C)
- X3** – TIs: Standard phase current measuring card and sensitive ground current measuring
- X4** – TU: Card with 4 voltage transformer measuring inputs (0 ... 800 VAC, under UL: 0 ... 600 VAC)
- X5** – AnO4: Analog Outputs
- X102** – Universal Resistance-Temperature Detector (URTD) input, Fiber optics interface, Versatile Link
- X103** – Modbus RTU / IEC 60870-5-103 / DNP3.0 RTU, RS485, Terminals
- X104** – IRIG-B00X, incl. System Contact (Supervision Contact)

# MRMV4-2A1BCA

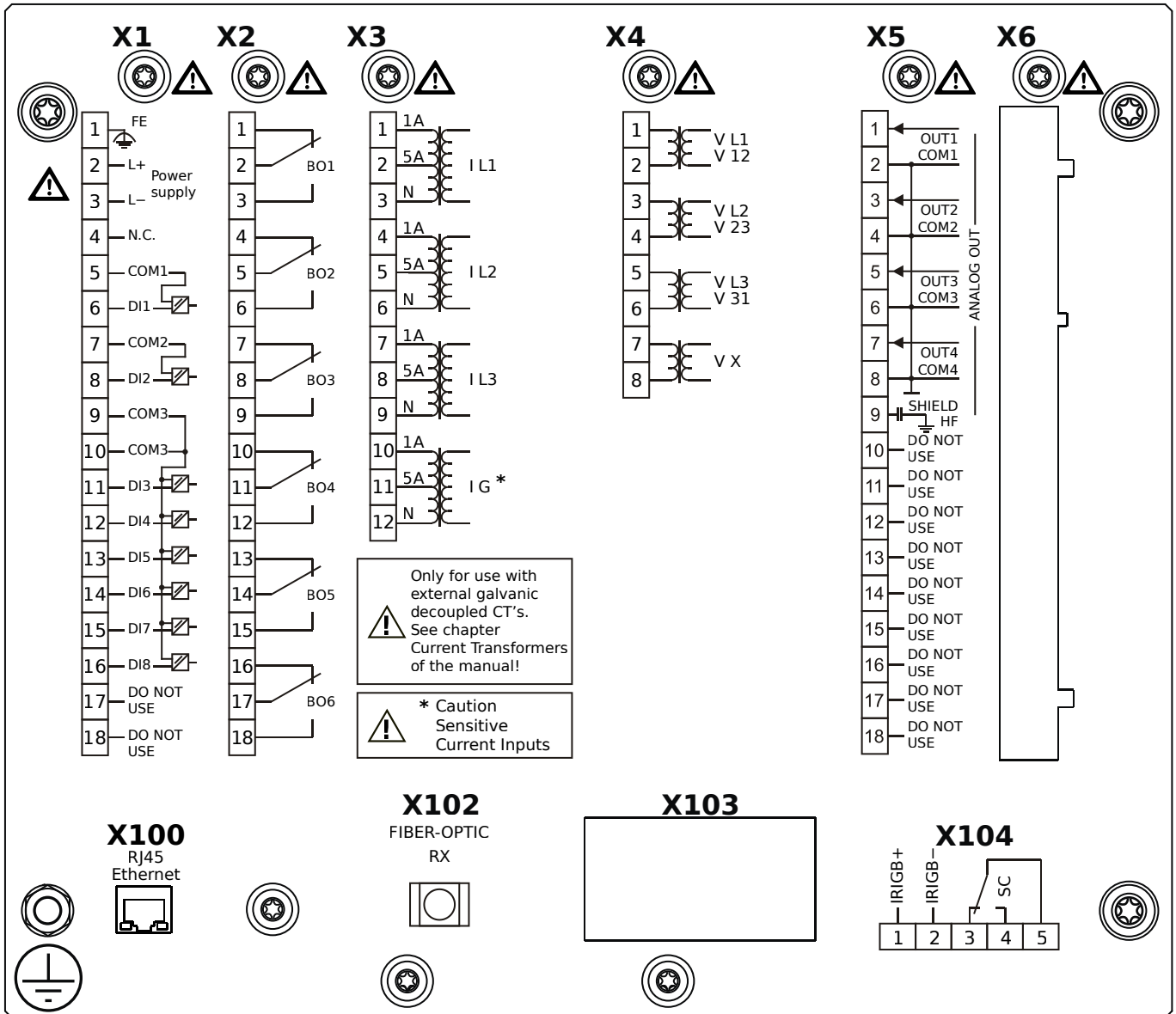

## Housing B2, small display, 19" rack mounting

- X1** – DI8-X1: Wide-range power supply unit, incl. 2 non-grouped digital inputs and 6 grouped digital inputs
- X2** – OR6: Assembly Group with 6 Output Relays (Changeover / Form C)
- X3** – TIs: Standard phase current measuring card and sensitive ground current measuring
- X4** – TU: Card with 4 voltage transformer measuring inputs (0 ... 800 VAC, under UL: 0 ... 600 VAC)
- X5** – AnO4: Analog Outputs
- X100** – Modbus TCP / IEC 60870-5-104 / DNP3.0 TCP/UDP, Ethernet interface, 100 Mbit/s, RJ45 (BASE100-FX)
- X102** – Universal Resistance-Temperature Detector (URTD) input, Fiber optics interface, Versatile Link
- X104** – IRIG-B00X, incl. System Contact (Supervision Contact)

# MRMV4-2A1BCB

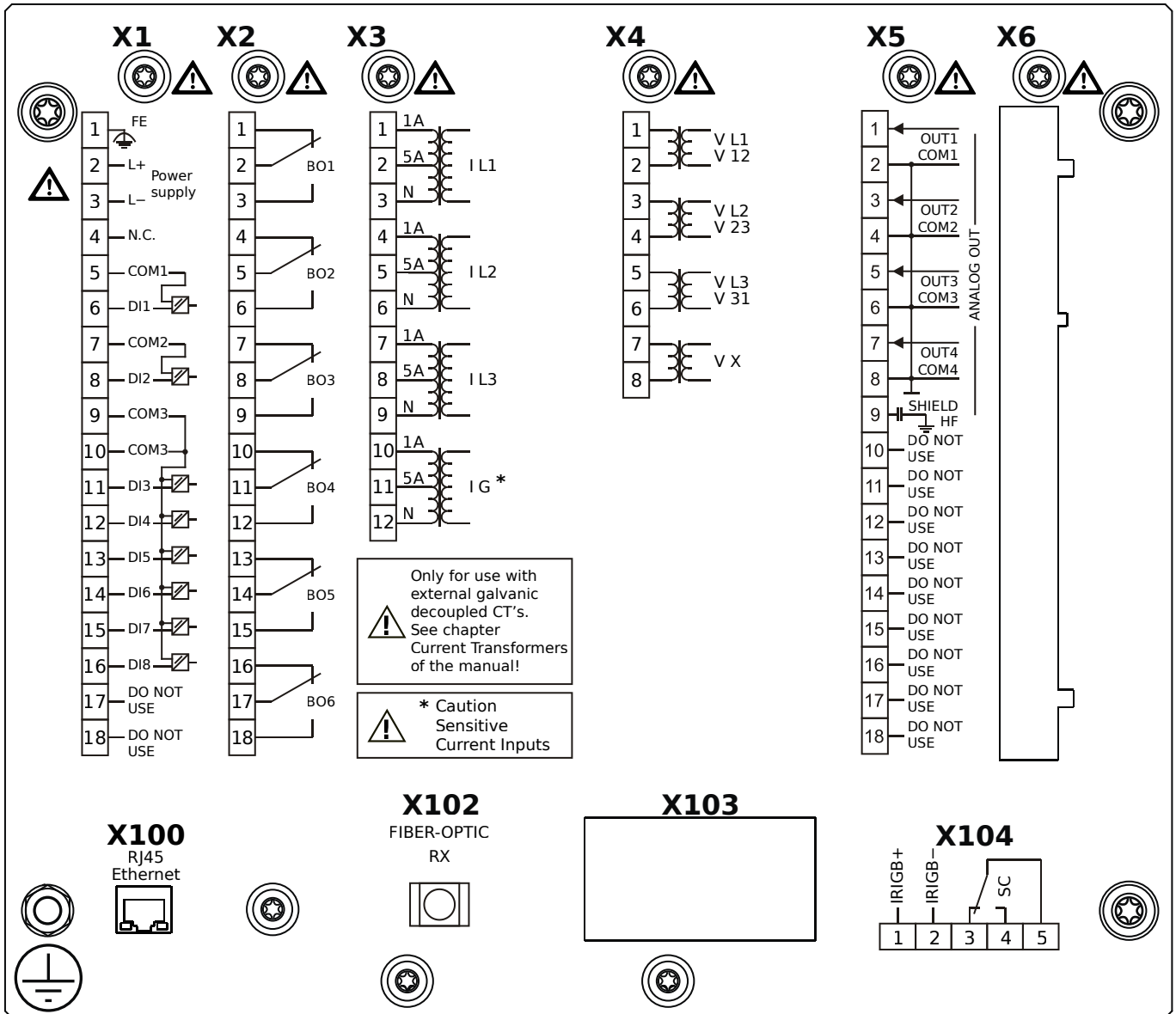

## Housing B2, small display, 19" rack mounting

+ Conformal Coating (for installations in harsh environment)

- X1** – DI8-X1: Wide-range power supply unit, incl. 2 non-grouped digital inputs and 6 grouped digital inputs
- X2** – OR6: Assembly Group with 6 Output Relays (Changeover / Form C)
- X3** – TIs: Standard phase current measuring card and sensitive ground current measuring
- X4** – TU: Card with 4 voltage transformer measuring inputs (0 ... 800 VAC, under UL: 0 ... 600 VAC)
- X5** – AnO4: Analog Outputs
- X100** – Modbus TCP / IEC 60870-5-104 / DNP3.0 TCP/UDP, Ethernet interface, 100 Mbit/s, RJ45 (BASE100-FX)
- X102** – Universal Resistance-Temperature Detector (URTD) input, Fiber optics interface, Versatile Link
- X104** – IRIG-B00X, incl. System Contact (Supervision Contact)

# MRMV4-2A1BDA

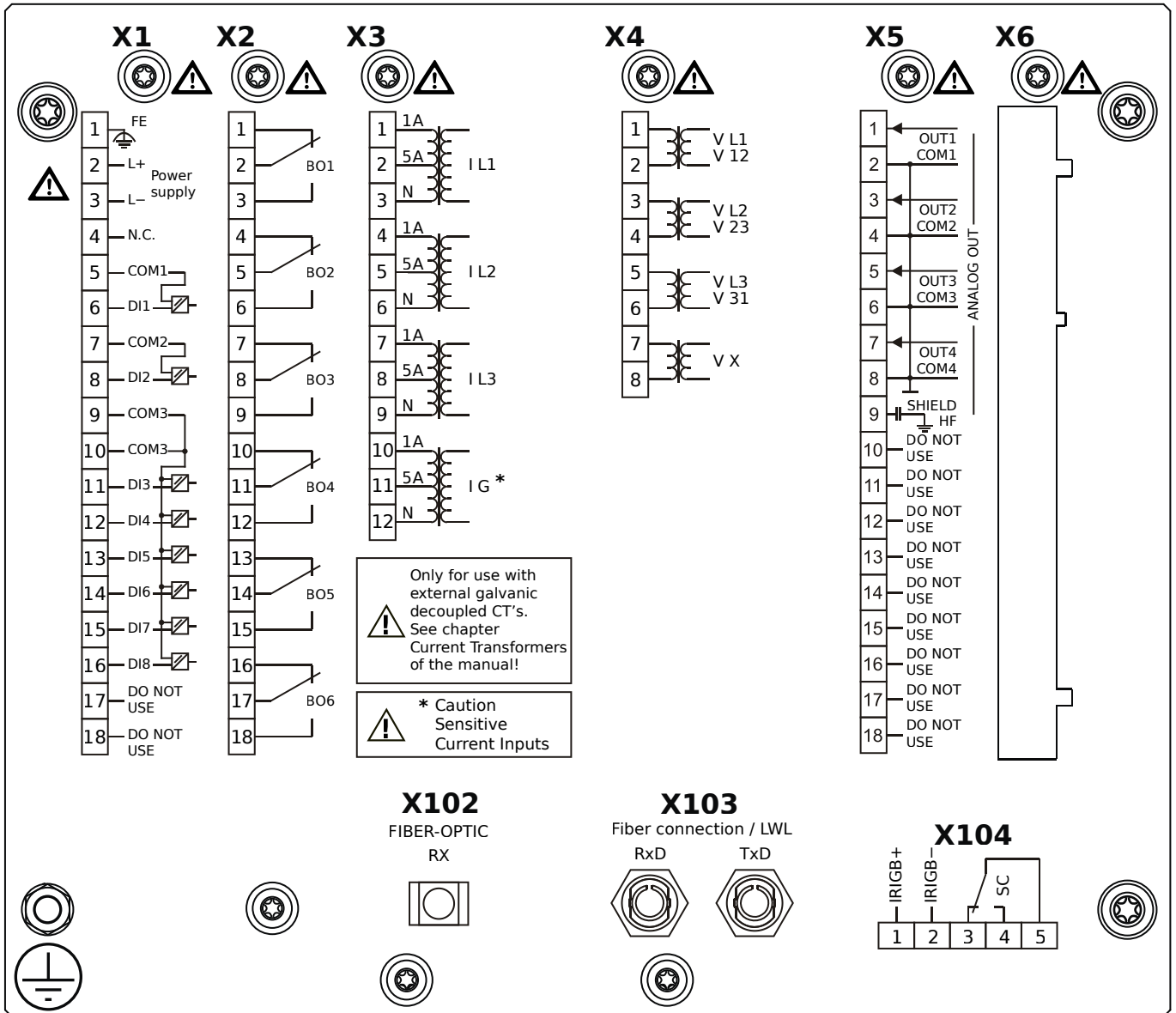

## Housing B2, small display, 19" rack mounting

- X1** – DI8-X1: Wide-range power supply unit, incl. 2 non-grouped digital inputs and 6 grouped digital inputs
- X2** – OR6: Assembly Group with 6 Output Relays (Changeover / Form C)
- X3** – TIs: Standard phase current measuring card and sensitive ground current measuring
- X4** – TU: Card with 4 voltage transformer measuring inputs (0 ... 800 VAC, under UL: 0 ... 600 VAC)
- X5** – AnO4: Analog Outputs
- X102** – Universal Resistance-Temperature Detector (URTD) input, Fiber optics interface, Versatile Link
- X103** – Profibus-DP, Fiber optics interface, ST Connector
- X104** – IRIG-B00X, incl. System Contact (Supervision Contact)



# MRMV4-2A1BDB

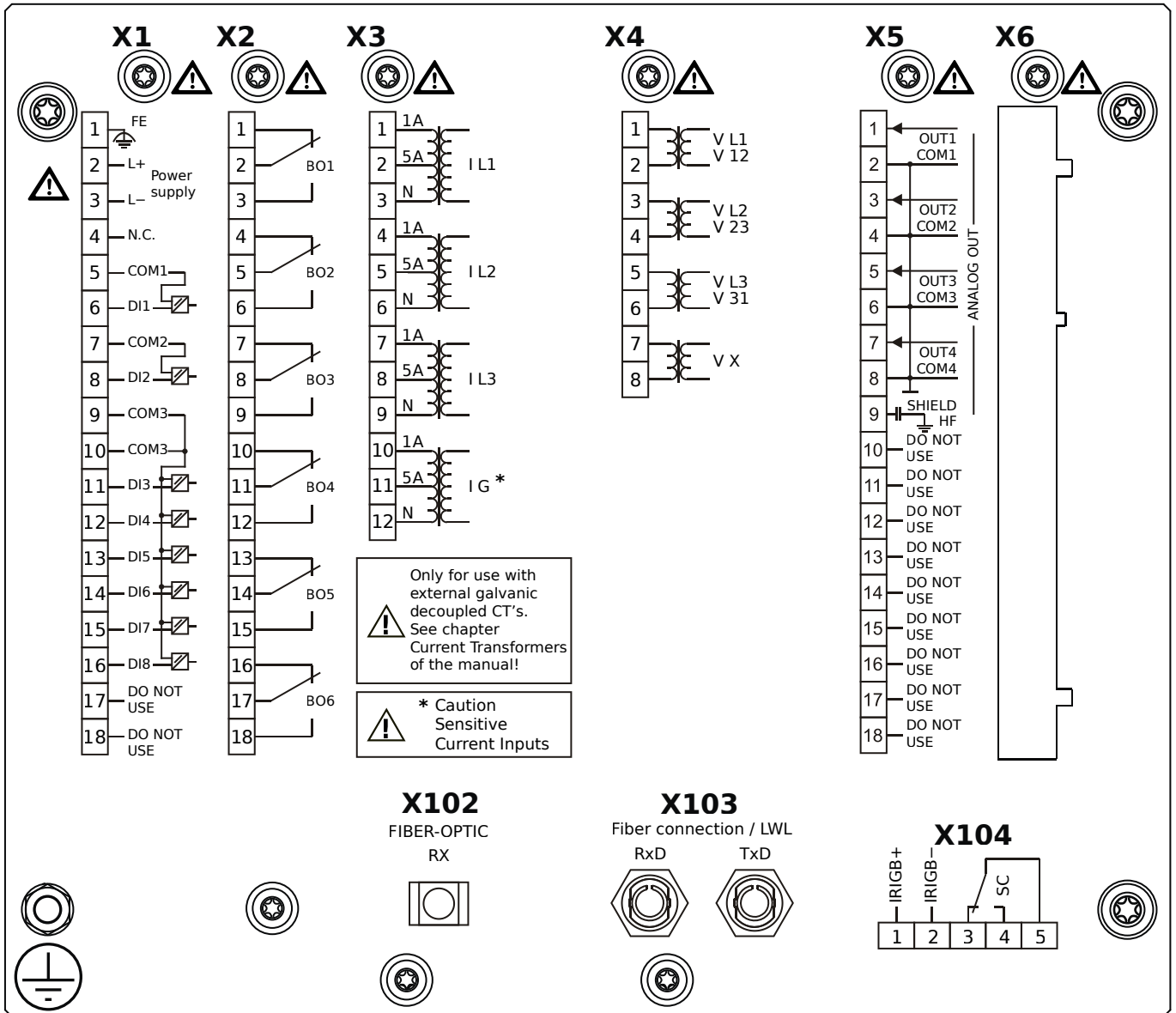

## Housing B2, small display, 19" rack mounting

+ Conformal Coating (for installations in harsh environment)

- X1** – DI8-X1: Wide-range power supply unit, incl. 2 non-grouped digital inputs and 6 grouped digital inputs
- X2** – OR6: Assembly Group with 6 Output Relays (Changeover / Form C)
- X3** – TIs: Standard phase current measuring card and sensitive ground current measuring
- X4** – TU: Card with 4 voltage transformer measuring inputs (0 ... 800 VAC, under UL: 0 ... 600 VAC)
- X5** – AnO4: Analog Outputs
- X102** – Universal Resistance-Temperature Detector (URTD) input, Fiber optics interface, Versatile Link
- X103** – Profibus-DP, Fiber optics interface, ST Connector
- X104** – IRIG-B00X, incl. System Contact (Supervision Contact)

# MRMV4-2A1BEA

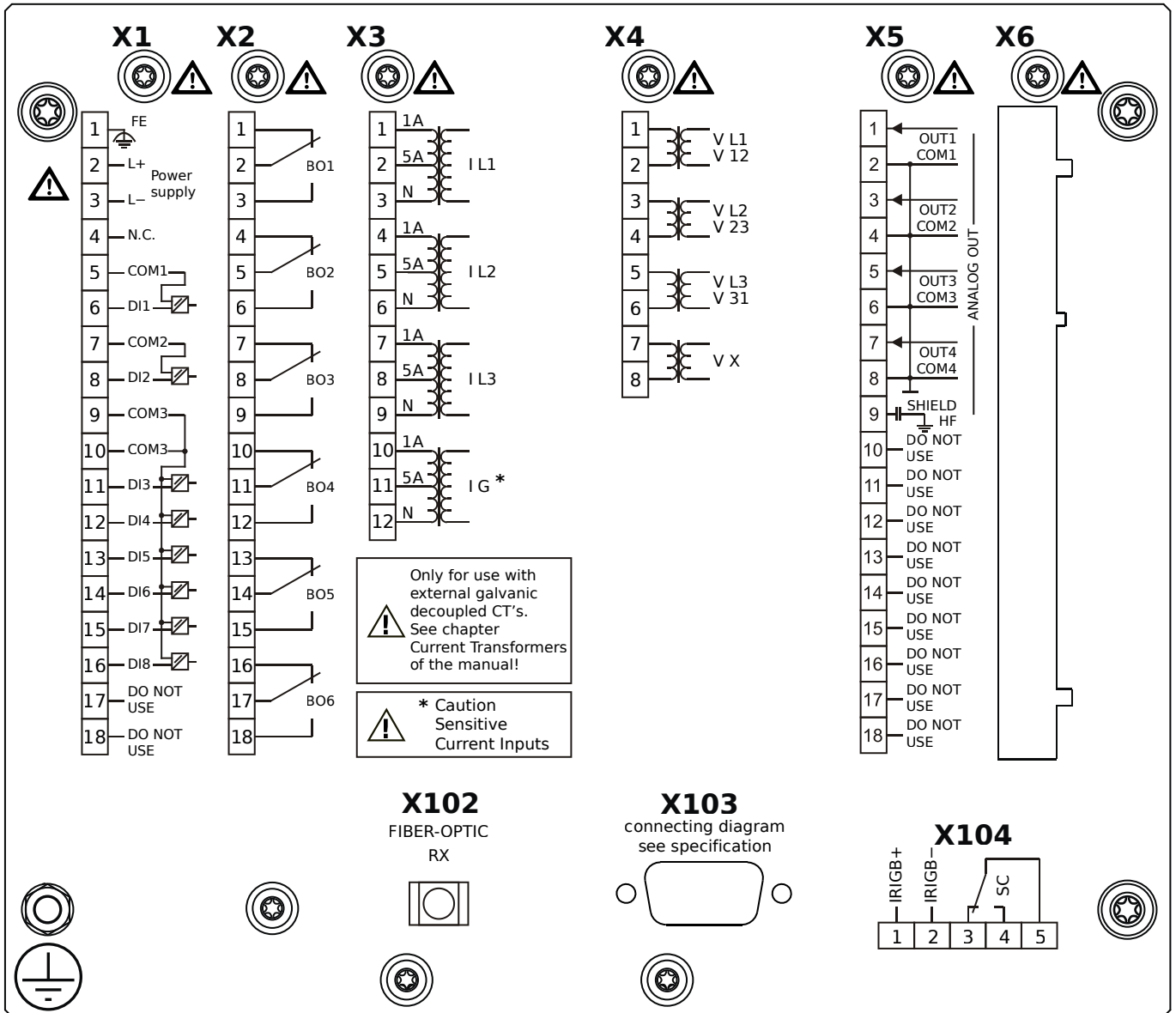

## Housing B2, small display, 19" rack mounting

- X1** – DI8-X1: Wide-range power supply unit, incl. 2 non-grouped digital inputs and 6 grouped digital inputs
- X2** – OR6: Assembly Group with 6 Output Relays (Changeover / Form C)
- X3** – TIs: Standard phase current measuring card and sensitive ground current measuring
- X4** – TU: Card with 4 voltage transformer measuring inputs (0 ... 800 VAC, under UL: 0 ... 600 VAC)
- X5** – AnO4: Analog Outputs
- X102** – Universal Resistance-Temperature Detector (URTD) input, Fiber optics interface, Versatile Link
- X103** – Profibus-DP, RS485, D-SUB
- X104** – IRIG-B00X, incl. System Contact (Supervision Contact)

# MRMV4-2A1BEB

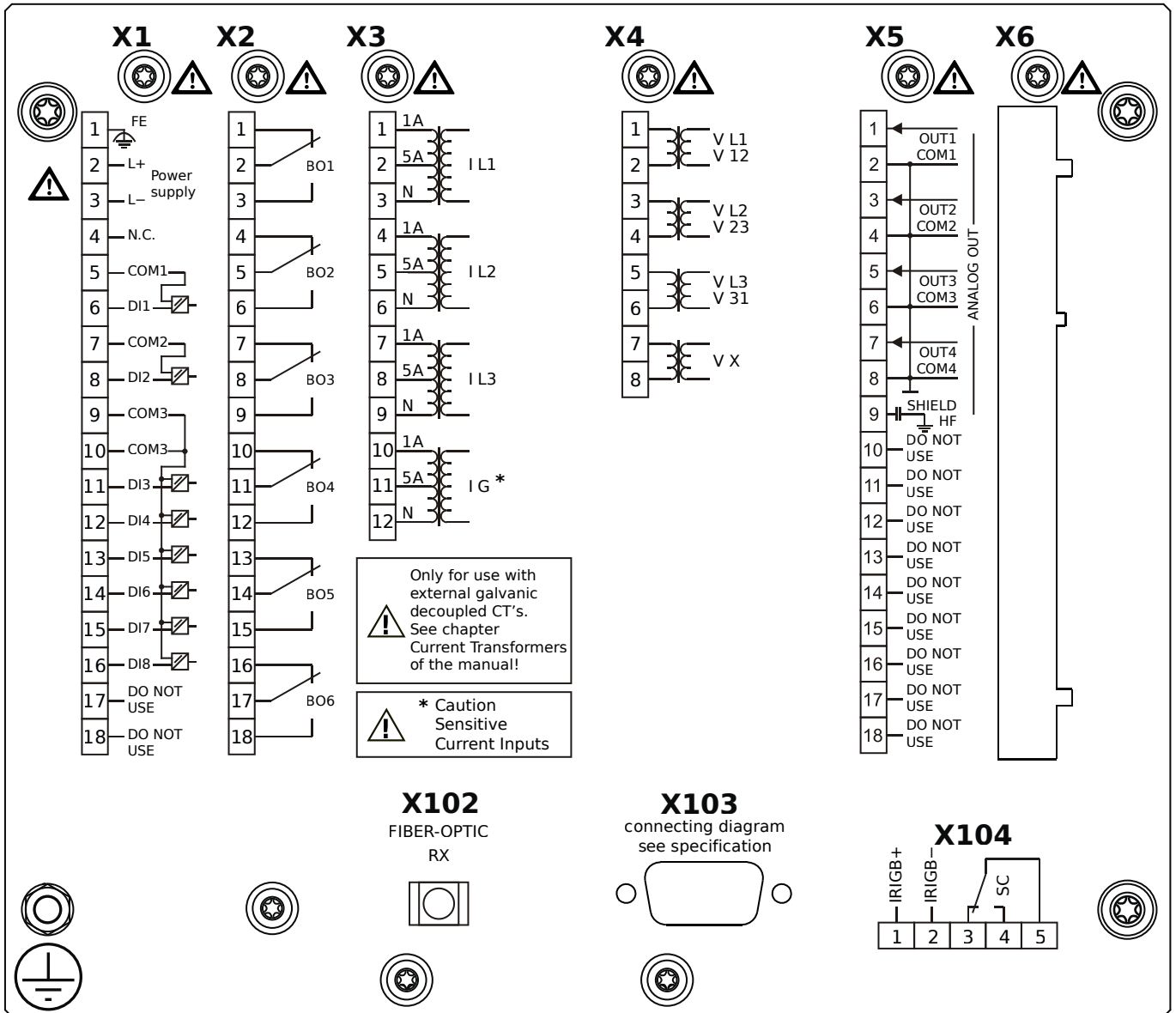

## Housing B2, small display, 19" rack mounting

+ Conformal Coating (for installations in harsh environment)

- X1** – DI8-X1: Wide-range power supply unit, incl. 2 non-grouped digital inputs and 6 grouped digital inputs
- X2** – OR6: Assembly Group with 6 Output Relays (Changeover / Form C)
- X3** – TIs: Standard phase current measuring card and sensitive ground current measuring
- X4** – TU: Card with 4 voltage transformer measuring inputs (0 ... 800 VAC, under UL: 0 ... 600 VAC)
- X5** – AnO4: Analog Outputs
- X102** – Universal Resistance-Temperature Detector (URTD) input, Fiber optics interface, Versatile Link
- X103** – Profibus-DP, RS485, D-SUB
- X104** – IRIG-B00X, incl. System Contact (Supervision Contact)

# MRMV4-2A1BFA

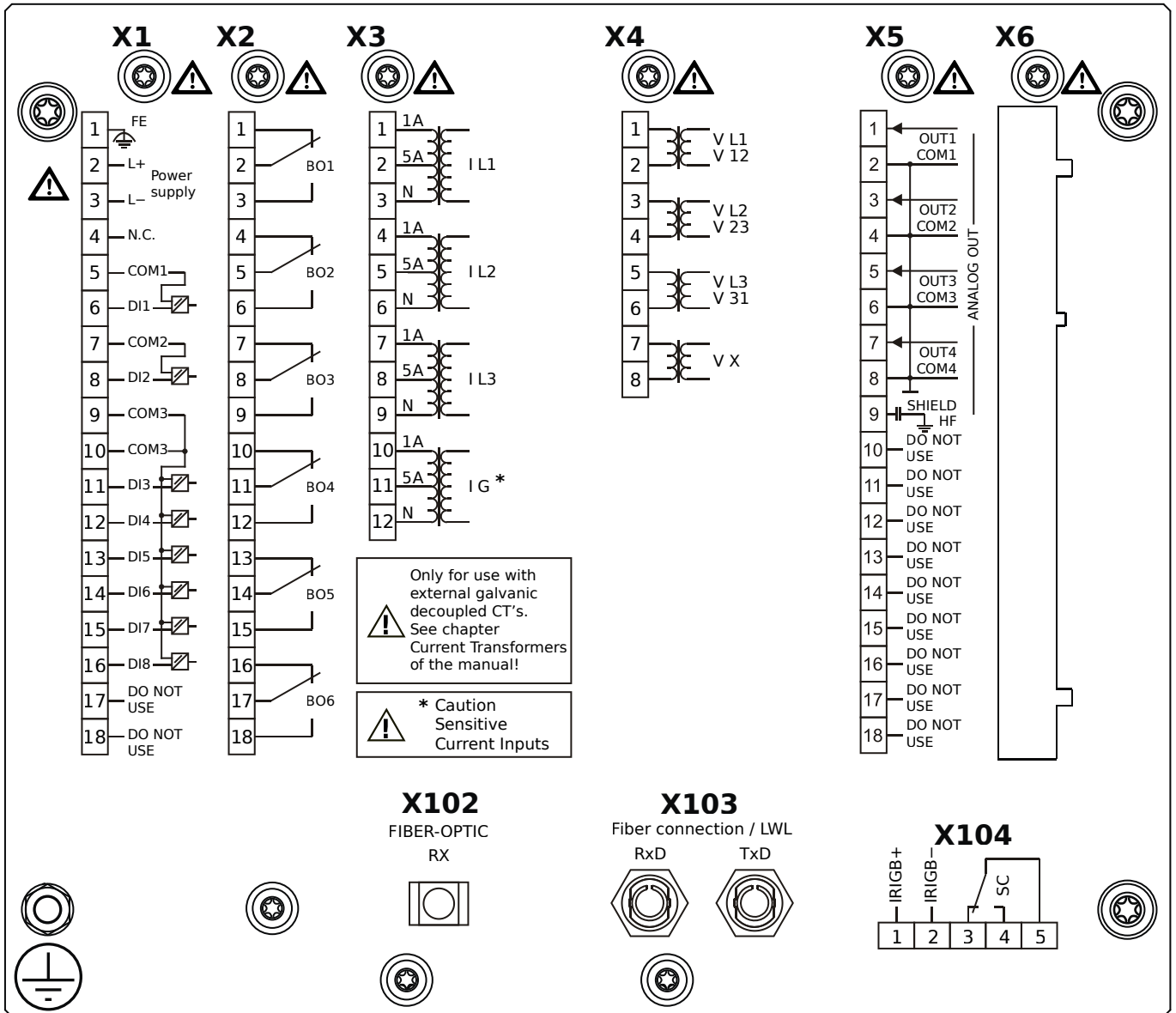

## Housing B2, small display, 19" rack mounting

- X1** – DI8-X1: Wide-range power supply unit, incl. 2 non-grouped digital inputs and 6 grouped digital inputs
- X2** – OR6: Assembly Group with 6 Output Relays (Changeover / Form C)
- X3** – TIs: Standard phase current measuring card and sensitive ground current measuring
- X4** – TU: Card with 4 voltage transformer measuring inputs (0 ... 800 VAC, under UL: 0 ... 600 VAC)
- X5** – AnO4: Analog Outputs
- X102** – Universal Resistance-Temperature Detector (URTD) input, Fiber optics interface, Versatile Link
- X103** – Modbus RTU / IEC 60870-5-103 / DNP3.0 RTU, Fiber optics interface, ST Connector
- X104** – IRIG-B00X, incl. System Contact (Supervision Contact)

# MRMV4-2A1BFB

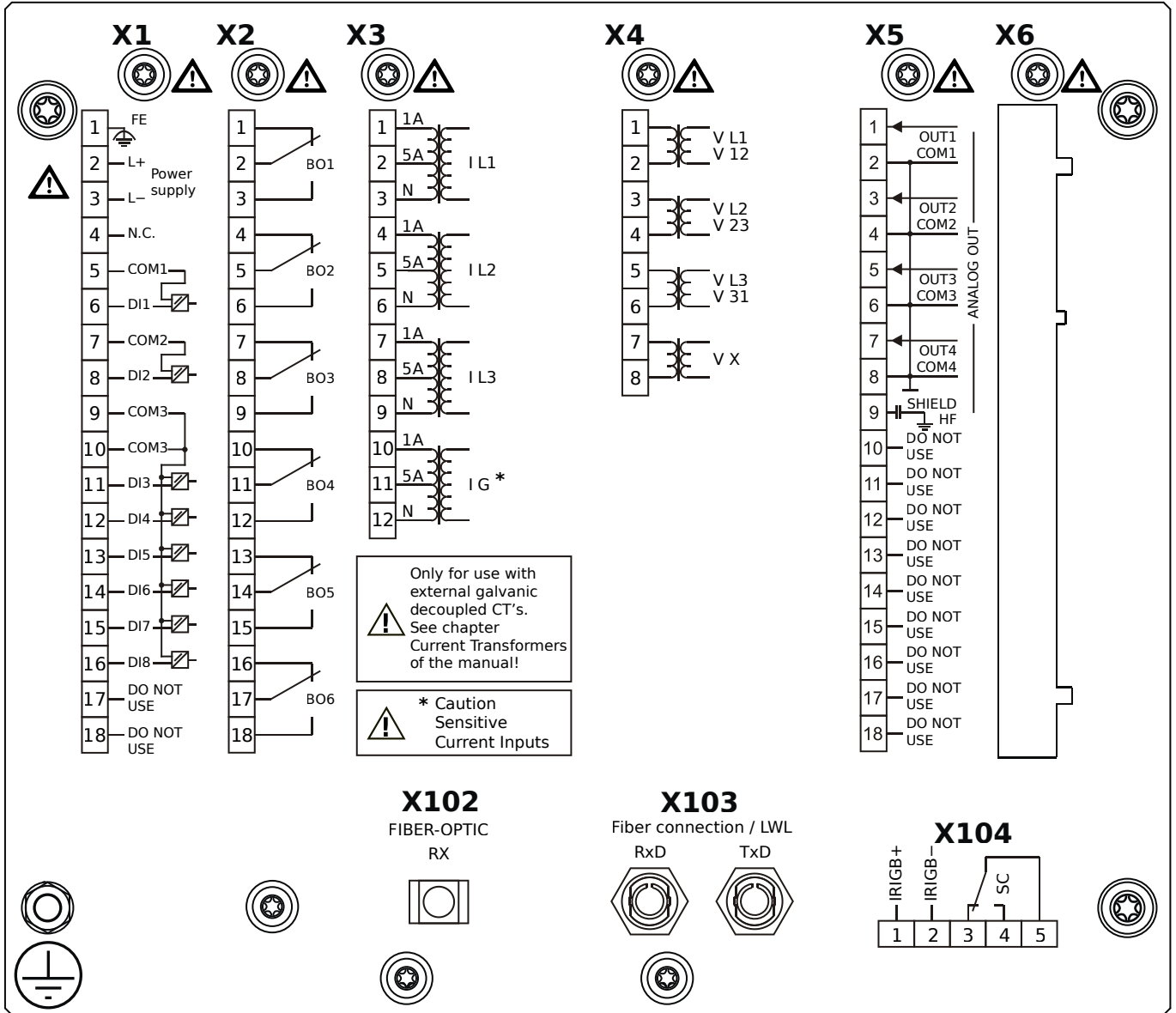

## Housing B2, small display, 19" rack mounting

+ Conformal Coating (for installations in harsh environment)

- X1** – DI8-X1: Wide-range power supply unit, incl. 2 non-grouped digital inputs and 6 grouped digital inputs
- X2** – OR6: Assembly Group with 6 Output Relays (Changeover / Form C)
- X3** – TIs: Standard phase current measuring card and sensitive ground current measuring
- X4** – TU: Card with 4 voltage transformer measuring inputs (0 ... 800 VAC, under UL: 0 ... 600 VAC)
- X5** – AnO4: Analog Outputs
- X102** – Universal Resistance-Temperature Detector (URTD) input, Fiber optics interface, Versatile Link
- X103** – Modbus RTU / IEC 60870-5-103 / DNP3.0 RTU, Fiber optics interface, ST Connector
- X104** – IRIG-B00X, incl. System Contact (Supervision Contact)

# MRMV4-2A1BGA

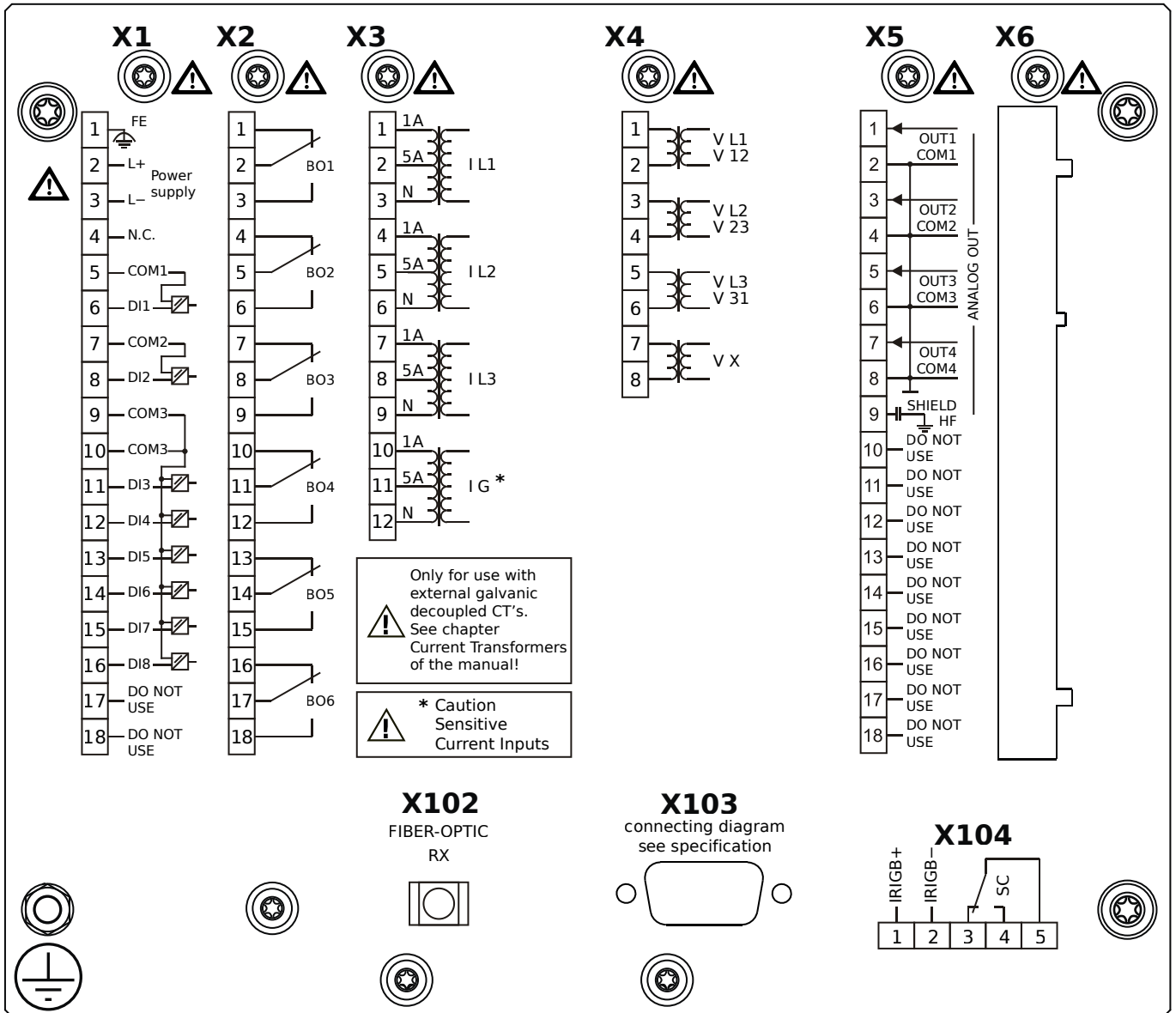

## Housing B2, small display, 19" rack mounting

- X1** – DI8-X1: Wide-range power supply unit, incl. 2 non-grouped digital inputs and 6 grouped digital inputs
- X2** – OR6: Assembly Group with 6 Output Relays (Changeover / Form C)
- X3** – TIs: Standard phase current measuring card and sensitive ground current measuring
- X4** – TU: Card with 4 voltage transformer measuring inputs (0 ... 800 VAC, under UL: 0 ... 600 VAC)
- X5** – AnO4: Analog Outputs
- X102** – Universal Resistance-Temperature Detector (URTD) input, Fiber optics interface, Versatile Link
- X103** – Modbus RTU / IEC 60870-5-103 / DNP3.0 RTU, RS485, D-SUB
- X104** – IRIG-B00X, incl. System Contact (Supervision Contact)

# MRMV4-2A1BGB

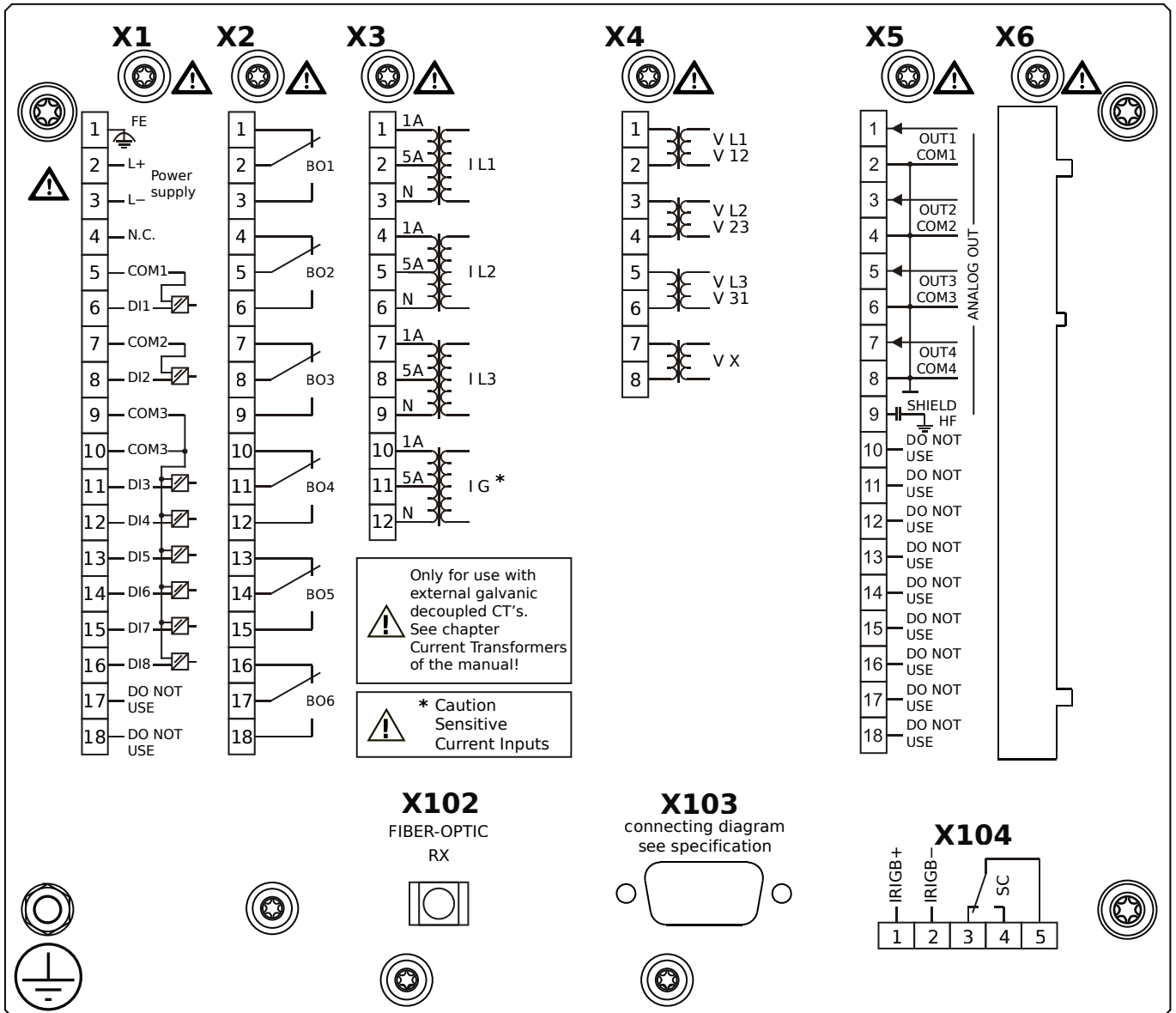

## Housing B2, small display, 19" rack mounting

+ Conformal Coating (for installations in harsh environment)

- X1** – DI8-X1: Wide-range power supply unit, incl. 2 non-grouped digital inputs and 6 grouped digital inputs
- X2** – OR6: Assembly Group with 6 Output Relays (Changeover / Form C)
- X3** – TIs: Standard phase current measuring card and sensitive ground current measuring
- X4** – TU: Card with 4 voltage transformer measuring inputs (0 ... 800 VAC, under UL: 0 ... 600 VAC)
- X5** – AnO4: Analog Outputs
- X102** – Universal Resistance-Temperature Detector (URTD) input, Fiber optics interface, Versatile Link
- X103** – Modbus RTU / IEC 60870-5-103 / DNP3.0 RTU, RS485, D-SUB
- X104** – IRIG-B00X, incl. System Contact (Supervision Contact)

# MRMV4-2A1BHA

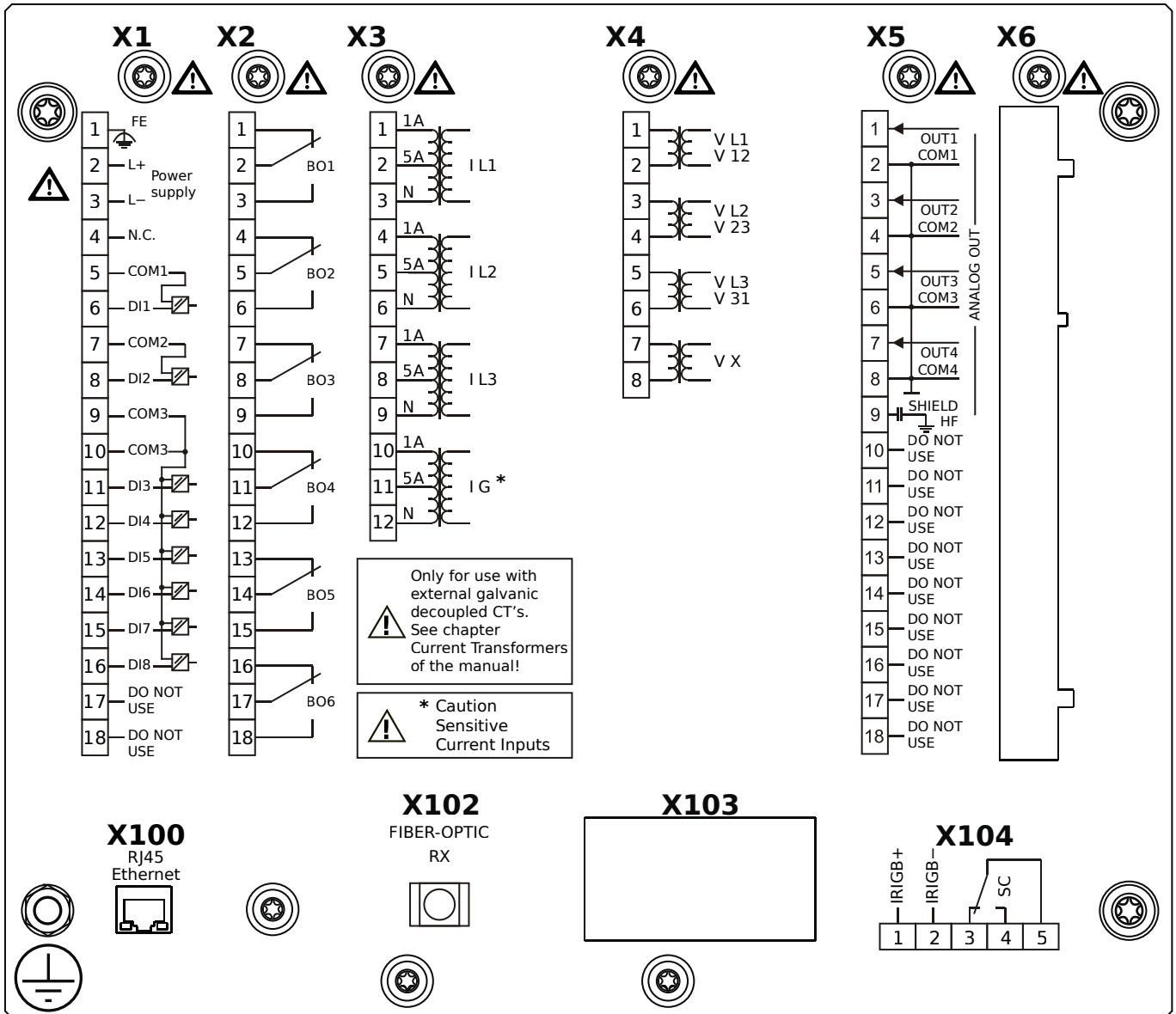

**Housing B2, small display, 19" rack mounting**

- X1** – DI8-X1: Wide-range power supply unit, incl. 2 non-grouped digital inputs and 6 grouped digital inputs
- X2** – OR6: Assembly Group with 6 Output Relays (Changeover / Form C)
- X3** – TIs: Standard phase current measuring card and sensitive ground current measuring
- X4** – TU: Card with 4 voltage transformer measuring inputs (0 ... 800 VAC, under UL: 0 ... 600 VAC)
- X5** – AnO4: Analog Outputs
- X100** – IEC 61850 / Modbus TCP / IEC 60870-5-104 / DNP3.0 TCP/UDP, Ethernet interface, 100 Mbit/s, RJ45 (BASE100-
- X102** – Universal Resistance-Temperature Detector (URTD) input, Fiber optics interface, Versatile Link
- X104** – IRIG-B00X, incl. System Contact (Supervision Contact)

FX)



# MRMV4-2A1BHB

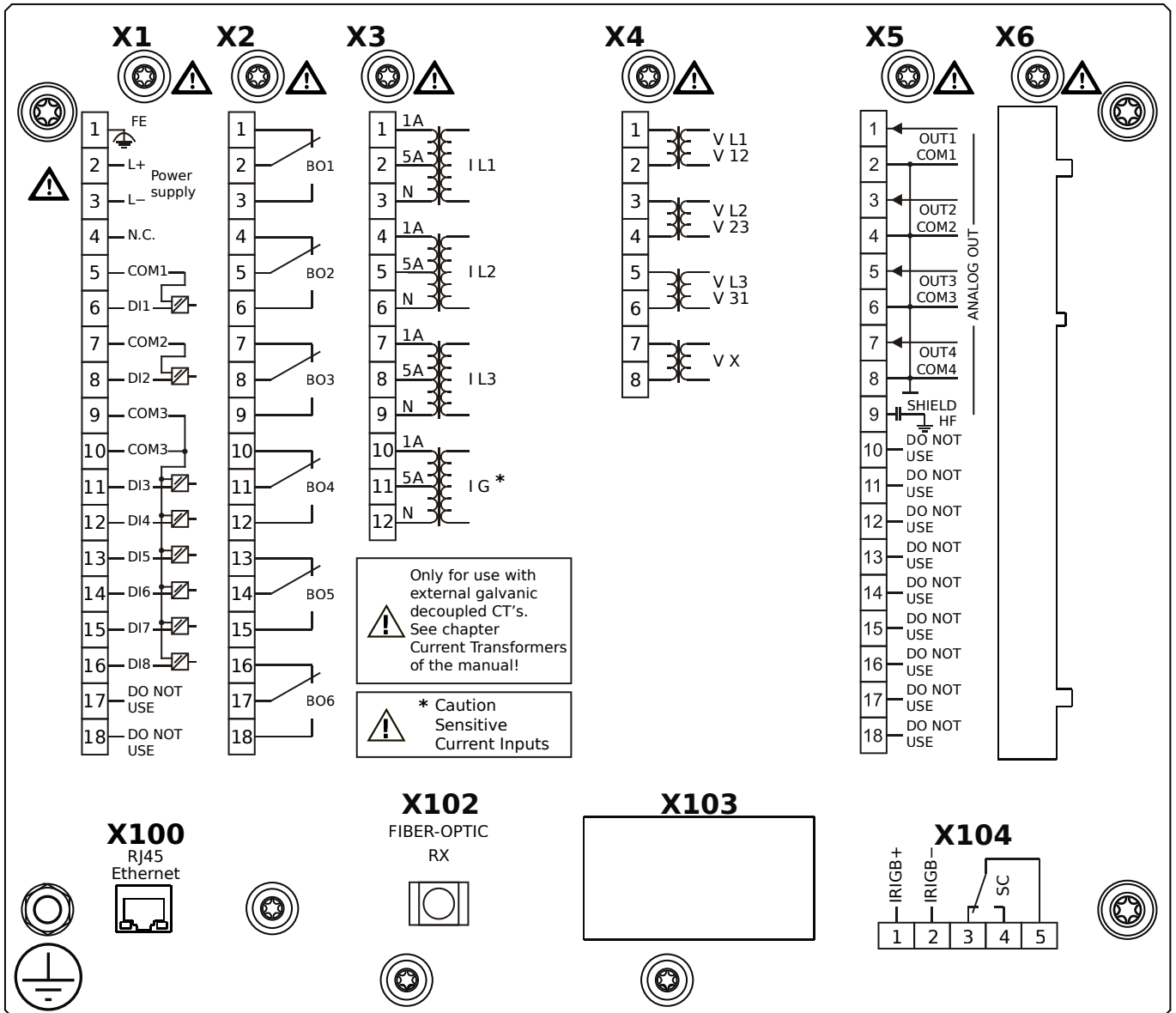

## Housing B2, small display, 19" rack mounting

+ Conformal Coating (for installations in harsh environment)

**X1** – DI8-X1: Wide-range power supply unit, incl. 2 non-grouped digital inputs and 6 grouped digital inputs

**X2** – OR6: Assembly Group with 6 Output Relays (Changeover / Form C)

**X3** – TIs: Standard phase current measuring card and sensitive ground current measuring

**X4** – TU: Card with 4 voltage transformer measuring inputs (0 ... 800 VAC, under UL: 0 ... 600 VAC)

**X5** – AnO4: Analog Outputs

**X100** – IEC 61850 / Modbus TCP / IEC 60870-5-104 / DNP3.0 TCP/UDP, Ethernet interface, 100 Mbit/s, RJ45 (BASE100-

FX)

**X102** – Universal Resistance-Temperature Detector (URTD) input, Fiber optics interface, Versatile Link

**X104** – IRIG-B00X, incl. System Contact (Supervision Contact)

# MRMV4-2A1BIA

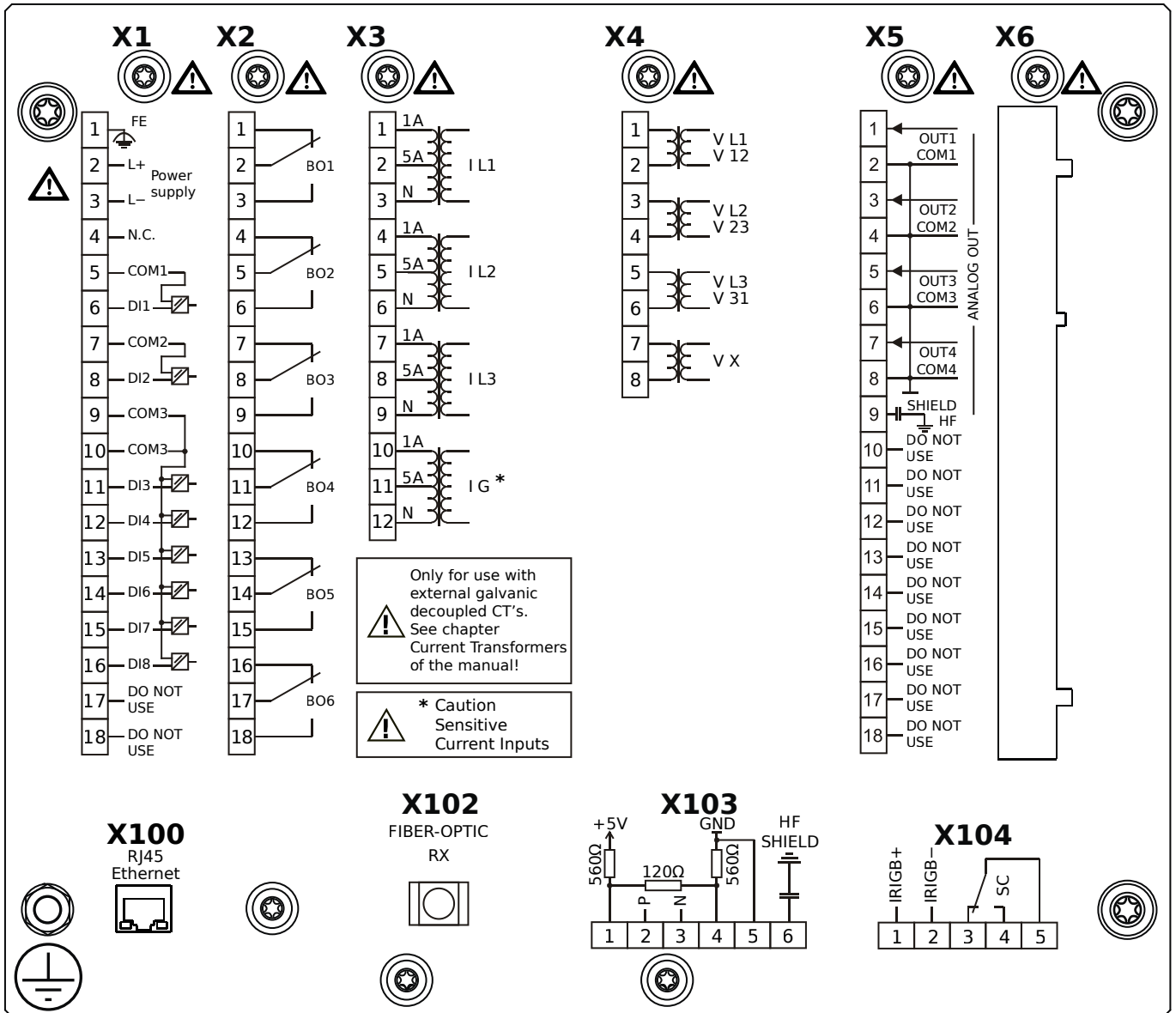

## Housing B2, small display, 19" rack mounting

- X1** – DI8-X1: Wide-range power supply unit, incl. 2 non-grouped digital inputs and 6 grouped digital inputs
- X2** – OR6: Assembly Group with 6 Output Relays (Changeover / Form C)
- X3** – TIs: Standard phase current measuring card and sensitive ground current measuring
- X4** – TU: Card with 4 voltage transformer measuring inputs (0 ... 800 VAC, under UL: 0 ... 600 VAC)
- X5** – AnO4: Analog Outputs
- X100** – Modbus TCP / IEC 60870-5-104 / DNP3.0 TCP/UDP, Ethernet interface, 100 Mbit/s, RJ45 (BASE100-FX)
- X102** – Universal Resistance-Temperature Detector (URTD) input, Fiber optics interface, Versatile Link
- X103** – IEC 60870-5-103 / Modbus RTU / DNP3.0 RTU, RS485, Terminals
- X104** – IRIG-B00X, incl. System Contact (Supervision Contact)

# MRMV4-2A1BIB

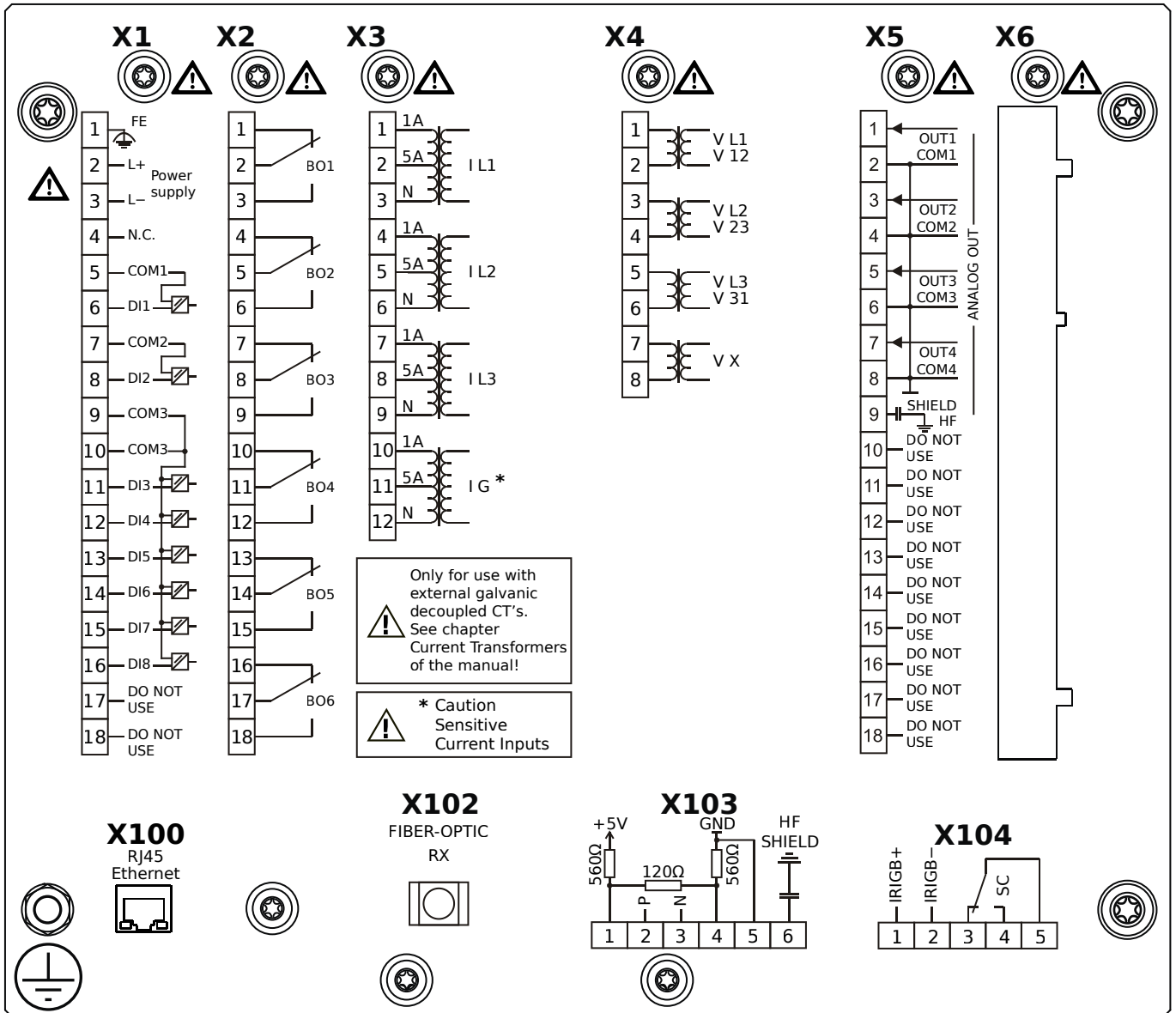

## Housing B2, small display, 19" rack mounting

+ Conformal Coating (for installations in harsh environment)

- X1** – DI8-X1: Wide-range power supply unit, incl. 2 non-grouped digital inputs and 6 grouped digital inputs
- X2** – OR6: Assembly Group with 6 Output Relays (Changeover / Form C)
- X3** – TIs: Standard phase current measuring card and sensitive ground current measuring
- X4** – TU: Card with 4 voltage transformer measuring inputs (0 ... 800 VAC, under UL: 0 ... 600 VAC)
- X5** – AnO4: Analog Outputs
- X100** – Modbus TCP / IEC 60870-5-104 / DNP3.0 TCP/UDP, Ethernet interface, 100 Mbit/s, RJ45 (BASE100-FX)
- X102** – Universal Resistance-Temperature Detector (URTD) input, Fiber optics interface, Versatile Link
- X103** – IEC 60870-5-103 / Modbus RTU / DNP3.0 RTU, RS485, Terminals
- X104** – IRIG-B00X, incl. System Contact (Supervision Contact)

# MRMV4-2A1BKA

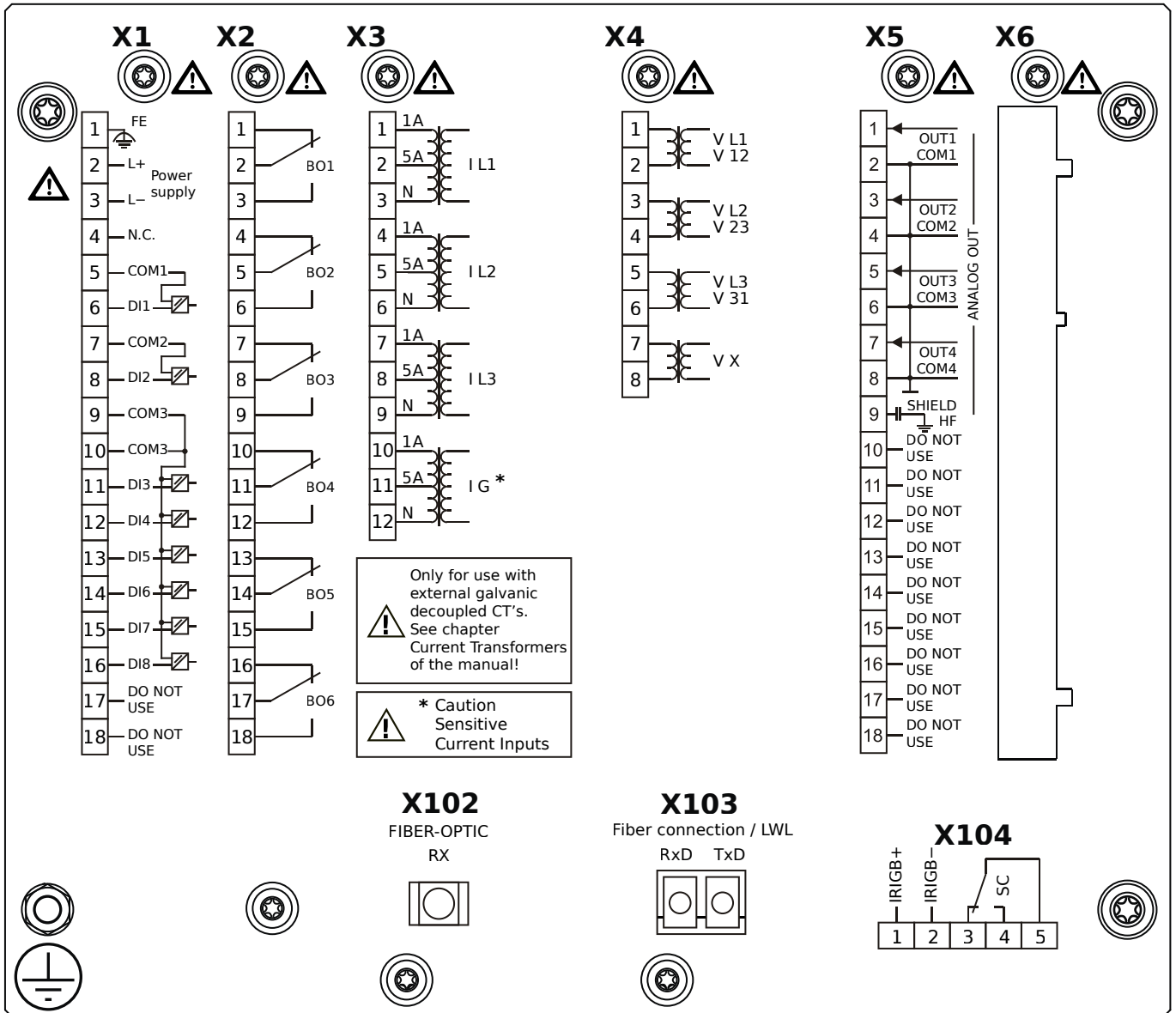

## Housing B2, small display, 19" rack mounting

- X1** – DI8-X1: Wide-range power supply unit, incl. 2 non-grouped digital inputs and 6 grouped digital inputs
- X2** – OR6: Assembly Group with 6 Output Relays (Changeover / Form C)
- X3** – TIs: Standard phase current measuring card and sensitive ground current measuring
- X4** – TU: Card with 4 voltage transformer measuring inputs (0 ... 800 VAC, under UL: 0 ... 600 VAC)
- X5** – AnO4: Analog Outputs
- X102** – Universal Resistance-Temperature Detector (URTD) input, Fiber optics interface, Versatile Link
- X103** – IEC 61850 / Modbus TCP / IEC 60870-5-104 / DNP3.0 TCP/UDP, Fiber optics interface, LC Connector
- X104** – IRIG-B00X, incl. System Contact (Supervision Contact)

# MRMV4-2A1BKB

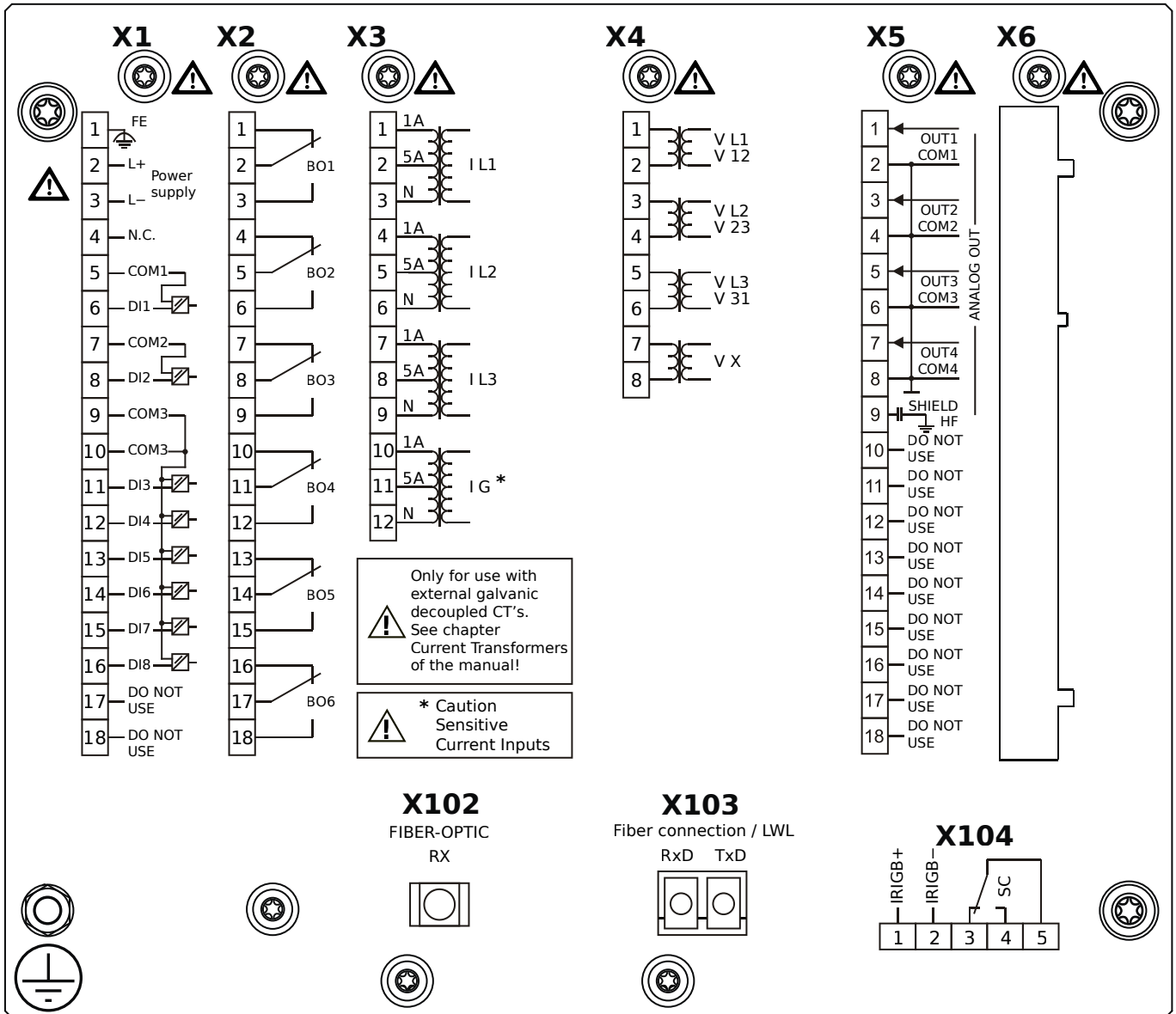

## Housing B2, small display, 19" rack mounting

+ Conformal Coating (for installations in harsh environment)

- X1** – DI8-X1: Wide-range power supply unit, incl. 2 non-grouped digital inputs and 6 grouped digital inputs
- X2** – OR6: Assembly Group with 6 Output Relays (Changeover / Form C)
- X3** – TIs: Standard phase current measuring card and sensitive ground current measuring
- X4** – TU: Card with 4 voltage transformer measuring inputs (0 ... 800 VAC, under UL: 0 ... 600 VAC)
- X5** – AnO4: Analog Outputs
- X102** – Universal Resistance-Temperature Detector (URTD) input, Fiber optics interface, Versatile Link
- X103** – IEC 61850 / Modbus TCP / IEC 60870-5-104 / DNP3.0 TCP/UDP, Fiber optics interface, LC Connector
- X104** – IRIG-B00X, incl. System Contact (Supervision Contact)

# MRMV4-2A1BLA

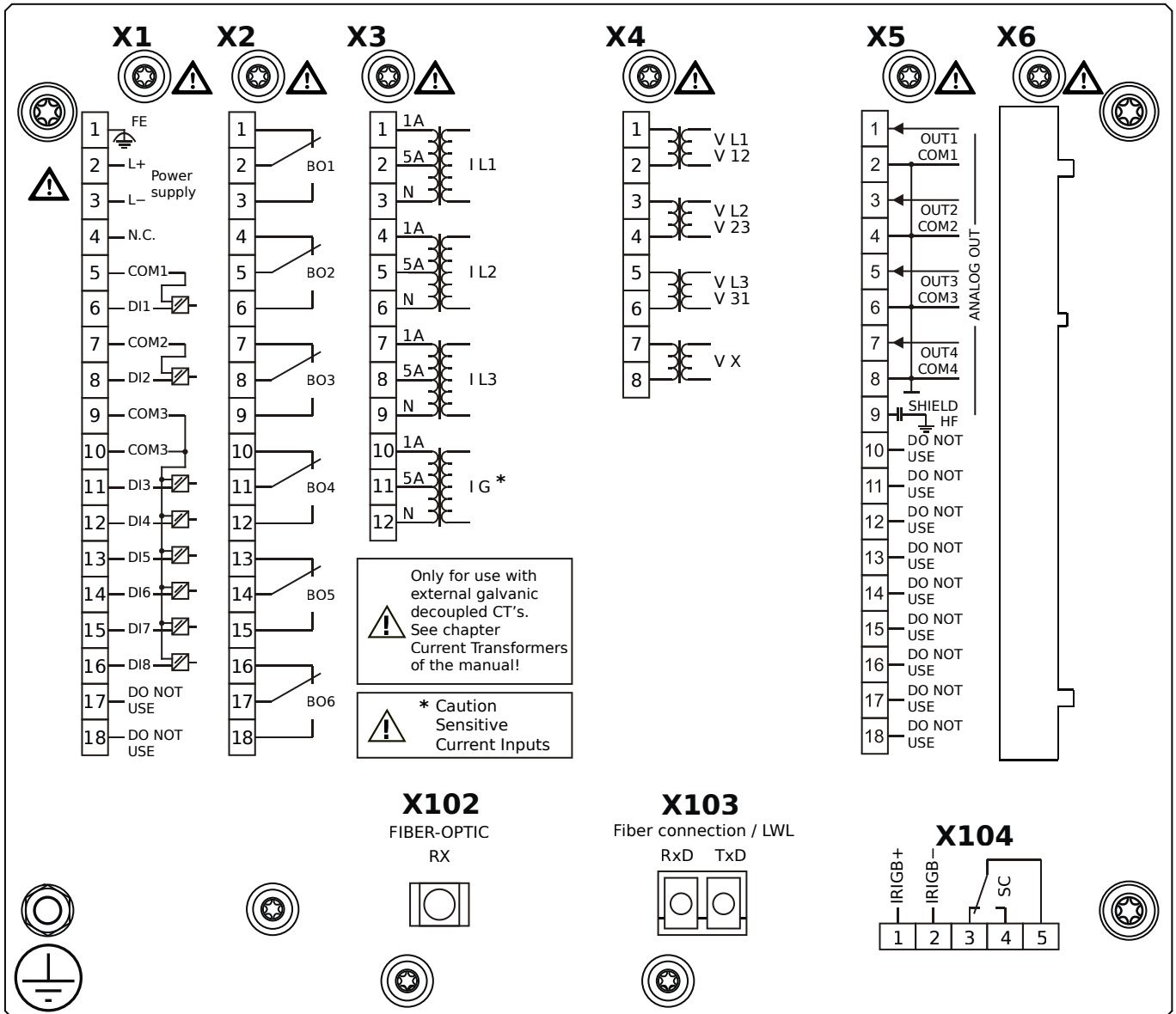

## Housing B2, small display, 19" rack mounting

- X1** – DI8-X1: Wide-range power supply unit, incl. 2 non-grouped digital inputs and 6 grouped digital inputs
- X2** – OR6: Assembly Group with 6 Output Relays (Changeover / Form C)
- X3** – TIs: Standard phase current measuring card and sensitive ground current measuring
- X4** – TU: Card with 4 voltage transformer measuring inputs (0 ... 800 VAC, under UL: 0 ... 600 VAC)
- X5** – AnO4: Analog Outputs
- X102** – Universal Resistance-Temperature Detector (URTD) input, Fiber optics interface, Versatile Link
- X103** – Modbus TCP / IEC 60870-5-104 / DNP3.0 TCP/UDP, Fiber optics interface, LC Connector
- X104** – IRIG-B00X, incl. System Contact (Supervision Contact)

# MRMV4-2A1BLB

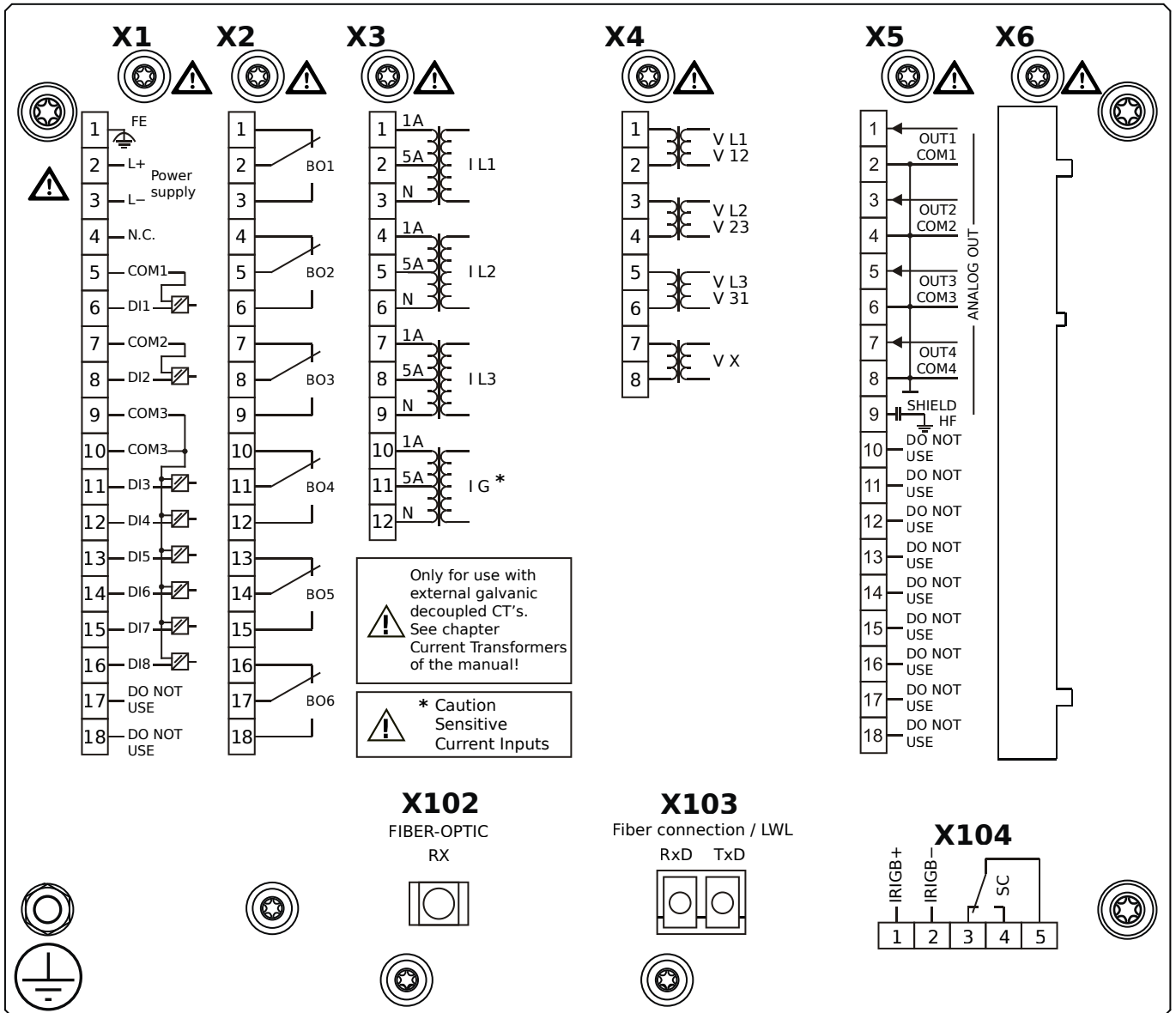

## Housing B2, small display, 19" rack mounting

+ Conformal Coating (for installations in harsh environment)

- X1** – DI8-X1: Wide-range power supply unit, incl. 2 non-grouped digital inputs and 6 grouped digital inputs
- X2** – OR6: Assembly Group with 6 Output Relays (Changeover / Form C)
- X3** – TIs: Standard phase current measuring card and sensitive ground current measuring
- X4** – TU: Card with 4 voltage transformer measuring inputs (0 ... 800 VAC, under UL: 0 ... 600 VAC)
- X5** – AnO4: Analog Outputs
- X102** – Universal Resistance-Temperature Detector (URTD) input, Fiber optics interface, Versatile Link
- X103** – Modbus TCP / IEC 60870-5-104 / DNP3.0 TCP/UDP, Fiber optics interface, LC Connector
- X104** – IRIG-B00X, incl. System Contact (Supervision Contact)

# MRMV4-2A1BOA

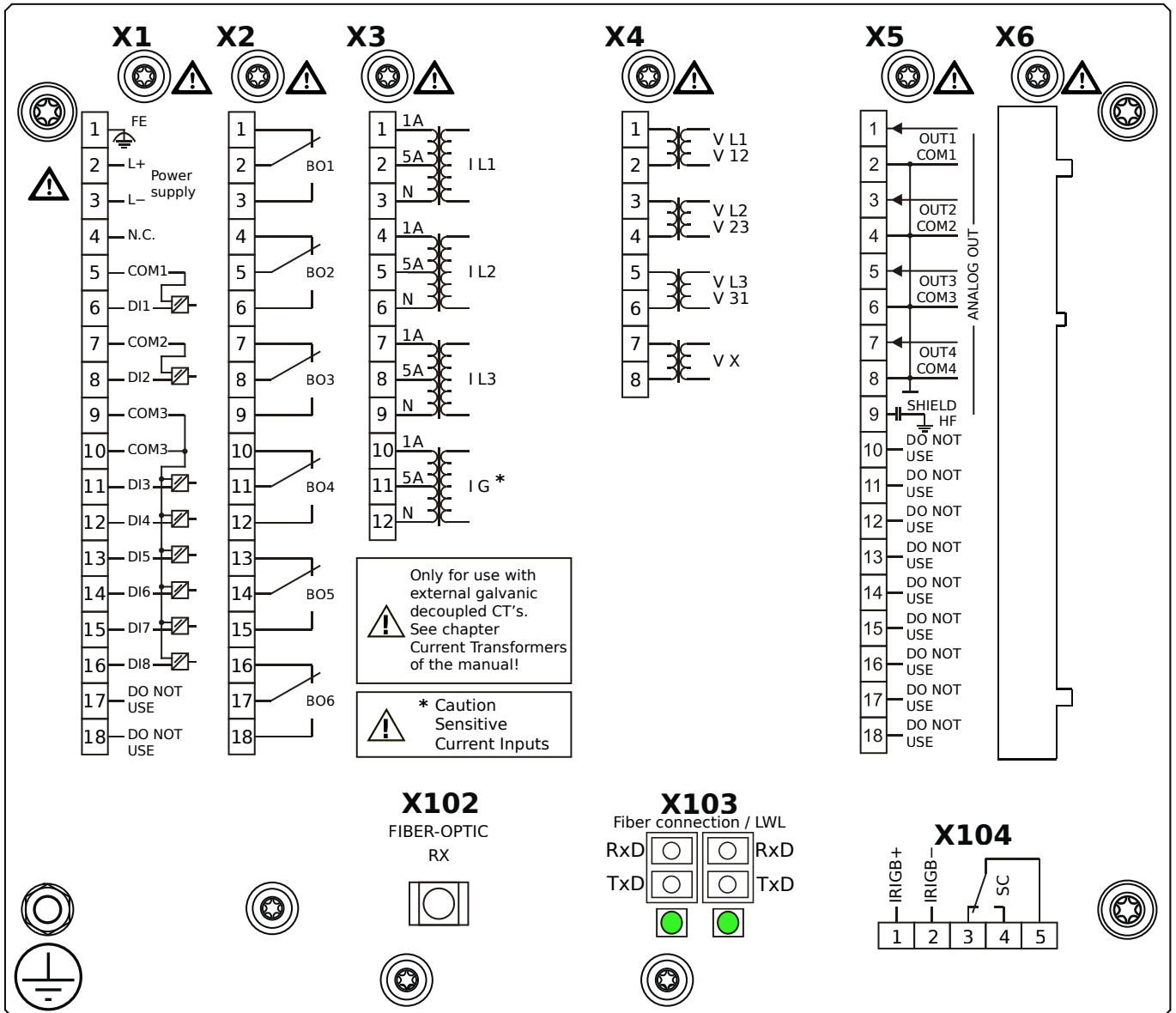

## Housing B2, small display, 19" rack mounting

- X1** – DI8-X1: Wide-range power supply unit, incl. 2 non-grouped digital inputs and 6 grouped digital inputs
- X2** – OR6: Assembly Group with 6 Output Relays (Changeover / Form C)
- X3** – TIs: Standard phase current measuring card and sensitive ground current measuring
- X4** – TU: Card with 4 voltage transformer measuring inputs (0 ... 800 VAC, under UL: 0 ... 600 VAC)
- X5** – AnO4: Analog Outputs
- X102** – Universal Resistance-Temperature Detector (URTD) input, Fiber optics interface, Versatile Link
- X103** – Modbus TCP / IEC 60870-5-104 / DNP3.0 TCP/UDP, Redundant Fiber optics interface, LC Connector
- X104** – IRIG-B00X, incl. System Contact (Supervision Contact)



# MRMV4-2A1BOB

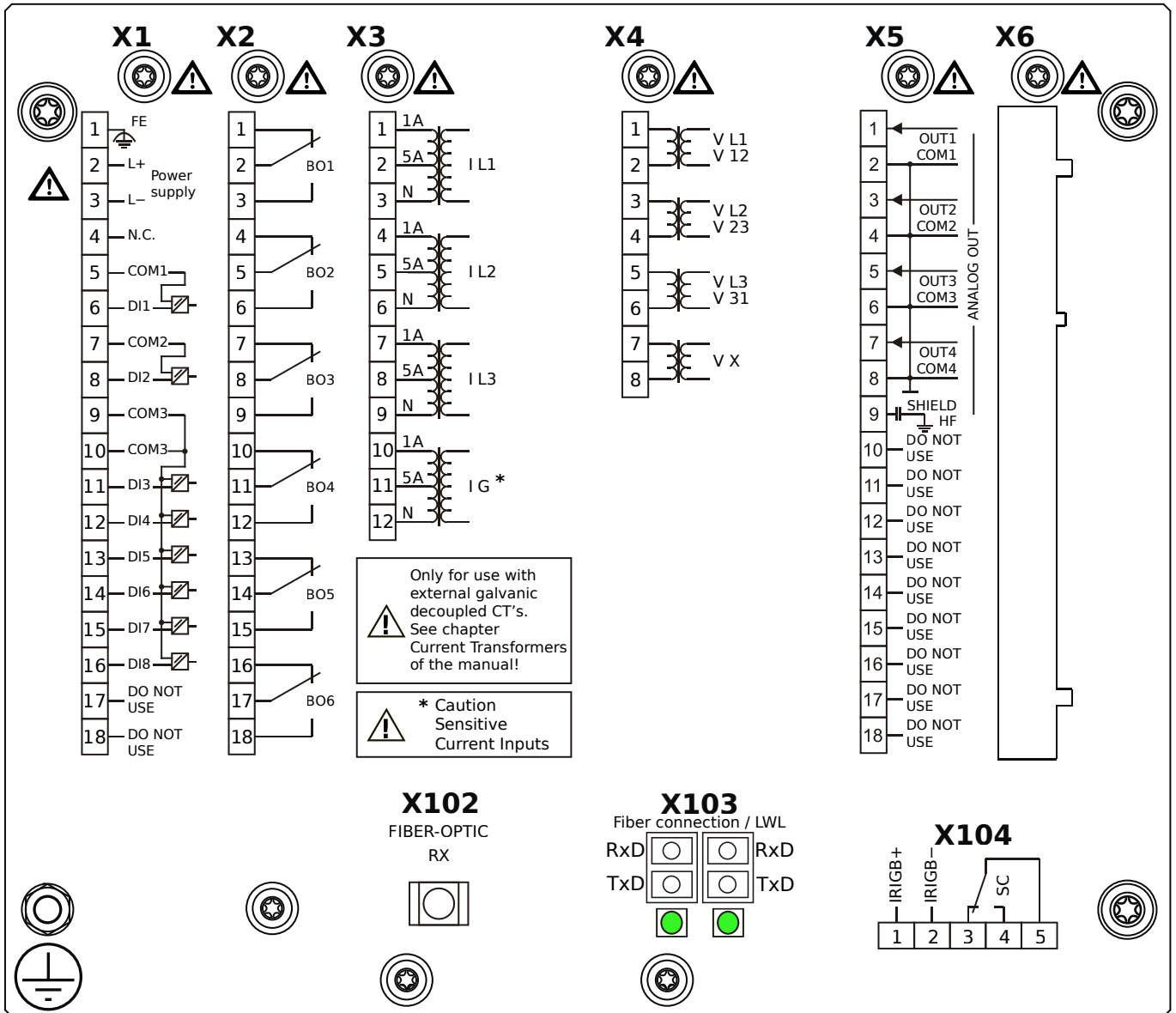

## Housing B2, small display, 19" rack mounting

+ Conformal Coating (for installations in harsh environment)

- X1** – DI8-X1: Wide-range power supply unit, incl. 2 non-grouped digital inputs and 6 grouped digital inputs
- X2** – OR6: Assembly Group with 6 Output Relays (Changeover / Form C)
- X3** – TIs: Standard phase current measuring card and sensitive ground current measuring
- X4** – TU: Card with 4 voltage transformer measuring inputs (0 ... 800 VAC, under UL: 0 ... 600 VAC)
- X5** – AnO4: Analog Outputs
- X102** – Universal Resistance-Temperature Detector (URTD) input, Fiber optics interface, Versatile Link
- X103** – Modbus TCP / IEC 60870-5-104 / DNP3.0 TCP/UDP, Redundant Fiber optics interface, LC Connector
- X104** – IRIG-B00X, incl. System Contact (Supervision Contact)

# MRMV4-2A1BPA

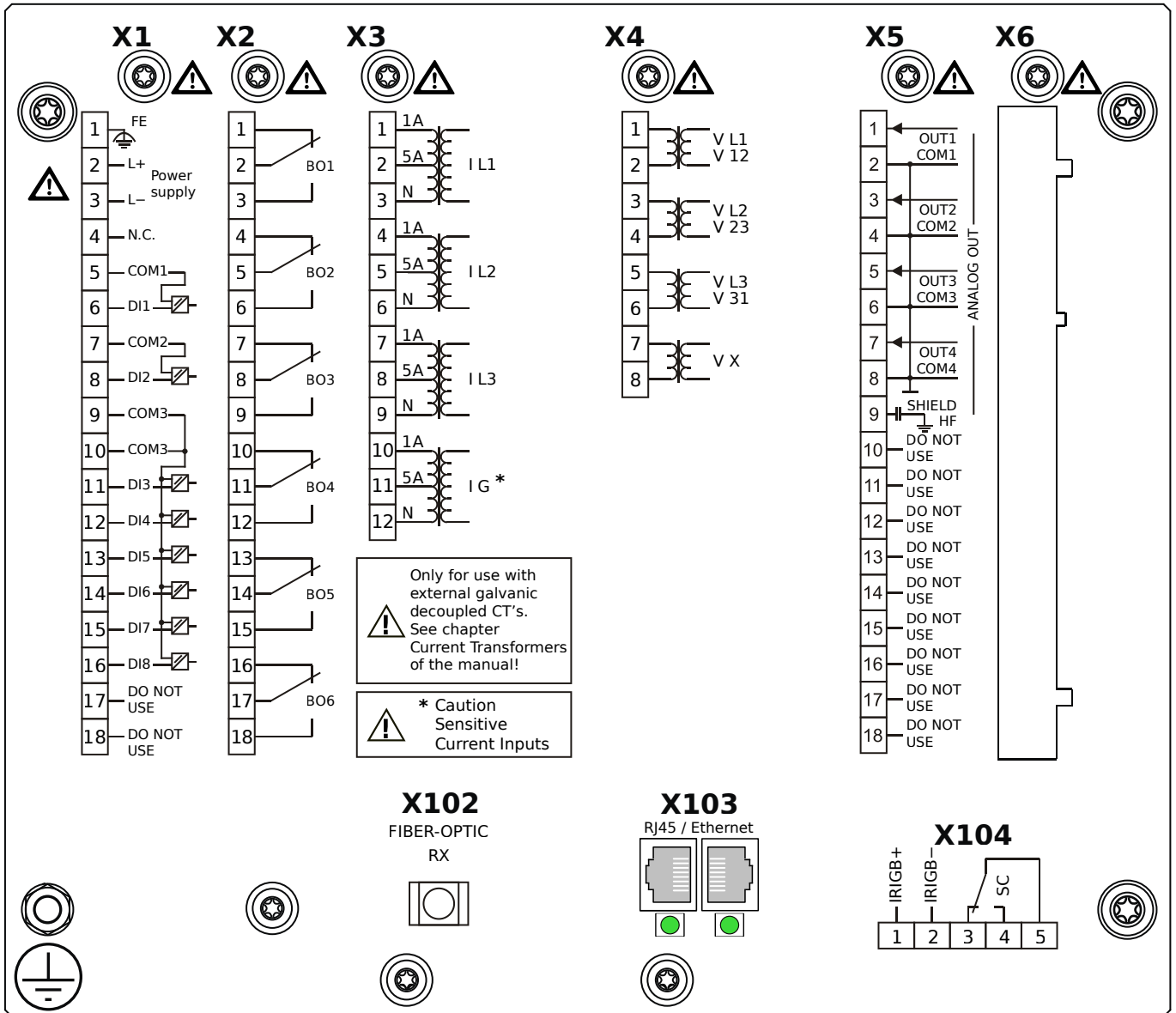

## Housing B2, small display, 19" rack mounting

- X1** – DI8-X1: Wide-range power supply unit, incl. 2 non-grouped digital inputs and 6 grouped digital inputs
- X2** – OR6: Assembly Group with 6 Output Relays (Changeover / Form C)
- X3** – TIs: Standard phase current measuring card and sensitive ground current measuring
- X4** – TU: Card with 4 voltage transformer measuring inputs (0 ... 800 VAC, under UL: 0 ... 600 VAC)
- X5** – AnO4: Analog Outputs
- X102** – Universal Resistance-Temperature Detector (URTD) input, Fiber optics interface, Versatile Link
- X103** – Modbus TCP / IEC 60870-5-104 / DNP3.0 TCP/UDP, Redundant Ethernet interface, 100 Mbit/s, RJ45 (BASE100-FX)
- X104** – IRIG-B00X, incl. System Contact (Supervision Contact)

# MRMV4-2A1BPB

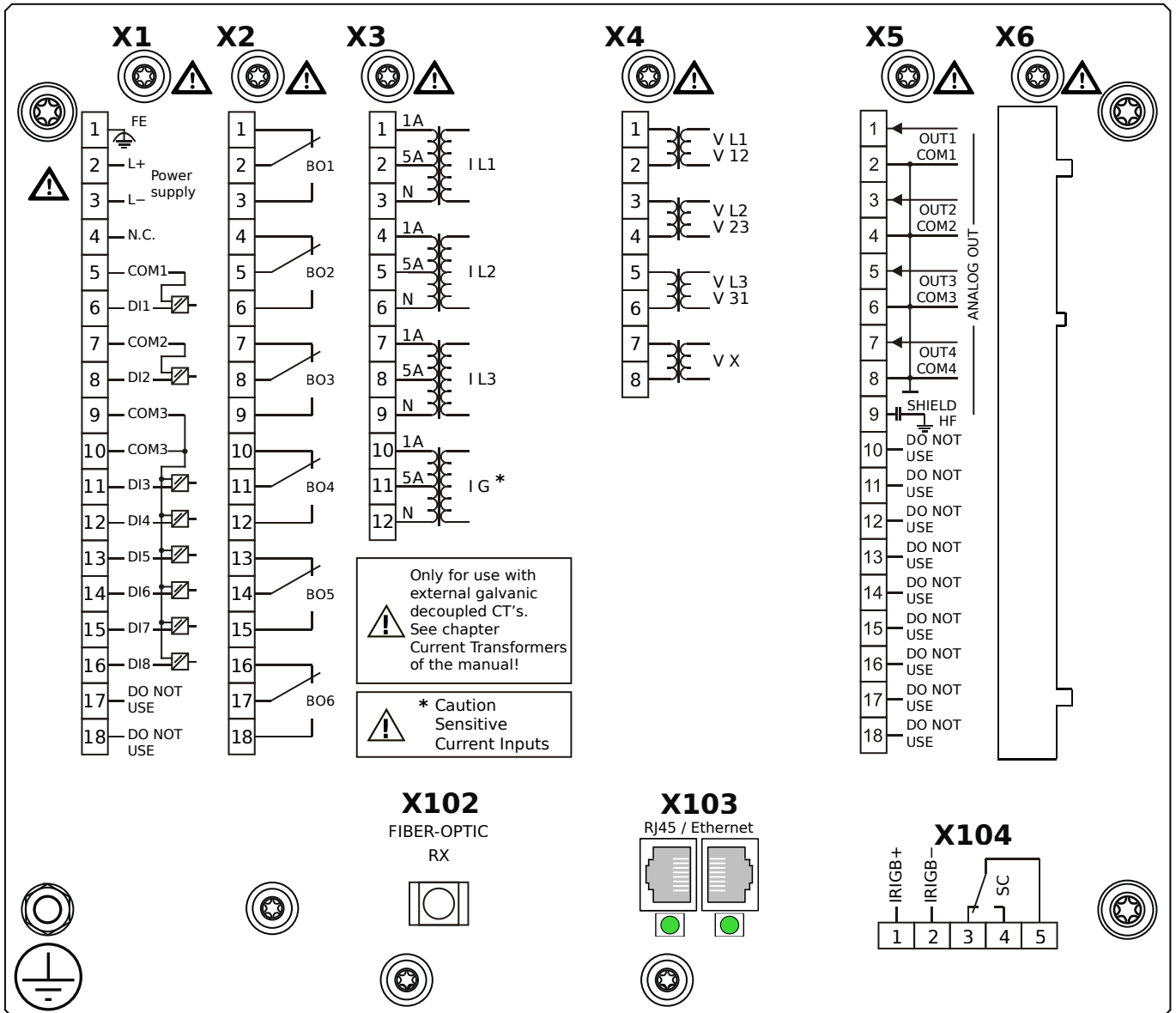

## Housing B2, small display, 19" rack mounting

+ Conformal Coating (for installations in harsh environment)

**X1** – DI8-X1: Wide-range power supply unit, incl. 2 non-grouped digital inputs and 6 grouped digital inputs

**X2** – OR6: Assembly Group with 6 Output Relays (Changeover / Form C)

**X3** – TIs: Standard phase current measuring card and sensitive ground current measuring

**X4** – TU: Card with 4 voltage transformer measuring inputs (0 ... 800 VAC, under UL: 0 ... 600 VAC)

**X5** – AnO4: Analog Outputs

**X102** – Universal Resistance-Temperature Detector (URTD) input, Fiber optics interface, Versatile Link

**X103** – Modbus TCP / IEC 60870-5-104 / DNP3.0 TCP/UDP, Redundant Ethernet interface, 100 Mbit/s, RJ45 (BASE100-FX)

**X104** – IRIG-B00X, incl. System Contact (Supervision Contact)

# MRMV4-2A1BQA

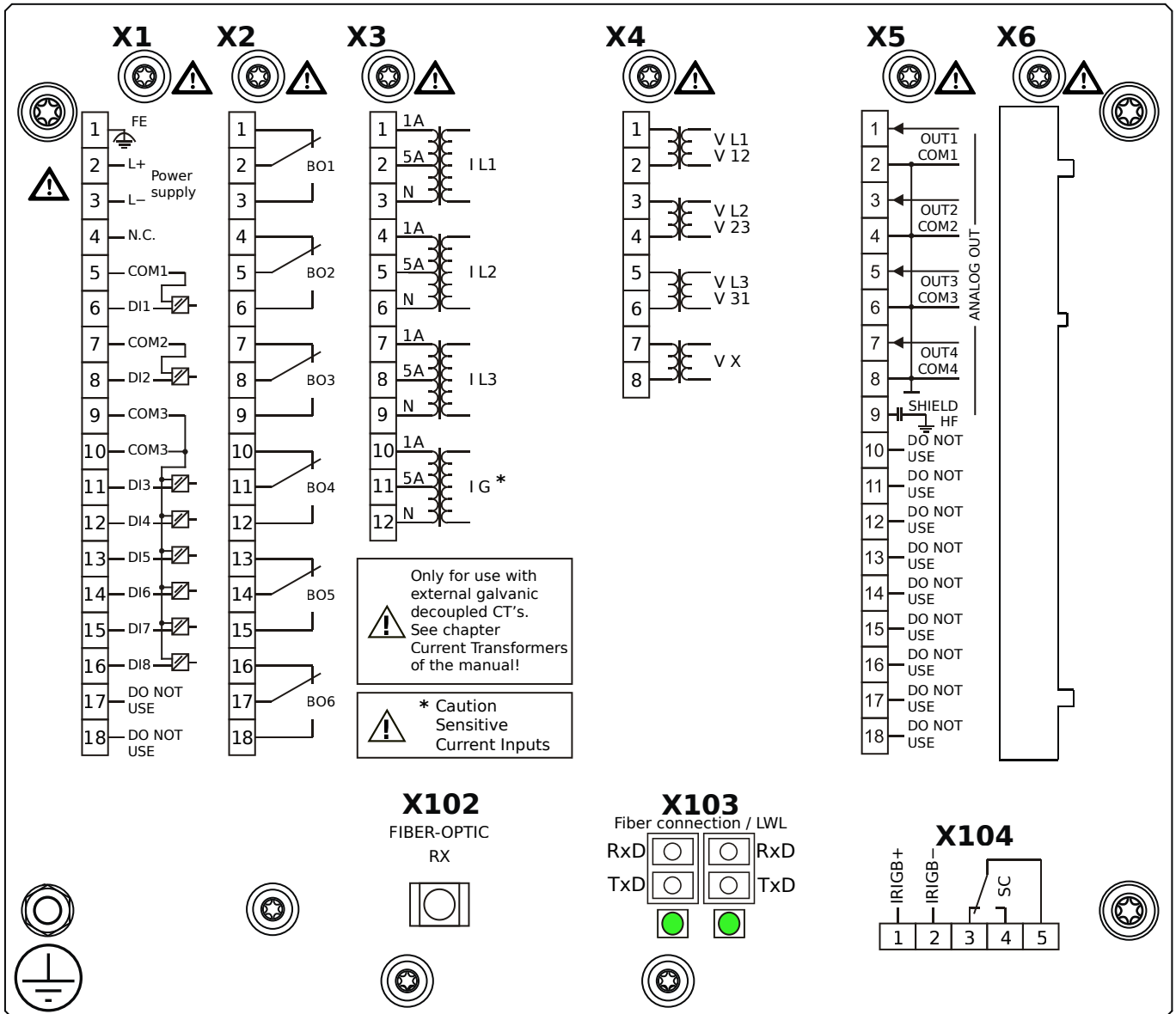

## Housing B2, small display, 19" rack mounting

- X1** – DI8-X1: Wide-range power supply unit, incl. 2 non-grouped digital inputs and 6 grouped digital inputs
- X2** – OR6: Assembly Group with 6 Output Relays (Changeover / Form C)
- X3** – TIs: Standard phase current measuring card and sensitive ground current measuring
- X4** – TU: Card with 4 voltage transformer measuring inputs (0 ... 800 VAC, under UL: 0 ... 600 VAC)
- X5** – AnO4: Analog Outputs
- X102** – Universal Resistance-Temperature Detector (URTD) input, Fiber optics interface, Versatile Link
- X103** – IEC 61850 / Modbus TCP / IEC 60870-5-104 / DNP3.0 TCP/UDP, Redundant Fiber optics interface, LC Connector
- X104** – IRIG-B00X, incl. System Contact (Supervision Contact)

# MRMV4-2A1BQB

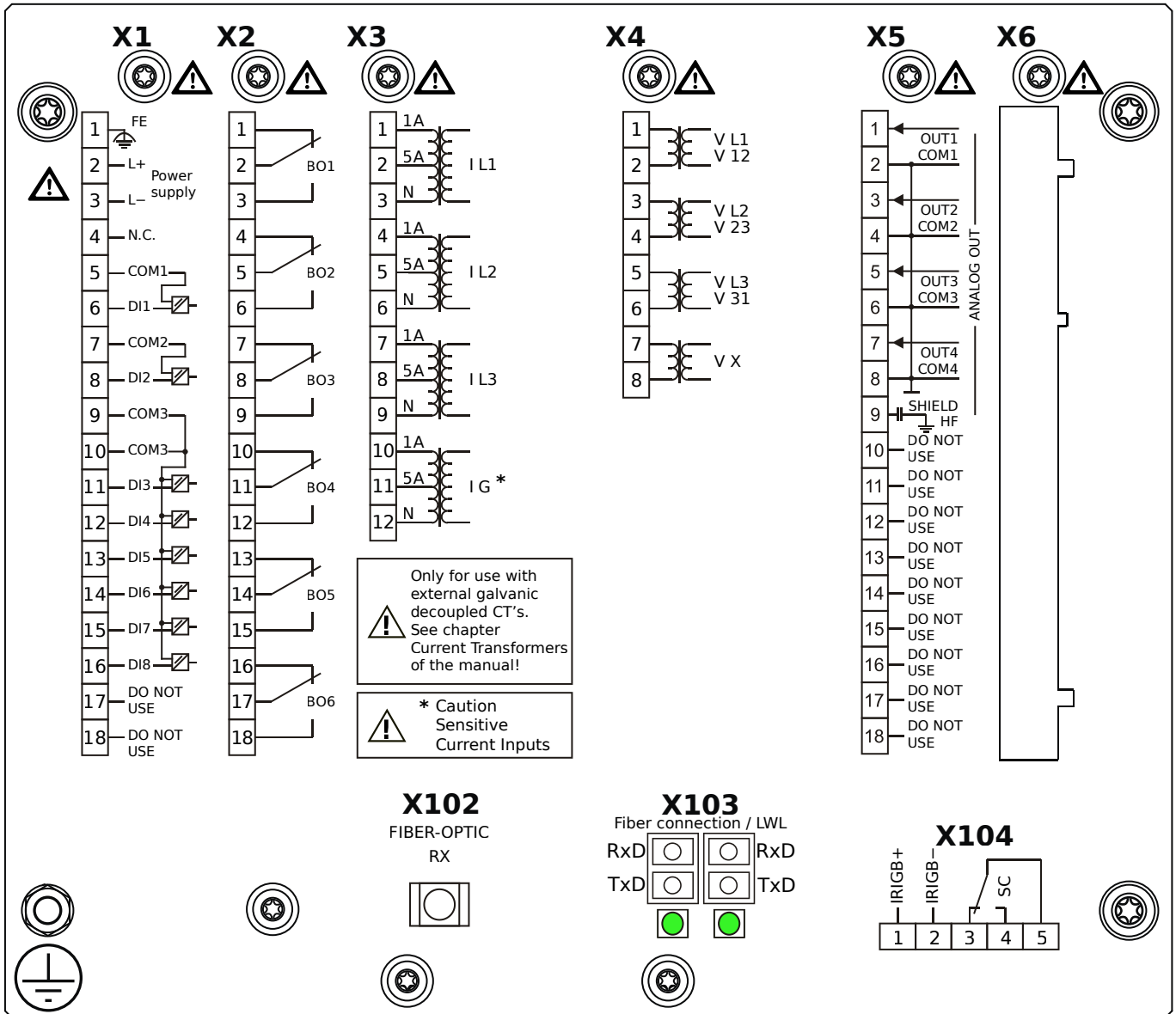

## Housing B2, small display, 19" rack mounting

+ Conformal Coating (for installations in harsh environment)

- X1** – DI8-X1: Wide-range power supply unit, incl. 2 non-grouped digital inputs and 6 grouped digital inputs
- X2** – OR6: Assembly Group with 6 Output Relays (Changeover / Form C)
- X3** – TIs: Standard phase current measuring card and sensitive ground current measuring
- X4** – TU: Card with 4 voltage transformer measuring inputs (0 ... 800 VAC, under UL: 0 ... 600 VAC)
- X5** – AnO4: Analog Outputs
- X102** – Universal Resistance-Temperature Detector (URTD) input, Fiber optics interface, Versatile Link
- X103** – IEC 61850 / Modbus TCP / IEC 60870-5-104 / DNP3.0 TCP/UDP, Redundant Fiber optics interface, LC Connector
- X104** – IRIG-B00X, incl. System Contact (Supervision Contact)

# MRMV4-2A1BRA

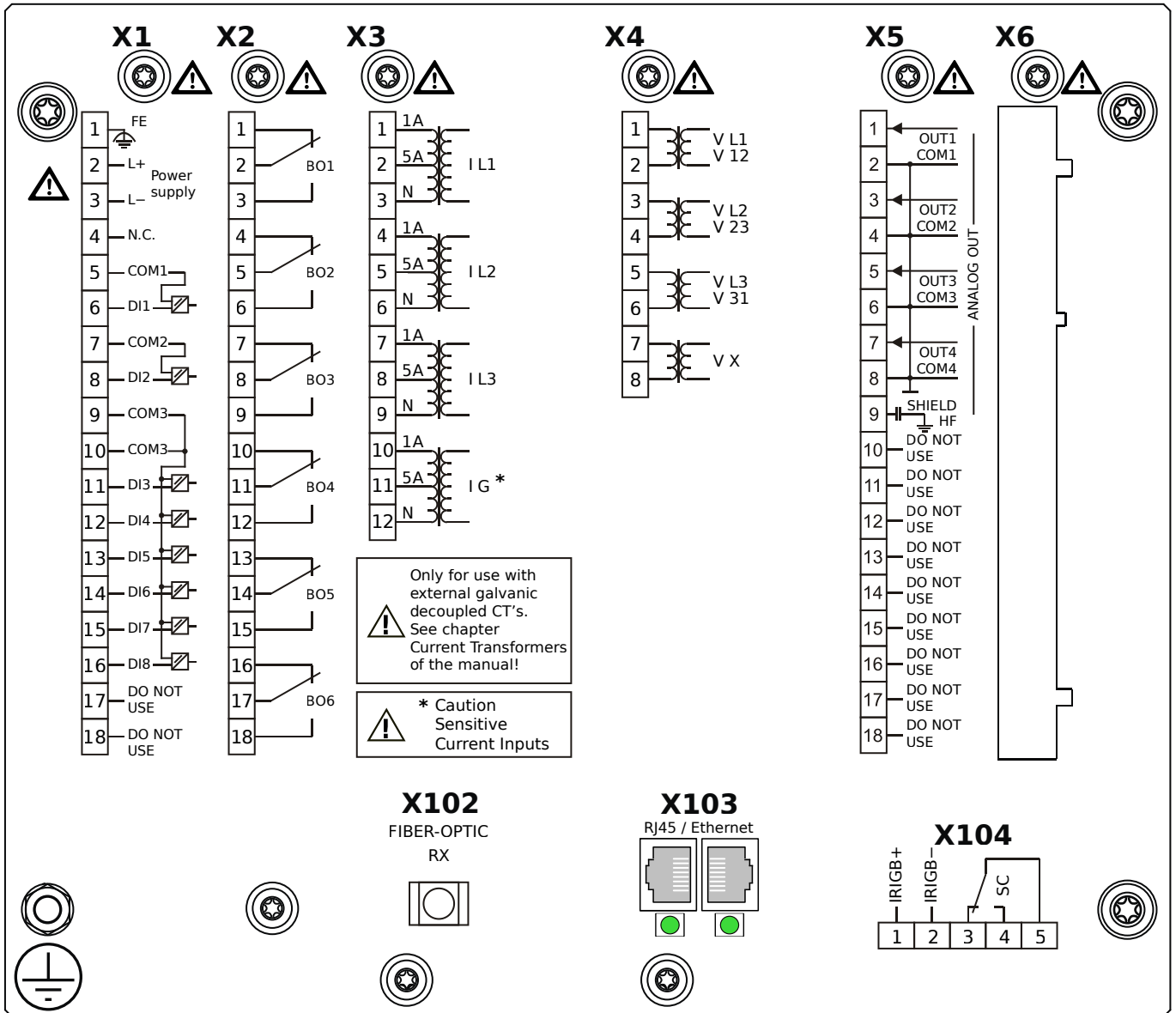

## Housing B2, small display, 19" rack mounting

**X1** – DI8-X1: Wide-range power supply unit, incl. 2 non-grouped digital inputs and 6 grouped digital inputs

**X2** – OR6: Assembly Group with 6 Output Relays (Changeover / Form C)

**X3** – TIs: Standard phase current measuring card and sensitive ground current measuring

**X4** – TU: Card with 4 voltage transformer measuring inputs (0 ... 800 VAC, under UL: 0 ... 600 VAC)

**X5** – AnO4: Analog Outputs

**X102** – Universal Resistance-Temperature Detector (URTD) input, Fiber optics interface, Versatile Link

**X103** – IEC 61850 / Modbus TCP / IEC 60870-5-104 / DNP3.0 TCP/UDP, Redundant Ethernet interface, 100 Mbit/s, RJ45

(BASE100-FX)

**X104** – IRIG-B00X, incl. System Contact (Supervision Contact)

# MRMV4-2A1BRB

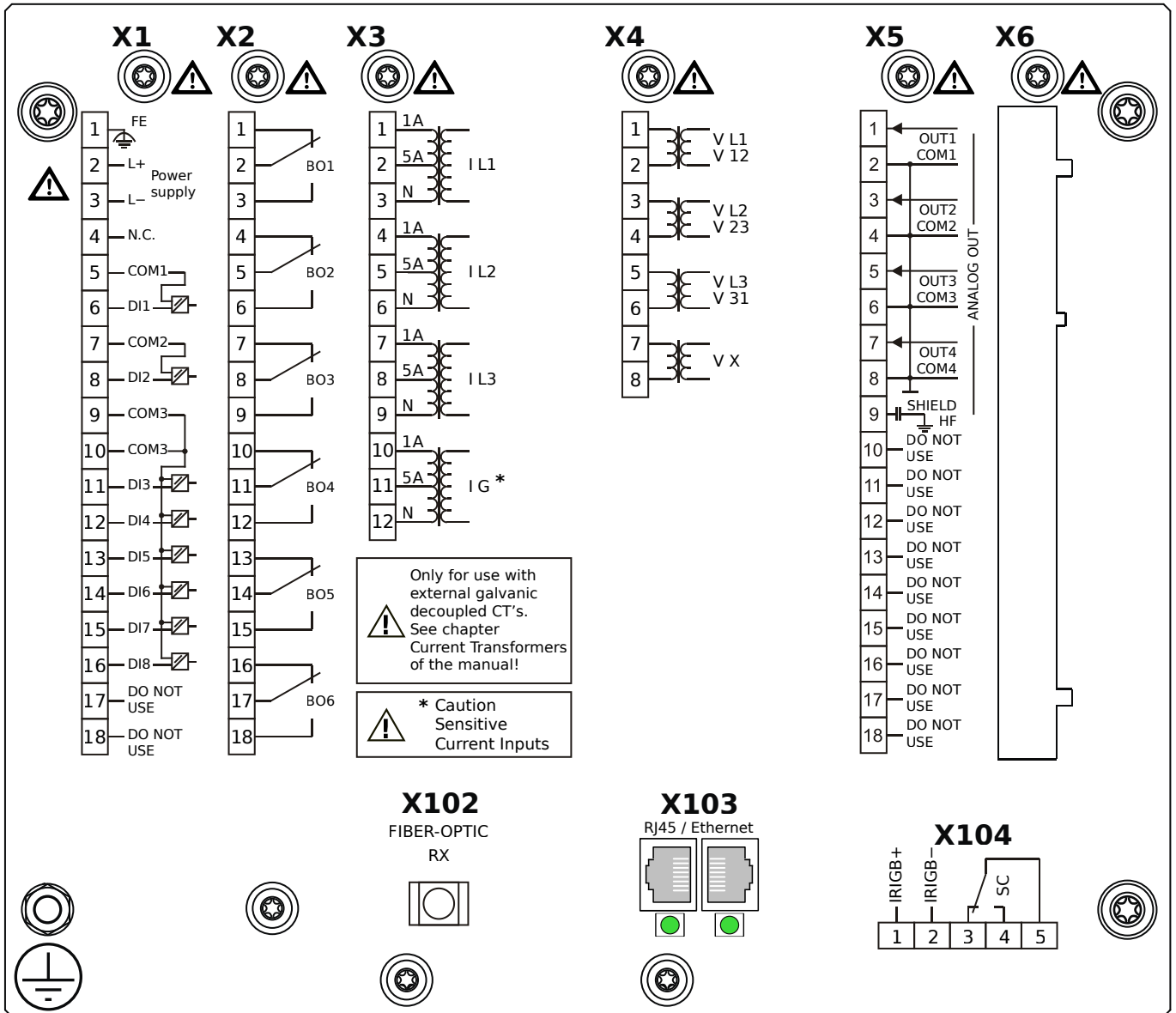

## Housing B2, small display, 19" rack mounting

+ Conformal Coating (for installations in harsh environment)

**X1** – DI8-X1: Wide-range power supply unit, incl. 2 non-grouped digital inputs and 6 grouped digital inputs

**X2** – OR6: Assembly Group with 6 Output Relays (Changeover / Form C)

**X3** – TIs: Standard phase current measuring card and sensitive ground current measuring

**X4** – TU: Card with 4 voltage transformer measuring inputs (0 ... 800 VAC, under UL: 0 ... 600 VAC)

**X5** – AnO4: Analog Outputs

**X102** – Universal Resistance-Temperature Detector (URTD) input, Fiber optics interface, Versatile Link

**X103** – IEC 61850 / Modbus TCP / IEC 60870-5-104 / DNP3.0 TCP/UDP, Redundant Ethernet interface, 100 Mbit/s, RJ45

(BASE100-FX)

**X104** – IRIG-B00X, incl. System Contact (Supervision Contact)

# MRMV4-2A1BTA

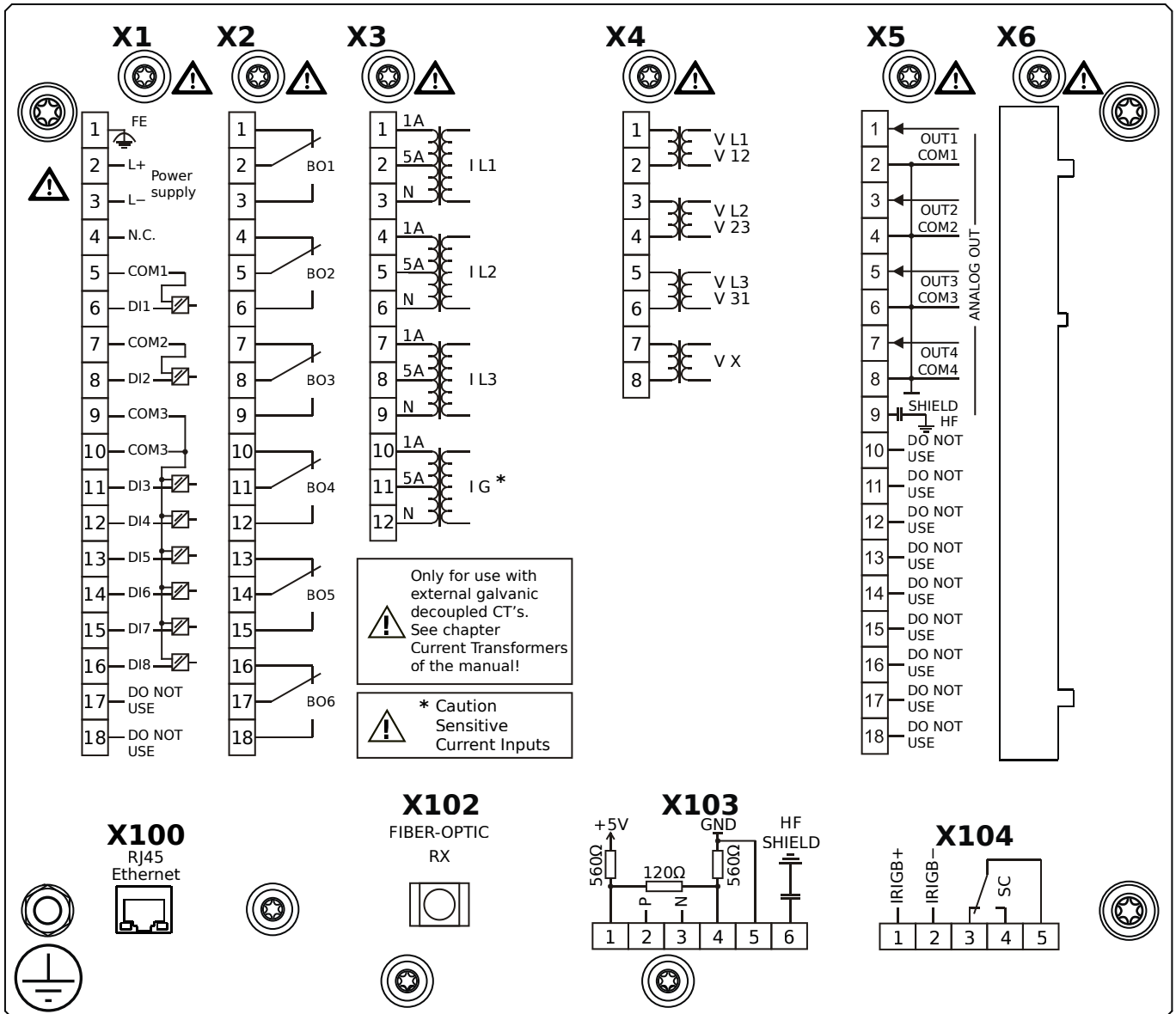

## Housing B2, small display, 19" rack mounting

- X1** – DI8-X1: Wide-range power supply unit, incl. 2 non-grouped digital inputs and 6 grouped digital inputs
- X2** – OR6: Assembly Group with 6 Output Relays (Changeover / Form C)
- X3** – TIs: Standard phase current measuring card and sensitive ground current measuring
- X4** – TU: Card with 4 voltage transformer measuring inputs (0 ... 800 VAC, under UL: 0 ... 600 VAC)
- X5** – AnO4: Analog Outputs
- X100** – IEC 61850 / Modbus TCP / IEC 60870-5-104 / DNP3.0 TCP/UDP, Ethernet interface, 100 Mbit/s, RJ45 (BASE100-FX)
- X102** – Universal Resistance-Temperature Detector (URTD) input, Fiber optics interface, Versatile Link
- X103** – IEC 60870-5-103 / Modbus RTU / DNP3.0 RTU, RS485, Terminals
- X104** – IRIG-B00X, incl. System Contact (Supervision Contact)



# MRMV4-2A1BTB

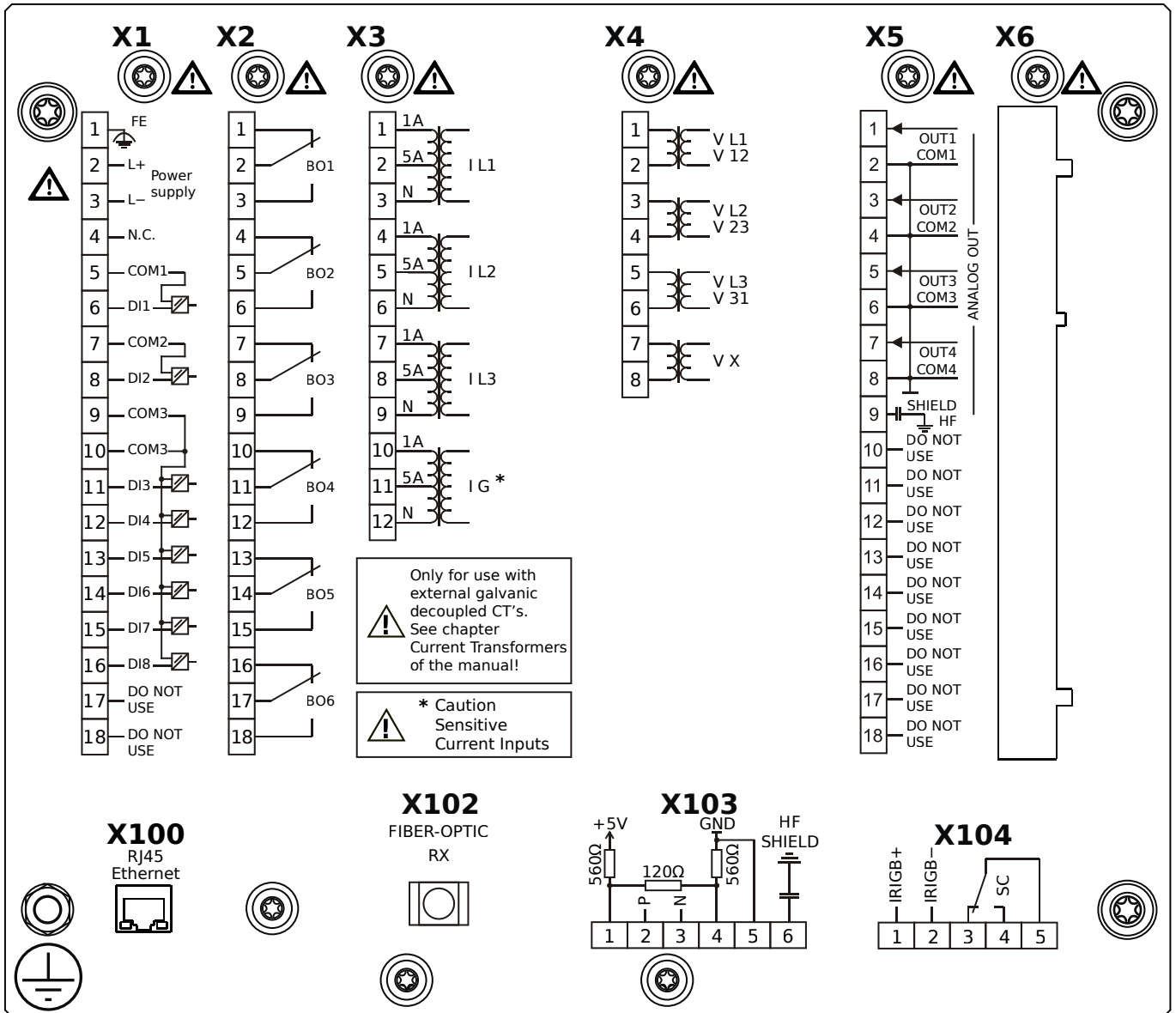

## Housing B2, small display, 19" rack mounting

+ Conformal Coating (for installations in harsh environment)

**X1** – DI8-X1: Wide-range power supply unit, incl. 2 non-grouped digital inputs and 6 grouped digital inputs

**X2** – OR6: Assembly Group with 6 Output Relays (Changeover / Form C)

**X3** – TIs: Standard phase current measuring card and sensitive ground current measuring

**X4** – TU: Card with 4 voltage transformer measuring inputs (0 ... 800 VAC, under UL: 0 ... 600 VAC)

**X5** – AnO4: Analog Outputs

**X100** – IEC 61850 / Modbus TCP / IEC 60870-5-104 / DNP3.0 TCP/UDP, Ethernet interface, 100 Mbit/s, RJ45 (BASE100-

FX)

**X102** – Universal Resistance-Temperature Detector (URTD) input, Fiber optics interface, Versatile Link

**X103** – IEC 60870-5-103 / Modbus RTU / DNP3.0 RTU, RS485, Terminals

**X104** – IRIG-B00X, incl. System Contact (Supervision Contact)

# MRMV4-2C0AAA

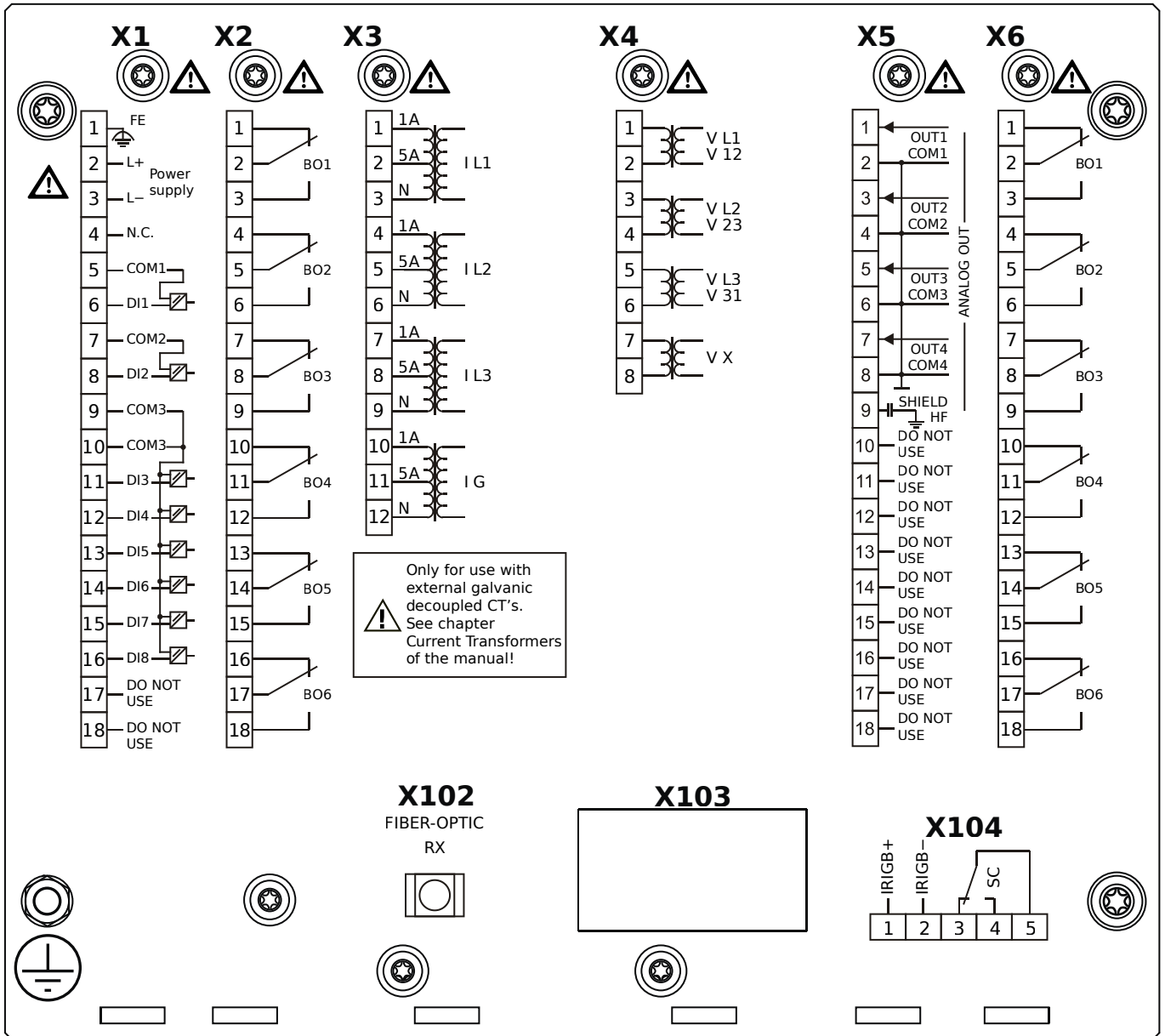

## Housing B2, small display, door mounting

- X1** – DI8-X1: Wide-range power supply unit, incl. 2 non-grouped digital inputs and 6 grouped digital inputs
- X2** – OR6: Assembly Group with 6 Output Relays (Changeover / Form C)
- X3** – TI: Standard current measuring card
- X4** – TU: Card with 4 voltage transformer measuring inputs (0 ... 800 VAC, under UL: 0 ... 600 VAC)
- X5** – AnO4: Analog Outputs
- X6** – OR6: Assembly Group with 6 Output Relays (Changeover / Form C)
- X102** – Universal Resistance-Temperature Detector (URTD) input, Fiber optics interface, Versatile Link
- X104** – IRIG-B00X, incl. System Contact (Supervision Contact)

# MRMV4-2C0AAB

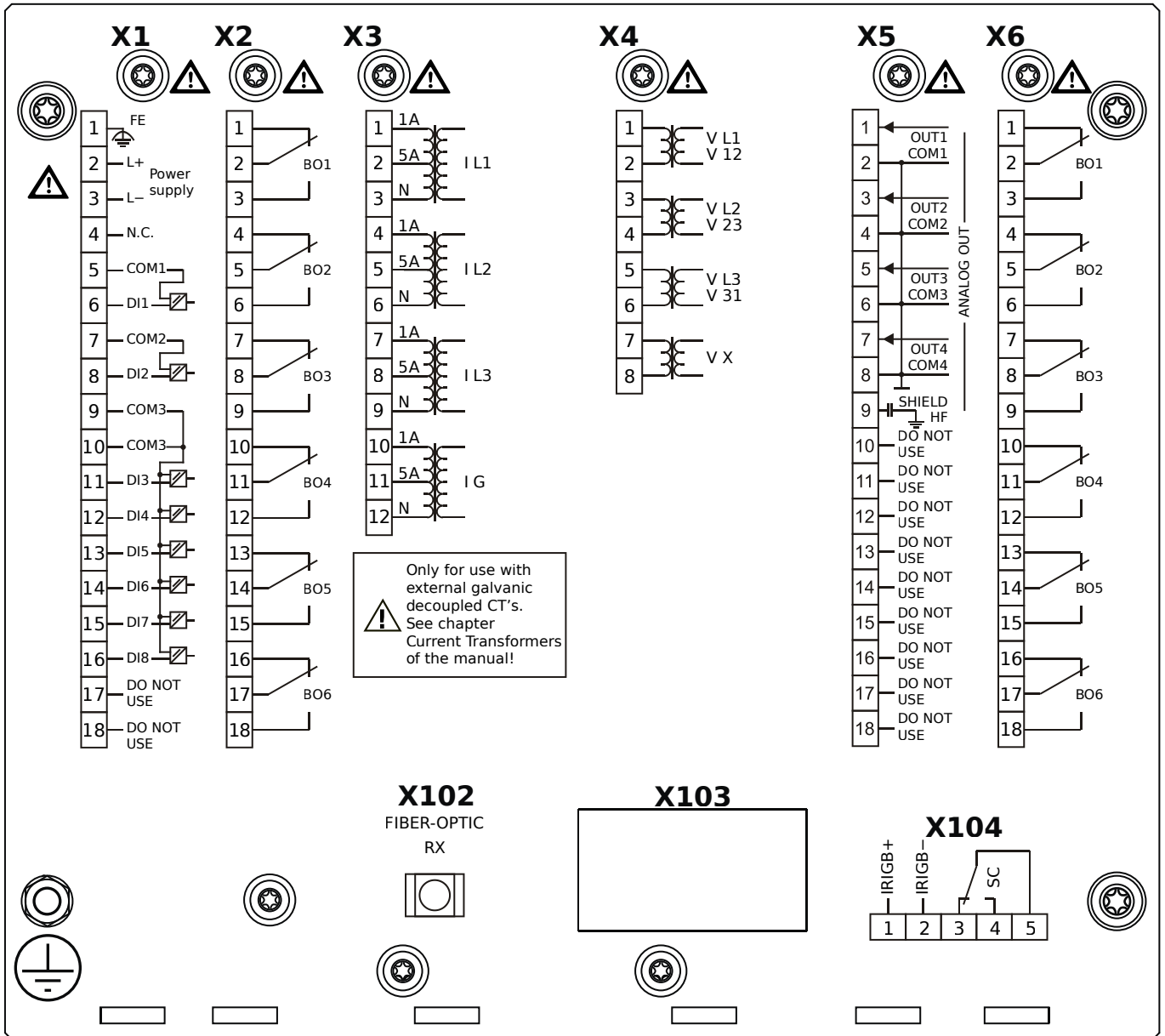

## Housing B2, small display, door mounting

+ Conformal Coating (for installations in harsh environment)

- X1** – DI8-X1: Wide-range power supply unit, incl. 2 non-grouped digital inputs and 6 grouped digital inputs
- X2** – OR6: Assembly Group with 6 Output Relays (Changeover / Form C)
- X3** – TI: Standard current measuring card
- X4** – TU: Card with 4 voltage transformer measuring inputs (0 ... 800 VAC, under UL: 0 ... 600 VAC)
- X5** – AnO4: Analog Outputs
- X6** – OR6: Assembly Group with 6 Output Relays (Changeover / Form C)
- X102** – Universal Resistance-Temperature Detector (URTD) input, Fiber optics interface, Versatile Link
- X104** – IRIG-B00X, incl. System Contact (Supervision Contact)

# MRMV4-2C0ABA

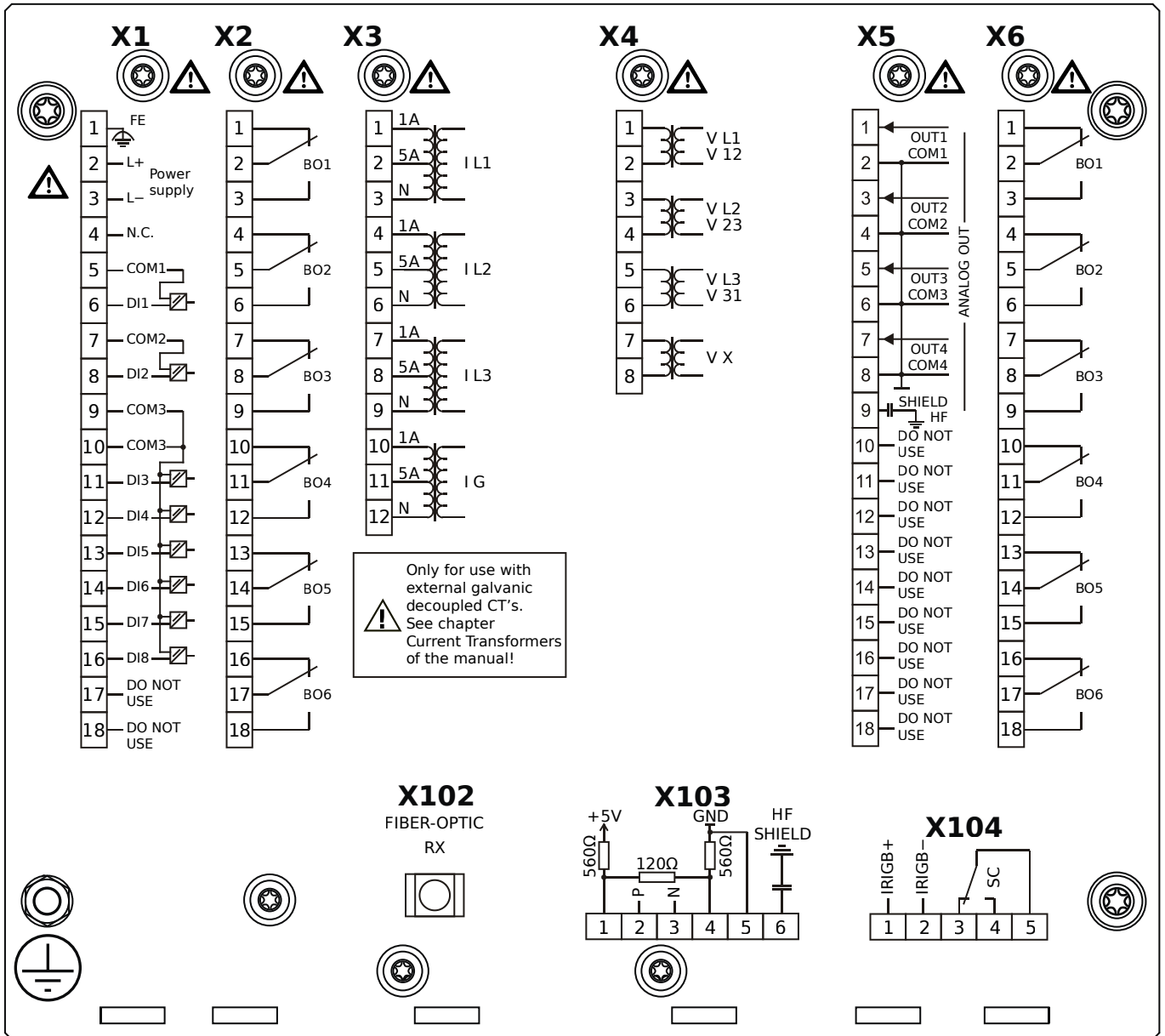

## Housing B2, small display, door mounting

- X1** – DI8-X1: Wide-range power supply unit, incl. 2 non-grouped digital inputs and 6 grouped digital inputs
- X2** – OR6: Assembly Group with 6 Output Relays (Changeover / Form C)
- X3** – TI: Standard current measuring card
- X4** – TU: Card with 4 voltage transformer measuring inputs (0 ... 800 VAC, under UL: 0 ... 600 VAC)
- X5** – AnO4: Analog Outputs
- X6** – OR6: Assembly Group with 6 Output Relays (Changeover / Form C)
- X102** – Universal Resistance-Temperature Detector (URTD) input, Fiber optics interface, Versatile Link
- X103** – Modbus RTU / IEC 60870-5-103 / DNP3.0 RTU, RS485, Terminals
- X104** – IRIG-B00X, incl. System Contact (Supervision Contact)

# MRMV4-2C0ABB

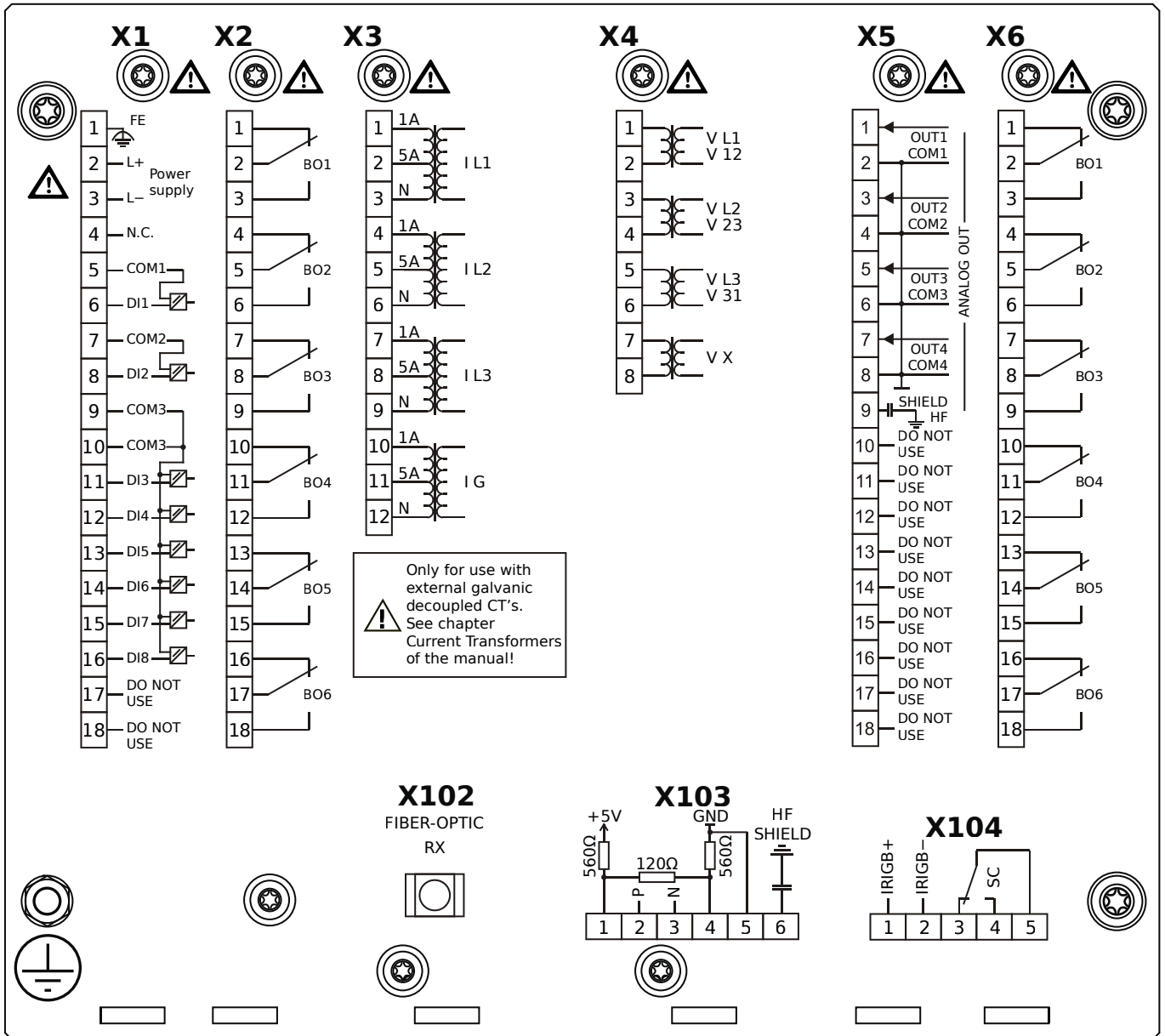

## Housing B2, small display, door mounting

+ Conformal Coating (for installations in harsh environment)

- X1** – DI8-X1: Wide-range power supply unit, incl. 2 non-grouped digital inputs and 6 grouped digital inputs
- X2** – OR6: Assembly Group with 6 Output Relays (Changeover / Form C)
- X3** – TI: Standard current measuring card
- X4** – TU: Card with 4 voltage transformer measuring inputs (0 ... 800 VAC, under UL: 0 ... 600 VAC)
- X5** – AnO4: Analog Outputs
- X6** – OR6: Assembly Group with 6 Output Relays (Changeover / Form C)
- X102** – Universal Resistance-Temperature Detector (URTD) input, Fiber optics interface, Versatile Link
- X103** – Modbus RTU / IEC 60870-5-103 / DNP3.0 RTU, RS485, Terminals
- X104** – IRIG-B00X, incl. System Contact (Supervision Contact)

# MRMV4-2C0ACA

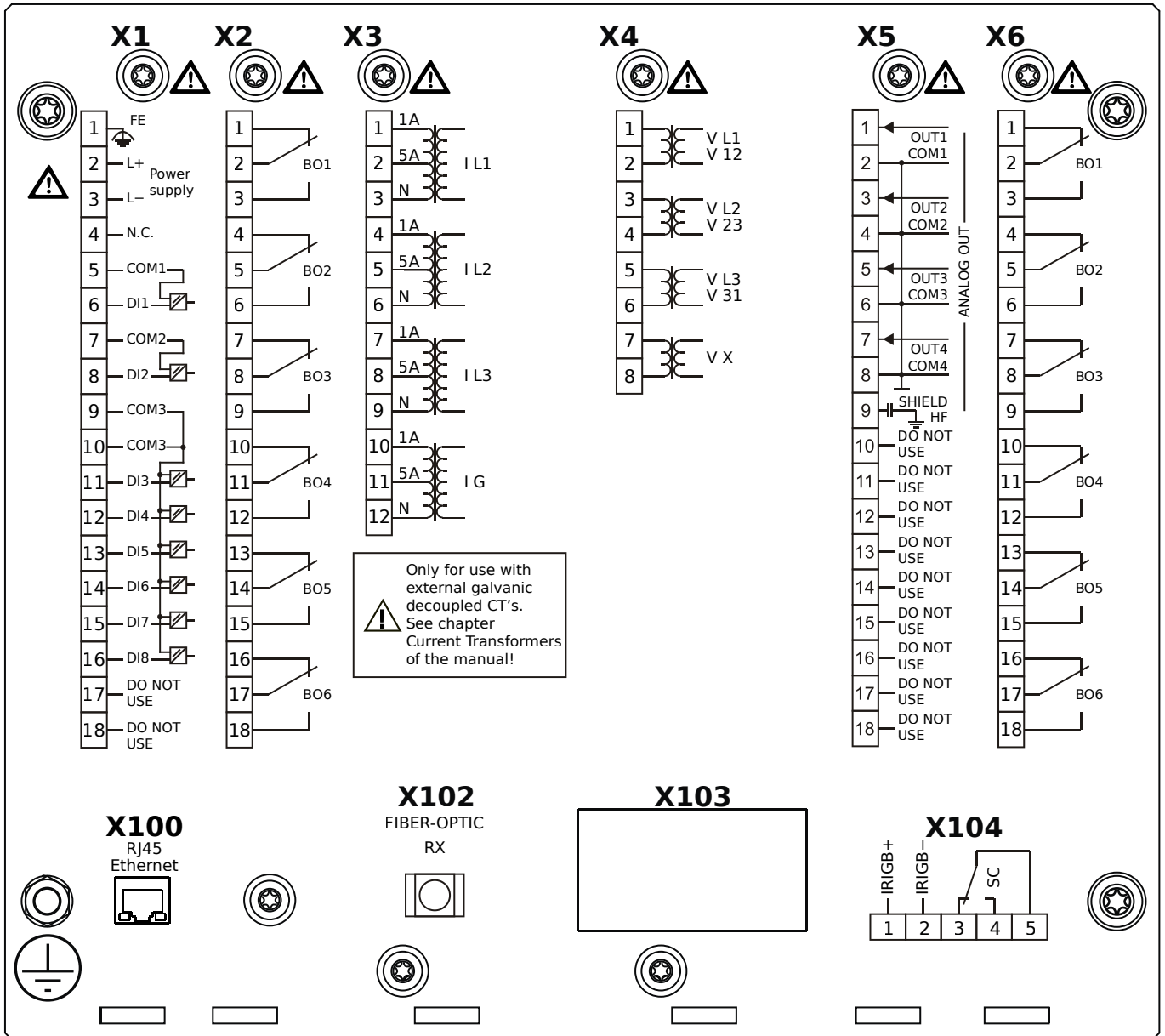

## Housing B2, small display, door mounting

- X1** – DI8-X1: Wide-range power supply unit, incl. 2 non-grouped digital inputs and 6 grouped digital inputs
- X2** – OR6: Assembly Group with 6 Output Relays (Changeover / Form C)
- X3** – TI: Standard current measuring card
- X4** – TU: Card with 4 voltage transformer measuring inputs (0 ... 800 VAC, under UL: 0 ... 600 VAC)
- X5** – AnO4: Analog Outputs
- X6** – OR6: Assembly Group with 6 Output Relays (Changeover / Form C)
- X100** – Modbus TCP / IEC 60870-5-104 / DNP3.0 TCP/UDP, Ethernet interface, 100 Mbit/s, RJ45 (BASE100-FX)
- X102** – Universal Resistance-Temperature Detector (URTD) input, Fiber optics interface, Versatile Link
- X104** – IRIG-B00X, incl. System Contact (Supervision Contact)

# MRMV4-2C0ACB

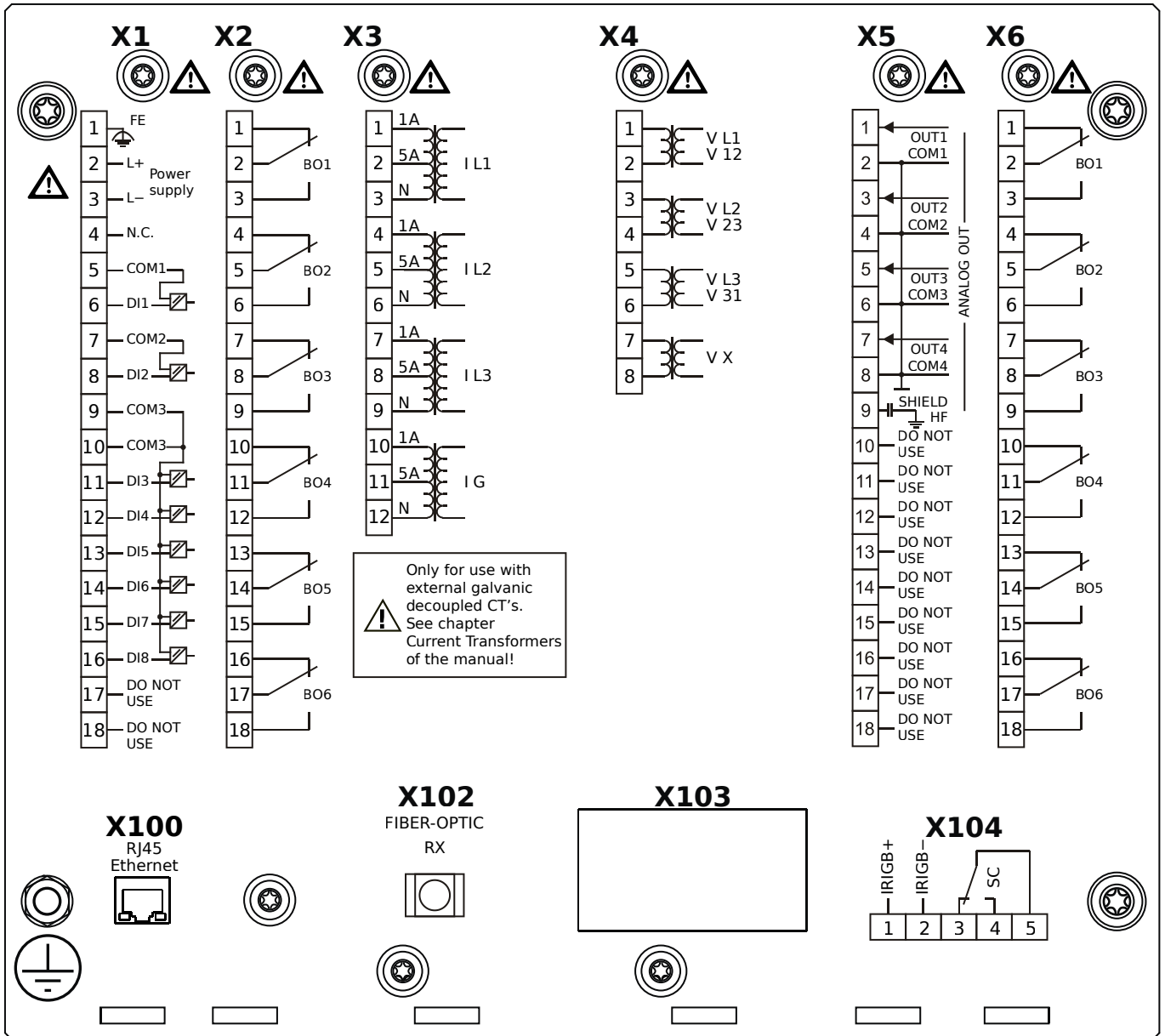

## Housing B2, small display, door mounting

- + Conformal Coating (for installations in harsh environment)

- X1** – DI8-X1: Wide-range power supply unit, incl. 2 non-grouped digital inputs and 6 grouped digital inputs
- X2** – OR6: Assembly Group with 6 Output Relays (Changeover / Form C)
- X3** – TI: Standard current measuring card
- X4** – TU: Card with 4 voltage transformer measuring inputs (0 ... 800 VAC, under UL: 0 ... 600 VAC)
- X5** – AnO4: Analog Outputs
- X6** – OR6: Assembly Group with 6 Output Relays (Changeover / Form C)
- X100** – Modbus TCP / IEC 60870-5-104 / DNP3.0 TCP/UDP, Ethernet interface, 100 Mbit/s, RJ45 (BASE100-FX)
- X102** – Universal Resistance-Temperature Detector (URTD) input, Fiber optics interface, Versatile Link
- X104** – IRIG-B00X, incl. System Contact (Supervision Contact)

# MRMV4-2C0ADA

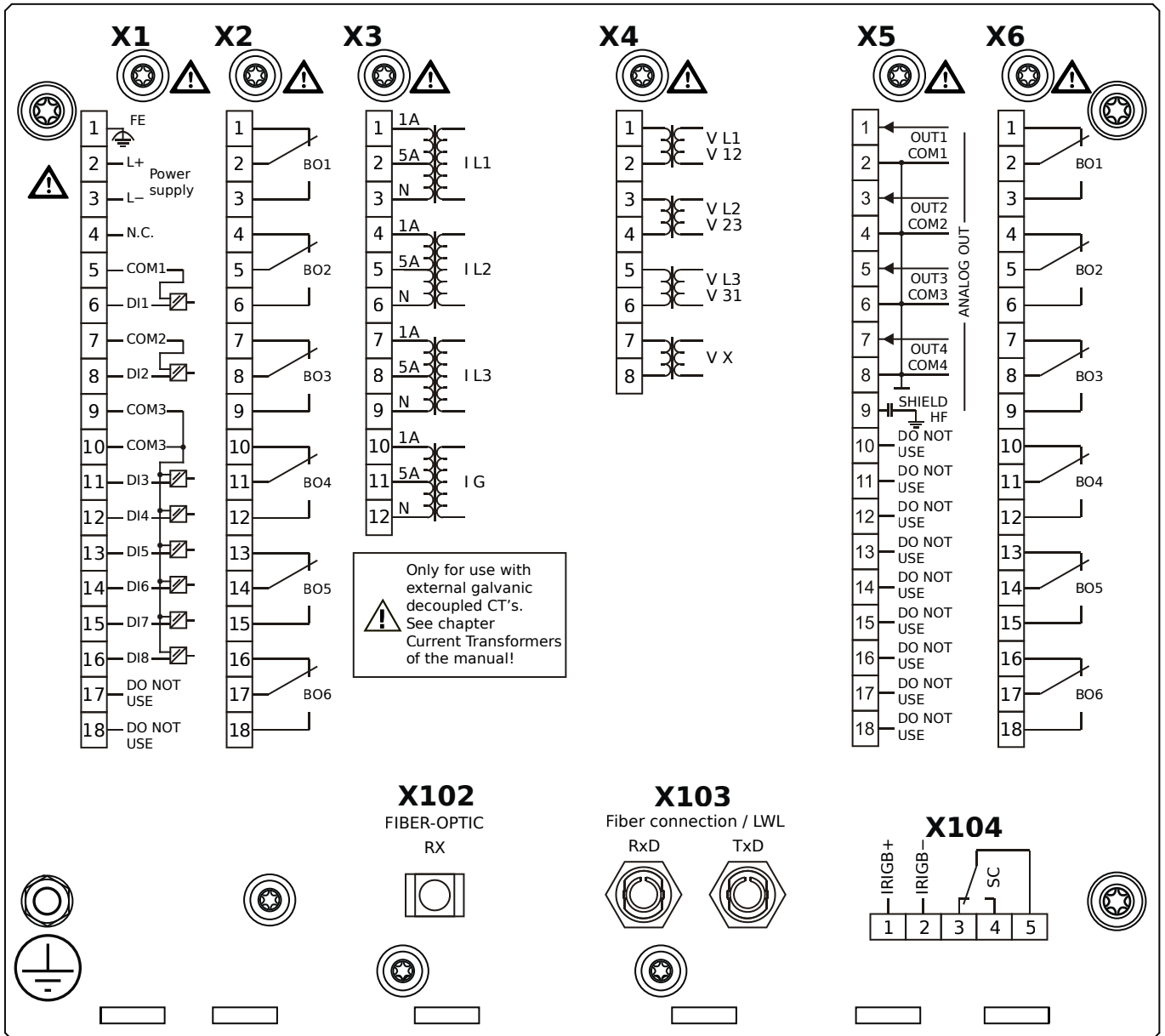

## Housing B2, small display, door mounting

- X1** – DI8-X1: Wide-range power supply unit, incl. 2 non-grouped digital inputs and 6 grouped digital inputs
- X2** – OR6: Assembly Group with 6 Output Relays (Changeover / Form C)
- X3** – TI: Standard current measuring card
- X4** – TU: Card with 4 voltage transformer measuring inputs (0 ... 800 VAC, under UL: 0 ... 600 VAC)
- X5** – AnO4: Analog Outputs
- X6** – OR6: Assembly Group with 6 Output Relays (Changeover / Form C)
- X102** – Universal Resistance-Temperature Detector (URTD) input, Fiber optics interface, Versatile Link
- X103** – Profibus-DP, Fiber optics interface, ST Connector
- X104** – IRIG-B00X, incl. System Contact (Supervision Contact)



# MRMV4-2C0ADB

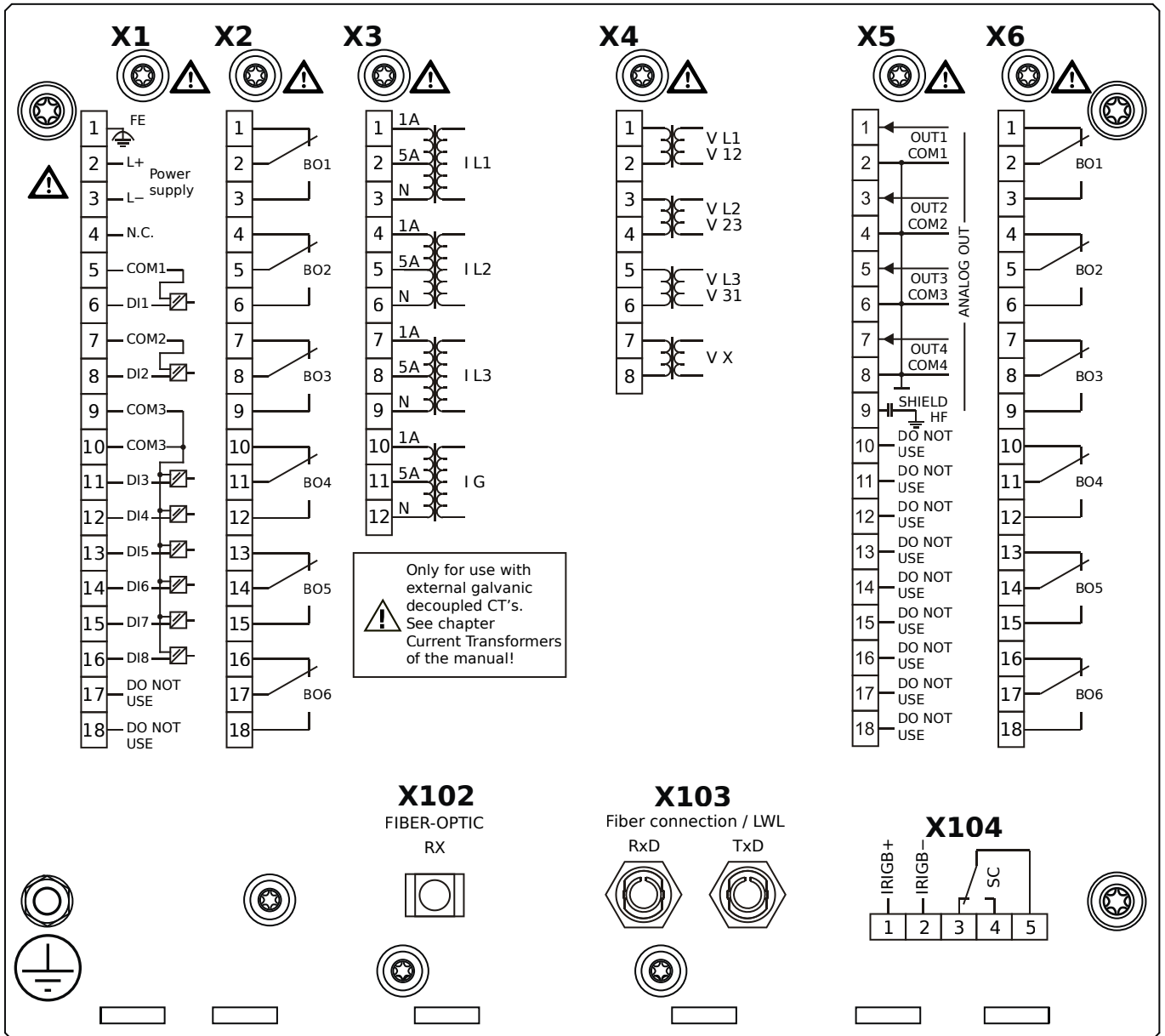

## Housing B2, small display, door mounting

+ Conformal Coating (for installations in harsh environment)

- X1** – DI8-X1: Wide-range power supply unit, incl. 2 non-grouped digital inputs and 6 grouped digital inputs
- X2** – OR6: Assembly Group with 6 Output Relays (Changeover / Form C)
- X3** – TI: Standard current measuring card
- X4** – TU: Card with 4 voltage transformer measuring inputs (0 ... 800 VAC, under UL: 0 ... 600 VAC)
- X5** – AnO4: Analog Outputs
- X6** – OR6: Assembly Group with 6 Output Relays (Changeover / Form C)
- X102** – Universal Resistance-Temperature Detector (URTD) input, Fiber optics interface, Versatile Link
- X103** – Profibus-DP, Fiber optics interface, ST Connector
- X104** – IRIG-B00X, incl. System Contact (Supervision Contact)

# MRMV4-2C0AEA

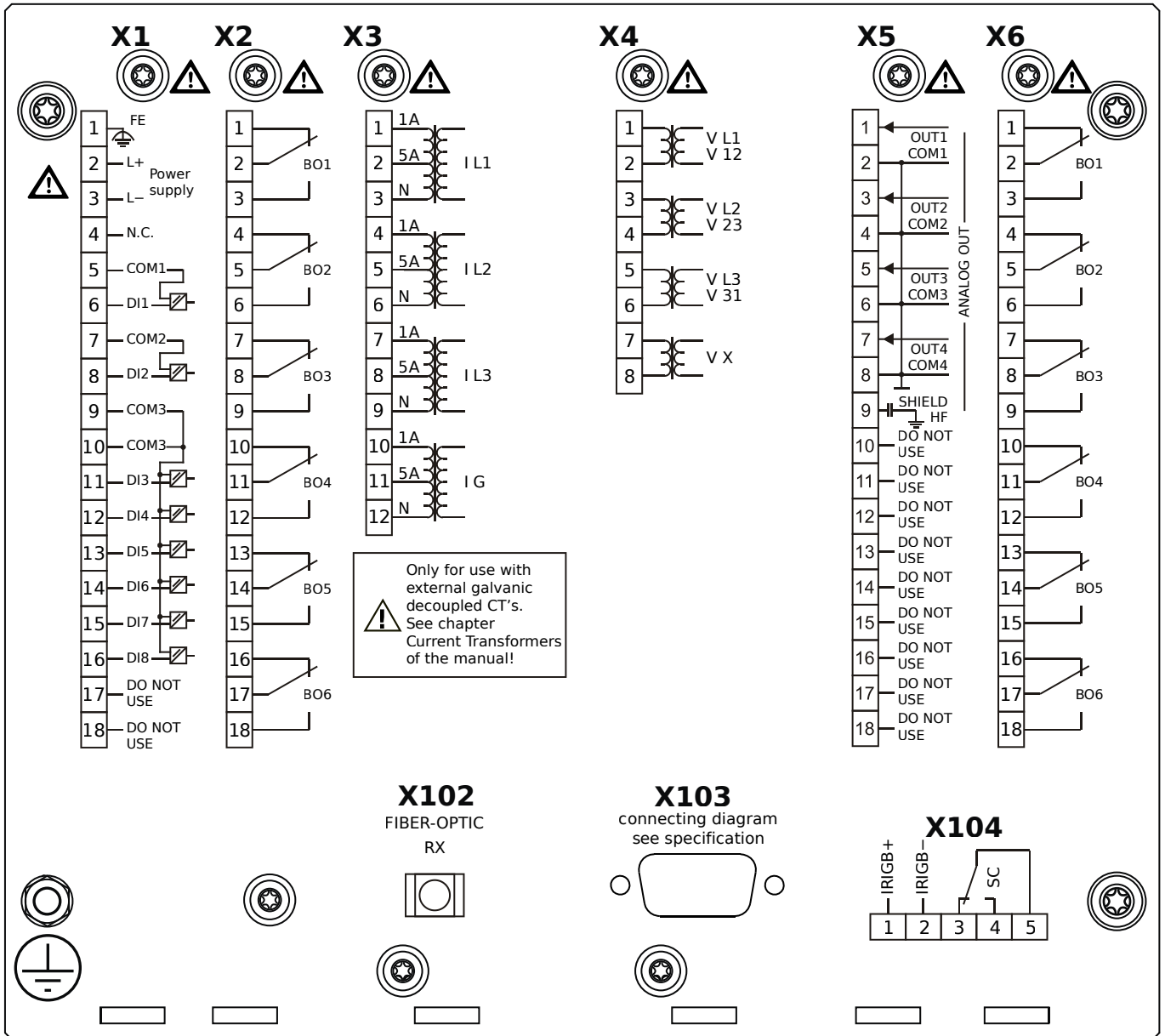

## Housing B2, small display, door mounting

- X1** – DI8-X1: Wide-range power supply unit, incl. 2 non-grouped digital inputs and 6 grouped digital inputs
- X2** – OR6: Assembly Group with 6 Output Relays (Changeover / Form C)
- X3** – TI: Standard current measuring card
- X4** – TU: Card with 4 voltage transformer measuring inputs (0 ... 800 VAC, under UL: 0 ... 600 VAC)
- X5** – AnO4: Analog Outputs
- X6** – OR6: Assembly Group with 6 Output Relays (Changeover / Form C)
- X102** – Universal Resistance-Temperature Detector (URTD) input, Fiber optics interface, Versatile Link
- X103** – Profibus-DP, RS485, D-SUB
- X104** – IRIG-B00X, incl. System Contact (Supervision Contact)

# MRMV4-2C0AEB

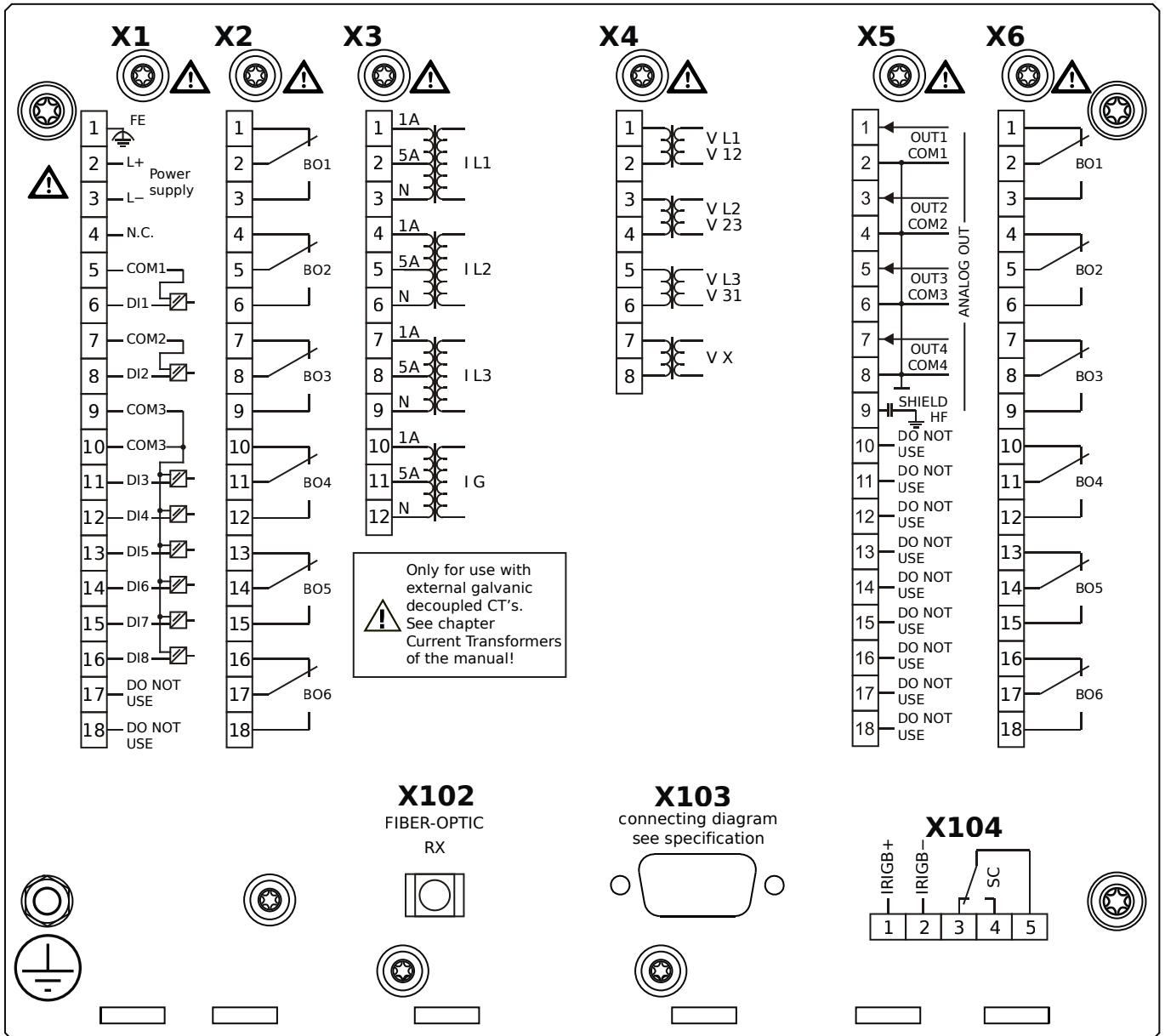

## Housing B2, small display, door mounting

+ Conformal Coating (for installations in harsh environment)

- X1** – DI8-X1: Wide-range power supply unit, incl. 2 non-grouped digital inputs and 6 grouped digital inputs
- X2** – OR6: Assembly Group with 6 Output Relays (Changeover / Form C)
- X3** – TI: Standard current measuring card
- X4** – TU: Card with 4 voltage transformer measuring inputs (0 ... 800 VAC, under UL: 0 ... 600 VAC)
- X5** – AnO4: Analog Outputs
- X6** – OR6: Assembly Group with 6 Output Relays (Changeover / Form C)
- X102** – Universal Resistance-Temperature Detector (URTD) input, Fiber optics interface, Versatile Link
- X103** – Profibus-DP, RS485, D-SUB
- X104** – IRIG-B00X, incl. System Contact (Supervision Contact)

# MRMV4-2C0AFA

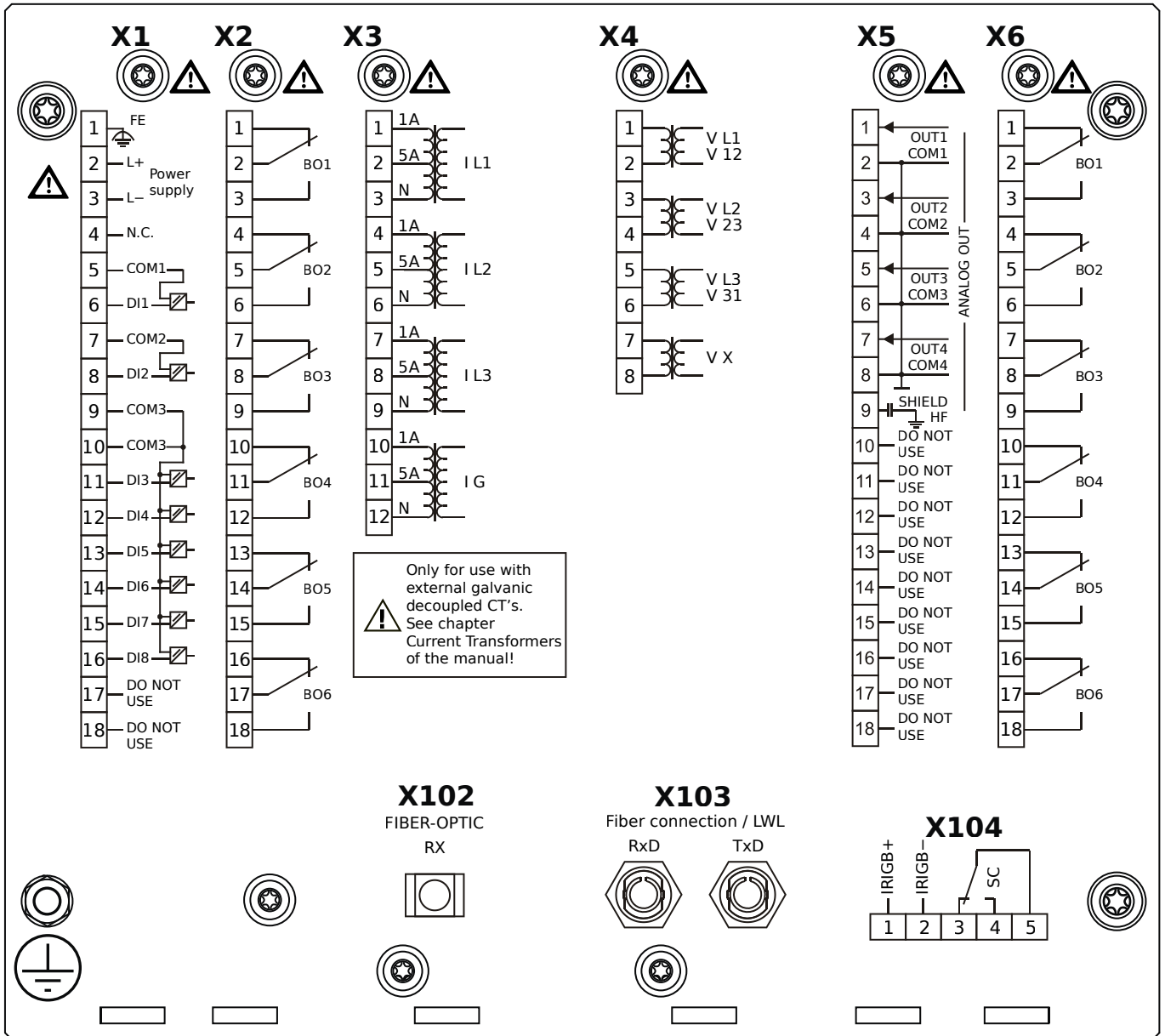

## Housing B2, small display, door mounting

- X1** – DI8-X1: Wide-range power supply unit, incl. 2 non-grouped digital inputs and 6 grouped digital inputs
- X2** – OR6: Assembly Group with 6 Output Relays (Changeover / Form C)
- X3** – TI: Standard current measuring card
- X4** – TU: Card with 4 voltage transformer measuring inputs (0 ... 800 VAC, under UL: 0 ... 600 VAC)
- X5** – AnO4: Analog Outputs
- X6** – OR6: Assembly Group with 6 Output Relays (Changeover / Form C)
- X102** – Universal Resistance-Temperature Detector (URTD) input, Fiber optics interface, Versatile Link
- X103** – Modbus RTU / IEC 60870-5-103 / DNP3.0 RTU, Fiber optics interface, ST Connector
- X104** – IRIG-B00X, incl. System Contact (Supervision Contact)

# MRMV4-2C0AFB

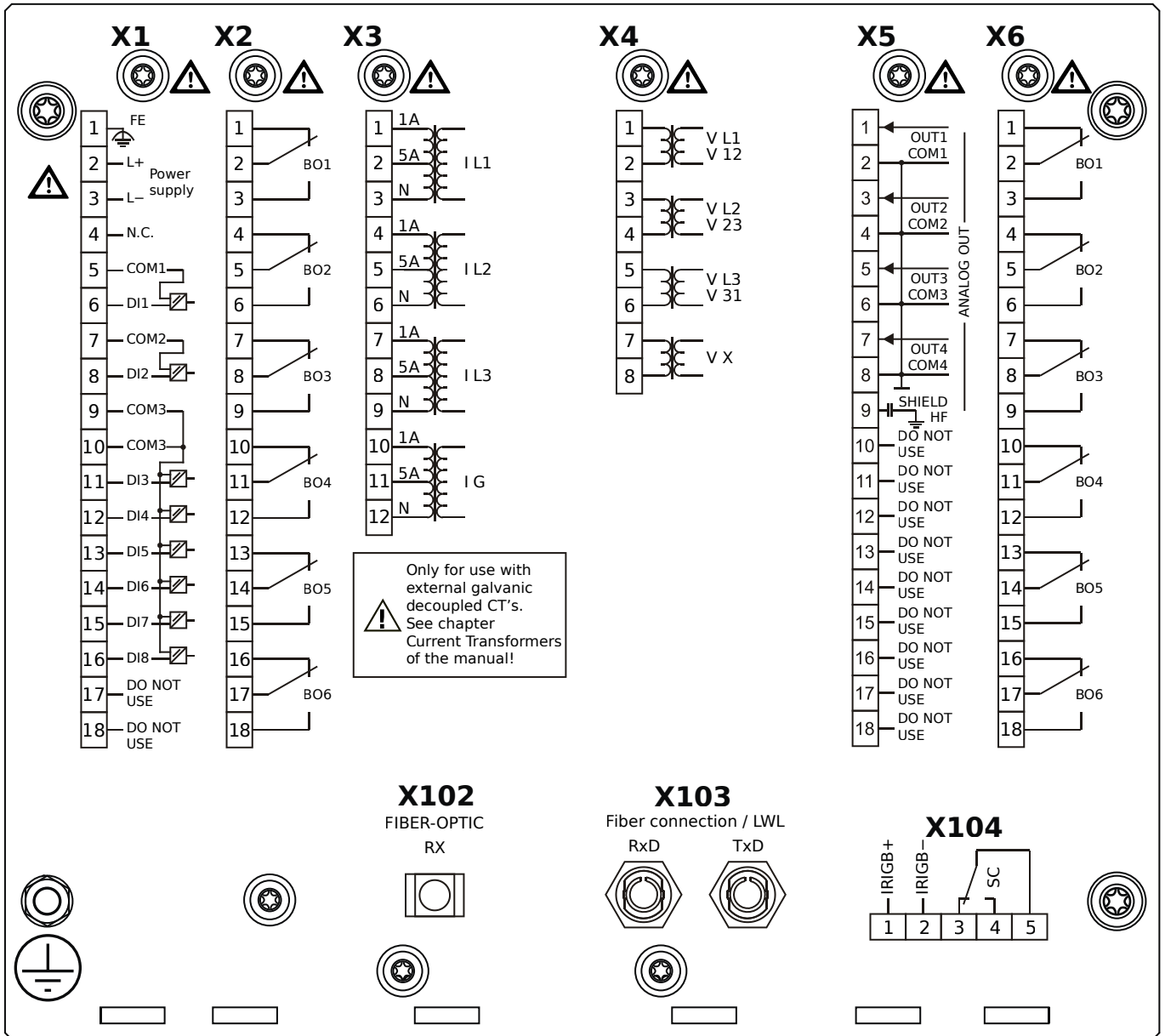

## Housing B2, small display, door mounting

+ Conformal Coating (for installations in harsh environment)

- X1** – DI8-X1: Wide-range power supply unit, incl. 2 non-grouped digital inputs and 6 grouped digital inputs
- X2** – OR6: Assembly Group with 6 Output Relays (Changeover / Form C)
- X3** – TI: Standard current measuring card
- X4** – TU: Card with 4 voltage transformer measuring inputs (0 ... 800 VAC, under UL: 0 ... 600 VAC)
- X5** – AnO4: Analog Outputs
- X6** – OR6: Assembly Group with 6 Output Relays (Changeover / Form C)
- X102** – Universal Resistance-Temperature Detector (URTD) input, Fiber optics interface, Versatile Link
- X103** – Modbus RTU / IEC 60870-5-103 / DNP3.0 RTU, Fiber optics interface, ST Connector
- X104** – IRIG-B00X, incl. System Contact (Supervision Contact)

# MRMV4-2C0AGA

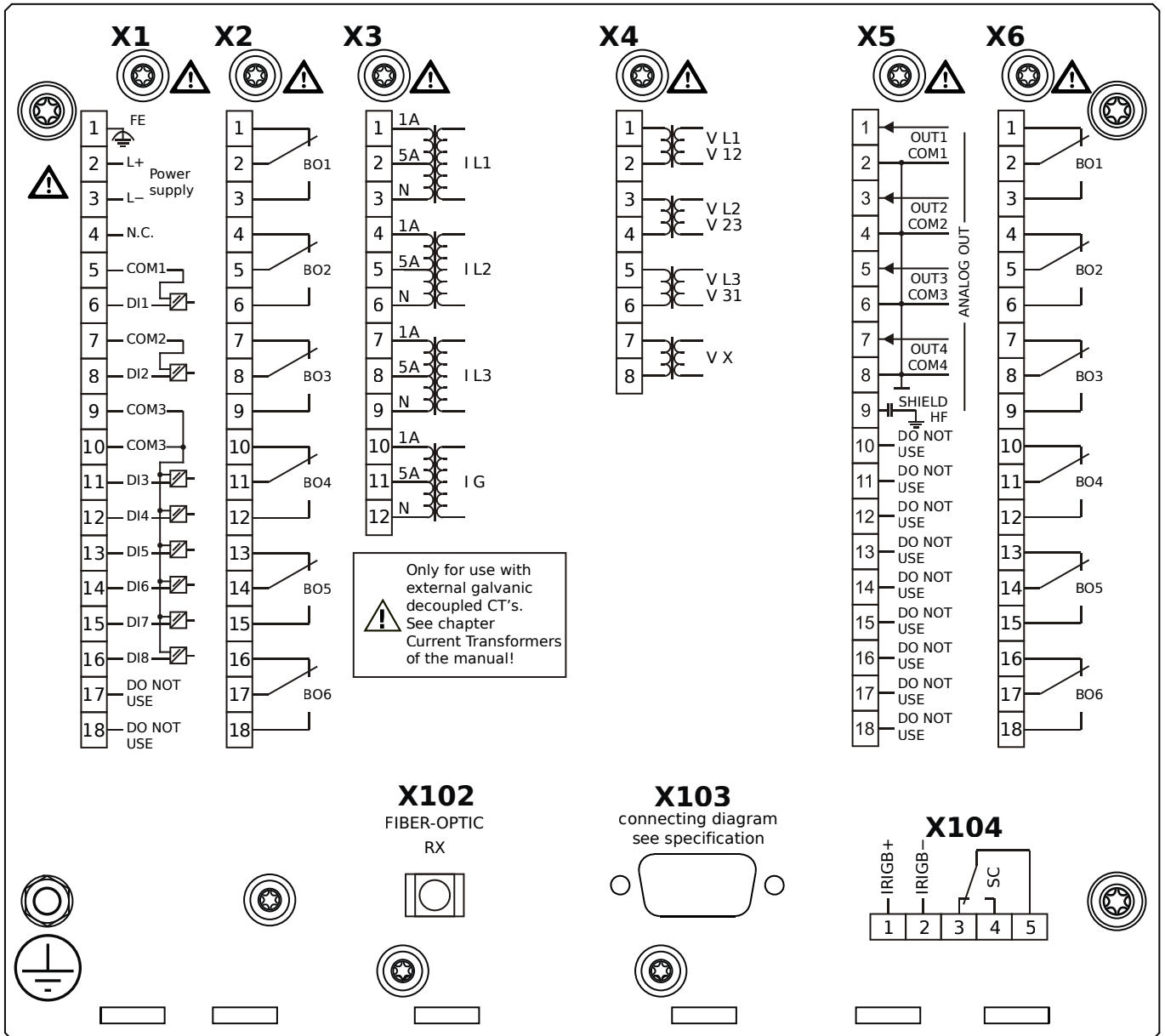

## Housing B2, small display, door mounting

- X1** – DI8-X1: Wide-range power supply unit, incl. 2 non-grouped digital inputs and 6 grouped digital inputs
- X2** – OR6: Assembly Group with 6 Output Relays (Changeover / Form C)
- X3** – TI: Standard current measuring card
- X4** – TU: Card with 4 voltage transformer measuring inputs (0 ... 800 VAC, under UL: 0 ... 600 VAC)
- X5** – AnO4: Analog Outputs
- X6** – OR6: Assembly Group with 6 Output Relays (Changeover / Form C)
- X102** – Universal Resistance-Temperature Detector (URTD) input, Fiber optics interface, Versatile Link
- X103** – Modbus RTU / IEC 60870-5-103 / DNP3.0 RTU, RS485, D-SUB
- X104** – IRIG-B00X, incl. System Contact (Supervision Contact)

# MRMV4-2C0AGB

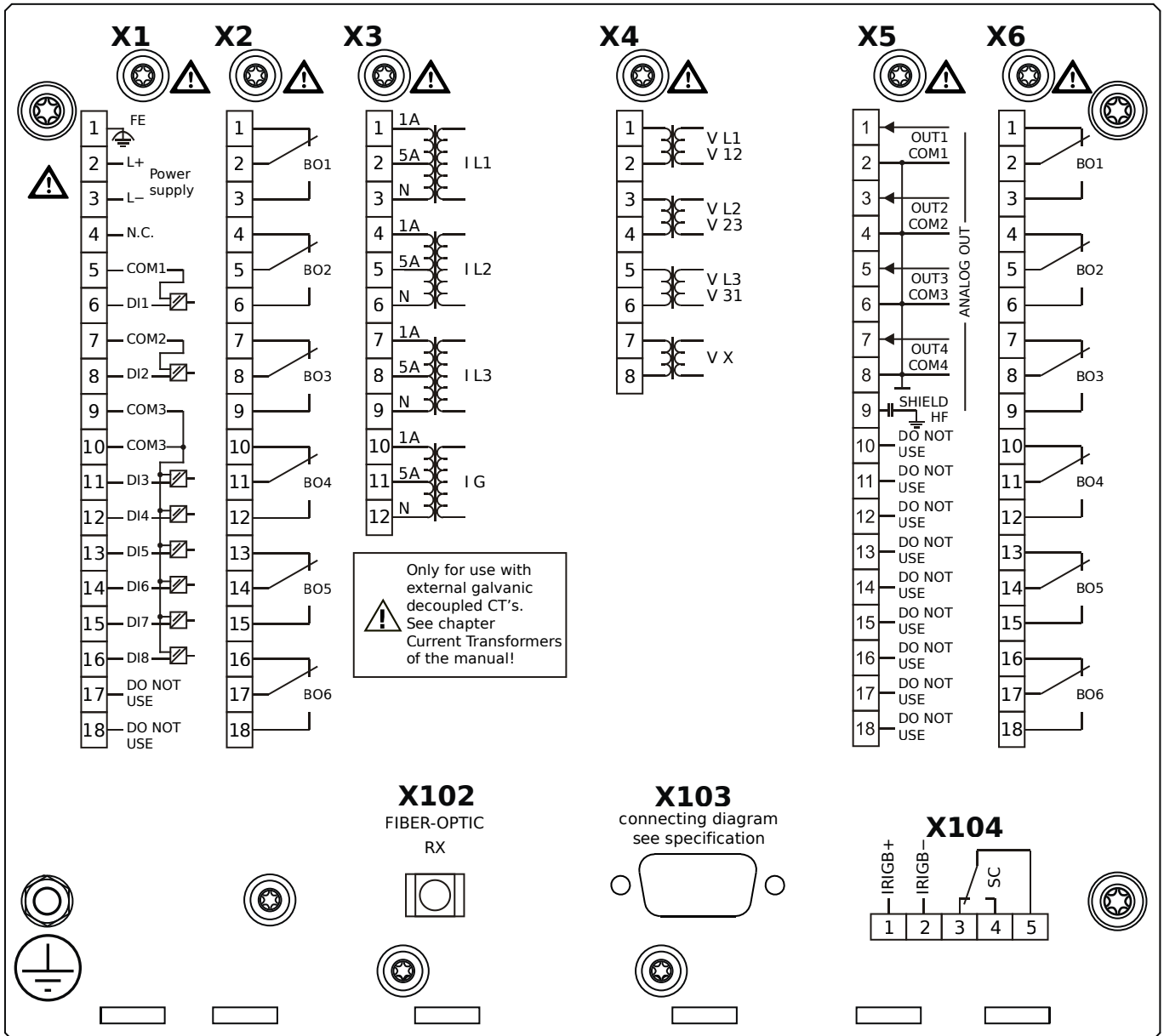

## Housing B2, small display, door mounting

+ Conformal Coating (for installations in harsh environment)

- X1** – DI8-X1: Wide-range power supply unit, incl. 2 non-grouped digital inputs and 6 grouped digital inputs
- X2** – OR6: Assembly Group with 6 Output Relays (Changeover / Form C)
- X3** – TI: Standard current measuring card
- X4** – TU: Card with 4 voltage transformer measuring inputs (0 ... 800 VAC, under UL: 0 ... 600 VAC)
- X5** – AnO4: Analog Outputs
- X6** – OR6: Assembly Group with 6 Output Relays (Changeover / Form C)
- X102** – Universal Resistance-Temperature Detector (URTD) input, Fiber optics interface, Versatile Link
- X103** – Modbus RTU / IEC 60870-5-103 / DNP3.0 RTU, RS485, D-SUB
- X104** – IRIG-B00X, incl. System Contact (Supervision Contact)

# MRMV4-2C0AHA

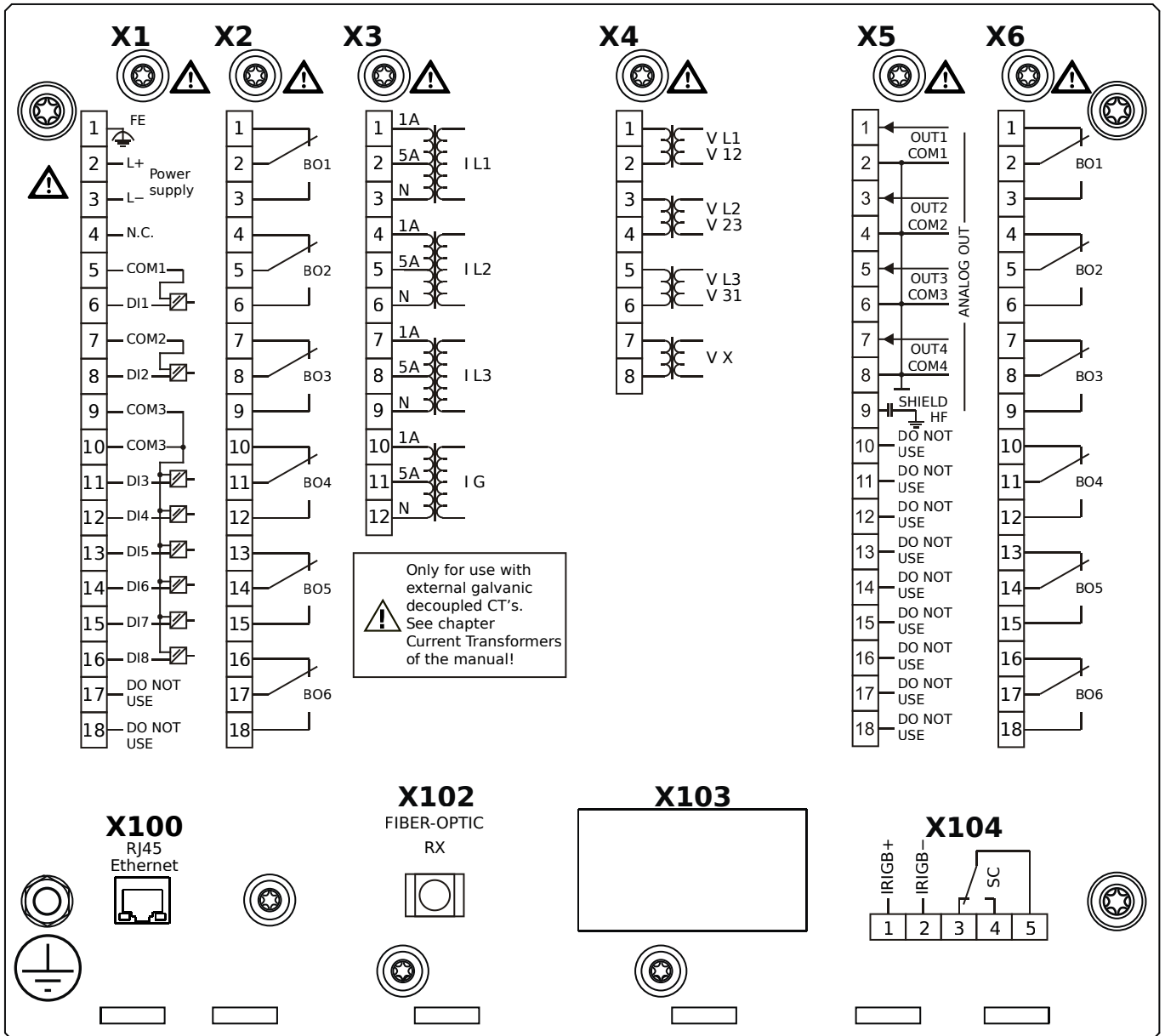

## Housing B2, small display, door mounting

- X1** – DI8-X1: Wide-range power supply unit, incl. 2 non-grouped digital inputs and 6 grouped digital inputs
- X2** – OR6: Assembly Group with 6 Output Relays (Changeover / Form C)
- X3** – TI: Standard current measuring card
- X4** – TU: Card with 4 voltage transformer measuring inputs (0 ... 800 VAC, under UL: 0 ... 600 VAC)
- X5** – AnO4: Analog Outputs
- X6** – OR6: Assembly Group with 6 Output Relays (Changeover / Form C)
- X100** – IEC 61850 / Modbus TCP / IEC 60870-5-104 / DNP3.0 TCP/UDP, Ethernet interface, 100 Mbit/s, RJ45 (BASE100-FX)
- X102** – Universal Resistance-Temperature Detector (URTD) input, Fiber optics interface, Versatile Link
- X104** – IRIG-B00X, incl. System Contact (Supervision Contact)



# MRMV4-2C0AHB

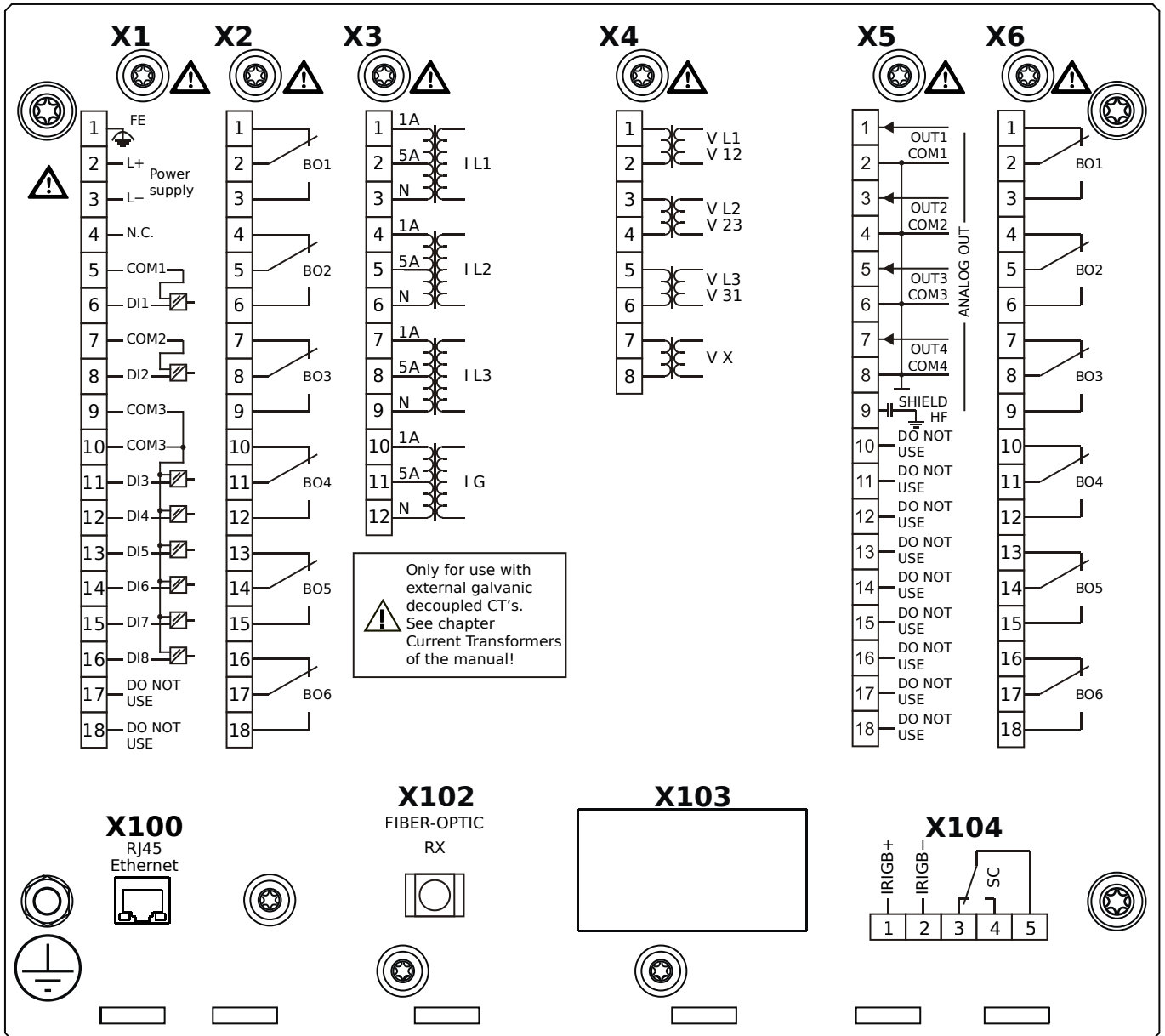

## Housing B2, small display, door mounting

+ Conformal Coating (for installations in harsh environment)

**X1** – DI8-X1: Wide-range power supply unit, incl. 2 non-grouped digital inputs and 6 grouped digital inputs

**X2** – OR6: Assembly Group with 6 Output Relays (Changeover / Form C)

**X3** – TI: Standard current measuring card

**X4** – TU: Card with 4 voltage transformer measuring inputs (0 ... 800 VAC, under UL: 0 ... 600 VAC)

**X5** – AnO4: Analog Outputs

**X6** – OR6: Assembly Group with 6 Output Relays (Changeover / Form C)

**X100** – IEC 61850 / Modbus TCP / IEC 60870-5-104 / DNP3.0 TCP/UDP, Ethernet interface, 100 Mbit/s, RJ45 (BASE100-

FX)

**X102** – Universal Resistance-Temperature Detector (URTD) input, Fiber optics interface, Versatile Link

**X104** – IRIG-B00X, incl. System Contact (Supervision Contact)

# MRMV4-2C0AIA

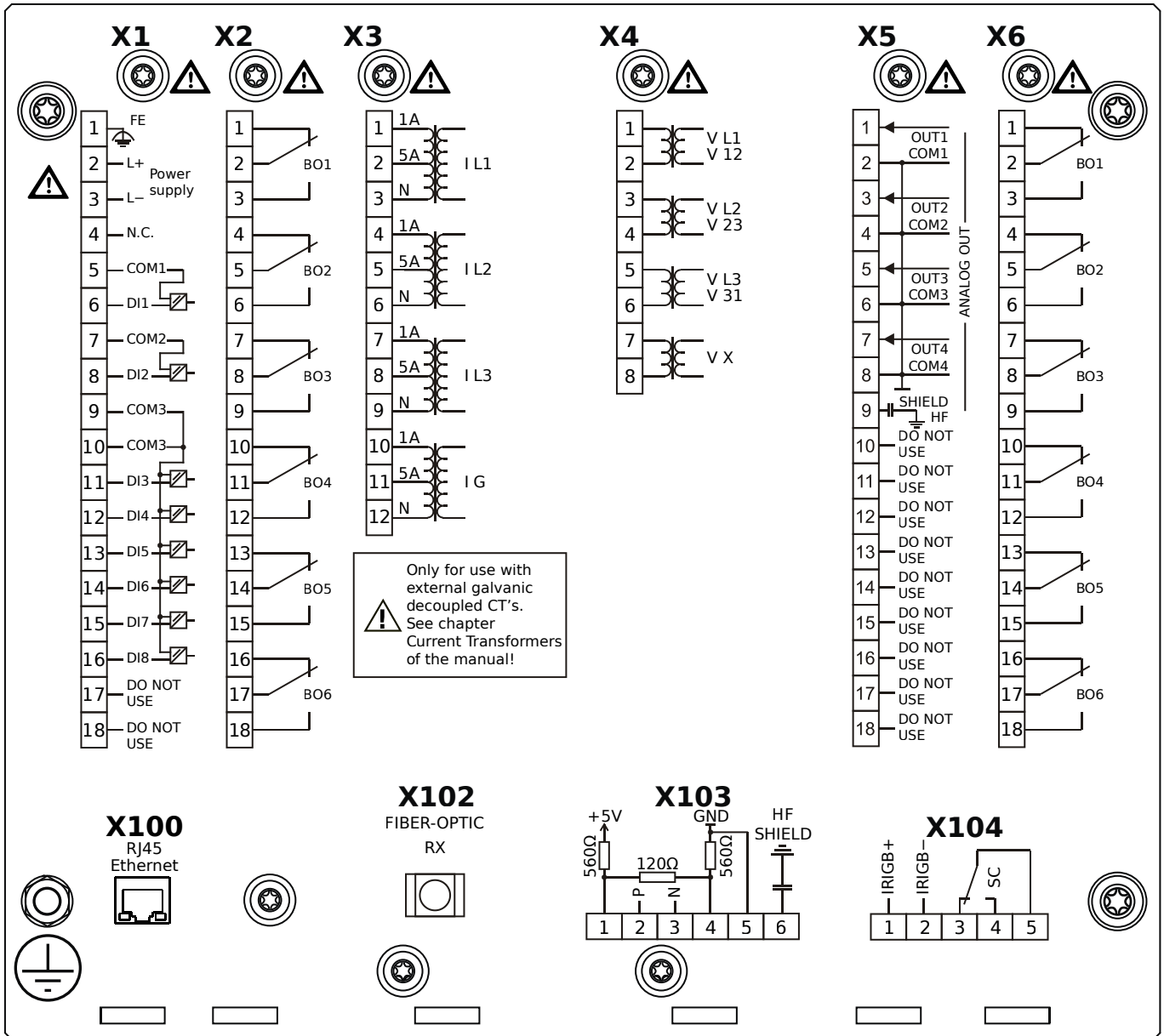

## Housing B2, small display, door mounting

- X1** – DI8-X1: Wide-range power supply unit, incl. 2 non-grouped digital inputs and 6 grouped digital inputs
- X2** – OR6: Assembly Group with 6 Output Relays (Changeover / Form C)
- X3** – TI: Standard current measuring card
- X4** – TU: Card with 4 voltage transformer measuring inputs (0 ... 800 VAC, under UL: 0 ... 600 VAC)
- X5** – AnO4: Analog Outputs
- X6** – OR6: Assembly Group with 6 Output Relays (Changeover / Form C)
- X100** – Modbus TCP / IEC 60870-5-104 / DNP3.0 TCP/UDP, Ethernet interface, 100 Mbit/s, RJ45 (BASE100-FX)
- X102** – Universal Resistance-Temperature Detector (URTD) input, Fiber optics interface, Versatile Link
- X103** – IEC 60870-5-103 / Modbus RTU / DNP3.0 RTU, RS485, Terminals
- X104** – IRIG-B00X, incl. System Contact (Supervision Contact)

# MRMV4-2C0AIB

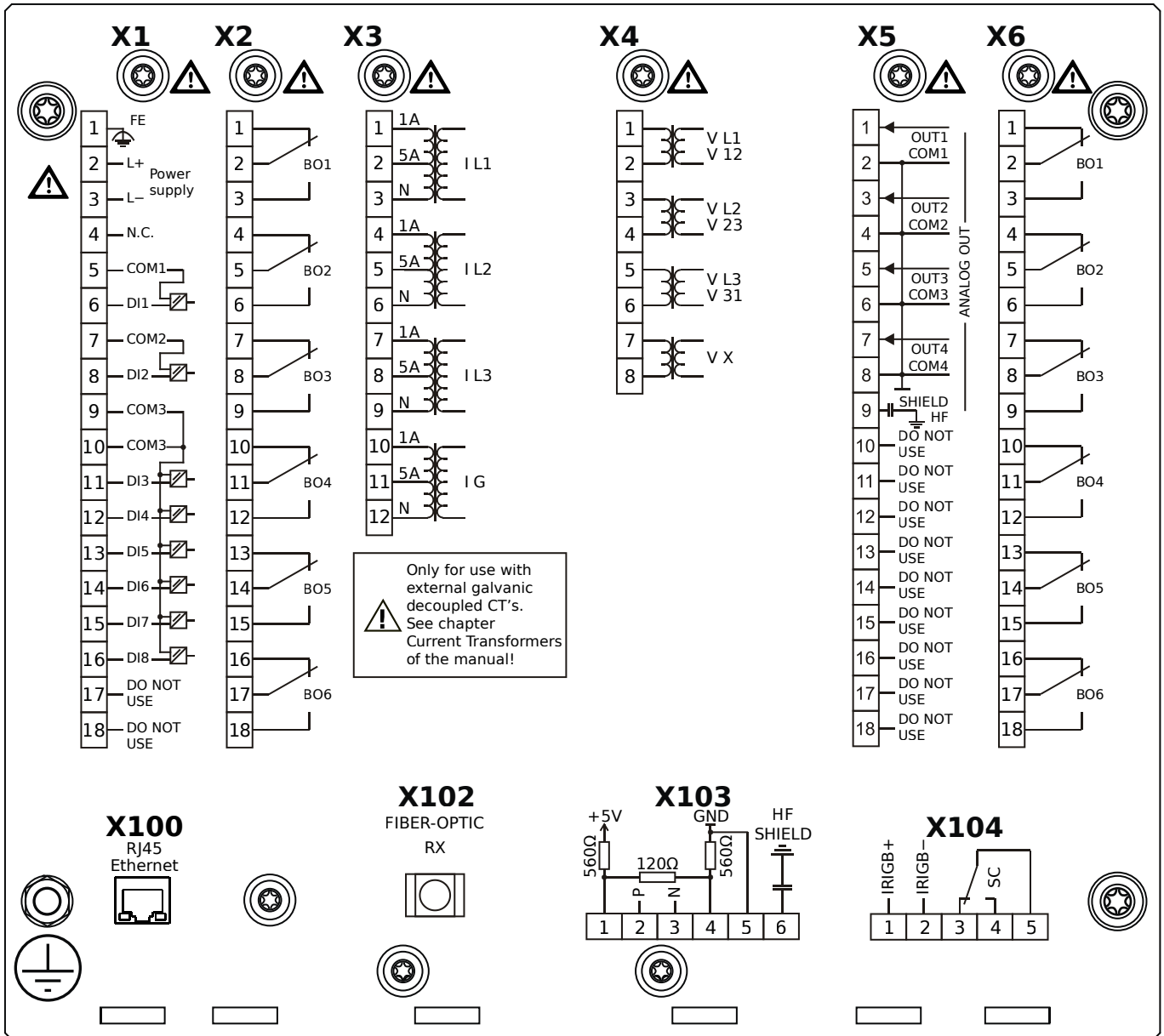

## Housing B2, small display, door mounting

+ Conformal Coating (for installations in harsh environment)

- X1** – DI8-X1: Wide-range power supply unit, incl. 2 non-grouped digital inputs and 6 grouped digital inputs
- X2** – OR6: Assembly Group with 6 Output Relays (Changeover / Form C)
- X3** – TI: Standard current measuring card
- X4** – TU: Card with 4 voltage transformer measuring inputs (0 ... 800 VAC, under UL: 0 ... 600 VAC)
- X5** – AnO4: Analog Outputs
- X6** – OR6: Assembly Group with 6 Output Relays (Changeover / Form C)
- X100** – Modbus TCP / IEC 60870-5-104 / DNP3.0 TCP/UDP, Ethernet interface, 100 Mbit/s, RJ45 (BASE100-FX)
- X102** – Universal Resistance-Temperature Detector (URTD) input, Fiber optics interface, Versatile Link
- X103** – IEC 60870-5-103 / Modbus RTU / DNP3.0 RTU, RS485, Terminals
- X104** – IRIG-B00X, incl. System Contact (Supervision Contact)

# MRMV4-2C0AKA

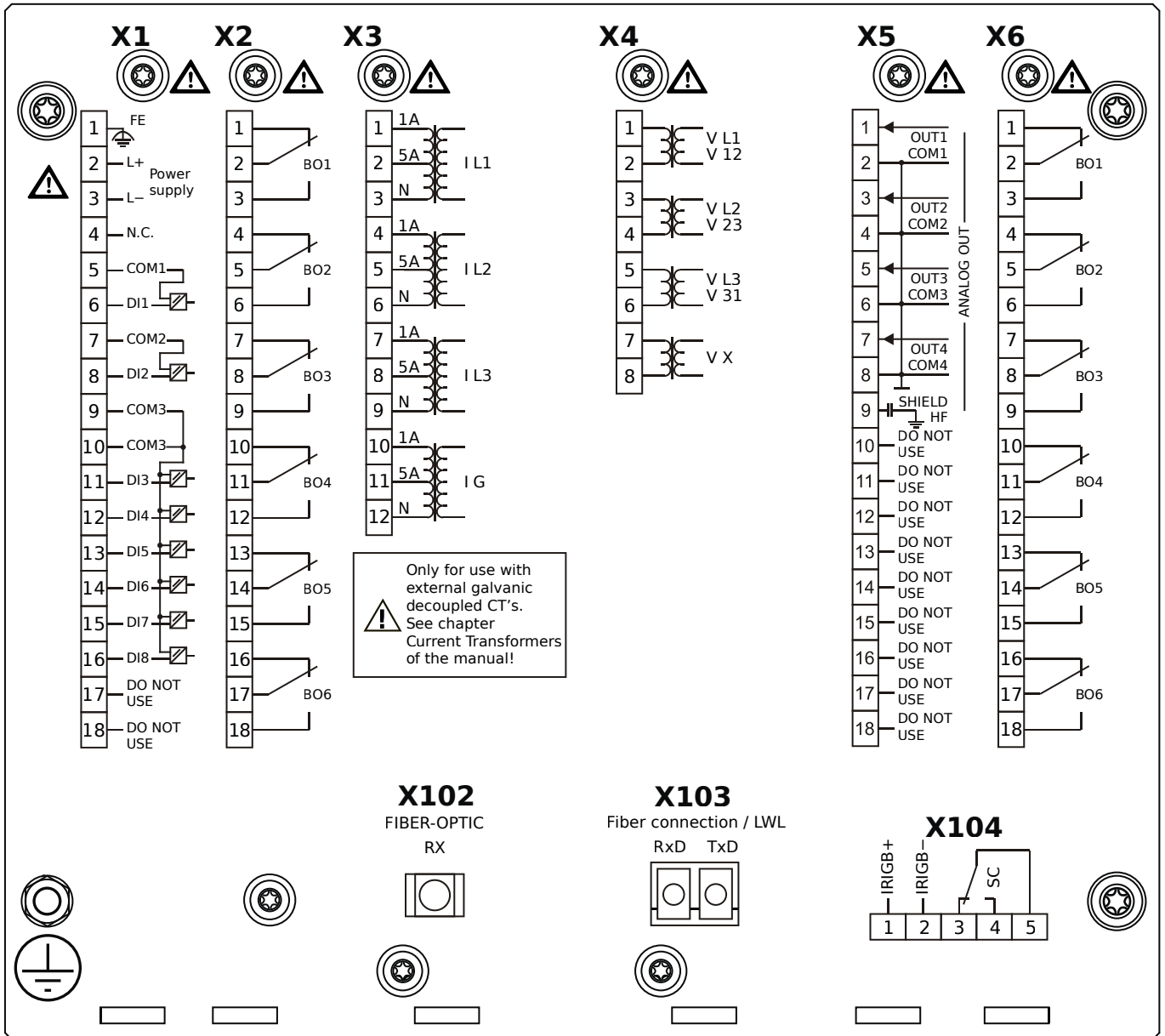

## Housing B2, small display, door mounting

- X1** – DI8-X1: Wide-range power supply unit, incl. 2 non-grouped digital inputs and 6 grouped digital inputs
- X2** – OR6: Assembly Group with 6 Output Relays (Changeover / Form C)
- X3** – TI: Standard current measuring card
- X4** – TU: Card with 4 voltage transformer measuring inputs (0 ... 800 VAC, under UL: 0 ... 600 VAC)
- X5** – AnO4: Analog Outputs
- X6** – OR6: Assembly Group with 6 Output Relays (Changeover / Form C)
- X102** – Universal Resistance-Temperature Detector (URTD) input, Fiber optics interface, Versatile Link
- X103** – IEC 61850 / Modbus TCP / IEC 60870-5-104 / DNP3.0 TCP/UDP, Fiber optics interface, LC Connector
- X104** – IRIG-B00X, incl. System Contact (Supervision Contact)

# MRMV4-2C0AKB

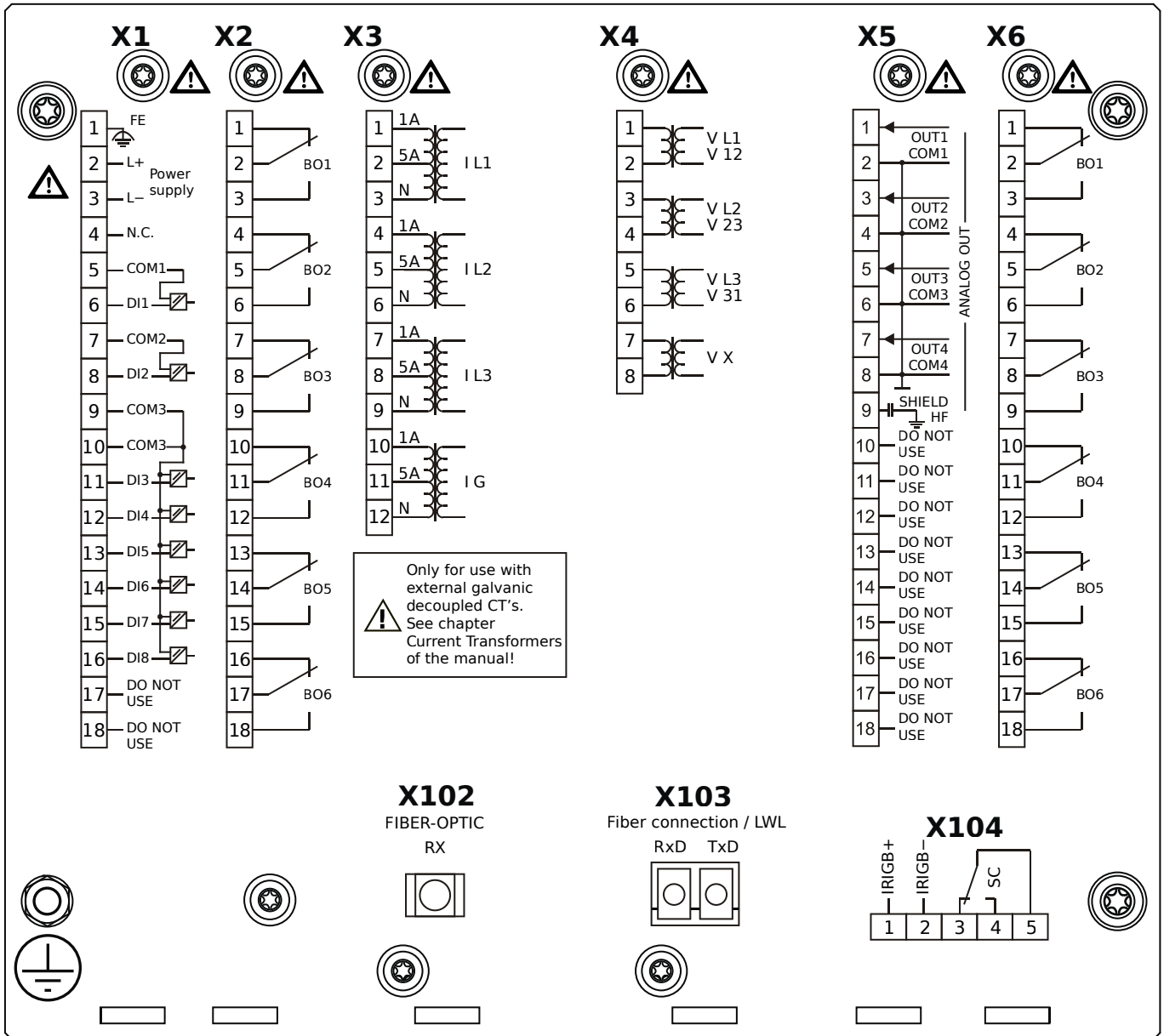

## Housing B2, small display, door mounting

+ Conformal Coating (for installations in harsh environment)

- X1** – DI8-X1: Wide-range power supply unit, incl. 2 non-grouped digital inputs and 6 grouped digital inputs
- X2** – OR6: Assembly Group with 6 Output Relays (Changeover / Form C)
- X3** – TI: Standard current measuring card
- X4** – TU: Card with 4 voltage transformer measuring inputs (0 ... 800 VAC, under UL: 0 ... 600 VAC)
- X5** – AnO4: Analog Outputs
- X6** – OR6: Assembly Group with 6 Output Relays (Changeover / Form C)
- X102** – Universal Resistance-Temperature Detector (URTD) input, Fiber optics interface, Versatile Link
- X103** – IEC 61850 / Modbus TCP / IEC 60870-5-104 / DNP3.0 TCP/UDP, Fiber optics interface, LC Connector
- X104** – IRIG-B00X, incl. System Contact (Supervision Contact)

# MRMV4-2C0ALA

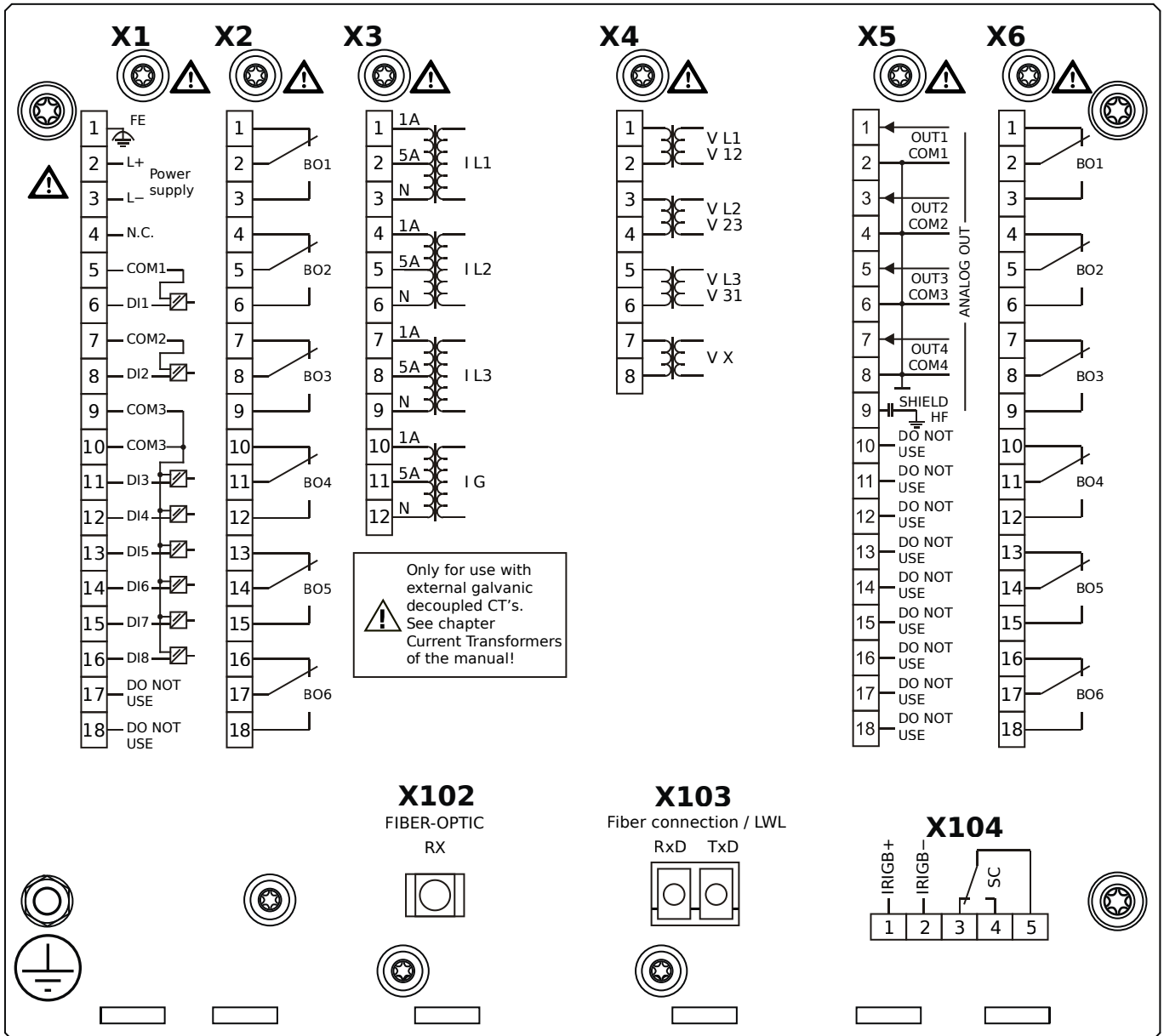

## Housing B2, small display, door mounting

- X1** – DI8-X1: Wide-range power supply unit, incl. 2 non-grouped digital inputs and 6 grouped digital inputs
- X2** – OR6: Assembly Group with 6 Output Relays (Changeover / Form C)
- X3** – TI: Standard current measuring card
- X4** – TU: Card with 4 voltage transformer measuring inputs (0 ... 800 VAC, under UL: 0 ... 600 VAC)
- X5** – AnO4: Analog Outputs
- X6** – OR6: Assembly Group with 6 Output Relays (Changeover / Form C)
- X102** – Universal Resistance-Temperature Detector (URTD) input, Fiber optics interface, Versatile Link
- X103** – Modbus TCP / IEC 60870-5-104 / DNP3.0 TCP/UDP, Fiber optics interface, LC Connector
- X104** – IRIG-B00X, incl. System Contact (Supervision Contact)

# MRMV4-2C0ALB

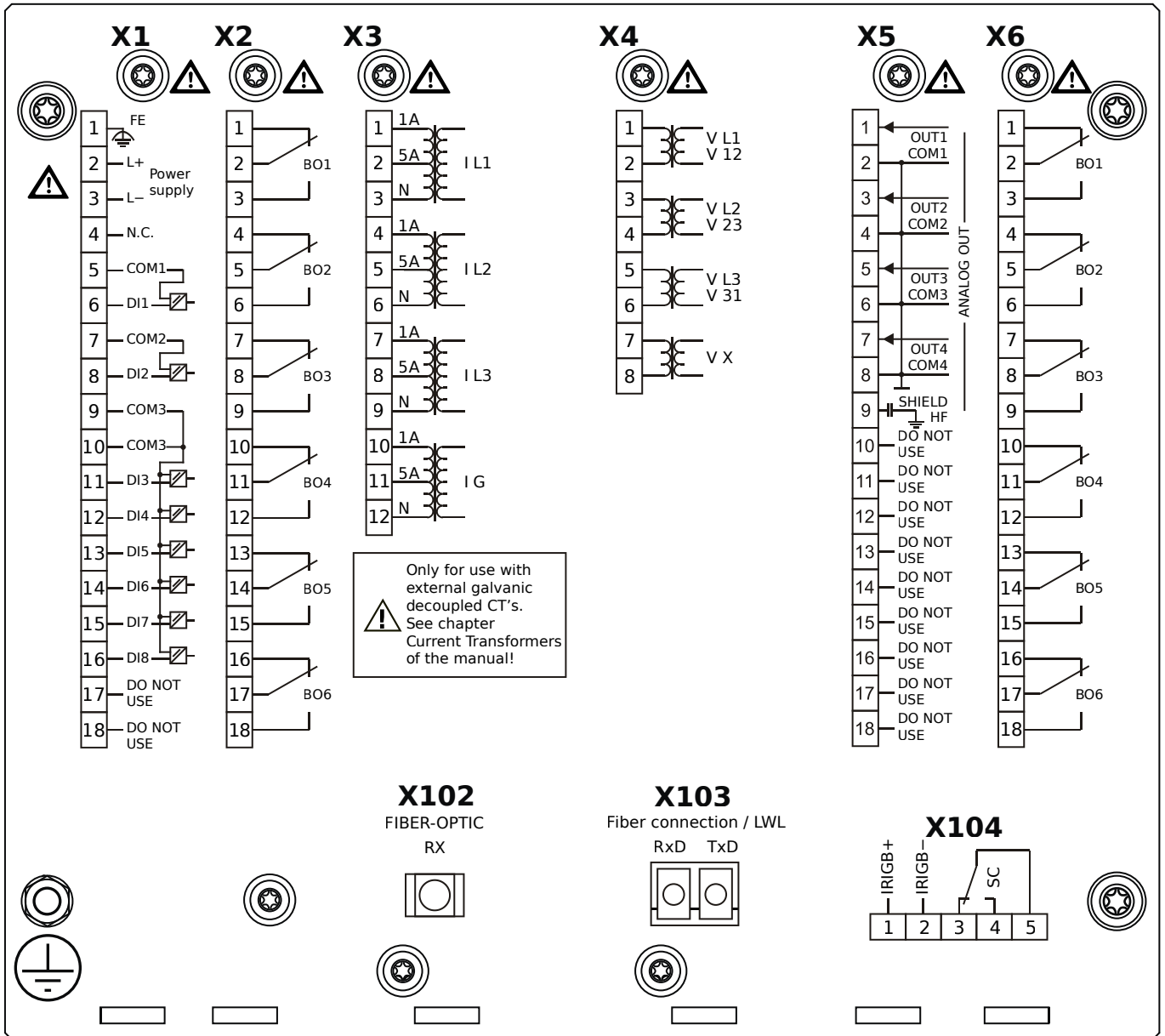

## Housing B2, small display, door mounting

+ Conformal Coating (for installations in harsh environment)

- X1** – DI8-X1: Wide-range power supply unit, incl. 2 non-grouped digital inputs and 6 grouped digital inputs
- X2** – OR6: Assembly Group with 6 Output Relays (Changeover / Form C)
- X3** – TI: Standard current measuring card
- X4** – TU: Card with 4 voltage transformer measuring inputs (0 ... 800 VAC, under UL: 0 ... 600 VAC)
- X5** – AnO4: Analog Outputs
- X6** – OR6: Assembly Group with 6 Output Relays (Changeover / Form C)
- X102** – Universal Resistance-Temperature Detector (URTD) input, Fiber optics interface, Versatile Link
- X103** – Modbus TCP / IEC 60870-5-104 / DNP3.0 TCP/UDP, Fiber optics interface, LC Connector
- X104** – IRIG-B00X, incl. System Contact (Supervision Contact)

# MRMV4-2C0AOA

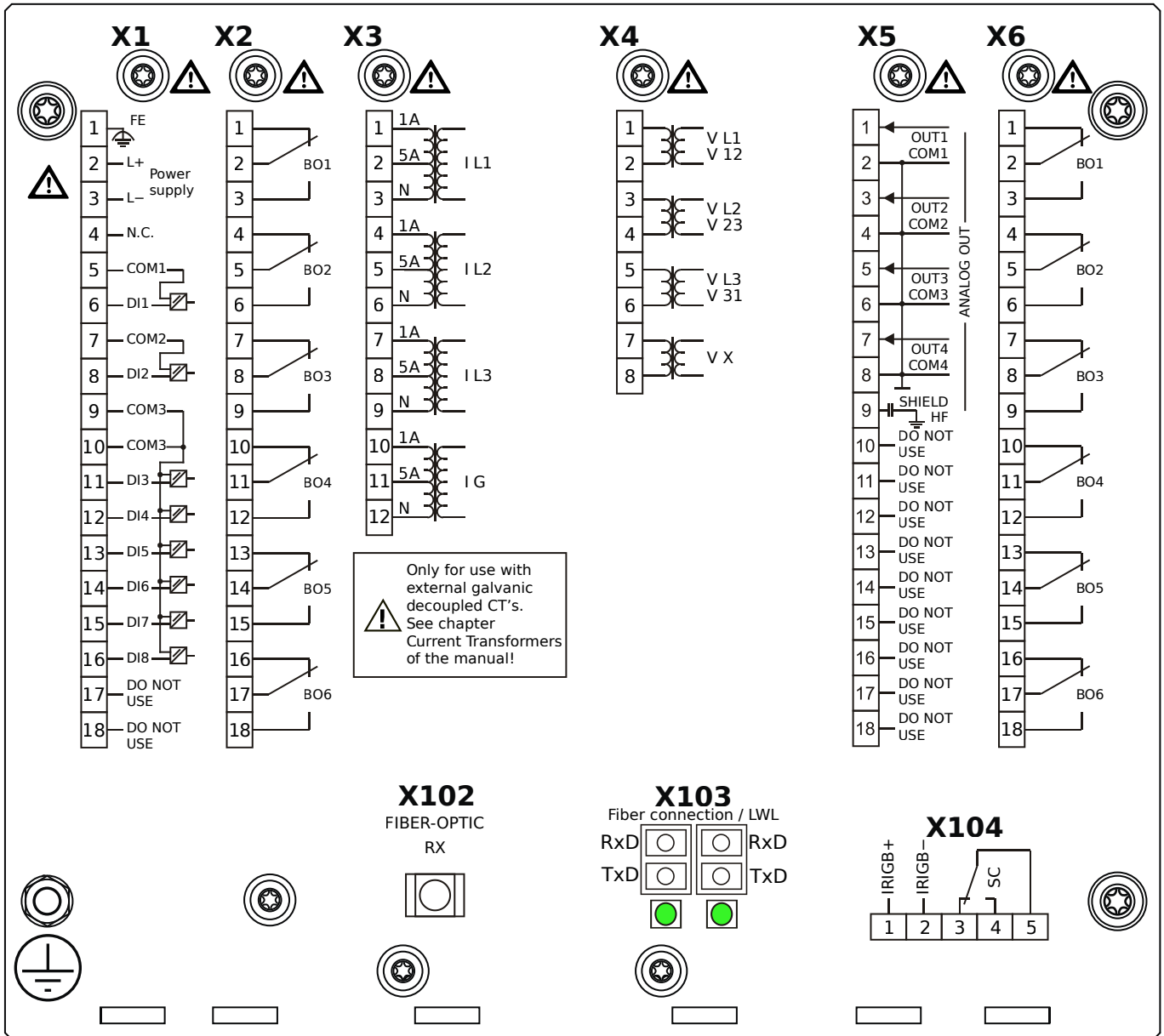

## Housing B2, small display, door mounting

- X1** – DI8-X1: Wide-range power supply unit, incl. 2 non-grouped digital inputs and 6 grouped digital inputs
- X2** – OR6: Assembly Group with 6 Output Relays (Changeover / Form C)
- X3** – TI: Standard current measuring card
- X4** – TU: Card with 4 voltage transformer measuring inputs (0 ... 800 VAC, under UL: 0 ... 600 VAC)
- X5** – AnO4: Analog Outputs
- X6** – OR6: Assembly Group with 6 Output Relays (Changeover / Form C)
- X102** – Universal Resistance-Temperature Detector (URTD) input, Fiber optics interface, Versatile Link
- X103** – Modbus TCP / IEC 60870-5-104 / DNP3.0 TCP/UDP, Redundant Fiber optics interface, LC Connector
- X104** – IRIG-B00X, incl. System Contact (Supervision Contact)



# MRMV4-2C0AOB

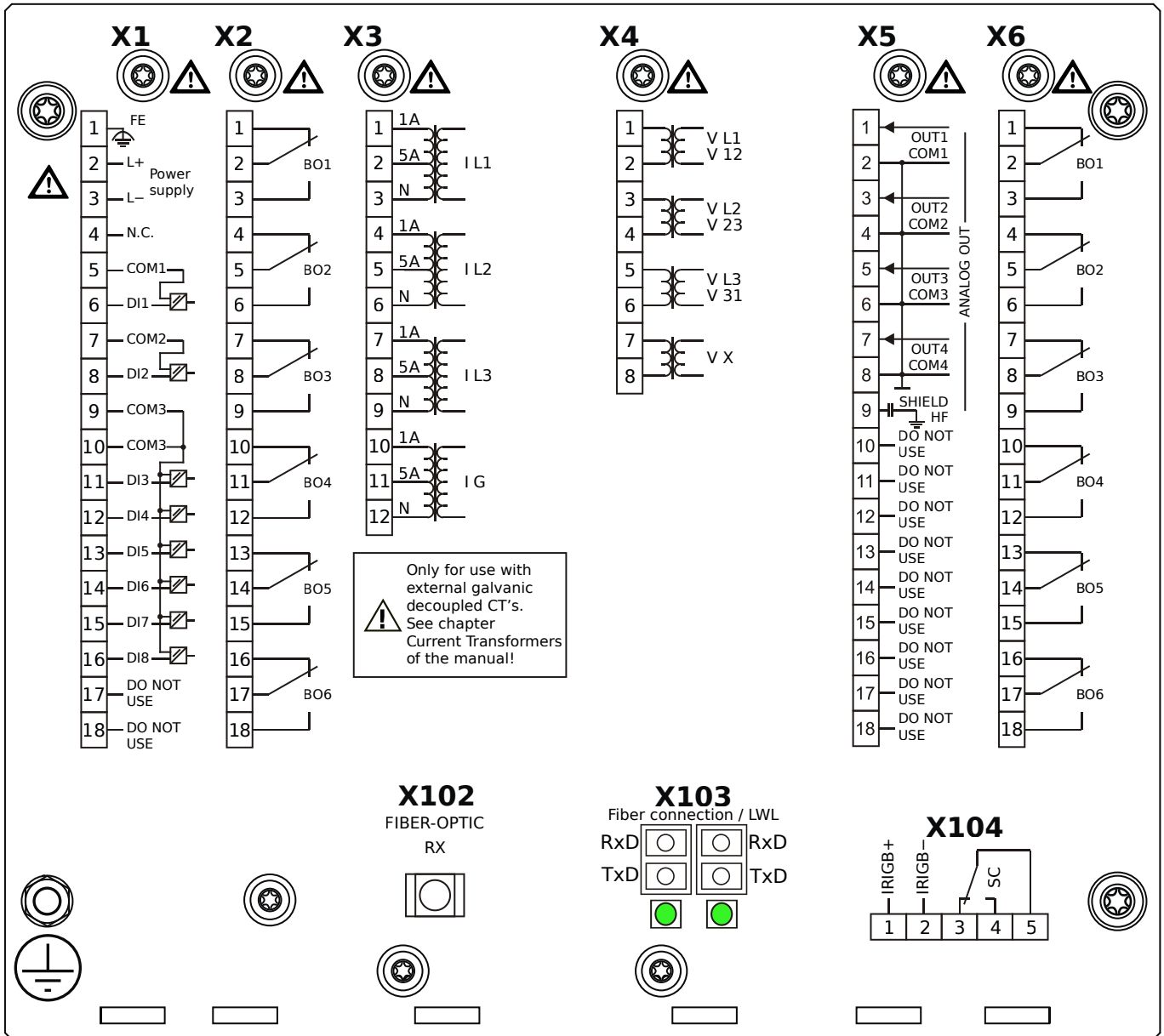

## Housing B2, small display, door mounting

- + Conformal Coating (for installations in harsh environment)

- X1** – DI8-X1: Wide-range power supply unit, incl. 2 non-grouped digital inputs and 6 grouped digital inputs
- X2** – OR6: Assembly Group with 6 Output Relays (Changeover / Form C)
- X3** – TI: Standard current measuring card
- X4** – TU: Card with 4 voltage transformer measuring inputs (0 ... 800 VAC, under UL: 0 ... 600 VAC)
- X5** – AnO4: Analog Outputs
- X6** – OR6: Assembly Group with 6 Output Relays (Changeover / Form C)
- X102** – Universal Resistance-Temperature Detector (URTD) input, Fiber optics interface, Versatile Link
- X103** – Modbus TCP / IEC 60870-5-104 / DNP3.0 TCP/UDP, Redundant Fiber optics interface, LC Connector
- X104** – IRIG-B00X, incl. System Contact (Supervision Contact)

# MRMV4-2C0APA

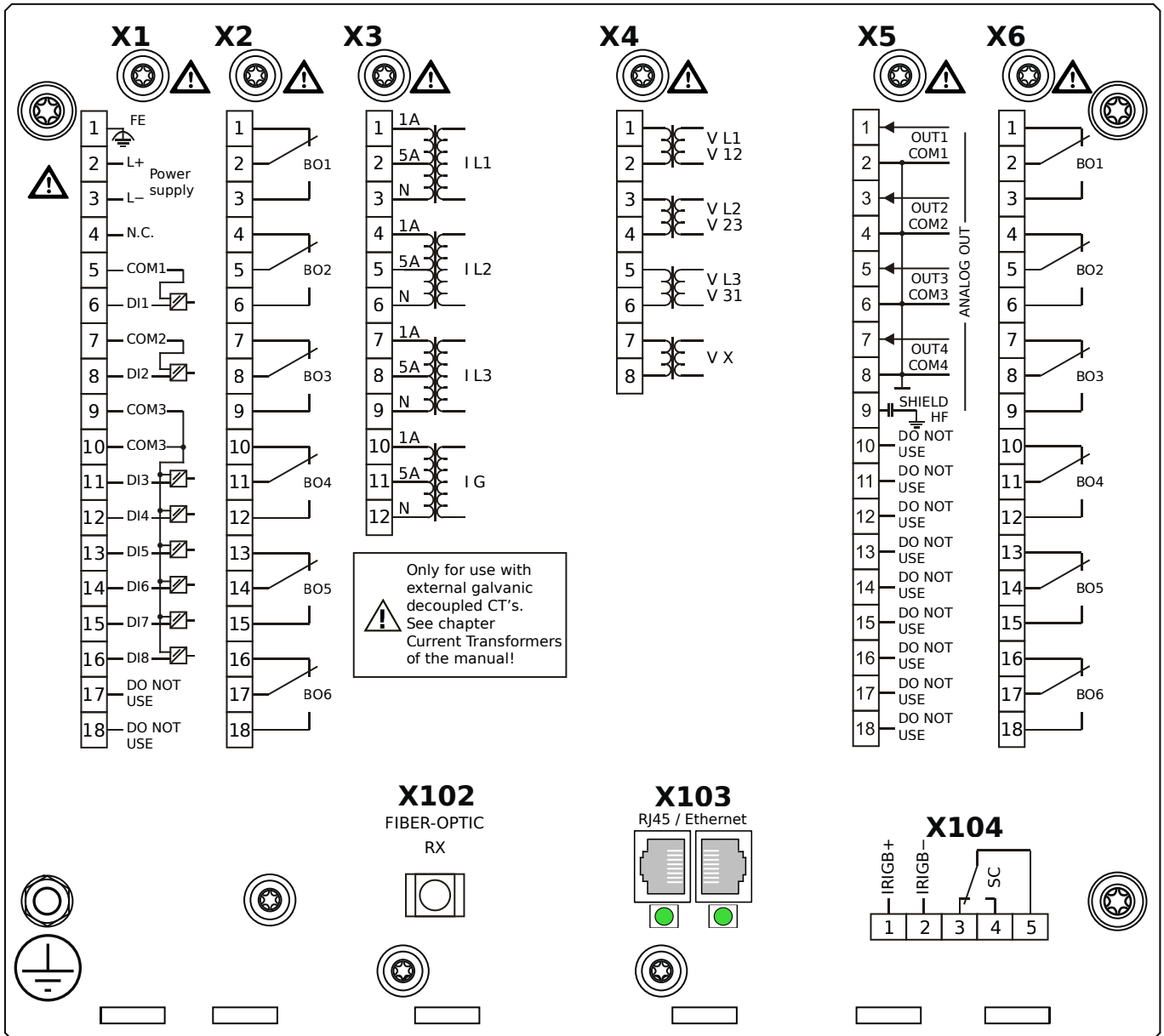

## Housing B2, small display, door mounting

- X1** – DI8-X1: Wide-range power supply unit, incl. 2 non-grouped digital inputs and 6 grouped digital inputs
- X2** – OR6: Assembly Group with 6 Output Relays (Changeover / Form C)
- X3** – TI: Standard current measuring card
- X4** – TU: Card with 4 voltage transformer measuring inputs (0 ... 800 VAC, under UL: 0 ... 600 VAC)
- X5** – AnO4: Analog Outputs
- X6** – OR6: Assembly Group with 6 Output Relays (Changeover / Form C)
- X102** – Universal Resistance-Temperature Detector (URTD) input, Fiber optics interface, Versatile Link
- X103** – Modbus TCP / IEC 60870-5-104 / DNP3.0 TCP/UDP, Redundant Ethernet interface, 100 Mbit/s, RJ45 (BASE100-FX)
- X104** – IRIG-B00X, incl. System Contact (Supervision Contact)

# MRMV4-2C0APB

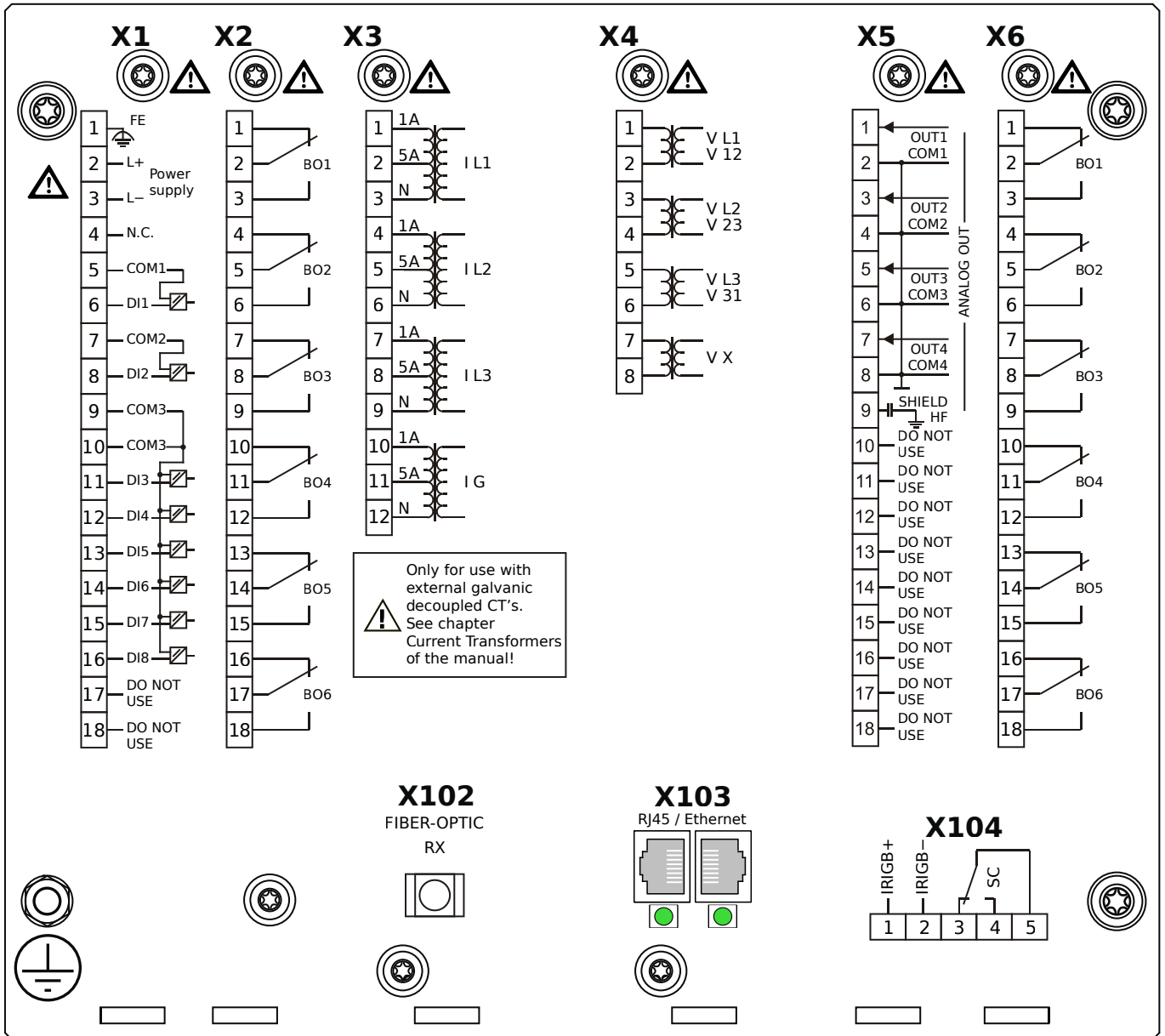

## Housing B2, small display, door mounting

- + Conformal Coating (for installations in harsh environment)

- X1** – DI8-X1: Wide-range power supply unit, incl. 2 non-grouped digital inputs and 6 grouped digital inputs
- X2** – OR6: Assembly Group with 6 Output Relays (Changeover / Form C)
- X3** – TI: Standard current measuring card
- X4** – TU: Card with 4 voltage transformer measuring inputs (0 ... 800 VAC, under UL: 0 ... 600 VAC)
- X5** – AnO4: Analog Outputs
- X6** – OR6: Assembly Group with 6 Output Relays (Changeover / Form C)
- X102** – Universal Resistance-Temperature Detector (URTD) input, Fiber optics interface, Versatile Link
- X103** – Modbus TCP / IEC 60870-5-104 / DNP3.0 TCP/UDP, Redundant Ethernet interface, 100 Mbit/s, RJ45 (BASE100-FX)
- X104** – IRIG-B00X, incl. System Contact (Supervision Contact)

# MRMV4-2C0AQA

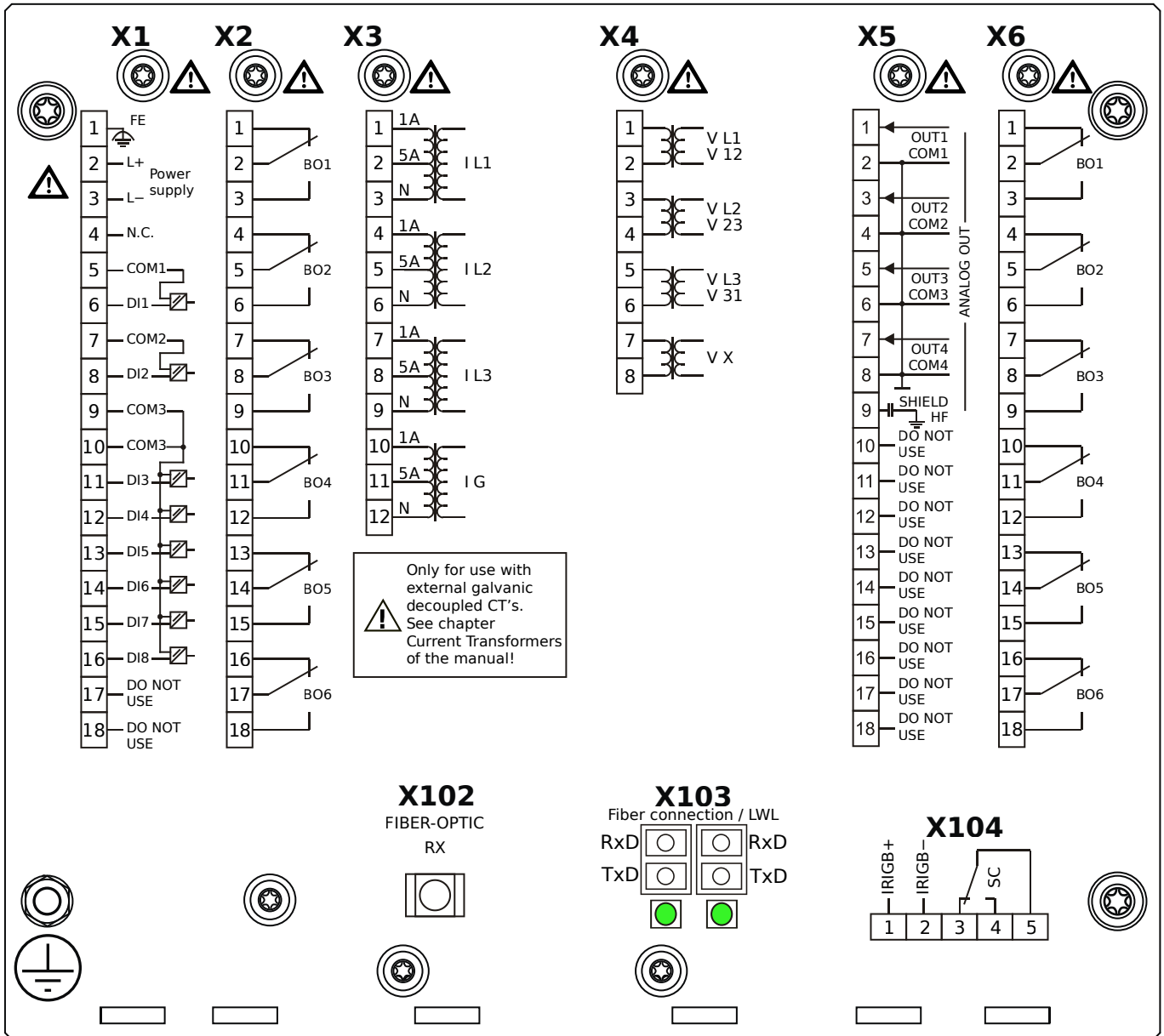

## Housing B2, small display, door mounting

- X1** – DI8-X1: Wide-range power supply unit, incl. 2 non-grouped digital inputs and 6 grouped digital inputs
- X2** – OR6: Assembly Group with 6 Output Relays (Changeover / Form C)
- X3** – TI: Standard current measuring card
- X4** – TU: Card with 4 voltage transformer measuring inputs (0 ... 800 VAC, under UL: 0 ... 600 VAC)
- X5** – AnO4: Analog Outputs
- X6** – OR6: Assembly Group with 6 Output Relays (Changeover / Form C)
- X102** – Universal Resistance-Temperature Detector (URTD) input, Fiber optics interface, Versatile Link
- X103** – IEC 61850 / Modbus TCP / IEC 60870-5-104 / DNP3.0 TCP/UDP, Redundant Fiber optics interface, LC Connector
- X104** – IRIG-B00X, incl. System Contact (Supervision Contact)

# MRMV4-2C0AQB

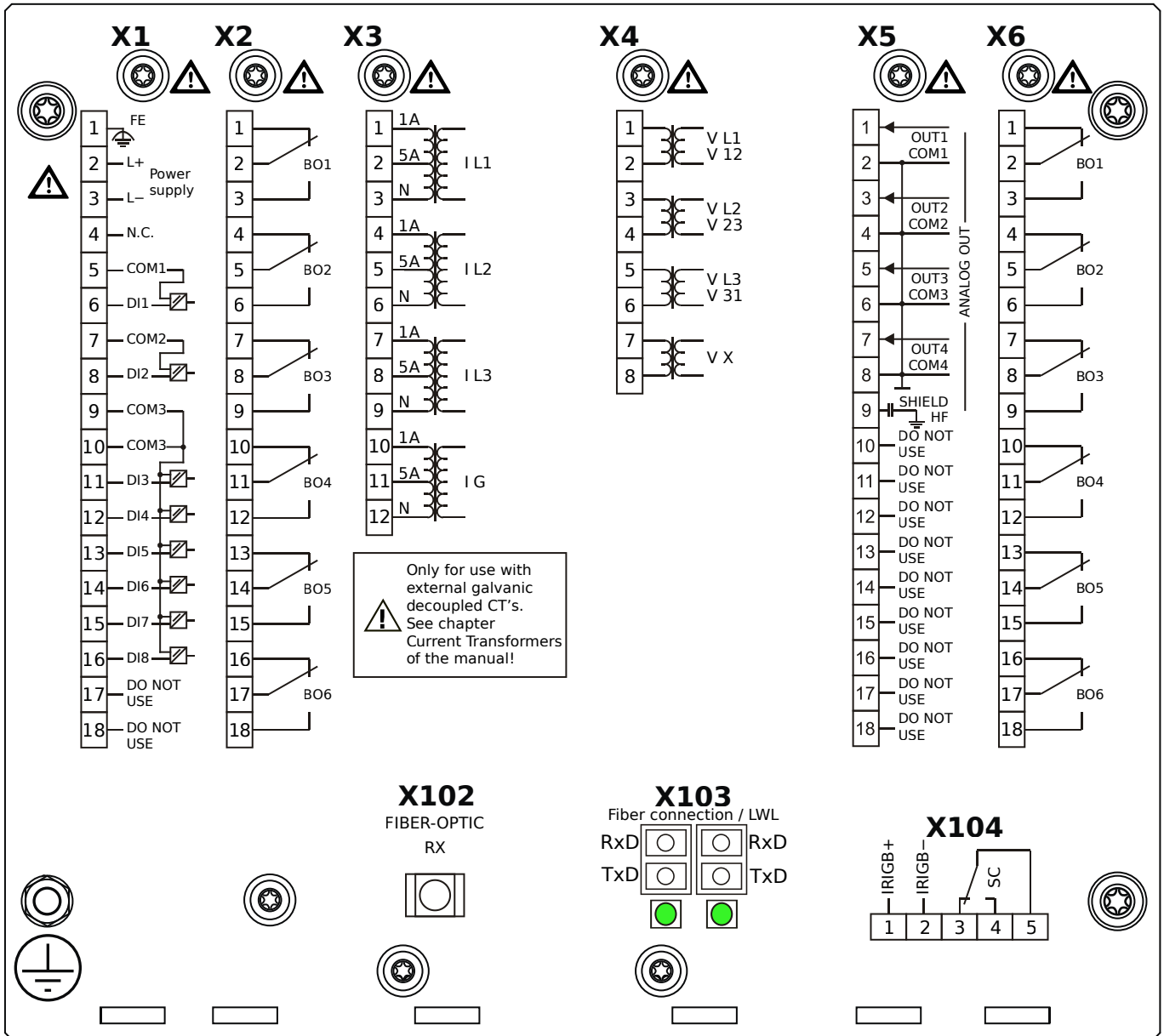

## Housing B2, small display, door mounting

- + Conformal Coating (for installations in harsh environment)

- X1** – DI8-X1: Wide-range power supply unit, incl. 2 non-grouped digital inputs and 6 grouped digital inputs
- X2** – OR6: Assembly Group with 6 Output Relays (Changeover / Form C)
- X3** – TI: Standard current measuring card
- X4** – TU: Card with 4 voltage transformer measuring inputs (0 ... 800 VAC, under UL: 0 ... 600 VAC)
- X5** – AnO4: Analog Outputs
- X6** – OR6: Assembly Group with 6 Output Relays (Changeover / Form C)
- X102** – Universal Resistance-Temperature Detector (URTD) input, Fiber optics interface, Versatile Link
- X103** – IEC 61850 / Modbus TCP / IEC 60870-5-104 / DNP3.0 TCP/UDP, Redundant Fiber optics interface, LC Connector
- X104** – IRIG-B00X, incl. System Contact (Supervision Contact)

# MRMV4-2C0ARA

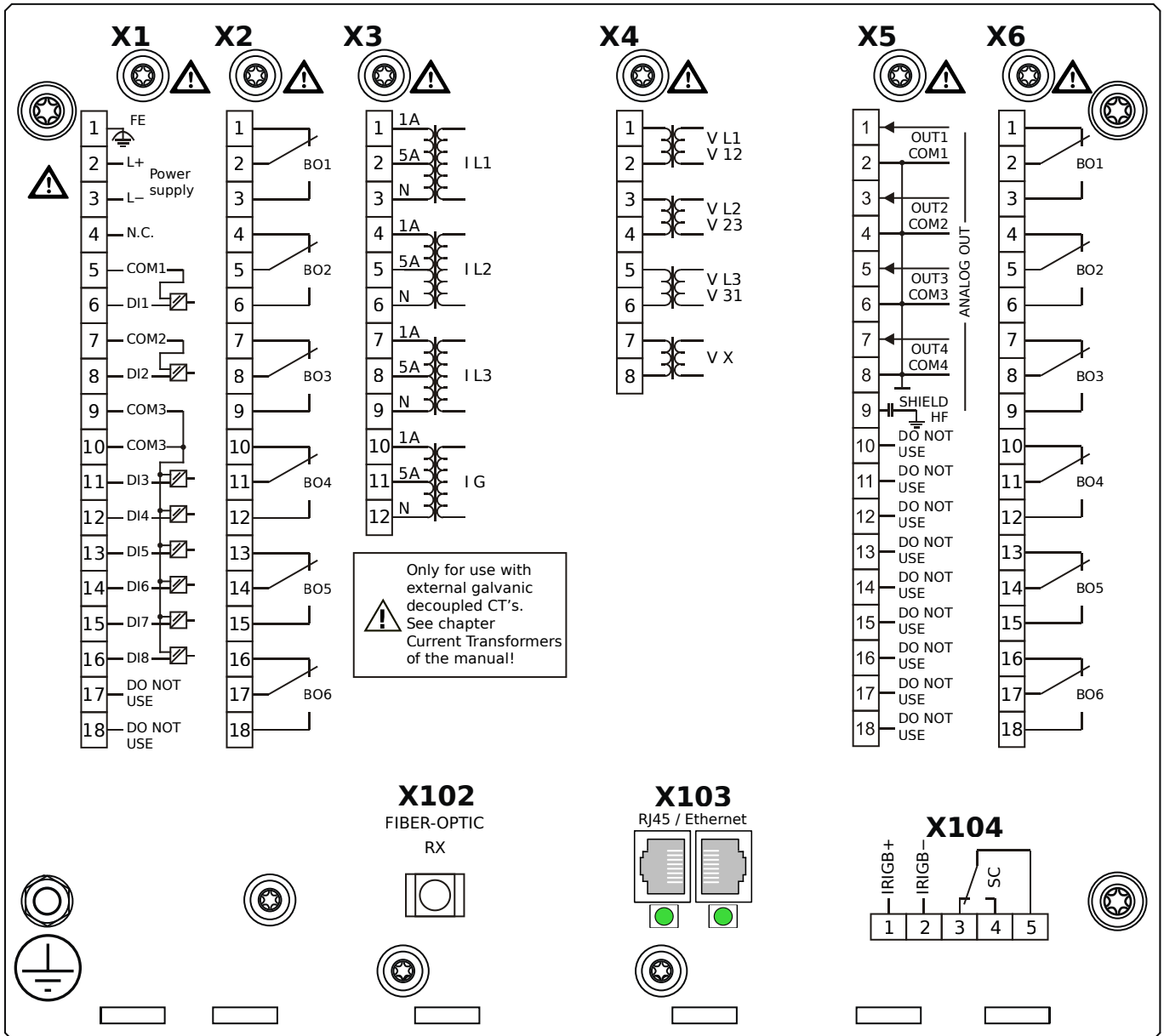

## Housing B2, small display, door mounting

- X1** – DI8-X1: Wide-range power supply unit, incl. 2 non-grouped digital inputs and 6 grouped digital inputs
- X2** – OR6: Assembly Group with 6 Output Relays (Changeover / Form C)
- X3** – TI: Standard current measuring card
- X4** – TU: Card with 4 voltage transformer measuring inputs (0 ... 800 VAC, under UL: 0 ... 600 VAC)
- X5** – AnO4: Analog Outputs
- X6** – OR6: Assembly Group with 6 Output Relays (Changeover / Form C)
- X102** – Universal Resistance-Temperature Detector (URTD) input, Fiber optics interface, Versatile Link
- X103** – IEC 61850 / Modbus TCP / IEC 60870-5-104 / DNP3.0 TCP/UDP, Redundant Ethernet interface, 100 Mbit/s, RJ45
- X104** – IRIG-B00X, incl. System Contact (Supervision Contact)

# MRMV4-2C0ARB

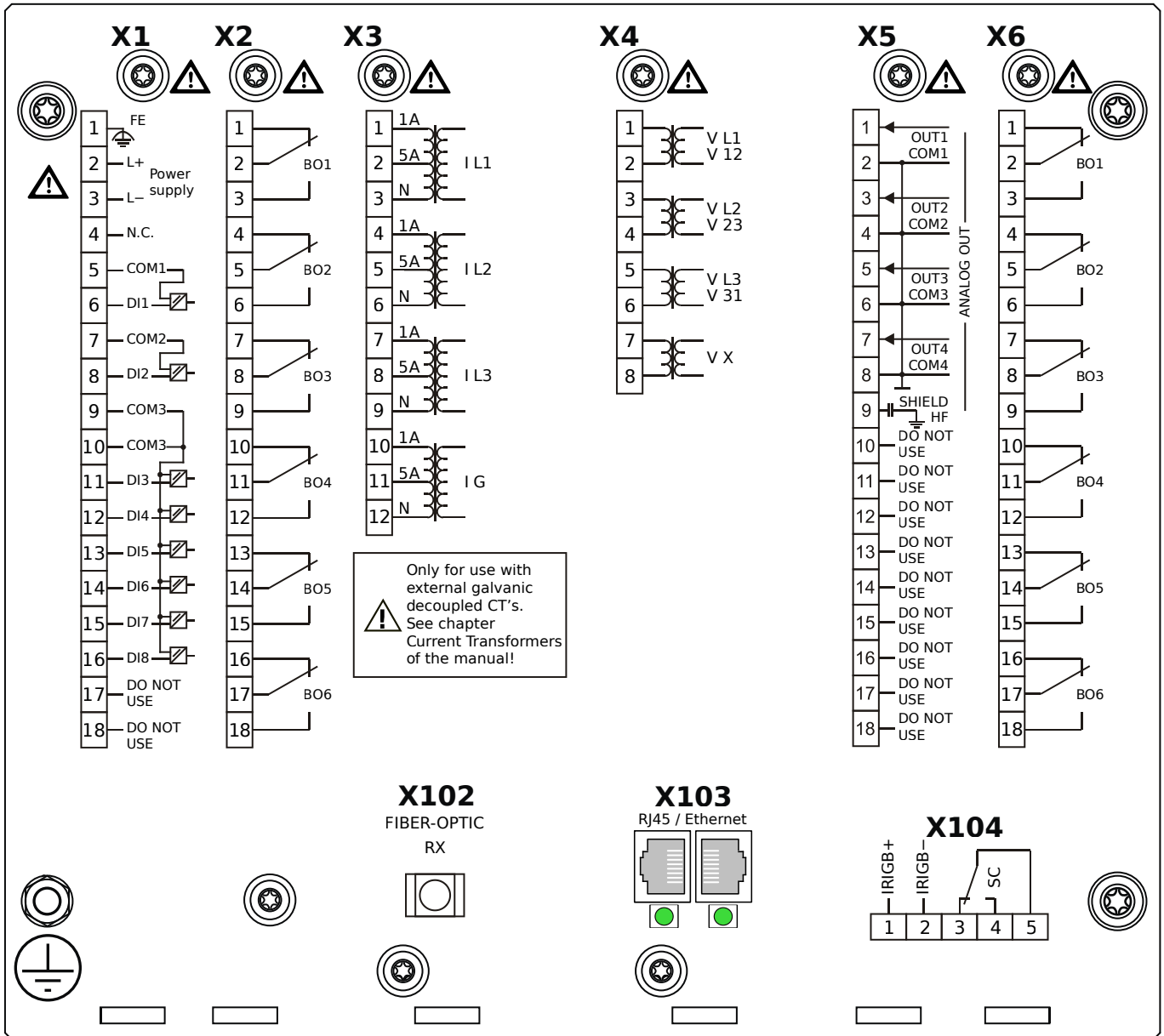

## Housing B2, small display, door mounting

+ Conformal Coating (for installations in harsh environment)

**X1** – DI8-X1: Wide-range power supply unit, incl. 2 non-grouped digital inputs and 6 grouped digital inputs

**X2** – OR6: Assembly Group with 6 Output Relays (Changeover / Form C)

**X3** – TI: Standard current measuring card

**X4** – TU: Card with 4 voltage transformer measuring inputs (0 ... 800 VAC, under UL: 0 ... 600 VAC)

**X5** – AnO4: Analog Outputs

**X6** – OR6: Assembly Group with 6 Output Relays (Changeover / Form C)

**X102** – Universal Resistance-Temperature Detector (URTD) input, Fiber optics interface, Versatile Link

**X103** – IEC 61850 / Modbus TCP / IEC 60870-5-104 / DNP3.0 TCP/UDP, Redundant Ethernet interface, 100 Mbit/s, RJ45

(BASE100-FX)

**X104** – IRIG-B00X, incl. System Contact (Supervision Contact)

# MRMV4-2C0ATA

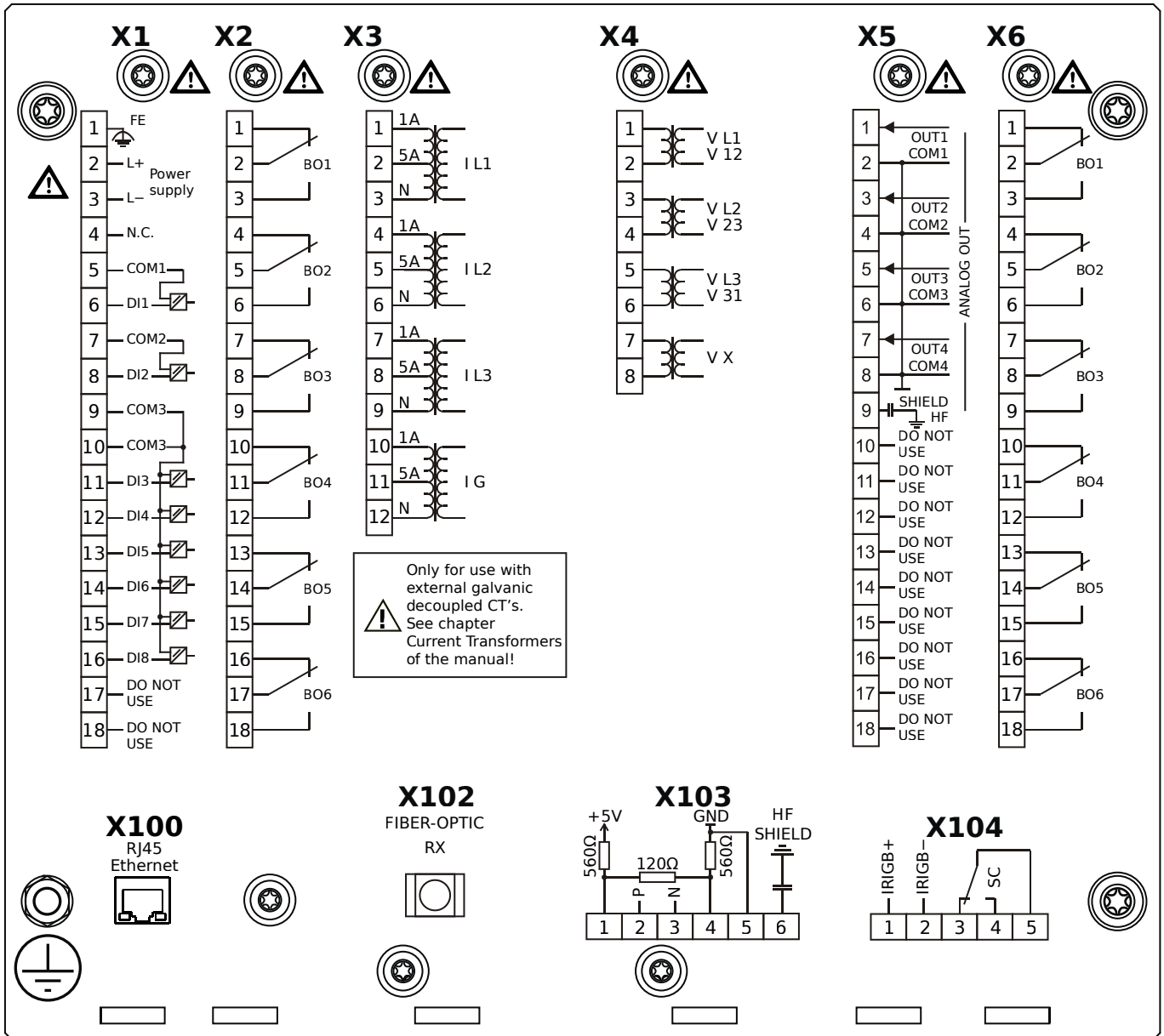

## Housing B2, small display, door mounting

- X1** – DI8-X1: Wide-range power supply unit, incl. 2 non-grouped digital inputs and 6 grouped digital inputs
- X2** – OR6: Assembly Group with 6 Output Relays (Changeover / Form C)
- X3** – TI: Standard current measuring card
- X4** – TU: Card with 4 voltage transformer measuring inputs (0 ... 800 VAC, under UL: 0 ... 600 VAC)
- X5** – AnO4: Analog Outputs
- X6** – OR6: Assembly Group with 6 Output Relays (Changeover / Form C)
- X100** – IEC 61850 / Modbus TCP / IEC 60870-5-104 / DNP3.0 TCP/UDP, Ethernet interface, 100 Mbit/s, RJ45 (BASE100-FX)
- X102** – Universal Resistance-Temperature Detector (URTD) input, Fiber optics interface, Versatile Link
- X103** – IEC 60870-5-103 / Modbus RTU / DNP3.0 RTU, RS485, Terminals
- X104** – IRIG-B00X, incl. System Contact (Supervision Contact)



# MRMV4-2C0ATB

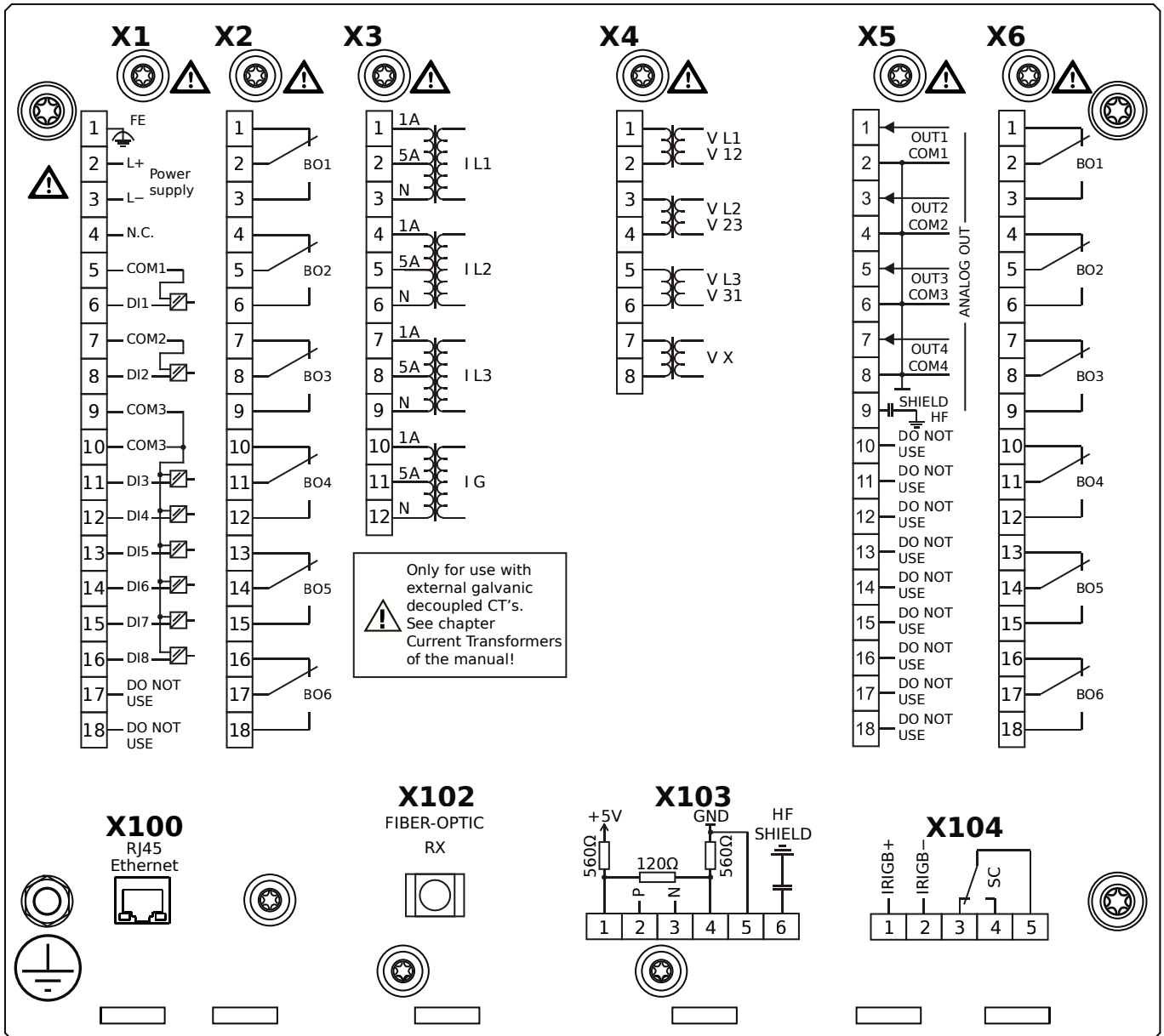

## Housing B2, small display, door mounting

+ Conformal Coating (for installations in harsh environment)

**X1** – DI8-X1: Wide-range power supply unit, incl. 2 non-grouped digital inputs and 6 grouped digital inputs

**X2** – OR6: Assembly Group with 6 Output Relays (Changeover / Form C)

**X3** – TI: Standard current measuring card

**X4** – TU: Card with 4 voltage transformer measuring inputs (0 ... 800 VAC, under UL: 0 ... 600 VAC)

**X5** – AnO4: Analog Outputs

**X6** – OR6: Assembly Group with 6 Output Relays (Changeover / Form C)

**X100** – IEC 61850 / Modbus TCP / IEC 60870-5-104 / DNP3.0 TCP/UDP, Ethernet interface, 100 Mbit/s, RJ45 (BASE100-

FX)

**X102** – Universal Resistance-Temperature Detector (URTD) input, Fiber optics interface, Versatile Link

**X103** – IEC 60870-5-103 / Modbus RTU / DNP3.0 RTU, RS485, Terminals

**X104** – IRIG-B00X, incl. System Contact (Supervision Contact)

# MRMV4-2C0BAA

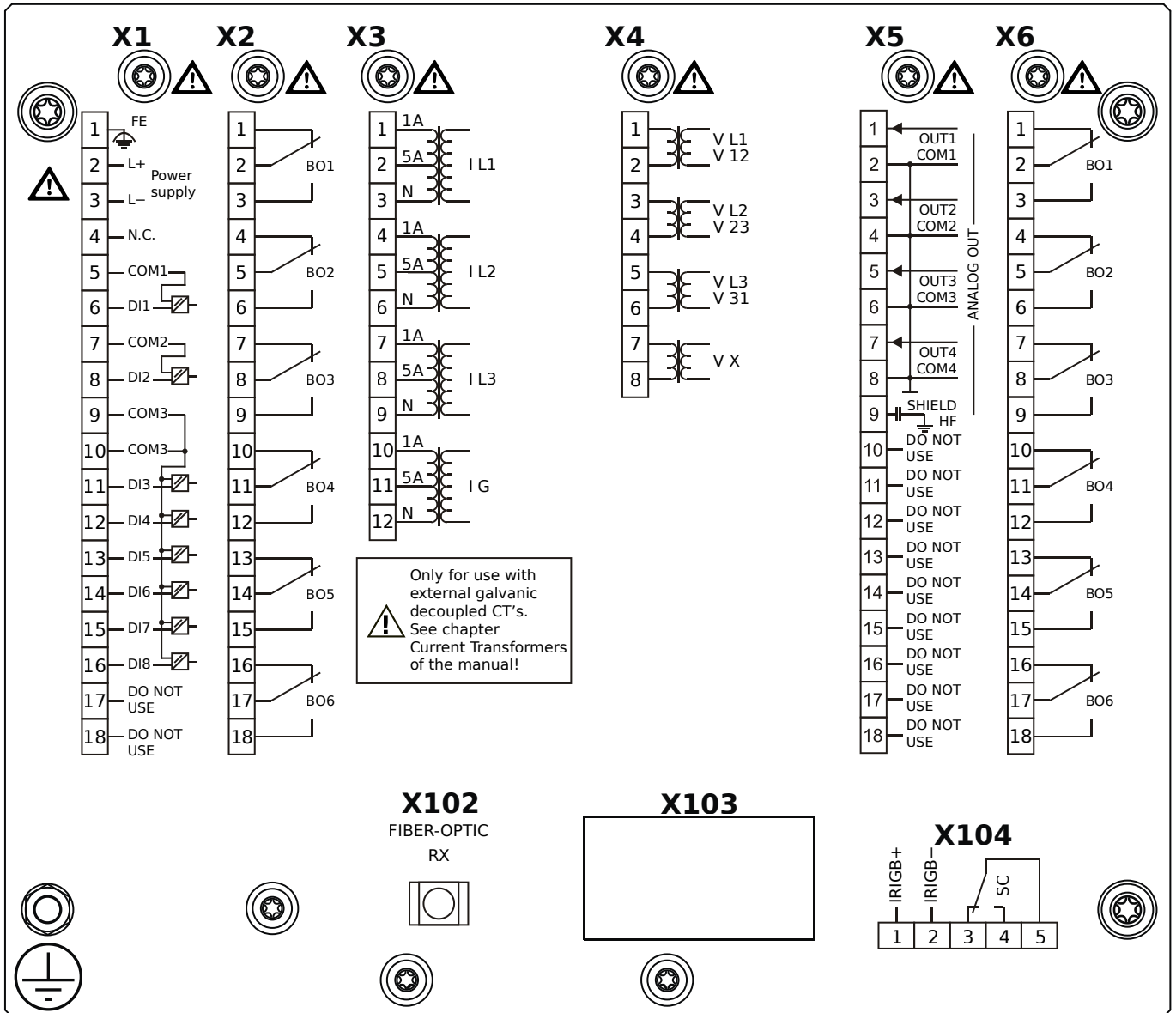

## Housing B2, small display, 19" rack mounting

- X1** – DI8-X1: Wide-range power supply unit, incl. 2 non-grouped digital inputs and 6 grouped digital inputs
- X2** – OR6: Assembly Group with 6 Output Relays (Changeover / Form C)
- X3** – TI: Standard current measuring card
- X4** – TU: Card with 4 voltage transformer measuring inputs (0 ... 800 VAC, under UL: 0 ... 600 VAC)
- X5** – AnO4: Analog Outputs
- X6** – OR6: Assembly Group with 6 Output Relays (Changeover / Form C)
- X102** – Universal Resistance-Temperature Detector (URTD) input, Fiber optics interface, Versatile Link
- X104** – IRIG-B00X, incl. System Contact (Supervision Contact)

# MRMV4-2C0BAB

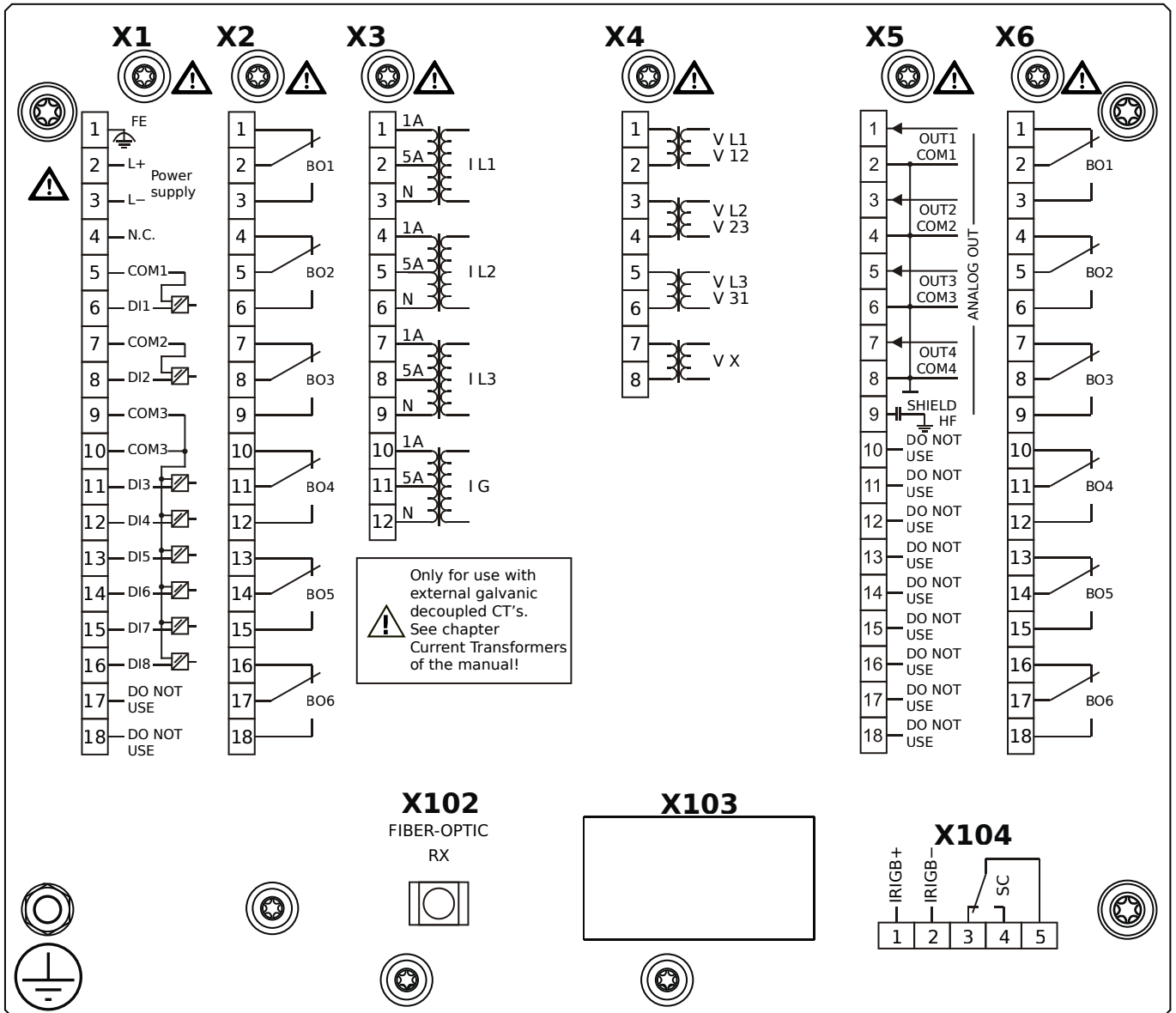

## Housing B2, small display, 19" rack mounting

+ Conformal Coating (for installations in harsh environment)

- X1** – DI8-X1: Wide-range power supply unit, incl. 2 non-grouped digital inputs and 6 grouped digital inputs
- X2** – OR6: Assembly Group with 6 Output Relays (Changeover / Form C)
- X3** – TI: Standard current measuring card
- X4** – TU: Card with 4 voltage transformer measuring inputs (0 ... 800 VAC, under UL: 0 ... 600 VAC)
- X5** – AnO4: Analog Outputs
- X6** – OR6: Assembly Group with 6 Output Relays (Changeover / Form C)
- X102** – Universal Resistance-Temperature Detector (URTD) input, Fiber optics interface, Versatile Link
- X104** – IRIG-B00X, incl. System Contact (Supervision Contact)

# MRMV4-2C0BBA

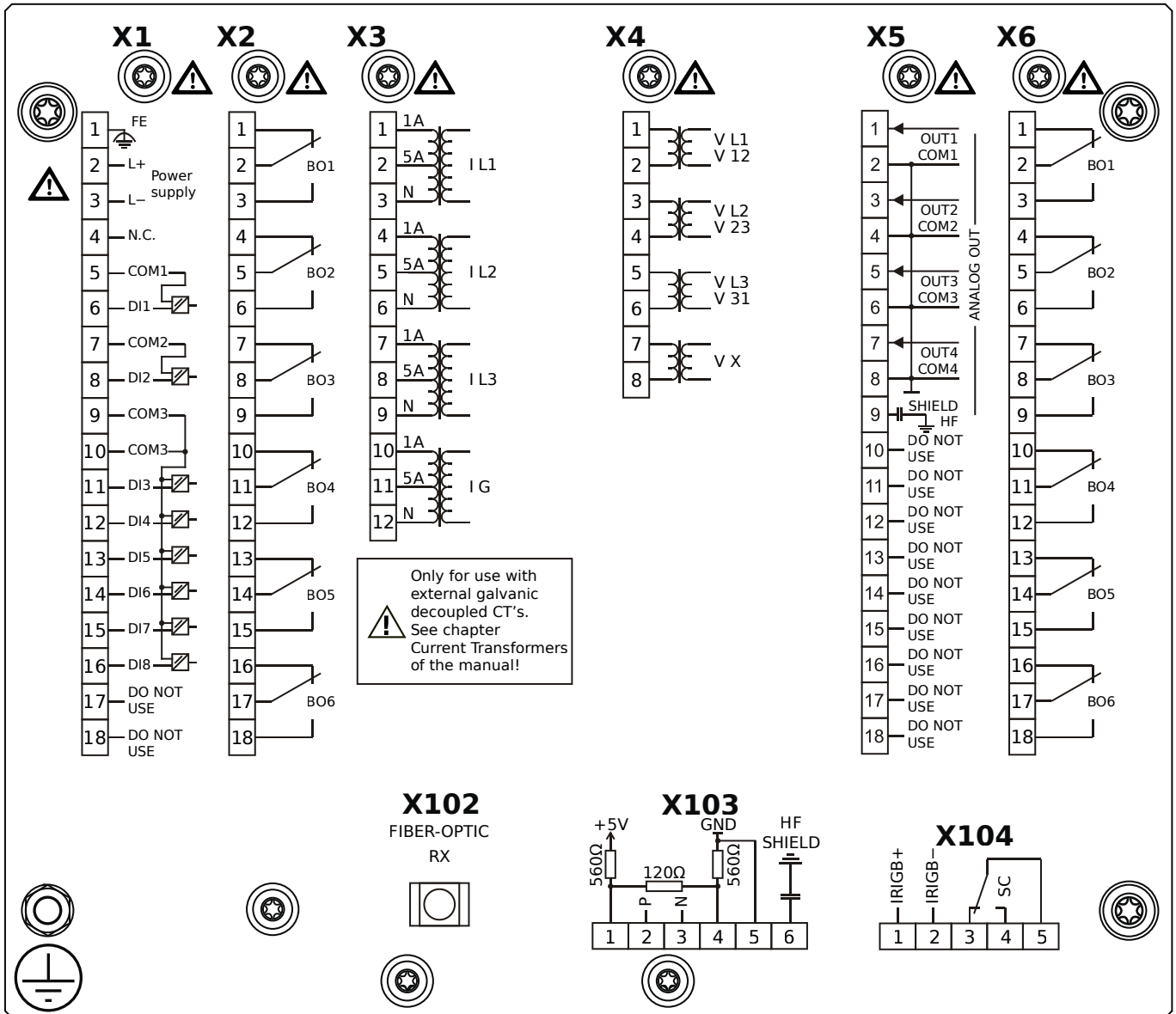

## Housing B2, small display, 19" rack mounting

- X1** – DI8-X1: Wide-range power supply unit, incl. 2 non-grouped digital inputs and 6 grouped digital inputs
- X2** – OR6: Assembly Group with 6 Output Relays (Changeover / Form C)
- X3** – TI: Standard current measuring card
- X4** – TU: Card with 4 voltage transformer measuring inputs (0 ... 800 VAC, under UL: 0 ... 600 VAC)
- X5** – AnO4: Analog Outputs
- X6** – OR6: Assembly Group with 6 Output Relays (Changeover / Form C)
- X102** – Universal Resistance-Temperature Detector (URTD) input, Fiber optics interface, Versatile Link
- X103** – Modbus RTU / IEC 60870-5-103 / DNP3.0 RTU, RS485, Terminals
- X104** – IRIG-B00X, incl. System Contact (Supervision Contact)

# MRMV4-2C0BBB

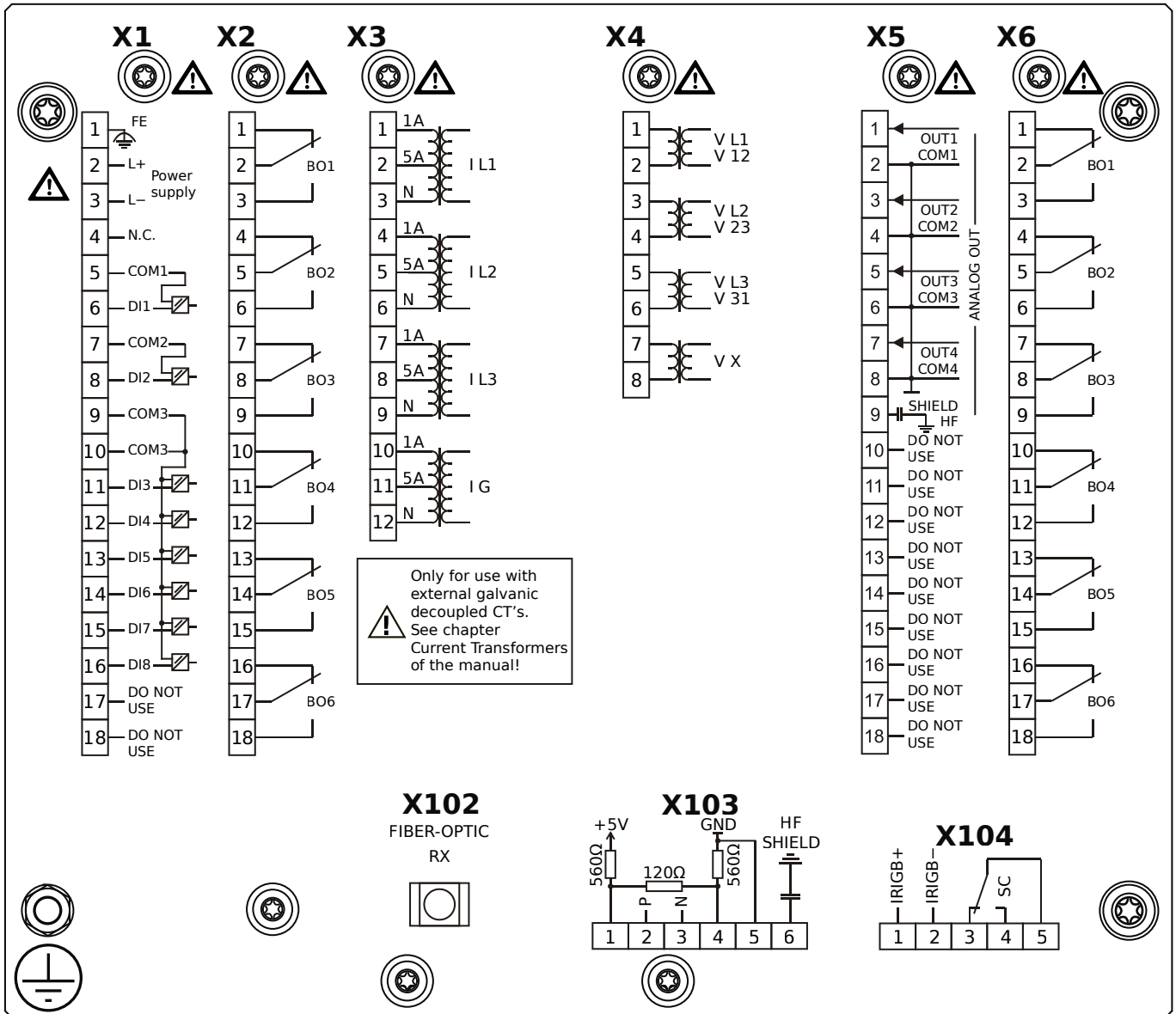

## Housing B2, small display, 19" rack mounting

+ Conformal Coating (for installations in harsh environment)

- X1** – DI8-X1: Wide-range power supply unit, incl. 2 non-grouped digital inputs and 6 grouped digital inputs
- X2** – OR6: Assembly Group with 6 Output Relays (Changeover / Form C)
- X3** – TI: Standard current measuring card
- X4** – TU: Card with 4 voltage transformer measuring inputs (0 ... 800 VAC, under UL: 0 ... 600 VAC)
- X5** – AnO4: Analog Outputs
- X6** – OR6: Assembly Group with 6 Output Relays (Changeover / Form C)
- X102** – Universal Resistance-Temperature Detector (URTD) input, Fiber optics interface, Versatile Link
- X103** – Modbus RTU / IEC 60870-5-103 / DNP3.0 RTU, RS485, Terminals
- X104** – IRIG-B00X, incl. System Contact (Supervision Contact)

# MRMV4-2C0BCA

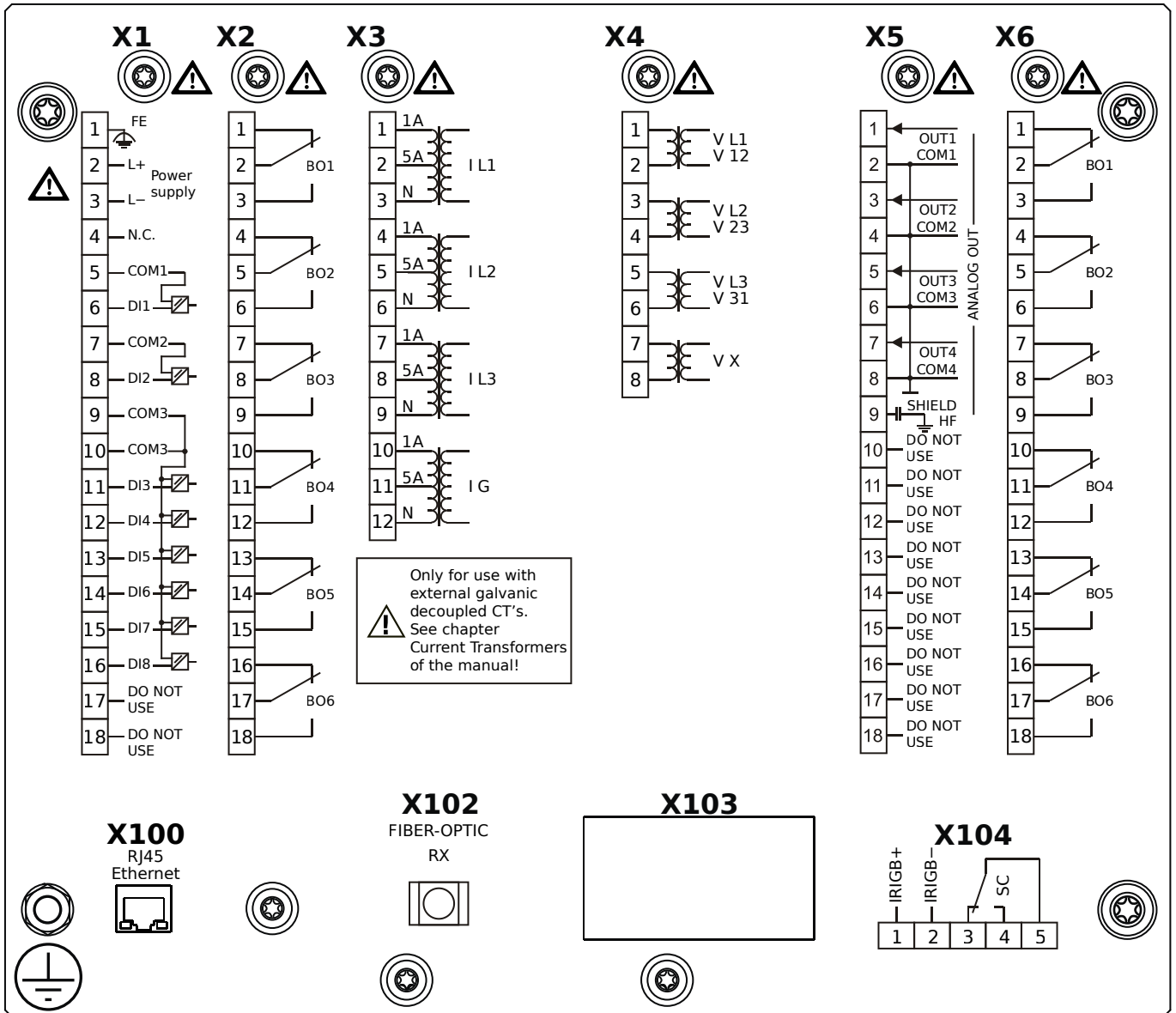

## Housing B2, small display, 19" rack mounting

- X1** – DI8-X1: Wide-range power supply unit, incl. 2 non-grouped digital inputs and 6 grouped digital inputs
- X2** – OR6: Assembly Group with 6 Output Relays (Changeover / Form C)
- X3** – TI: Standard current measuring card
- X4** – TU: Card with 4 voltage transformer measuring inputs (0 ... 800 VAC, under UL: 0 ... 600 VAC)
- X5** – AnO4: Analog Outputs
- X6** – OR6: Assembly Group with 6 Output Relays (Changeover / Form C)
- X100** – Modbus TCP / IEC 60870-5-104 / DNP3.0 TCP/UDP, Ethernet interface, 100 Mbit/s, RJ45 (BASE100-FX)
- X102** – Universal Resistance-Temperature Detector (URTD) input, Fiber optics interface, Versatile Link
- X104** – IRIG-B00X, incl. System Contact (Supervision Contact)

# MRMV4-2C0BCB

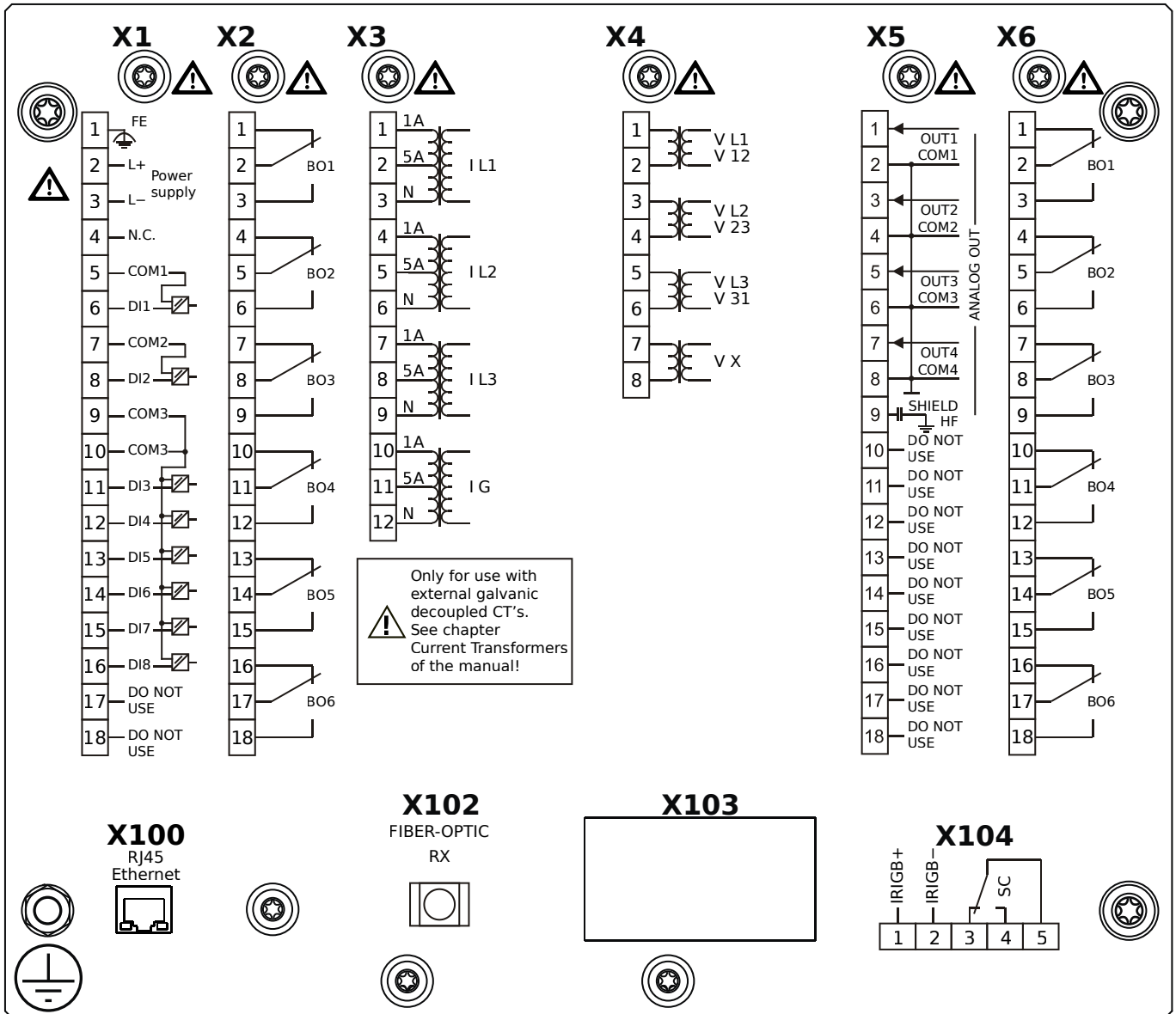

## Housing B2, small display, 19" rack mounting

+ Conformal Coating (for installations in harsh environment)

- X1** – DI8-X1: Wide-range power supply unit, incl. 2 non-grouped digital inputs and 6 grouped digital inputs
- X2** – OR6: Assembly Group with 6 Output Relays (Changeover / Form C)
- X3** – TI: Standard current measuring card
- X4** – TU: Card with 4 voltage transformer measuring inputs (0 ... 800 VAC, under UL: 0 ... 600 VAC)
- X5** – AnO4: Analog Outputs
- X6** – OR6: Assembly Group with 6 Output Relays (Changeover / Form C)
- X100** – Modbus TCP / IEC 60870-5-104 / DNP3.0 TCP/UDP, Ethernet interface, 100 Mbit/s, RJ45 (BASE100-FX)
- X102** – Universal Resistance-Temperature Detector (URTD) input, Fiber optics interface, Versatile Link
- X104** – IRIG-B00X, incl. System Contact (Supervision Contact)

# MRMV4-2C0BDA

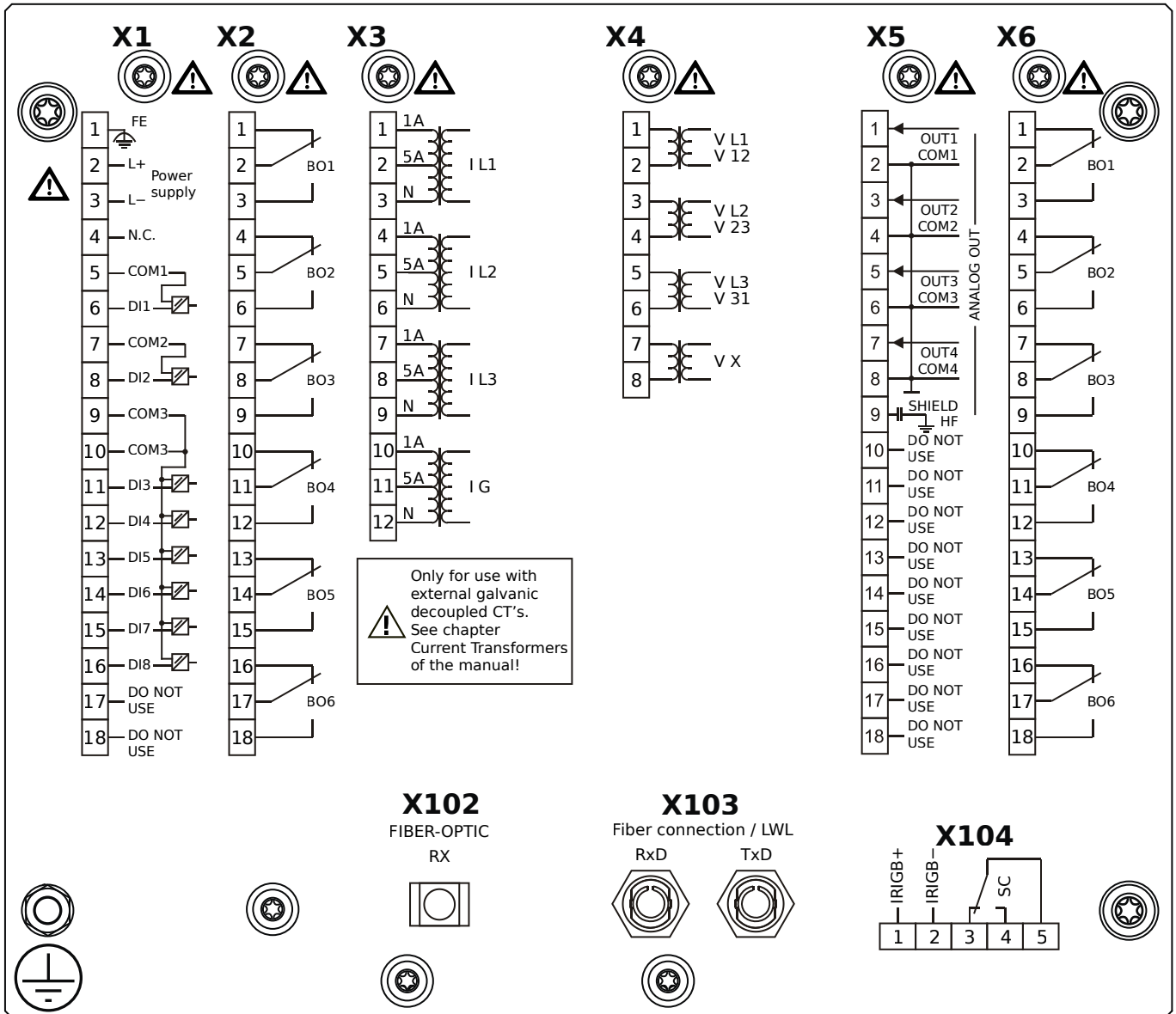

## Housing B2, small display, 19" rack mounting

- X1** – DI8-X1: Wide-range power supply unit, incl. 2 non-grouped digital inputs and 6 grouped digital inputs
- X2** – OR6: Assembly Group with 6 Output Relays (Changeover / Form C)
- X3** – TI: Standard current measuring card
- X4** – TU: Card with 4 voltage transformer measuring inputs (0 ... 800 VAC, under UL: 0 ... 600 VAC)
- X5** – AnO4: Analog Outputs
- X6** – OR6: Assembly Group with 6 Output Relays (Changeover / Form C)
- X102** – Universal Resistance-Temperature Detector (URTD) input, Fiber optics interface, Versatile Link
- X103** – Profibus-DP, Fiber optics interface, ST Connector
- X104** – IRIG-B00X, incl. System Contact (Supervision Contact)



# MRMV4-2C0BDB

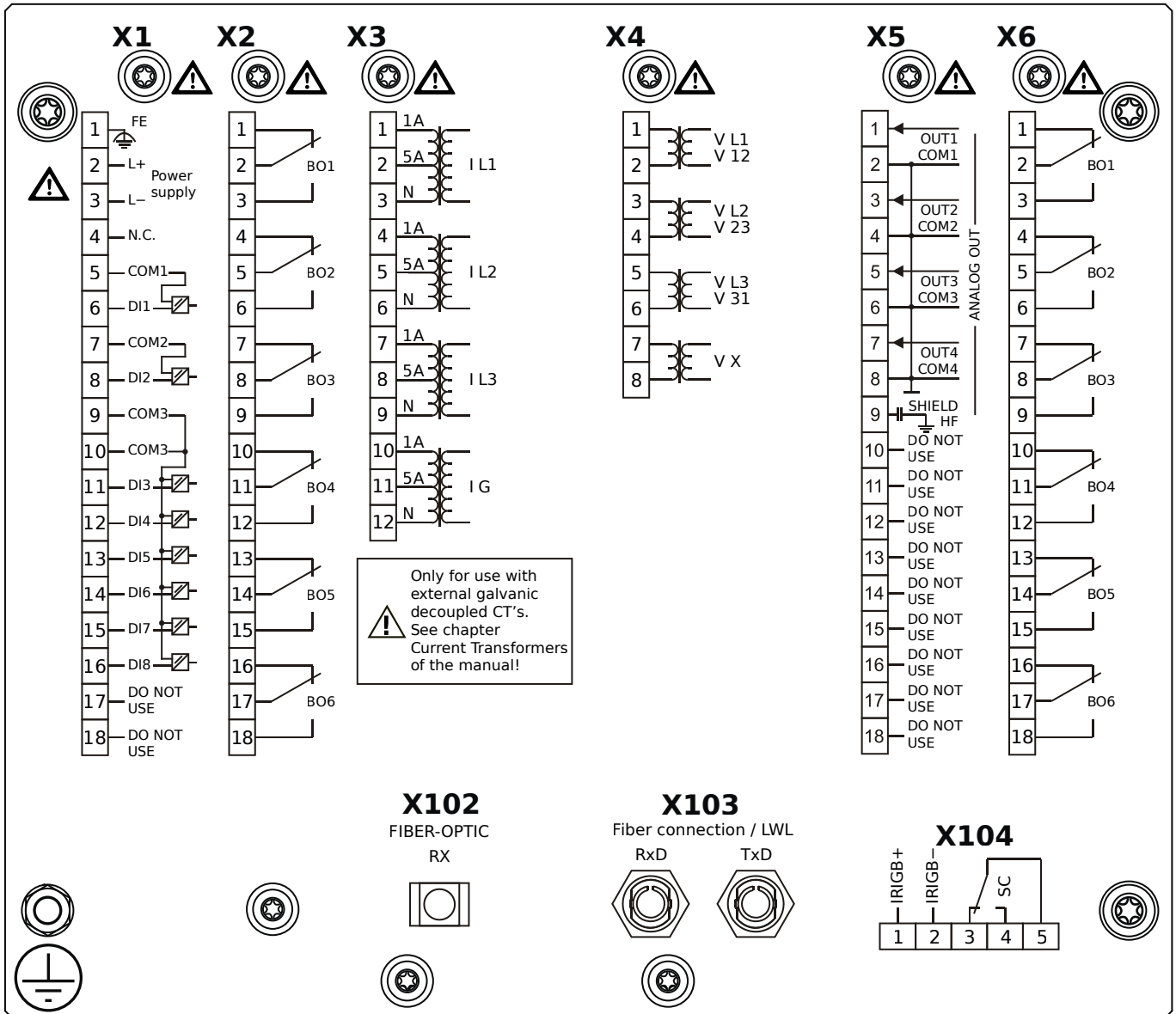

## Housing B2, small display, 19" rack mounting

+ Conformal Coating (for installations in harsh environment)

- X1** – DI8-X1: Wide-range power supply unit, incl. 2 non-grouped digital inputs and 6 grouped digital inputs
- X2** – OR6: Assembly Group with 6 Output Relays (Changeover / Form C)
- X3** – TI: Standard current measuring card
- X4** – TU: Card with 4 voltage transformer measuring inputs (0 ... 800 VAC, under UL: 0 ... 600 VAC)
- X5** – AnO4: Analog Outputs
- X6** – OR6: Assembly Group with 6 Output Relays (Changeover / Form C)
- X102** – Universal Resistance-Temperature Detector (URTD) input, Fiber optics interface, Versatile Link
- X103** – Profibus-DP, Fiber optics interface, ST Connector
- X104** – IRIG-B00X, incl. System Contact (Supervision Contact)

# MRMV4-2C0BEA

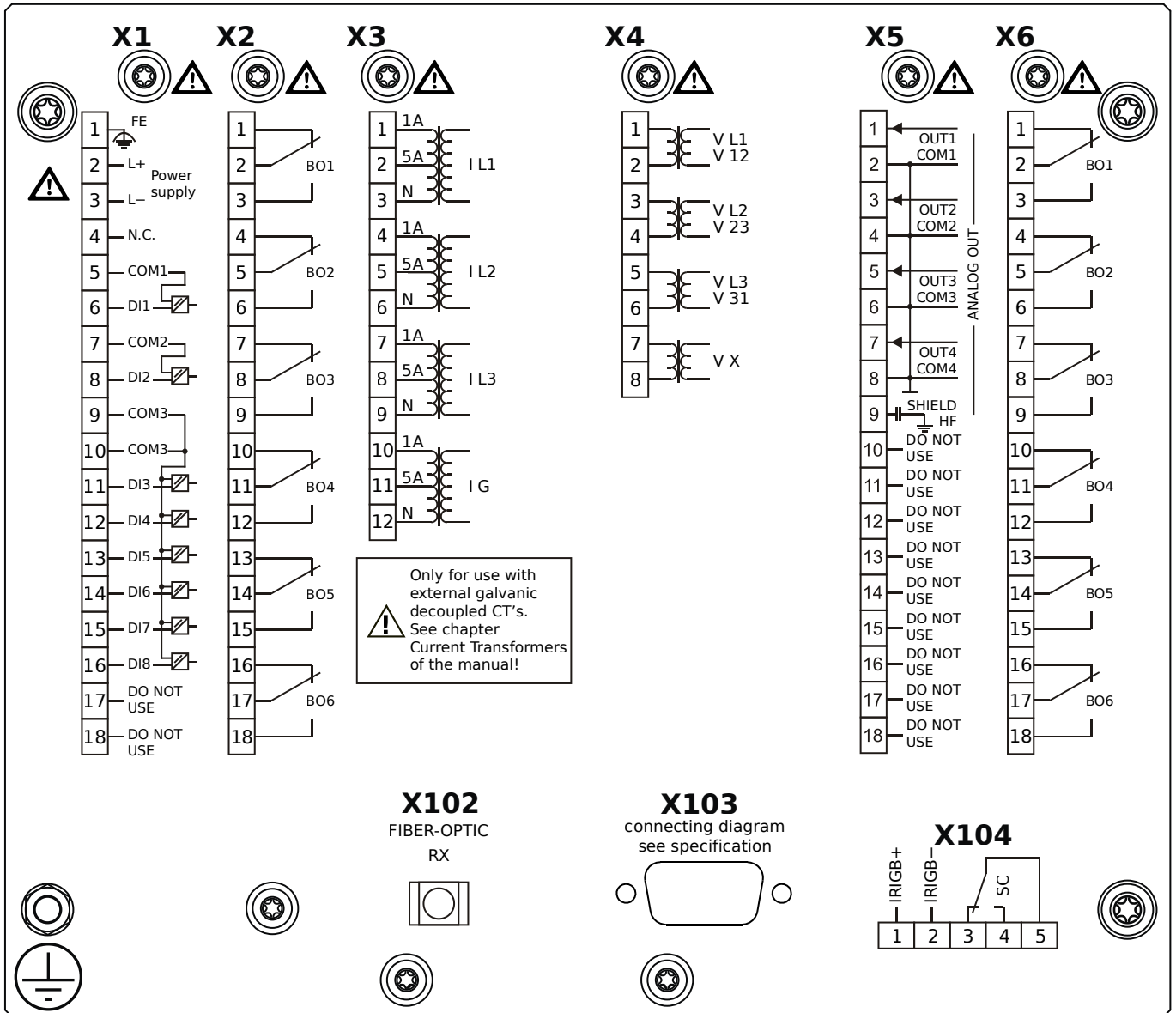

## Housing B2, small display, 19" rack mounting

- X1** – DI8-X1: Wide-range power supply unit, incl. 2 non-grouped digital inputs and 6 grouped digital inputs
- X2** – OR6: Assembly Group with 6 Output Relays (Changeover / Form C)
- X3** – TI: Standard current measuring card
- X4** – TU: Card with 4 voltage transformer measuring inputs (0 ... 800 VAC, under UL: 0 ... 600 VAC)
- X5** – AnO4: Analog Outputs
- X6** – OR6: Assembly Group with 6 Output Relays (Changeover / Form C)
- X102** – Universal Resistance-Temperature Detector (URTD) input, Fiber optics interface, Versatile Link
- X103** – Profibus-DP, RS485, D-SUB
- X104** – IRIG-B00X, incl. System Contact (Supervision Contact)

# MRMV4-2C0BEB

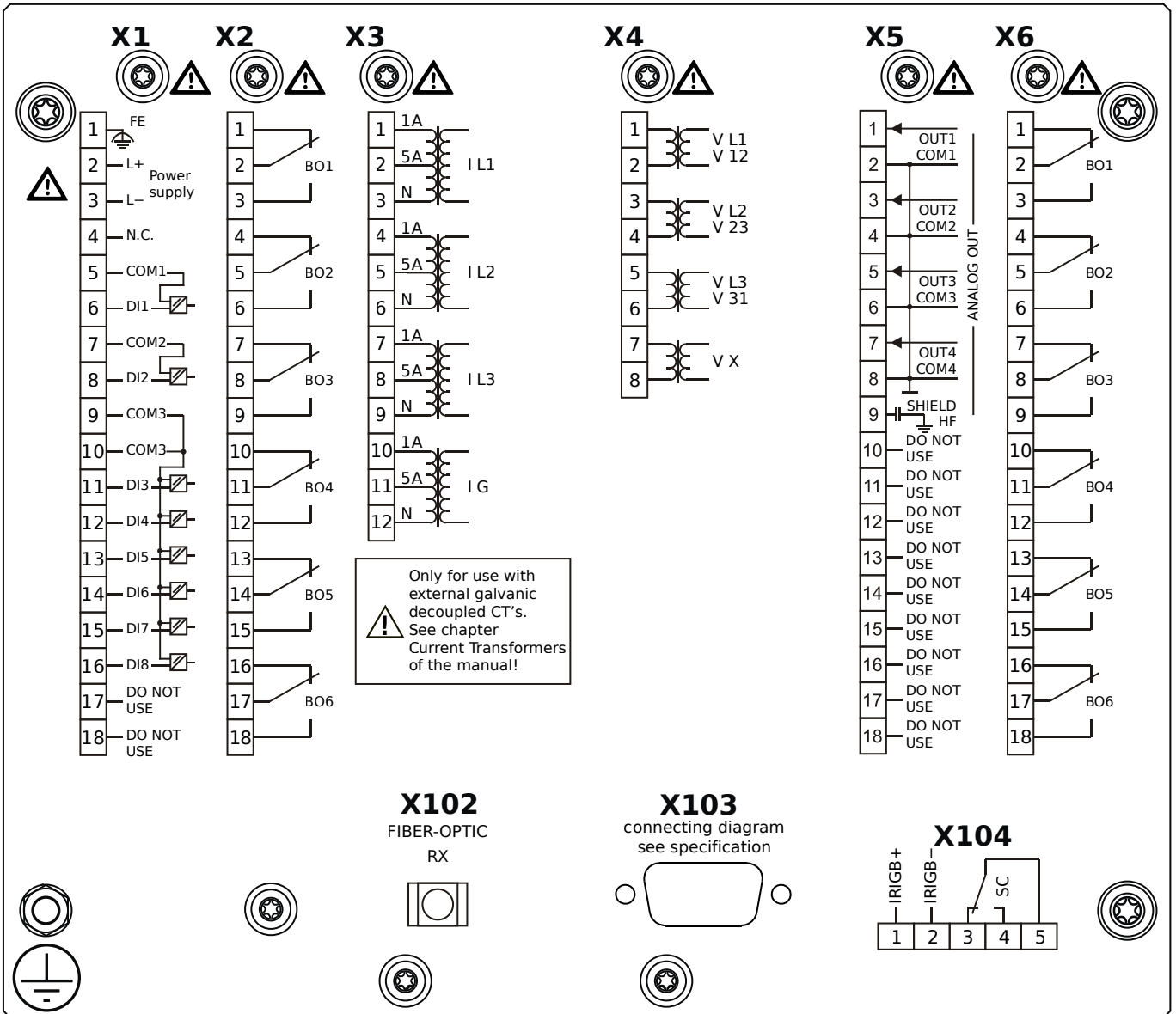

## Housing B2, small display, 19" rack mounting

+ Conformal Coating (for installations in harsh environment)

- X1** – DI8-X1: Wide-range power supply unit, incl. 2 non-grouped digital inputs and 6 grouped digital inputs
- X2** – OR6: Assembly Group with 6 Output Relays (Changeover / Form C)
- X3** – TI: Standard current measuring card
- X4** – TU: Card with 4 voltage transformer measuring inputs (0 ... 800 VAC, under UL: 0 ... 600 VAC)
- X5** – AnO4: Analog Outputs
- X6** – OR6: Assembly Group with 6 Output Relays (Changeover / Form C)
- X102** – Universal Resistance-Temperature Detector (URTD) input, Fiber optics interface, Versatile Link
- X103** – Profibus-DP, RS485, D-SUB
- X104** – IRIG-B00X, incl. System Contact (Supervision Contact)

# MRMV4-2C0BFA

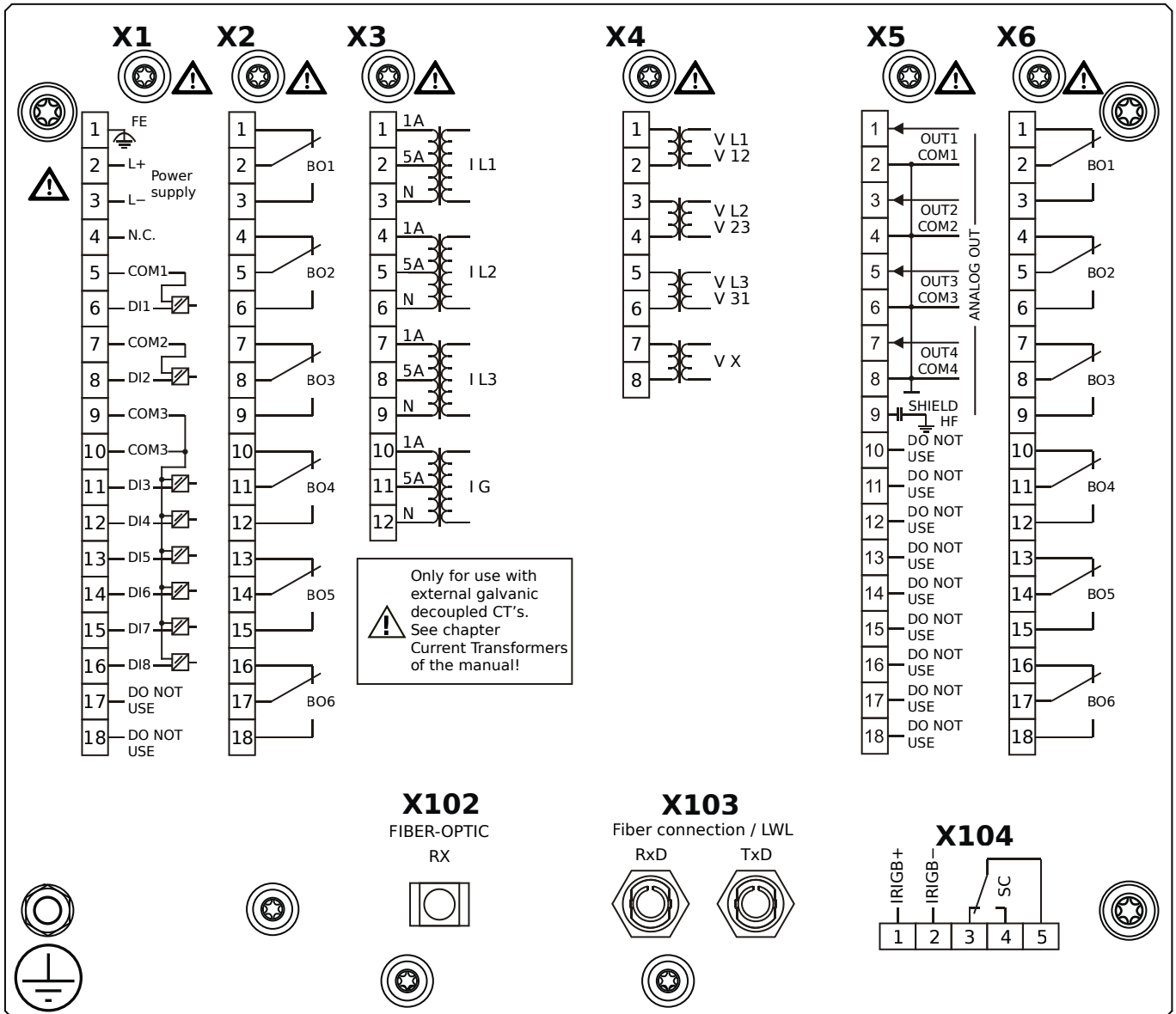

## Housing B2, small display, 19" rack mounting

- X1** – DI8-X1: Wide-range power supply unit, incl. 2 non-grouped digital inputs and 6 grouped digital inputs
- X2** – OR6: Assembly Group with 6 Output Relays (Changeover / Form C)
- X3** – TI: Standard current measuring card
- X4** – TU: Card with 4 voltage transformer measuring inputs (0 ... 800 VAC, under UL: 0 ... 600 VAC)
- X5** – AnO4: Analog Outputs
- X6** – OR6: Assembly Group with 6 Output Relays (Changeover / Form C)
- X102** – Universal Resistance-Temperature Detector (URTD) input, Fiber optics interface, Versatile Link
- X103** – Modbus RTU / IEC 60870-5-103 / DNP3.0 RTU, Fiber optics interface, ST Connector
- X104** – IRIG-B00X, incl. System Contact (Supervision Contact)

# MRMV4-2C0BFB

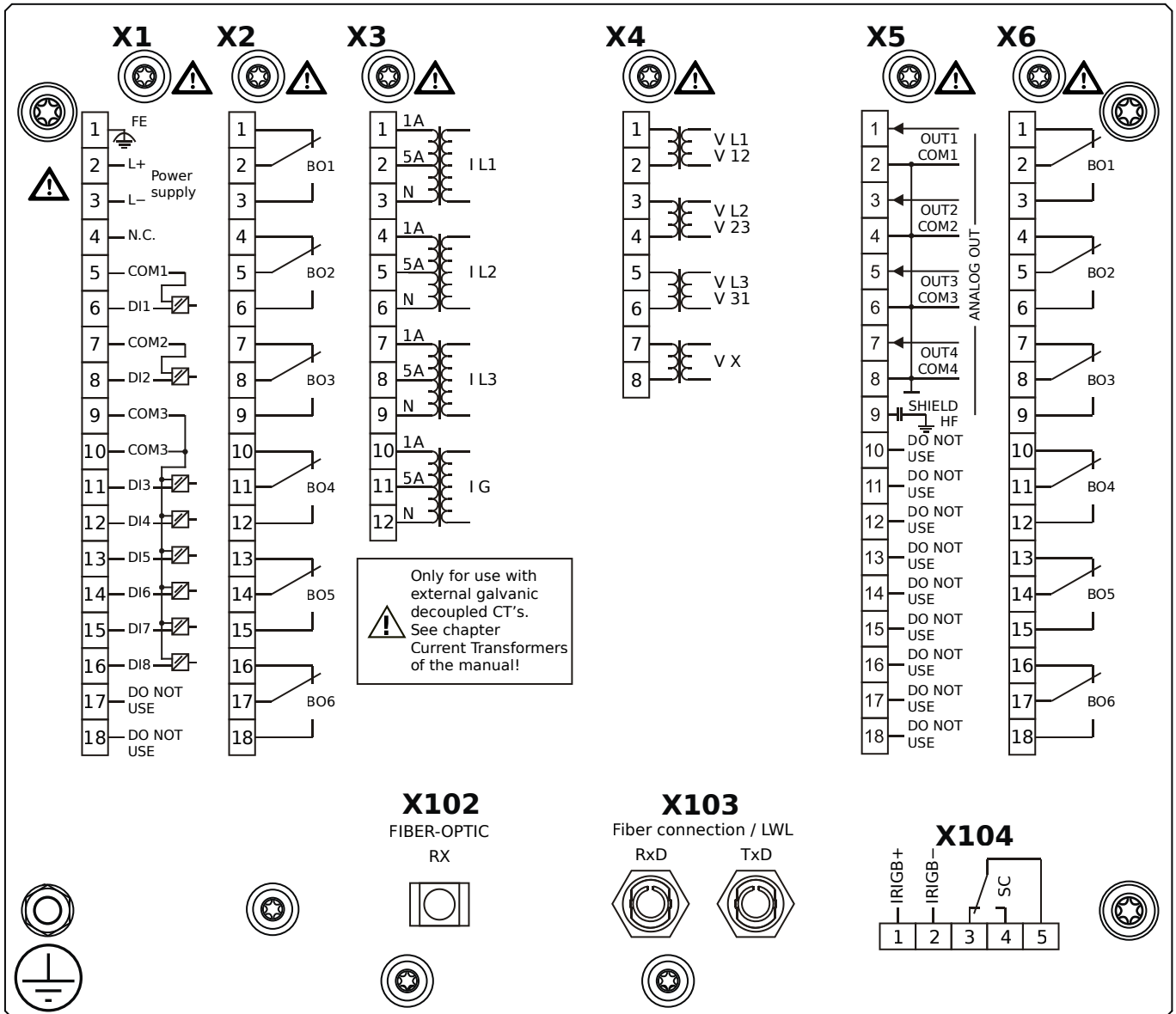

## Housing B2, small display, 19" rack mounting

- + Conformal Coating (for installations in harsh environment)

- X1** – DI8-X1: Wide-range power supply unit, incl. 2 non-grouped digital inputs and 6 grouped digital inputs
- X2** – OR6: Assembly Group with 6 Output Relays (Changeover / Form C)
- X3** – TI: Standard current measuring card
- X4** – TU: Card with 4 voltage transformer measuring inputs (0 ... 800 VAC, under UL: 0 ... 600 VAC)
- X5** – AnO4: Analog Outputs
- X6** – OR6: Assembly Group with 6 Output Relays (Changeover / Form C)
- X102** – Universal Resistance-Temperature Detector (URTD) input, Fiber optics interface, Versatile Link
- X103** – Modbus RTU / IEC 60870-5-103 / DNP3.0 RTU, Fiber optics interface, ST Connector
- X104** – IRIG-B00X, incl. System Contact (Supervision Contact)

# MRMV4-2C0BGA

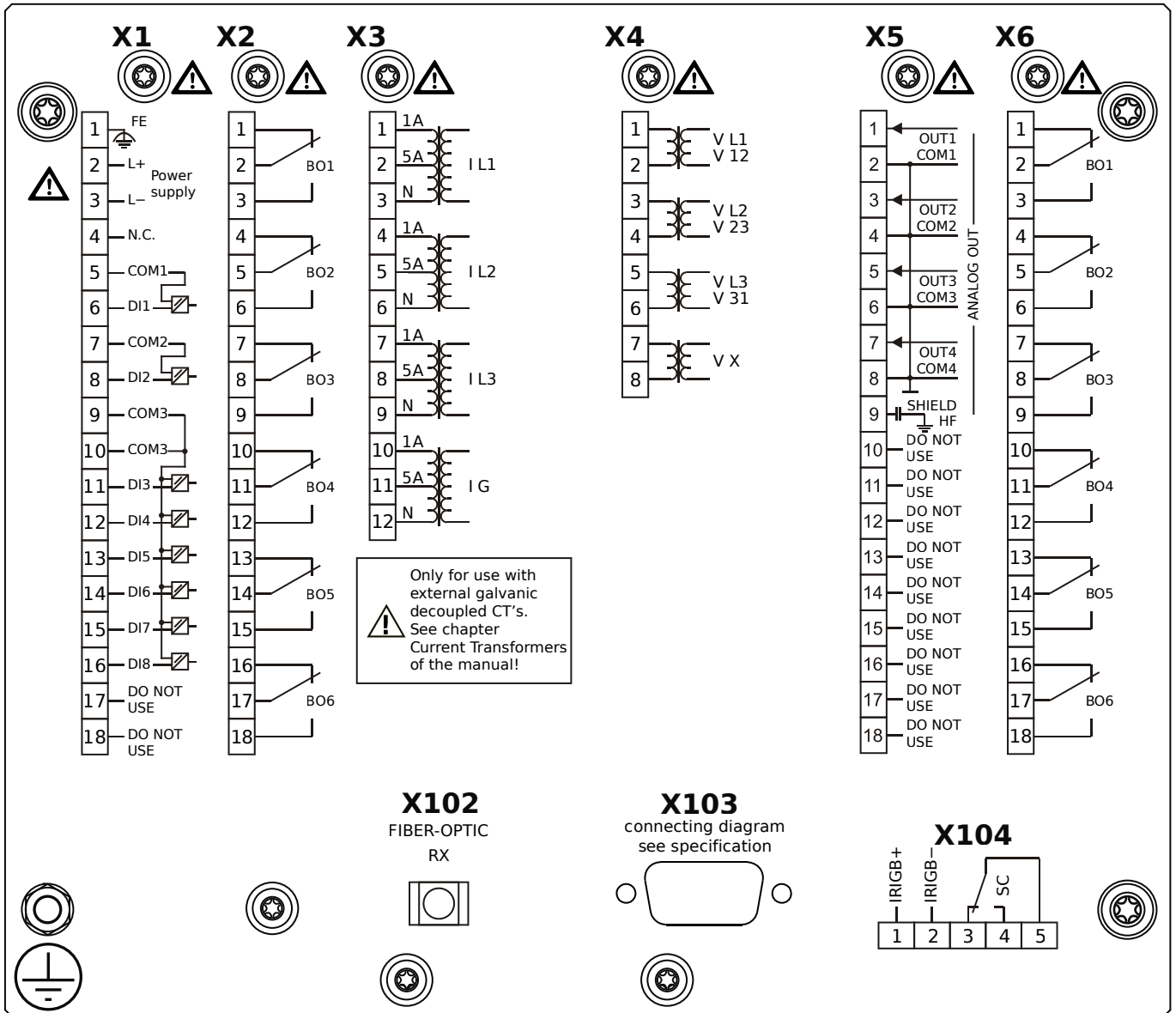

## Housing B2, small display, 19" rack mounting

- X1** – DI8-X1: Wide-range power supply unit, incl. 2 non-grouped digital inputs and 6 grouped digital inputs
- X2** – OR6: Assembly Group with 6 Output Relays (Changeover / Form C)
- X3** – TI: Standard current measuring card
- X4** – TU: Card with 4 voltage transformer measuring inputs (0 ... 800 VAC, under UL: 0 ... 600 VAC)
- X5** – AnO4: Analog Outputs
- X6** – OR6: Assembly Group with 6 Output Relays (Changeover / Form C)
- X102** – Universal Resistance-Temperature Detector (URTD) input, Fiber optics interface, Versatile Link
- X103** – Modbus RTU / IEC 60870-5-103 / DNP3.0 RTU, RS485, D-SUB
- X104** – IRIG-B00X, incl. System Contact (Supervision Contact)

# MRMV4-2C0BGB

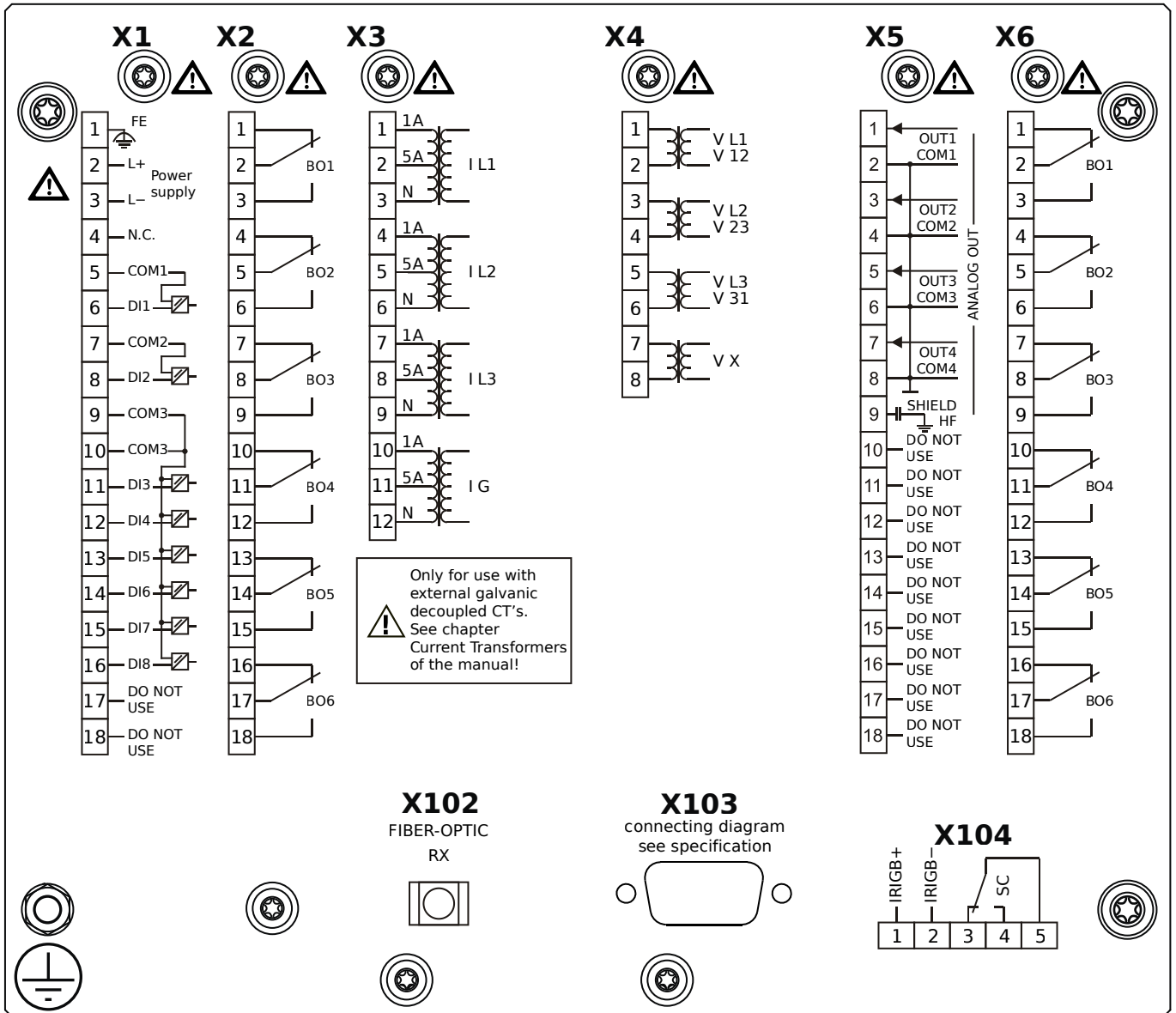

## Housing B2, small display, 19" rack mounting

+ Conformal Coating (for installations in harsh environment)

- X1** – DI8-X1: Wide-range power supply unit, incl. 2 non-grouped digital inputs and 6 grouped digital inputs
- X2** – OR6: Assembly Group with 6 Output Relays (Changeover / Form C)
- X3** – TI: Standard current measuring card
- X4** – TU: Card with 4 voltage transformer measuring inputs (0 ... 800 VAC, under UL: 0 ... 600 VAC)
- X5** – AnO4: Analog Outputs
- X6** – OR6: Assembly Group with 6 Output Relays (Changeover / Form C)
- X102** – Universal Resistance-Temperature Detector (URTD) input, Fiber optics interface, Versatile Link
- X103** – Modbus RTU / IEC 60870-5-103 / DNP3.0 RTU, RS485, D-SUB
- X104** – IRIG-B00X, incl. System Contact (Supervision Contact)

# MRMV4-2C0BHA

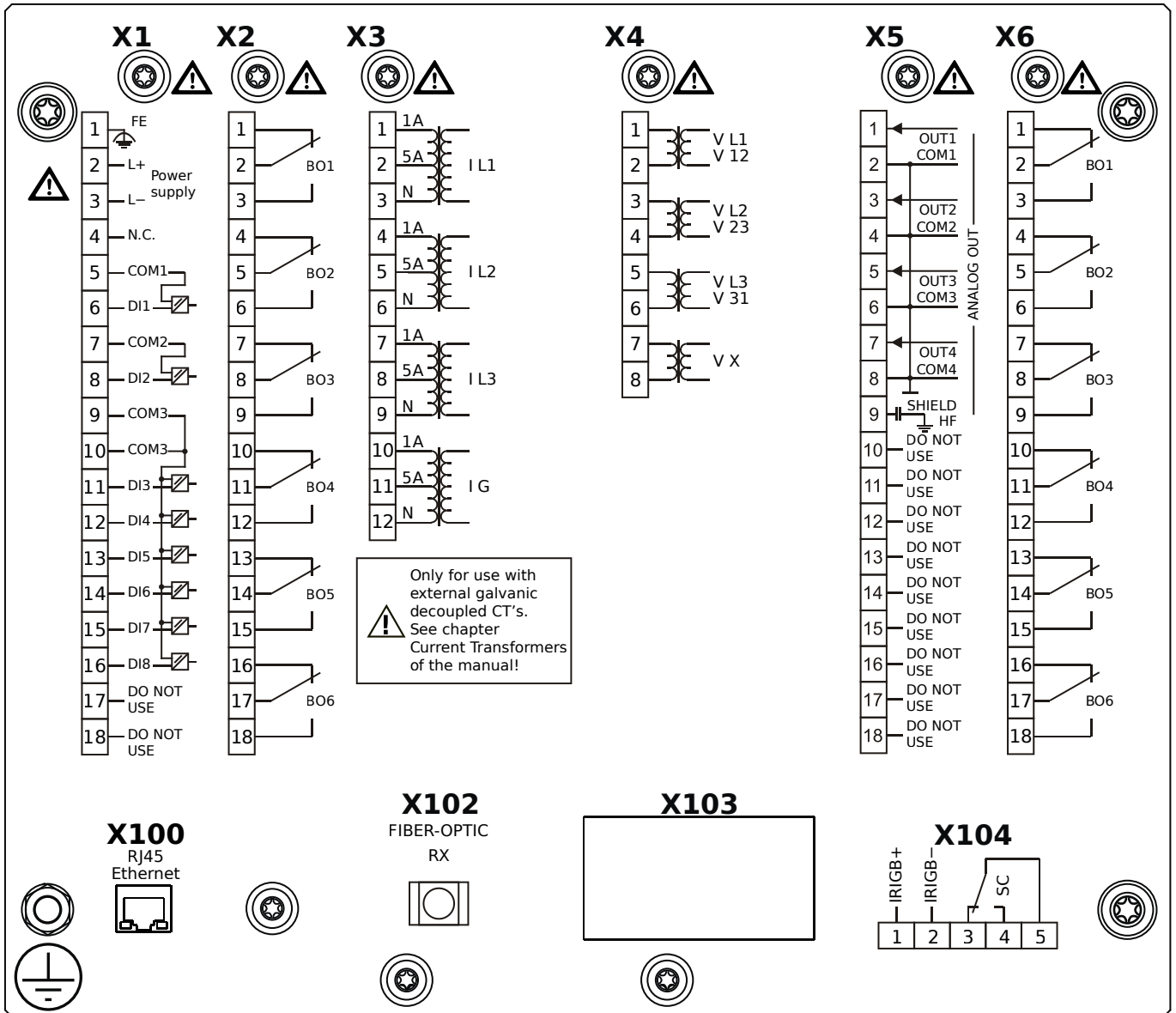

## Housing B2, small display, 19" rack mounting

- X1** – DI8-X1: Wide-range power supply unit, incl. 2 non-grouped digital inputs and 6 grouped digital inputs
- X2** – OR6: Assembly Group with 6 Output Relays (Changeover / Form C)
- X3** – TI: Standard current measuring card
- X4** – TU: Card with 4 voltage transformer measuring inputs (0 ... 800 VAC, under UL: 0 ... 600 VAC)
- X5** – AnO4: Analog Outputs
- X6** – OR6: Assembly Group with 6 Output Relays (Changeover / Form C)
- X100** – IEC 61850 / Modbus TCP / IEC 60870-5-104 / DNP3.0 TCP/UDP, Ethernet interface, 100 Mbit/s, RJ45 (BASE100-FX)
- X102** – Universal Resistance-Temperature Detector (URTD) input, Fiber optics interface, Versatile Link
- X104** – IRIG-B00X, incl. System Contact (Supervision Contact)



# MRMV4-2C0BHB

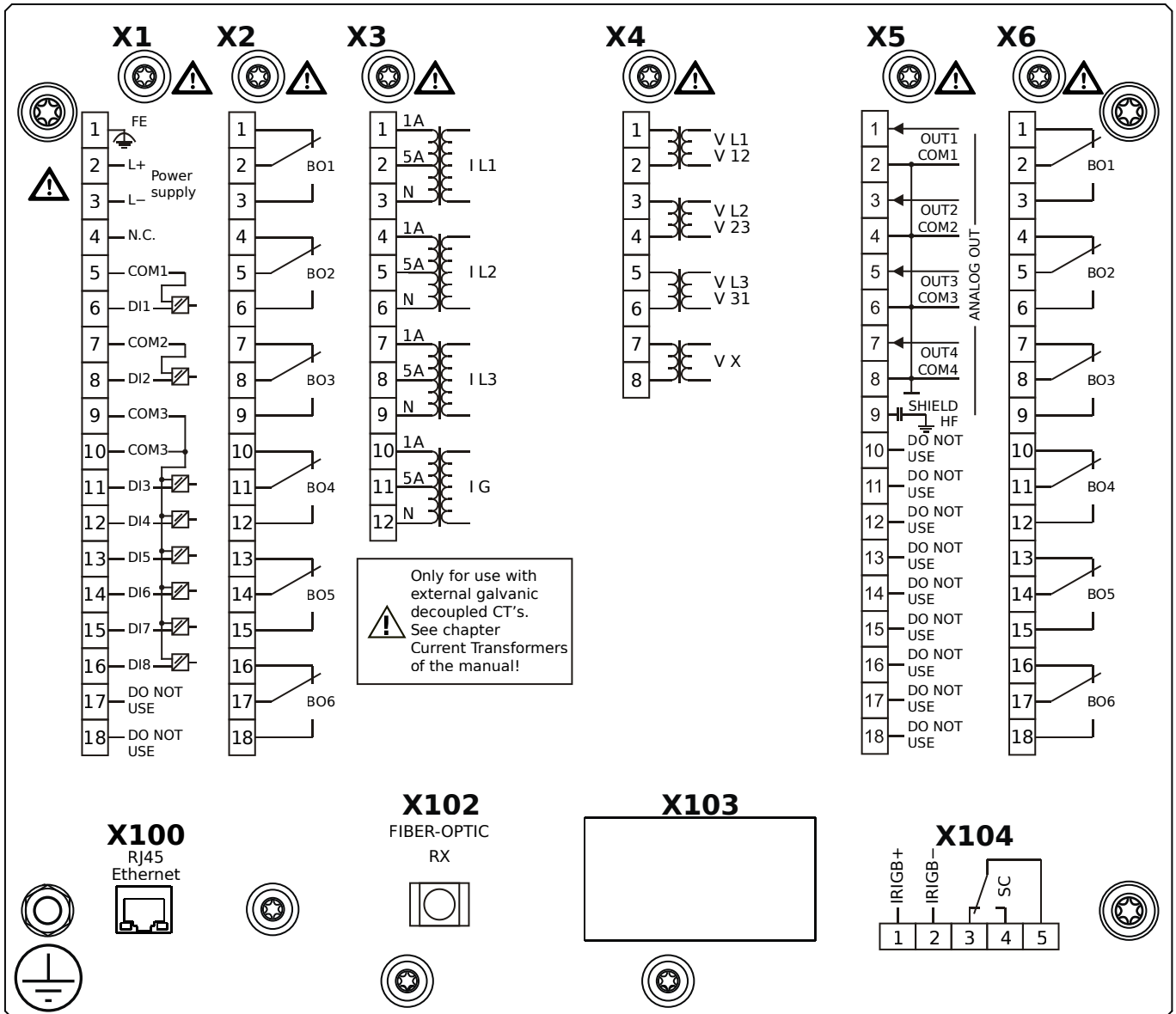

## Housing B2, small display, 19" rack mounting

+ Conformal Coating (for installations in harsh environment)

**X1** – DI8-X1: Wide-range power supply unit, incl. 2 non-grouped digital inputs and 6 grouped digital inputs

**X2** – OR6: Assembly Group with 6 Output Relays (Changeover / Form C)

**X3** – TI: Standard current measuring card

**X4** – TU: Card with 4 voltage transformer measuring inputs (0 ... 800 VAC, under UL: 0 ... 600 VAC)

**X5** – AnO4: Analog Outputs

**X6** – OR6: Assembly Group with 6 Output Relays (Changeover / Form C)

**X100** – IEC 61850 / Modbus TCP / IEC 60870-5-104 / DNP3.0 TCP/UDP, Ethernet interface, 100 Mbit/s, RJ45 (BASE100-

FX)

**X102** – Universal Resistance-Temperature Detector (URTD) input, Fiber optics interface, Versatile Link

**X104** – IRIG-B00X, incl. System Contact (Supervision Contact)

# MRMV4-2C0BIA

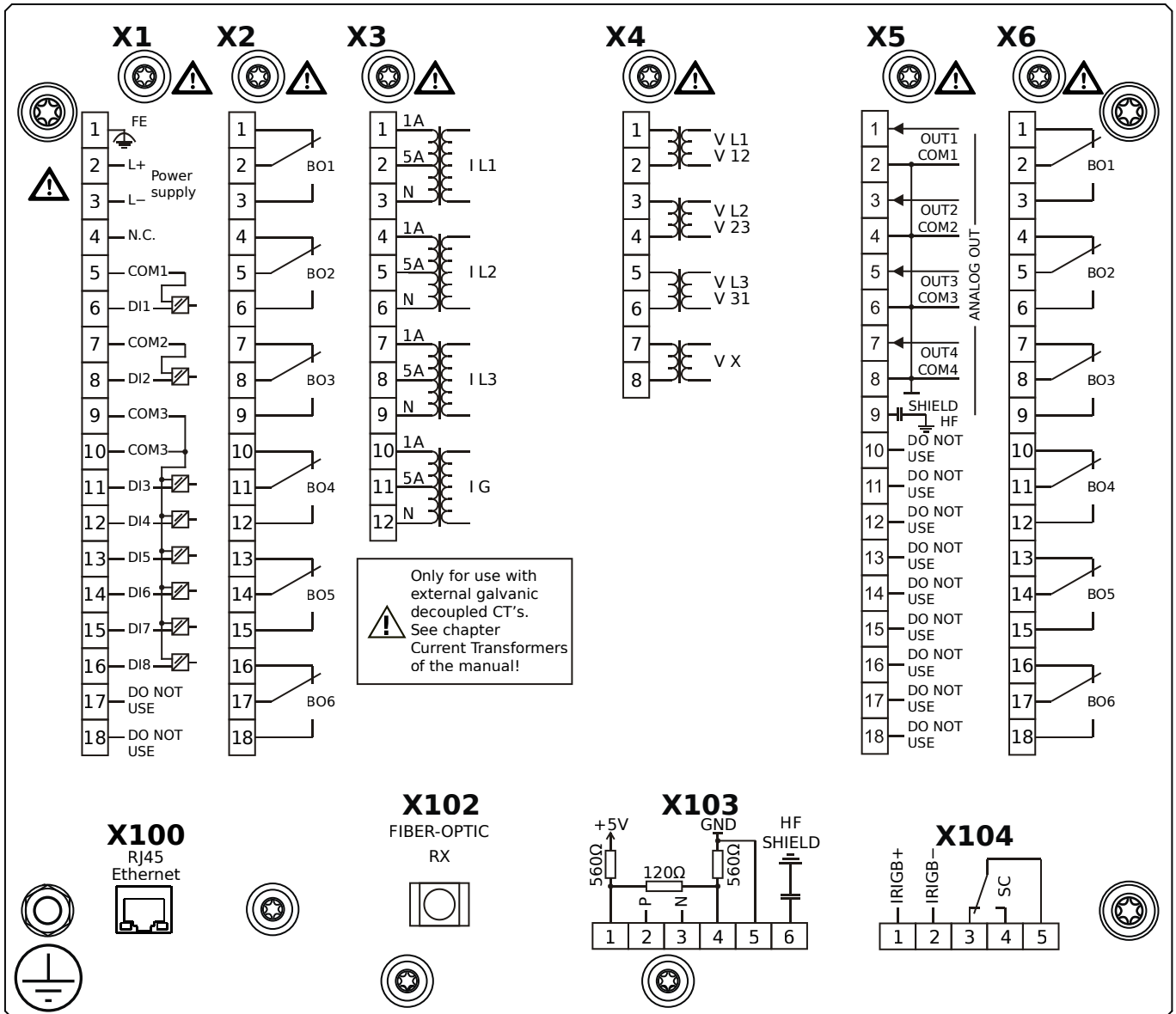

## Housing B2, small display, 19" rack mounting

- X1** – DI8-X1: Wide-range power supply unit, incl. 2 non-grouped digital inputs and 6 grouped digital inputs
- X2** – OR6: Assembly Group with 6 Output Relays (Changeover / Form C)
- X3** – TI: Standard current measuring card
- X4** – TU: Card with 4 voltage transformer measuring inputs (0 ... 800 VAC, under UL: 0 ... 600 VAC)
- X5** – AnO4: Analog Outputs
- X6** – OR6: Assembly Group with 6 Output Relays (Changeover / Form C)
- X100** – Modbus TCP / IEC 60870-5-104 / DNP3.0 TCP/UDP, Ethernet interface, 100 Mbit/s, RJ45 (BASE100-FX)
- X102** – Universal Resistance-Temperature Detector (URTD) input, Fiber optics interface, Versatile Link
- X103** – IEC 60870-5-103 / Modbus RTU / DNP3.0 RTU, RS485, Terminals
- X104** – IRIG-B00X, incl. System Contact (Supervision Contact)

# MRMV4-2C0BIB

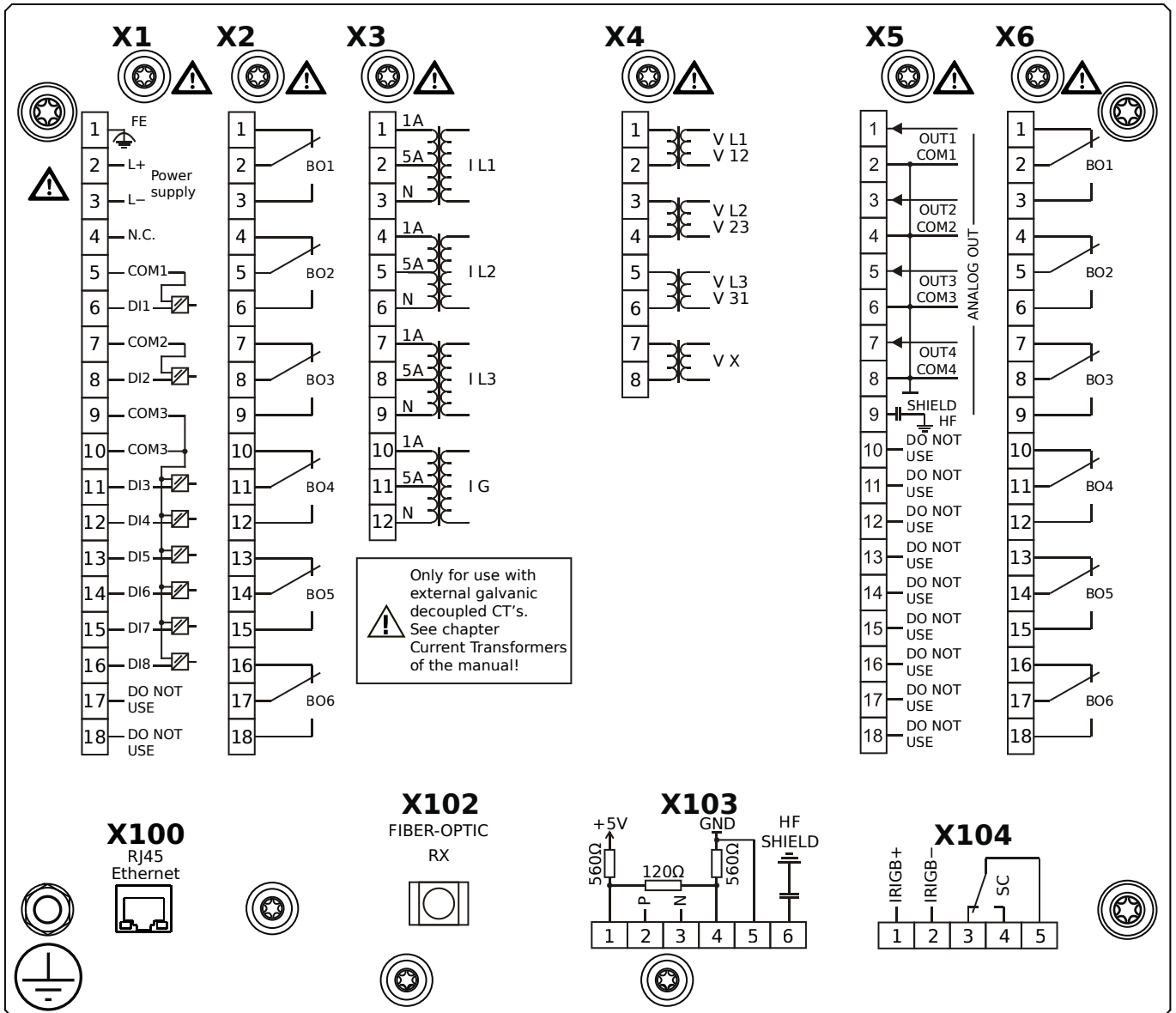

## Housing B2, small display, 19" rack mounting

+ Conformal Coating (for installations in harsh environment)

- X1** – DI8-X1: Wide-range power supply unit, incl. 2 non-grouped digital inputs and 6 grouped digital inputs
- X2** – OR6: Assembly Group with 6 Output Relays (Changeover / Form C)
- X3** – TI: Standard current measuring card
- X4** – TU: Card with 4 voltage transformer measuring inputs (0 ... 800 VAC, under UL: 0 ... 600 VAC)
- X5** – AnO4: Analog Outputs
- X6** – OR6: Assembly Group with 6 Output Relays (Changeover / Form C)
- X100** – Modbus TCP / IEC 60870-5-104 / DNP3.0 TCP/UDP, Ethernet interface, 100 Mbit/s, RJ45 (BASE100-FX)
- X102** – Universal Resistance-Temperature Detector (URTD) input, Fiber optics interface, Versatile Link
- X103** – IEC 60870-5-103 / Modbus RTU / DNP3.0 RTU, RS485, Terminals
- X104** – IRIG-B00X, incl. System Contact (Supervision Contact)

# MRMV4-2C0BKA

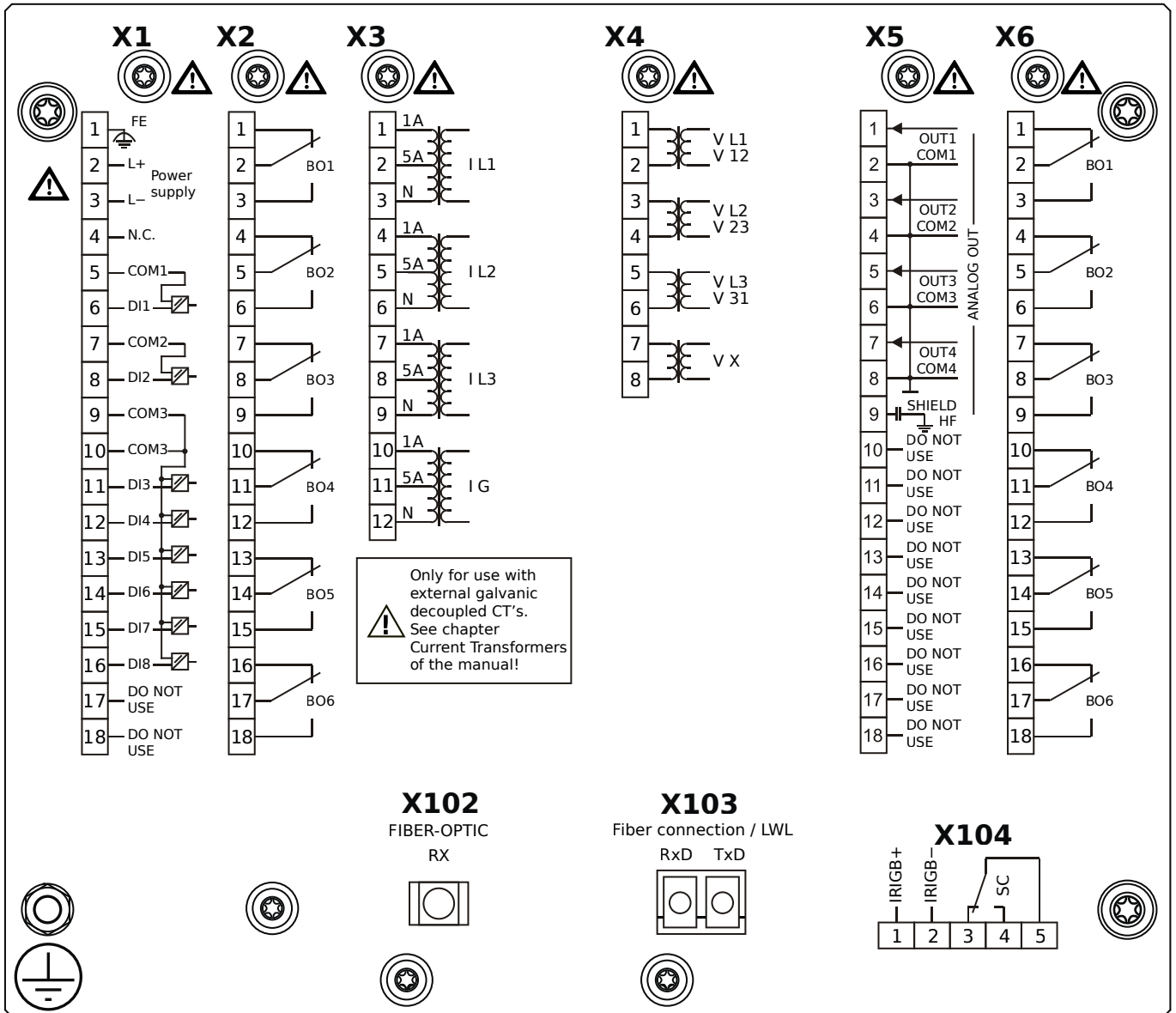

## Housing B2, small display, 19" rack mounting

- X1** – DI8-X1: Wide-range power supply unit, incl. 2 non-grouped digital inputs and 6 grouped digital inputs
- X2** – OR6: Assembly Group with 6 Output Relays (Changeover / Form C)
- X3** – TI: Standard current measuring card
- X4** – TU: Card with 4 voltage transformer measuring inputs (0 ... 800 VAC, under UL: 0 ... 600 VAC)
- X5** – AnO4: Analog Outputs
- X6** – OR6: Assembly Group with 6 Output Relays (Changeover / Form C)
- X102** – Universal Resistance-Temperature Detector (URTD) input, Fiber optics interface, Versatile Link
- X103** – IEC 61850 / Modbus TCP / IEC 60870-5-104 / DNP3.0 TCP/UDP, Fiber optics interface, LC Connector
- X104** – IRIG-B00X, incl. System Contact (Supervision Contact)

# MRMV4-2C0BKB

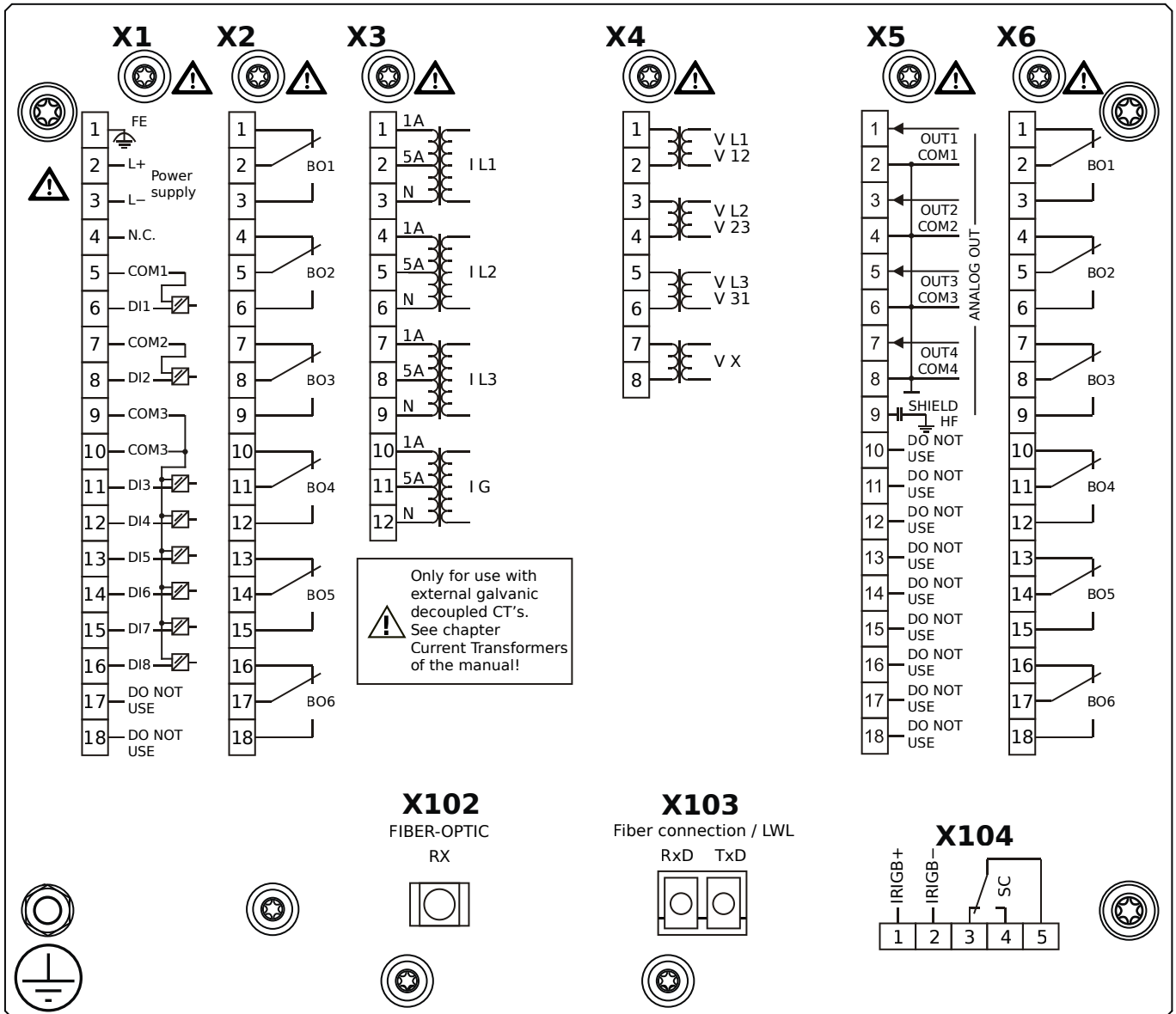

## Housing B2, small display, 19" rack mounting

- + Conformal Coating (for installations in harsh environment)

- X1** – DI8-X1: Wide-range power supply unit, incl. 2 non-grouped digital inputs and 6 grouped digital inputs
- X2** – OR6: Assembly Group with 6 Output Relays (Changeover / Form C)
- X3** – TI: Standard current measuring card
- X4** – TU: Card with 4 voltage transformer measuring inputs (0 ... 800 VAC, under UL: 0 ... 600 VAC)
- X5** – AnO4: Analog Outputs
- X6** – OR6: Assembly Group with 6 Output Relays (Changeover / Form C)
- X102** – Universal Resistance-Temperature Detector (URTD) input, Fiber optics interface, Versatile Link
- X103** – IEC 61850 / Modbus TCP / IEC 60870-5-104 / DNP3.0 TCP/UDP, Fiber optics interface, LC Connector
- X104** – IRIG-B00X, incl. System Contact (Supervision Contact)

# MRMV4-2C0BLA

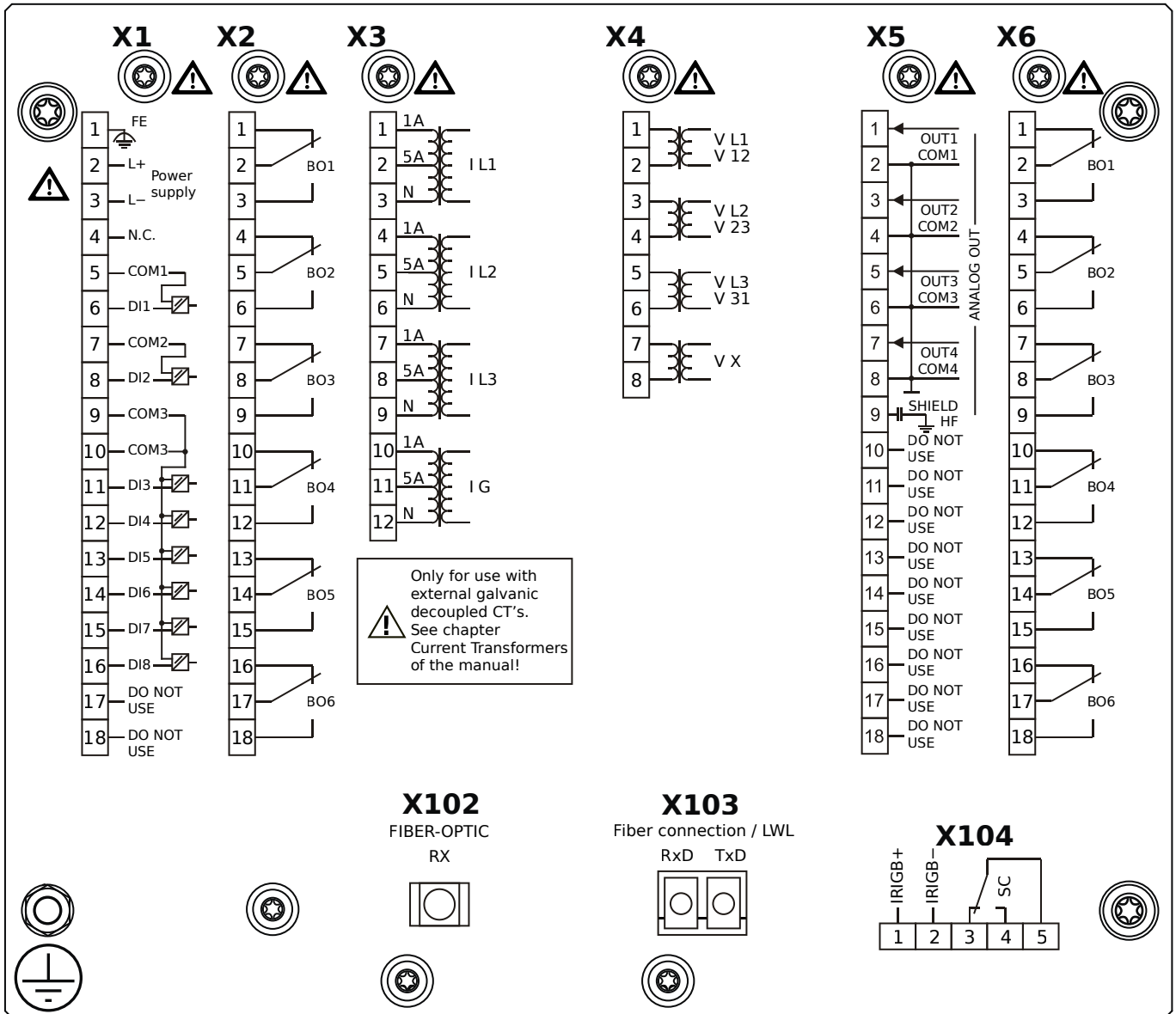

## Housing B2, small display, 19" rack mounting

- X1** – DI8-X1: Wide-range power supply unit, incl. 2 non-grouped digital inputs and 6 grouped digital inputs
- X2** – OR6: Assembly Group with 6 Output Relays (Changeover / Form C)
- X3** – TI: Standard current measuring card
- X4** – TU: Card with 4 voltage transformer measuring inputs (0 ... 800 VAC, under UL: 0 ... 600 VAC)
- X5** – AnO4: Analog Outputs
- X6** – OR6: Assembly Group with 6 Output Relays (Changeover / Form C)
- X102** – Universal Resistance-Temperature Detector (URTD) input, Fiber optics interface, Versatile Link
- X103** – Modbus TCP / IEC 60870-5-104 / DNP3.0 TCP/UDP, Fiber optics interface, LC Connector
- X104** – IRIG-B00X, incl. System Contact (Supervision Contact)

# MRMV4-2C0BLB

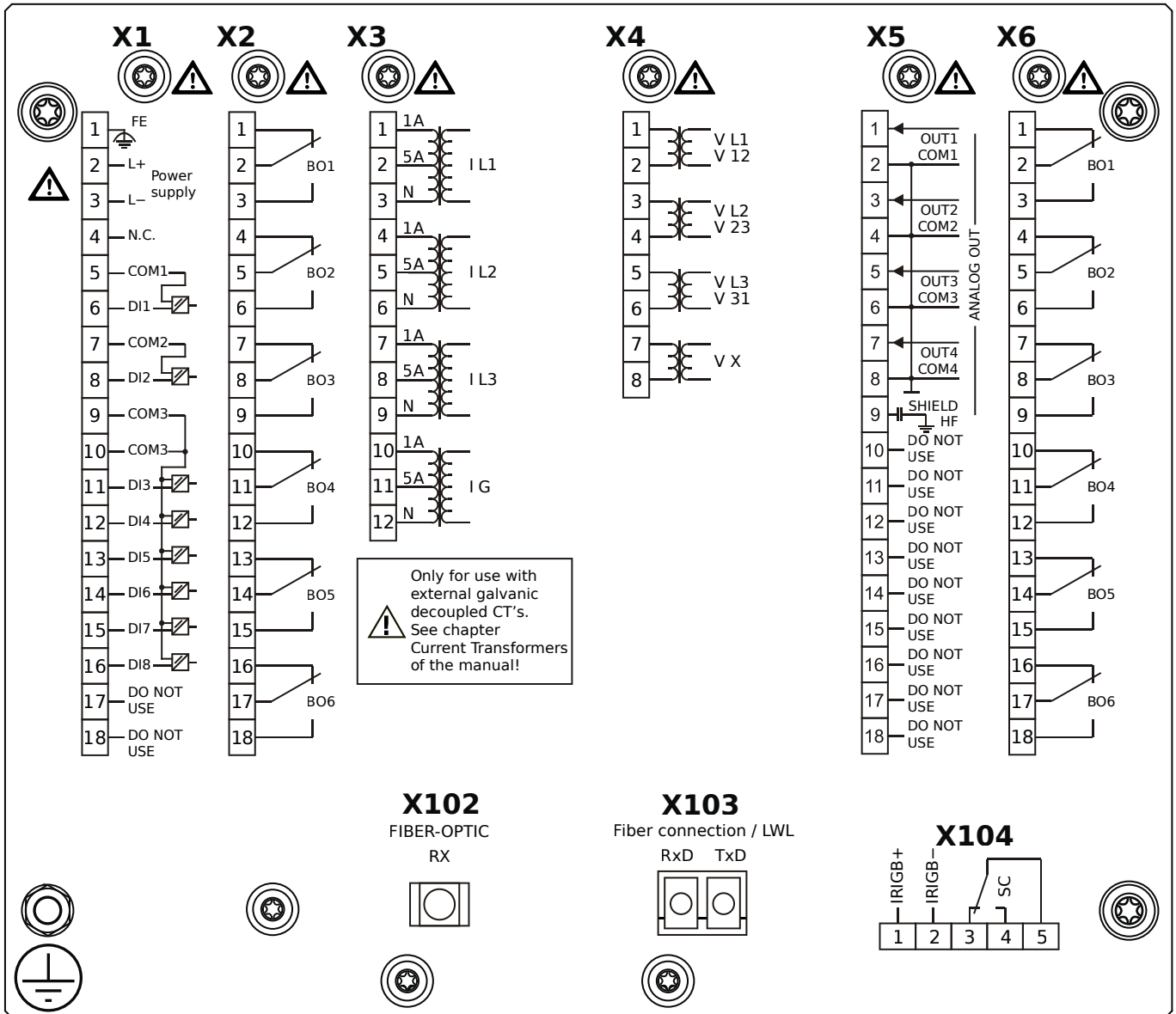

## Housing B2, small display, 19" rack mounting

+ Conformal Coating (for installations in harsh environment)

- X1** – DI8-X1: Wide-range power supply unit, incl. 2 non-grouped digital inputs and 6 grouped digital inputs
- X2** – OR6: Assembly Group with 6 Output Relays (Changeover / Form C)
- X3** – TI: Standard current measuring card
- X4** – TU: Card with 4 voltage transformer measuring inputs (0 ... 800 VAC, under UL: 0 ... 600 VAC)
- X5** – AnO4: Analog Outputs
- X6** – OR6: Assembly Group with 6 Output Relays (Changeover / Form C)
- X102** – Universal Resistance-Temperature Detector (URTD) input, Fiber optics interface, Versatile Link
- X103** – Modbus TCP / IEC 60870-5-104 / DNP3.0 TCP/UDP, Fiber optics interface, LC Connector
- X104** – IRIG-B00X, incl. System Contact (Supervision Contact)

# MRMV4-2C0BOA

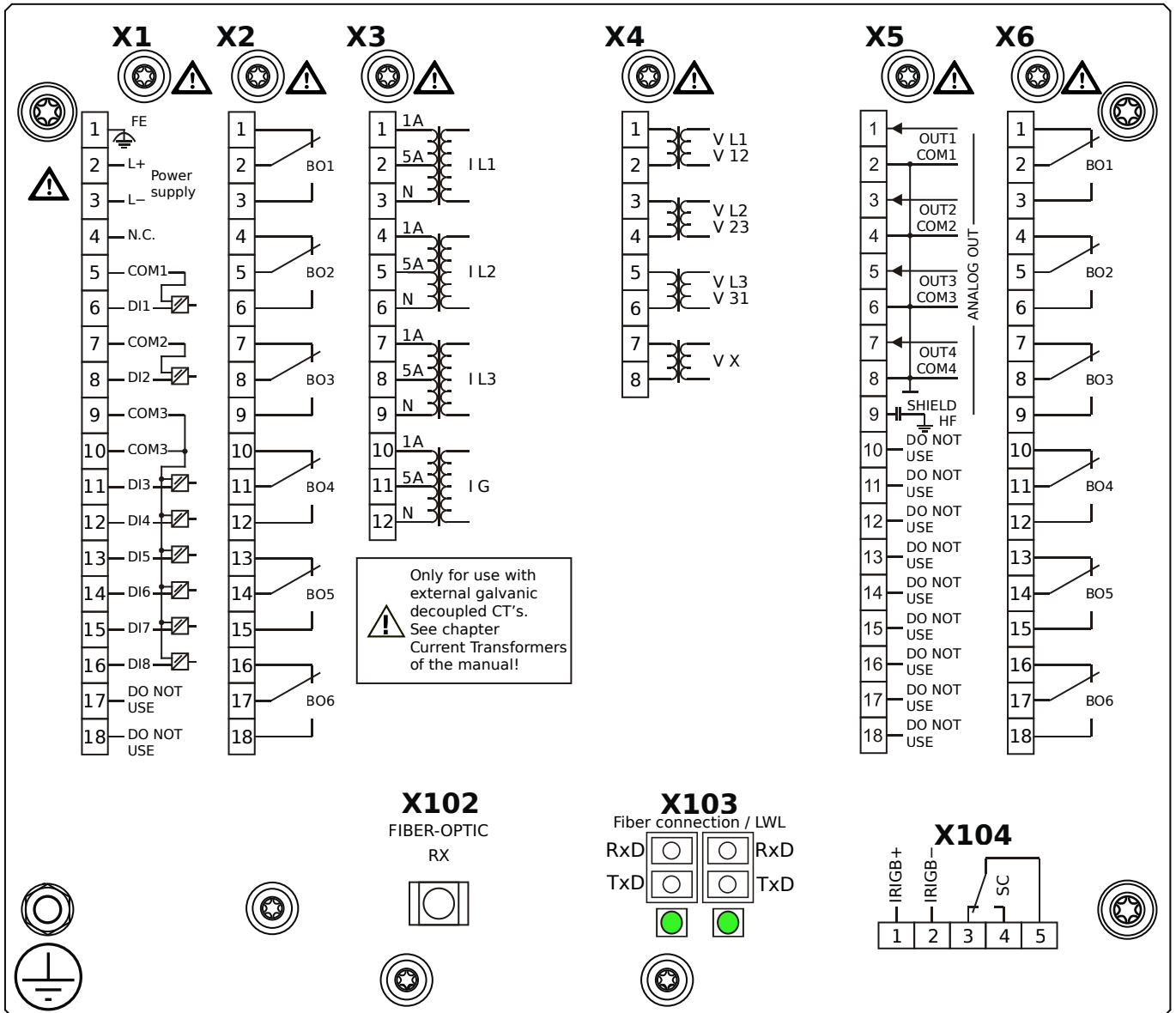

## Housing B2, small display, 19" rack mounting

- X1** – DI8-X1: Wide-range power supply unit, incl. 2 non-grouped digital inputs and 6 grouped digital inputs
- X2** – OR6: Assembly Group with 6 Output Relays (Changeover / Form C)
- X3** – TI: Standard current measuring card
- X4** – TU: Card with 4 voltage transformer measuring inputs (0 ... 800 VAC, under UL: 0 ... 600 VAC)
- X5** – AnO4: Analog Outputs
- X6** – OR6: Assembly Group with 6 Output Relays (Changeover / Form C)
- X102** – Universal Resistance-Temperature Detector (URTD) input, Fiber optics interface, Versatile Link
- X103** – Modbus TCP / IEC 60870-5-104 / DNP3.0 TCP/UDP, Redundant Fiber optics interface, LC Connector
- X104** – IRIG-B00X, incl. System Contact (Supervision Contact)



# MRMV4-2C0BOB

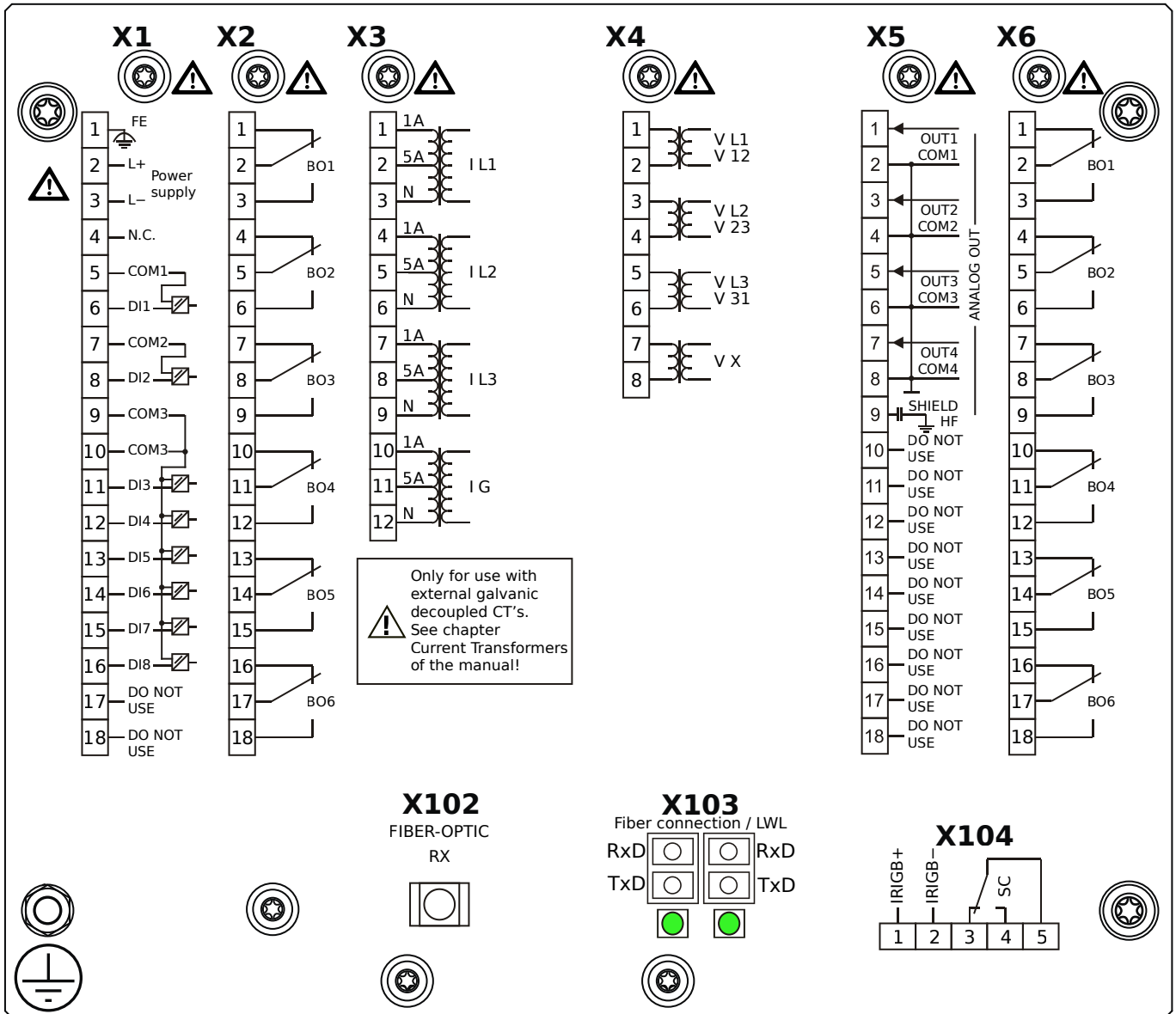

## Housing B2, small display, 19" rack mounting

+ Conformal Coating (for installations in harsh environment)

- X1** – DI8-X1: Wide-range power supply unit, incl. 2 non-grouped digital inputs and 6 grouped digital inputs
- X2** – OR6: Assembly Group with 6 Output Relays (Changeover / Form C)
- X3** – TI: Standard current measuring card
- X4** – TU: Card with 4 voltage transformer measuring inputs (0 ... 800 VAC, under UL: 0 ... 600 VAC)
- X5** – AnO4: Analog Outputs
- X6** – OR6: Assembly Group with 6 Output Relays (Changeover / Form C)
- X102** – Universal Resistance-Temperature Detector (URTD) input, Fiber optics interface, Versatile Link
- X103** – Modbus TCP / IEC 60870-5-104 / DNP3.0 TCP/UDP, Redundant Fiber optics interface, LC Connector
- X104** – IRIG-B00X, incl. System Contact (Supervision Contact)

# MRMV4-2C0BPA

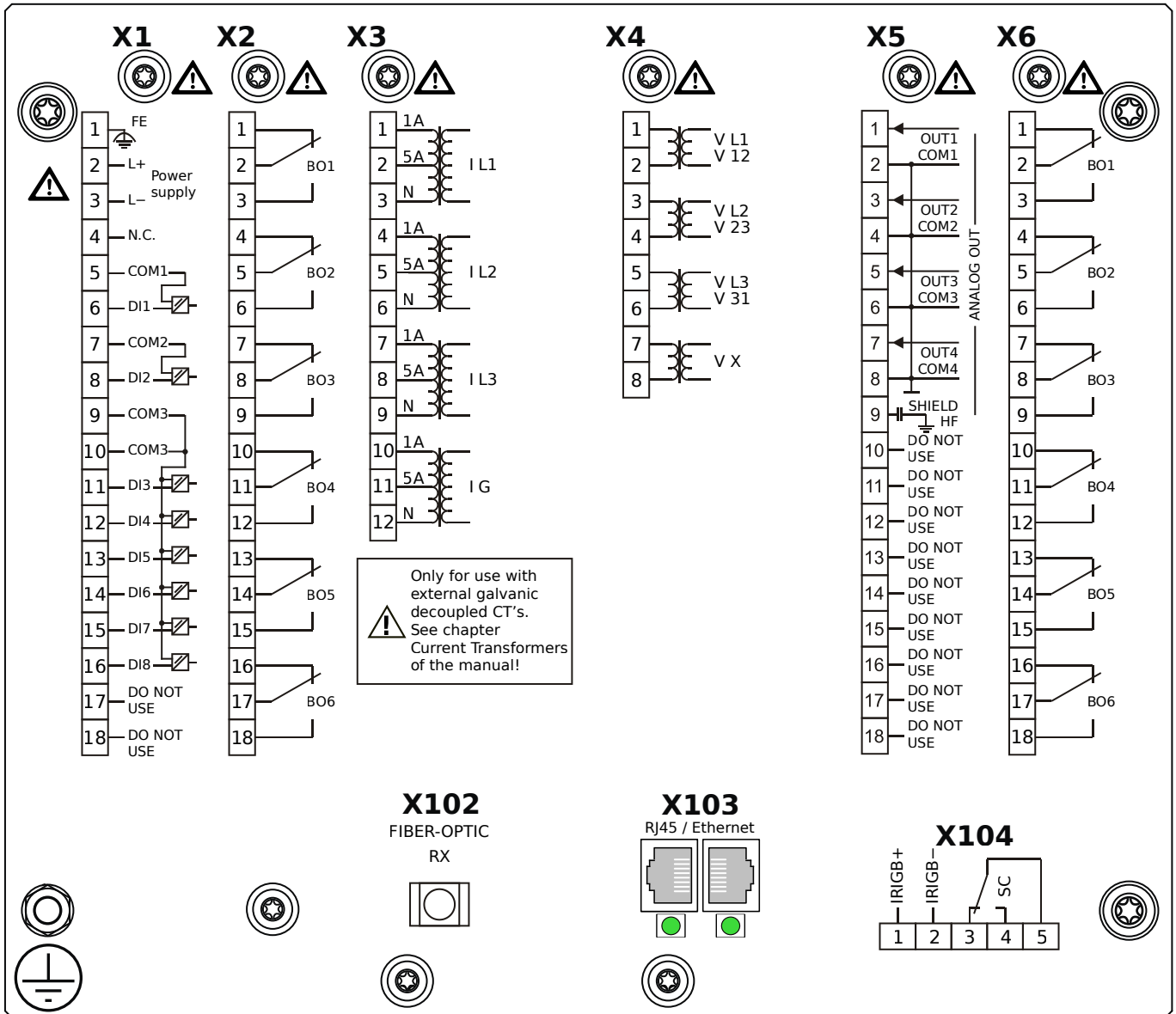

## Housing B2, small display, 19" rack mounting

- X1** – DI8-X1: Wide-range power supply unit, incl. 2 non-grouped digital inputs and 6 grouped digital inputs
- X2** – OR6: Assembly Group with 6 Output Relays (Changeover / Form C)
- X3** – TI: Standard current measuring card
- X4** – TU: Card with 4 voltage transformer measuring inputs (0 ... 800 VAC, under UL: 0 ... 600 VAC)
- X5** – AnO4: Analog Outputs
- X6** – OR6: Assembly Group with 6 Output Relays (Changeover / Form C)
- X102** – Universal Resistance-Temperature Detector (URTD) input, Fiber optics interface, Versatile Link
- X103** – Modbus TCP / IEC 60870-5-104 / DNP3.0 TCP/UDP, Redundant Ethernet interface, 100 Mbit/s, RJ45 (BASE100-FX)
- X104** – IRIG-B00X, incl. System Contact (Supervision Contact)

# MRMV4-2C0BPB

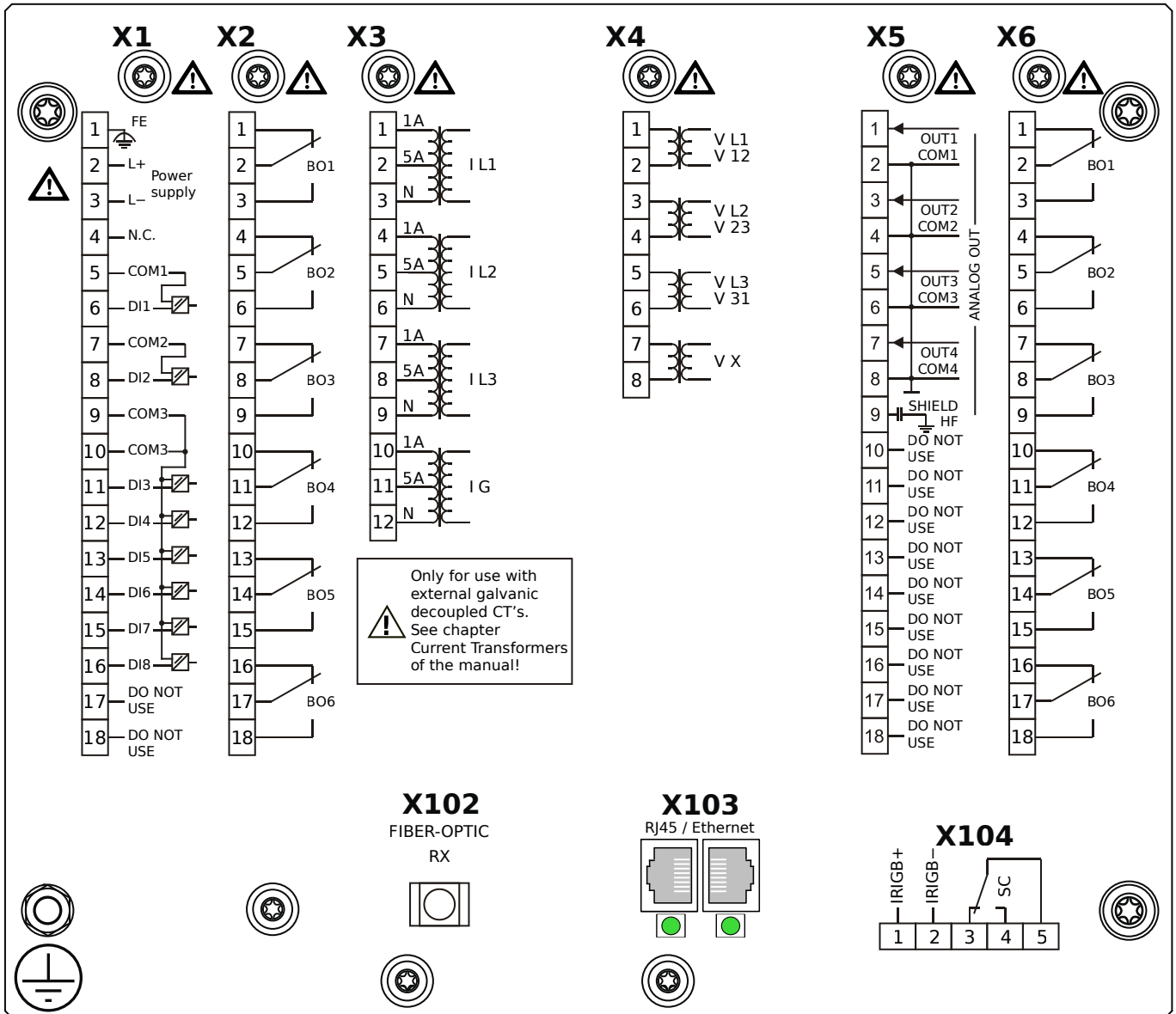

## Housing B2, small display, 19" rack mounting

- + Conformal Coating (for installations in harsh environment)

- X1** – DI8-X1: Wide-range power supply unit, incl. 2 non-grouped digital inputs and 6 grouped digital inputs
- X2** – OR6: Assembly Group with 6 Output Relays (Changeover / Form C)
- X3** – TI: Standard current measuring card
- X4** – TU: Card with 4 voltage transformer measuring inputs (0 ... 800 VAC, under UL: 0 ... 600 VAC)
- X5** – AnO4: Analog Outputs
- X6** – OR6: Assembly Group with 6 Output Relays (Changeover / Form C)
- X102** – Universal Resistance-Temperature Detector (URTD) input, Fiber optics interface, Versatile Link
- X103** – Modbus TCP / IEC 60870-5-104 / DNP3.0 TCP/UDP, Redundant Ethernet interface, 100 Mbit/s, RJ45 (BASE100-FX)
- X104** – IRIG-B00X, incl. System Contact (Supervision Contact)

# MRMV4-2C0BQA

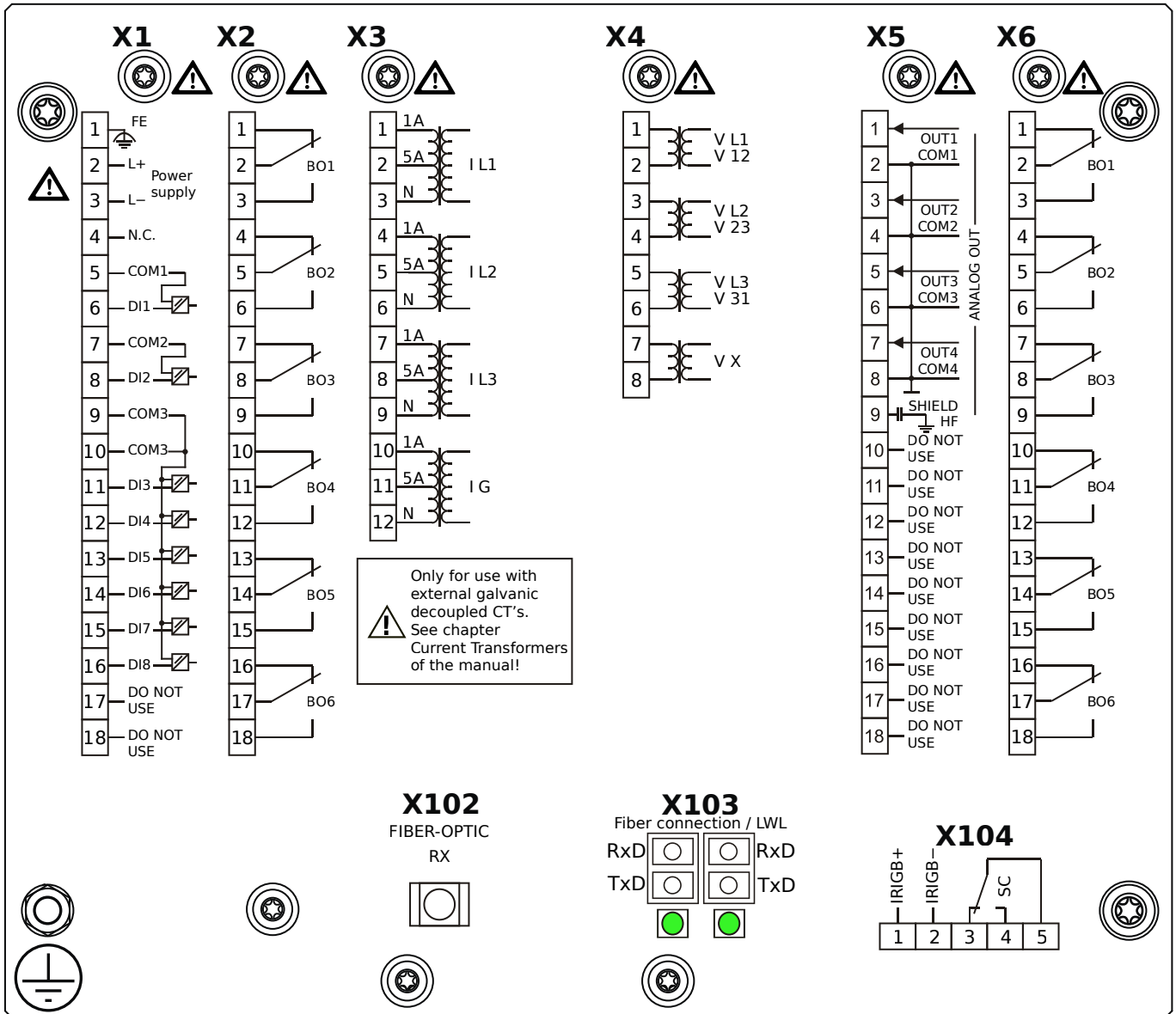

## Housing B2, small display, 19" rack mounting

- X1** – DI8-X1: Wide-range power supply unit, incl. 2 non-grouped digital inputs and 6 grouped digital inputs
- X2** – OR6: Assembly Group with 6 Output Relays (Changeover / Form C)
- X3** – TI: Standard current measuring card
- X4** – TU: Card with 4 voltage transformer measuring inputs (0 ... 800 VAC, under UL: 0 ... 600 VAC)
- X5** – AnO4: Analog Outputs
- X6** – OR6: Assembly Group with 6 Output Relays (Changeover / Form C)
- X102** – Universal Resistance-Temperature Detector (URTD) input, Fiber optics interface, Versatile Link
- X103** – IEC 61850 / Modbus TCP / IEC 60870-5-104 / DNP3.0 TCP/UDP, Redundant Fiber optics interface, LC Connector
- X104** – IRIG-B00X, incl. System Contact (Supervision Contact)

# MRMV4-2C0BQB

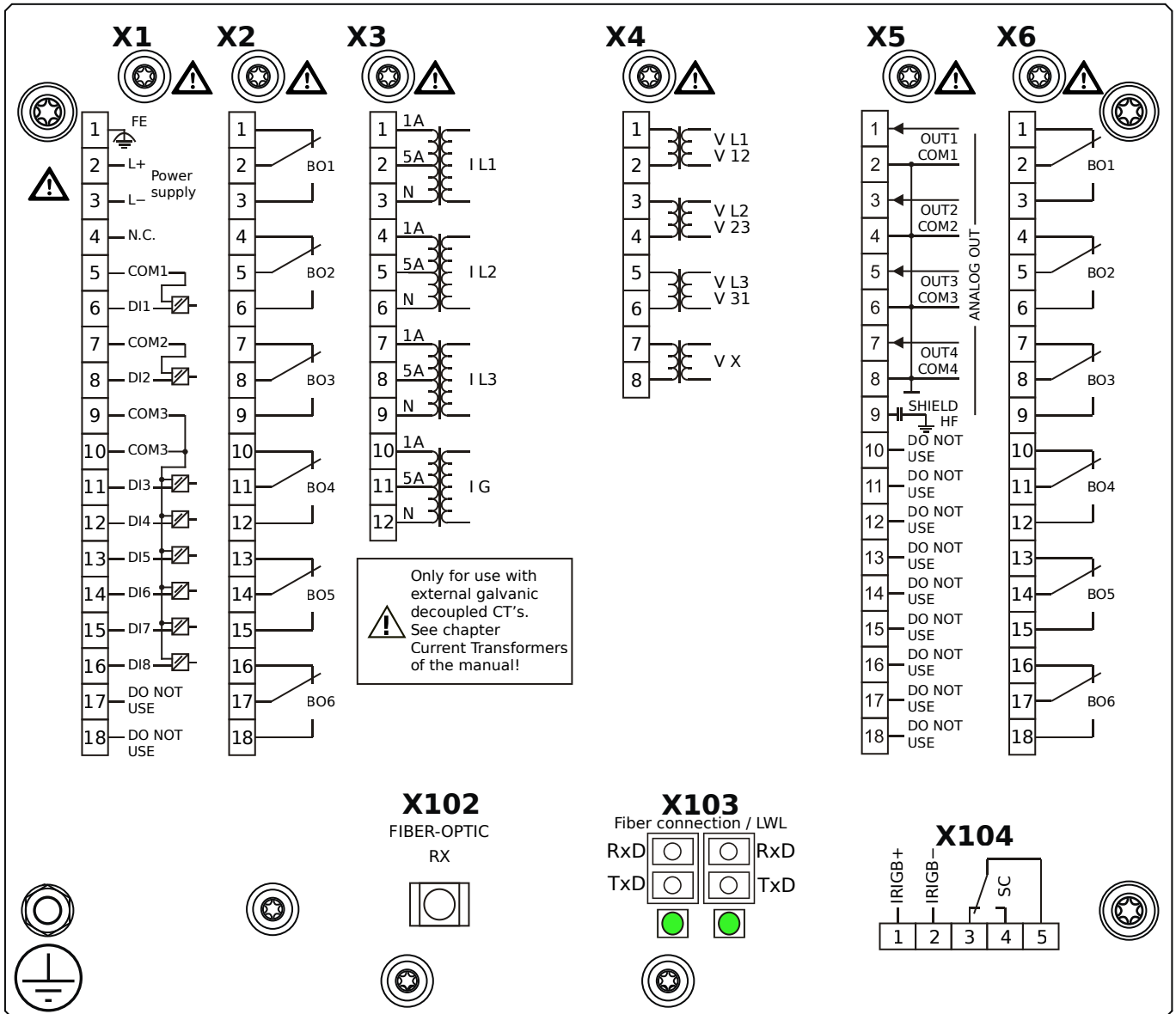

## Housing B2, small display, 19" rack mounting

- + Conformal Coating (for installations in harsh environment)

- X1** – DI8-X1: Wide-range power supply unit, incl. 2 non-grouped digital inputs and 6 grouped digital inputs
- X2** – OR6: Assembly Group with 6 Output Relays (Changeover / Form C)
- X3** – TI: Standard current measuring card
- X4** – TU: Card with 4 voltage transformer measuring inputs (0 ... 800 VAC, under UL: 0 ... 600 VAC)
- X5** – AnO4: Analog Outputs
- X6** – OR6: Assembly Group with 6 Output Relays (Changeover / Form C)
- X102** – Universal Resistance-Temperature Detector (URTD) input, Fiber optics interface, Versatile Link
- X103** – IEC 61850 / Modbus TCP / IEC 60870-5-104 / DNP3.0 TCP/UDP, Redundant Fiber optics interface, LC Connector
- X104** – IRIG-B00X, incl. System Contact (Supervision Contact)

# MRMV4-2C0BRA

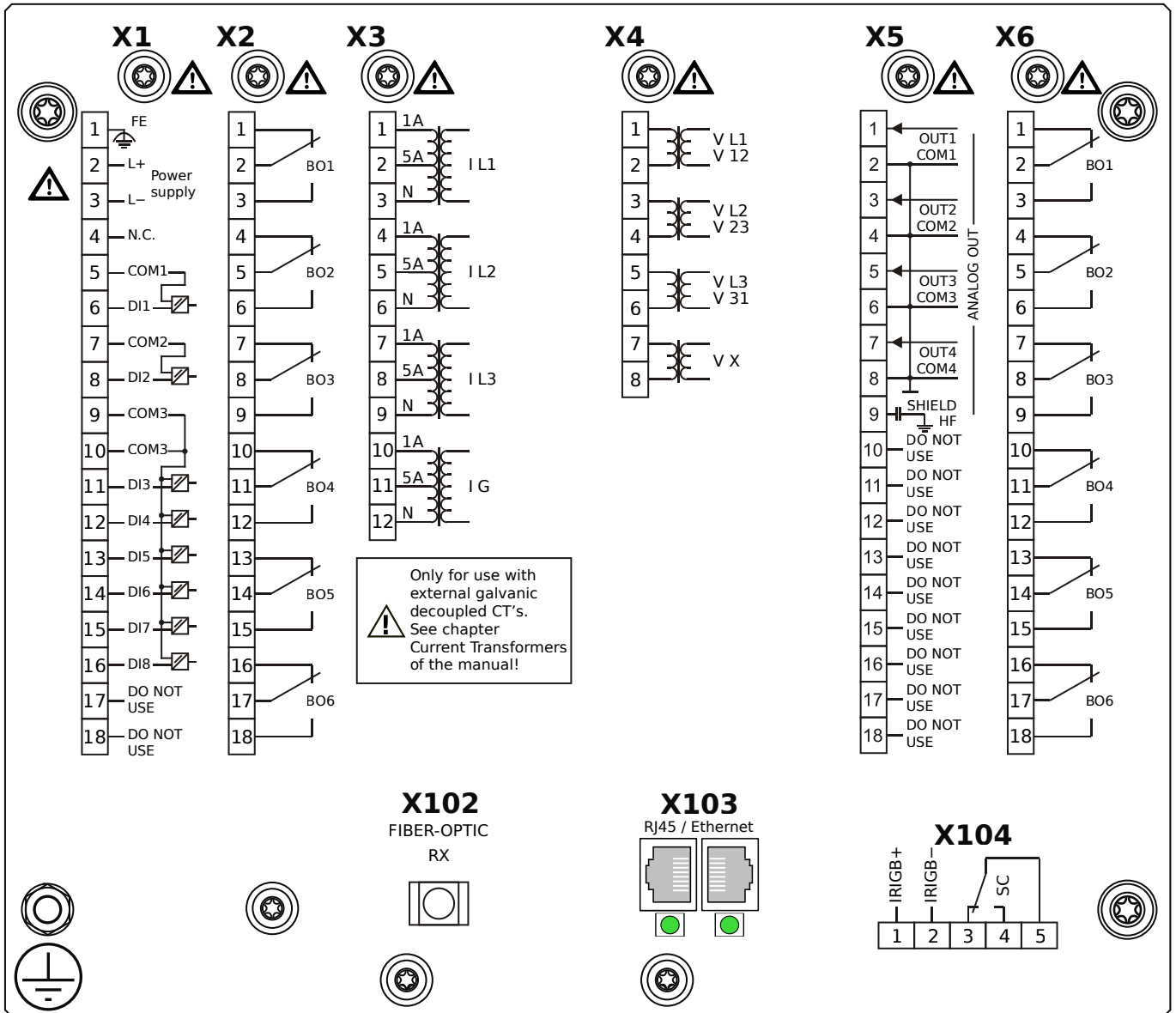

## Housing B2, small display, 19" rack mounting

- X1** – DI8-X1: Wide-range power supply unit, incl. 2 non-grouped digital inputs and 6 grouped digital inputs
- X2** – OR6: Assembly Group with 6 Output Relays (Changeover / Form C)
- X3** – TI: Standard current measuring card
- X4** – TU: Card with 4 voltage transformer measuring inputs (0 ... 800 VAC, under UL: 0 ... 600 VAC)
- X5** – AnO4: Analog Outputs
- X6** – OR6: Assembly Group with 6 Output Relays (Changeover / Form C)
- X102** – Universal Resistance-Temperature Detector (URTD) input, Fiber optics interface, Versatile Link
- X103** – IEC 61850 / Modbus TCP / IEC 60870-5-104 / DNP3.0 TCP/UDP, Redundant Ethernet interface, 100 Mbit/s, RJ45
- X104** – IRIG-B00X, incl. System Contact (Supervision Contact)

# MRMV4-2C0BRB

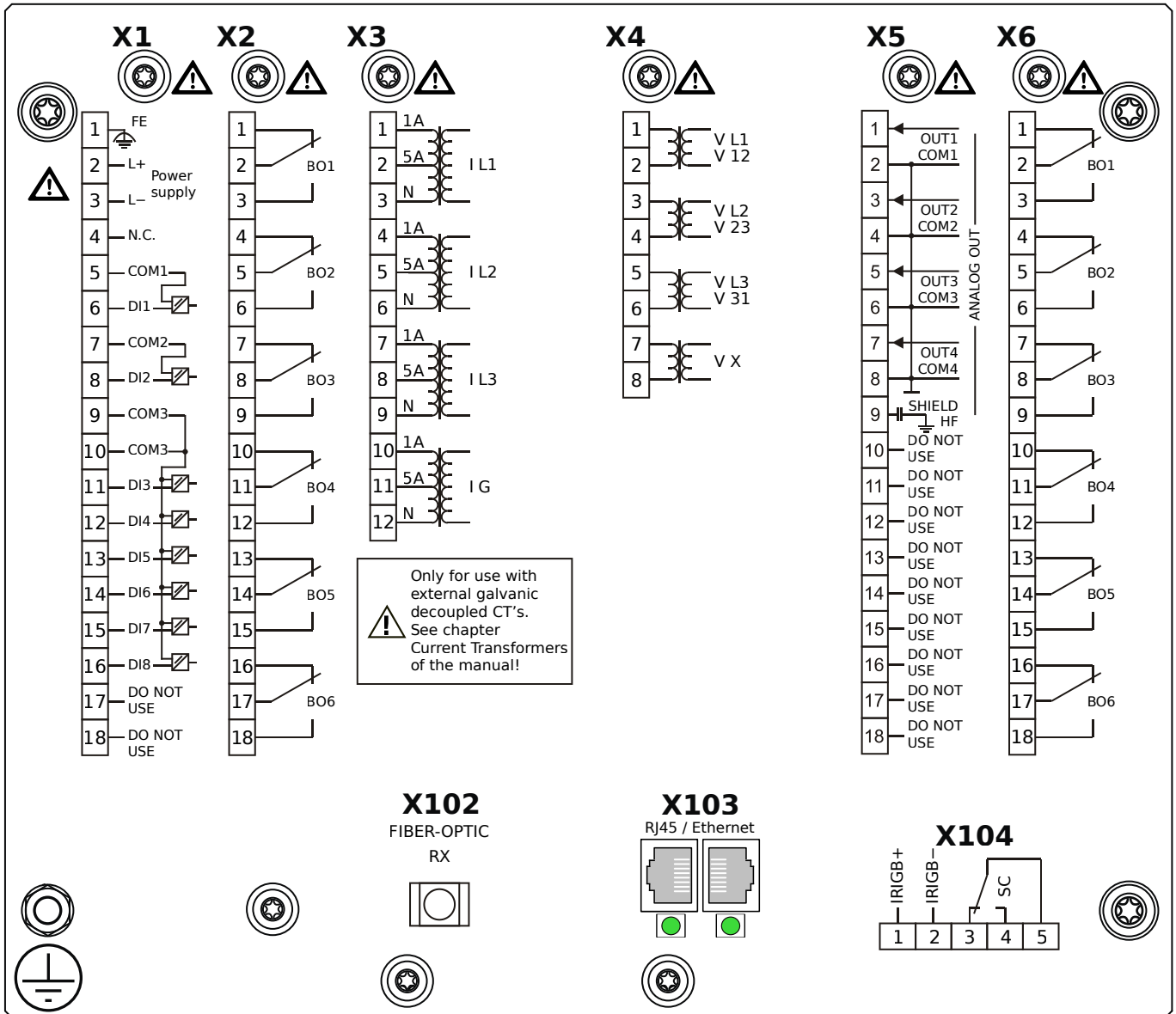

## Housing B2, small display, 19" rack mounting

+ Conformal Coating (for installations in harsh environment)

**X1** – DI8-X1: Wide-range power supply unit, incl. 2 non-grouped digital inputs and 6 grouped digital inputs

**X2** – OR6: Assembly Group with 6 Output Relays (Changeover / Form C)

**X3** – TI: Standard current measuring card

**X4** – TU: Card with 4 voltage transformer measuring inputs (0 ... 800 VAC, under UL: 0 ... 600 VAC)

**X5** – AnO4: Analog Outputs

**X6** – OR6: Assembly Group with 6 Output Relays (Changeover / Form C)

**X102** – Universal Resistance-Temperature Detector (URTD) input, Fiber optics interface, Versatile Link

**X103** – IEC 61850 / Modbus TCP / IEC 60870-5-104 / DNP3.0 TCP/UDP, Redundant Ethernet interface, 100 Mbit/s, RJ45

(BASE100-FX)

**X104** – IRIG-B00X, incl. System Contact (Supervision Contact)

# MRMV4-2C0BTA

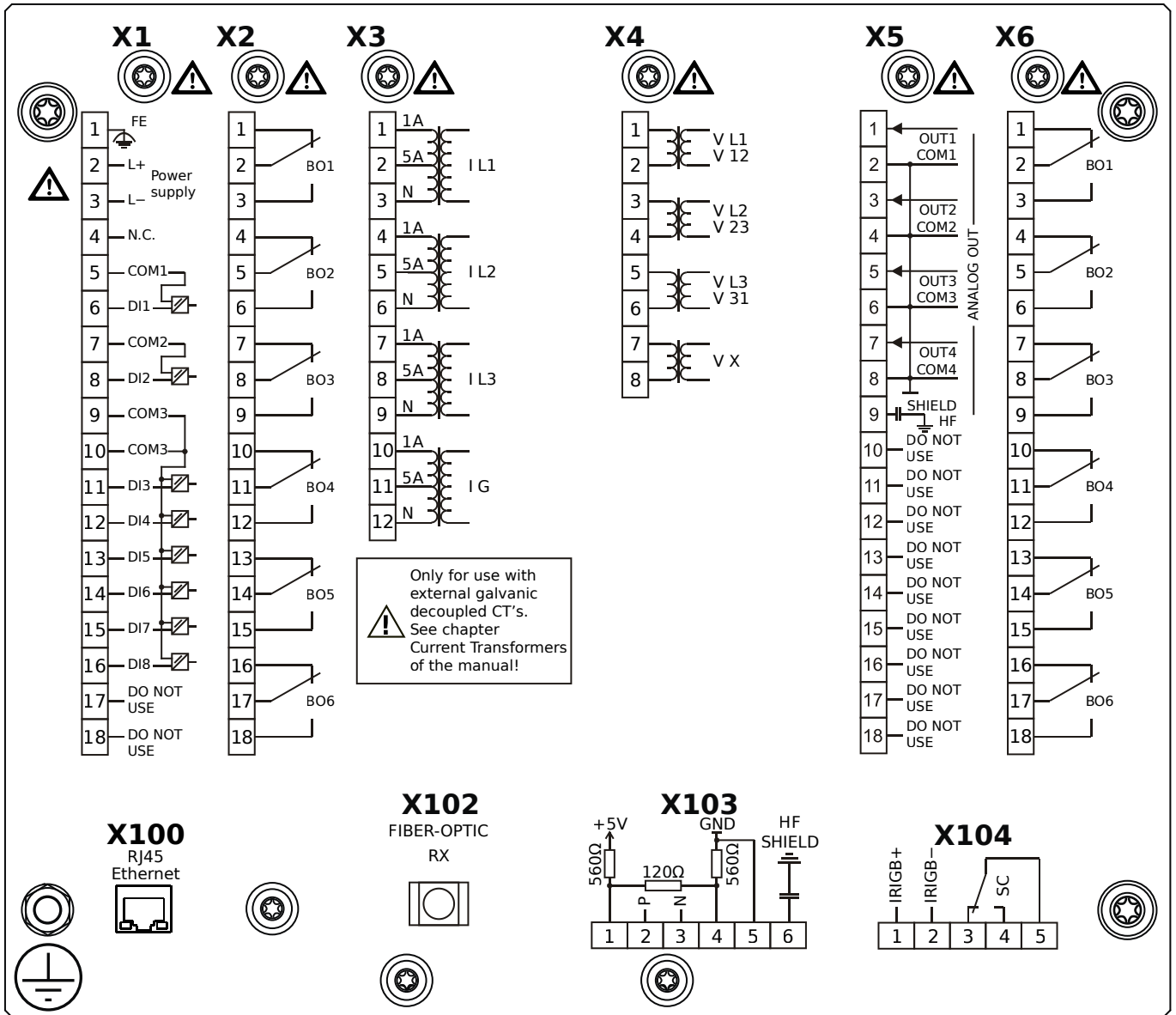

## Housing B2, small display, 19" rack mounting

- X1** – DI8-X1: Wide-range power supply unit, incl. 2 non-grouped digital inputs and 6 grouped digital inputs
- X2** – OR6: Assembly Group with 6 Output Relays (Changeover / Form C)
- X3** – TI: Standard current measuring card
- X4** – TU: Card with 4 voltage transformer measuring inputs (0 ... 800 VAC, under UL: 0 ... 600 VAC)
- X5** – AnO4: Analog Outputs
- X6** – OR6: Assembly Group with 6 Output Relays (Changeover / Form C)
- X100** – IEC 61850 / Modbus TCP / IEC 60870-5-104 / DNP3.0 TCP/UDP, Ethernet interface, 100 Mbit/s, RJ45 (BASE100-FX)
- X102** – Universal Resistance-Temperature Detector (URTD) input, Fiber optics interface, Versatile Link
- X103** – IEC 60870-5-103 / Modbus RTU / DNP3.0 RTU, RS485, Terminals
- X104** – IRIG-B00X, incl. System Contact (Supervision Contact)



# MRMV4-2C0BTB

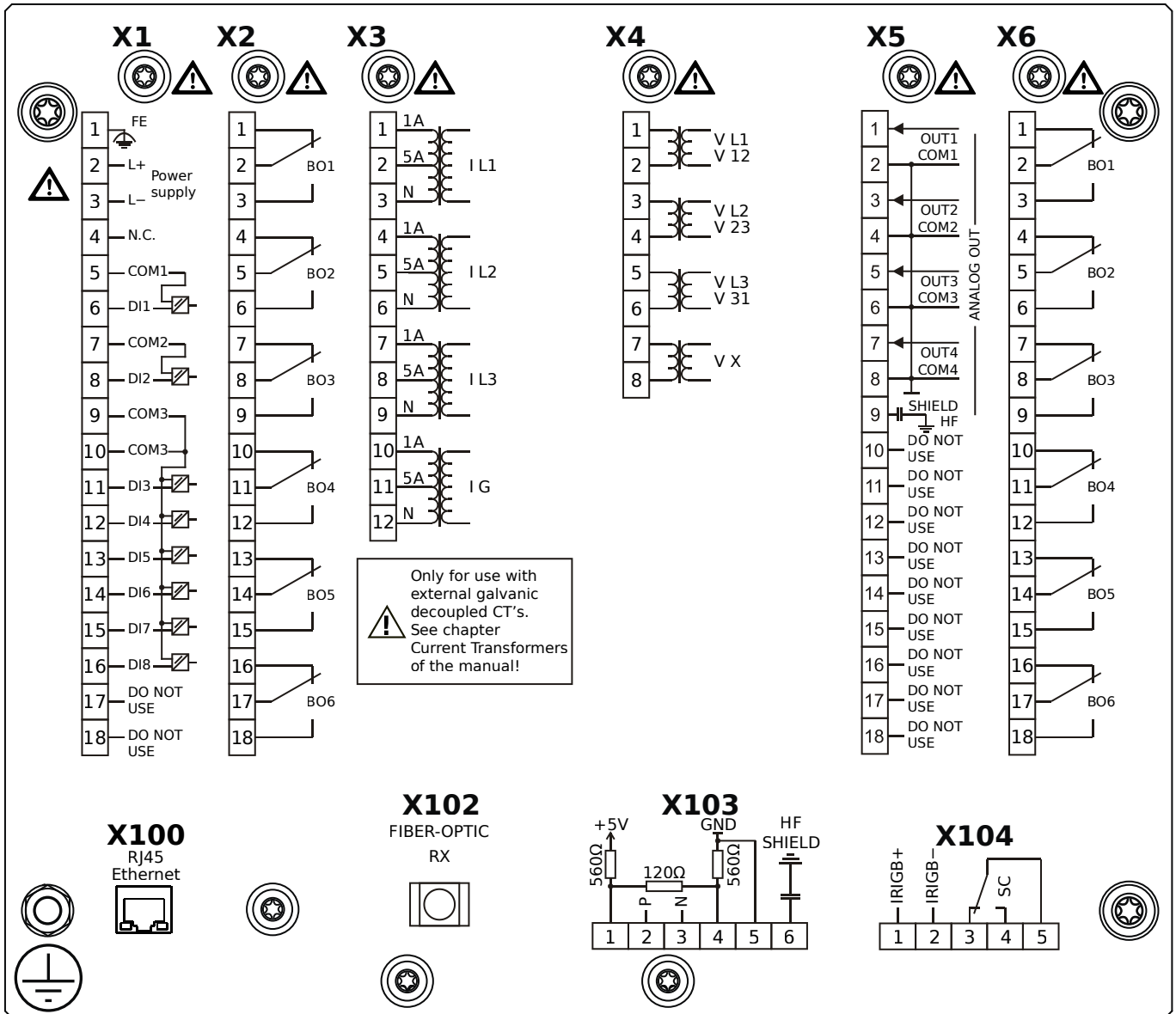

## Housing B2, small display, 19" rack mounting

+ Conformal Coating (for installations in harsh environment)

**X1** – DI8-X1: Wide-range power supply unit, incl. 2 non-grouped digital inputs and 6 grouped digital inputs

**X2** – OR6: Assembly Group with 6 Output Relays (Changeover / Form C)

**X3** – TI: Standard current measuring card

**X4** – TU: Card with 4 voltage transformer measuring inputs (0 ... 800 VAC, under UL: 0 ... 600 VAC)

**X5** – AnO4: Analog Outputs

**X6** – OR6: Assembly Group with 6 Output Relays (Changeover / Form C)

**X100** – IEC 61850 / Modbus TCP / IEC 60870-5-104 / DNP3.0 TCP/UDP, Ethernet interface, 100 Mbit/s, RJ45 (BASE100-

FX)

**X102** – Universal Resistance-Temperature Detector (URTD) input, Fiber optics interface, Versatile Link

**X103** – IEC 60870-5-103 / Modbus RTU / DNP3.0 RTU, RS485, Terminals

**X104** – IRIG-B00X, incl. System Contact (Supervision Contact)

# MRMV4-2C1AAA

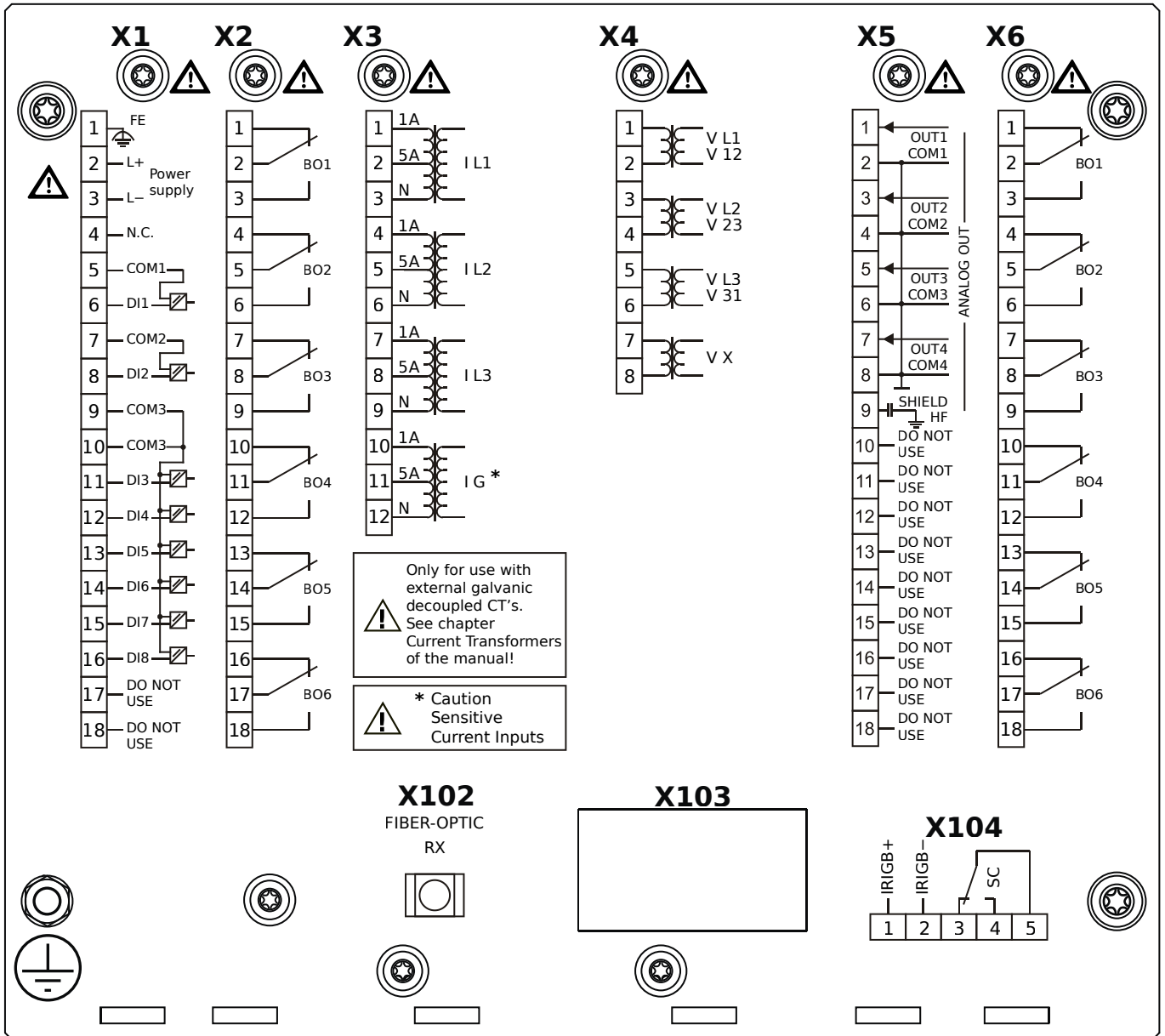

## Housing B2, small display, door mounting

- X1** – DI8-X1: Wide-range power supply unit, incl. 2 non-grouped digital inputs and 6 grouped digital inputs
- X2** – OR6: Assembly Group with 6 Output Relays (Changeover / Form C)
- X3** – TIs: Standard phase current measuring card and sensitive ground current measuring
- X4** – TU: Card with 4 voltage transformer measuring inputs (0 ... 800 VAC, under UL: 0 ... 600 VAC)
- X5** – AnO4: Analog Outputs
- X6** – OR6: Assembly Group with 6 Output Relays (Changeover / Form C)
- X102** – Universal Resistance-Temperature Detector (URTD) input, Fiber optics interface, Versatile Link
- X104** – IRIG-B00X, incl. System Contact (Supervision Contact)

# MRMV4-2C1AAB

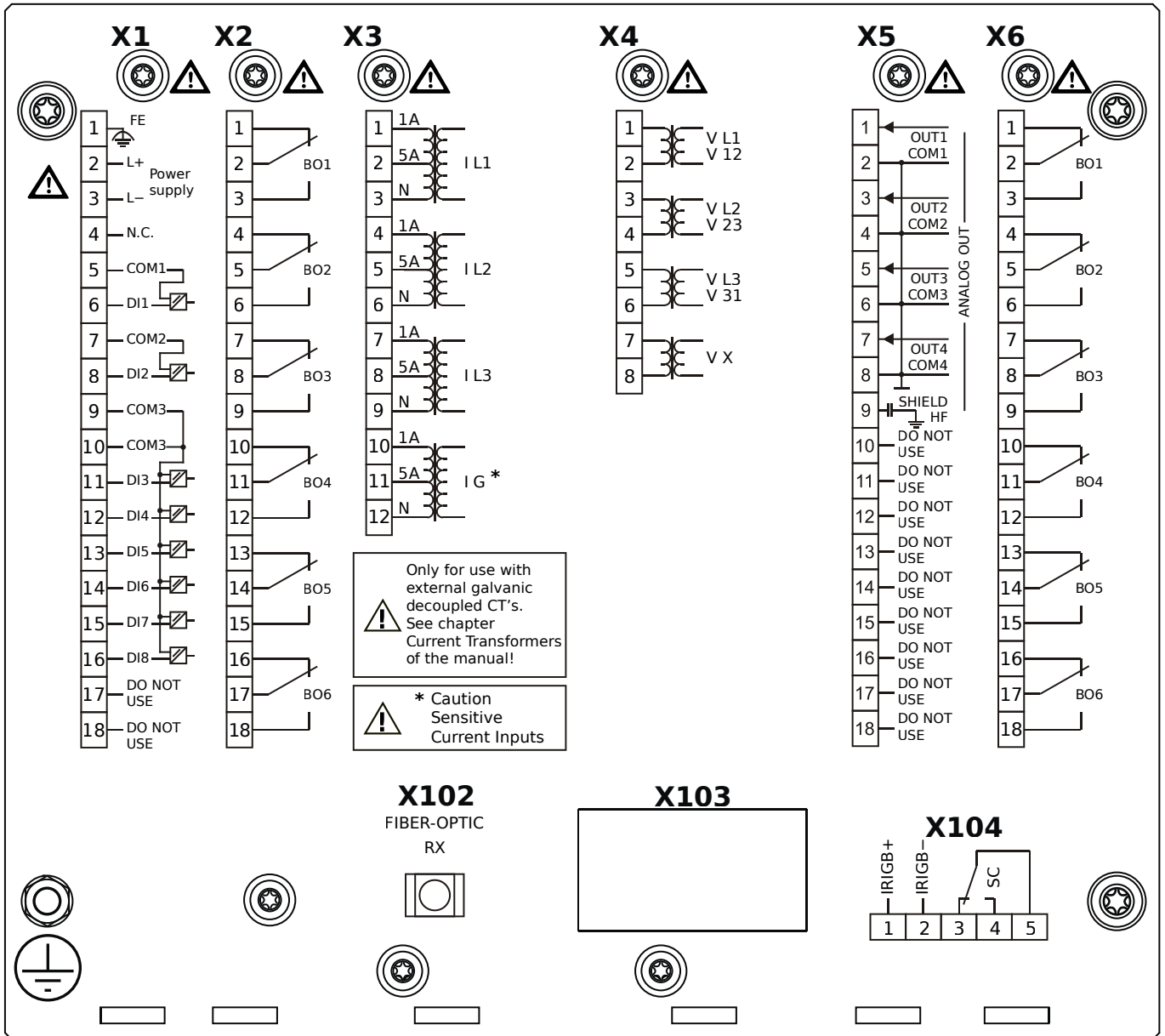

## Housing B2, small display, door mounting

+ Conformal Coating (for installations in harsh environment)

- X1** – DI8-X1: Wide-range power supply unit, incl. 2 non-grouped digital inputs and 6 grouped digital inputs
- X2** – OR6: Assembly Group with 6 Output Relays (Changeover / Form C)
- X3** – TIs: Standard phase current measuring card and sensitive ground current measuring
- X4** – TU: Card with 4 voltage transformer measuring inputs (0 ... 800 VAC, under UL: 0 ... 600 VAC)
- X5** – AnO4: Analog Outputs
- X6** – OR6: Assembly Group with 6 Output Relays (Changeover / Form C)
- X102** – Universal Resistance-Temperature Detector (URTD) input, Fiber optics interface, Versatile Link
- X104** – IRIG-B00X, incl. System Contact (Supervision Contact)

# MRMV4-2C1ABA

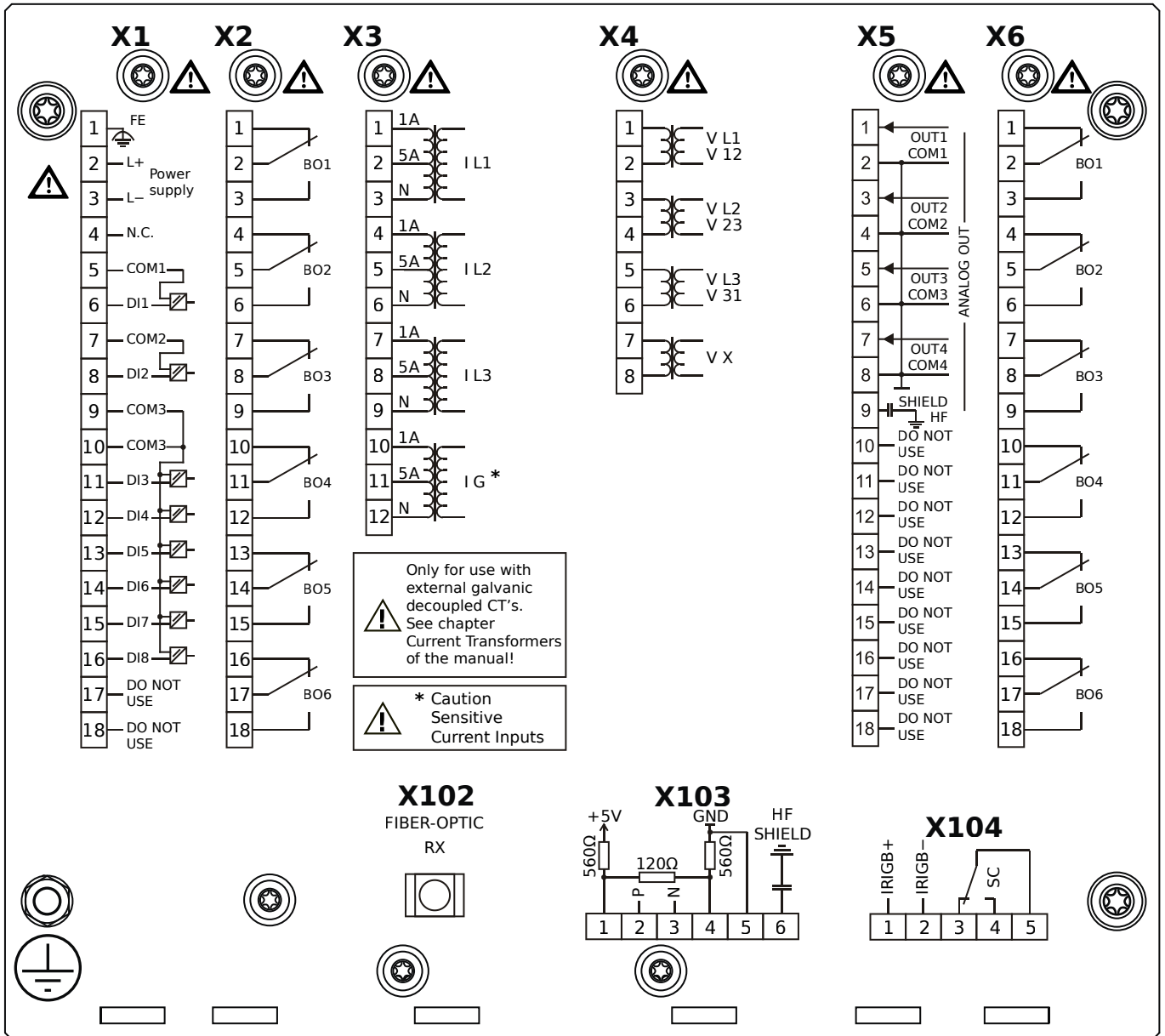

## Housing B2, small display, door mounting

- X1** – DI8-X1: Wide-range power supply unit, incl. 2 non-grouped digital inputs and 6 grouped digital inputs
- X2** – OR6: Assembly Group with 6 Output Relays (Changeover / Form C)
- X3** – TIs: Standard phase current measuring card and sensitive ground current measuring
- X4** – TU: Card with 4 voltage transformer measuring inputs (0 ... 800 VAC, under UL: 0 ... 600 VAC)
- X5** – AnO4: Analog Outputs
- X6** – OR6: Assembly Group with 6 Output Relays (Changeover / Form C)
- X102** – Universal Resistance-Temperature Detector (URTD) input, Fiber optics interface, Versatile Link
- X103** – Modbus RTU / IEC 60870-5-103 / DNP3.0 RTU, RS485, Terminals
- X104** – IRIG-B00X, incl. System Contact (Supervision Contact)

# MRMV4-2C1ABB

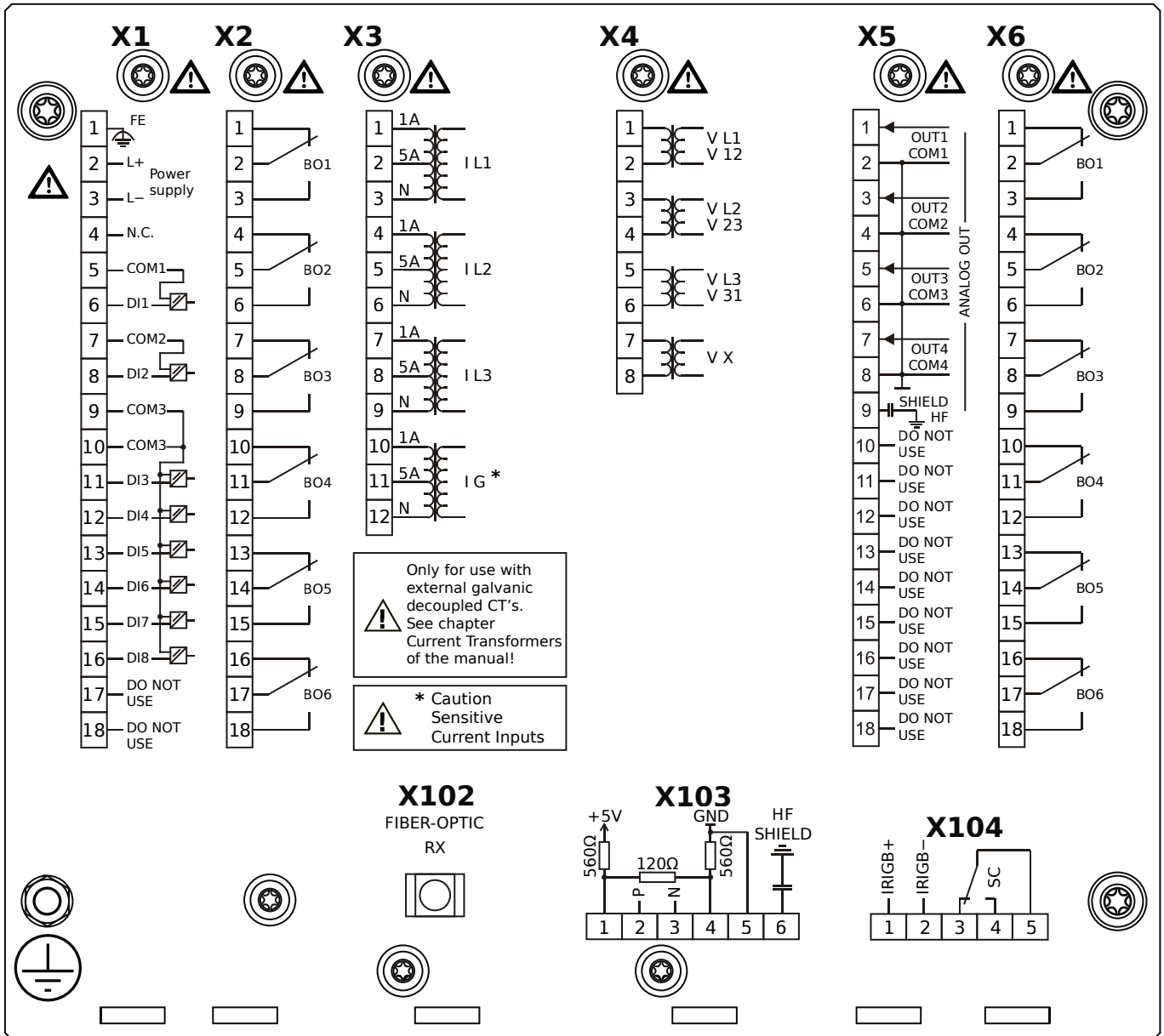

## Housing B2, small display, door mounting

+ Conformal Coating (for installations in harsh environment)

- X1** – DI8-X1: Wide-range power supply unit, incl. 2 non-grouped digital inputs and 6 grouped digital inputs
- X2** – OR6: Assembly Group with 6 Output Relays (Changeover / Form C)
- X3** – TIs: Standard phase current measuring card and sensitive ground current measuring
- X4** – TU: Card with 4 voltage transformer measuring inputs (0 ... 800 VAC, under UL: 0 ... 600 VAC)
- X5** – AnO4: Analog Outputs
- X6** – OR6: Assembly Group with 6 Output Relays (Changeover / Form C)
- X102** – Universal Resistance-Temperature Detector (URTD) input, Fiber optics interface, Versatile Link
- X103** – Modbus RTU / IEC 60870-5-103 / DNP3.0 RTU, RS485, Terminals
- X104** – IRIG-B00X, incl. System Contact (Supervision Contact)

# MRMV4-2C1ACA

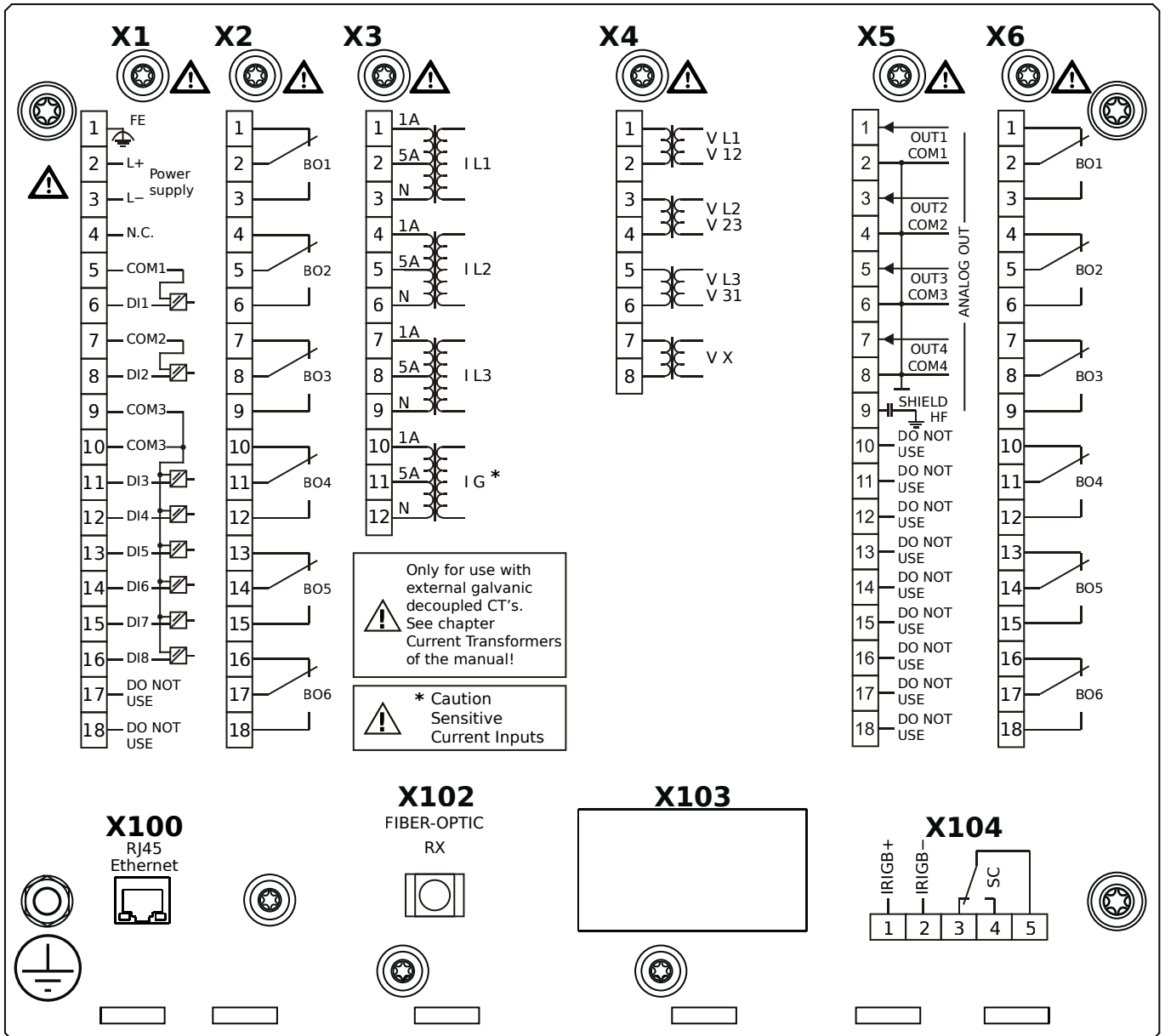

## Housing B2, small display, door mounting

- X1** – DI8-X1: Wide-range power supply unit, incl. 2 non-grouped digital inputs and 6 grouped digital inputs
- X2** – OR6: Assembly Group with 6 Output Relays (Changeover / Form C)
- X3** – TIs: Standard phase current measuring card and sensitive ground current measuring
- X4** – TU: Card with 4 voltage transformer measuring inputs (0 ... 800 VAC, under UL: 0 ... 600 VAC)
- X5** – AnO4: Analog Outputs
- X6** – OR6: Assembly Group with 6 Output Relays (Changeover / Form C)
- X100** – Modbus TCP / IEC 60870-5-104 / DNP3.0 TCP/UDP, Ethernet interface, 100 Mbit/s, RJ45 (BASE100-FX)
- X102** – Universal Resistance-Temperature Detector (URTD) input, Fiber optics interface, Versatile Link
- X104** – IRIG-B00X, incl. System Contact (Supervision Contact)

# MRMV4-2C1ACB

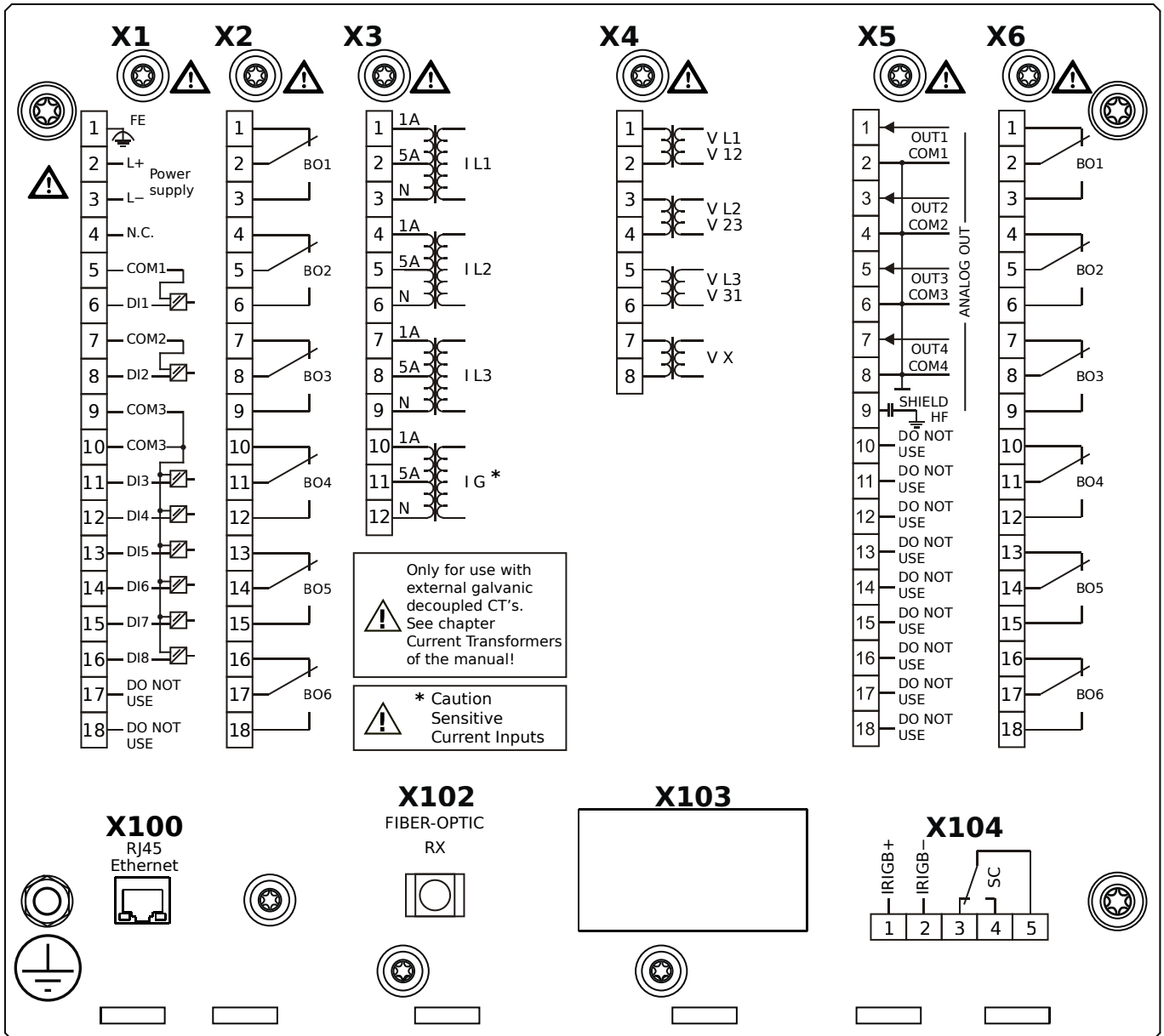

## Housing B2, small display, door mounting

+ Conformal Coating (for installations in harsh environment)

- X1** – DI8-X1: Wide-range power supply unit, incl. 2 non-grouped digital inputs and 6 grouped digital inputs
- X2** – OR6: Assembly Group with 6 Output Relays (Changeover / Form C)
- X3** – TIs: Standard phase current measuring card and sensitive ground current measuring
- X4** – TU: Card with 4 voltage transformer measuring inputs (0 ... 800 VAC, under UL: 0 ... 600 VAC)
- X5** – AnO4: Analog Outputs
- X6** – OR6: Assembly Group with 6 Output Relays (Changeover / Form C)
- X100** – Modbus TCP / IEC 60870-5-104 / DNP3.0 TCP/UDP, Ethernet interface, 100 Mbit/s, RJ45 (BASE100-FX)
- X102** – Universal Resistance-Temperature Detector (URTD) input, Fiber optics interface, Versatile Link
- X104** – IRIG-B00X, incl. System Contact (Supervision Contact)

# MRMV4-2C1ADA

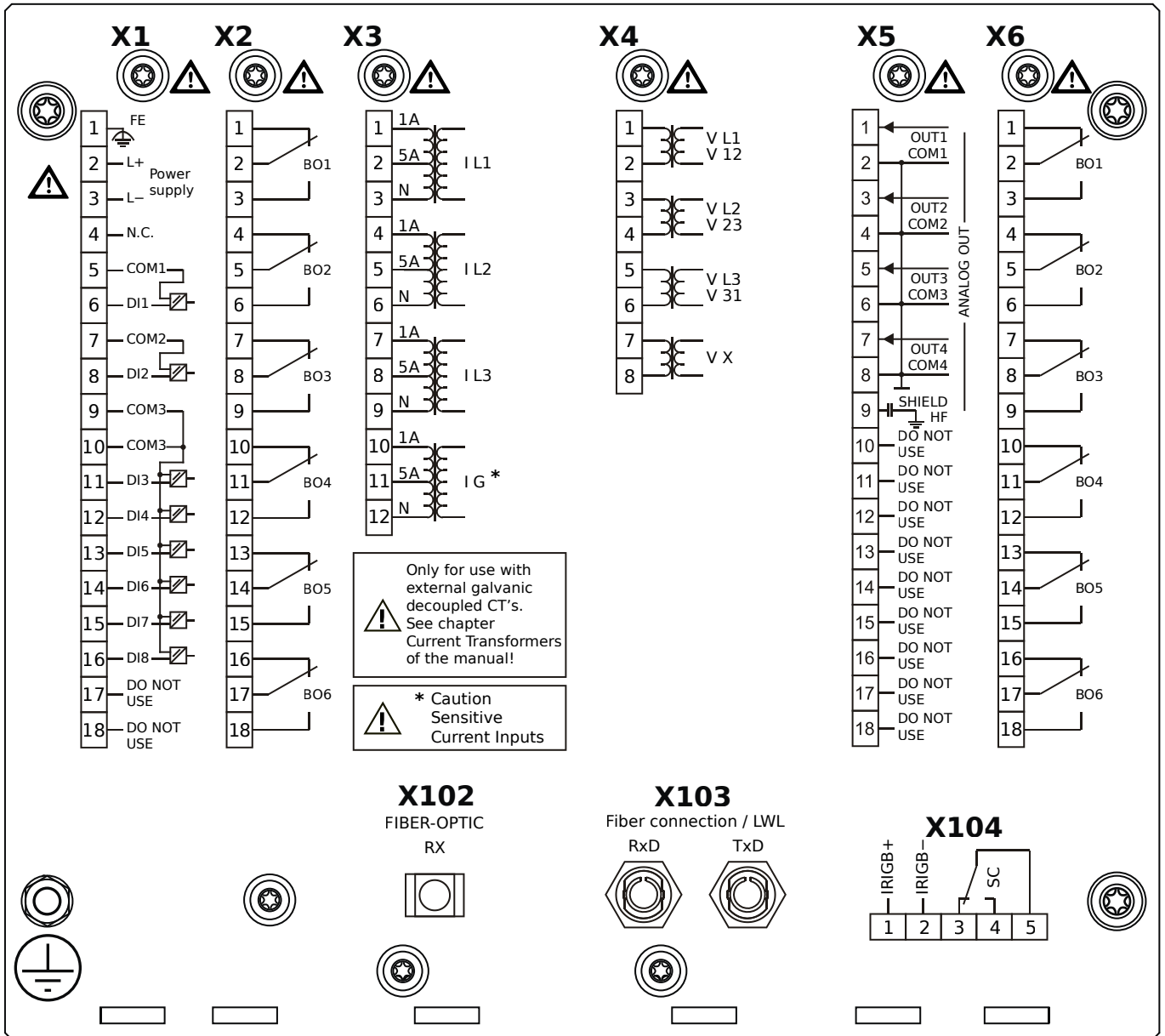

## Housing B2, small display, door mounting

- X1** – DI8-X1: Wide-range power supply unit, incl. 2 non-grouped digital inputs and 6 grouped digital inputs
- X2** – OR6: Assembly Group with 6 Output Relays (Changeover / Form C)
- X3** – TIs: Standard phase current measuring card and sensitive ground current measuring
- X4** – TU: Card with 4 voltage transformer measuring inputs (0 ... 800 VAC, under UL: 0 ... 600 VAC)
- X5** – AnO4: Analog Outputs
- X6** – OR6: Assembly Group with 6 Output Relays (Changeover / Form C)
- X102** – Universal Resistance-Temperature Detector (URTD) input, Fiber optics interface, Versatile Link
- X103** – Profibus-DP, Fiber optics interface, ST Connector
- X104** – IRIG-B00X, incl. System Contact (Supervision Contact)



# MRMV4-2C1ADB

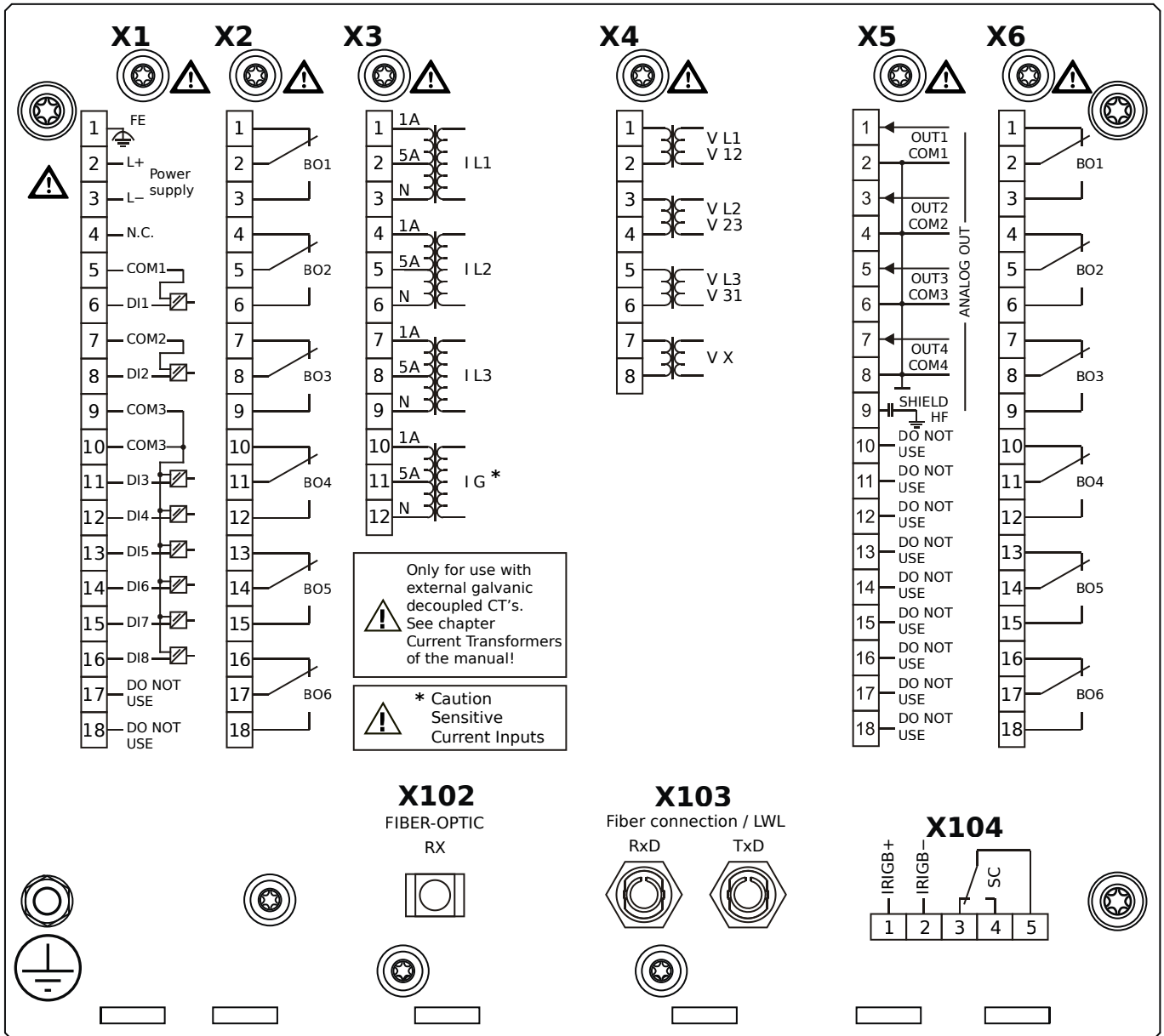

## Housing B2, small display, door mounting

+ Conformal Coating (for installations in harsh environment)

- X1** – DI8-X1: Wide-range power supply unit, incl. 2 non-grouped digital inputs and 6 grouped digital inputs
- X2** – OR6: Assembly Group with 6 Output Relays (Changeover / Form C)
- X3** – TIs: Standard phase current measuring card and sensitive ground current measuring
- X4** – TU: Card with 4 voltage transformer measuring inputs (0 ... 800 VAC, under UL: 0 ... 600 VAC)
- X5** – AnO4: Analog Outputs
- X6** – OR6: Assembly Group with 6 Output Relays (Changeover / Form C)
- X102** – Universal Resistance-Temperature Detector (URTD) input, Fiber optics interface, Versatile Link
- X103** – Profibus-DP, Fiber optics interface, ST Connector
- X104** – IRIG-B00X, incl. System Contact (Supervision Contact)

# MRMV4-2C1AEA

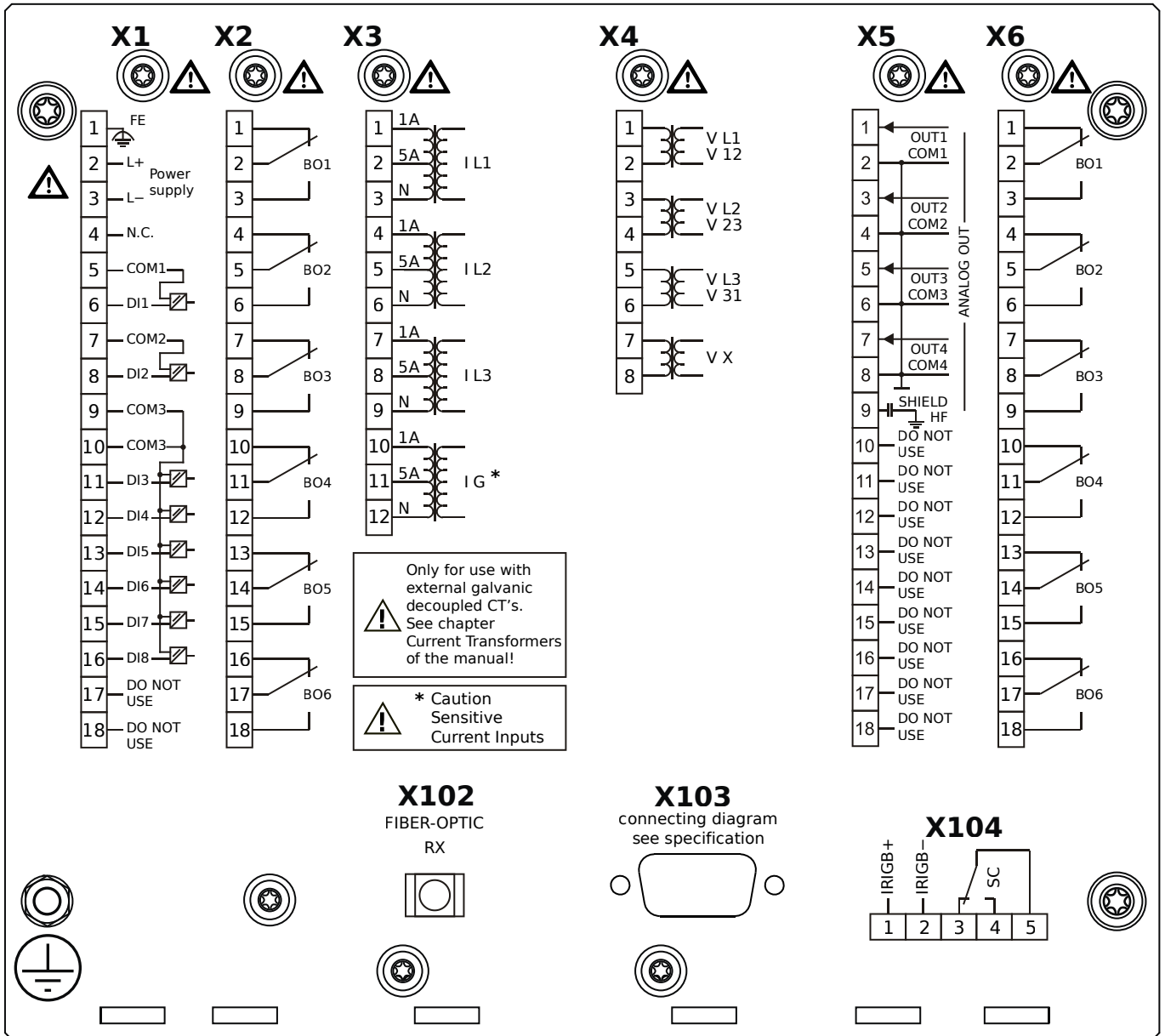

## Housing B2, small display, door mounting

- X1** – DI8-X1: Wide-range power supply unit, incl. 2 non-grouped digital inputs and 6 grouped digital inputs
- X2** – OR6: Assembly Group with 6 Output Relays (Changeover / Form C)
- X3** – TIs: Standard phase current measuring card and sensitive ground current measuring
- X4** – TU: Card with 4 voltage transformer measuring inputs (0 ... 800 VAC, under UL: 0 ... 600 VAC)
- X5** – AnO4: Analog Outputs
- X6** – OR6: Assembly Group with 6 Output Relays (Changeover / Form C)
- X102** – Universal Resistance-Temperature Detector (URTD) input, Fiber optics interface, Versatile Link
- X103** – Profibus-DP, RS485, D-SUB
- X104** – IRIG-B00X, incl. System Contact (Supervision Contact)

# MRMV4-2C1AEB

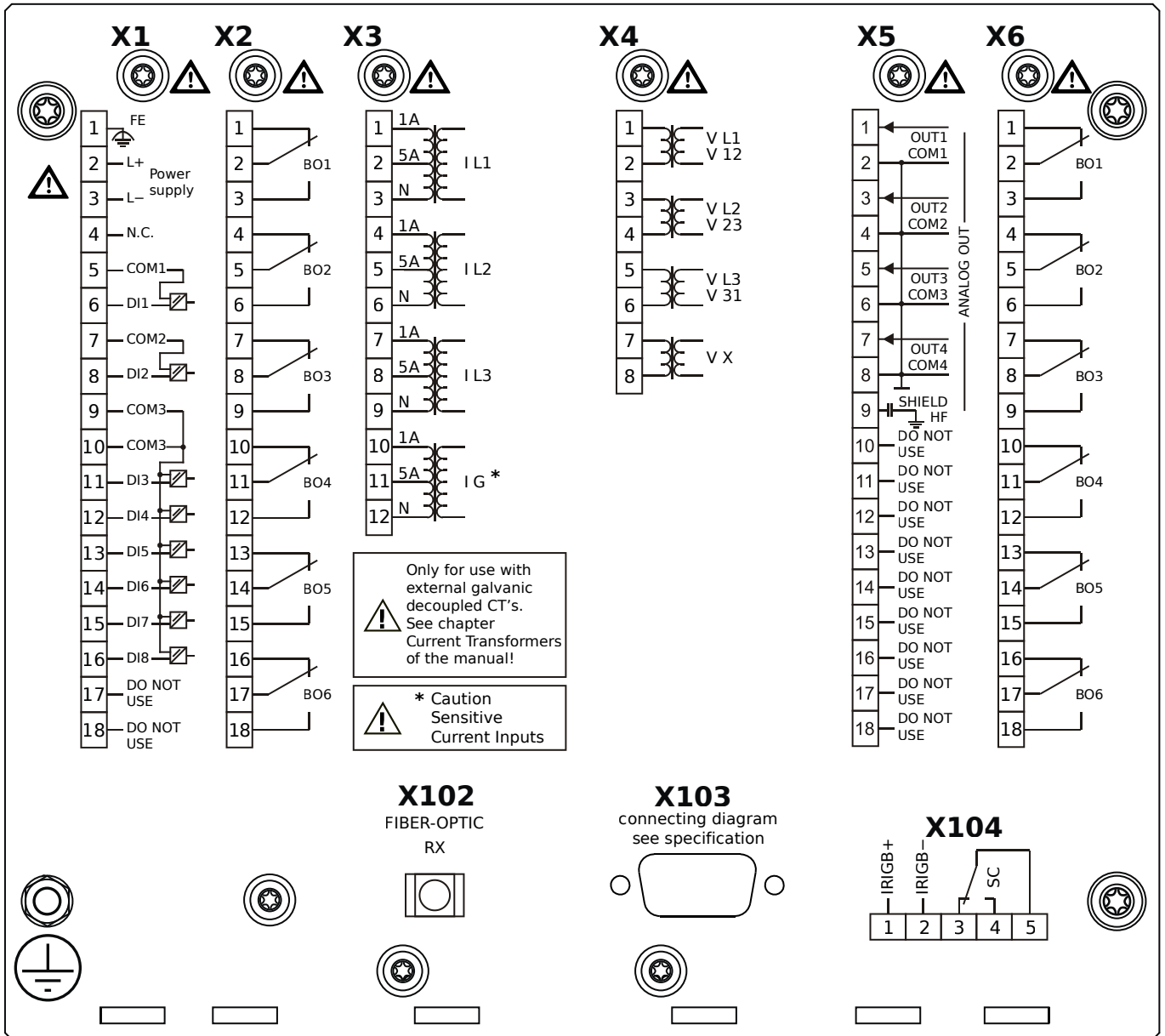

## Housing B2, small display, door mounting

+ Conformal Coating (for installations in harsh environment)

- X1** – DI8-X1: Wide-range power supply unit, incl. 2 non-grouped digital inputs and 6 grouped digital inputs
- X2** – OR6: Assembly Group with 6 Output Relays (Changeover / Form C)
- X3** – TIs: Standard phase current measuring card and sensitive ground current measuring
- X4** – TU: Card with 4 voltage transformer measuring inputs (0 ... 800 VAC, under UL: 0 ... 600 VAC)
- X5** – AnO4: Analog Outputs
- X6** – OR6: Assembly Group with 6 Output Relays (Changeover / Form C)
- X102** – Universal Resistance-Temperature Detector (URTD) input, Fiber optics interface, Versatile Link
- X103** – Profibus-DP, RS485, D-SUB
- X104** – IRIG-B00X, incl. System Contact (Supervision Contact)

# MRMV4-2C1AFA

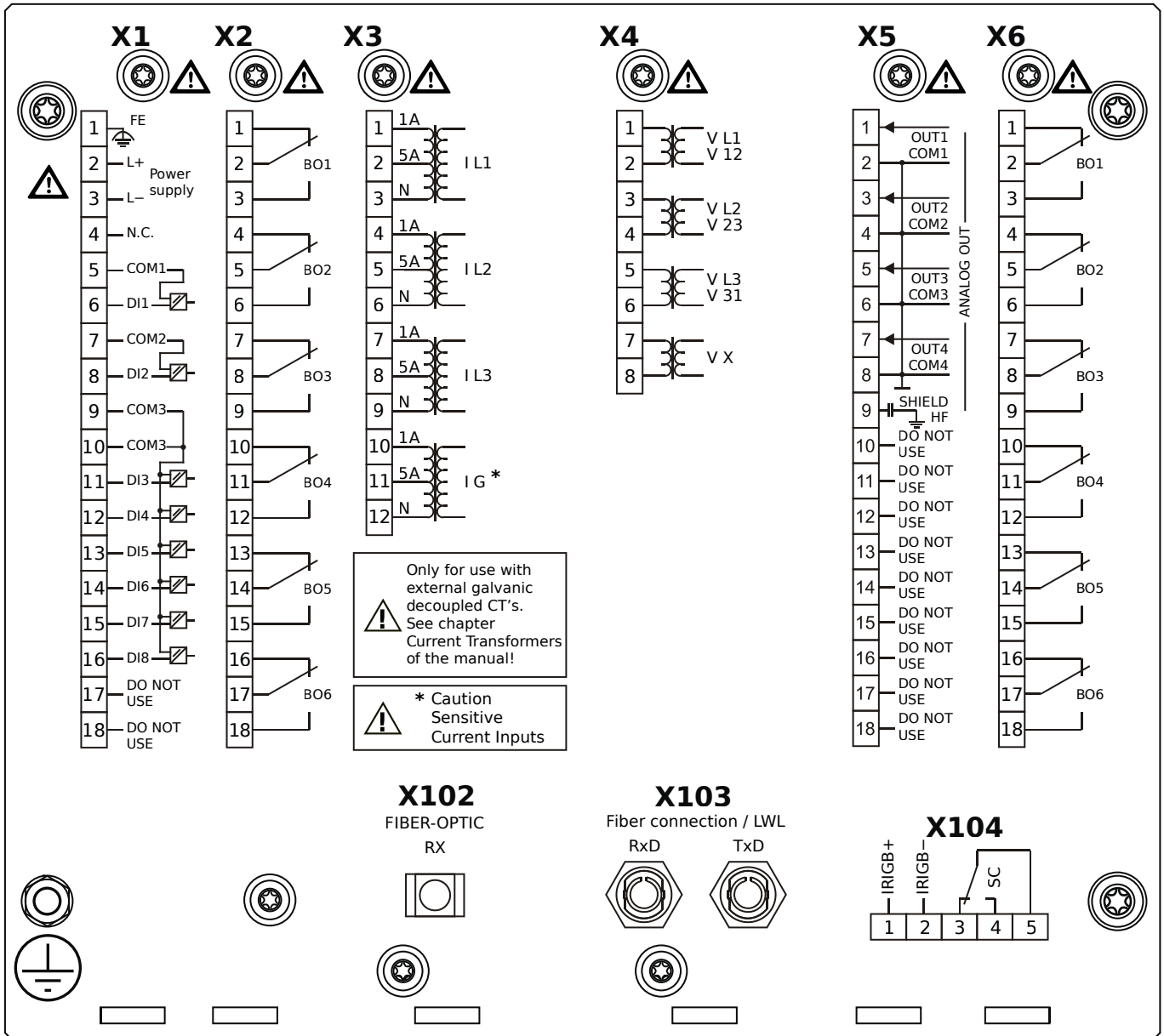

## Housing B2, small display, door mounting

- X1** – DI8-X1: Wide-range power supply unit, incl. 2 non-grouped digital inputs and 6 grouped digital inputs
- X2** – OR6: Assembly Group with 6 Output Relays (Changeover / Form C)
- X3** – TIs: Standard phase current measuring card and sensitive ground current measuring
- X4** – TU: Card with 4 voltage transformer measuring inputs (0 ... 800 VAC, under UL: 0 ... 600 VAC)
- X5** – AnO4: Analog Outputs
- X6** – OR6: Assembly Group with 6 Output Relays (Changeover / Form C)
- X102** – Universal Resistance-Temperature Detector (URTD) input, Fiber optics interface, Versatile Link
- X103** – Modbus RTU / IEC 60870-5-103 / DNP3.0 RTU, Fiber optics interface, ST Connector
- X104** – IRIG-B00X, incl. System Contact (Supervision Contact)

# MRMV4-2C1AFB

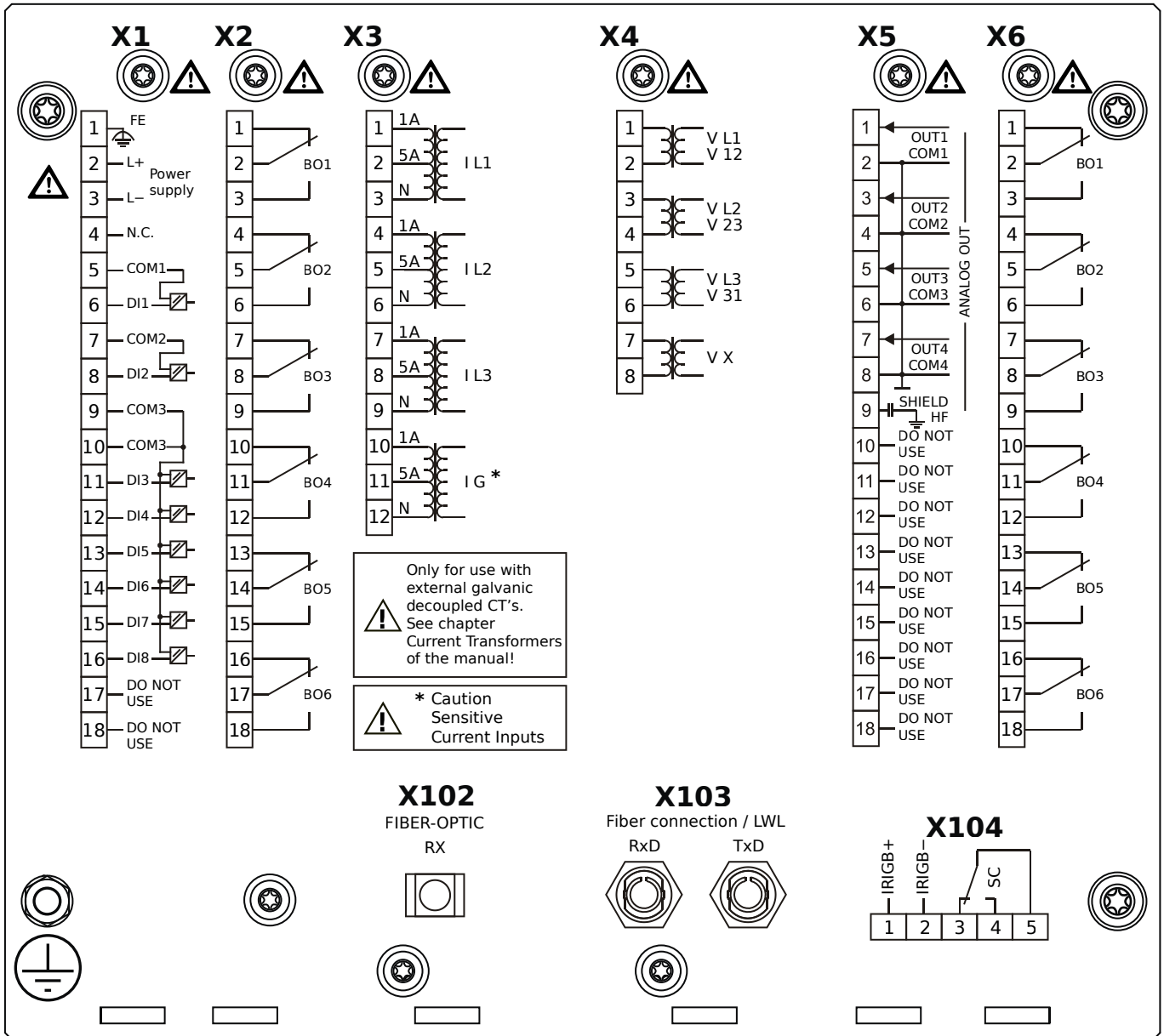

## Housing B2, small display, door mounting

+ Conformal Coating (for installations in harsh environment)

- X1** – DI8-X1: Wide-range power supply unit, incl. 2 non-grouped digital inputs and 6 grouped digital inputs
- X2** – OR6: Assembly Group with 6 Output Relays (Changeover / Form C)
- X3** – TIs: Standard phase current measuring card and sensitive ground current measuring
- X4** – TU: Card with 4 voltage transformer measuring inputs (0 ... 800 VAC, under UL: 0 ... 600 VAC)
- X5** – AnO4: Analog Outputs
- X6** – OR6: Assembly Group with 6 Output Relays (Changeover / Form C)
- X102** – Universal Resistance-Temperature Detector (URTD) input, Fiber optics interface, Versatile Link
- X103** – Modbus RTU / IEC 60870-5-103 / DNP3.0 RTU, Fiber optics interface, ST Connector
- X104** – IRIG-B00X, incl. System Contact (Supervision Contact)

# MRMV4-2C1AGA

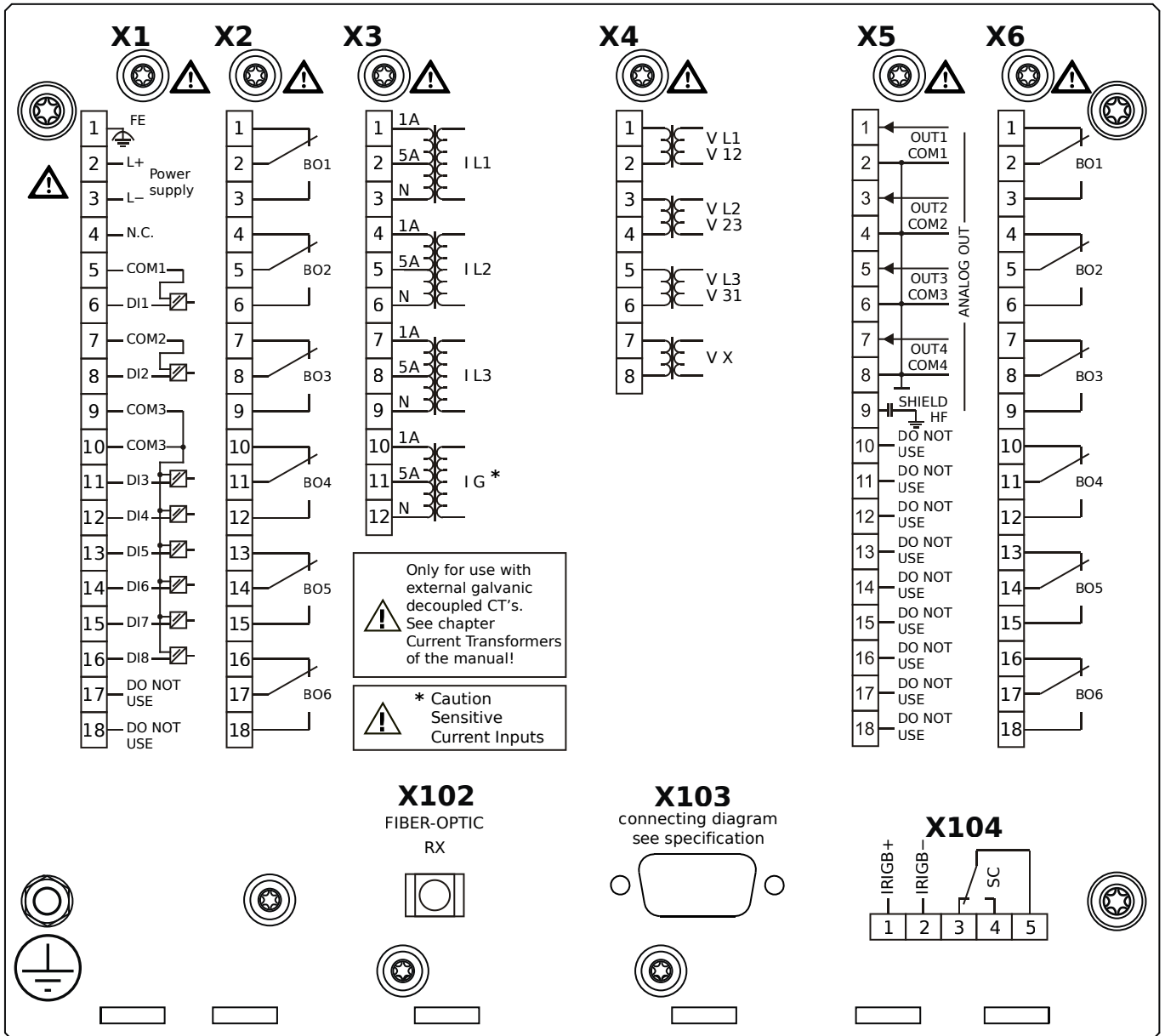

## Housing B2, small display, door mounting

- X1** – DI8-X1: Wide-range power supply unit, incl. 2 non-grouped digital inputs and 6 grouped digital inputs
- X2** – OR6: Assembly Group with 6 Output Relays (Changeover / Form C)
- X3** – TIs: Standard phase current measuring card and sensitive ground current measuring
- X4** – TU: Card with 4 voltage transformer measuring inputs (0 ... 800 VAC, under UL: 0 ... 600 VAC)
- X5** – AnO4: Analog Outputs
- X6** – OR6: Assembly Group with 6 Output Relays (Changeover / Form C)
- X102** – Universal Resistance-Temperature Detector (URTD) input, Fiber optics interface, Versatile Link
- X103** – Modbus RTU / IEC 60870-5-103 / DNP3.0 RTU, RS485, D-SUB
- X104** – IRIG-B00X, incl. System Contact (Supervision Contact)

# MRMV4-2C1AGB

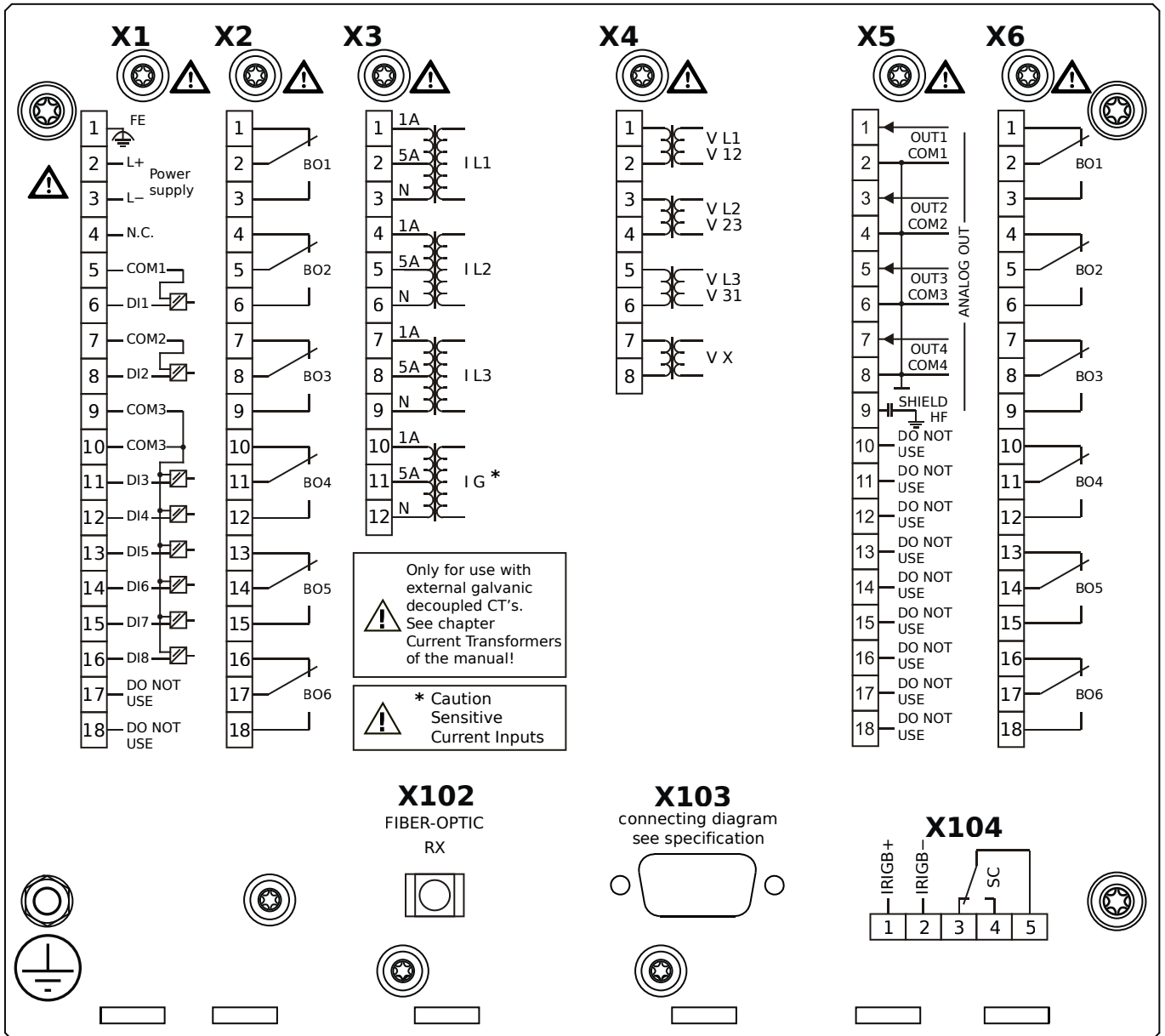

## Housing B2, small display, door mounting

+ Conformal Coating (for installations in harsh environment)

- X1** – DI8-X1: Wide-range power supply unit, incl. 2 non-grouped digital inputs and 6 grouped digital inputs
- X2** – OR6: Assembly Group with 6 Output Relays (Changeover / Form C)
- X3** – TIs: Standard phase current measuring card and sensitive ground current measuring
- X4** – TU: Card with 4 voltage transformer measuring inputs (0 ... 800 VAC, under UL: 0 ... 600 VAC)
- X5** – AnO4: Analog Outputs
- X6** – OR6: Assembly Group with 6 Output Relays (Changeover / Form C)
- X102** – Universal Resistance-Temperature Detector (URTD) input, Fiber optics interface, Versatile Link
- X103** – Modbus RTU / IEC 60870-5-103 / DNP3.0 RTU, RS485, D-SUB
- X104** – IRIG-B00X, incl. System Contact (Supervision Contact)

# MRMV4-2C1AHA

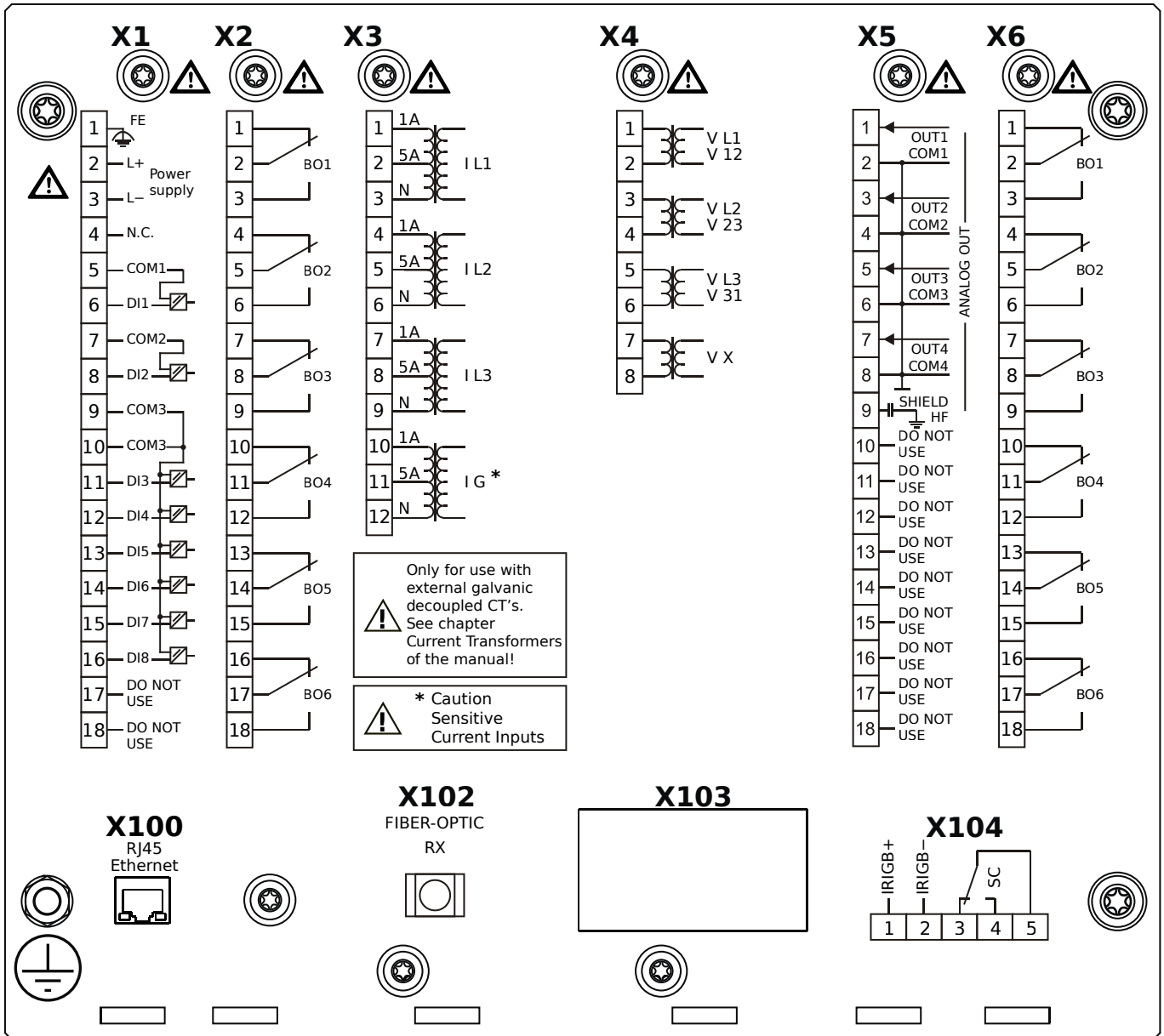

## Housing B2, small display, door mounting

- X1** – DI8-X1: Wide-range power supply unit, incl. 2 non-grouped digital inputs and 6 grouped digital inputs
- X2** – OR6: Assembly Group with 6 Output Relays (Changeover / Form C)
- X3** – TIs: Standard phase current measuring card and sensitive ground current measuring
- X4** – TU: Card with 4 voltage transformer measuring inputs (0 ... 800 VAC, under UL: 0 ... 600 VAC)
- X5** – AnO4: Analog Outputs
- X6** – OR6: Assembly Group with 6 Output Relays (Changeover / Form C)
- X100** – IEC 61850 / Modbus TCP / IEC 60870-5-104 / DNP3.0 TCP/UDP, Ethernet interface, 100 Mbit/s, RJ45 (BASE100-FX)
- X102** – Universal Resistance-Temperature Detector (URTD) input, Fiber optics interface, Versatile Link
- X104** – IRIG-B00X, incl. System Contact (Supervision Contact)



# MRMV4-2C1AHB

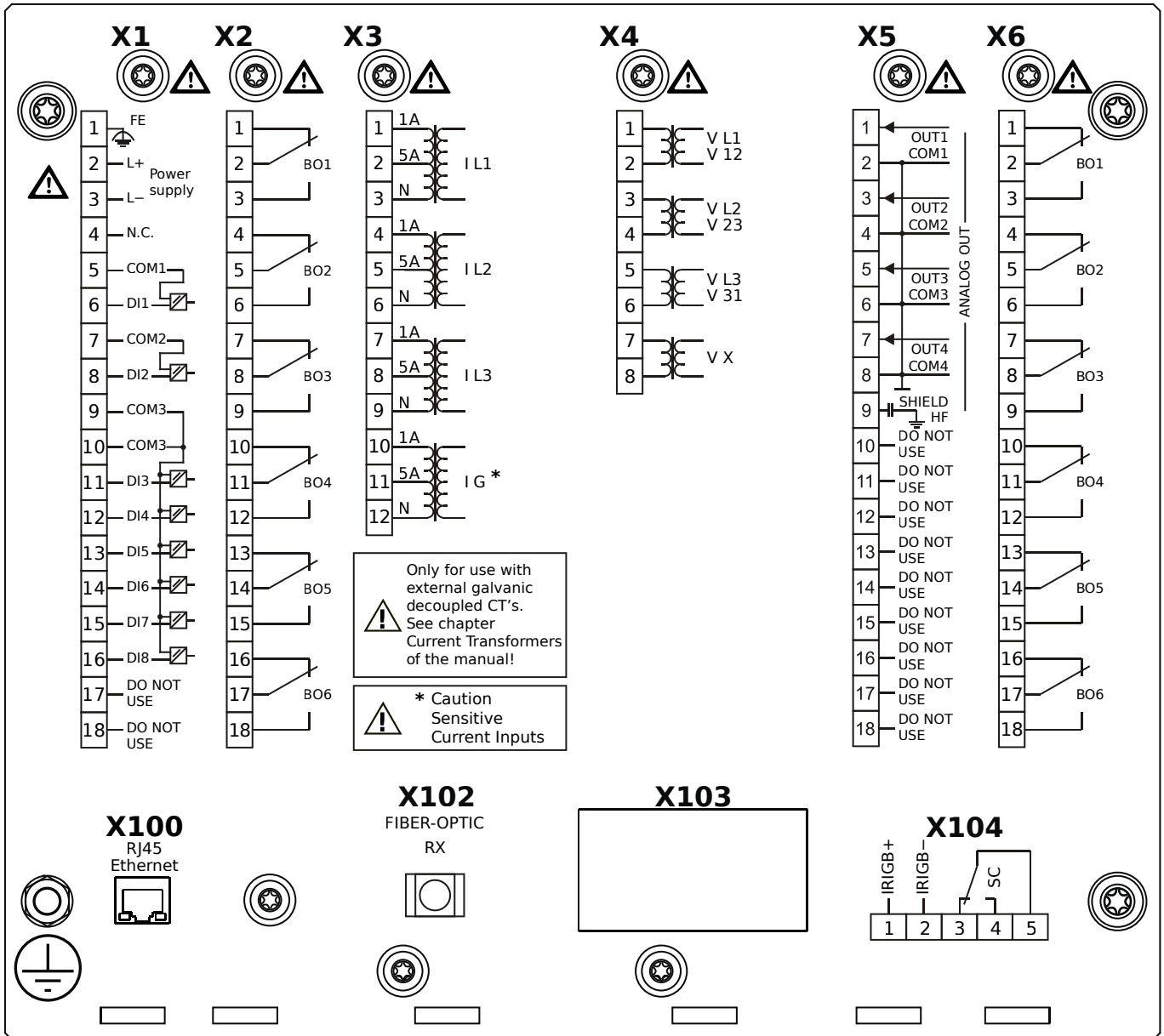

## Housing B2, small display, door mounting

+ Conformal Coating (for installations in harsh environment)

**X1** – DI8-X1: Wide-range power supply unit, incl. 2 non-grouped digital inputs and 6 grouped digital inputs

**X2** – OR6: Assembly Group with 6 Output Relays (Changeover / Form C)

**X3** – TIs: Standard phase current measuring card and sensitive ground current measuring

**X4** – TU: Card with 4 voltage transformer measuring inputs (0 ... 800 VAC, under UL: 0 ... 600 VAC)

**X5** – AnO4: Analog Outputs

**X6** – OR6: Assembly Group with 6 Output Relays (Changeover / Form C)

**X100** – IEC 61850 / Modbus TCP / IEC 60870-5-104 / DNP3.0 TCP/UDP, Ethernet interface, 100 Mbit/s, RJ45 (BASE100-

FX)

**X102** – Universal Resistance-Temperature Detector (URTD) input, Fiber optics interface, Versatile Link

**X104** – IRIG-B00X, incl. System Contact (Supervision Contact)

# MRMV4-2C1AIA

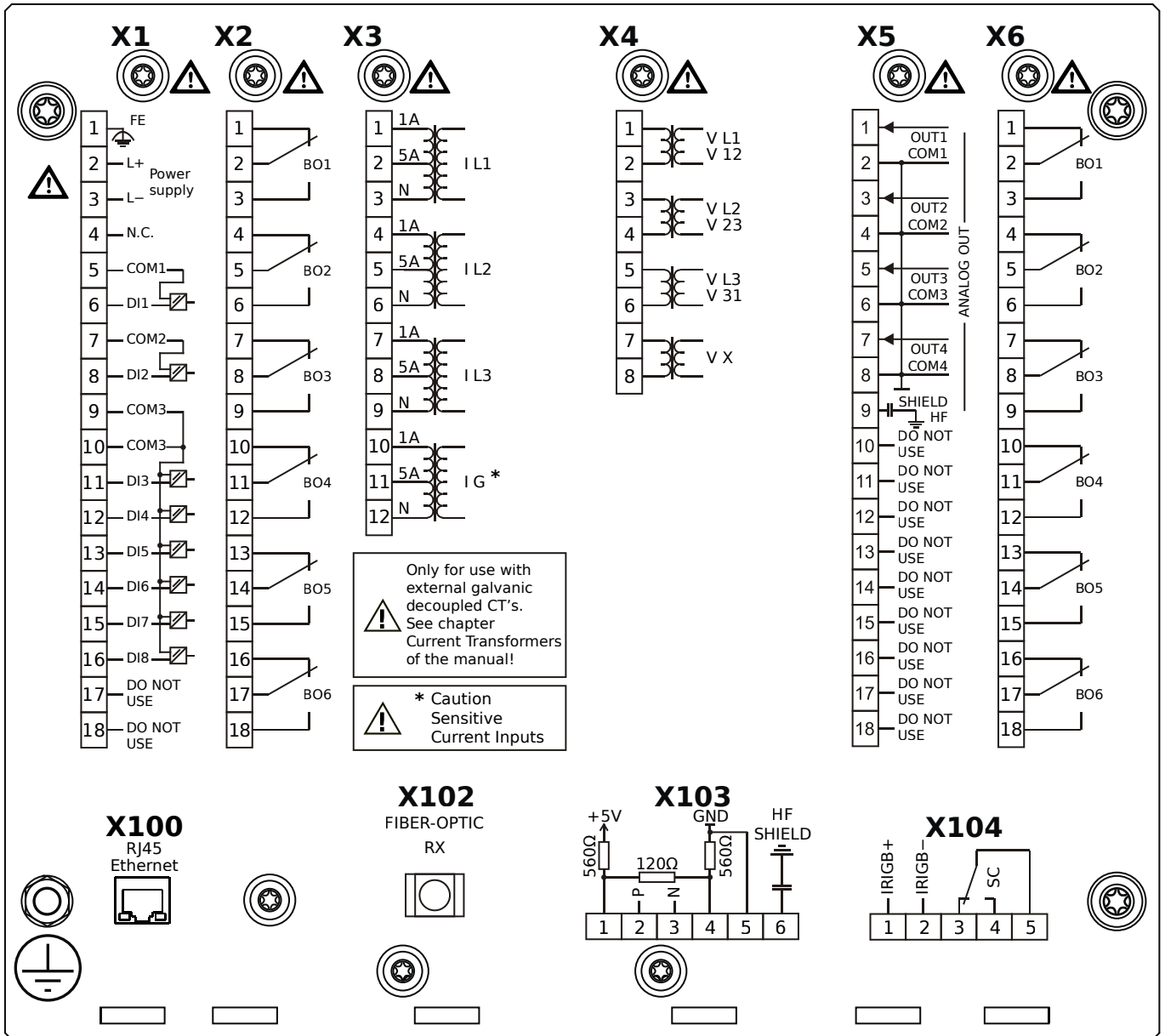

## Housing B2, small display, door mounting

- X1** – DI8-X1: Wide-range power supply unit, incl. 2 non-grouped digital inputs and 6 grouped digital inputs
- X2** – OR6: Assembly Group with 6 Output Relays (Changeover / Form C)
- X3** – TIs: Standard phase current measuring card and sensitive ground current measuring
- X4** – TU: Card with 4 voltage transformer measuring inputs (0 ... 800 VAC, under UL: 0 ... 600 VAC)
- X5** – AnO4: Analog Outputs
- X6** – OR6: Assembly Group with 6 Output Relays (Changeover / Form C)
- X100** – Modbus TCP / IEC 60870-5-104 / DNP3.0 TCP/UDP, Ethernet interface, 100 Mbit/s, RJ45 (BASE100-FX)
- X102** – Universal Resistance-Temperature Detector (URTD) input, Fiber optics interface, Versatile Link
- X103** – IEC 60870-5-103 / Modbus RTU / DNP3.0 RTU, RS485, Terminals
- X104** – IRIG-B00X, incl. System Contact (Supervision Contact)

# MRMV4-2C1AIB

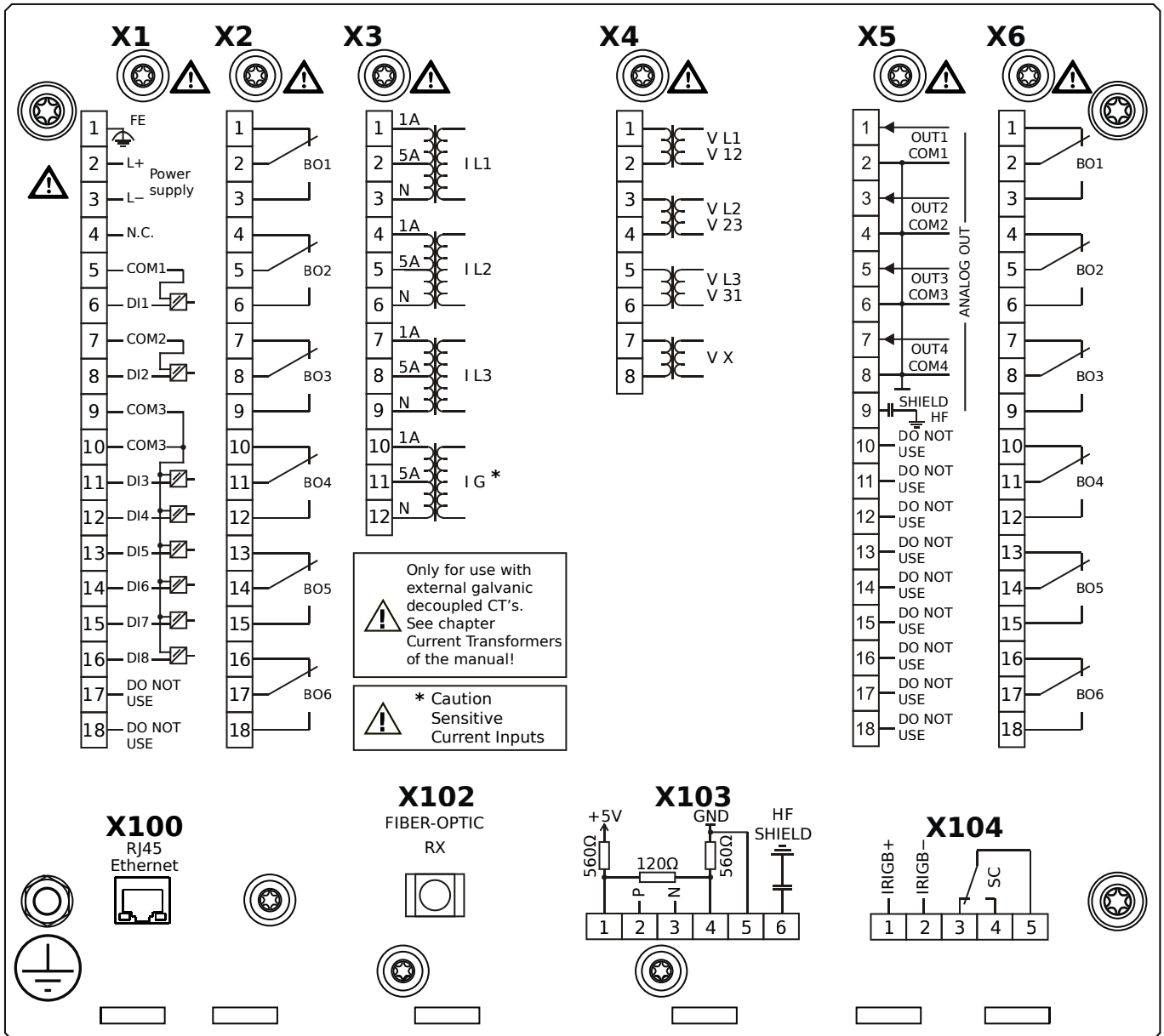

## Housing B2, small display, door mounting

+ Conformal Coating (for installations in harsh environment)

- X1** – DI8-X1: Wide-range power supply unit, incl. 2 non-grouped digital inputs and 6 grouped digital inputs
- X2** – OR6: Assembly Group with 6 Output Relays (Changeover / Form C)
- X3** – TIs: Standard phase current measuring card and sensitive ground current measuring
- X4** – TU: Card with 4 voltage transformer measuring inputs (0 ... 800 VAC, under UL: 0 ... 600 VAC)
- X5** – AnO4: Analog Outputs
- X6** – OR6: Assembly Group with 6 Output Relays (Changeover / Form C)
- X100** – Modbus TCP / IEC 60870-5-104 / DNP3.0 TCP/UDP, Ethernet interface, 100 Mbit/s, RJ45 (BASE100-FX)
- X102** – Universal Resistance-Temperature Detector (URTD) input, Fiber optics interface, Versatile Link
- X103** – IEC 60870-5-103 / Modbus RTU / DNP3.0 RTU, RS485, Terminals
- X104** – IRIG-B00X, incl. System Contact (Supervision Contact)

# MRMV4-2C1AKA

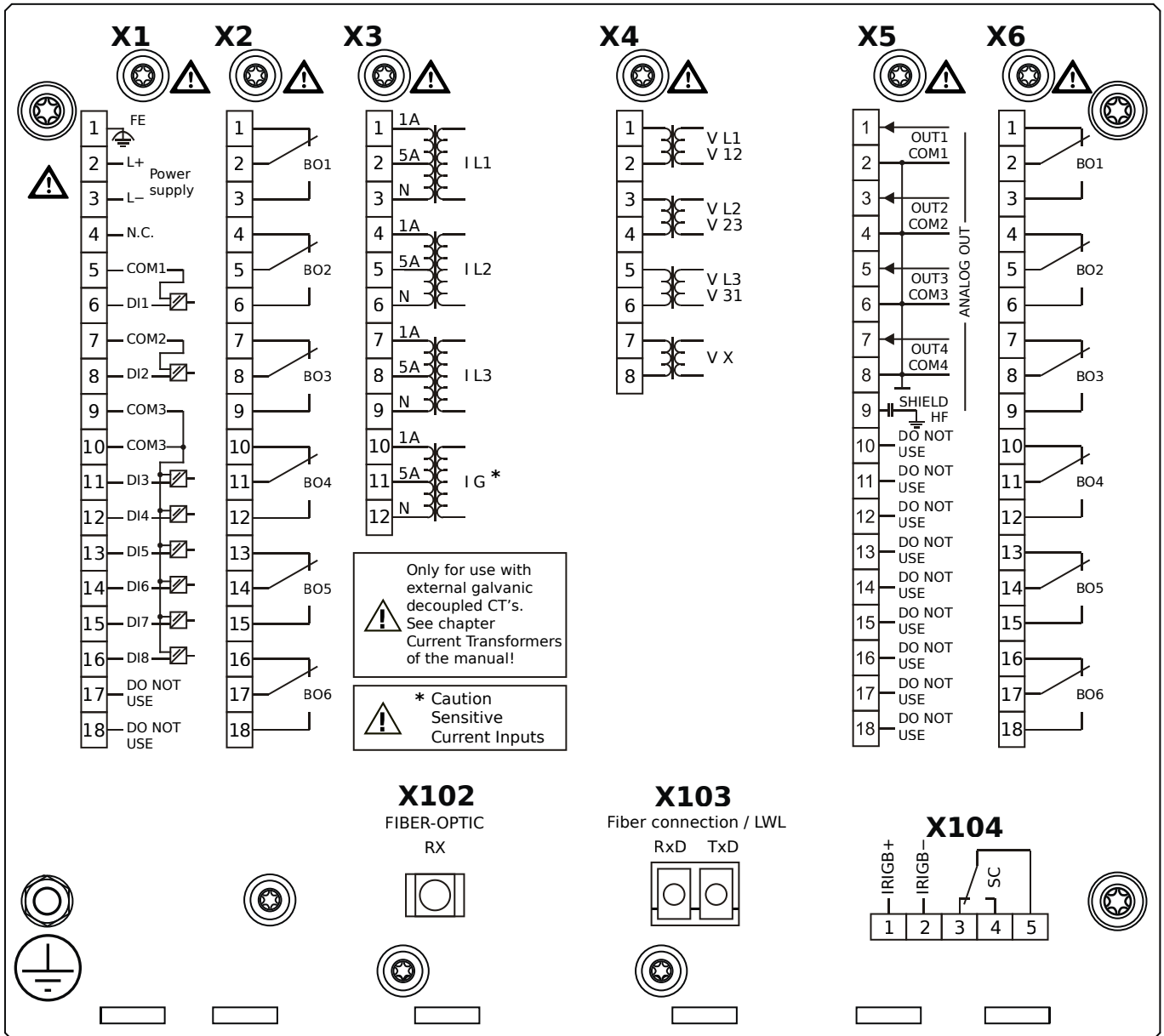

## Housing B2, small display, door mounting

- X1** – DI8-X1: Wide-range power supply unit, incl. 2 non-grouped digital inputs and 6 grouped digital inputs
- X2** – OR6: Assembly Group with 6 Output Relays (Changeover / Form C)
- X3** – TIs: Standard phase current measuring card and sensitive ground current measuring
- X4** – TU: Card with 4 voltage transformer measuring inputs (0 ... 800 VAC, under UL: 0 ... 600 VAC)
- X5** – AnO4: Analog Outputs
- X6** – OR6: Assembly Group with 6 Output Relays (Changeover / Form C)
- X102** – Universal Resistance-Temperature Detector (URTD) input, Fiber optics interface, Versatile Link
- X103** – IEC 61850 / Modbus TCP / IEC 60870-5-104 / DNP3.0 TCP/UDP, Fiber optics interface, LC Connector
- X104** – IRIG-B00X, incl. System Contact (Supervision Contact)

# MRMV4-2C1AKB

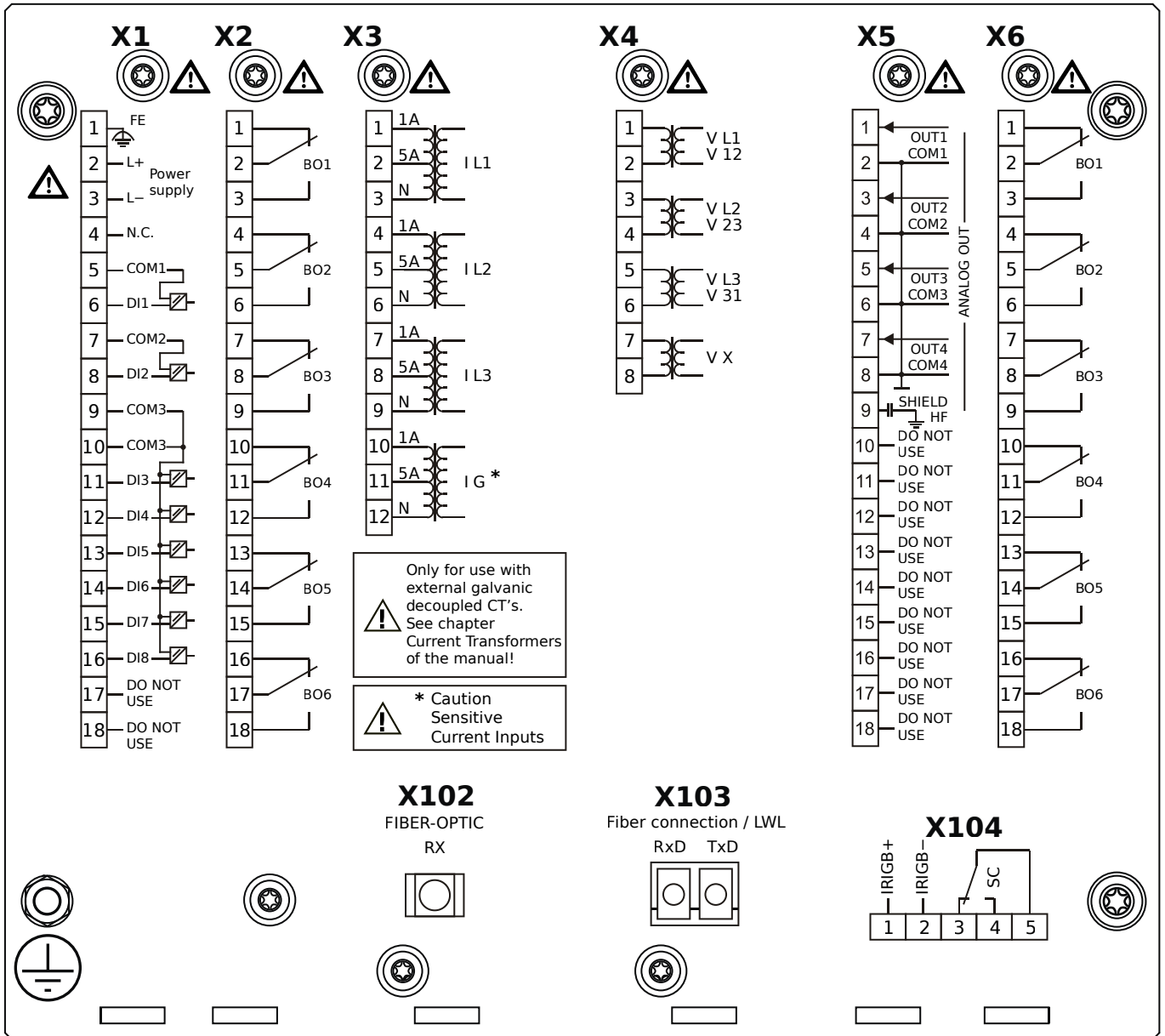

## Housing B2, small display, door mounting

+ Conformal Coating (for installations in harsh environment)

- X1** – DI8-X1: Wide-range power supply unit, incl. 2 non-grouped digital inputs and 6 grouped digital inputs
- X2** – OR6: Assembly Group with 6 Output Relays (Changeover / Form C)
- X3** – TIs: Standard phase current measuring card and sensitive ground current measuring
- X4** – TU: Card with 4 voltage transformer measuring inputs (0 ... 800 VAC, under UL: 0 ... 600 VAC)
- X5** – AnO4: Analog Outputs
- X6** – OR6: Assembly Group with 6 Output Relays (Changeover / Form C)
- X102** – Universal Resistance-Temperature Detector (URTD) input, Fiber optics interface, Versatile Link
- X103** – IEC 61850 / Modbus TCP / IEC 60870-5-104 / DNP3.0 TCP/UDP, Fiber optics interface, LC Connector
- X104** – IRIG-B00X, incl. System Contact (Supervision Contact)

# MRMV4-2C1ALA

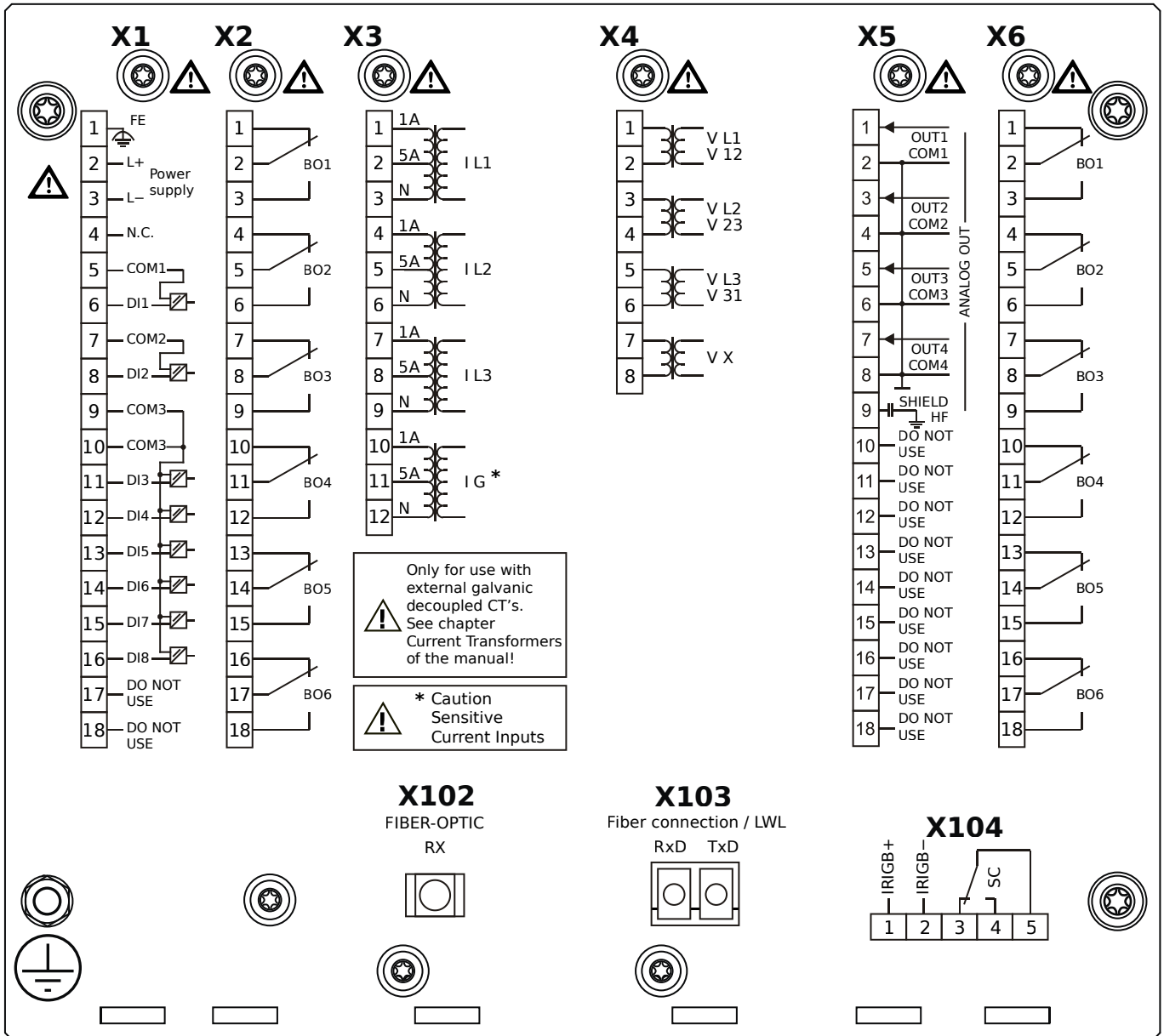

## Housing B2, small display, door mounting

- X1** – DI8-X1: Wide-range power supply unit, incl. 2 non-grouped digital inputs and 6 grouped digital inputs
- X2** – OR6: Assembly Group with 6 Output Relays (Changeover / Form C)
- X3** – TIs: Standard phase current measuring card and sensitive ground current measuring
- X4** – TU: Card with 4 voltage transformer measuring inputs (0 ... 800 VAC, under UL: 0 ... 600 VAC)
- X5** – AnO4: Analog Outputs
- X6** – OR6: Assembly Group with 6 Output Relays (Changeover / Form C)
- X102** – Universal Resistance-Temperature Detector (URTD) input, Fiber optics interface, Versatile Link
- X103** – Modbus TCP / IEC 60870-5-104 / DNP3.0 TCP/UDP, Fiber optics interface, LC Connector
- X104** – IRIG-B00X, incl. System Contact (Supervision Contact)

# MRMV4-2C1ALB

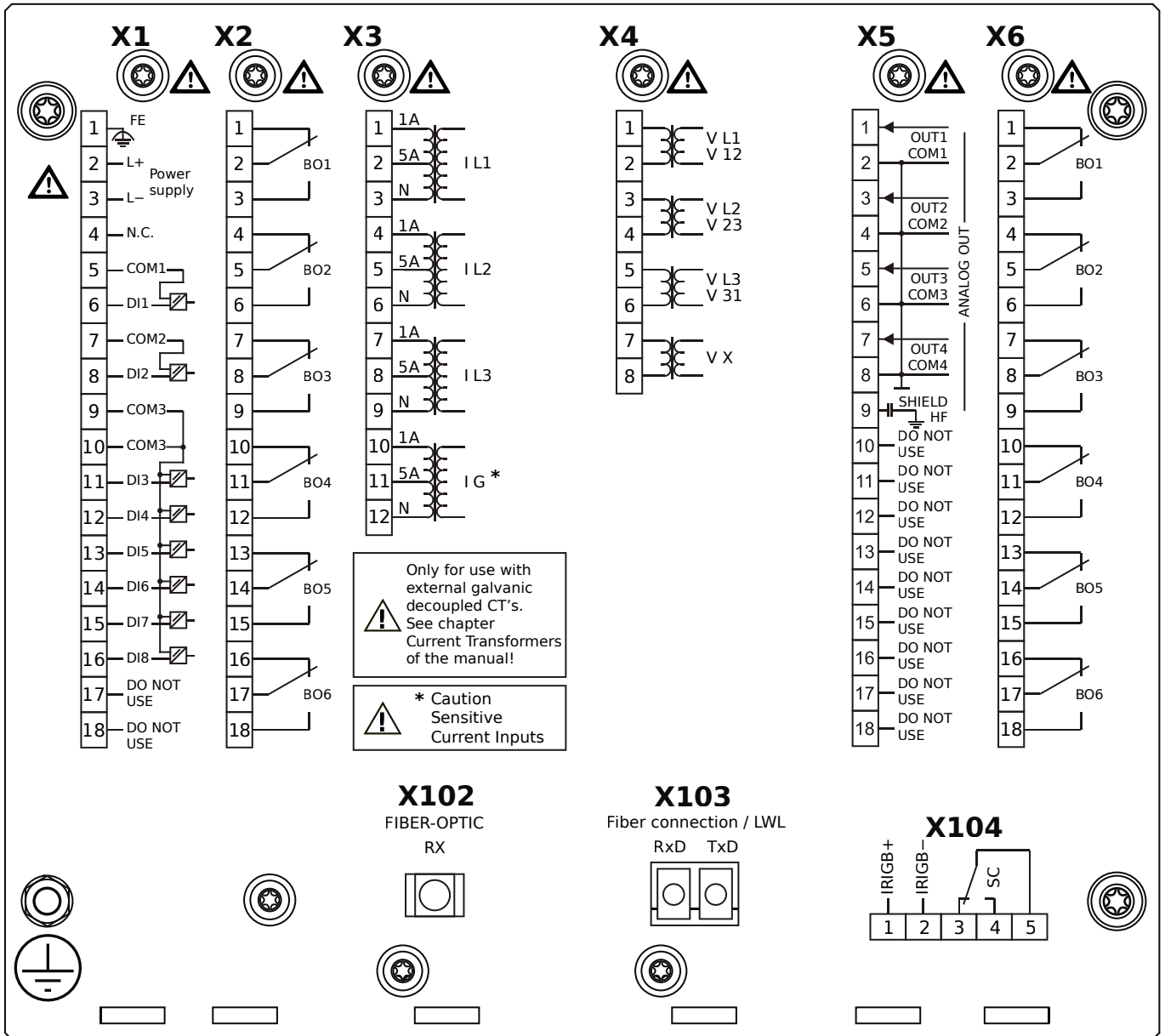

## Housing B2, small display, door mounting

+ Conformal Coating (for installations in harsh environment)

- X1** – DI8-X1: Wide-range power supply unit, incl. 2 non-grouped digital inputs and 6 grouped digital inputs
- X2** – OR6: Assembly Group with 6 Output Relays (Changeover / Form C)
- X3** – TIs: Standard phase current measuring card and sensitive ground current measuring
- X4** – TU: Card with 4 voltage transformer measuring inputs (0 ... 800 VAC, under UL: 0 ... 600 VAC)
- X5** – AnO4: Analog Outputs
- X6** – OR6: Assembly Group with 6 Output Relays (Changeover / Form C)
- X102** – Universal Resistance-Temperature Detector (URTD) input, Fiber optics interface, Versatile Link
- X103** – Modbus TCP / IEC 60870-5-104 / DNP3.0 TCP/UDP, Fiber optics interface, LC Connector
- X104** – IRIG-B00X, incl. System Contact (Supervision Contact)

# MRMV4-2C1AOA

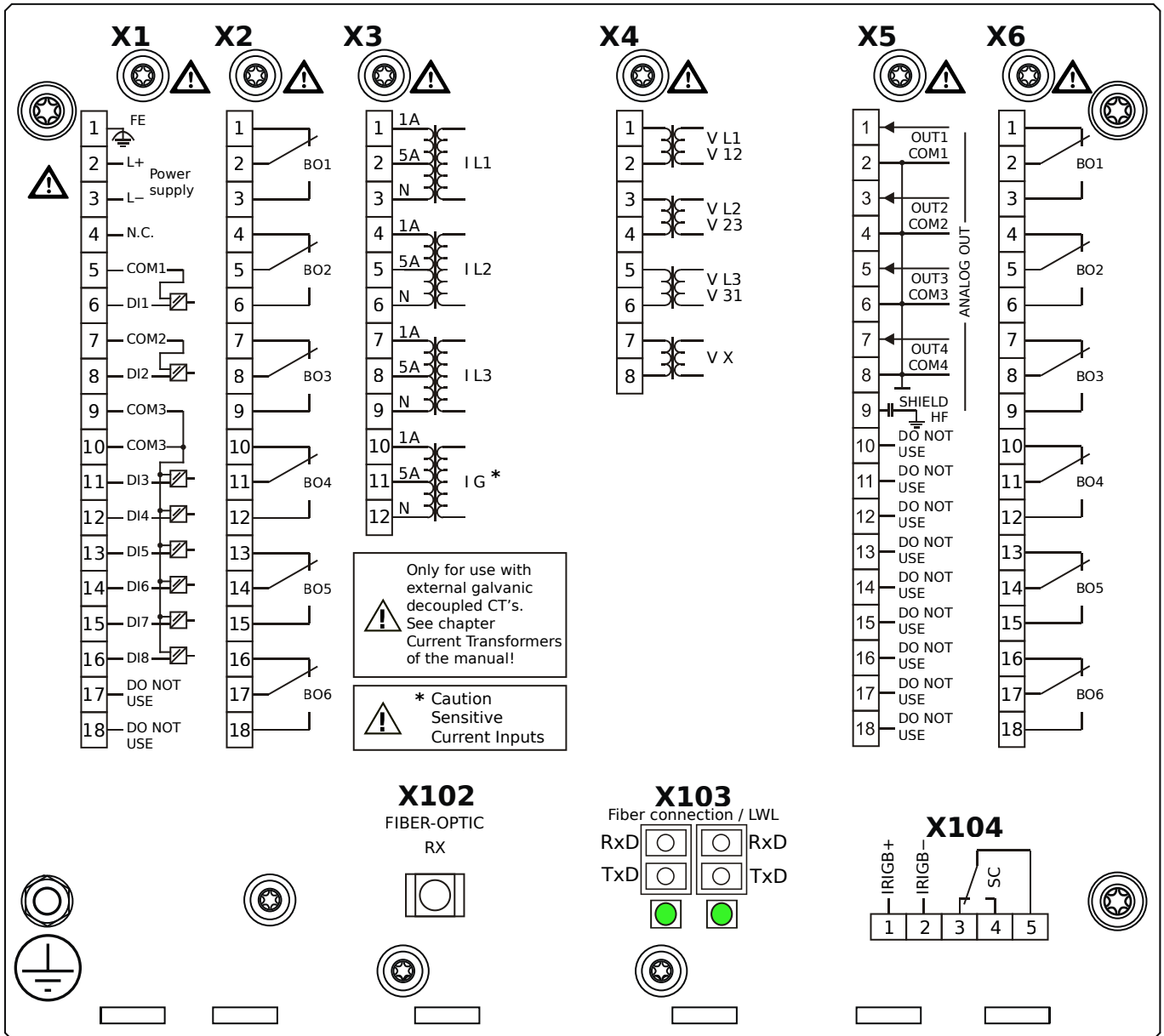

## Housing B2, small display, door mounting

- X1** – DI8-X1: Wide-range power supply unit, incl. 2 non-grouped digital inputs and 6 grouped digital inputs
- X2** – OR6: Assembly Group with 6 Output Relays (Changeover / Form C)
- X3** – TIs: Standard phase current measuring card and sensitive ground current measuring
- X4** – TU: Card with 4 voltage transformer measuring inputs (0 ... 800 VAC, under UL: 0 ... 600 VAC)
- X5** – AnO4: Analog Outputs
- X6** – OR6: Assembly Group with 6 Output Relays (Changeover / Form C)
- X102** – Universal Resistance-Temperature Detector (URTD) input, Fiber optics interface, Versatile Link
- X103** – Modbus TCP / IEC 60870-5-104 / DNP3.0 TCP/UDP, Redundant Fiber optics interface, LC Connector
- X104** – IRIG-B00X, incl. System Contact (Supervision Contact)



# MRMV4-2C1AOB

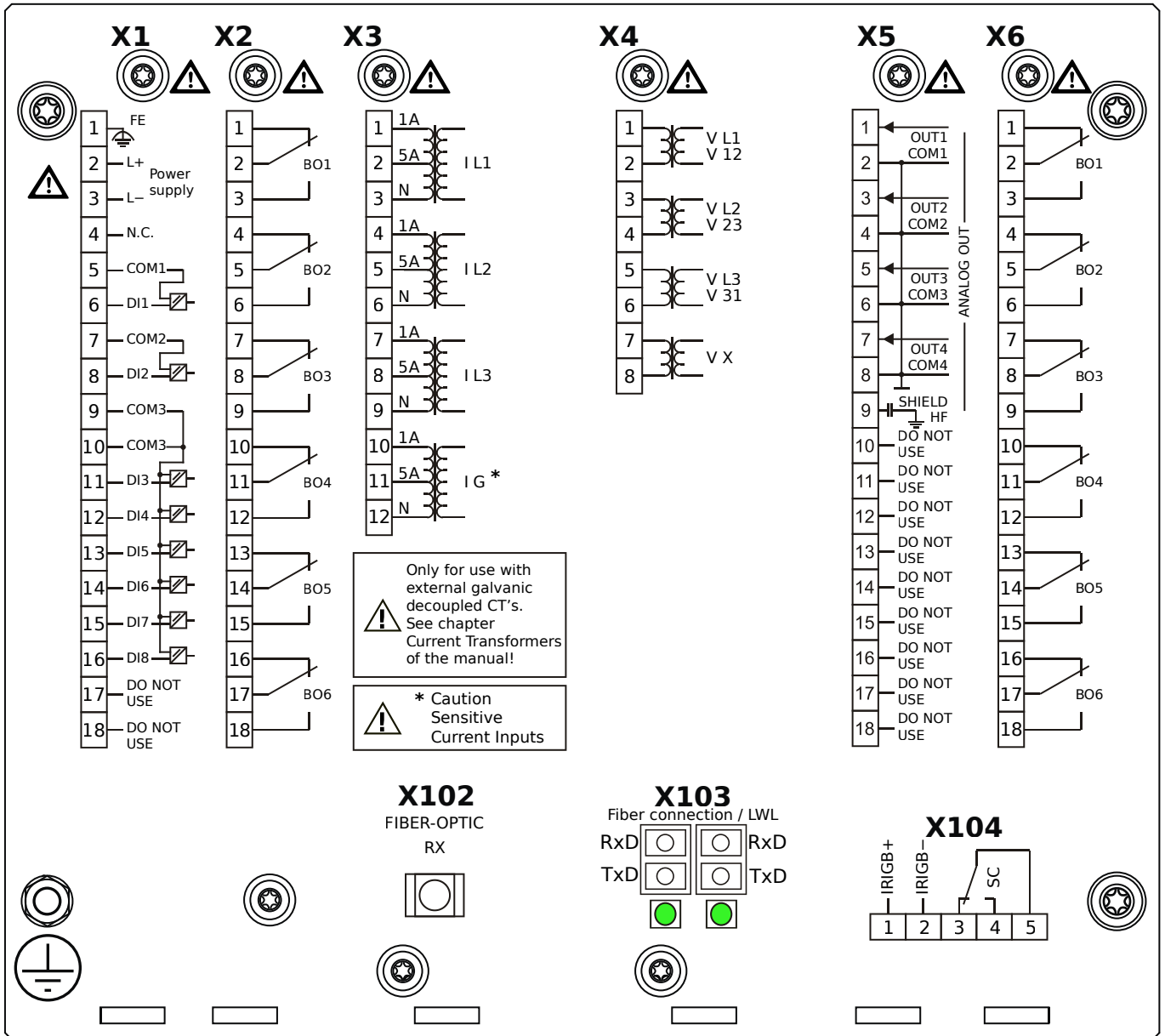

## Housing B2, small display, door mounting

+ Conformal Coating (for installations in harsh environment)

- X1** – DI8-X1: Wide-range power supply unit, incl. 2 non-grouped digital inputs and 6 grouped digital inputs
- X2** – OR6: Assembly Group with 6 Output Relays (Changeover / Form C)
- X3** – TIs: Standard phase current measuring card and sensitive ground current measuring
- X4** – TU: Card with 4 voltage transformer measuring inputs (0 ... 800 VAC, under UL: 0 ... 600 VAC)
- X5** – AnO4: Analog Outputs
- X6** – OR6: Assembly Group with 6 Output Relays (Changeover / Form C)
- X102** – Universal Resistance-Temperature Detector (URTD) input, Fiber optics interface, Versatile Link
- X103** – Modbus TCP / IEC 60870-5-104 / DNP3.0 TCP/UDP, Redundant Fiber optics interface, LC Connector
- X104** – IRIG-B00X, incl. System Contact (Supervision Contact)

# MRMV4-2C1APA

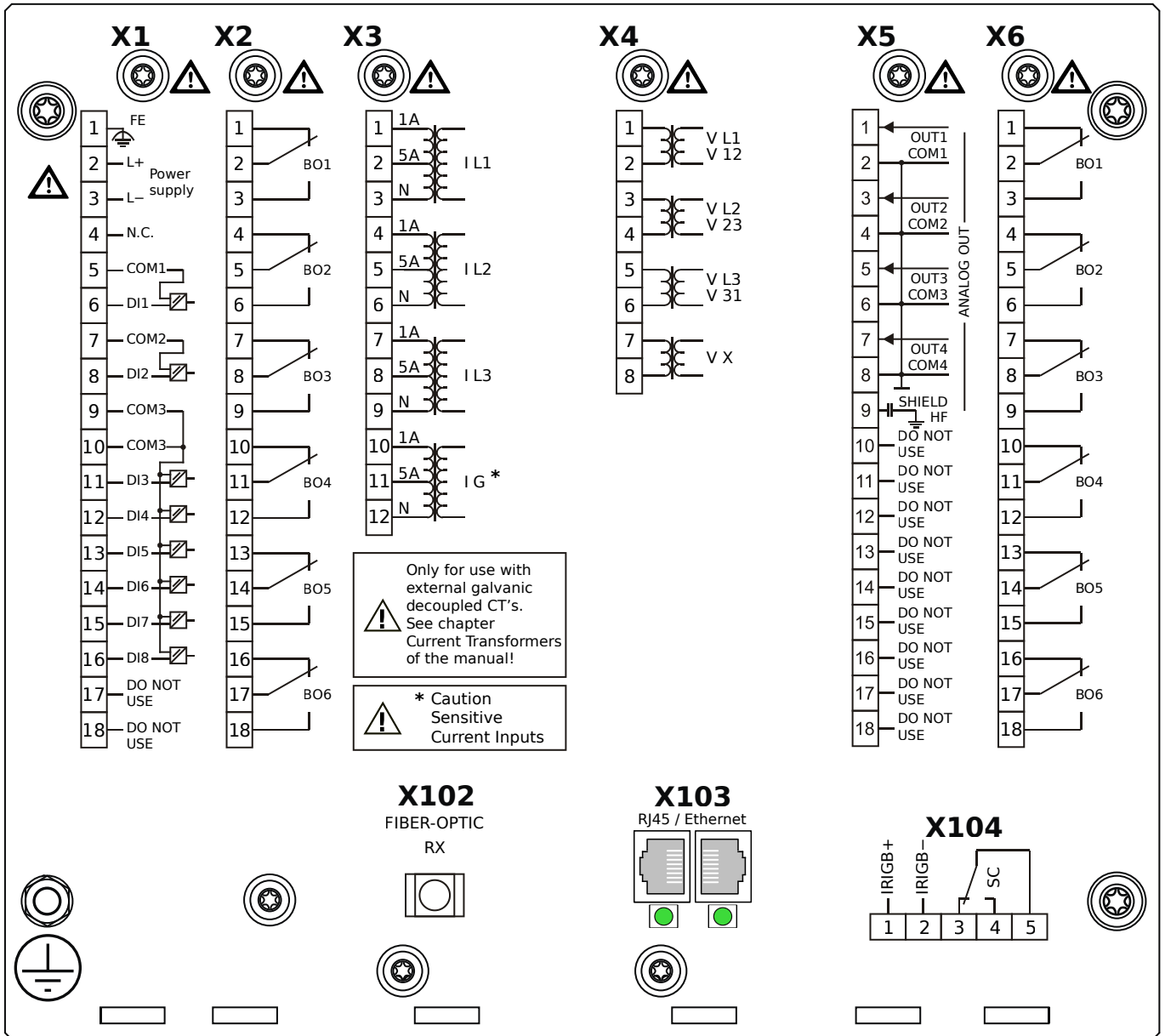

## Housing B2, small display, door mounting

- X1** – DI8-X1: Wide-range power supply unit, incl. 2 non-grouped digital inputs and 6 grouped digital inputs
- X2** – OR6: Assembly Group with 6 Output Relays (Changeover / Form C)
- X3** – TIs: Standard phase current measuring card and sensitive ground current measuring
- X4** – TU: Card with 4 voltage transformer measuring inputs (0 ... 800 VAC, under UL: 0 ... 600 VAC)
- X5** – AnO4: Analog Outputs
- X6** – OR6: Assembly Group with 6 Output Relays (Changeover / Form C)
- X102** – Universal Resistance-Temperature Detector (URTD) input, Fiber optics interface, Versatile Link
- X103** – Modbus TCP / IEC 60870-5-104 / DNP3.0 TCP/UDP, Redundant Ethernet interface, 100 Mbit/s, RJ45 (BASE100-FX)
- X104** – IRIG-B00X, incl. System Contact (Supervision Contact)

# MRMV4-2C1APB

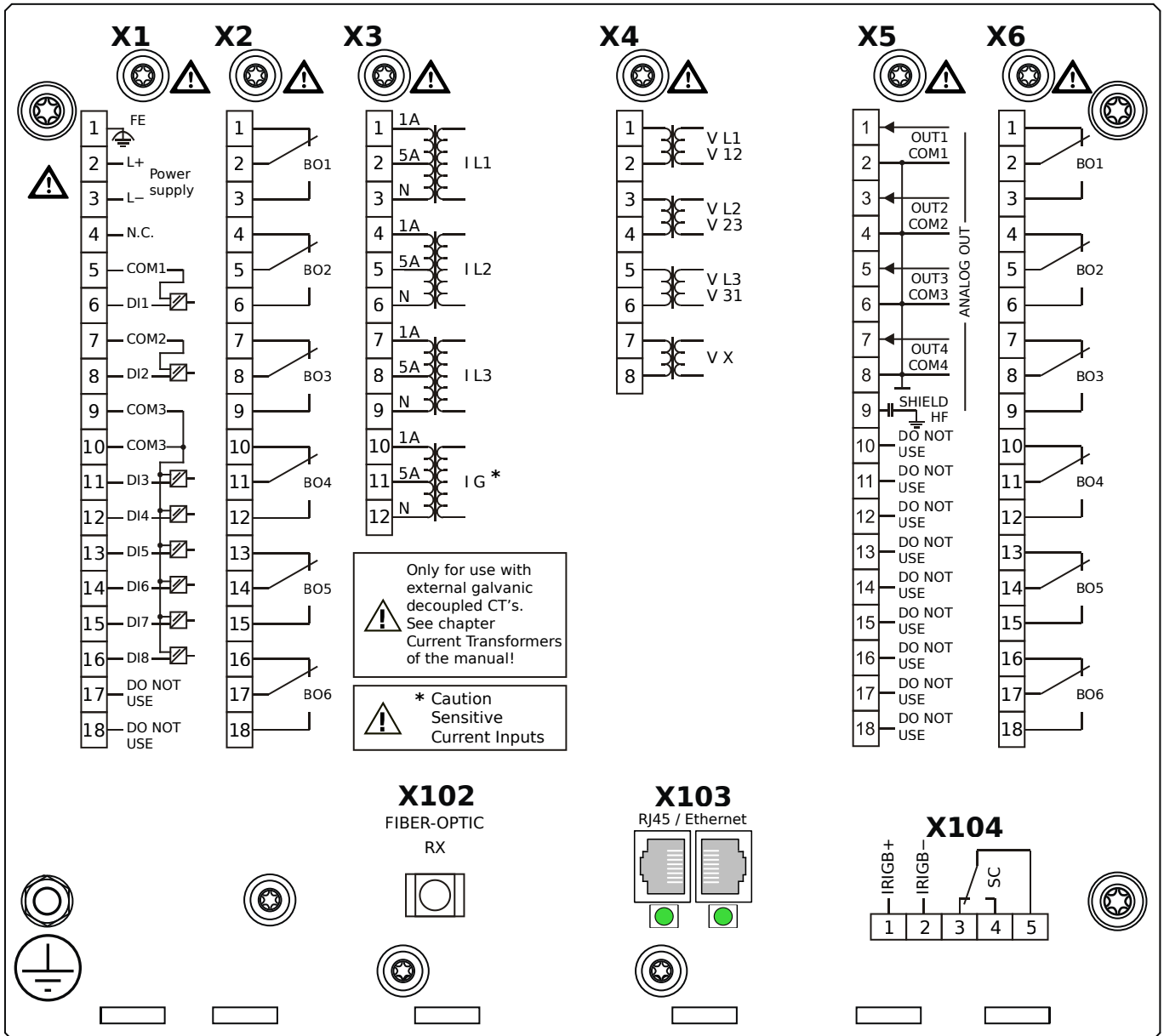

## Housing B2, small display, door mounting

+ Conformal Coating (for installations in harsh environment)

- X1** – DI8-X1: Wide-range power supply unit, incl. 2 non-grouped digital inputs and 6 grouped digital inputs
- X2** – OR6: Assembly Group with 6 Output Relays (Changeover / Form C)
- X3** – TIs: Standard phase current measuring card and sensitive ground current measuring
- X4** – TU: Card with 4 voltage transformer measuring inputs (0 ... 800 VAC, under UL: 0 ... 600 VAC)
- X5** – AnO4: Analog Outputs
- X6** – OR6: Assembly Group with 6 Output Relays (Changeover / Form C)
- X102** – Universal Resistance-Temperature Detector (URTD) input, Fiber optics interface, Versatile Link
- X103** – Modbus TCP / IEC 60870-5-104 / DNP3.0 TCP/UDP, Redundant Ethernet interface, 100 Mbit/s, RJ45 (BASE100-FX)
- X104** – IRIG-B00X, incl. System Contact (Supervision Contact)

# MRMV4-2C1AQA

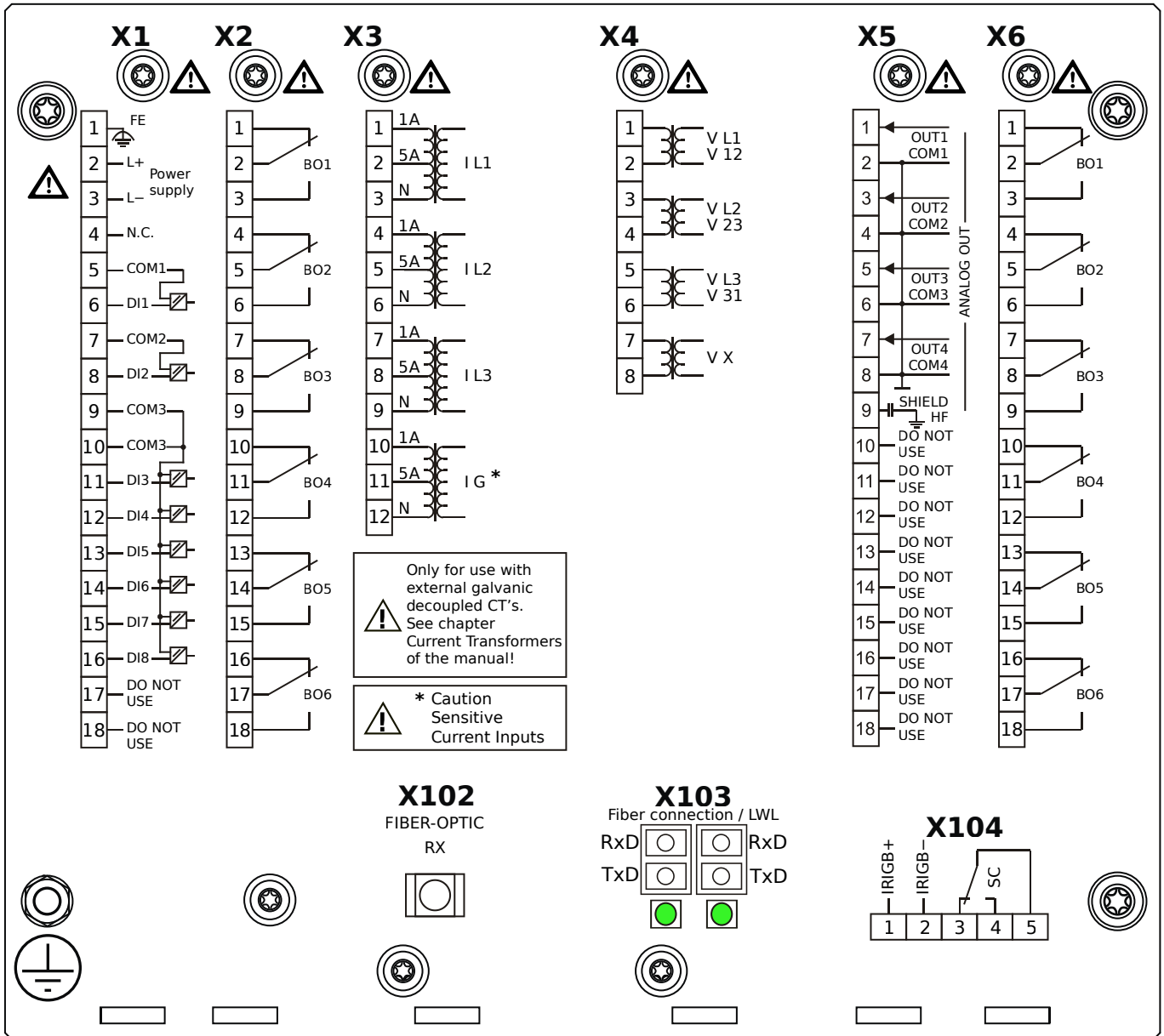

## Housing B2, small display, door mounting

- X1** – DI8-X1: Wide-range power supply unit, incl. 2 non-grouped digital inputs and 6 grouped digital inputs
- X2** – OR6: Assembly Group with 6 Output Relays (Changeover / Form C)
- X3** – TIs: Standard phase current measuring card and sensitive ground current measuring
- X4** – TU: Card with 4 voltage transformer measuring inputs (0 ... 800 VAC, under UL: 0 ... 600 VAC)
- X5** – AnO4: Analog Outputs
- X6** – OR6: Assembly Group with 6 Output Relays (Changeover / Form C)
- X102** – Universal Resistance-Temperature Detector (URTD) input, Fiber optics interface, Versatile Link
- X103** – IEC 61850 / Modbus TCP / IEC 60870-5-104 / DNP3.0 TCP/UDP, Redundant Fiber optics interface, LC Connector
- X104** – IRIG-B00X, incl. System Contact (Supervision Contact)

# MRMV4-2C1AQB

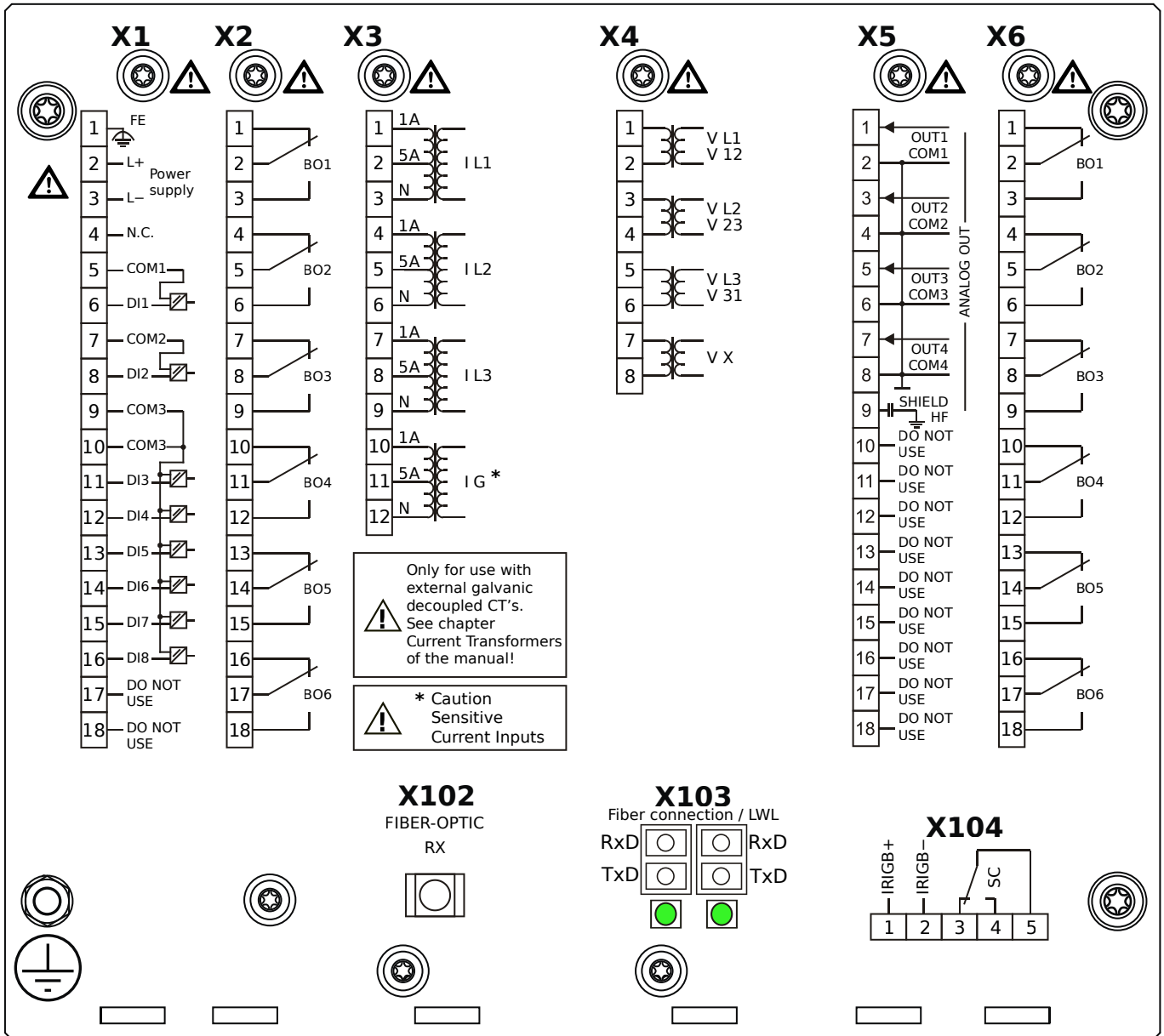

## Housing B2, small display, door mounting

+ Conformal Coating (for installations in harsh environment)

- X1** – DI8-X1: Wide-range power supply unit, incl. 2 non-grouped digital inputs and 6 grouped digital inputs
- X2** – OR6: Assembly Group with 6 Output Relays (Changeover / Form C)
- X3** – TIs: Standard phase current measuring card and sensitive ground current measuring
- X4** – TU: Card with 4 voltage transformer measuring inputs (0 ... 800 VAC, under UL: 0 ... 600 VAC)
- X5** – AnO4: Analog Outputs
- X6** – OR6: Assembly Group with 6 Output Relays (Changeover / Form C)
- X102** – Universal Resistance-Temperature Detector (URTD) input, Fiber optics interface, Versatile Link
- X103** – IEC 61850 / Modbus TCP / IEC 60870-5-104 / DNP3.0 TCP/UDP, Redundant Fiber optics interface, LC Connector
- X104** – IRIG-B00X, incl. System Contact (Supervision Contact)

# MRMV4-2C1ARA

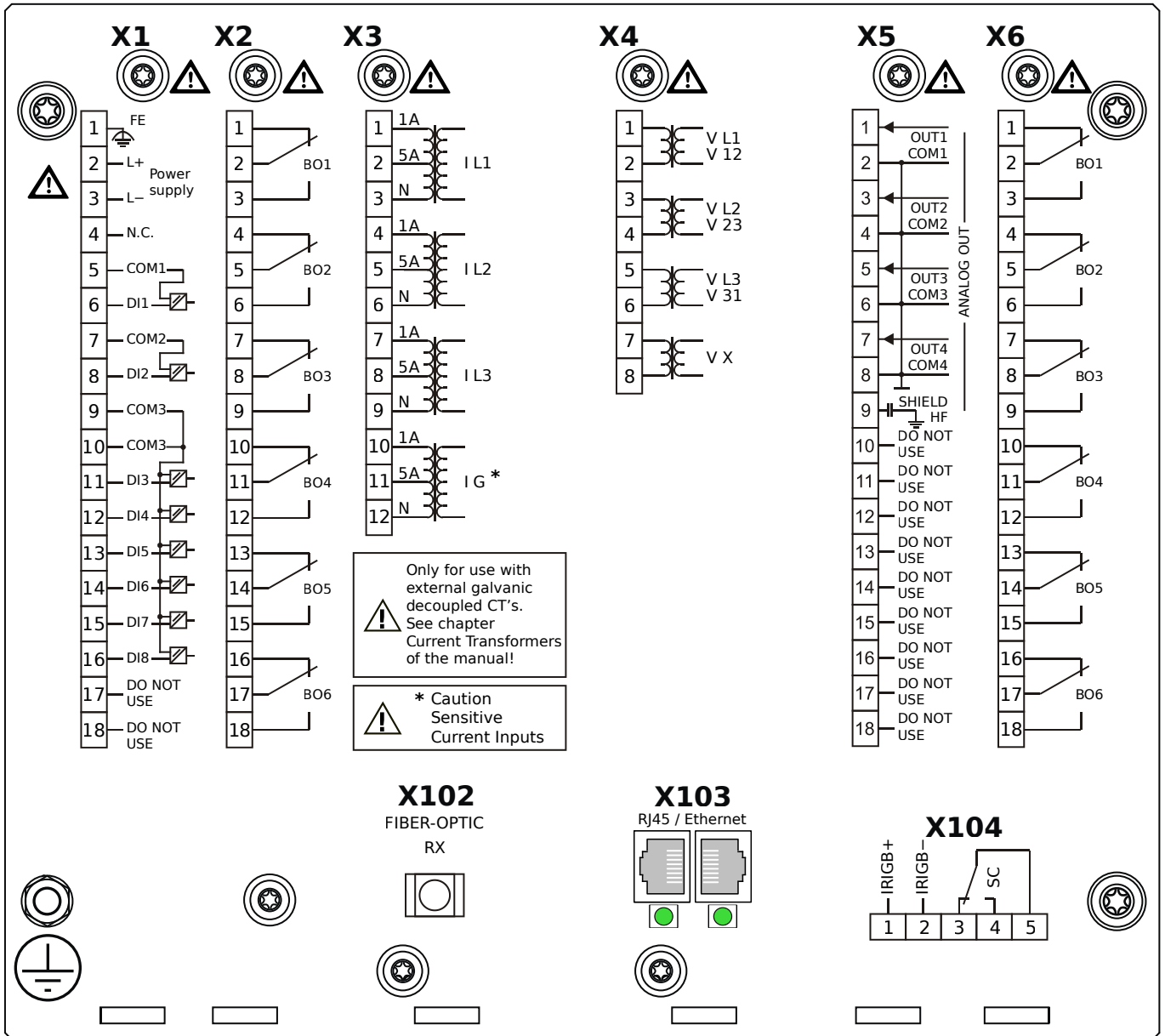

## Housing B2, small display, door mounting

- X1** – DI8-X1: Wide-range power supply unit, incl. 2 non-grouped digital inputs and 6 grouped digital inputs
- X2** – OR6: Assembly Group with 6 Output Relays (Changeover / Form C)
- X3** – TIs: Standard phase current measuring card and sensitive ground current measuring
- X4** – TU: Card with 4 voltage transformer measuring inputs (0 ... 800 VAC, under UL: 0 ... 600 VAC)
- X5** – AnO4: Analog Outputs
- X6** – OR6: Assembly Group with 6 Output Relays (Changeover / Form C)
- X102** – Universal Resistance-Temperature Detector (URTD) input, Fiber optics interface, Versatile Link
- X103** – IEC 61850 / Modbus TCP / IEC 60870-5-104 / DNP3.0 TCP/UDP, Redundant Ethernet interface, 100 Mbit/s, RJ45
- X104** – IRIG-B00X, incl. System Contact (Supervision Contact)

# MRMV4-2C1ARB

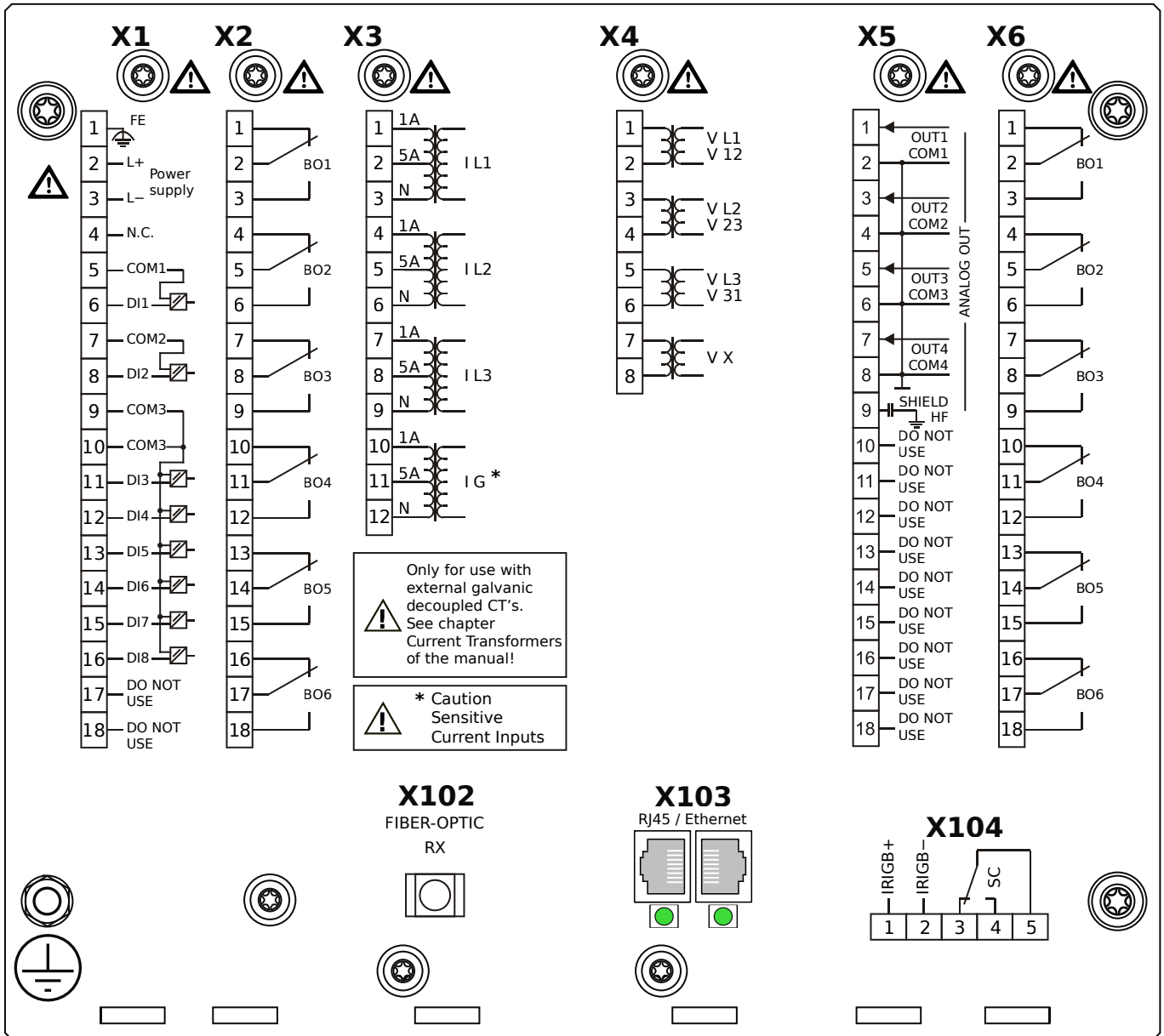

## Housing B2, small display, door mounting

+ Conformal Coating (for installations in harsh environment)

**X1** – DI8-X1: Wide-range power supply unit, incl. 2 non-grouped digital inputs and 6 grouped digital inputs

**X2** – OR6: Assembly Group with 6 Output Relays (Changeover / Form C)

**X3** – TIs: Standard phase current measuring card and sensitive ground current measuring

**X4** – TU: Card with 4 voltage transformer measuring inputs (0 ... 800 VAC, under UL: 0 ... 600 VAC)

**X5** – AnO4: Analog Outputs

**X6** – OR6: Assembly Group with 6 Output Relays (Changeover / Form C)

**X102** – Universal Resistance-Temperature Detector (URTD) input, Fiber optics interface, Versatile Link

**X103** – IEC 61850 / Modbus TCP / IEC 60870-5-104 / DNP3.0 TCP/UDP, Redundant Ethernet interface, 100 Mbit/s, RJ45

(BASE100-FX)

**X104** – IRIG-B00X, incl. System Contact (Supervision Contact)

# MRMV4-2C1ATA

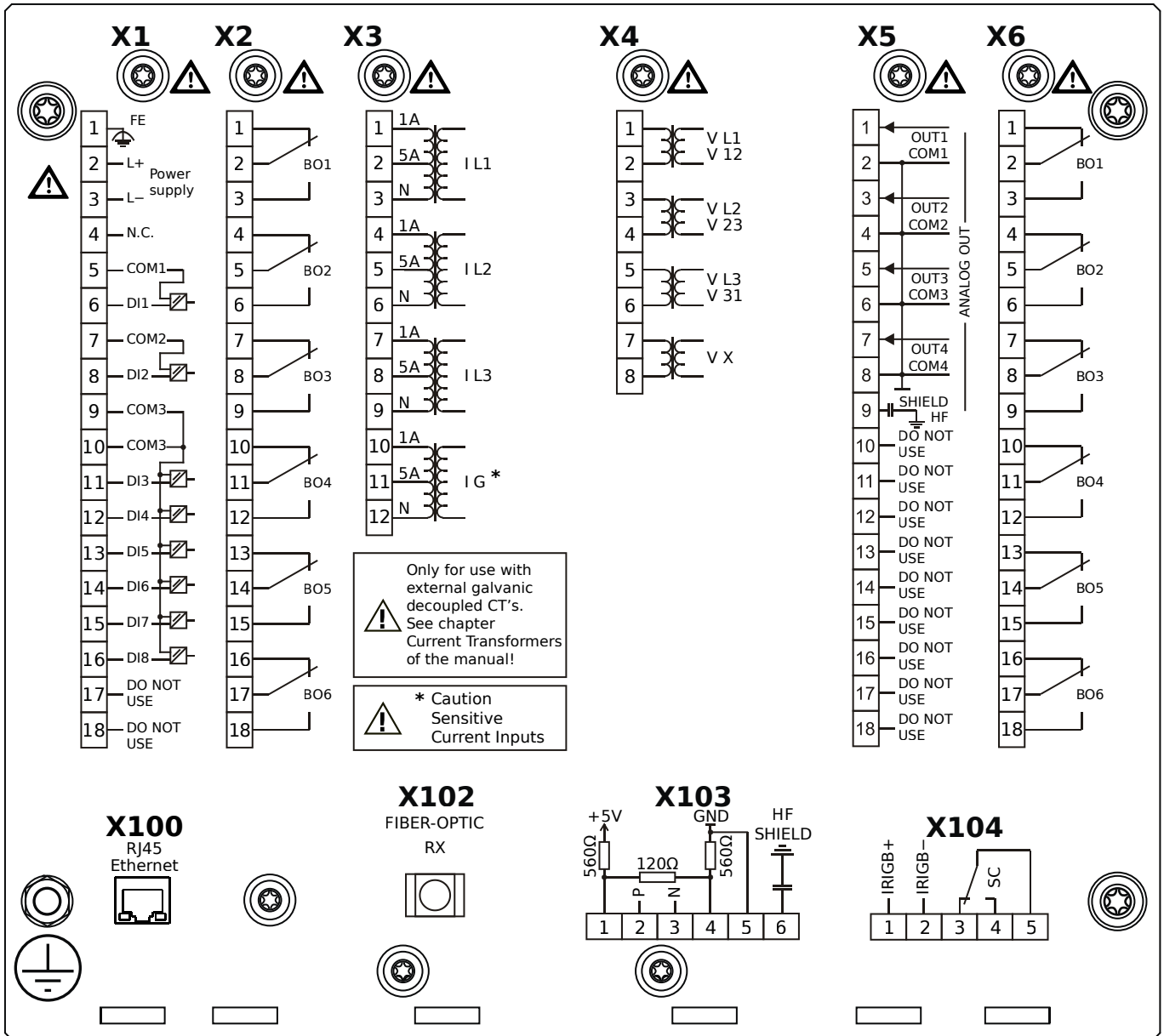

## Housing B2, small display, door mounting

- X1** – DI8-X1: Wide-range power supply unit, incl. 2 non-grouped digital inputs and 6 grouped digital inputs
- X2** – OR6: Assembly Group with 6 Output Relays (Changeover / Form C)
- X3** – TIs: Standard phase current measuring card and sensitive ground current measuring
- X4** – TU: Card with 4 voltage transformer measuring inputs (0 ... 800 VAC, under UL: 0 ... 600 VAC)
- X5** – AnO4: Analog Outputs
- X6** – OR6: Assembly Group with 6 Output Relays (Changeover / Form C)
- X100** – IEC 61850 / Modbus TCP / IEC 60870-5-104 / DNP3.0 TCP/UDP, Ethernet interface, 100 Mbit/s, RJ45 (BASE100-FX)
- X102** – Universal Resistance-Temperature Detector (URTD) input, Fiber optics interface, Versatile Link
- X103** – IEC 60870-5-103 / Modbus RTU / DNP3.0 RTU, RS485, Terminals
- X104** – IRIG-B00X, incl. System Contact (Supervision Contact)



# MRMV4-2C1ATB

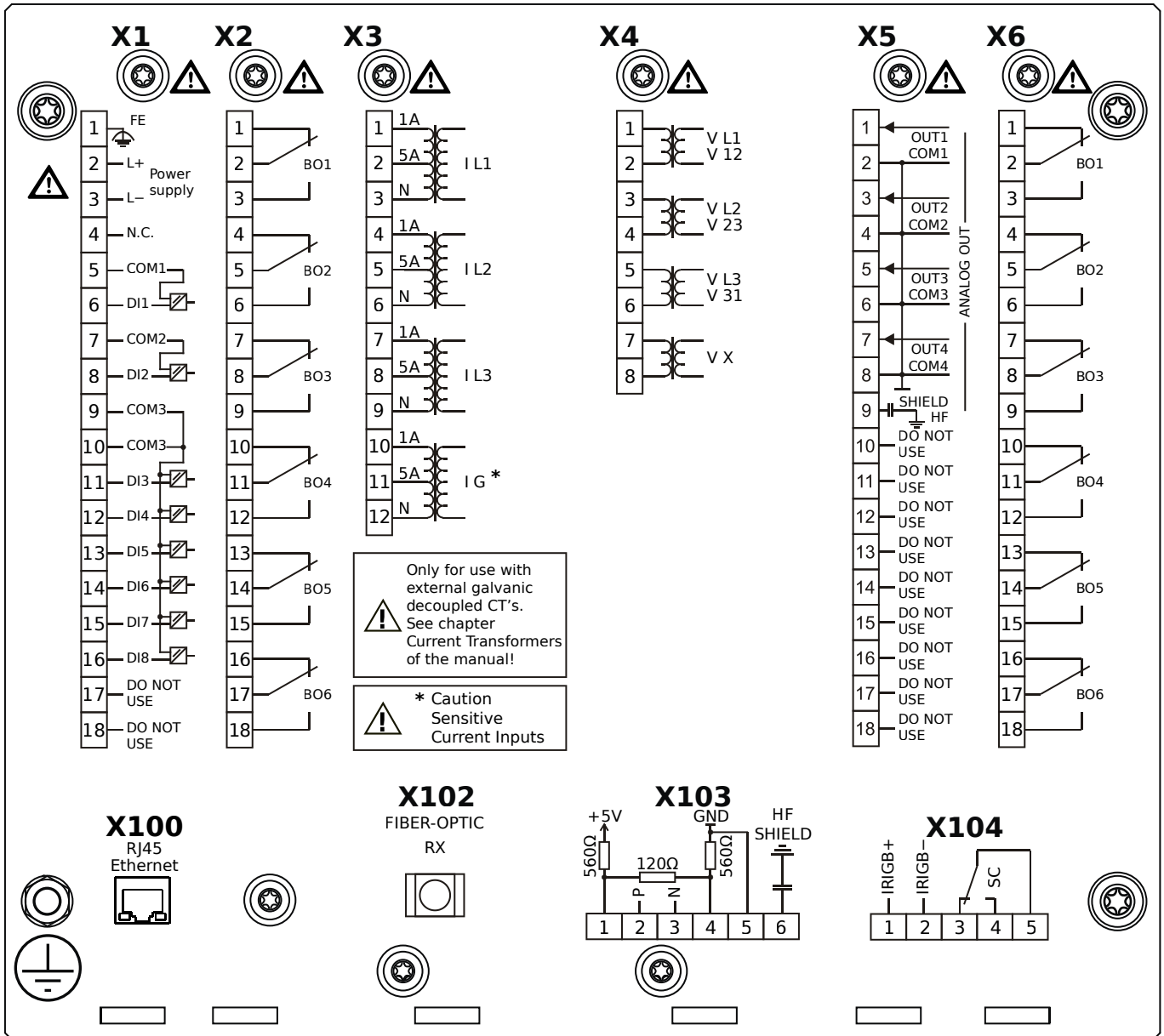

## Housing B2, small display, door mounting

+ Conformal Coating (for installations in harsh environment)

- X1** – DI8-X1: Wide-range power supply unit, incl. 2 non-grouped digital inputs and 6 grouped digital inputs
- X2** – OR6: Assembly Group with 6 Output Relays (Changeover / Form C)
- X3** – TIs: Standard phase current measuring card and sensitive ground current measuring
- X4** – TU: Card with 4 voltage transformer measuring inputs (0 ... 800 VAC, under UL: 0 ... 600 VAC)
- X5** – AnO4: Analog Outputs
- X6** – OR6: Assembly Group with 6 Output Relays (Changeover / Form C)
- X100** – IEC 61850 / Modbus TCP / IEC 60870-5-104 / DNP3.0 TCP/UDP, Ethernet interface, 100 Mbit/s, RJ45 (BASE100-FX)
- X102** – Universal Resistance-Temperature Detector (URTD) input, Fiber optics interface, Versatile Link
- X103** – IEC 60870-5-103 / Modbus RTU / DNP3.0 RTU, RS485, Terminals
- X104** – IRIG-B00X, incl. System Contact (Supervision Contact)

# MRMV4-2C1BAA

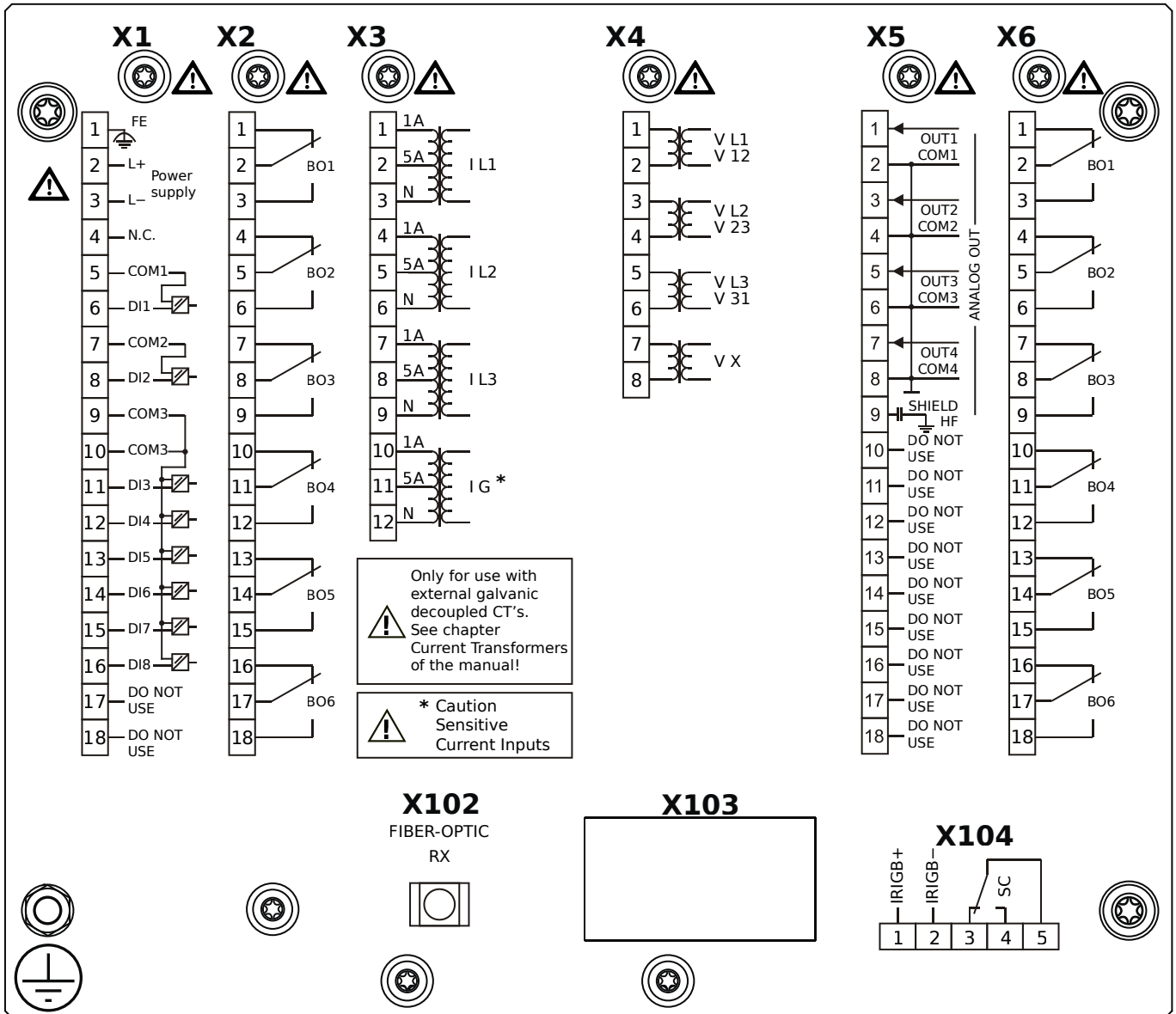

## Housing B2, small display, 19" rack mounting

- X1** – DI8-X1: Wide-range power supply unit, incl. 2 non-grouped digital inputs and 6 grouped digital inputs
- X2** – OR6: Assembly Group with 6 Output Relays (Changeover / Form C)
- X3** – TIs: Standard phase current measuring card and sensitive ground current measuring
- X4** – TU: Card with 4 voltage transformer measuring inputs (0 ... 800 VAC, under UL: 0 ... 600 VAC)
- X5** – AnO4: Analog Outputs
- X6** – OR6: Assembly Group with 6 Output Relays (Changeover / Form C)
- X102** – Universal Resistance-Temperature Detector (URTD) input, Fiber optics interface, Versatile Link
- X104** – IRIG-B00X, incl. System Contact (Supervision Contact)

# MRMV4-2C1BAB

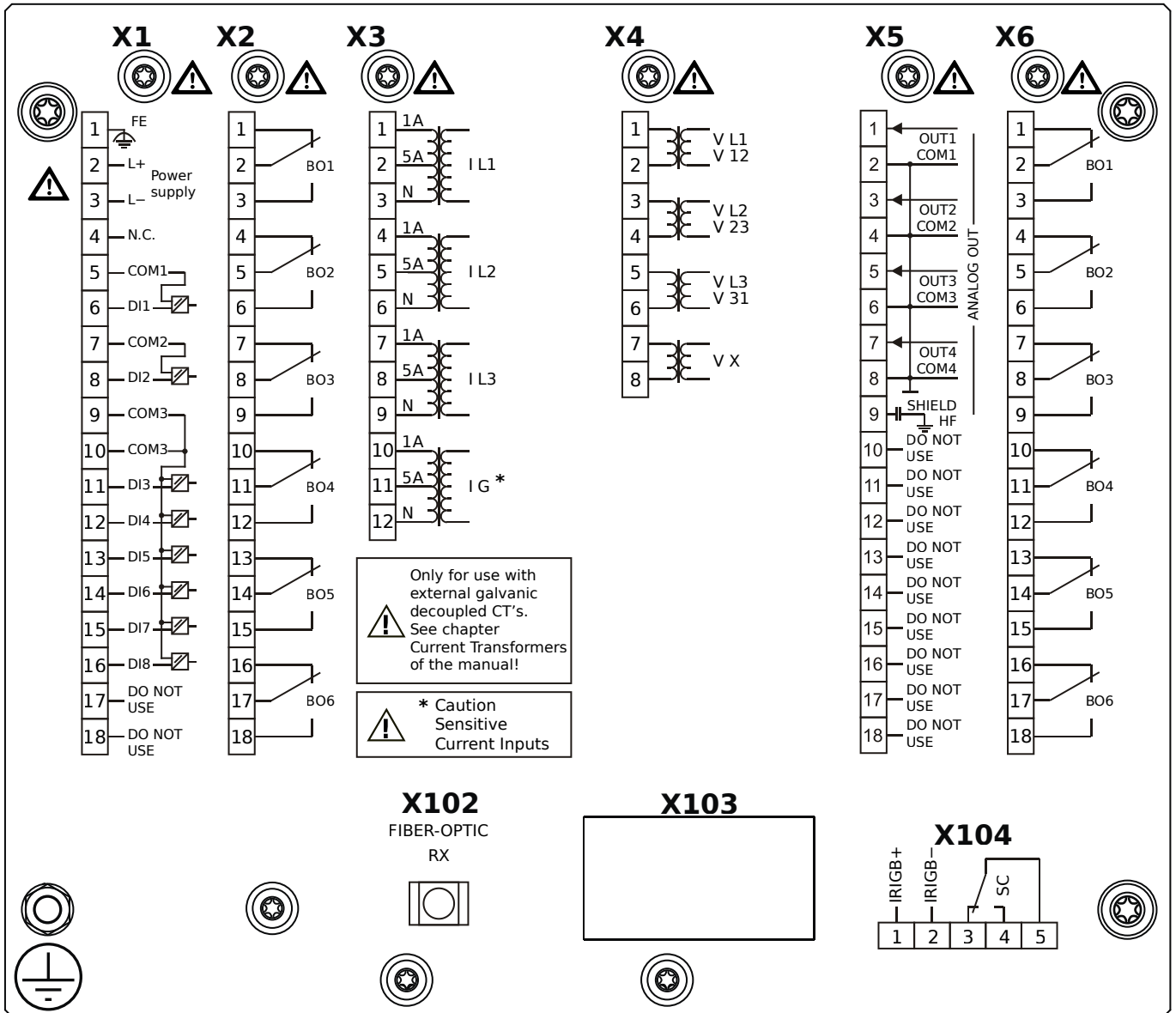

## Housing B2, small display, 19" rack mounting

+ Conformal Coating (for installations in harsh environment)

- X1** – DI8-X1: Wide-range power supply unit, incl. 2 non-grouped digital inputs and 6 grouped digital inputs
- X2** – OR6: Assembly Group with 6 Output Relays (Changeover / Form C)
- X3** – TIs: Standard phase current measuring card and sensitive ground current measuring
- X4** – TU: Card with 4 voltage transformer measuring inputs (0 ... 800 VAC, under UL: 0 ... 600 VAC)
- X5** – AnO4: Analog Outputs
- X6** – OR6: Assembly Group with 6 Output Relays (Changeover / Form C)
- X102** – Universal Resistance-Temperature Detector (URTD) input, Fiber optics interface, Versatile Link
- X104** – IRIG-B00X, incl. System Contact (Supervision Contact)

# MRMV4-2C1BBA

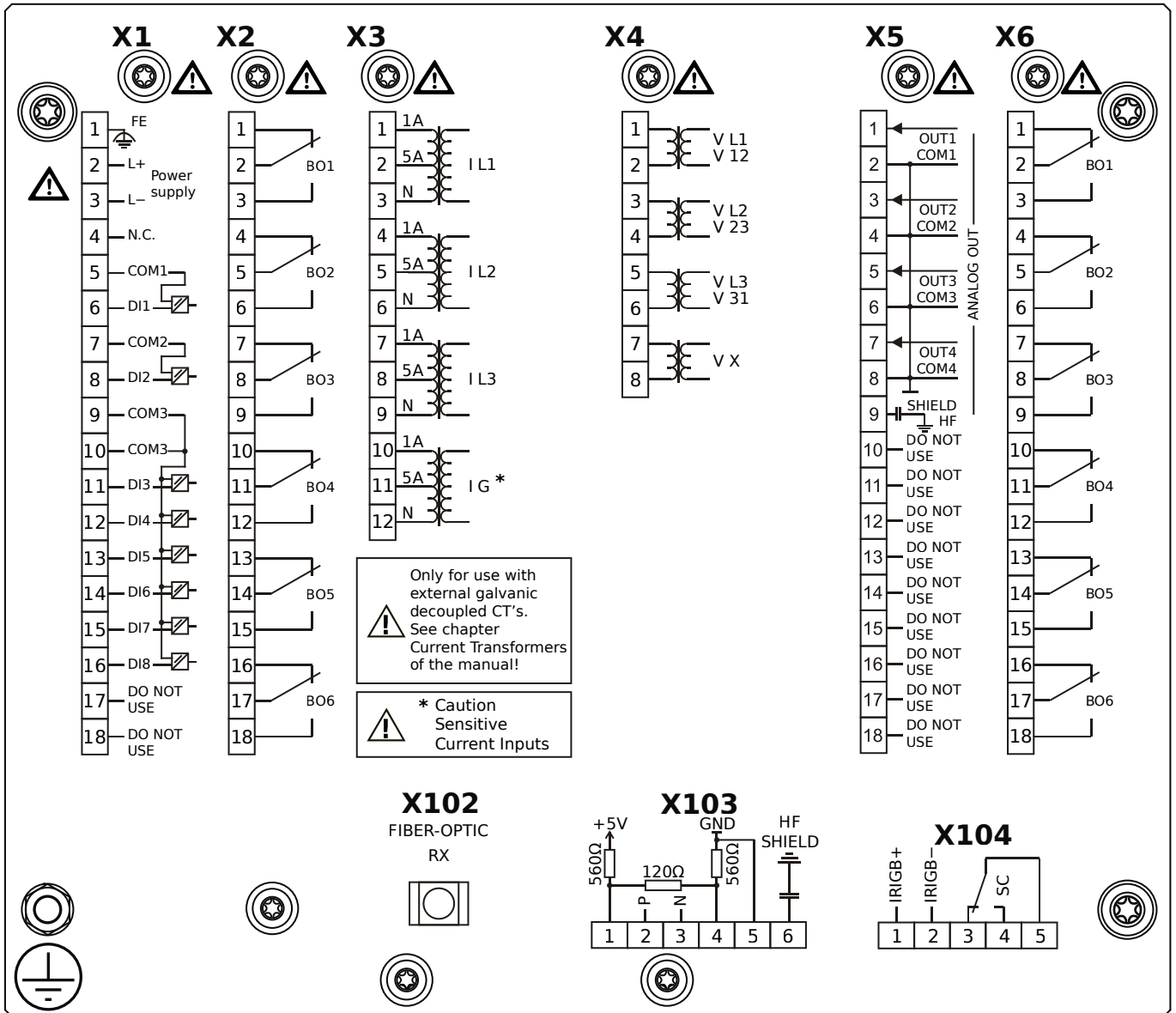

## Housing B2, small display, 19" rack mounting

- X1** – DI8-X1: Wide-range power supply unit, incl. 2 non-grouped digital inputs and 6 grouped digital inputs
- X2** – OR6: Assembly Group with 6 Output Relays (Changeover / Form C)
- X3** – TIs: Standard phase current measuring card and sensitive ground current measuring
- X4** – TU: Card with 4 voltage transformer measuring inputs (0 ... 800 VAC, under UL: 0 ... 600 VAC)
- X5** – AnO4: Analog Outputs
- X6** – OR6: Assembly Group with 6 Output Relays (Changeover / Form C)
- X102** – Universal Resistance-Temperature Detector (URTD) input, Fiber optics interface, Versatile Link
- X103** – Modbus RTU / IEC 60870-5-103 / DNP3.0 RTU, RS485, Terminals
- X104** – IRIG-B00X, incl. System Contact (Supervision Contact)

# MRMV4-2C1BBB

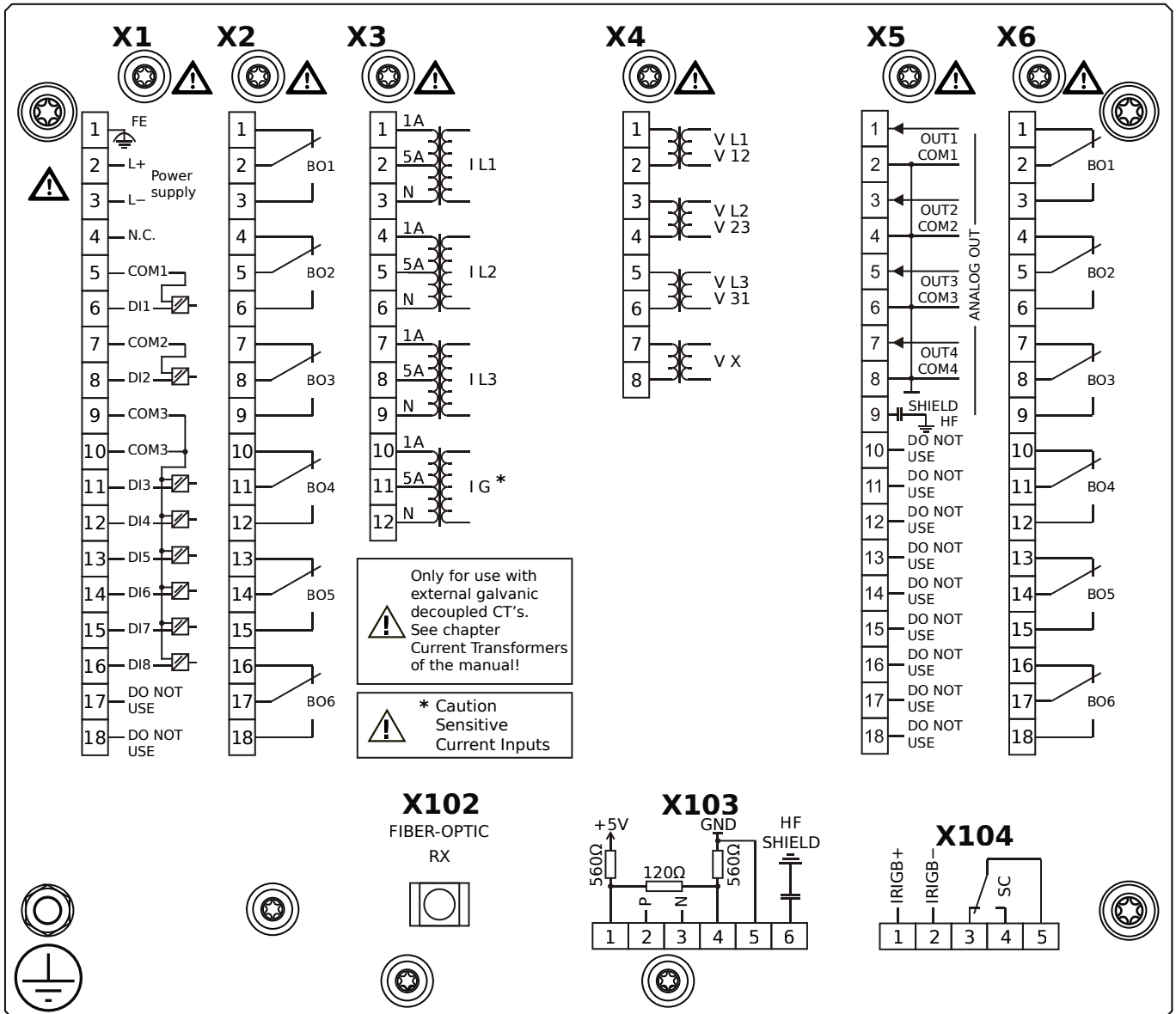

## Housing B2, small display, 19" rack mounting

+ Conformal Coating (for installations in harsh environment)

- X1** – DI8-X1: Wide-range power supply unit, incl. 2 non-grouped digital inputs and 6 grouped digital inputs
- X2** – OR6: Assembly Group with 6 Output Relays (Changeover / Form C)
- X3** – TIs: Standard phase current measuring card and sensitive ground current measuring
- X4** – TU: Card with 4 voltage transformer measuring inputs (0 ... 800 VAC, under UL: 0 ... 600 VAC)
- X5** – AnO4: Analog Outputs
- X6** – OR6: Assembly Group with 6 Output Relays (Changeover / Form C)
- X102** – Universal Resistance-Temperature Detector (URTD) input, Fiber optics interface, Versatile Link
- X103** – Modbus RTU / IEC 60870-5-103 / DNP3.0 RTU, RS485, Terminals
- X104** – IRIG-B00X, incl. System Contact (Supervision Contact)

# MRMV4-2C1BCA

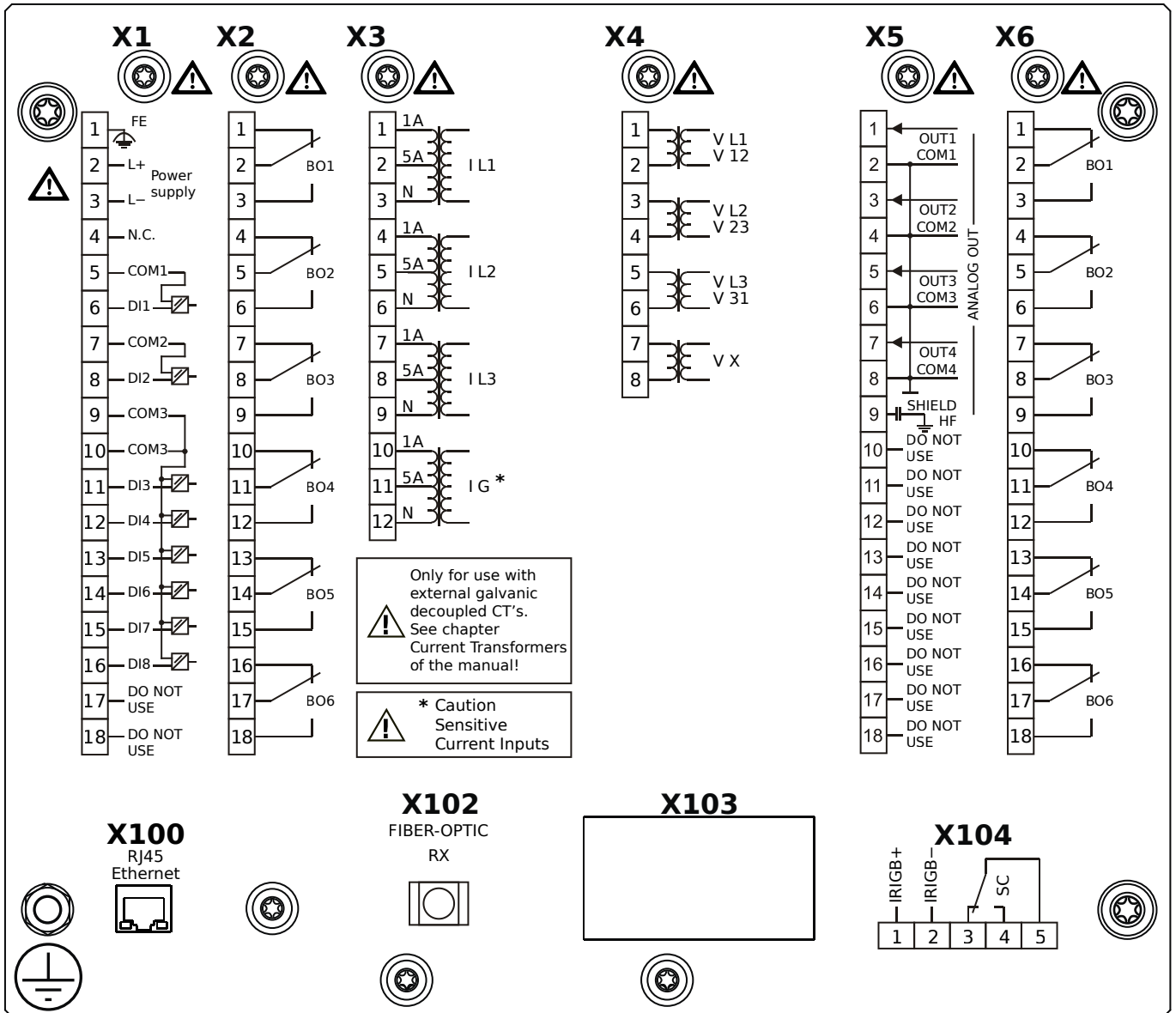

## Housing B2, small display, 19" rack mounting

- X1** – DI8-X1: Wide-range power supply unit, incl. 2 non-grouped digital inputs and 6 grouped digital inputs
- X2** – OR6: Assembly Group with 6 Output Relays (Changeover / Form C)
- X3** – TIs: Standard phase current measuring card and sensitive ground current measuring
- X4** – TU: Card with 4 voltage transformer measuring inputs (0 ... 800 VAC, under UL: 0 ... 600 VAC)
- X5** – AnO4: Analog Outputs
- X6** – OR6: Assembly Group with 6 Output Relays (Changeover / Form C)
- X100** – Modbus TCP / IEC 60870-5-104 / DNP3.0 TCP/UDP, Ethernet interface, 100 Mbit/s, RJ45 (BASE100-FX)
- X102** – Universal Resistance-Temperature Detector (URTD) input, Fiber optics interface, Versatile Link
- X104** – IRIG-B00X, incl. System Contact (Supervision Contact)

# MRMV4-2C1BCB

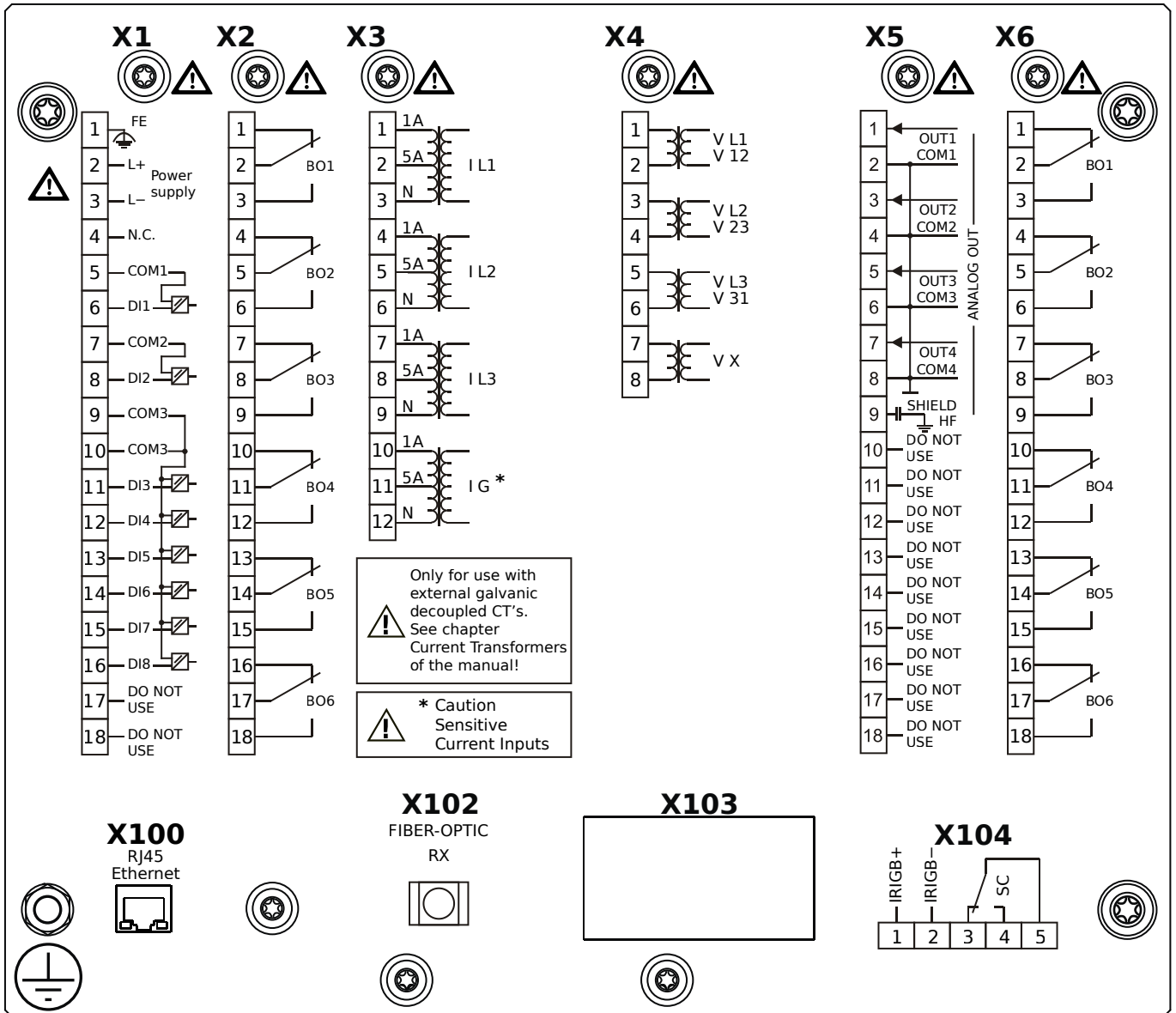

## Housing B2, small display, 19" rack mounting

+ Conformal Coating (for installations in harsh environment)

- X1** – DI8-X1: Wide-range power supply unit, incl. 2 non-grouped digital inputs and 6 grouped digital inputs
- X2** – OR6: Assembly Group with 6 Output Relays (Changeover / Form C)
- X3** – TIs: Standard phase current measuring card and sensitive ground current measuring
- X4** – TU: Card with 4 voltage transformer measuring inputs (0 ... 800 VAC, under UL: 0 ... 600 VAC)
- X5** – AnO4: Analog Outputs
- X6** – OR6: Assembly Group with 6 Output Relays (Changeover / Form C)
- X100** – Modbus TCP / IEC 60870-5-104 / DNP3.0 TCP/UDP, Ethernet interface, 100 Mbit/s, RJ45 (BASE100-FX)
- X102** – Universal Resistance-Temperature Detector (URTD) input, Fiber optics interface, Versatile Link
- X104** – IRIG-B00X, incl. System Contact (Supervision Contact)

# MRMV4-2C1BDA

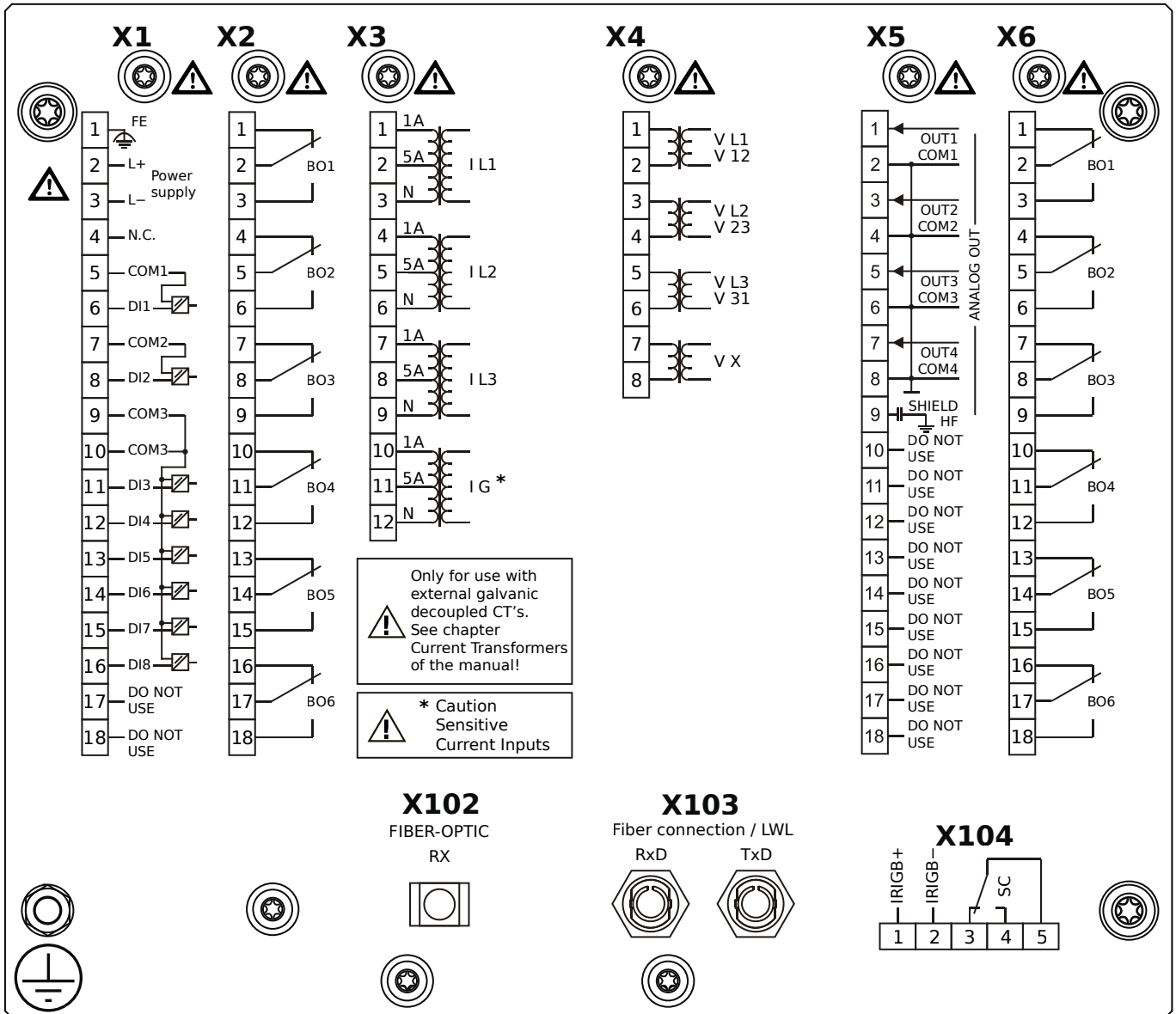

## Housing B2, small display, 19" rack mounting

- X1** – DI8-X1: Wide-range power supply unit, incl. 2 non-grouped digital inputs and 6 grouped digital inputs
- X2** – OR6: Assembly Group with 6 Output Relays (Changeover / Form C)
- X3** – TIs: Standard phase current measuring card and sensitive ground current measuring
- X4** – TU: Card with 4 voltage transformer measuring inputs (0 ... 800 VAC, under UL: 0 ... 600 VAC)
- X5** – AnO4: Analog Outputs
- X6** – OR6: Assembly Group with 6 Output Relays (Changeover / Form C)
- X102** – Universal Resistance-Temperature Detector (URTD) input, Fiber optics interface, Versatile Link
- X103** – Profibus-DP, Fiber optics interface, ST Connector
- X104** – IRIG-B00X, incl. System Contact (Supervision Contact)



# MRMV4-2C1BDB

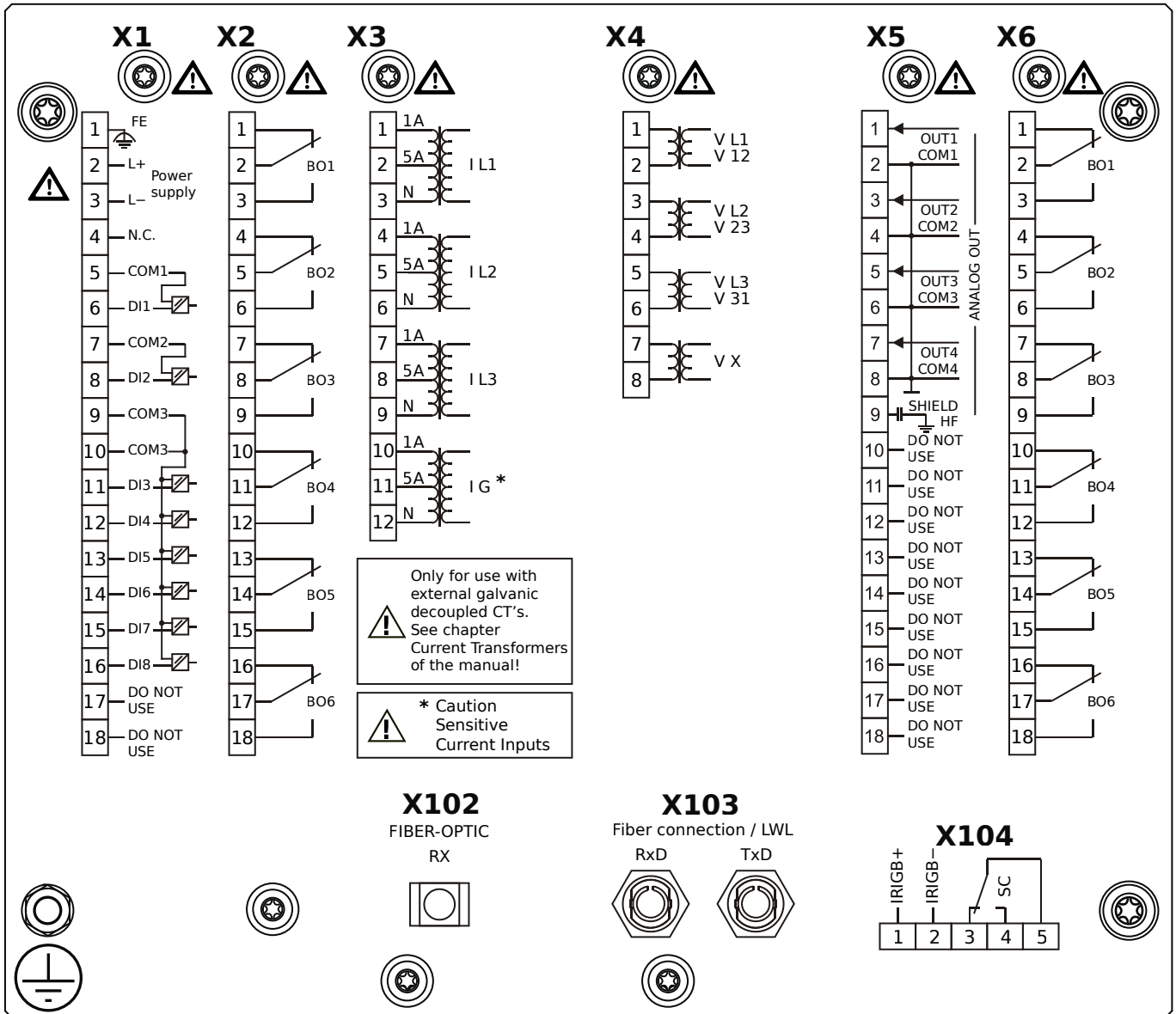

## Housing B2, small display, 19" rack mounting

+ Conformal Coating (for installations in harsh environment)

- X1** – DI8-X1: Wide-range power supply unit, incl. 2 non-grouped digital inputs and 6 grouped digital inputs
- X2** – OR6: Assembly Group with 6 Output Relays (Changeover / Form C)
- X3** – TIs: Standard phase current measuring card and sensitive ground current measuring
- X4** – TU: Card with 4 voltage transformer measuring inputs (0 ... 800 VAC, under UL: 0 ... 600 VAC)
- X5** – AnO4: Analog Outputs
- X6** – OR6: Assembly Group with 6 Output Relays (Changeover / Form C)
- X102** – Universal Resistance-Temperature Detector (URTD) input, Fiber optics interface, Versatile Link
- X103** – Profibus-DP, Fiber optics interface, ST Connector
- X104** – IRIG-B00X, incl. System Contact (Supervision Contact)

# MRMV4-2C1BEA

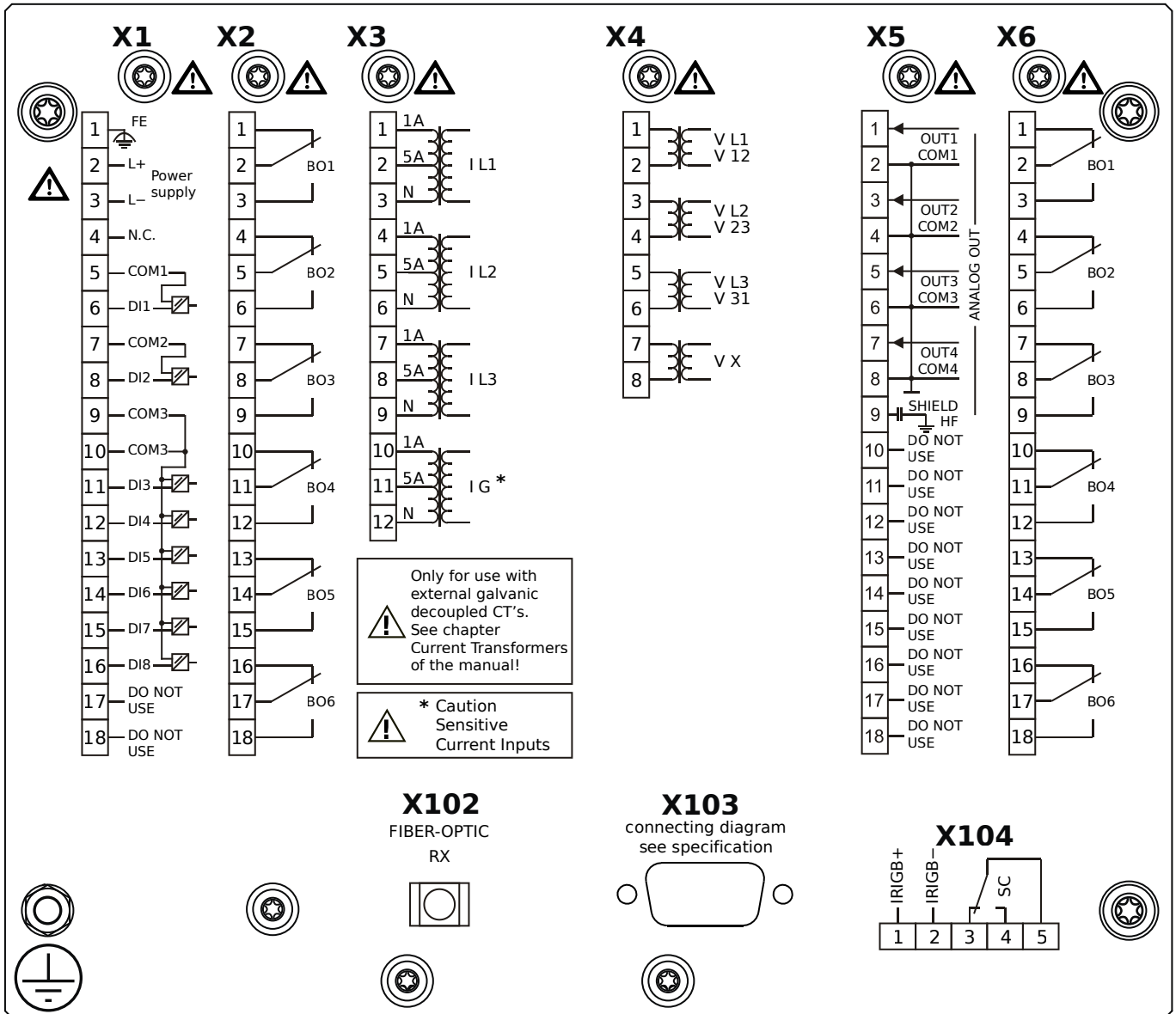

## Housing B2, small display, 19" rack mounting

- X1** – DI8-X1: Wide-range power supply unit, incl. 2 non-grouped digital inputs and 6 grouped digital inputs
- X2** – OR6: Assembly Group with 6 Output Relays (Changeover / Form C)
- X3** – TIs: Standard phase current measuring card and sensitive ground current measuring
- X4** – TU: Card with 4 voltage transformer measuring inputs (0 ... 800 VAC, under UL: 0 ... 600 VAC)
- X5** – AnO4: Analog Outputs
- X6** – OR6: Assembly Group with 6 Output Relays (Changeover / Form C)
- X102** – Universal Resistance-Temperature Detector (URTD) input, Fiber optics interface, Versatile Link
- X103** – Profibus-DP, RS485, D-SUB
- X104** – IRIG-B00X, incl. System Contact (Supervision Contact)

# MRMV4-2C1BEB

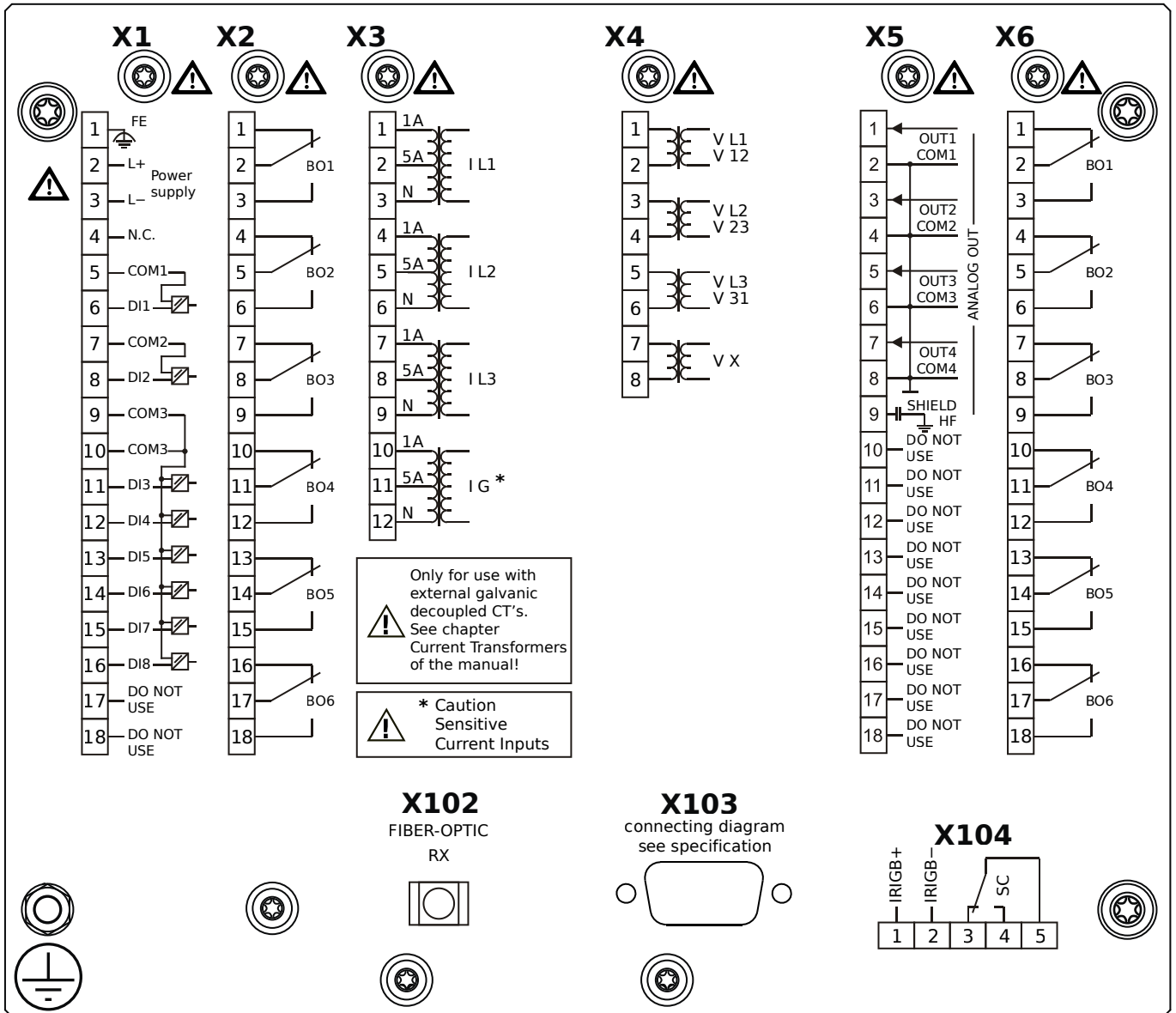

## Housing B2, small display, 19" rack mounting

+ Conformal Coating (for installations in harsh environment)

- X1** – DI8-X1: Wide-range power supply unit, incl. 2 non-grouped digital inputs and 6 grouped digital inputs
- X2** – OR6: Assembly Group with 6 Output Relays (Changeover / Form C)
- X3** – TIs: Standard phase current measuring card and sensitive ground current measuring
- X4** – TU: Card with 4 voltage transformer measuring inputs (0 ... 800 VAC, under UL: 0 ... 600 VAC)
- X5** – AnO4: Analog Outputs
- X6** – OR6: Assembly Group with 6 Output Relays (Changeover / Form C)
- X102** – Universal Resistance-Temperature Detector (URTD) input, Fiber optics interface, Versatile Link
- X103** – Profibus-DP, RS485, D-SUB
- X104** – IRIG-B00X, incl. System Contact (Supervision Contact)

# MRMV4-2C1BFA

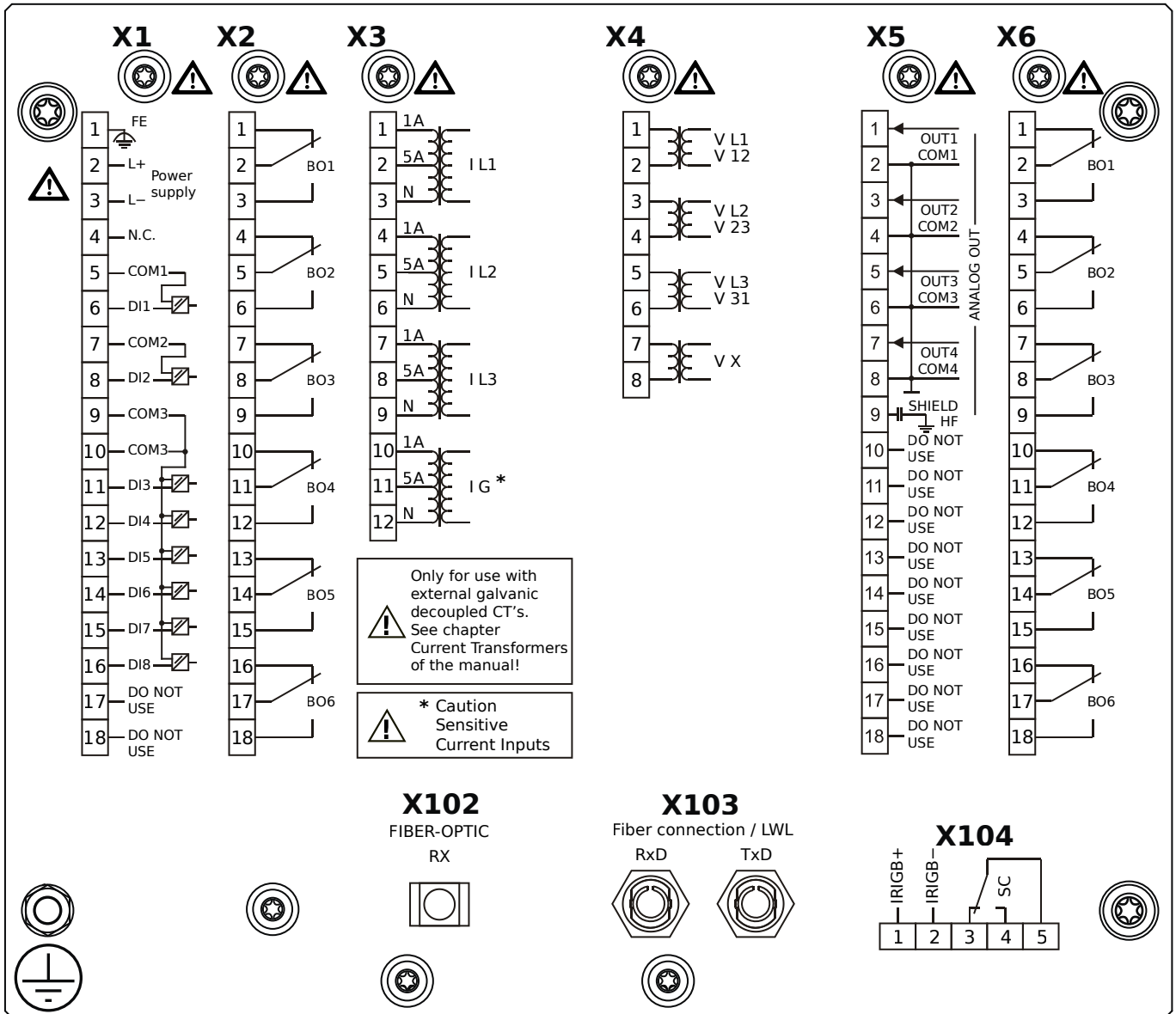

## Housing B2, small display, 19" rack mounting

- X1** – DI8-X1: Wide-range power supply unit, incl. 2 non-grouped digital inputs and 6 grouped digital inputs
- X2** – OR6: Assembly Group with 6 Output Relays (Changeover / Form C)
- X3** – TIs: Standard phase current measuring card and sensitive ground current measuring
- X4** – TU: Card with 4 voltage transformer measuring inputs (0 ... 800 VAC, under UL: 0 ... 600 VAC)
- X5** – AnO4: Analog Outputs
- X6** – OR6: Assembly Group with 6 Output Relays (Changeover / Form C)
- X102** – Universal Resistance-Temperature Detector (URTD) input, Fiber optics interface, Versatile Link
- X103** – Modbus RTU / IEC 60870-5-103 / DNP3.0 RTU, Fiber optics interface, ST Connector
- X104** – IRIG-B00X, incl. System Contact (Supervision Contact)

# MRMV4-2C1BFB

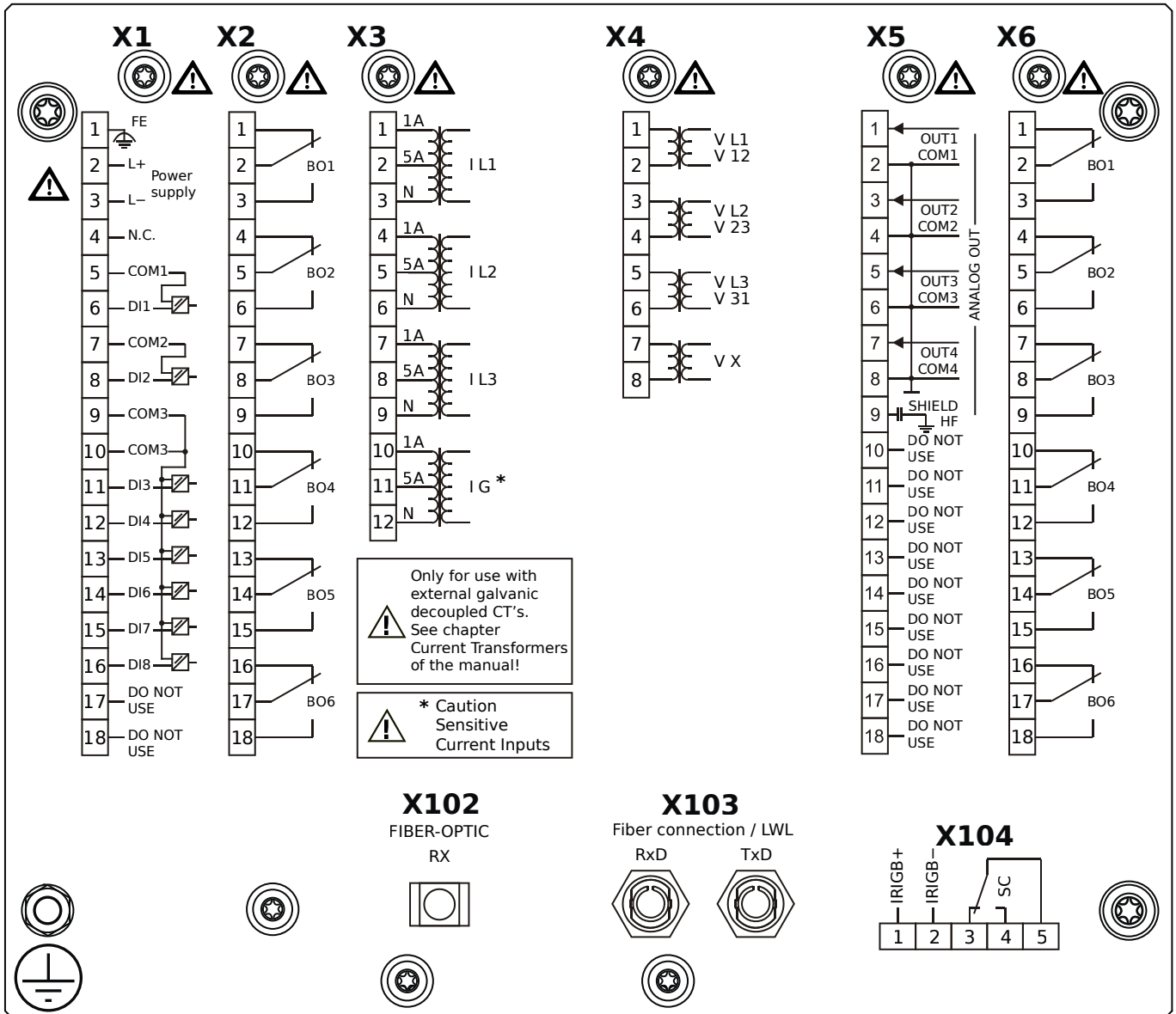

## Housing B2, small display, 19" rack mounting

- + Conformal Coating (for installations in harsh environment)
- X1** - DI8-X1: Wide-range power supply unit, incl. 2 non-grouped digital inputs and 6 grouped digital inputs
- X2** - OR6: Assembly Group with 6 Output Relays (Changeover / Form C)
- X3** - TIs: Standard phase current measuring card and sensitive ground current measuring
- X4** - TU: Card with 4 voltage transformer measuring inputs (0 ... 800 VAC, under UL: 0 ... 600 VAC)
- X5** - AnO4: Analog Outputs
- X6** - OR6: Assembly Group with 6 Output Relays (Changeover / Form C)
- X102** - Universal Resistance-Temperature Detector (URTD) input, Fiber optics interface, Versatile Link
- X103** - Modbus RTU / IEC 60870-5-103 / DNP3.0 RTU, Fiber optics interface, ST Connector
- X104** - IRIG-B00X, incl. System Contact (Supervision Contact)

# MRMV4-2C1BGA

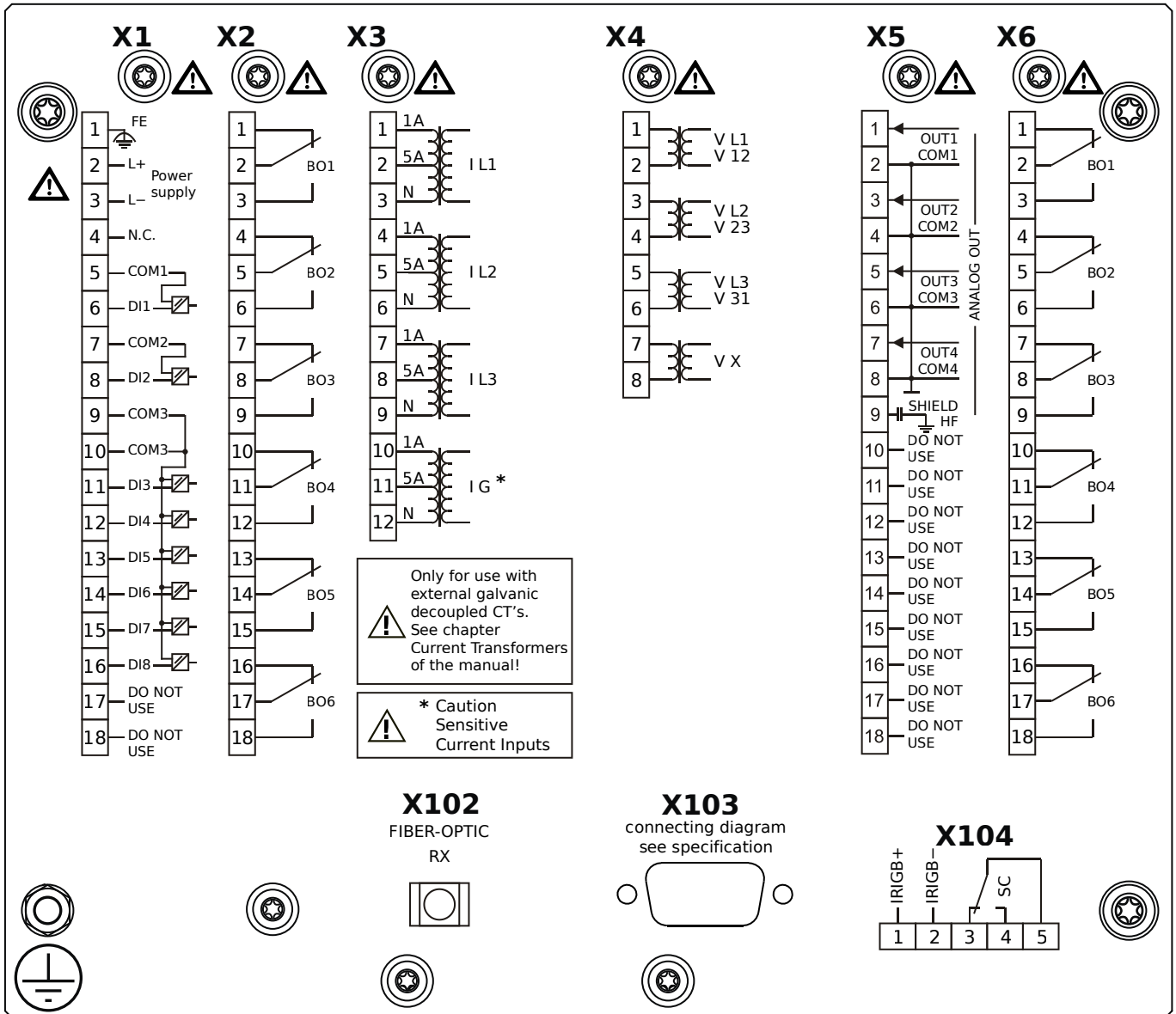

## Housing B2, small display, 19" rack mounting

- X1** – DI8-X1: Wide-range power supply unit, incl. 2 non-grouped digital inputs and 6 grouped digital inputs
- X2** – OR6: Assembly Group with 6 Output Relays (Changeover / Form C)
- X3** – TIs: Standard phase current measuring card and sensitive ground current measuring
- X4** – TU: Card with 4 voltage transformer measuring inputs (0 ... 800 VAC, under UL: 0 ... 600 VAC)
- X5** – AnO4: Analog Outputs
- X6** – OR6: Assembly Group with 6 Output Relays (Changeover / Form C)
- X102** – Universal Resistance-Temperature Detector (URTD) input, Fiber optics interface, Versatile Link
- X103** – Modbus RTU / IEC 60870-5-103 / DNP3.0 RTU, RS485, D-SUB
- X104** – IRIG-B00X, incl. System Contact (Supervision Contact)

# MRMV4-2C1BGB

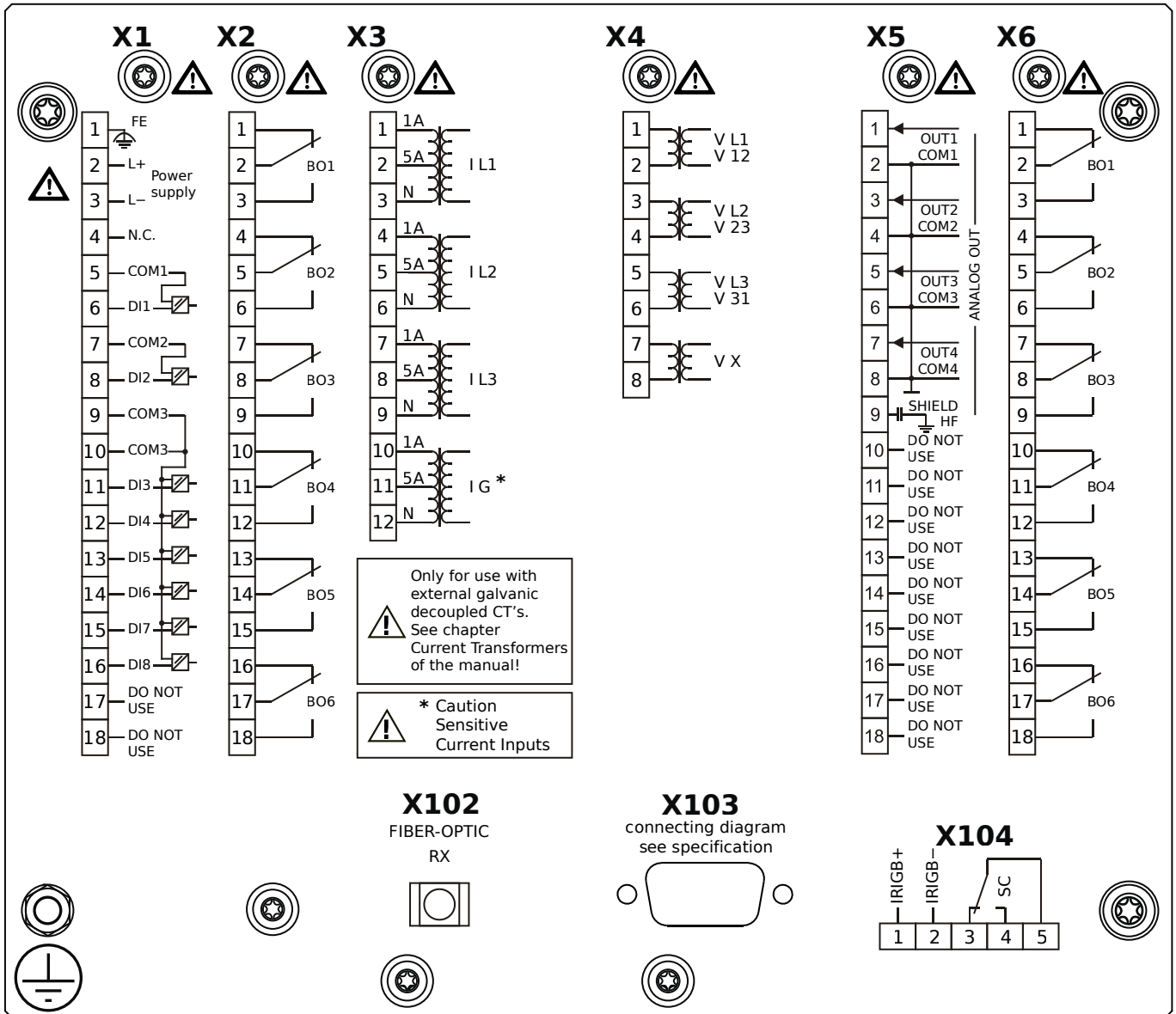

## Housing B2, small display, 19" rack mounting

+ Conformal Coating (for installations in harsh environment)

- X1** – DI8-X1: Wide-range power supply unit, incl. 2 non-grouped digital inputs and 6 grouped digital inputs
- X2** – OR6: Assembly Group with 6 Output Relays (Changeover / Form C)
- X3** – TIs: Standard phase current measuring card and sensitive ground current measuring
- X4** – TU: Card with 4 voltage transformer measuring inputs (0 ... 800 VAC, under UL: 0 ... 600 VAC)
- X5** – AnO4: Analog Outputs
- X6** – OR6: Assembly Group with 6 Output Relays (Changeover / Form C)
- X102** – Universal Resistance-Temperature Detector (URTD) input, Fiber optics interface, Versatile Link
- X103** – Modbus RTU / IEC 60870-5-103 / DNP3.0 RTU, RS485, D-SUB
- X104** – IRIG-B00X, incl. System Contact (Supervision Contact)

# MRMV4-2C1BHA

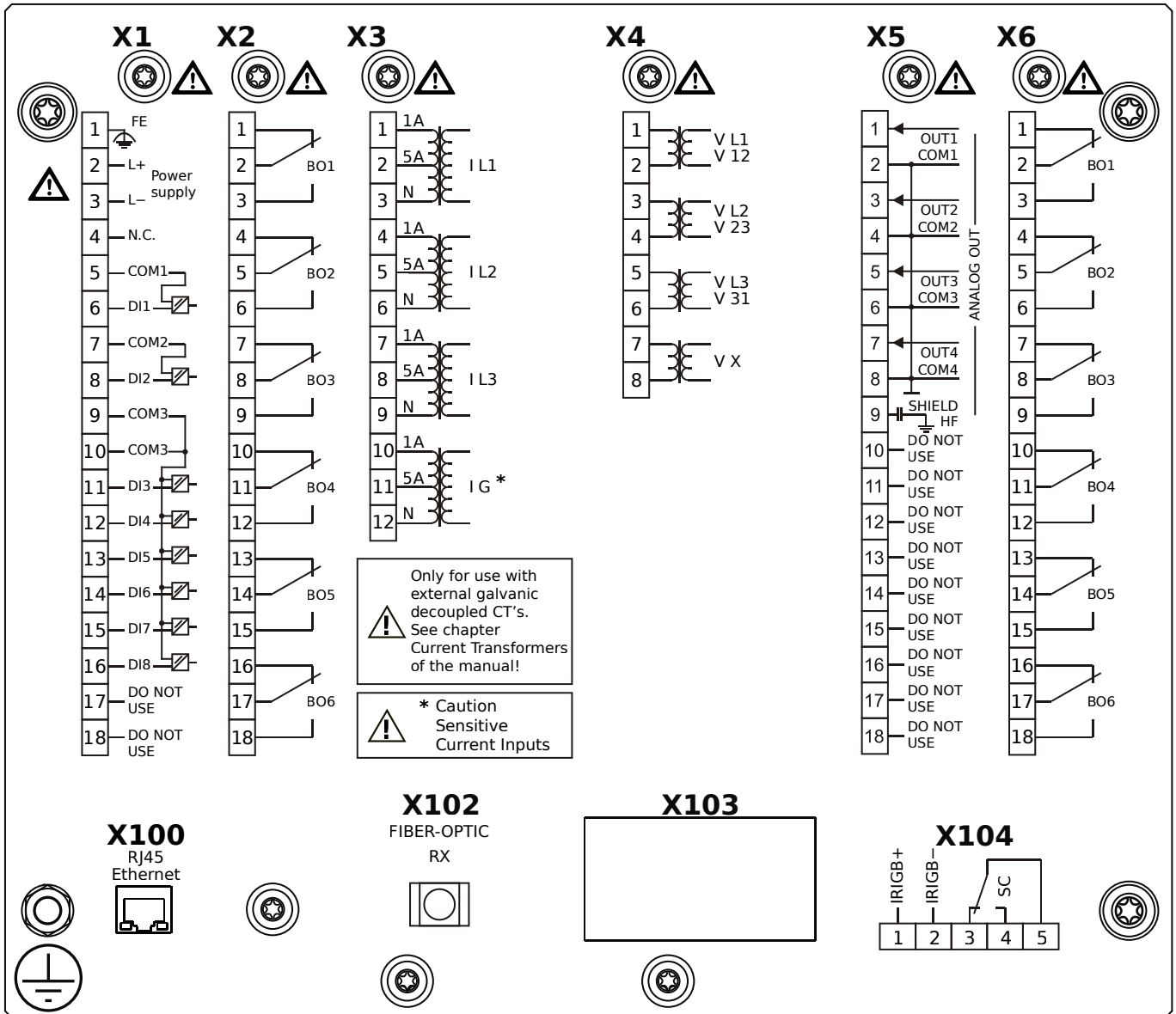

## Housing B2, small display, 19" rack mounting

- X1** – DI8-X1: Wide-range power supply unit, incl. 2 non-grouped digital inputs and 6 grouped digital inputs
- X2** – OR6: Assembly Group with 6 Output Relays (Changeover / Form C)
- X3** – TIs: Standard phase current measuring card and sensitive ground current measuring
- X4** – TU: Card with 4 voltage transformer measuring inputs (0 ... 800 VAC, under UL: 0 ... 600 VAC)
- X5** – AnO4: Analog Outputs
- X6** – OR6: Assembly Group with 6 Output Relays (Changeover / Form C)
- X100** – IEC 61850 / Modbus TCP / IEC 60870-5-104 / DNP3.0 TCP/UDP, Ethernet interface, 100 Mbit/s, RJ45 (BASE100-FX)
- X102** – Universal Resistance-Temperature Detector (URTD) input, Fiber optics interface, Versatile Link
- X104** – IRIG-B00X, incl. System Contact (Supervision Contact)



# MRMV4-2C1BHB

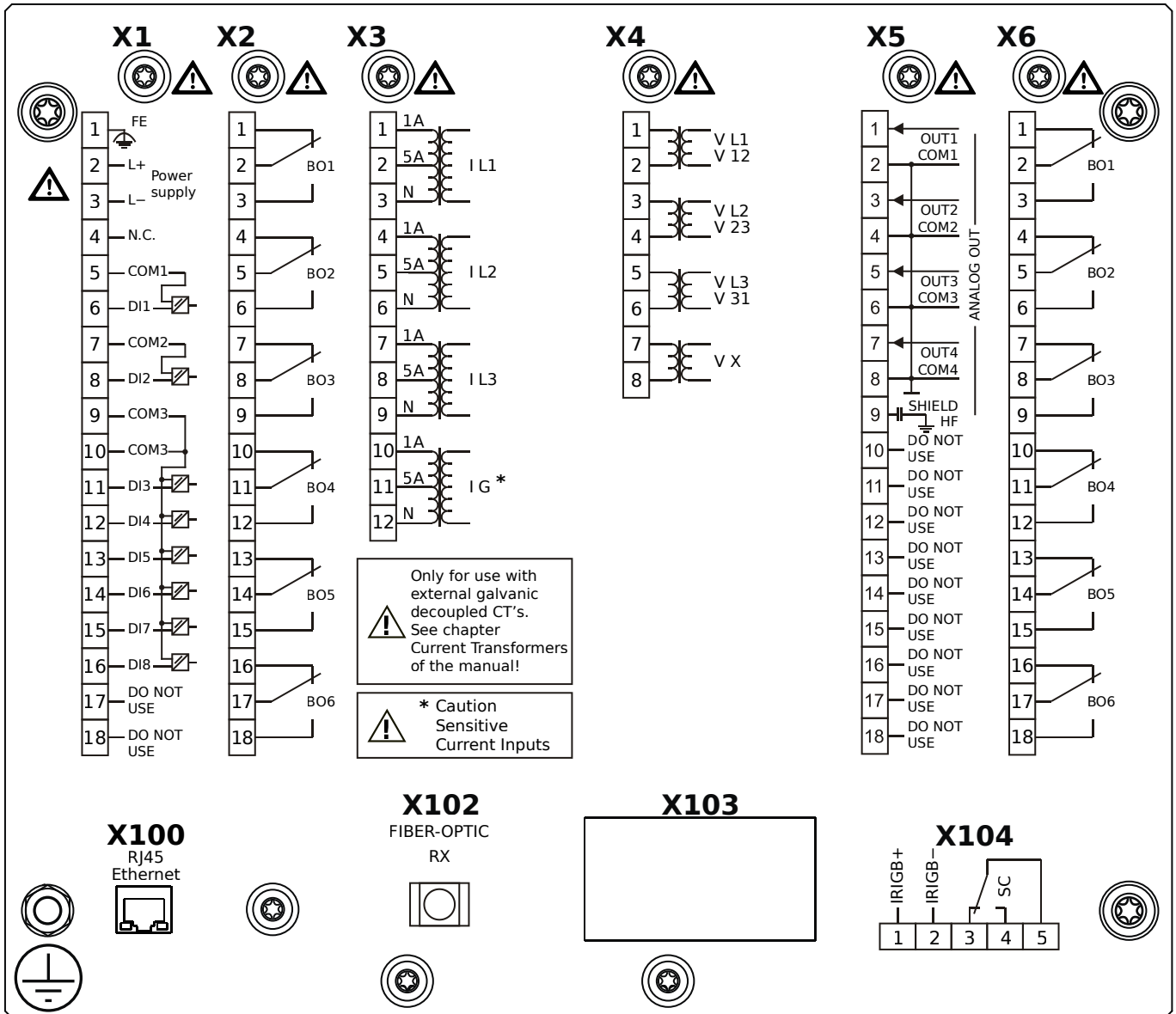

## Housing B2, small display, 19" rack mounting

+ Conformal Coating (for installations in harsh environment)

- X1** – DI8-X1: Wide-range power supply unit, incl. 2 non-grouped digital inputs and 6 grouped digital inputs
- X2** – OR6: Assembly Group with 6 Output Relays (Changeover / Form C)
- X3** – TIs: Standard phase current measuring card and sensitive ground current measuring
- X4** – TU: Card with 4 voltage transformer measuring inputs (0 ... 800 VAC, under UL: 0 ... 600 VAC)
- X5** – AnO4: Analog Outputs
- X6** – OR6: Assembly Group with 6 Output Relays (Changeover / Form C)
- X100** – IEC 61850 / Modbus TCP / IEC 60870-5-104 / DNP3.0 TCP/UDP, Ethernet interface, 100 Mbit/s, RJ45 (BASE100-FX)
- X102** – Universal Resistance-Temperature Detector (URTD) input, Fiber optics interface, Versatile Link
- X104** – IRIG-B00X, incl. System Contact (Supervision Contact)

# MRMV4-2C1BIA

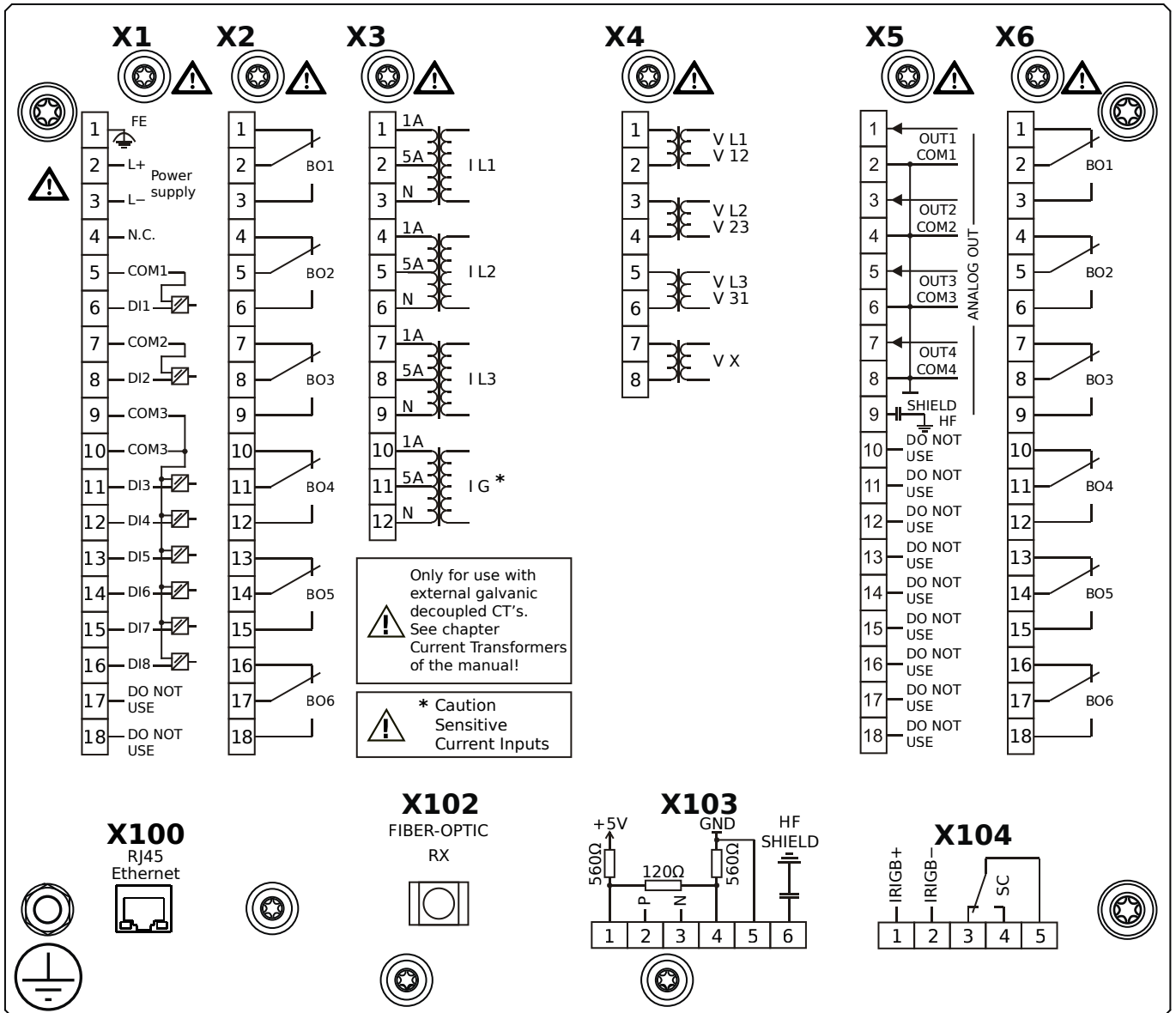

## Housing B2, small display, 19" rack mounting

- X1** – DI8-X1: Wide-range power supply unit, incl. 2 non-grouped digital inputs and 6 grouped digital inputs
- X2** – OR6: Assembly Group with 6 Output Relays (Changeover / Form C)
- X3** – TIs: Standard phase current measuring card and sensitive ground current measuring
- X4** – TU: Card with 4 voltage transformer measuring inputs (0 ... 800 VAC, under UL: 0 ... 600 VAC)
- X5** – AnO4: Analog Outputs
- X6** – OR6: Assembly Group with 6 Output Relays (Changeover / Form C)
- X100** – Modbus TCP / IEC 60870-5-104 / DNP3.0 TCP/UDP, Ethernet interface, 100 Mbit/s, RJ45 (BASE100-FX)
- X102** – Universal Resistance-Temperature Detector (URTD) input, Fiber optics interface, Versatile Link
- X103** – IEC 60870-5-103 / Modbus RTU / DNP3.0 RTU, RS485, Terminals
- X104** – IRIG-B00X, incl. System Contact (Supervision Contact)

# MRMV4-2C1BIB

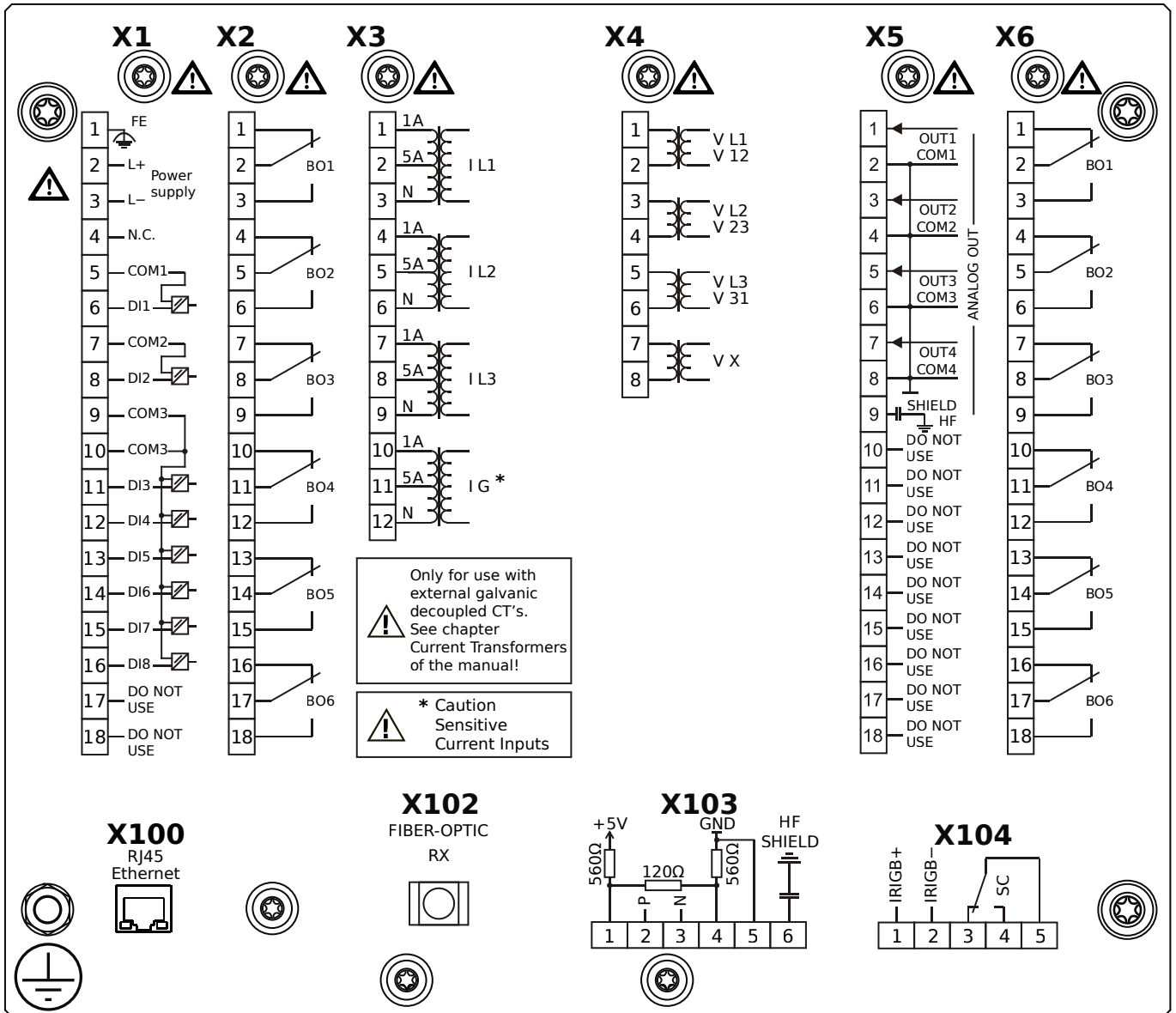

## Housing B2, small display, 19" rack mounting

+ Conformal Coating (for installations in harsh environment)

- X1** – DI8-X1: Wide-range power supply unit, incl. 2 non-grouped digital inputs and 6 grouped digital inputs
- X2** – OR6: Assembly Group with 6 Output Relays (Changeover / Form C)
- X3** – TIs: Standard phase current measuring card and sensitive ground current measuring
- X4** – TU: Card with 4 voltage transformer measuring inputs (0 ... 800 VAC, under UL: 0 ... 600 VAC)
- X5** – AnO4: Analog Outputs
- X6** – OR6: Assembly Group with 6 Output Relays (Changeover / Form C)
- X100** – Modbus TCP / IEC 60870-5-104 / DNP3.0 TCP/UDP, Ethernet interface, 100 Mbit/s, RJ45 (BASE100-FX)
- X102** – Universal Resistance-Temperature Detector (URTD) input, Fiber optics interface, Versatile Link
- X103** – IEC 60870-5-103 / Modbus RTU / DNP3.0 RTU, RS485, Terminals
- X104** – IRIG-B00X, incl. System Contact (Supervision Contact)

# MRMV4-2C1BKA

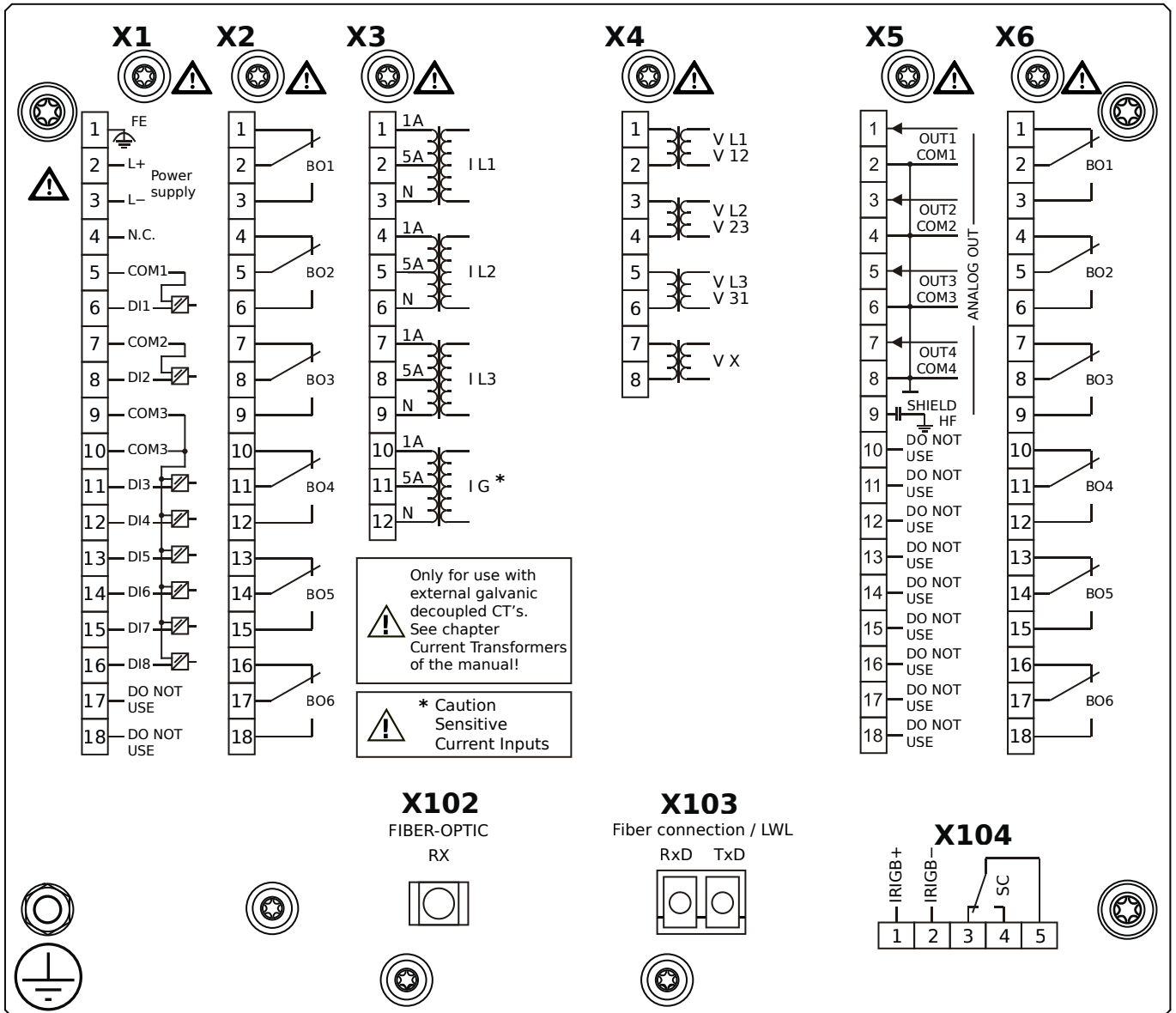

## Housing B2, small display, 19" rack mounting

- X1** – DI8-X1: Wide-range power supply unit, incl. 2 non-grouped digital inputs and 6 grouped digital inputs
- X2** – OR6: Assembly Group with 6 Output Relays (Changeover / Form C)
- X3** – TIs: Standard phase current measuring card and sensitive ground current measuring
- X4** – TU: Card with 4 voltage transformer measuring inputs (0 ... 800 VAC, under UL: 0 ... 600 VAC)
- X5** – AnO4: Analog Outputs
- X6** – OR6: Assembly Group with 6 Output Relays (Changeover / Form C)
- X102** – Universal Resistance-Temperature Detector (URTD) input, Fiber optics interface, Versatile Link
- X103** – IEC 61850 / Modbus TCP / IEC 60870-5-104 / DNP3.0 TCP/UDP, Fiber optics interface, LC Connector
- X104** – IRIG-B00X, incl. System Contact (Supervision Contact)

# MRMV4-2C1BKB

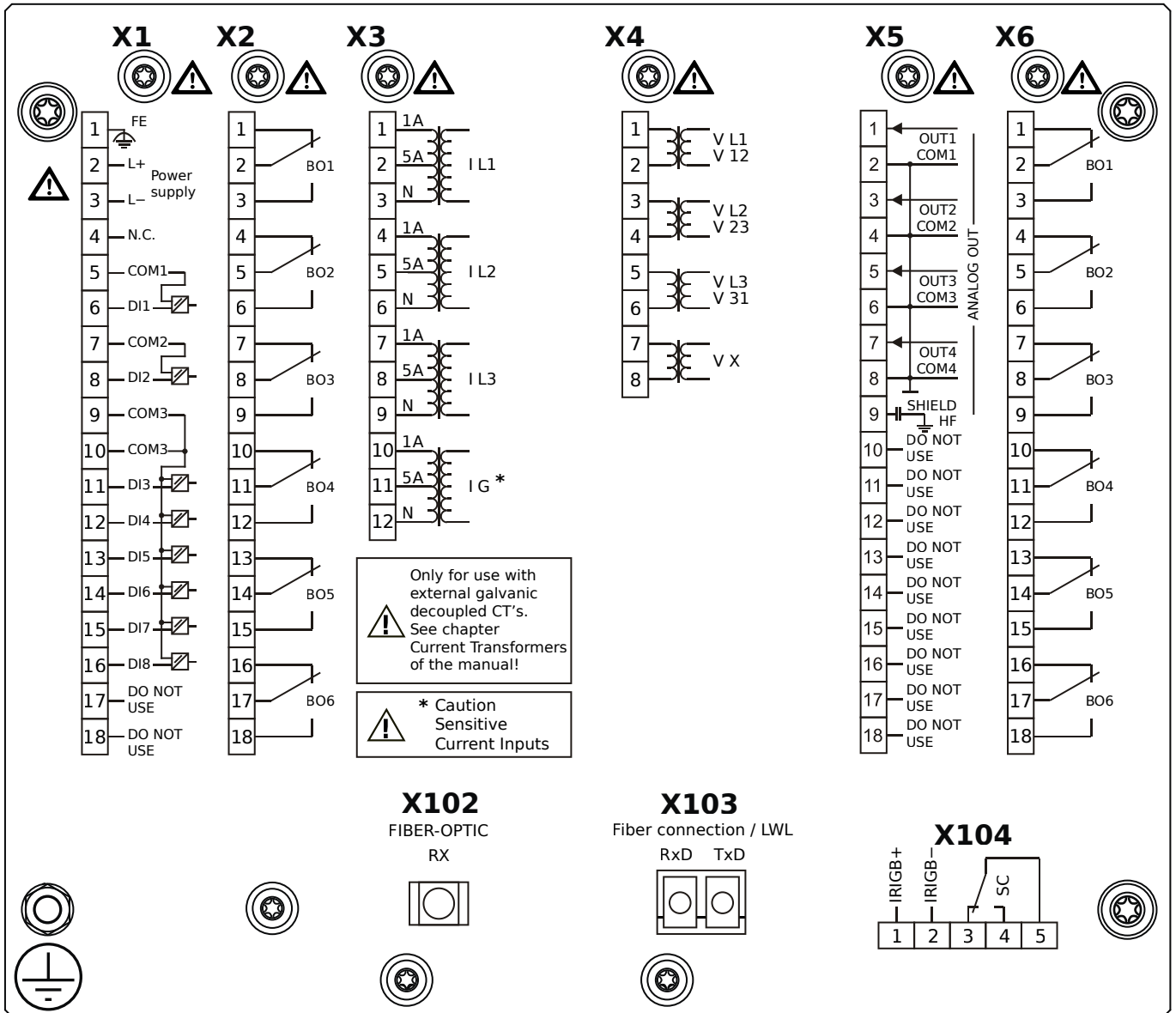

## Housing B2, small display, 19" rack mounting

+ Conformal Coating (for installations in harsh environment)

- X1** – DI8-X1: Wide-range power supply unit, incl. 2 non-grouped digital inputs and 6 grouped digital inputs
- X2** – OR6: Assembly Group with 6 Output Relays (Changeover / Form C)
- X3** – TIs: Standard phase current measuring card and sensitive ground current measuring
- X4** – TU: Card with 4 voltage transformer measuring inputs (0 ... 800 VAC, under UL: 0 ... 600 VAC)
- X5** – AnO4: Analog Outputs
- X6** – OR6: Assembly Group with 6 Output Relays (Changeover / Form C)
- X102** – Universal Resistance-Temperature Detector (URTD) input, Fiber optics interface, Versatile Link
- X103** – IEC 61850 / Modbus TCP / IEC 60870-5-104 / DNP3.0 TCP/UDP, Fiber optics interface, LC Connector
- X104** – IRIG-B00X, incl. System Contact (Supervision Contact)

# MRMV4-2C1BLA

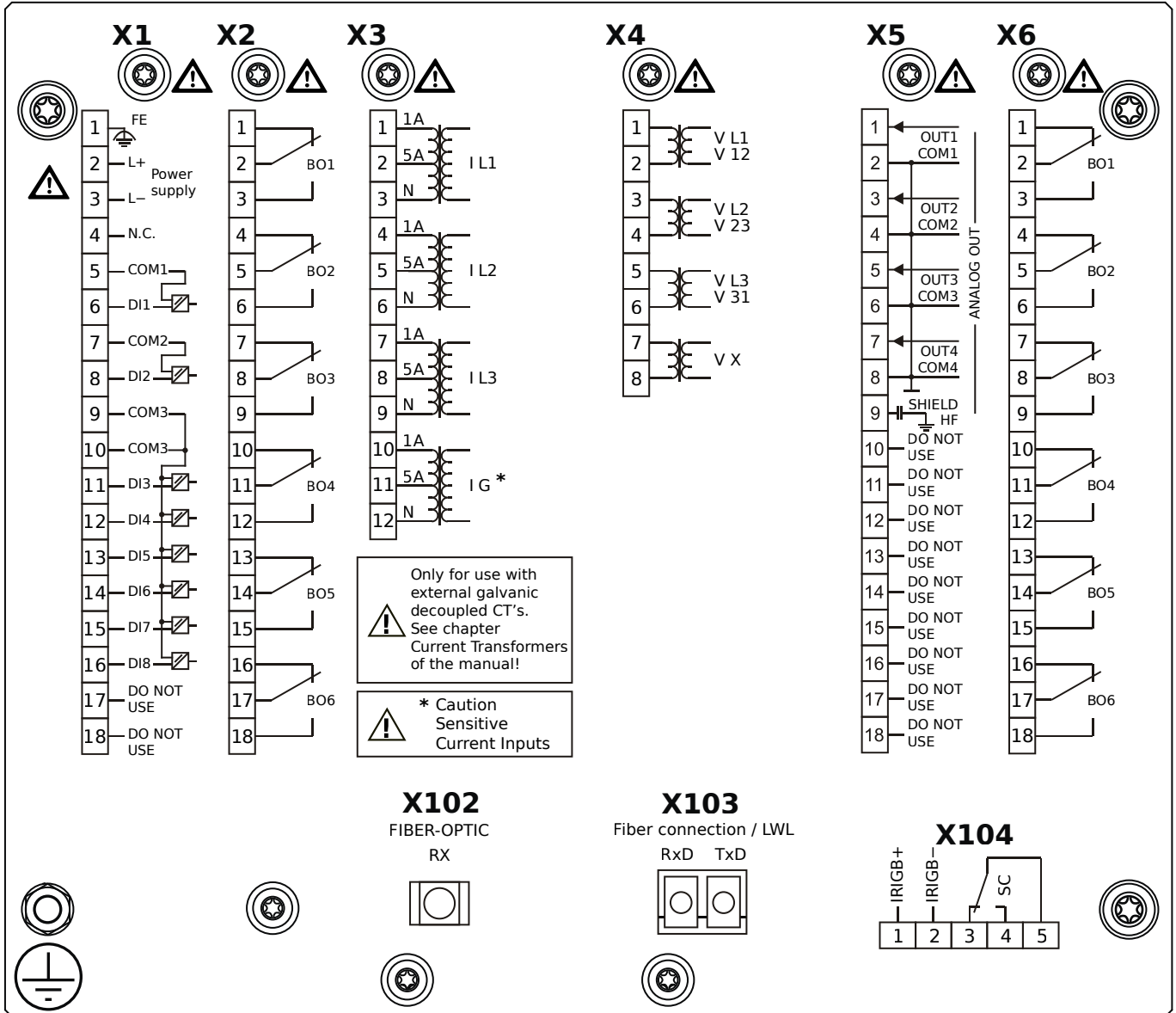

## Housing B2, small display, 19" rack mounting

- X1** – DI8-X1: Wide-range power supply unit, incl. 2 non-grouped digital inputs and 6 grouped digital inputs
- X2** – OR6: Assembly Group with 6 Output Relays (Changeover / Form C)
- X3** – TIs: Standard phase current measuring card and sensitive ground current measuring
- X4** – TU: Card with 4 voltage transformer measuring inputs (0 ... 800 VAC, under UL: 0 ... 600 VAC)
- X5** – AnO4: Analog Outputs
- X6** – OR6: Assembly Group with 6 Output Relays (Changeover / Form C)
- X102** – Universal Resistance-Temperature Detector (URTD) input, Fiber optics interface, Versatile Link
- X103** – Modbus TCP / IEC 60870-5-104 / DNP3.0 TCP/UDP, Fiber optics interface, LC Connector
- X104** – IRIG-B00X, incl. System Contact (Supervision Contact)

# MRMV4-2C1BLB

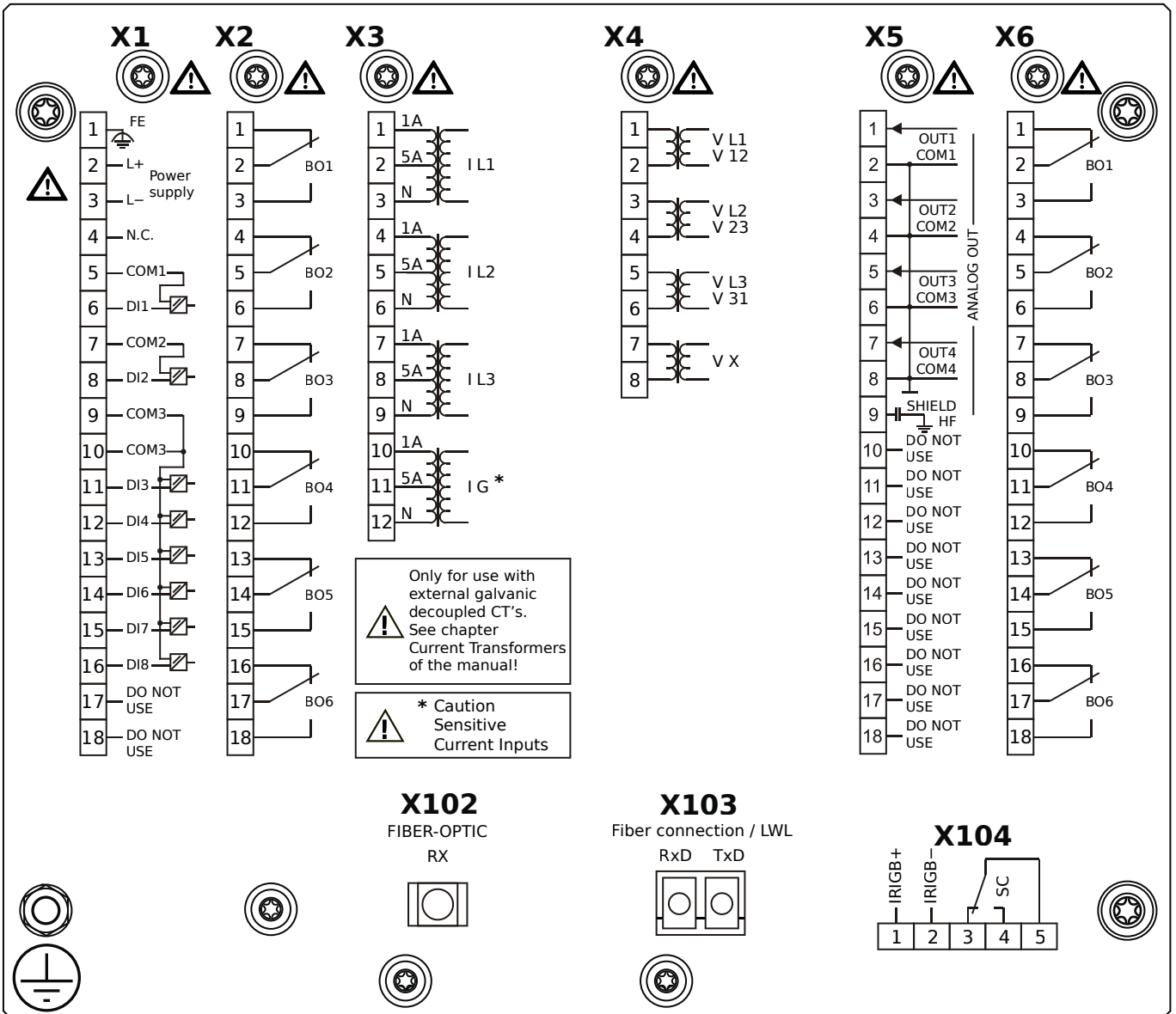

## Housing B2, small display, 19" rack mounting

+ Conformal Coating (for installations in harsh environment)

- X1** – DI8-X1: Wide-range power supply unit, incl. 2 non-grouped digital inputs and 6 grouped digital inputs
- X2** – OR6: Assembly Group with 6 Output Relays (Changeover / Form C)
- X3** – TIs: Standard phase current measuring card and sensitive ground current measuring
- X4** – TU: Card with 4 voltage transformer measuring inputs (0 ... 800 VAC, under UL: 0 ... 600 VAC)
- X5** – AnO4: Analog Outputs
- X6** – OR6: Assembly Group with 6 Output Relays (Changeover / Form C)
- X102** – Universal Resistance-Temperature Detector (URTD) input, Fiber optics interface, Versatile Link
- X103** – Modbus TCP / IEC 60870-5-104 / DNP3.0 TCP/UDP, Fiber optics interface, LC Connector
- X104** – IRIG-B00X, incl. System Contact (Supervision Contact)

# MRMV4-2C1BOA

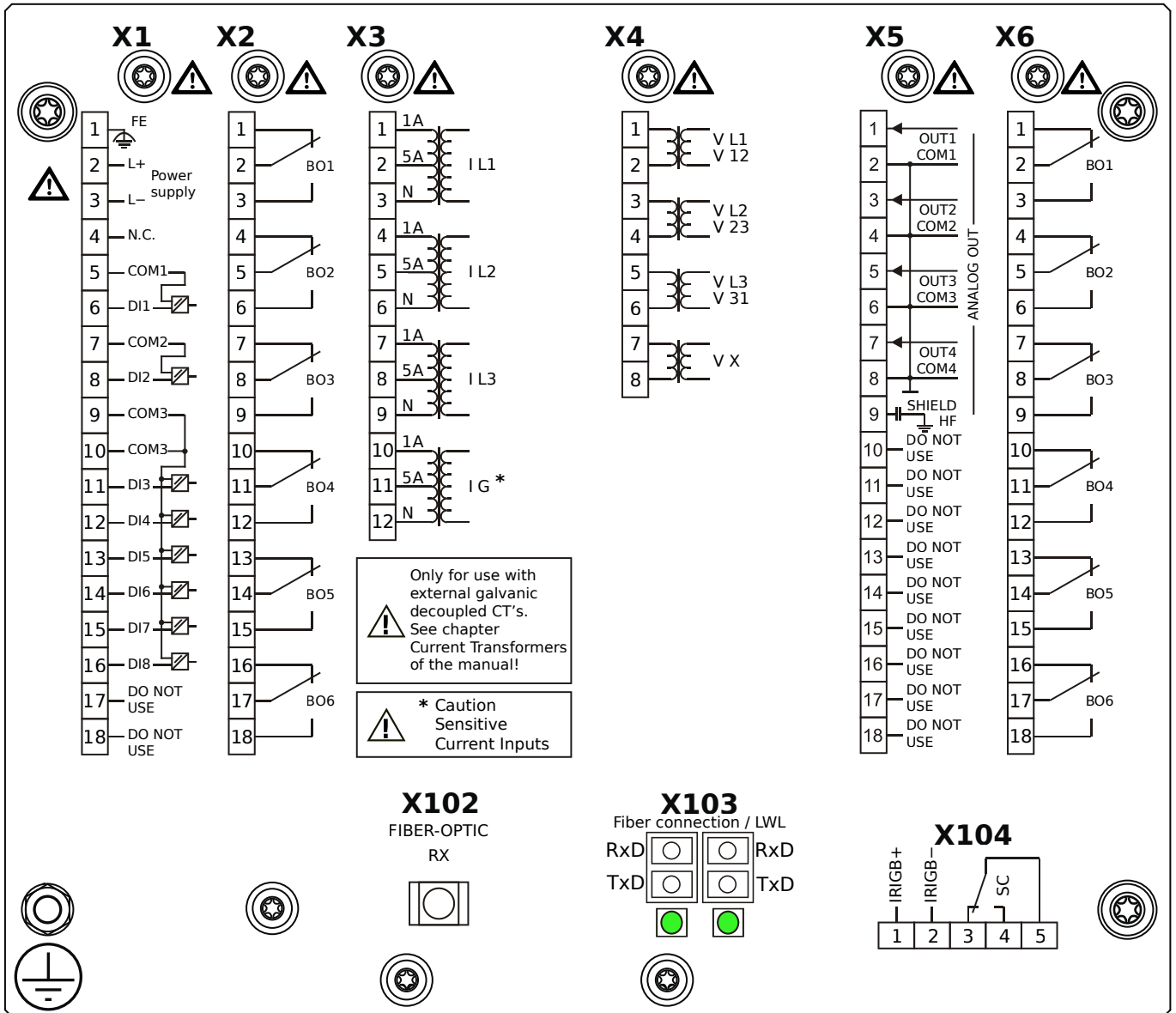

## Housing B2, small display, 19" rack mounting

- X1** – DI8-X1: Wide-range power supply unit, incl. 2 non-grouped digital inputs and 6 grouped digital inputs
- X2** – OR6: Assembly Group with 6 Output Relays (Changeover / Form C)
- X3** – TIs: Standard phase current measuring card and sensitive ground current measuring
- X4** – TU: Card with 4 voltage transformer measuring inputs (0 ... 800 VAC, under UL: 0 ... 600 VAC)
- X5** – AnO4: Analog Outputs
- X6** – OR6: Assembly Group with 6 Output Relays (Changeover / Form C)
- X102** – Universal Resistance-Temperature Detector (URTD) input, Fiber optics interface, Versatile Link
- X103** – Modbus TCP / IEC 60870-5-104 / DNP3.0 TCP/UDP, Redundant Fiber optics interface, LC Connector
- X104** – IRIG-B00X, incl. System Contact (Supervision Contact)



# MRMV4-2C1BOB

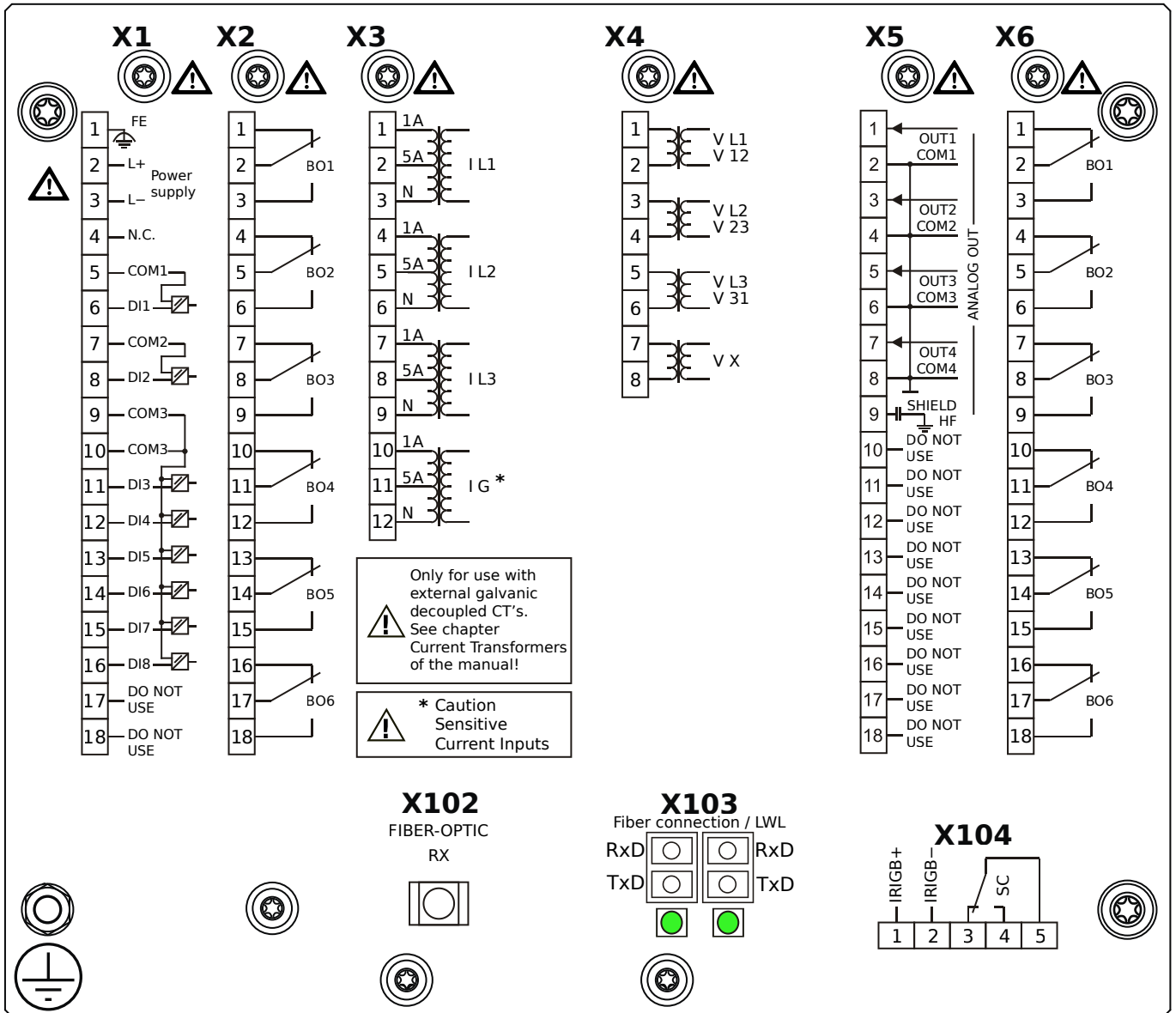

## Housing B2, small display, 19" rack mounting

+ Conformal Coating (for installations in harsh environment)

- X1** – DI8-X1: Wide-range power supply unit, incl. 2 non-grouped digital inputs and 6 grouped digital inputs
- X2** – OR6: Assembly Group with 6 Output Relays (Changeover / Form C)
- X3** – TIs: Standard phase current measuring card and sensitive ground current measuring
- X4** – TU: Card with 4 voltage transformer measuring inputs (0 ... 800 VAC, under UL: 0 ... 600 VAC)
- X5** – AnO4: Analog Outputs
- X6** – OR6: Assembly Group with 6 Output Relays (Changeover / Form C)
- X102** – Universal Resistance-Temperature Detector (URTD) input, Fiber optics interface, Versatile Link
- X103** – Modbus TCP / IEC 60870-5-104 / DNP3.0 TCP/UDP, Redundant Fiber optics interface, LC Connector
- X104** – IRIG-B00X, incl. System Contact (Supervision Contact)

# MRMV4-2C1BPA

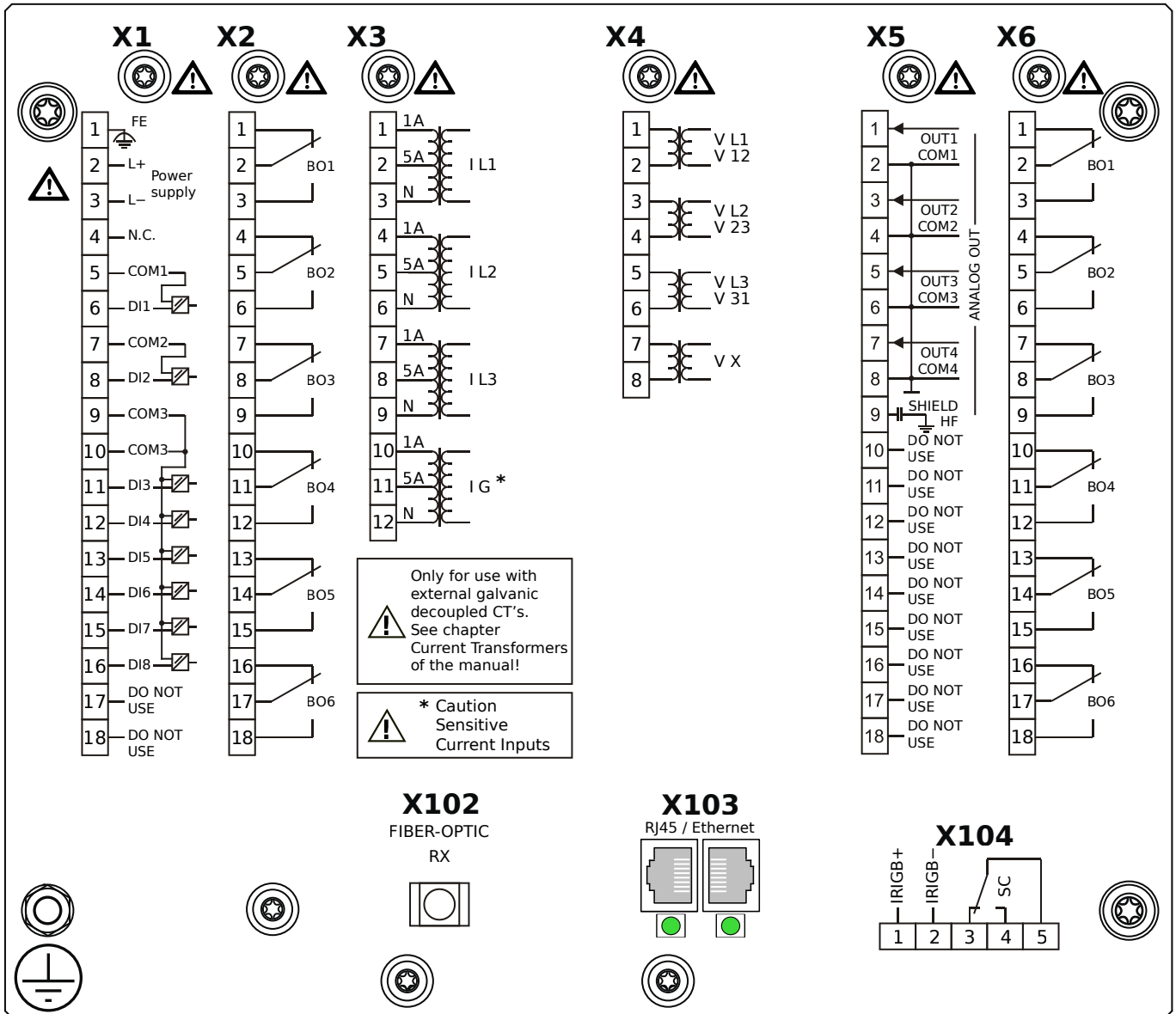

## Housing B2, small display, 19" rack mounting

- X1** – DI8-X1: Wide-range power supply unit, incl. 2 non-grouped digital inputs and 6 grouped digital inputs
- X2** – OR6: Assembly Group with 6 Output Relays (Changeover / Form C)
- X3** – TIs: Standard phase current measuring card and sensitive ground current measuring
- X4** – TU: Card with 4 voltage transformer measuring inputs (0 ... 800 VAC, under UL: 0 ... 600 VAC)
- X5** – AnO4: Analog Outputs
- X6** – OR6: Assembly Group with 6 Output Relays (Changeover / Form C)
- X102** – Universal Resistance-Temperature Detector (URTD) input, Fiber optics interface, Versatile Link
- X103** – Modbus TCP / IEC 60870-5-104 / DNP3.0 TCP/UDP, Redundant Ethernet interface, 100 Mbit/s, RJ45 (BASE100-FX)
- X104** – IRIG-B00X, incl. System Contact (Supervision Contact)

# MRMV4-2C1BPB

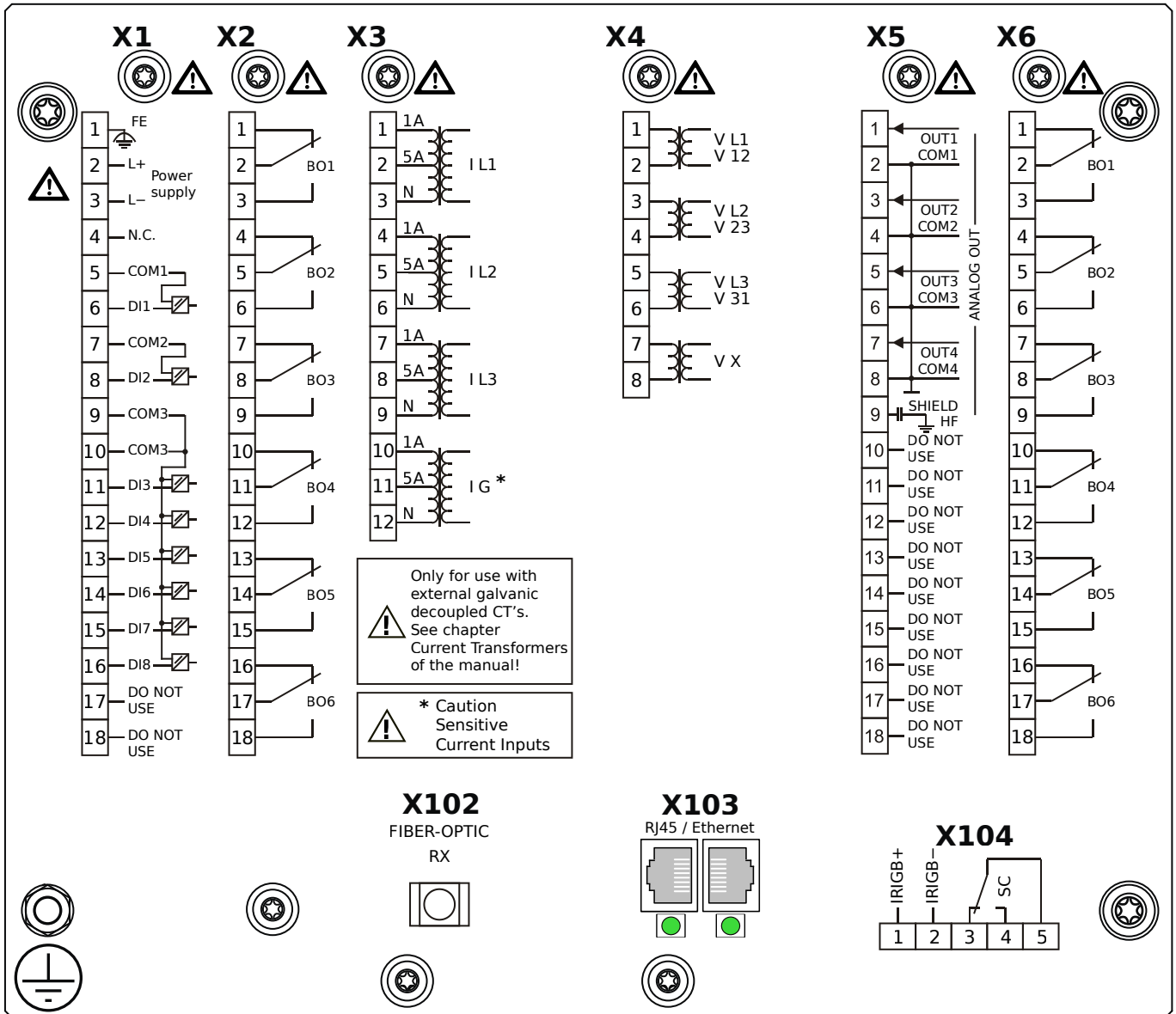

## Housing B2, small display, 19" rack mounting

+ Conformal Coating (for installations in harsh environment)

- X1** – DI8-X1: Wide-range power supply unit, incl. 2 non-grouped digital inputs and 6 grouped digital inputs
- X2** – OR6: Assembly Group with 6 Output Relays (Changeover / Form C)
- X3** – TIs: Standard phase current measuring card and sensitive ground current measuring
- X4** – TU: Card with 4 voltage transformer measuring inputs (0 ... 800 VAC, under UL: 0 ... 600 VAC)
- X5** – AnO4: Analog Outputs
- X6** – OR6: Assembly Group with 6 Output Relays (Changeover / Form C)
- X102** – Universal Resistance-Temperature Detector (URTD) input, Fiber optics interface, Versatile Link
- X103** – Modbus TCP / IEC 60870-5-104 / DNP3.0 TCP/UDP, Redundant Ethernet interface, 100 Mbit/s, RJ45 (BASE100-FX)
- X104** – IRIG-B00X, incl. System Contact (Supervision Contact)

# MRMV4-2C1BQA

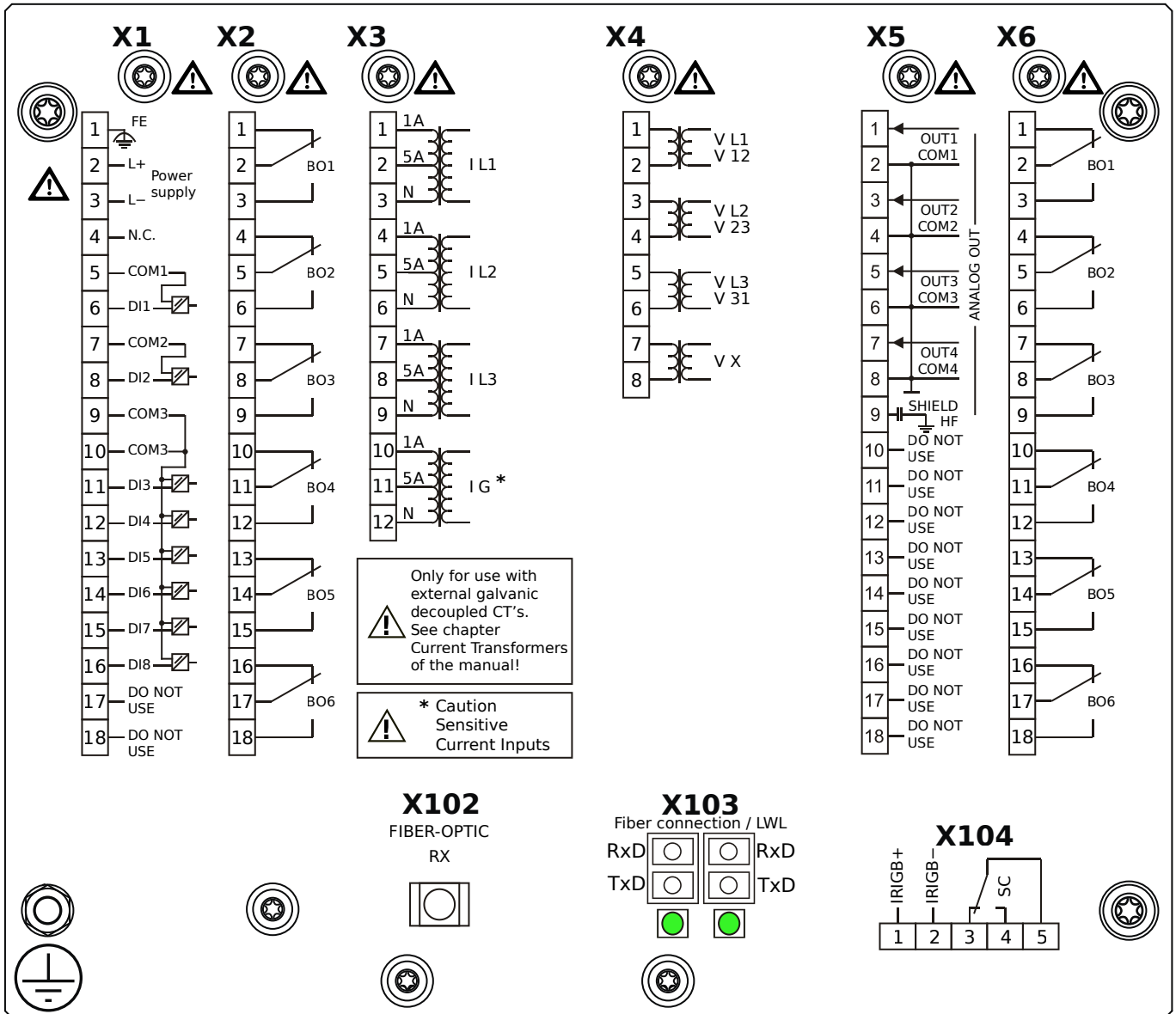

## Housing B2, small display, 19" rack mounting

- X1** – DI8-X1: Wide-range power supply unit, incl. 2 non-grouped digital inputs and 6 grouped digital inputs
- X2** – OR6: Assembly Group with 6 Output Relays (Changeover / Form C)
- X3** – TIs: Standard phase current measuring card and sensitive ground current measuring
- X4** – TU: Card with 4 voltage transformer measuring inputs (0 ... 800 VAC, under UL: 0 ... 600 VAC)
- X5** – AnO4: Analog Outputs
- X6** – OR6: Assembly Group with 6 Output Relays (Changeover / Form C)
- X102** – Universal Resistance-Temperature Detector (URTD) input, Fiber optics interface, Versatile Link
- X103** – IEC 61850 / Modbus TCP / IEC 60870-5-104 / DNP3.0 TCP/UDP, Redundant Fiber optics interface, LC Connector
- X104** – IRIG-B00X, incl. System Contact (Supervision Contact)

# MRMV4-2C1BQB

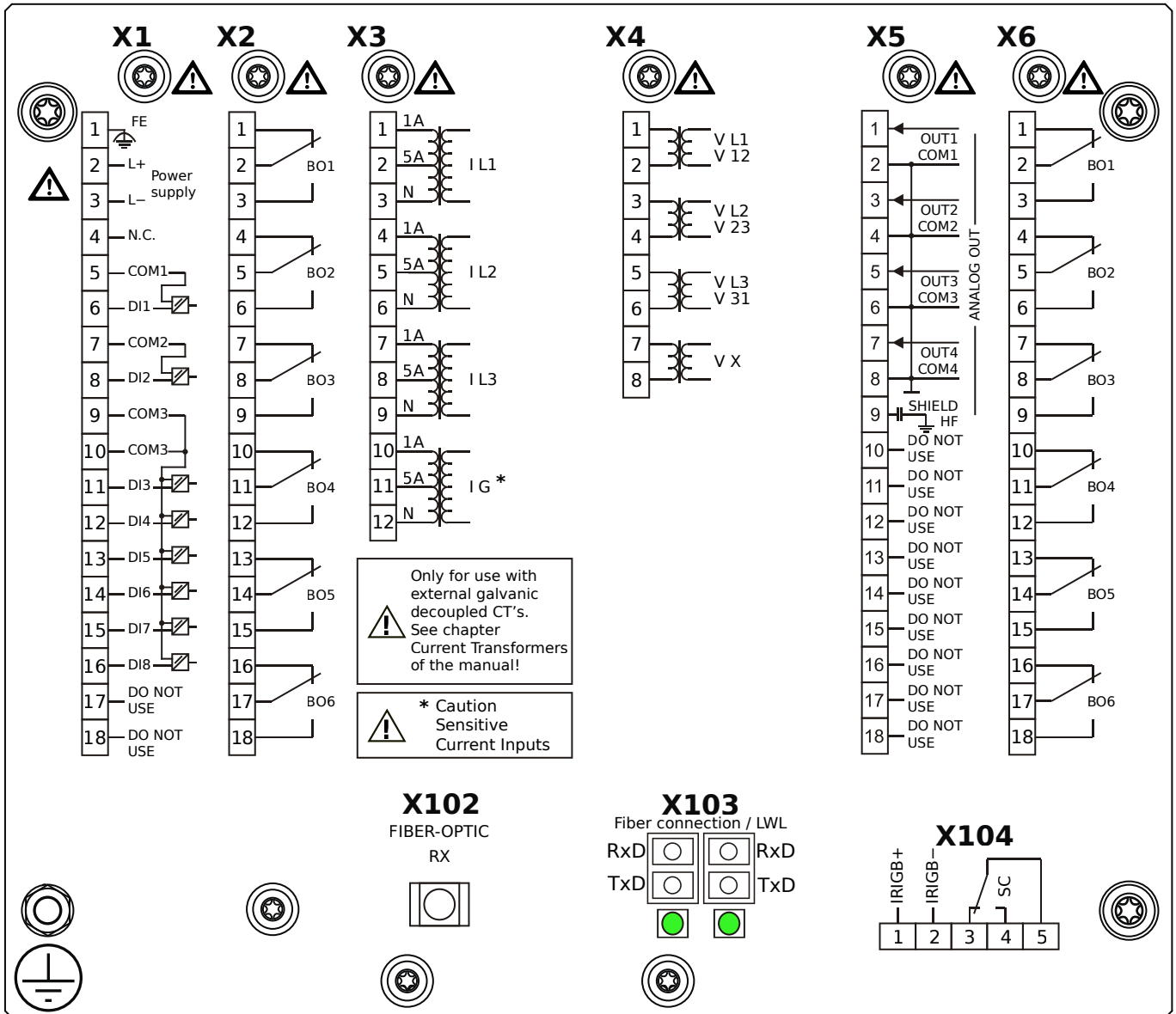

## Housing B2, small display, 19" rack mounting

+ Conformal Coating (for installations in harsh environment)

- X1** – DI8-X1: Wide-range power supply unit, incl. 2 non-grouped digital inputs and 6 grouped digital inputs
- X2** – OR6: Assembly Group with 6 Output Relays (Changeover / Form C)
- X3** – TIs: Standard phase current measuring card and sensitive ground current measuring
- X4** – TU: Card with 4 voltage transformer measuring inputs (0 ... 800 VAC, under UL: 0 ... 600 VAC)
- X5** – AnO4: Analog Outputs
- X6** – OR6: Assembly Group with 6 Output Relays (Changeover / Form C)
- X102** – Universal Resistance-Temperature Detector (URTD) input, Fiber optics interface, Versatile Link
- X103** – IEC 61850 / Modbus TCP / IEC 60870-5-104 / DNP3.0 TCP/UDP, Redundant Fiber optics interface, LC Connector
- X104** – IRIG-B00X, incl. System Contact (Supervision Contact)

# MRMV4-2C1BRA

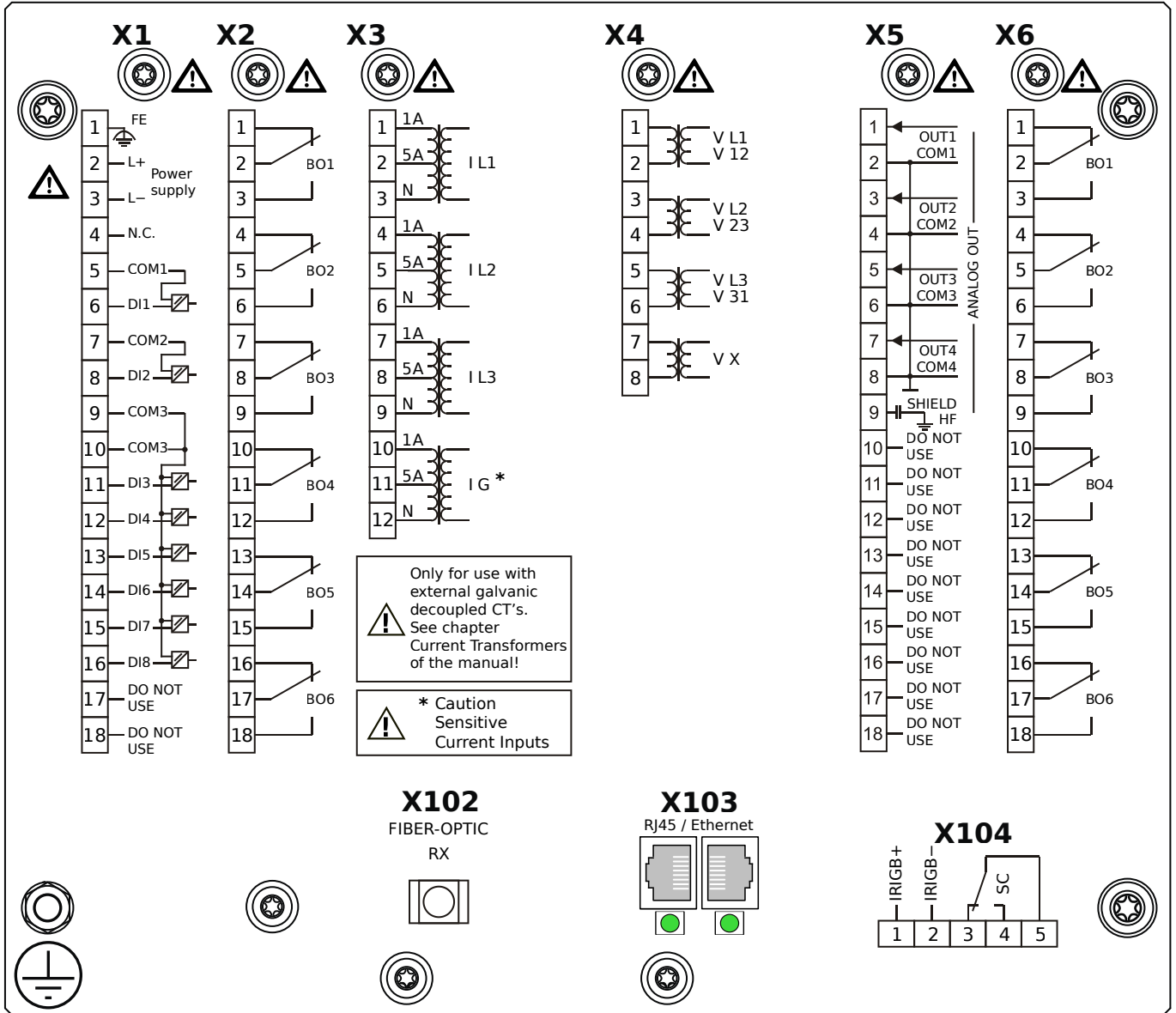

## Housing B2, small display, 19" rack mounting

- X1** – DI8-X1: Wide-range power supply unit, incl. 2 non-grouped digital inputs and 6 grouped digital inputs
- X2** – OR6: Assembly Group with 6 Output Relays (Changeover / Form C)
- X3** – TIs: Standard phase current measuring card and sensitive ground current measuring
- X4** – TU: Card with 4 voltage transformer measuring inputs (0 ... 800 VAC, under UL: 0 ... 600 VAC)
- X5** – AnO4: Analog Outputs
- X6** – OR6: Assembly Group with 6 Output Relays (Changeover / Form C)
- X102** – Universal Resistance-Temperature Detector (URTD) input, Fiber optics interface, Versatile Link
- X103** – IEC 61850 / Modbus TCP / IEC 60870-5-104 / DNP3.0 TCP/UDP, Redundant Ethernet interface, 100 Mbit/s, RJ45
- X104** – IRIG-B00X, incl. System Contact (Supervision Contact)

# MRMV4-2C1BRB

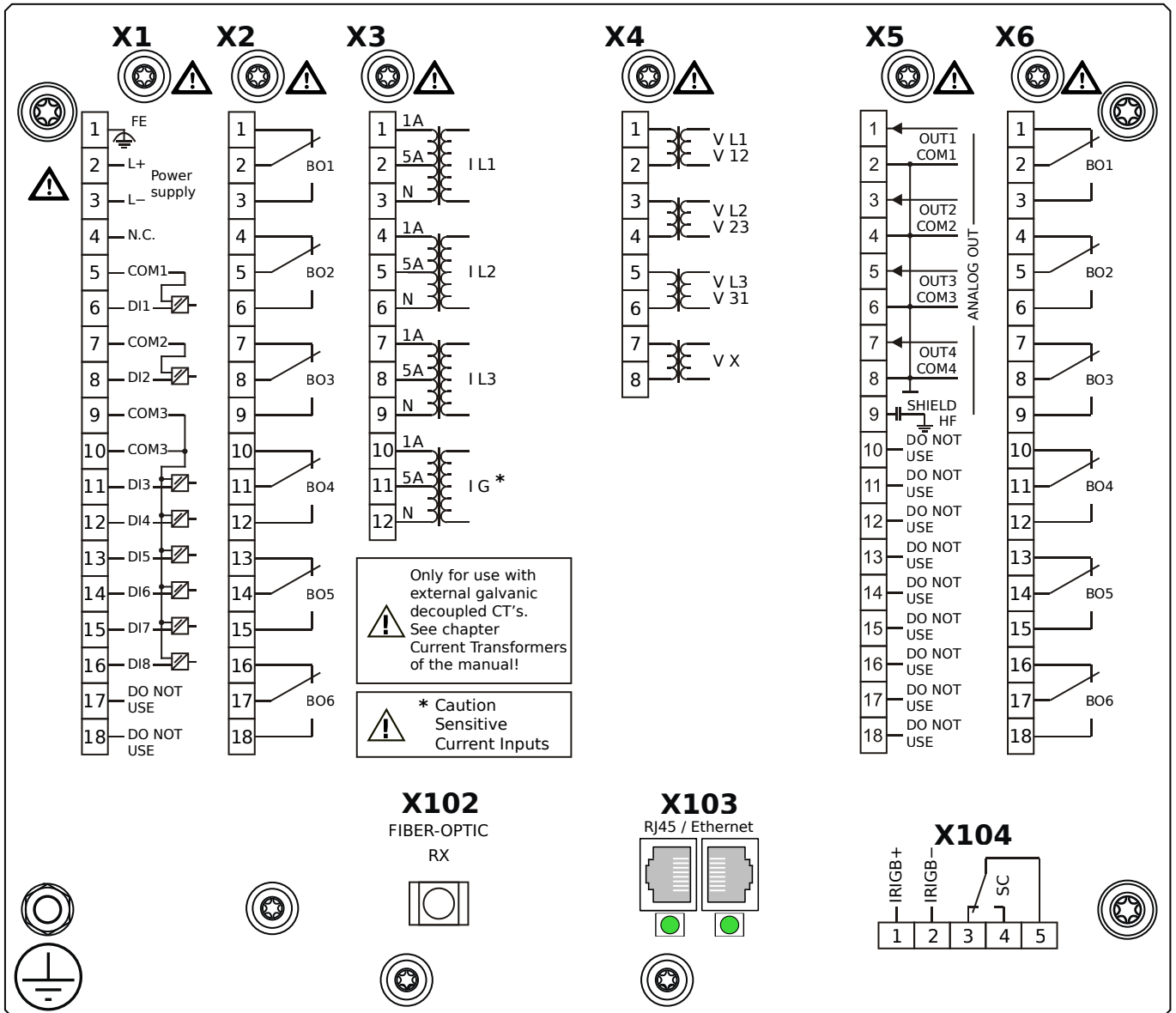

## Housing B2, small display, 19" rack mounting

+ Conformal Coating (for installations in harsh environment)

**X1** – DI8-X1: Wide-range power supply unit, incl. 2 non-grouped digital inputs and 6 grouped digital inputs

**X2** – OR6: Assembly Group with 6 Output Relays (Changeover / Form C)

**X3** – TIs: Standard phase current measuring card and sensitive ground current measuring

**X4** – TU: Card with 4 voltage transformer measuring inputs (0 ... 800 VAC, under UL: 0 ... 600 VAC)

**X5** – AnO4: Analog Outputs

**X6** – OR6: Assembly Group with 6 Output Relays (Changeover / Form C)

**X102** – Universal Resistance-Temperature Detector (URTD) input, Fiber optics interface, Versatile Link

**X103** – IEC 61850 / Modbus TCP / IEC 60870-5-104 / DNP3.0 TCP/UDP, Redundant Ethernet interface, 100 Mbit/s, RJ45

(BASE100-FX)

**X104** – IRIG-B00X, incl. System Contact (Supervision Contact)

# MRMV4-2C1BTA

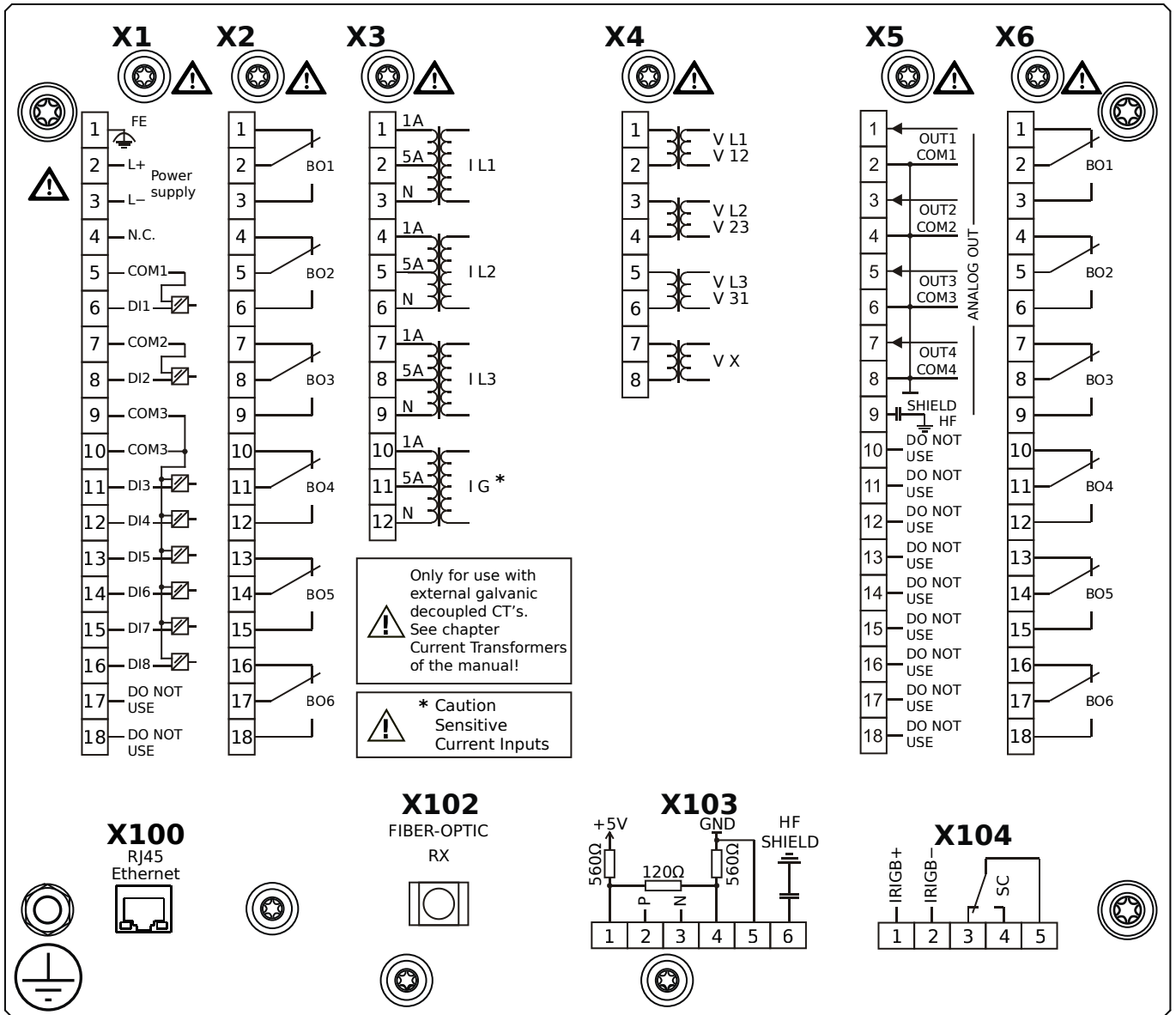

## Housing B2, small display, 19" rack mounting

- X1** – DI8-X1: Wide-range power supply unit, incl. 2 non-grouped digital inputs and 6 grouped digital inputs
- X2** – OR6: Assembly Group with 6 Output Relays (Changeover / Form C)
- X3** – TIs: Standard phase current measuring card and sensitive ground current measuring
- X4** – TU: Card with 4 voltage transformer measuring inputs (0 ... 800 VAC, under UL: 0 ... 600 VAC)
- X5** – AnO4: Analog Outputs
- X6** – OR6: Assembly Group with 6 Output Relays (Changeover / Form C)
- X100** – IEC 61850 / Modbus TCP / IEC 60870-5-104 / DNP3.0 TCP/UDP, Ethernet interface, 100 Mbit/s, RJ45 (BASE100-FX)
- X102** – Universal Resistance-Temperature Detector (URTD) input, Fiber optics interface, Versatile Link
- X103** – IEC 60870-5-103 / Modbus RTU / DNP3.0 RTU, RS485, Terminals
- X104** – IRIG-B00X, incl. System Contact (Supervision Contact)



# MRMV4-2C1BTB

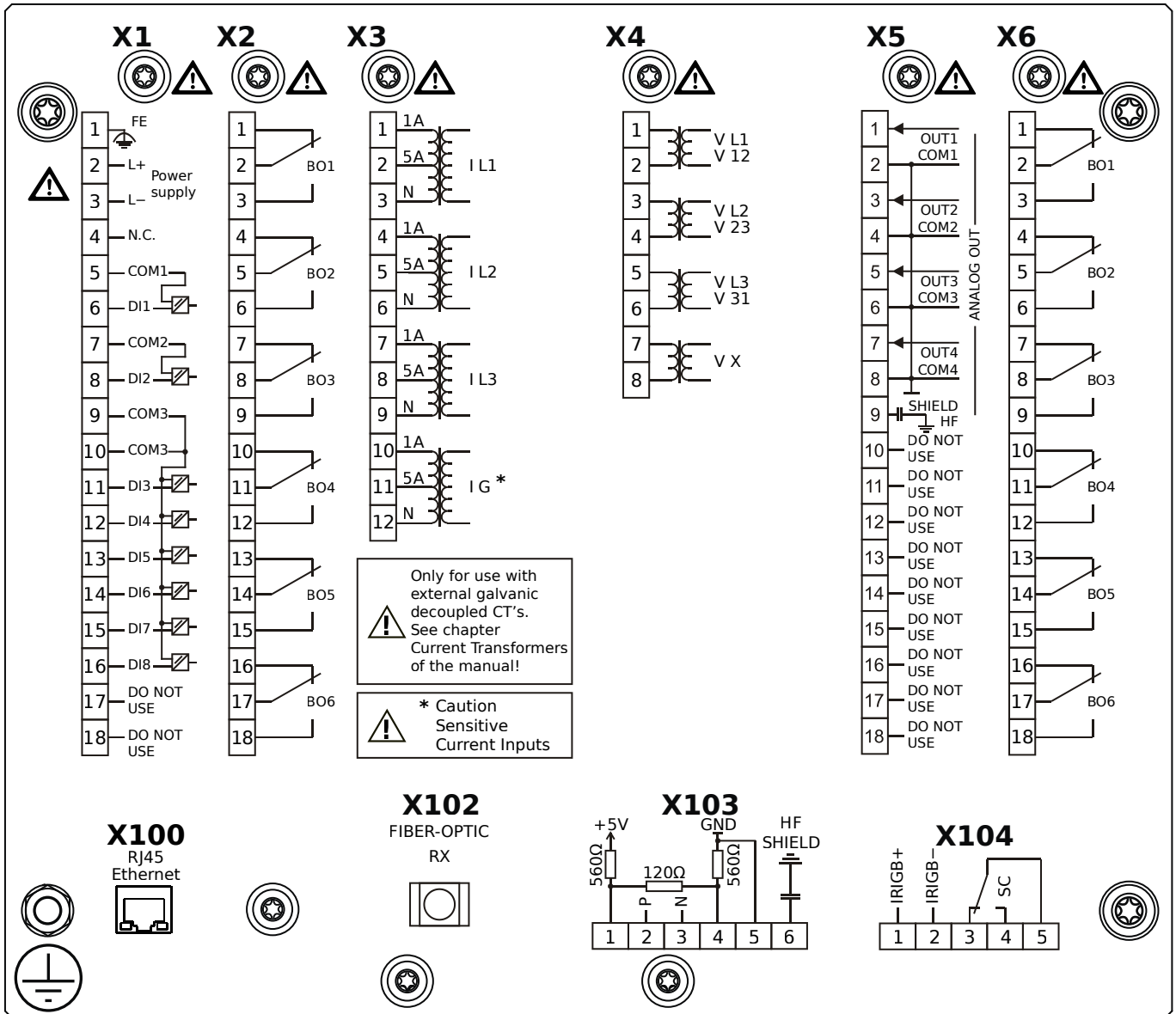

## Housing B2, small display, 19" rack mounting

+ Conformal Coating (for installations in harsh environment)

**X1** – DI8-X1: Wide-range power supply unit, incl. 2 non-grouped digital inputs and 6 grouped digital inputs

**X2** – OR6: Assembly Group with 6 Output Relays (Changeover / Form C)

**X3** – TIs: Standard phase current measuring card and sensitive ground current measuring

**X4** – TU: Card with 4 voltage transformer measuring inputs (0 ... 800 VAC, under UL: 0 ... 600 VAC)

**X5** – AnO4: Analog Outputs

**X6** – OR6: Assembly Group with 6 Output Relays (Changeover / Form C)

**X100** – IEC 61850 / Modbus TCP / IEC 60870-5-104 / DNP3.0 TCP/UDP, Ethernet interface, 100 Mbit/s, RJ45 (BASE100-

FX)

**X102** – Universal Resistance-Temperature Detector (URTD) input, Fiber optics interface, Versatile Link

**X103** – IEC 60870-5-103 / Modbus RTU / DNP3.0 RTU, RS485, Terminals

**X104** – IRIG-B00X, incl. System Contact (Supervision Contact)

## Appendix – Legend

In this legend designations of various device types are listed, e.g. transformer protection, motor protection, generator protection, etc. Therefore it can occur that not every designation actually appears on the wiring diagram of your device.

<b>PE</b>	– Connection of protective earth (see chapter Grounding in the Technical Manual).
<b>FE</b>	– Connection of functional earth (see chapter Grounding in the Technical Manual).
<b>Power Supply</b>	– Connection for auxiliary power supply.
<b>IL1</b>	– Phase current input L1 (in some countries designated as IA).
<b>IL2</b>	– Phase current input L2 (in some countries designated as IB).
<b>IL3</b>	– Phase current input L3 (in some countries designated as IC).
<b>ILx C–D</b>	– WIC1 Test windings.
<b>ILx S1–S2</b>	– WIC1 phase current inputs.
<b>IL1 W1 ... IL3 W1</b>	– Phase current input L1...L3, winding side 1.
<b>IL1 W2 ... IL3 W2</b>	– Phase current input L1...L3, winding side 2.
<b>IG</b>	– Ground (earth) current input.
<b>IG W1, IG W2</b>	– Ground (earth) current input, winding side 1 / 2.
<b>VL1</b>	– Phase-to-neutral voltage L1 (in some countries designated as VA).
<b>VL2</b>	– Phase-to-neutral voltage L2 (in some countries designated as VB).
<b>VL3</b>	– Phase-to-neutral voltage L3 (in some countries designated as VC).
<b>VL12</b>	– Phase-to-phase voltage V12 (in some countries designated as VAB).
<b>VL23</b>	– Phase-to-phase voltage V23 (in some countries designated as VBC).
<b>VL31</b>	– Phase-to-phase voltage V31 (in some countries designated as VCA).
<b>VX</b>	– 4th voltage measuring input for measuring residual voltage or synchro-check.
<b>BO</b>	– Binary output relay.
<b>NO / NC</b>	– Contact output, normally open (Form A) / closed (Form B).
<b>DI</b>	– Digital input.
<b>COM</b>	– Common connection of digital inputs.
<b>Out+, AnOut</b>	– Analog output + (0/4...20 mA or 0...10 V).
<b>In–, AnIn</b>	– Analog input + (0/4...20 mA or 0...10 V).
<b>n.c.</b>	– Not connected.
<b>DO NOT USE</b>	– Do not use. (Caution: Non-usable internal wiring may exist.)
<b>SC</b>	– Self-supervision contact.
<b>HF SHIELD</b>	– Connection cable shield.
<b>Fiber Optics / LWL</b>	– Fiber optic connection.

# High **PROTEC**

## MRMV4

### WIRING DIAGRAMS

