

WIRING DIAGRAMS

High **PROTEC** | PROTECTION TECHNOLOGY
MADE SIMPLE

MRA4 | Directional Feeder Protection

Version: 3.10

Original document

English

This document does not replace the Technical Manual.

MRA4-2A0AAA

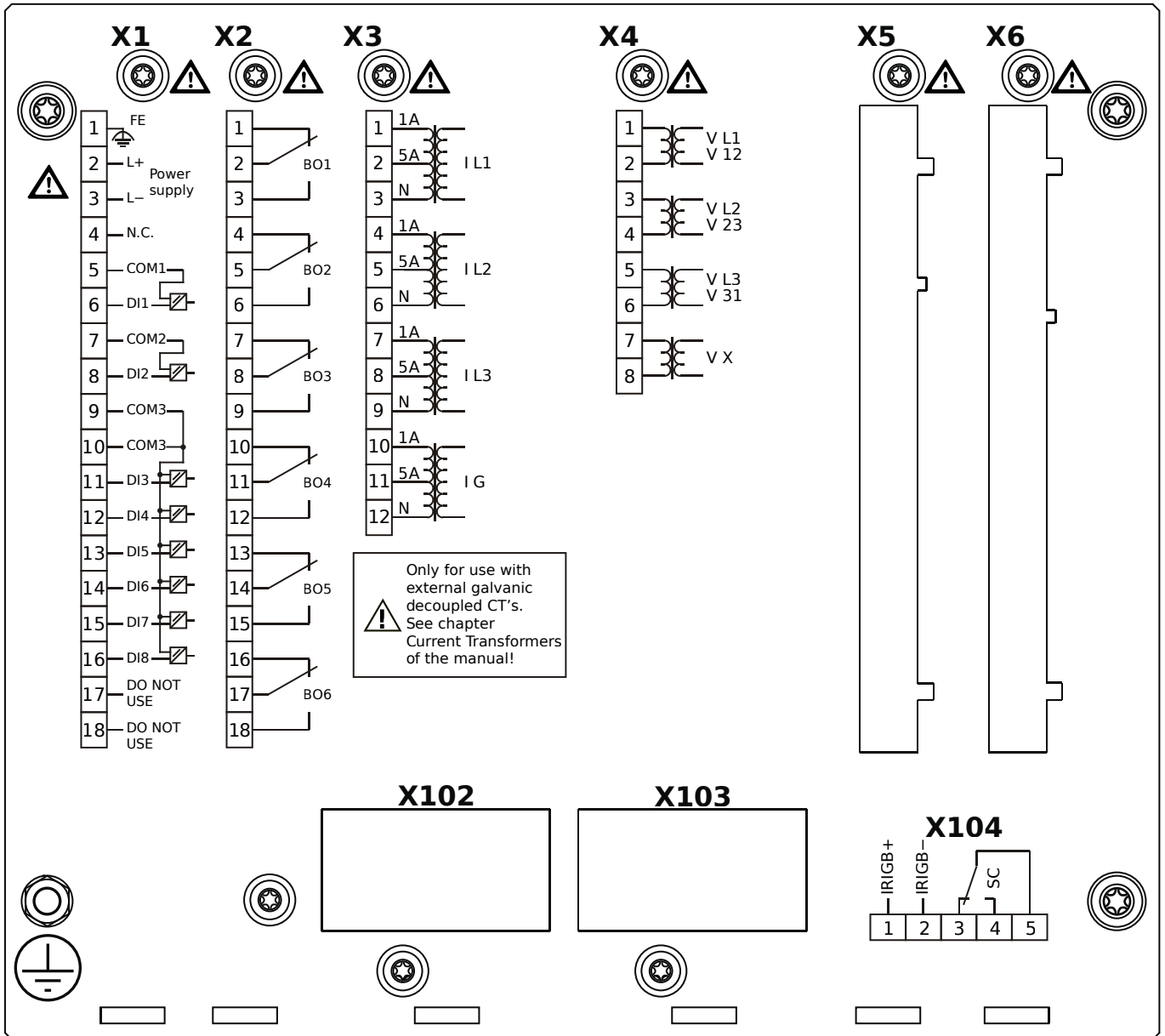

Housing B2, small display, door mounting

- X1** – DI8-X1: Wide-range power supply unit, incl. 2 non-grouped digital inputs and 6 grouped digital inputs
- X2** – OR6: Assembly Group with 6 Output Relays (Changeover / Form C)
- X3** – TI: Standard current measuring card
- X4** – TU: Card with 4 voltage transformer measuring inputs (0 ... 800 VAC, under UL: 0 ... 600 VAC)
- X104** – IRIG-B00X, incl. System Contact (Supervision Contact)

MRA4-2A0AAB

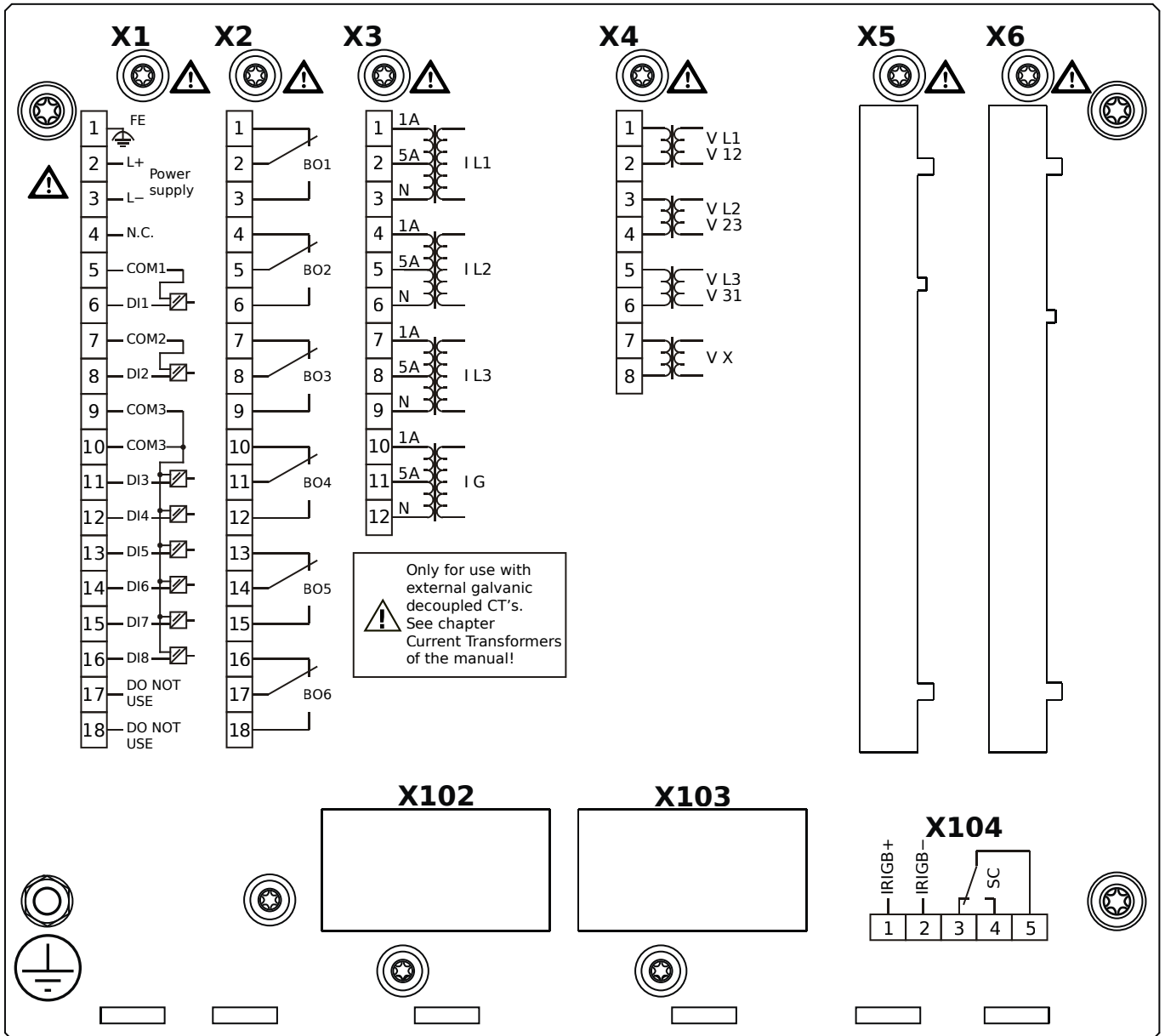

Housing B2, small display, door mounting

+ Conformal Coating (for installations in harsh environment)

- X1** – DI8-X1: Wide-range power supply unit, incl. 2 non-grouped digital inputs and 6 grouped digital inputs
- X2** – OR6: Assembly Group with 6 Output Relays (Changeover / Form C)
- X3** – TI: Standard current measuring card
- X4** – TU: Card with 4 voltage transformer measuring inputs (0 ... 800 VAC, under UL: 0 ... 600 VAC)
- X104** – IRIG-B00X, incl. System Contact (Supervision Contact)

MRA4-2A0ABA

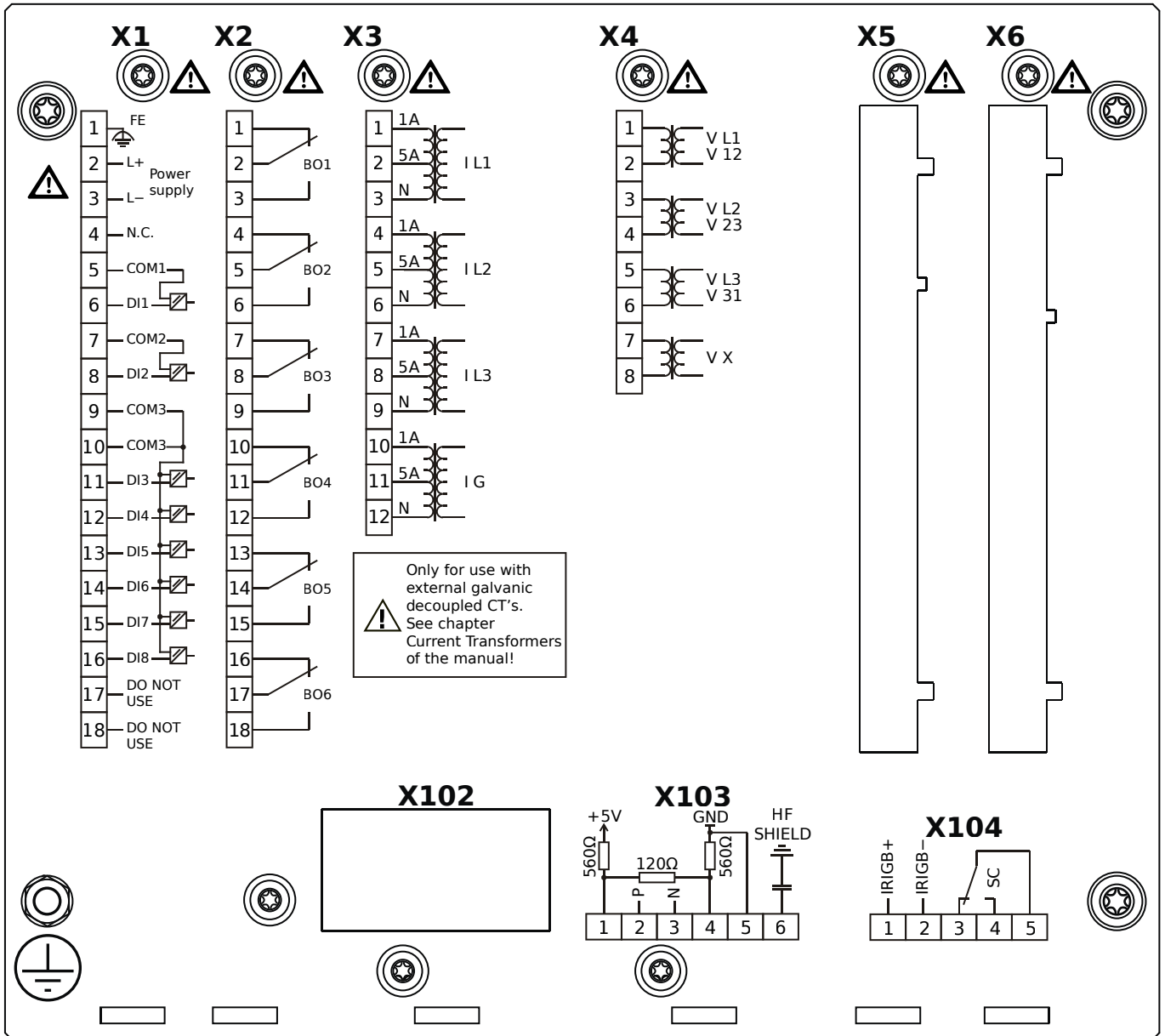

Housing B2, small display, door mounting

- X1** – DI8-X1: Wide-range power supply unit, incl. 2 non-grouped digital inputs and 6 grouped digital inputs
- X2** – OR6: Assembly Group with 6 Output Relays (Changeover / Form C)
- X3** – TI: Standard current measuring card
- X4** – TU: Card with 4 voltage transformer measuring inputs (0 ... 800 VAC, under UL: 0 ... 600 VAC)
- X103** – Modbus RTU / IEC 60870-5-103 / DNP3.0 RTU, RS485, Terminals
- X104** – IRIG-B00X, incl. System Contact (Supervision Contact)

MRA4-2A0ABB

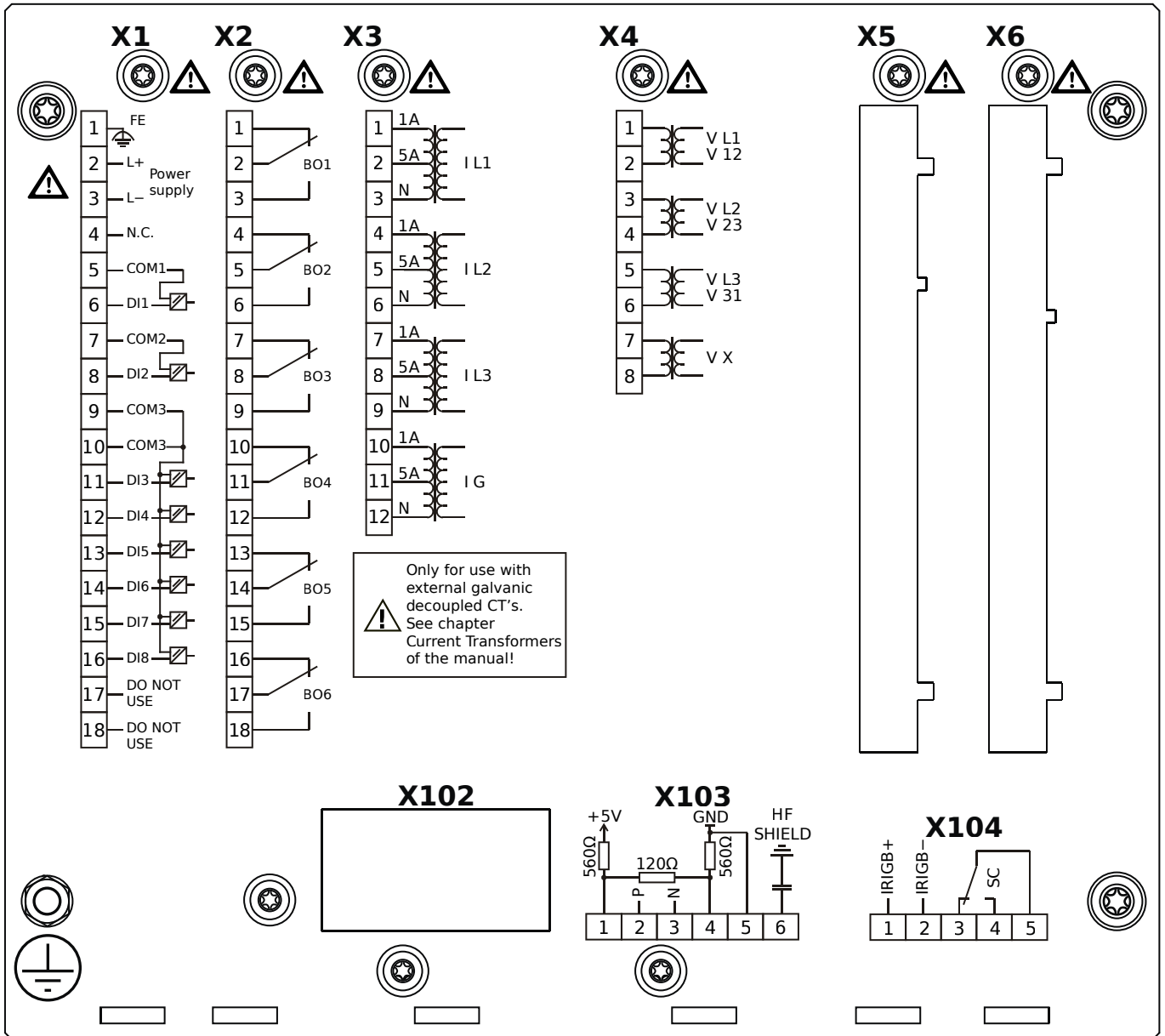

Housing B2, small display, door mounting

+ Conformal Coating (for installations in harsh environment)

- X1** – DI8-X1: Wide-range power supply unit, incl. 2 non-grouped digital inputs and 6 grouped digital inputs
- X2** – OR6: Assembly Group with 6 Output Relays (Changeover / Form C)
- X3** – TI: Standard current measuring card
- X4** – TU: Card with 4 voltage transformer measuring inputs (0 ... 800 VAC, under UL: 0 ... 600 VAC)
- X103** – Modbus RTU / IEC 60870-5-103 / DNP3.0 RTU, RS485, Terminals
- X104** – IRIG-B00X, incl. System Contact (Supervision Contact)

MRA4-2A0ACA

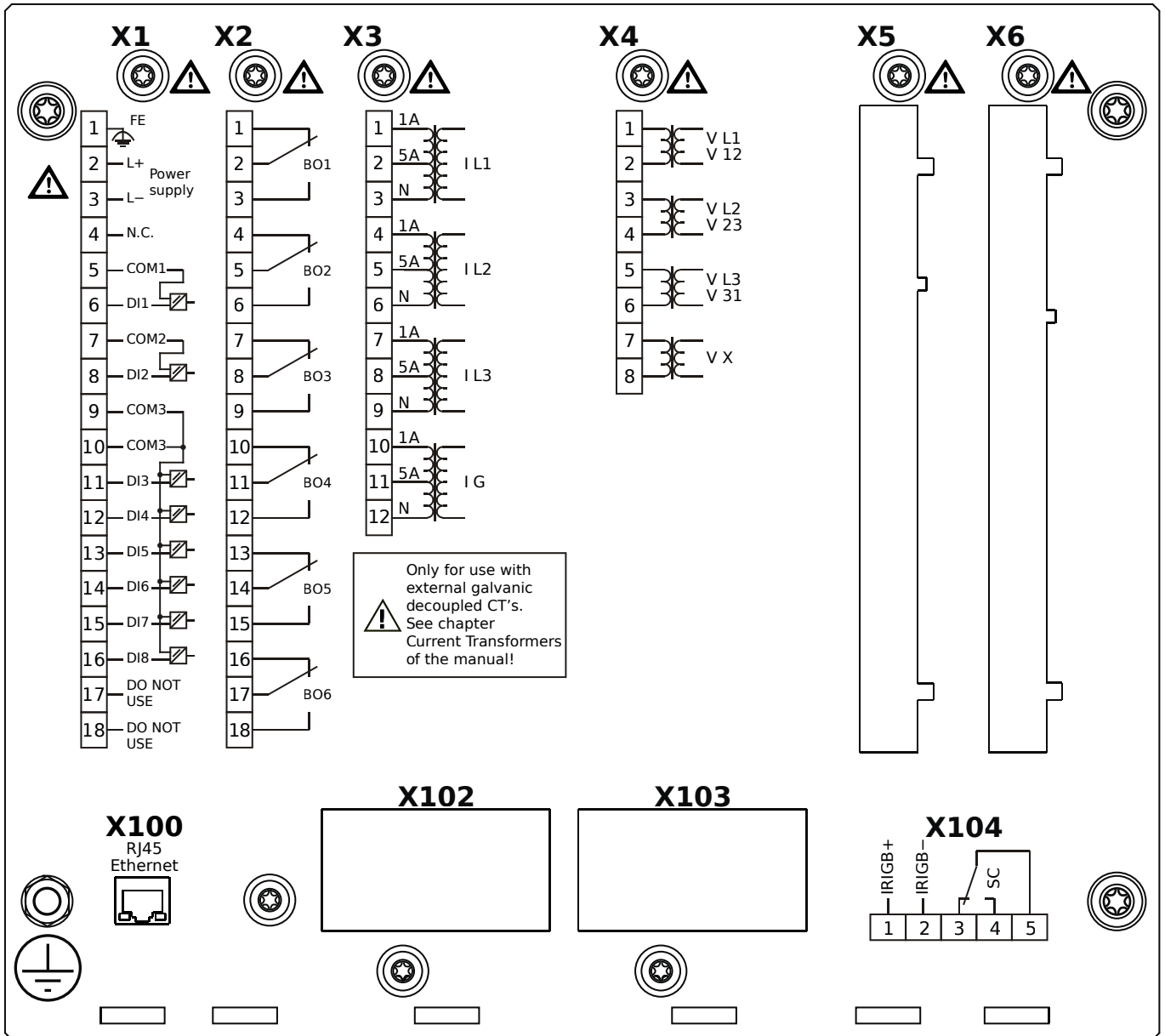

Housing B2, small display, door mounting

- X1** – DI8-X1: Wide-range power supply unit, incl. 2 non-grouped digital inputs and 6 grouped digital inputs
- X2** – OR6: Assembly Group with 6 Output Relays (Changeover / Form C)
- X3** – TI: Standard current measuring card
- X4** – TU: Card with 4 voltage transformer measuring inputs (0 ... 800 VAC, under UL: 0 ... 600 VAC)
- X100** – Modbus TCP / DNP3.0 TCP/UDP, Ethernet interface, 100 Mbit/s, RJ45 (BASE100-FX)
- X104** – IRIG-B00X, incl. System Contact (Supervision Contact)

MRA4-2A0ACB

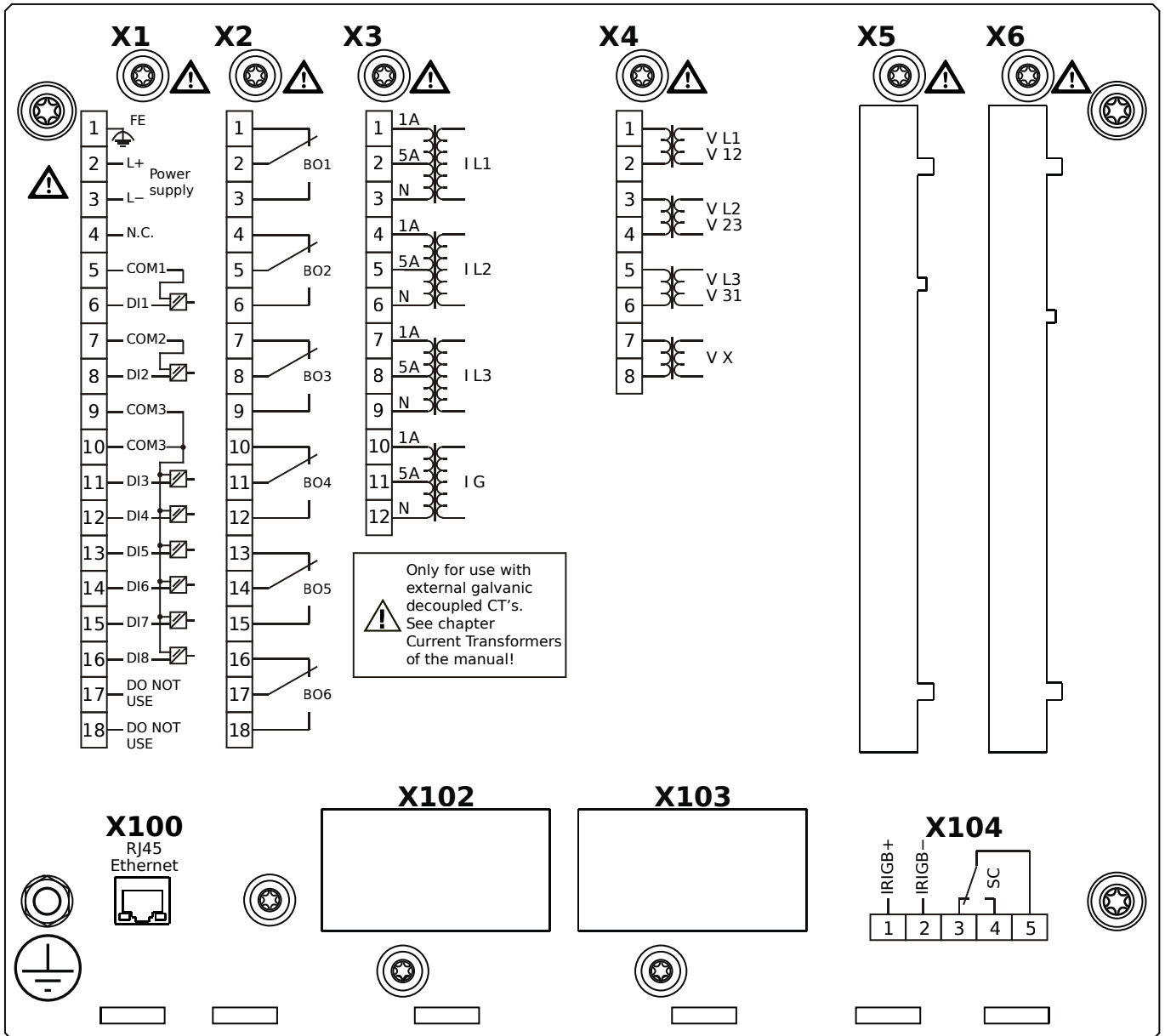

Housing B2, small display, door mounting

+ Conformal Coating (for installations in harsh environment)

- X1** – DI8-X1: Wide-range power supply unit, incl. 2 non-grouped digital inputs and 6 grouped digital inputs
- X2** – OR6: Assembly Group with 6 Output Relays (Changeover / Form C)
- X3** – TI: Standard current measuring card
- X4** – TU: Card with 4 voltage transformer measuring inputs (0 ... 800 VAC, under UL: 0 ... 600 VAC)
- X100** – Modbus TCP / DNP3.0 TCP/UDP, Ethernet interface, 100 Mbit/s, RJ45 (BASE100-FX)
- X104** – IRIG-B00X, incl. System Contact (Supervision Contact)

MRA4-2A0ADA

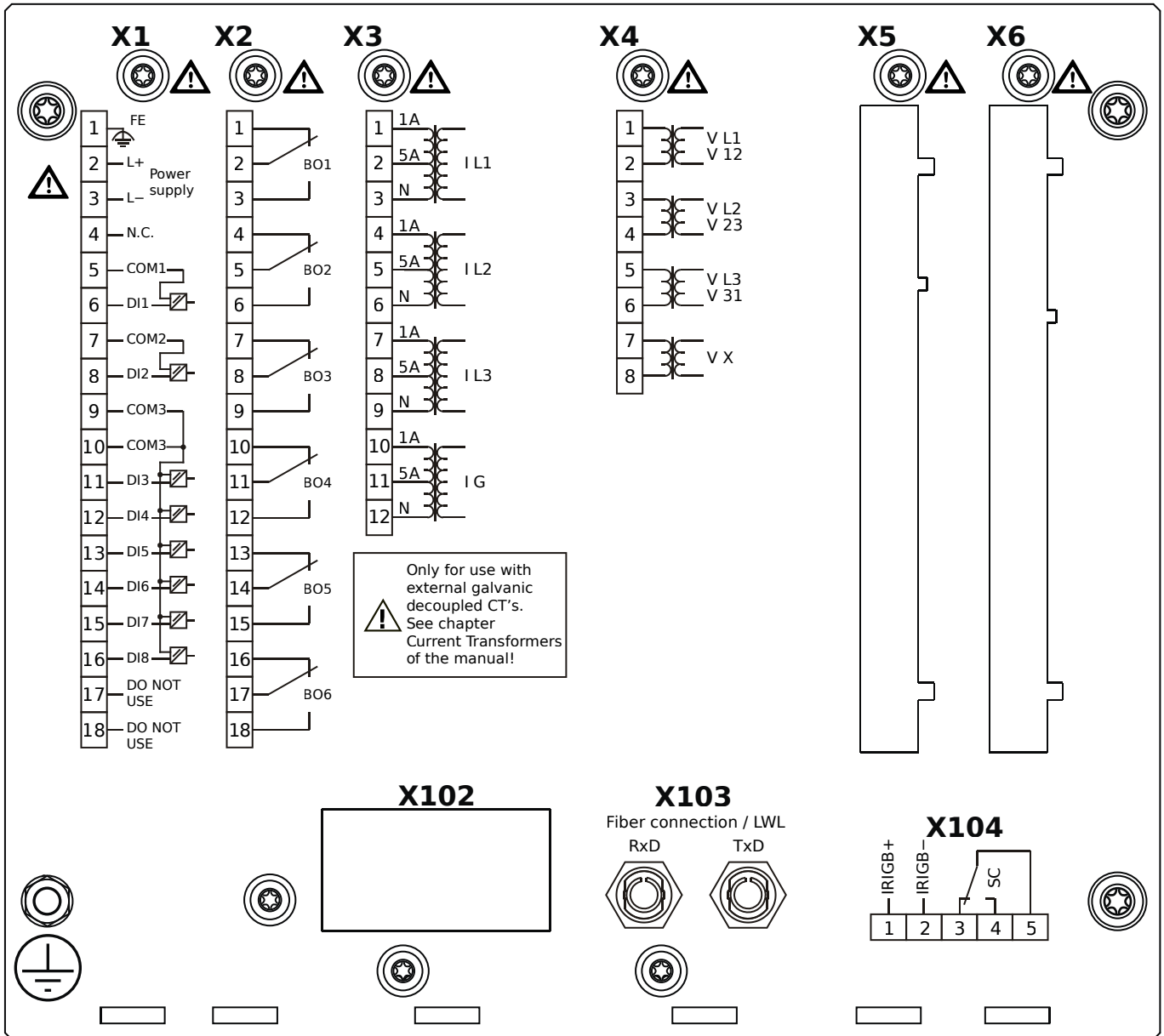

Housing B2, small display, door mounting

- X1** – DI8-X1: Wide-range power supply unit, incl. 2 non-grouped digital inputs and 6 grouped digital inputs
- X2** – OR6: Assembly Group with 6 Output Relays (Changeover / Form C)
- X3** – TI: Standard current measuring card
- X4** – TU: Card with 4 voltage transformer measuring inputs (0 ... 800 VAC, under UL: 0 ... 600 VAC)
- X103** – Profibus-DP, Fiber optics interface, ST Connector
- X104** – IRIG-B00X, incl. System Contact (Supervision Contact)

MRA4-2A0ADB

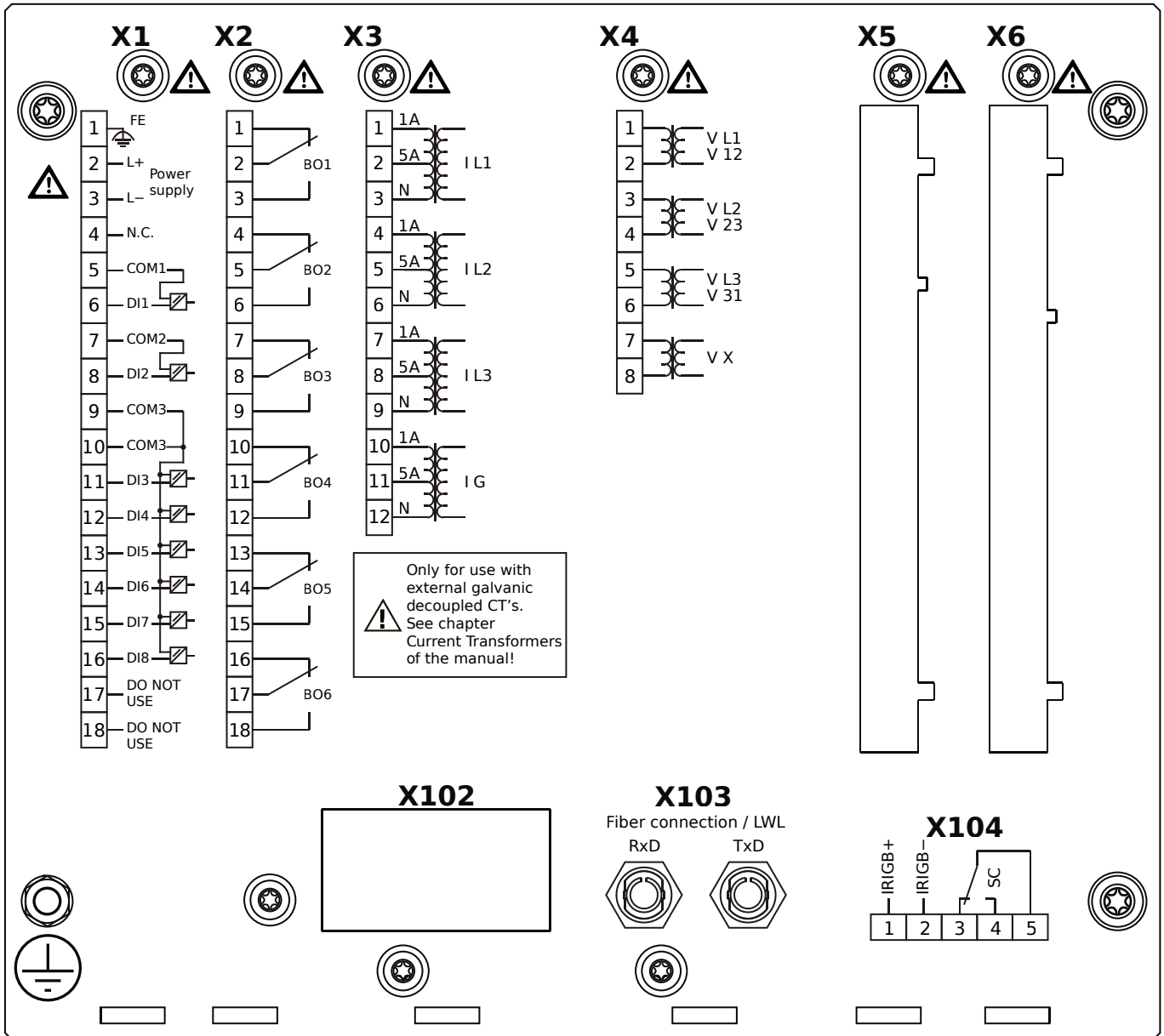

Housing B2, small display, door mounting

+ Conformal Coating (for installations in harsh environment)

- X1** – DI8-X1: Wide-range power supply unit, incl. 2 non-grouped digital inputs and 6 grouped digital inputs
- X2** – OR6: Assembly Group with 6 Output Relays (Changeover / Form C)
- X3** – TI: Standard current measuring card
- X4** – TU: Card with 4 voltage transformer measuring inputs (0 ... 800 VAC, under UL: 0 ... 600 VAC)
- X103** – Profibus-DP, Fiber optics interface, ST Connector
- X104** – IRIG-B00X, incl. System Contact (Supervision Contact)

MRA4-2A0AEA

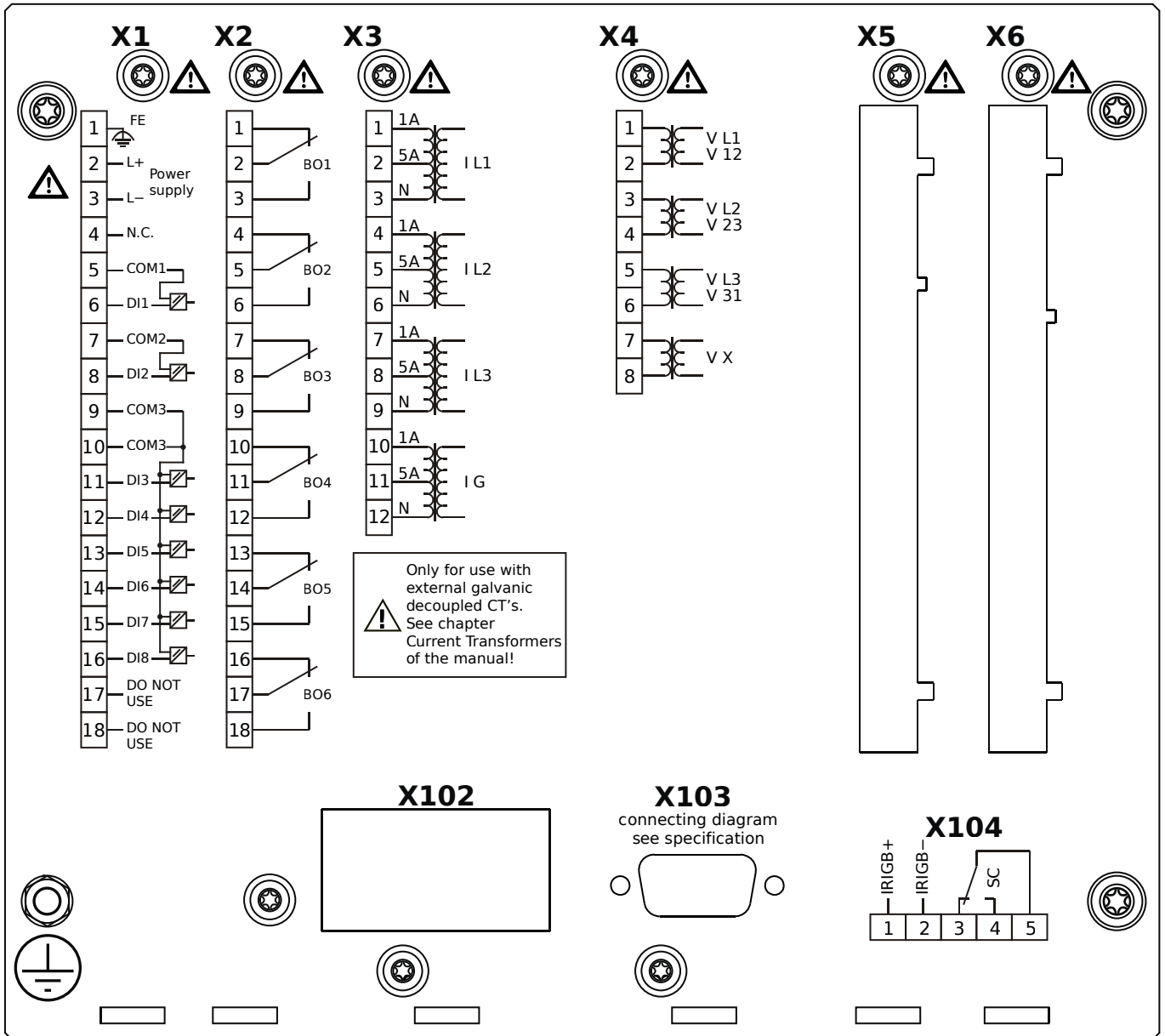

Housing B2, small display, door mounting

- X1** – DI8-X1: Wide-range power supply unit, incl. 2 non-grouped digital inputs and 6 grouped digital inputs
- X2** – OR6: Assembly Group with 6 Output Relays (Changeover / Form C)
- X3** – TI: Standard current measuring card
- X4** – TU: Card with 4 voltage transformer measuring inputs (0 ... 800 VAC, under UL: 0 ... 600 VAC)
- X103** – Profibus-DP, RS485, D-SUB
- X104** – IRIG-B00X, incl. System Contact (Supervision Contact)

MRA4-2A0AEB

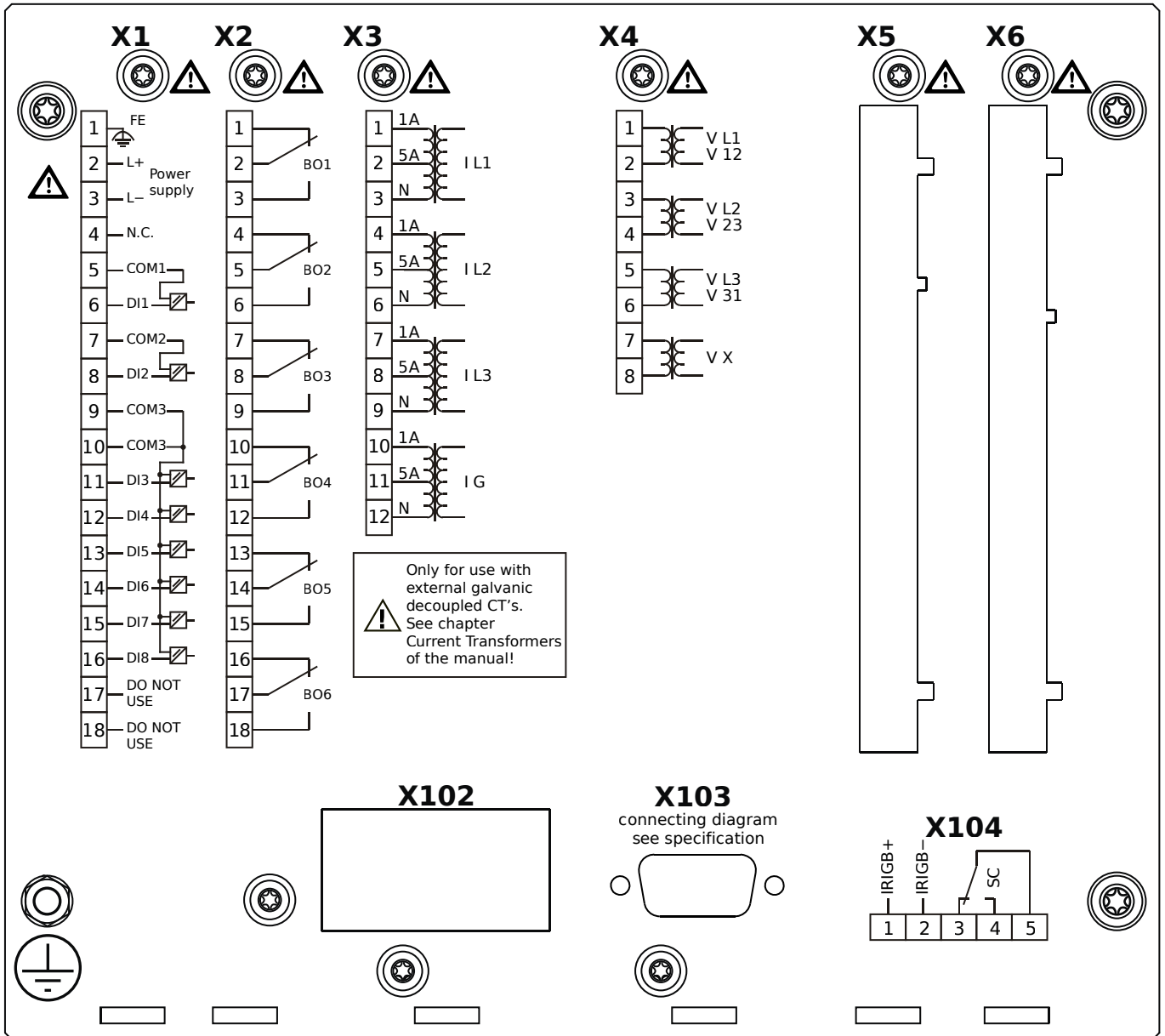

Housing B2, small display, door mounting

+ Conformal Coating (for installations in harsh environment)

- X1** – DI8-X1: Wide-range power supply unit, incl. 2 non-grouped digital inputs and 6 grouped digital inputs
- X2** – OR6: Assembly Group with 6 Output Relays (Changeover / Form C)
- X3** – TI: Standard current measuring card
- X4** – TU: Card with 4 voltage transformer measuring inputs (0 ... 800 VAC, under UL: 0 ... 600 VAC)
- X103** – Profibus-DP, RS485, D-SUB
- X104** – IRIG-B00X, incl. System Contact (Supervision Contact)

MRA4-2A0AFA

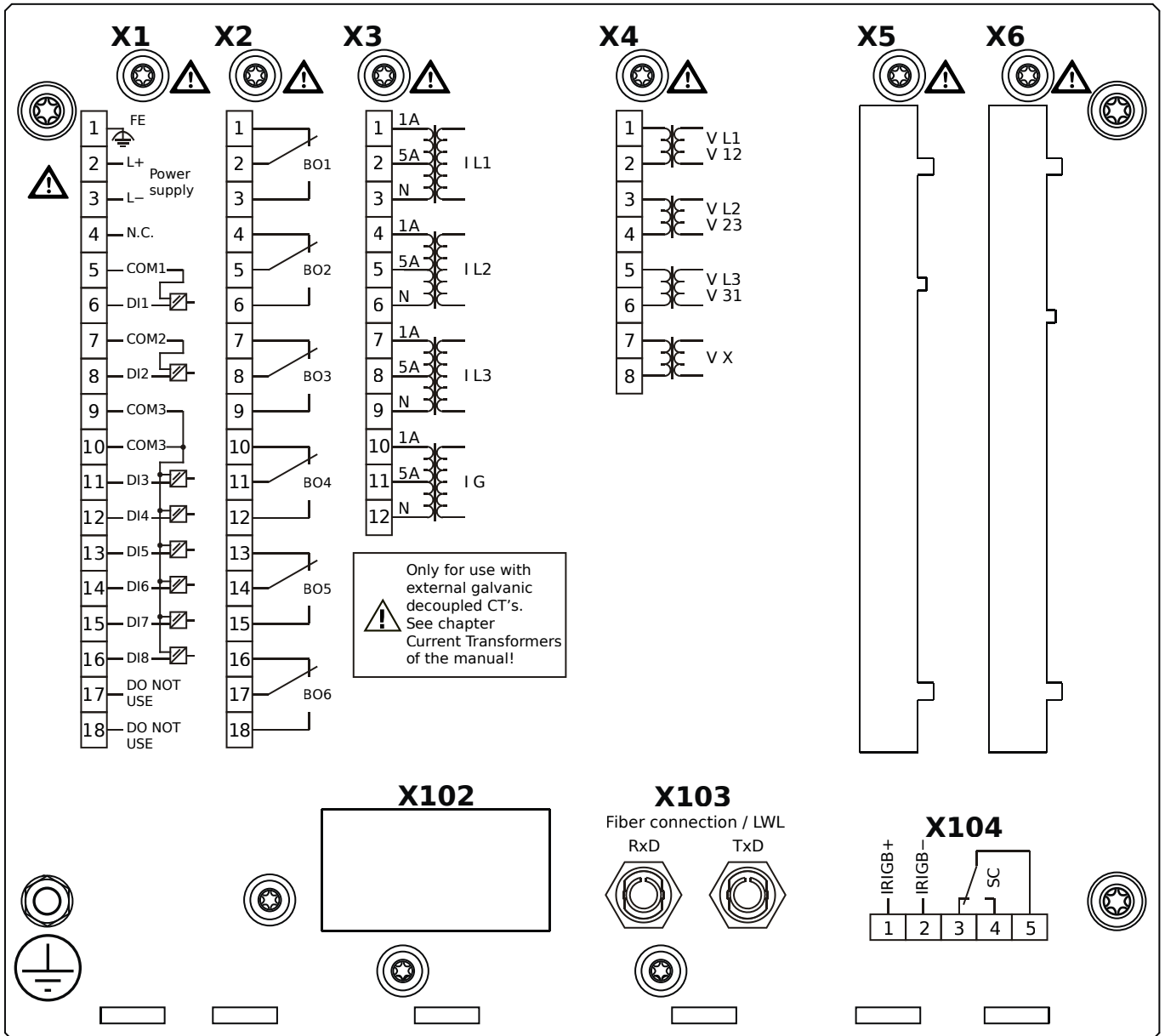

Housing B2, small display, door mounting

- X1** – DI8-X1: Wide-range power supply unit, incl. 2 non-grouped digital inputs and 6 grouped digital inputs
- X2** – OR6: Assembly Group with 6 Output Relays (Changeover / Form C)
- X3** – TI: Standard current measuring card
- X4** – TU: Card with 4 voltage transformer measuring inputs (0 ... 800 VAC, under UL: 0 ... 600 VAC)
- X103** – Modbus RTU / IEC 60870-5-103 / DNP3.0 RTU, Fiber optics interface, ST Connector
- X104** – IRIG-B00X, incl. System Contact (Supervision Contact)

MRA4-2A0AFB

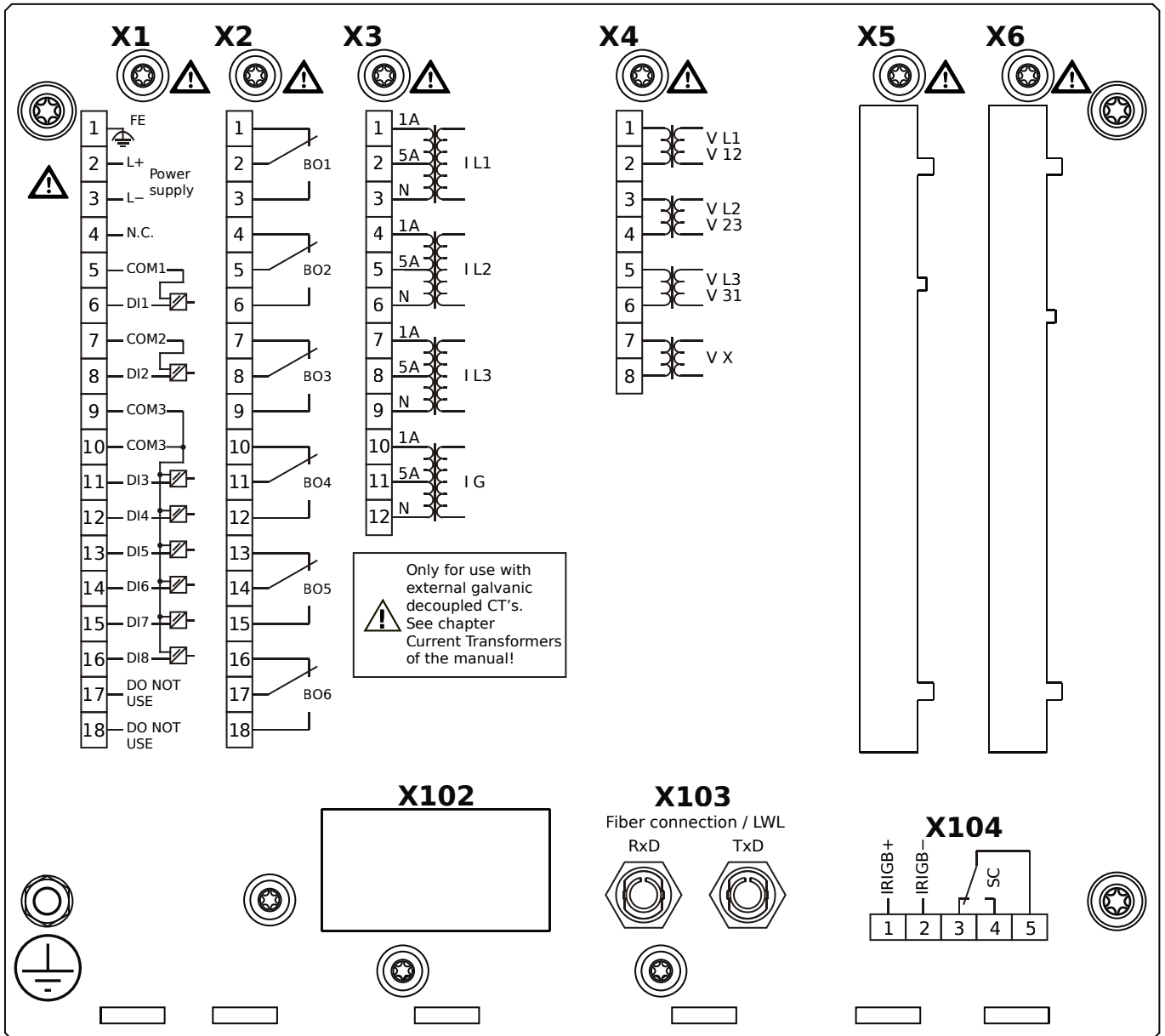

Housing B2, small display, door mounting

+ Conformal Coating (for installations in harsh environment)

- X1** – DI8-X1: Wide-range power supply unit, incl. 2 non-grouped digital inputs and 6 grouped digital inputs
- X2** – OR6: Assembly Group with 6 Output Relays (Changeover / Form C)
- X3** – TI: Standard current measuring card
- X4** – TU: Card with 4 voltage transformer measuring inputs (0 ... 800 VAC, under UL: 0 ... 600 VAC)
- X103** – Modbus RTU / IEC 60870-5-103 / DNP3.0 RTU, Fiber optics interface, ST Connector
- X104** – IRIG-B00X, incl. System Contact (Supervision Contact)

MRA4-2A0AGA

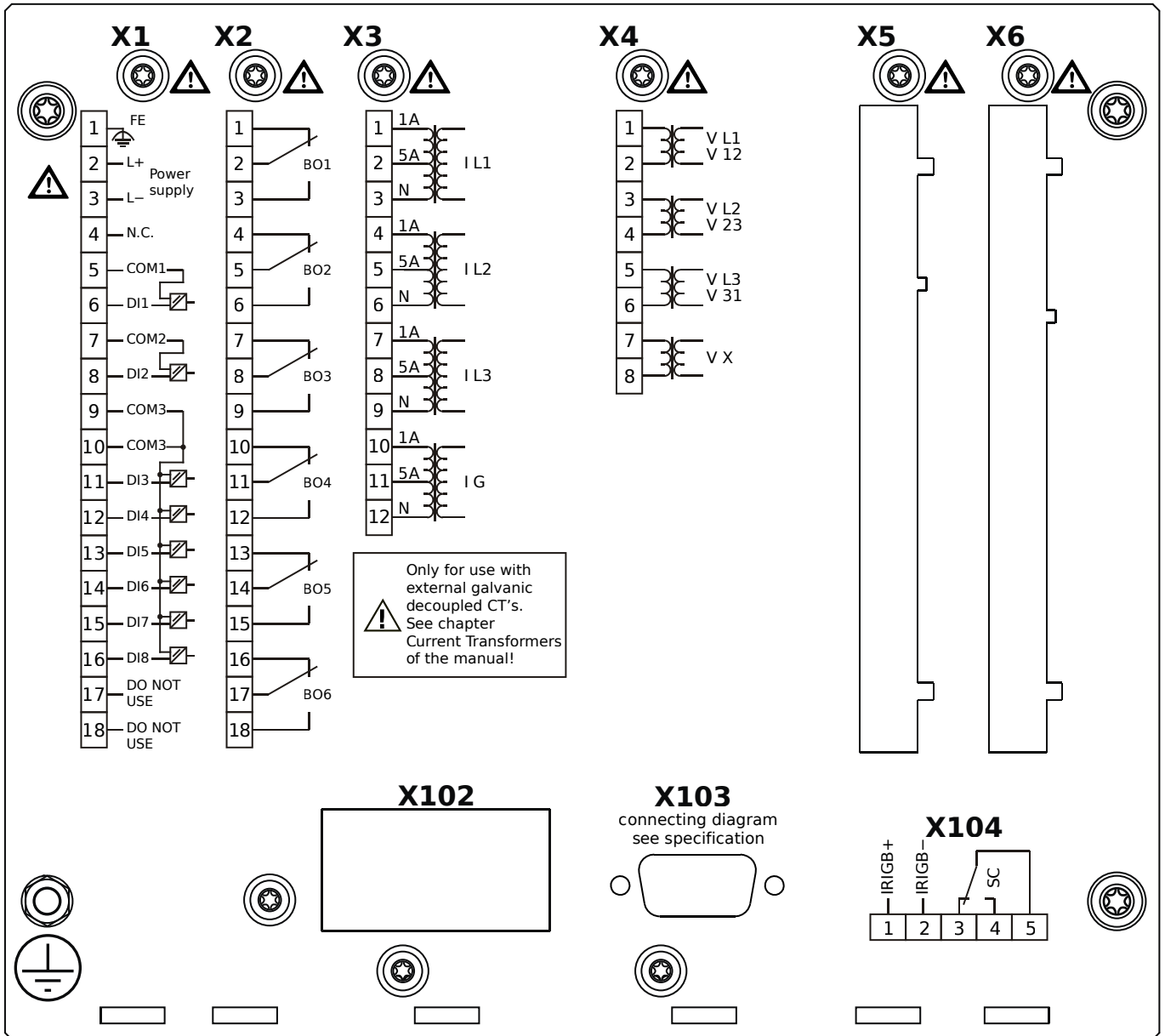

Housing B2, small display, door mounting

- X1** – DI8-X1: Wide-range power supply unit, incl. 2 non-grouped digital inputs and 6 grouped digital inputs
- X2** – OR6: Assembly Group with 6 Output Relays (Changeover / Form C)
- X3** – TI: Standard current measuring card
- X4** – TU: Card with 4 voltage transformer measuring inputs (0 ... 800 VAC, under UL: 0 ... 600 VAC)
- X103** – Modbus RTU / IEC 60870-5-103 / DNP3.0 RTU, RS485, D-SUB
- X104** – IRIG-B00X, incl. System Contact (Supervision Contact)

MRA4-2A0AGB

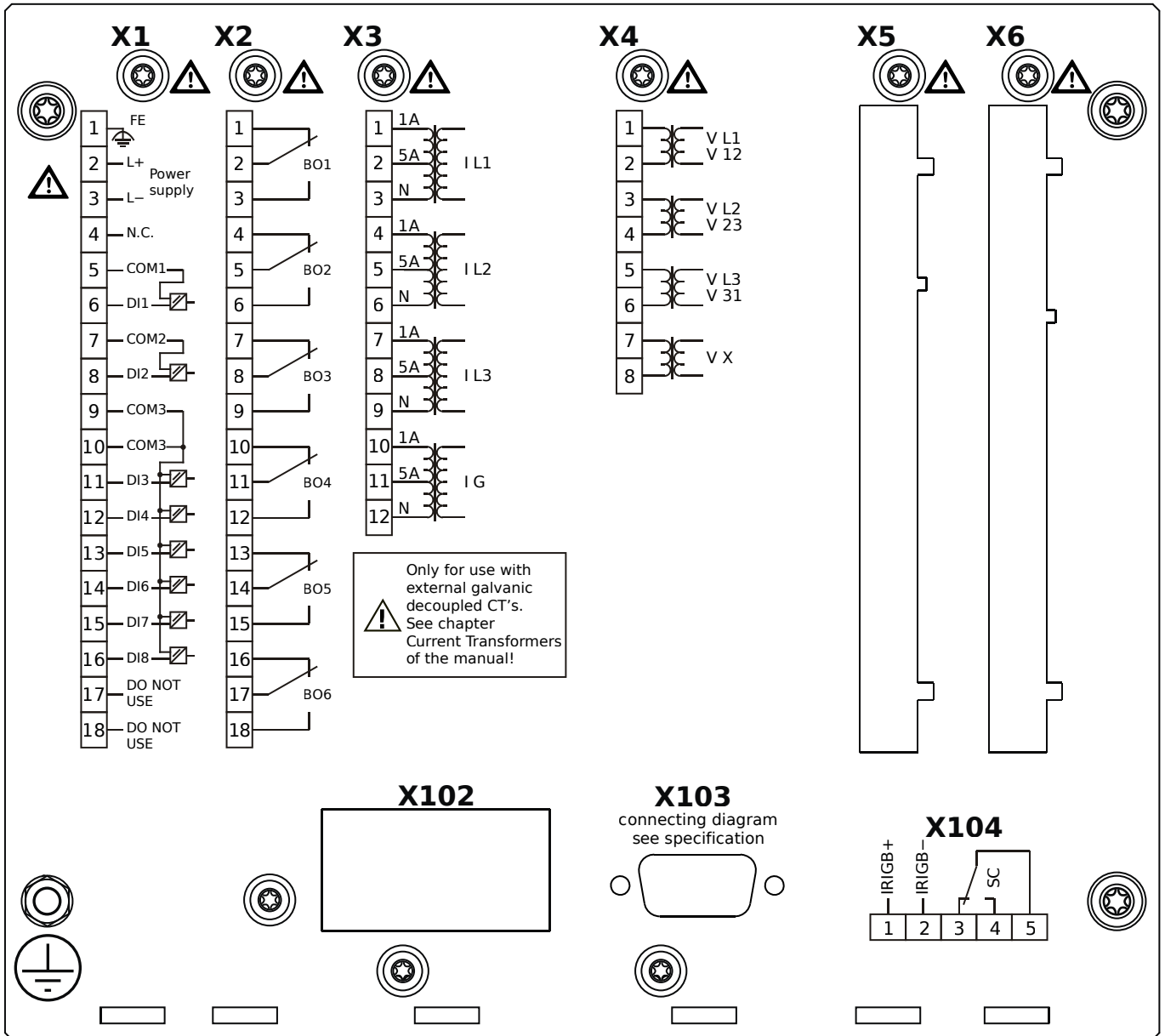

Housing B2, small display, door mounting

+ Conformal Coating (for installations in harsh environment)

- X1** – DI8-X1: Wide-range power supply unit, incl. 2 non-grouped digital inputs and 6 grouped digital inputs
- X2** – OR6: Assembly Group with 6 Output Relays (Changeover / Form C)
- X3** – TI: Standard current measuring card
- X4** – TU: Card with 4 voltage transformer measuring inputs (0 ... 800 VAC, under UL: 0 ... 600 VAC)
- X103** – Modbus RTU / IEC 60870-5-103 / DNP3.0 RTU, RS485, D-SUB
- X104** – IRIG-B00X, incl. System Contact (Supervision Contact)

MRA4-2A0AHA

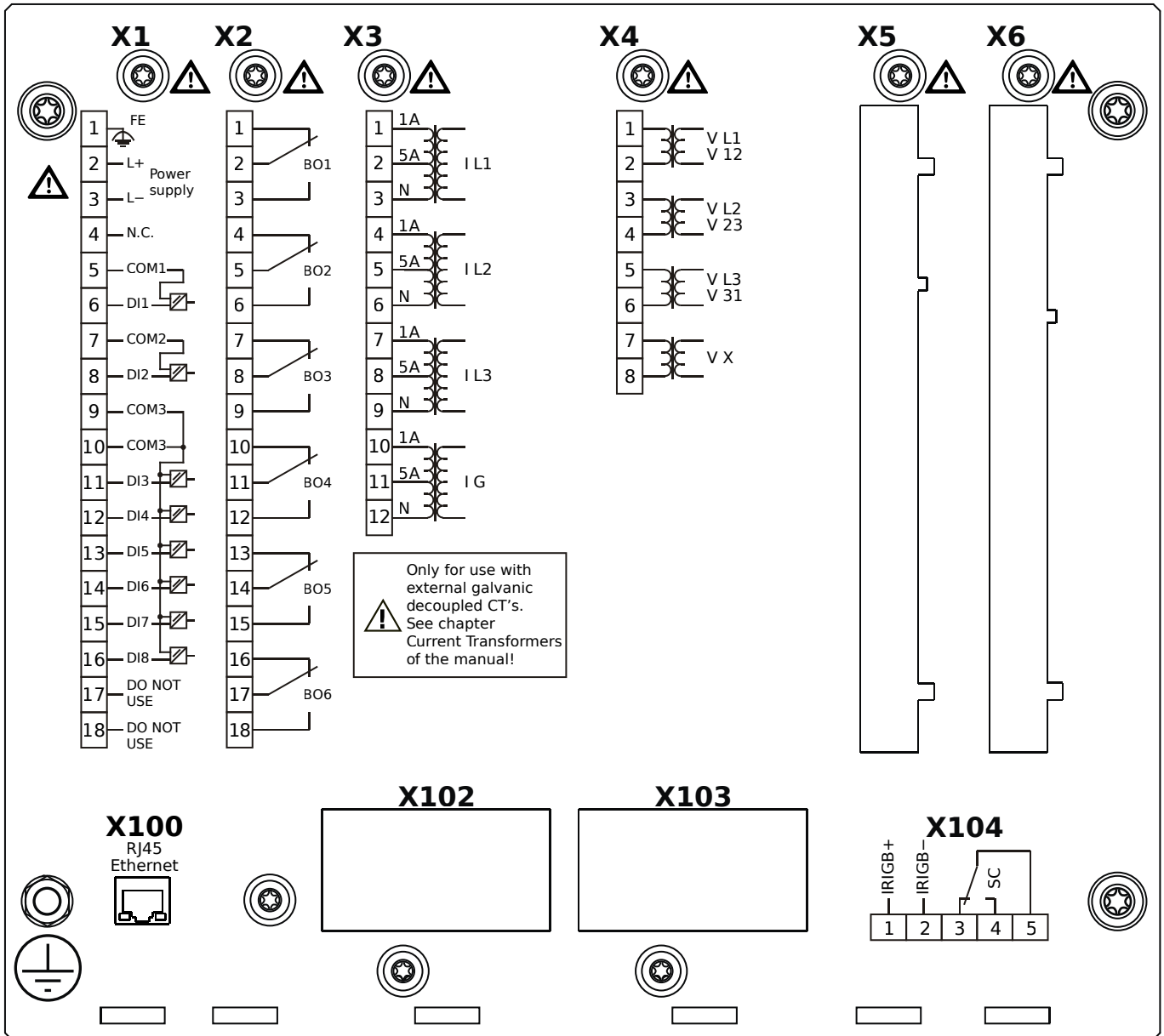

Housing B2, small display, door mounting

- X1** – DI8-X1: Wide-range power supply unit, incl. 2 non-grouped digital inputs and 6 grouped digital inputs
- X2** – OR6: Assembly Group with 6 Output Relays (Changeover / Form C)
- X3** – TI: Standard current measuring card
- X4** – TU: Card with 4 voltage transformer measuring inputs (0 ... 800 VAC, under UL: 0 ... 600 VAC)
- X100** – IEC 61850 / Modbus TCP / DNP3.0 TCP/UDP, Ethernet interface, 100 Mbit/s, RJ45 (BASE100-FX)
- X104** – IRIG-B00X, incl. System Contact (Supervision Contact)

MRA4-2A0AHB

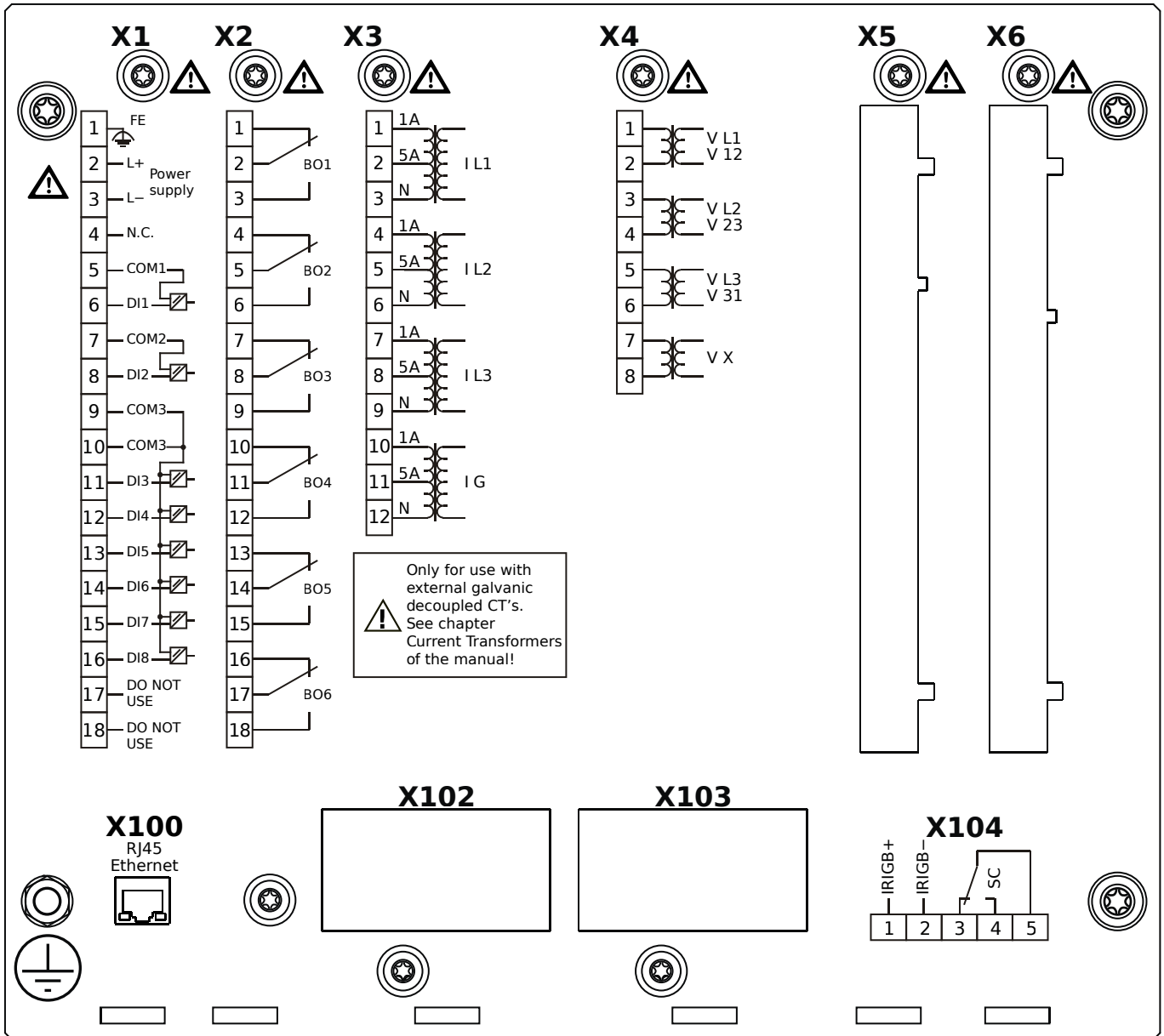

Housing B2, small display, door mounting

+ Conformal Coating (for installations in harsh environment)

- X1** – DI8-X1: Wide-range power supply unit, incl. 2 non-grouped digital inputs and 6 grouped digital inputs
- X2** – OR6: Assembly Group with 6 Output Relays (Changeover / Form C)
- X3** – TI: Standard current measuring card
- X4** – TU: Card with 4 voltage transformer measuring inputs (0 ... 800 VAC, under UL: 0 ... 600 VAC)
- X100** – IEC 61850 / Modbus TCP / DNP3.0 TCP/UDP, Ethernet interface, 100 Mbit/s, RJ45 (BASE100-FX)
- X104** – IRIG-B00X, incl. System Contact (Supervision Contact)

MRA4-2A0AIA

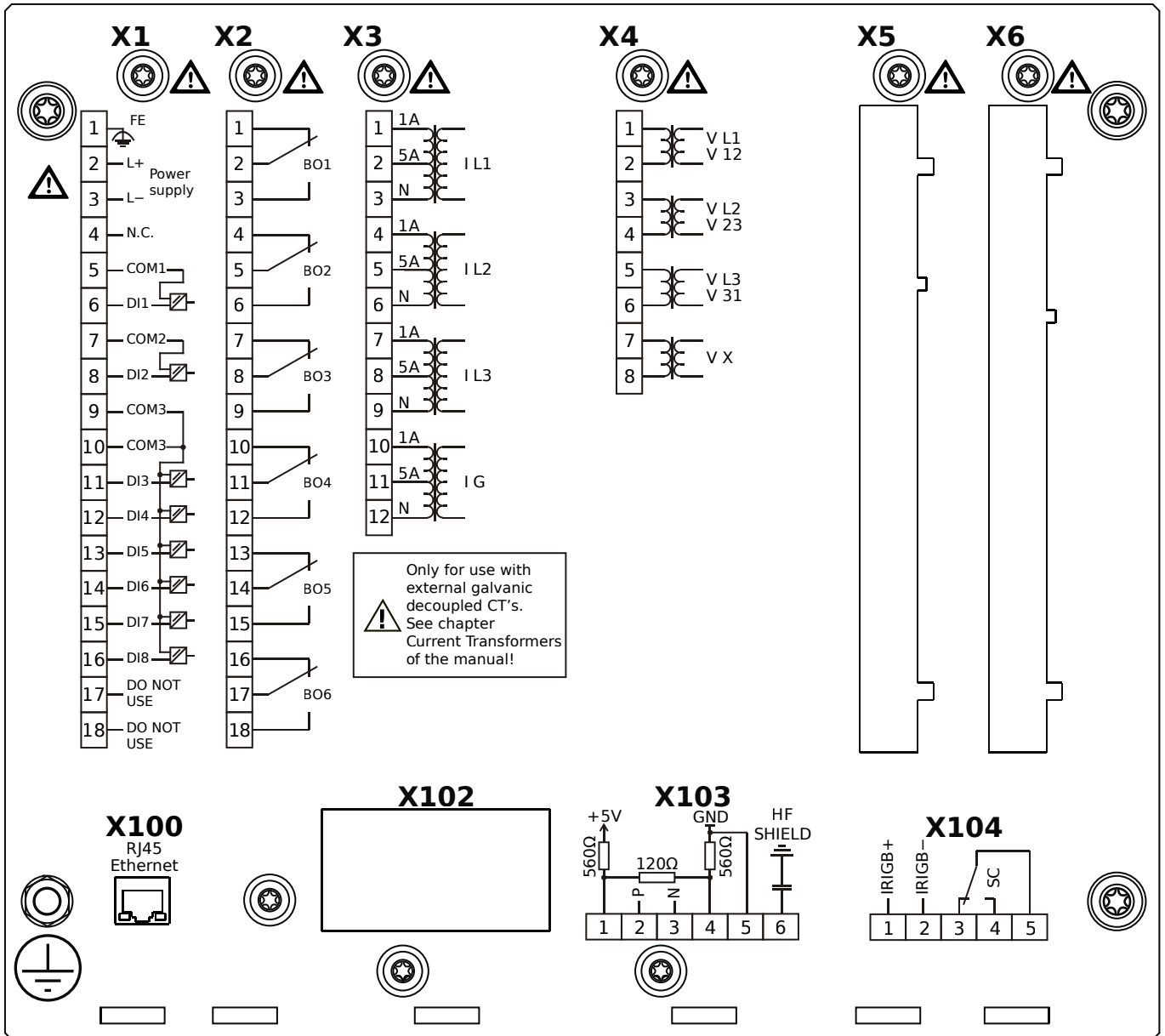

Housing B2, small display, door mounting

- X1** – DI8-X1: Wide-range power supply unit, incl. 2 non-grouped digital inputs and 6 grouped digital inputs
- X2** – OR6: Assembly Group with 6 Output Relays (Changeover / Form C)
- X3** – TI: Standard current measuring card
- X4** – TU: Card with 4 voltage transformer measuring inputs (0 ... 800 VAC, under UL: 0 ... 600 VAC)
- X100** – Modbus TCP / DNP3.0 TCP/UDP, Ethernet interface, 100 Mbit/s, RJ45 (BASE100-FX)
- X103** – IEC 60870-5-103 / Modbus RTU / DNP3.0 RTU, RS485, Terminals
- X104** – IRIG-B00X, incl. System Contact (Supervision Contact)

MRA4-2A0AIB

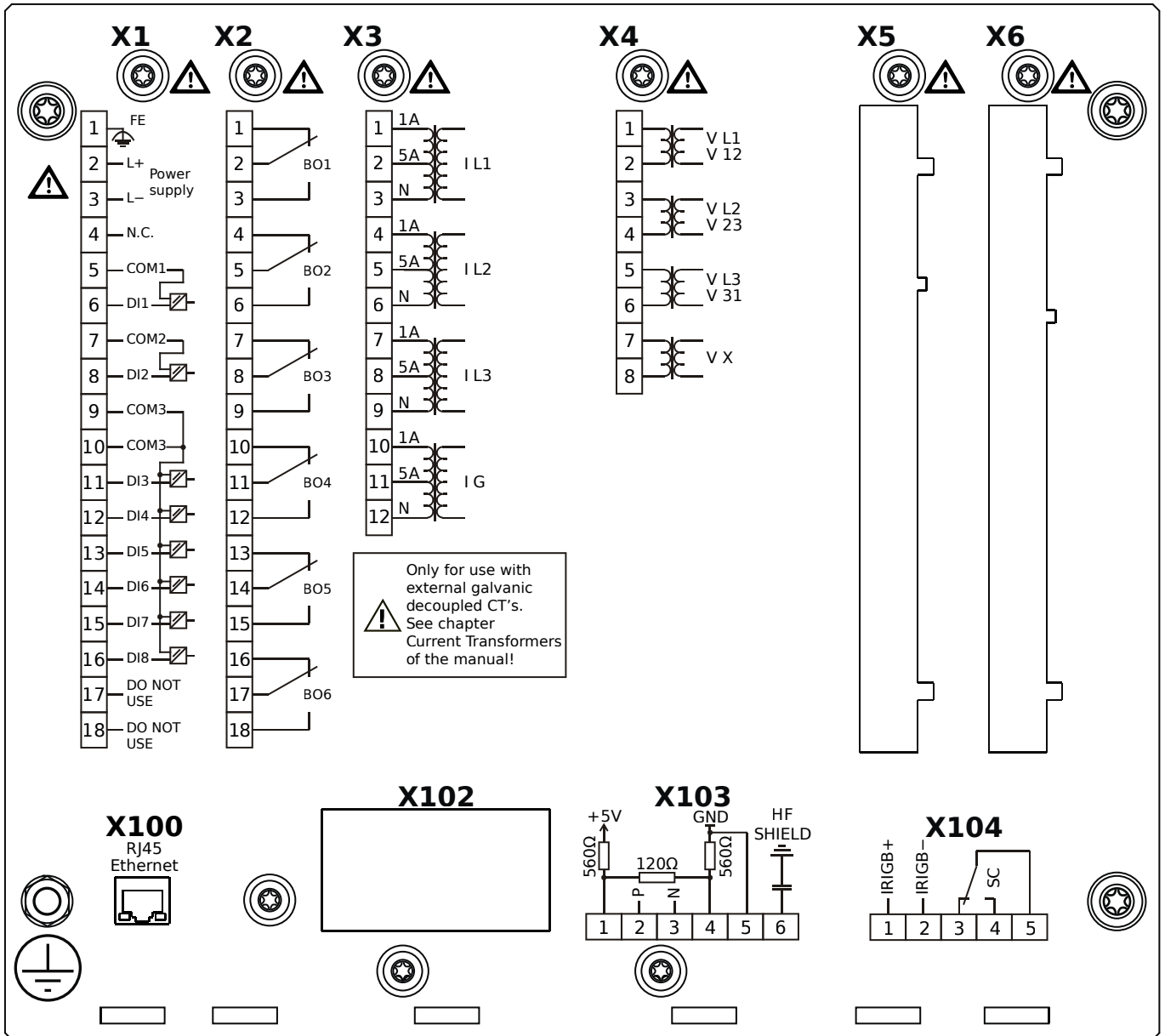

Housing B2, small display, door mounting

+ Conformal Coating (for installations in harsh environment)

- X1** – DI8-X1: Wide-range power supply unit, incl. 2 non-grouped digital inputs and 6 grouped digital inputs
- X2** – OR6: Assembly Group with 6 Output Relays (Changeover / Form C)
- X3** – TI: Standard current measuring card
- X4** – TU: Card with 4 voltage transformer measuring inputs (0 ... 800 VAC, under UL: 0 ... 600 VAC)
- X100** – Modbus TCP / DNP3.0 TCP/UDP, Ethernet interface, 100 Mbit/s, RJ45 (BASE100-FX)
- X103** – IEC 60870-5-103 / Modbus RTU / DNP3.0 RTU, RS485, Terminals
- X104** – IRIG-B00X, incl. System Contact (Supervision Contact)

MRA4-2A0AKA

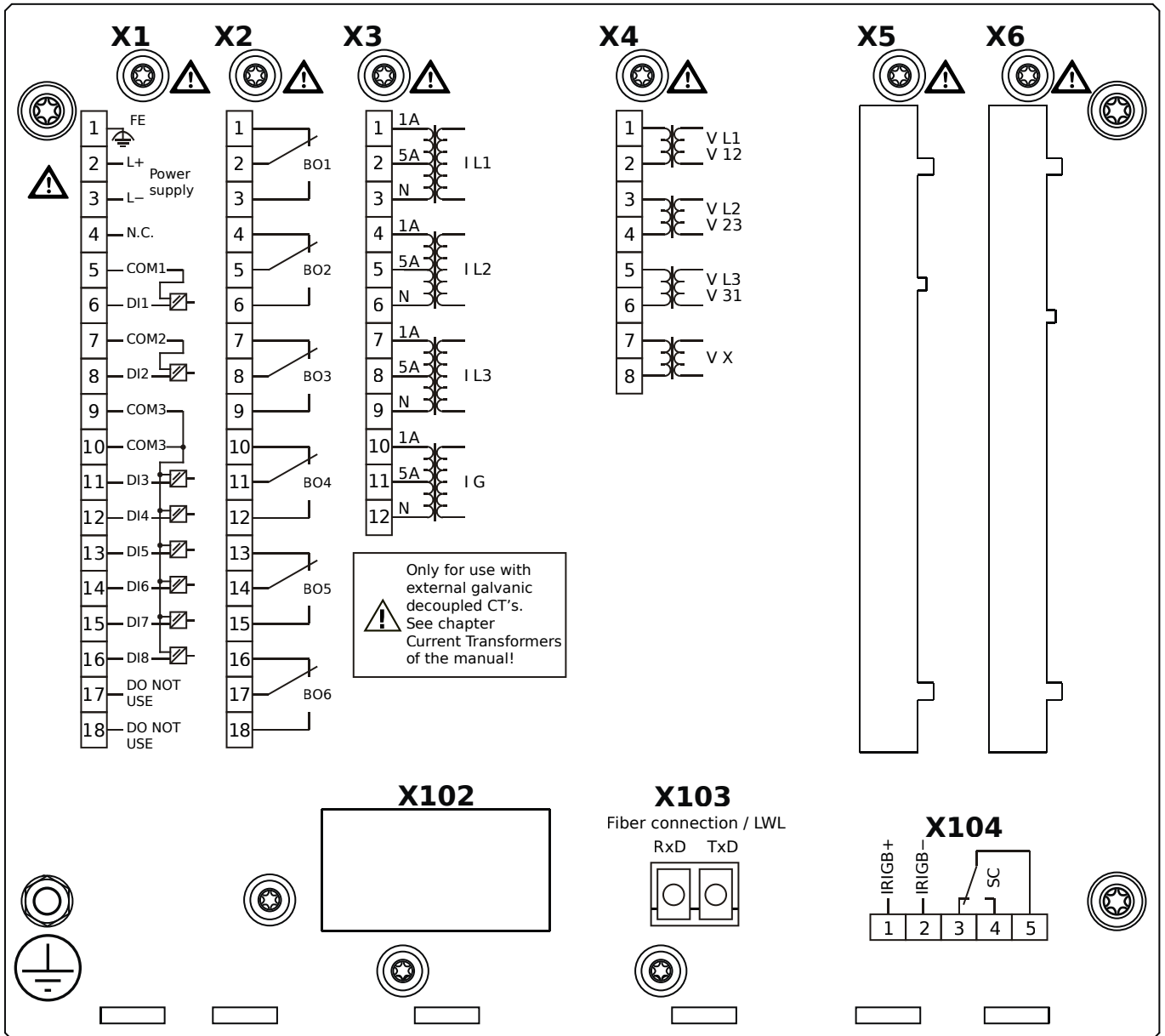

Housing B2, small display, door mounting

- X1** – DI8-X1: Wide-range power supply unit, incl. 2 non-grouped digital inputs and 6 grouped digital inputs
- X2** – OR6: Assembly Group with 6 Output Relays (Changeover / Form C)
- X3** – TI: Standard current measuring card
- X4** – TU: Card with 4 voltage transformer measuring inputs (0 ... 800 VAC, under UL: 0 ... 600 VAC)
- X103** – IEC 61850 / Modbus TCP / DNP3.0 TCP/UDP, Fiber optics interface, LC Connector
- X104** – IRIG-B00X, incl. System Contact (Supervision Contact)

MRA4-2A0AKB

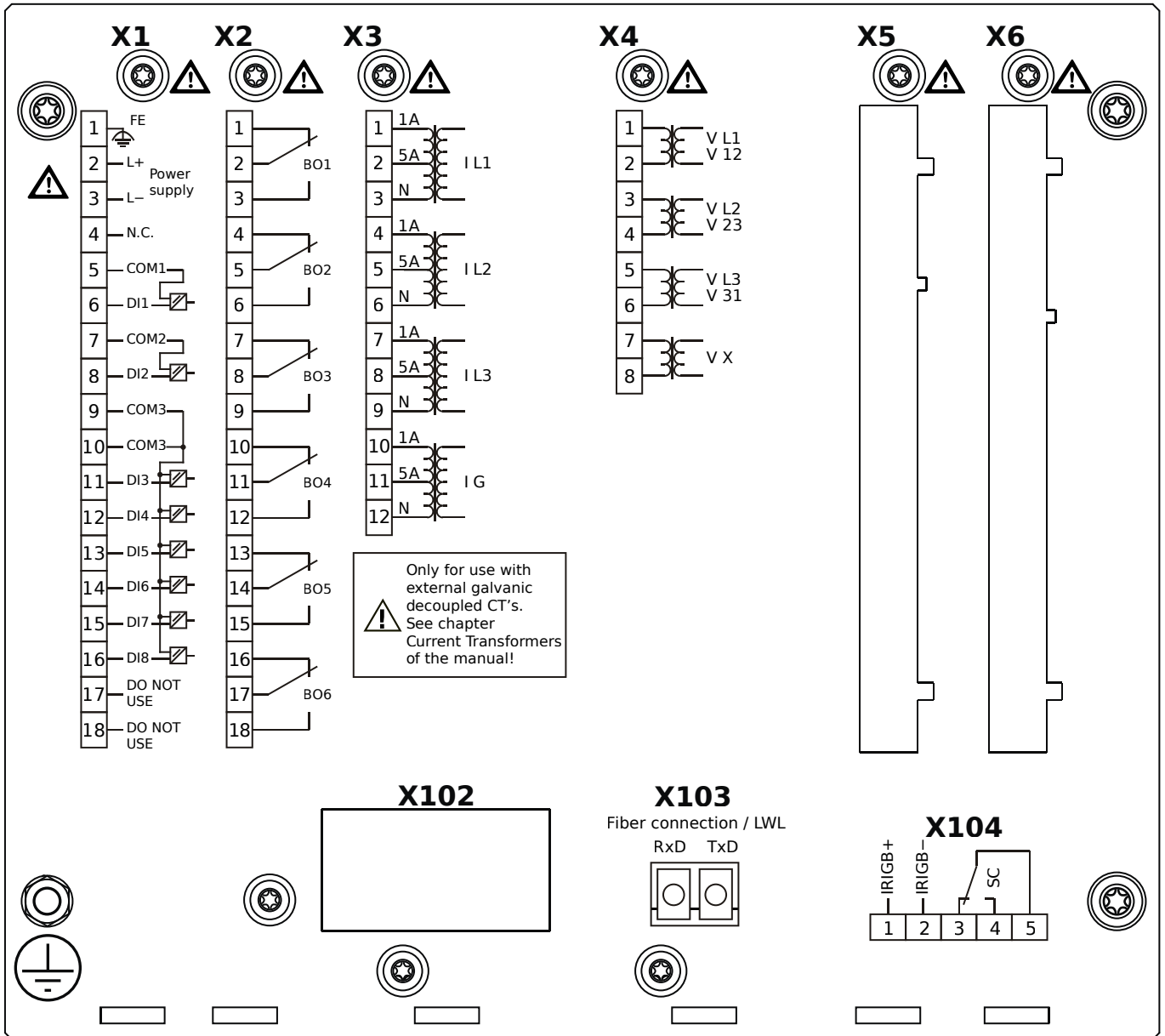

Housing B2, small display, door mounting

+ Conformal Coating (for installations in harsh environment)

- X1** – DI8-X1: Wide-range power supply unit, incl. 2 non-grouped digital inputs and 6 grouped digital inputs
- X2** – OR6: Assembly Group with 6 Output Relays (Changeover / Form C)
- X3** – TI: Standard current measuring card
- X4** – TU: Card with 4 voltage transformer measuring inputs (0 ... 800 VAC, under UL: 0 ... 600 VAC)
- X103** – IEC 61850 / Modbus TCP / DNP3.0 TCP/UDP, Fiber optics interface, LC Connector
- X104** – IRIG-B00X, incl. System Contact (Supervision Contact)

MRA4-2A0ALA

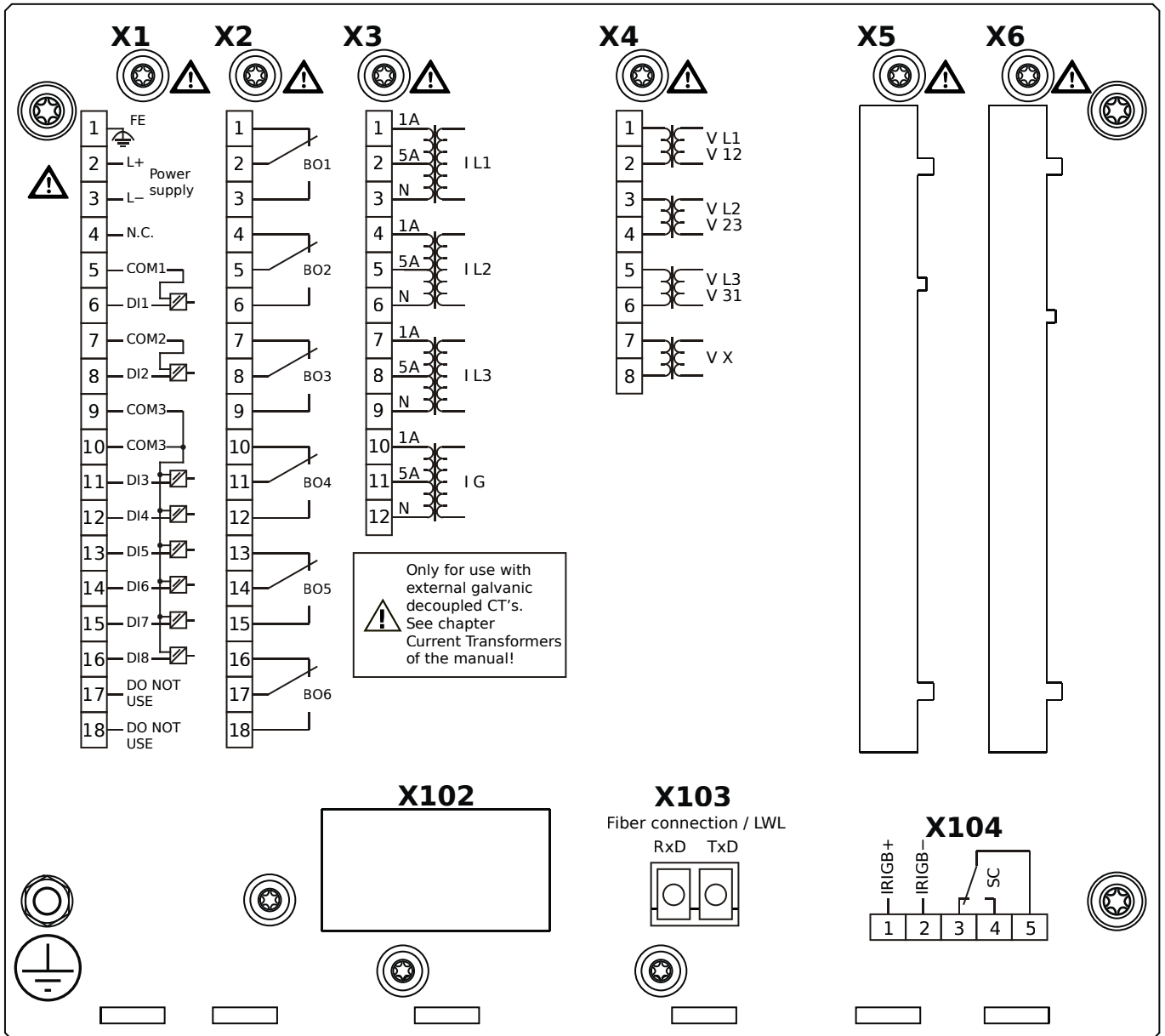

Housing B2, small display, door mounting

- X1** – DI8-X1: Wide-range power supply unit, incl. 2 non-grouped digital inputs and 6 grouped digital inputs
- X2** – OR6: Assembly Group with 6 Output Relays (Changeover / Form C)
- X3** – TI: Standard current measuring card
- X4** – TU: Card with 4 voltage transformer measuring inputs (0 ... 800 VAC, under UL: 0 ... 600 VAC)
- X103** – Modbus TCP / DNP3.0 TCP/UDP, Fiber optics interface, LC Connector
- X104** – IRIG-B00X, incl. System Contact (Supervision Contact)

MRA4-2A0ALB

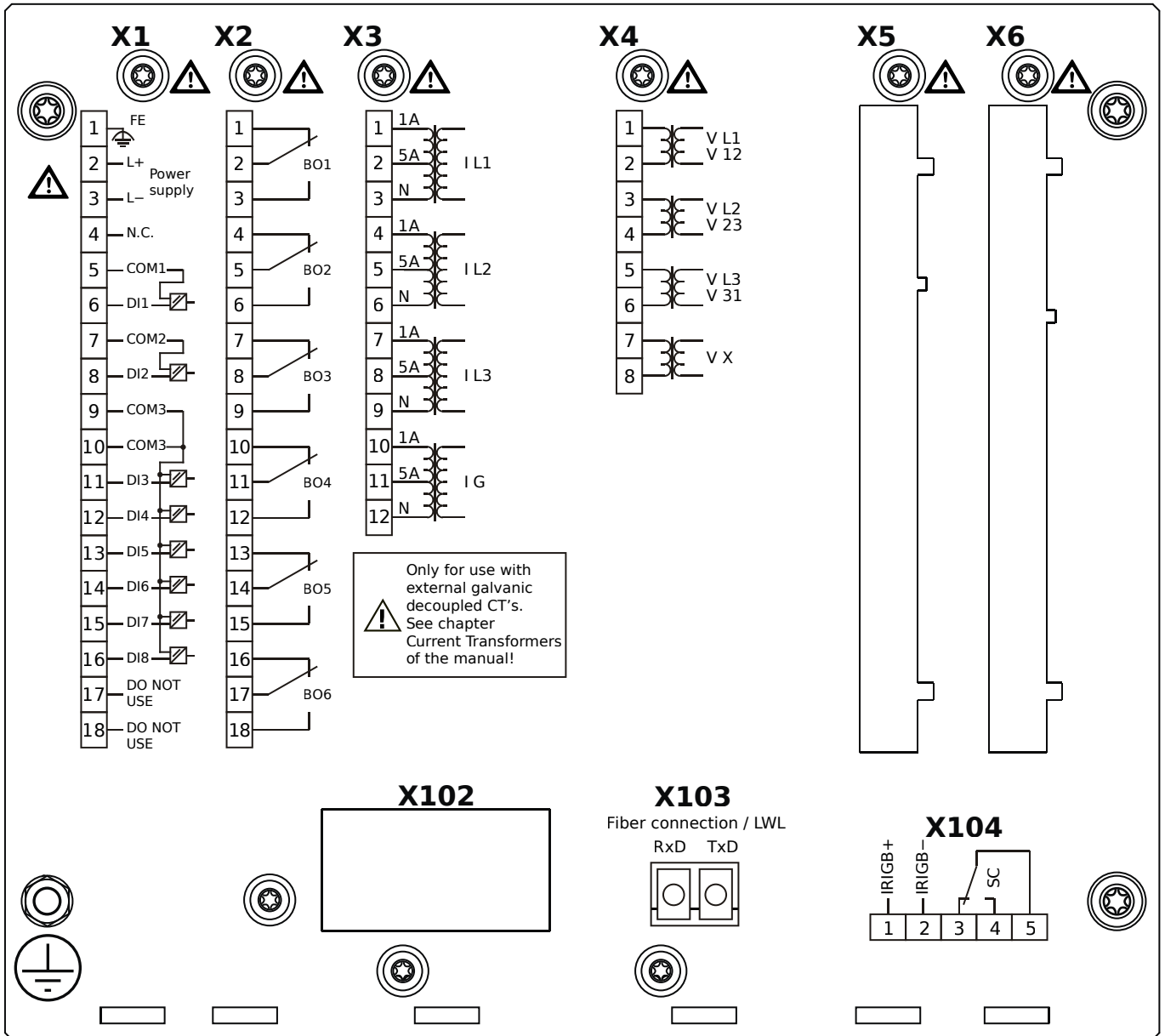

Housing B2, small display, door mounting

+ Conformal Coating (for installations in harsh environment)

- X1** – DI8-X1: Wide-range power supply unit, incl. 2 non-grouped digital inputs and 6 grouped digital inputs
- X2** – OR6: Assembly Group with 6 Output Relays (Changeover / Form C)
- X3** – TI: Standard current measuring card
- X4** – TU: Card with 4 voltage transformer measuring inputs (0 ... 800 VAC, under UL: 0 ... 600 VAC)
- X103** – Modbus TCP / DNP3.0 TCP/UDP, Fiber optics interface, LC Connector
- X104** – IRIG-B00X, incl. System Contact (Supervision Contact)

MRA4-2A0ATA

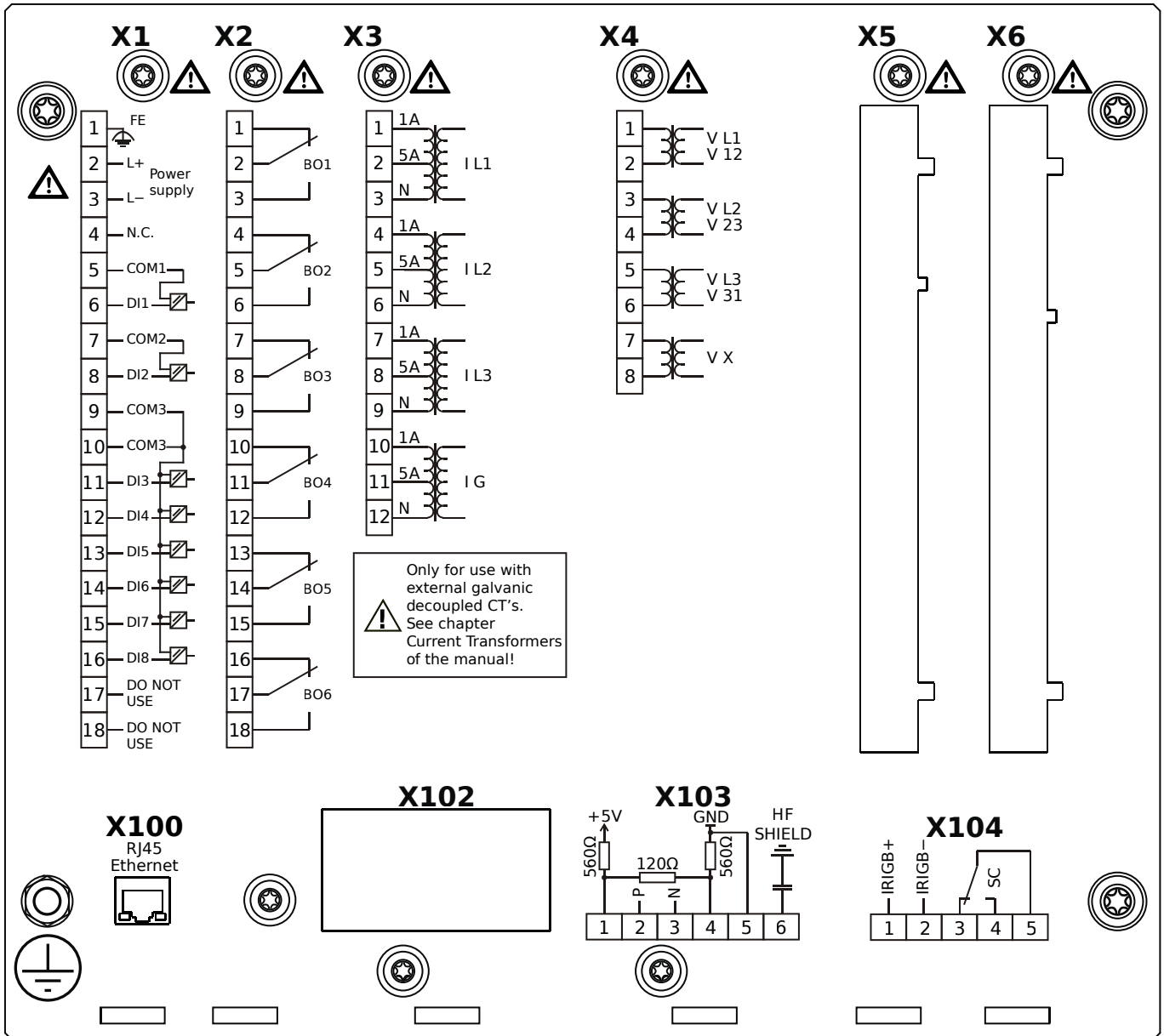

Housing B2, small display, door mounting

- X1** – DI8-X1: Wide-range power supply unit, incl. 2 non-grouped digital inputs and 6 grouped digital inputs
- X2** – OR6: Assembly Group with 6 Output Relays (Changeover / Form C)
- X3** – TI: Standard current measuring card
- X4** – TU: Card with 4 voltage transformer measuring inputs (0 ... 800 VAC, under UL: 0 ... 600 VAC)
- X100** – IEC 61850 / Modbus TCP / DNP3.0 TCP/UDP, Ethernet interface, 100 Mbit/s, RJ45 (BASE100-FX)
- X103** – IEC 60870-5-103 / Modbus RTU / DNP3.0 RTU, RS485, Terminals
- X104** – IRIG-B00X, incl. System Contact (Supervision Contact)

MRA4-2A0ATB

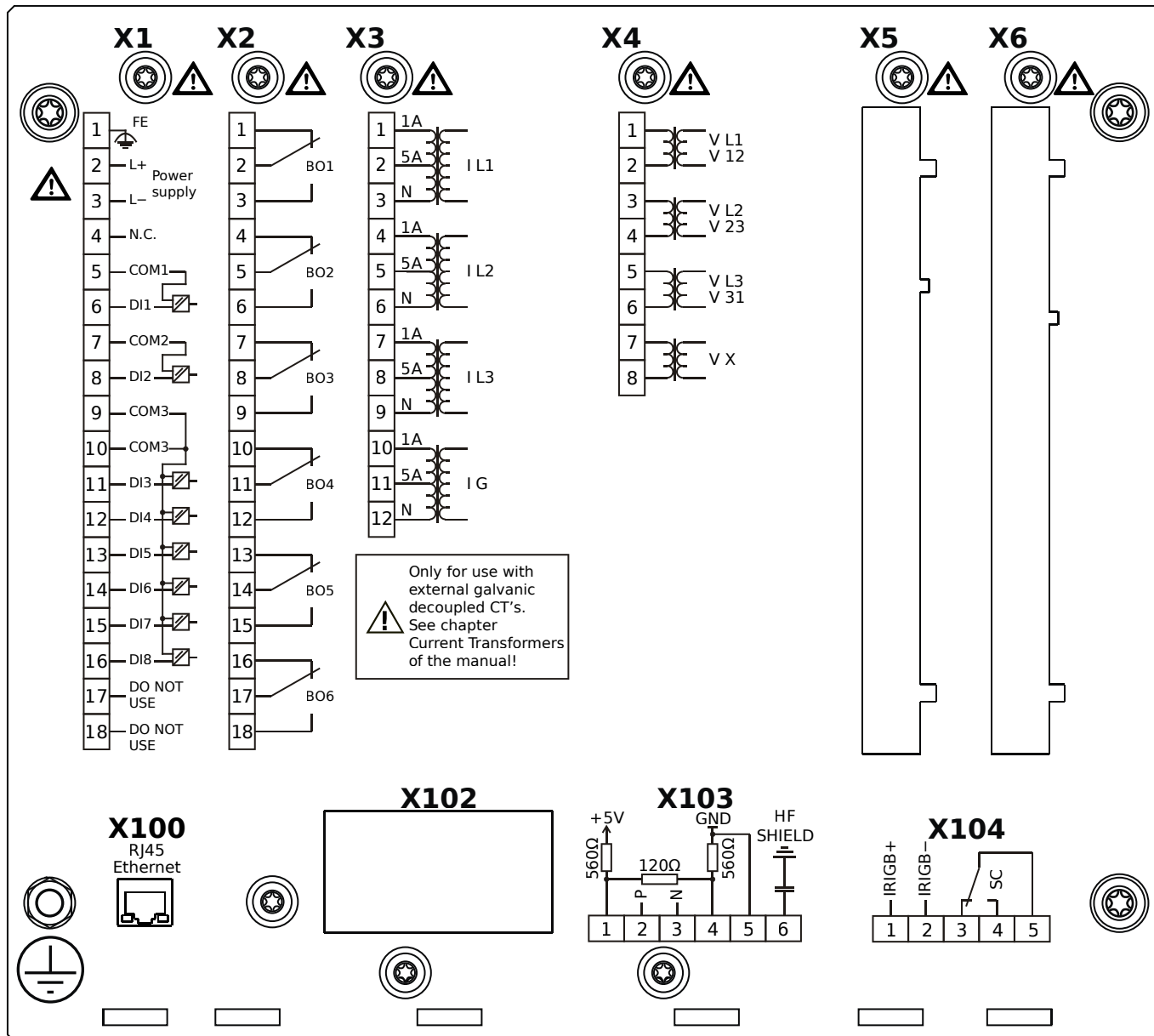

Housing B2, small display, door mounting

+ Conformal Coating (for installations in harsh environment)

- X1** – DI8-X1: Wide-range power supply unit, incl. 2 non-grouped digital inputs and 6 grouped digital inputs
- X2** – OR6: Assembly Group with 6 Output Relays (Changeover / Form C)
- X3** – TI: Standard current measuring card
- X4** – TU: Card with 4 voltage transformer measuring inputs (0 ... 800 VAC, under UL: 0 ... 600 VAC)
- X100** – IEC 61850 / Modbus TCP / DNP3.0 TCP/UDP, Ethernet interface, 100 Mbit/s, RJ45 (BASE100-FX)
- X103** – IEC 60870-5-103 / Modbus RTU / DNP3.0 RTU, RS485, Terminals
- X104** – IRIG-B00X, incl. System Contact (Supervision Contact)

MRA4-2A0BAA

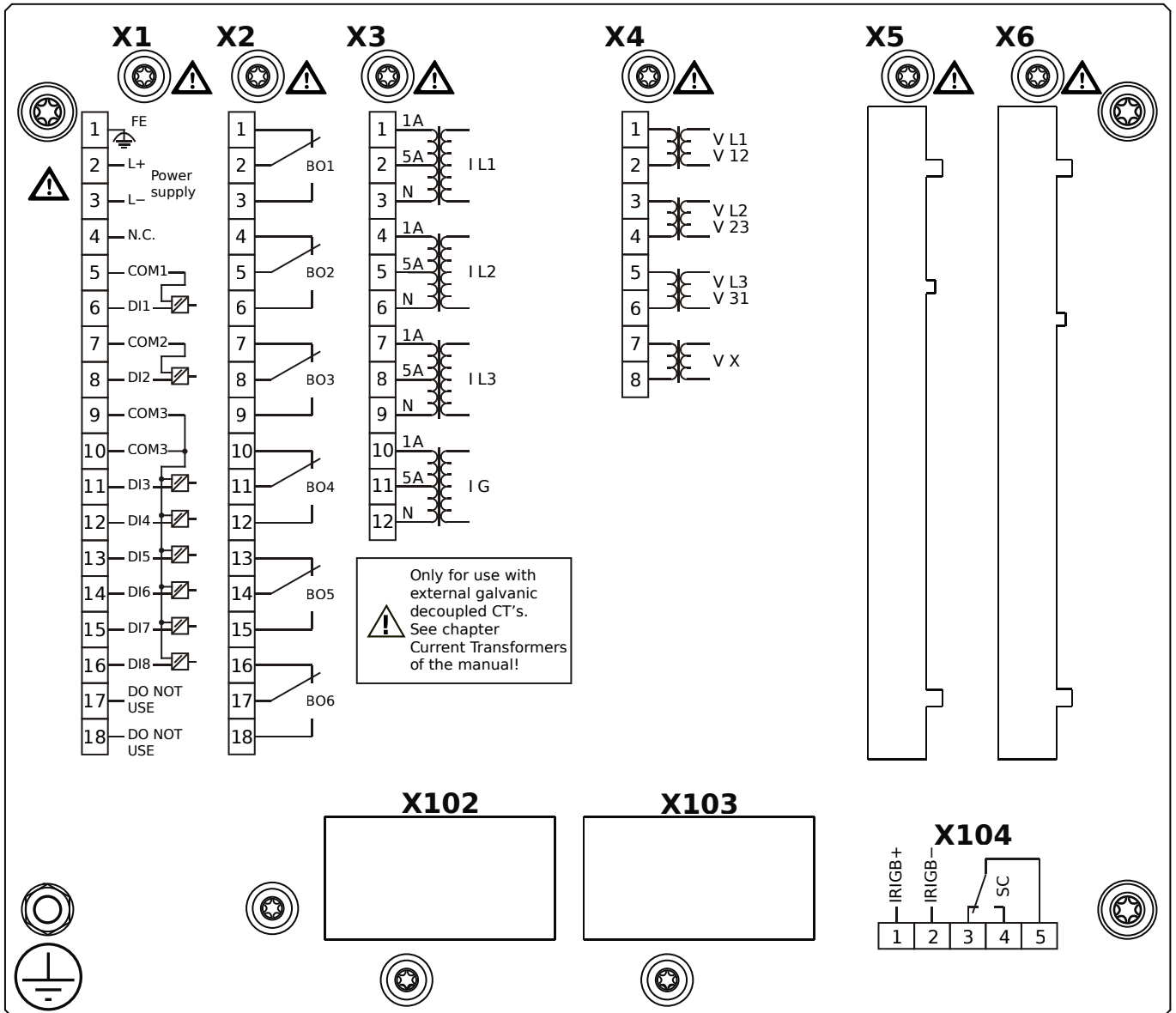

Housing B2, small display, 19" rack mounting

- X1** – DI8-X1: Wide-range power supply unit, incl. 2 non-grouped digital inputs and 6 grouped digital inputs
- X2** – OR6: Assembly Group with 6 Output Relays (Changeover / Form C)
- X3** – TI: Standard current measuring card
- X4** – TU: Card with 4 voltage transformer measuring inputs (0 ... 800 VAC, under UL: 0 ... 600 VAC)
- X104** – IRIG-B00X, incl. System Contact (Supervision Contact)

MRA4-2A0BAB

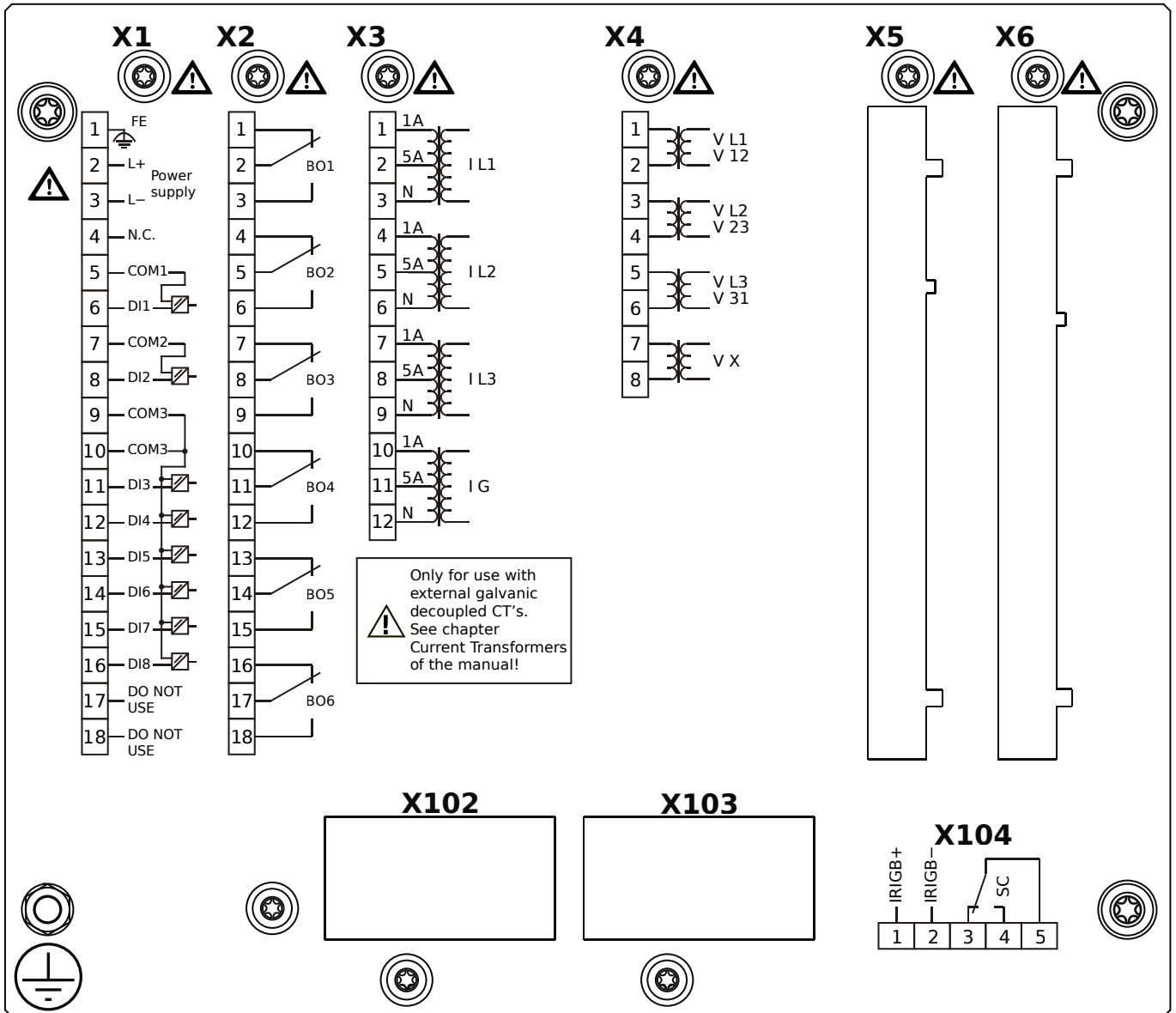

Housing B2, small display, 19" rack mounting

+ Conformal Coating (for installations in harsh environment)

- X1** – DI8-X1: Wide-range power supply unit, incl. 2 non-grouped digital inputs and 6 grouped digital inputs
- X2** – OR6: Assembly Group with 6 Output Relays (Changeover / Form C)
- X3** – TI: Standard current measuring card
- X4** – TU: Card with 4 voltage transformer measuring inputs (0 ... 800 VAC, under UL: 0 ... 600 VAC)
- X104** – IRIG-B00X, incl. System Contact (Supervision Contact)

MRA4-2A0BBA

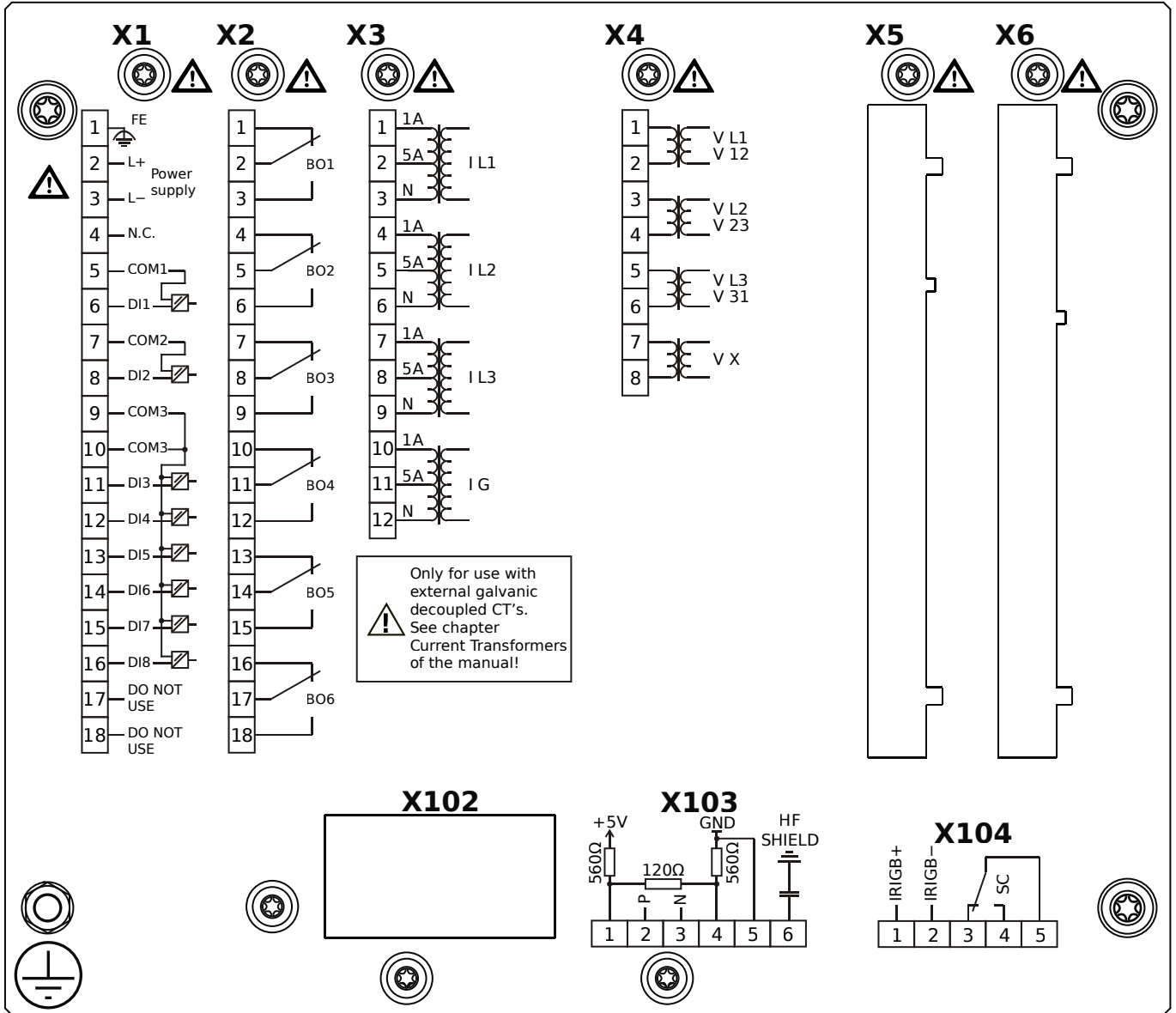

Housing B2, small display, 19" rack mounting

- X1** – DI8-X1: Wide-range power supply unit, incl. 2 non-grouped digital inputs and 6 grouped digital inputs
- X2** – OR6: Assembly Group with 6 Output Relays (Changeover / Form C)
- X3** – TI: Standard current measuring card
- X4** – TU: Card with 4 voltage transformer measuring inputs (0 ... 800 VAC, under UL: 0 ... 600 VAC)
- X103** – Modbus RTU / IEC 60870-5-103 / DNP3.0 RTU, RS485, Terminals
- X104** – IRIG-B00X, incl. System Contact (Supervision Contact)

MRA4-2A0BBB

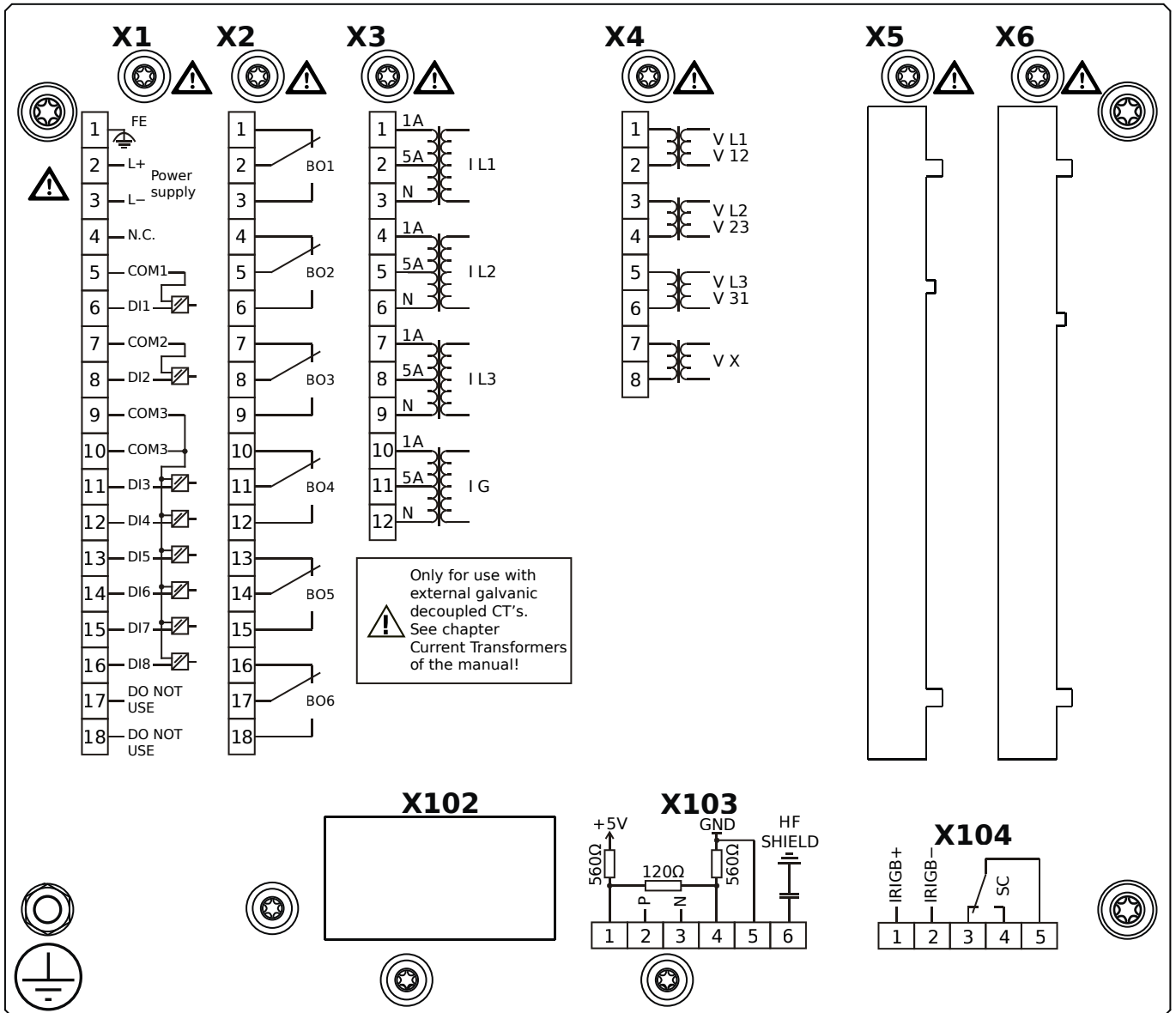

Housing B2, small display, 19" rack mounting

+ Conformal Coating (for installations in harsh environment)

- X1** – DI8-X1: Wide-range power supply unit, incl. 2 non-grouped digital inputs and 6 grouped digital inputs
- X2** – OR6: Assembly Group with 6 Output Relays (Changeover / Form C)
- X3** – TI: Standard current measuring card
- X4** – TU: Card with 4 voltage transformer measuring inputs (0 ... 800 VAC, under UL: 0 ... 600 VAC)
- X103** – Modbus RTU / IEC 60870-5-103 / DNP3.0 RTU, RS485, Terminals
- X104** – IRIG-B00X, incl. System Contact (Supervision Contact)

MRA4-2A0BCA

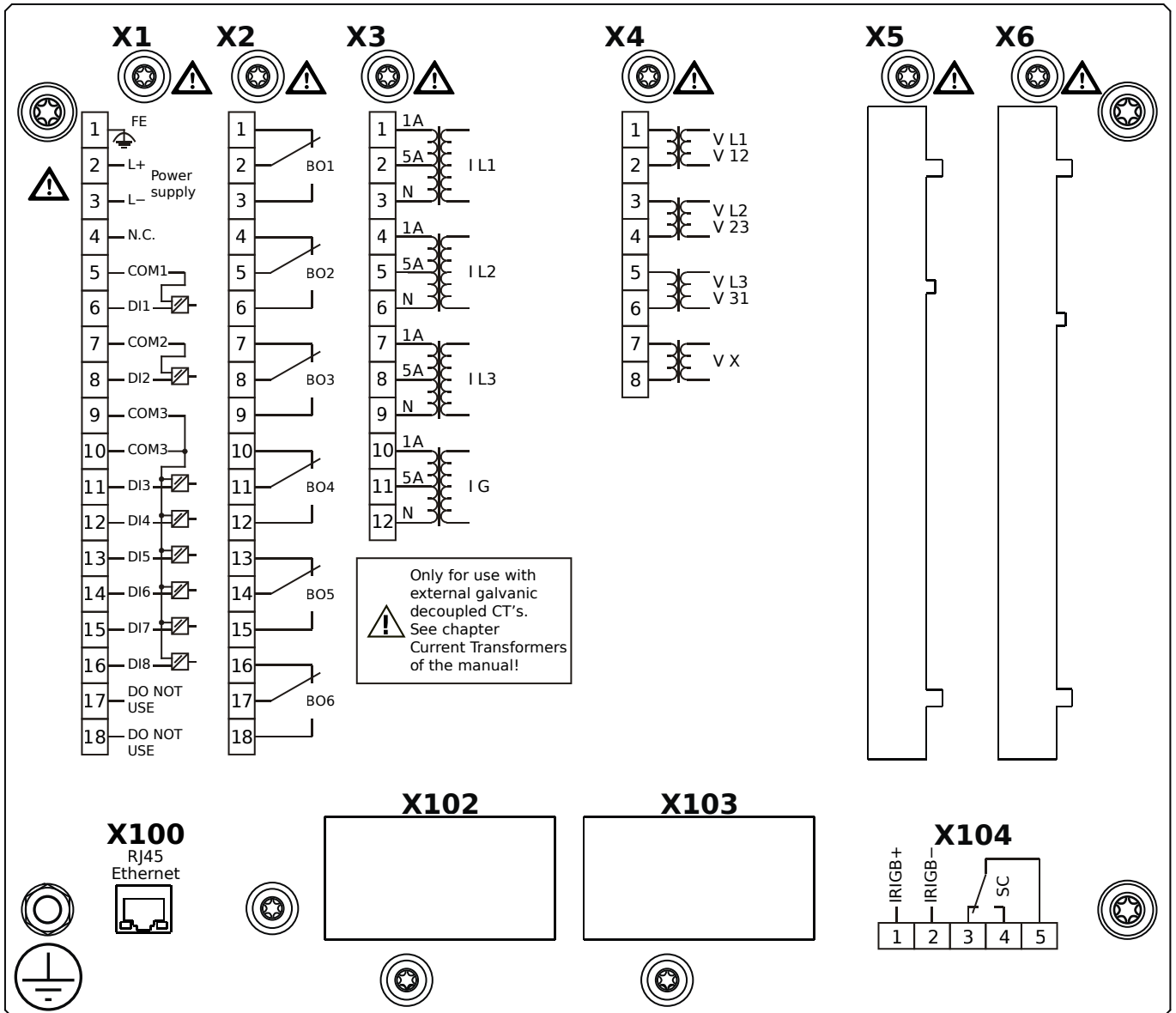

Housing B2, small display, 19" rack mounting

- X1** – DI8-X1: Wide-range power supply unit, incl. 2 non-grouped digital inputs and 6 grouped digital inputs
- X2** – OR6: Assembly Group with 6 Output Relays (Changeover / Form C)
- X3** – TI: Standard current measuring card
- X4** – TU: Card with 4 voltage transformer measuring inputs (0 ... 800 VAC, under UL: 0 ... 600 VAC)
- X100** – Modbus TCP / DNP3.0 TCP/UDP, Ethernet interface, 100 Mbit/s, RJ45 (BASE100-FX)
- X104** – IRIG-B00X, incl. System Contact (Supervision Contact)

MRA4-2A0BCB

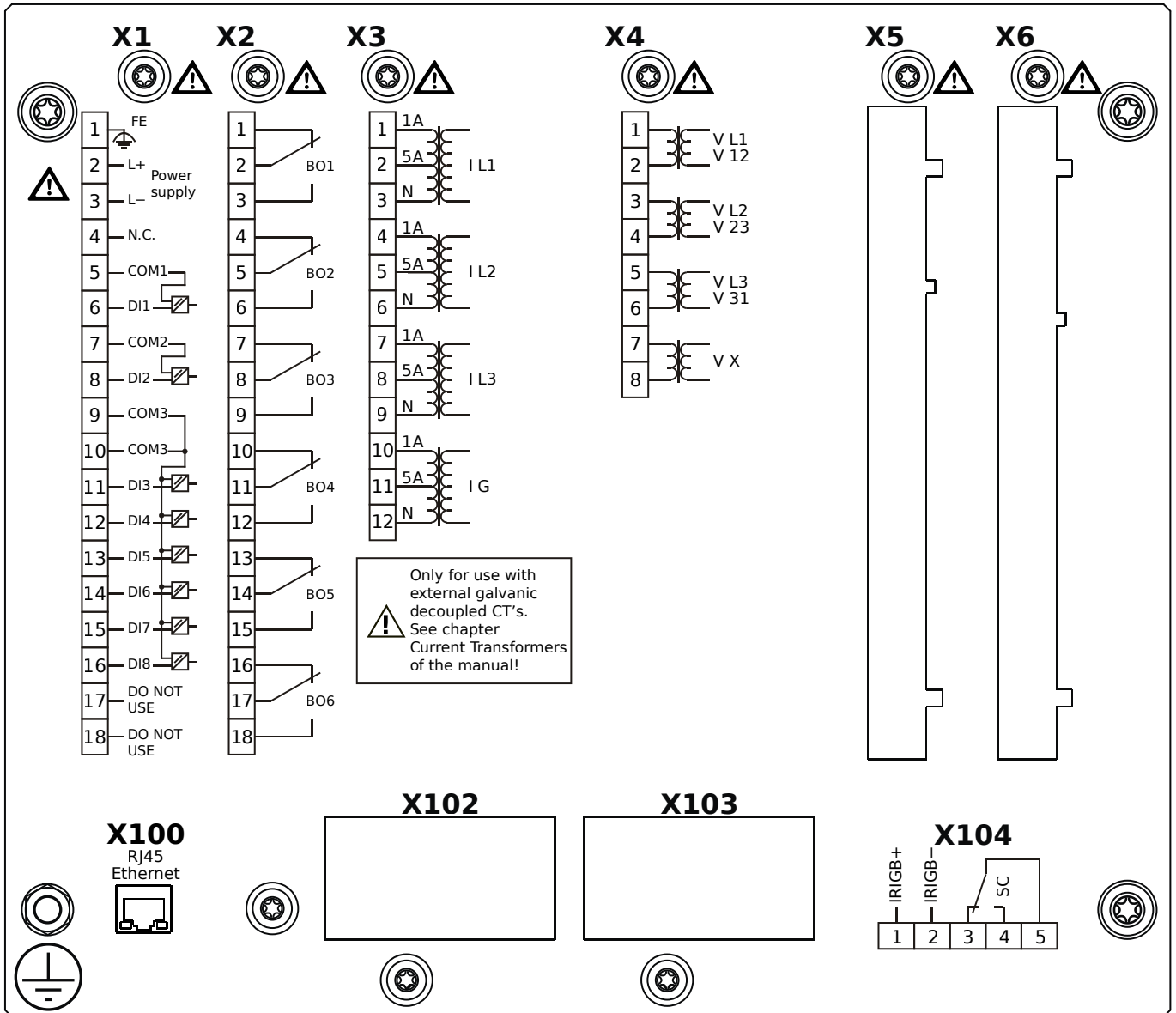

Housing B2, small display, 19" rack mounting

+ Conformal Coating (for installations in harsh environment)

- X1** – DI8-X1: Wide-range power supply unit, incl. 2 non-grouped digital inputs and 6 grouped digital inputs
- X2** – OR6: Assembly Group with 6 Output Relays (Changeover / Form C)
- X3** – TI: Standard current measuring card
- X4** – TU: Card with 4 voltage transformer measuring inputs (0 ... 800 VAC, under UL: 0 ... 600 VAC)
- X100** – Modbus TCP / DNP3.0 TCP/UDP, Ethernet interface, 100 Mbit/s, RJ45 (BASE100-FX)
- X104** – IRIG-B00X, incl. System Contact (Supervision Contact)

MRA4-2A0BDA

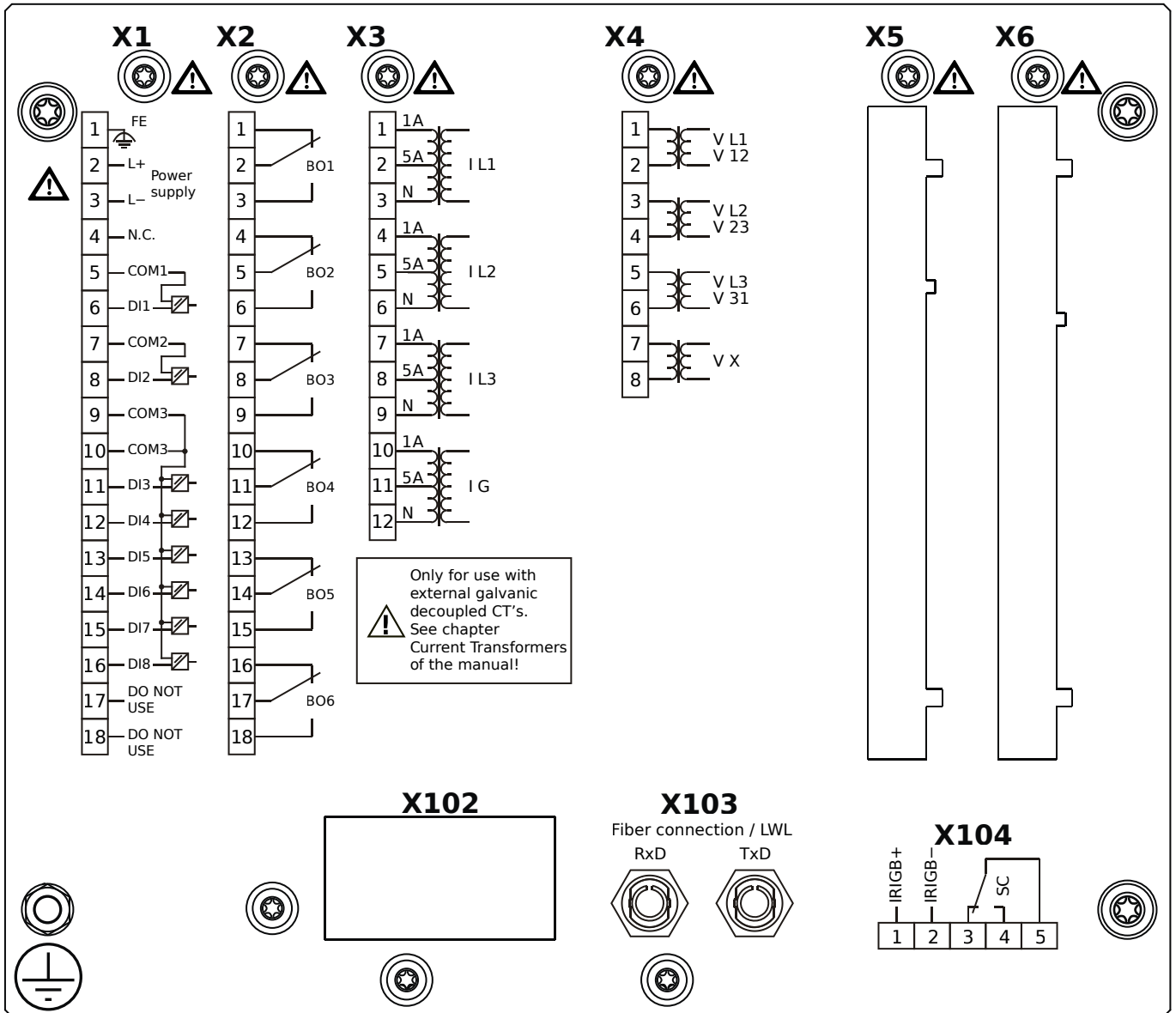

Housing B2, small display, 19" rack mounting

- X1** – DI8-X1: Wide-range power supply unit, incl. 2 non-grouped digital inputs and 6 grouped digital inputs
- X2** – OR6: Assembly Group with 6 Output Relays (Changeover / Form C)
- X3** – TI: Standard current measuring card
- X4** – TU: Card with 4 voltage transformer measuring inputs (0 ... 800 VAC, under UL: 0 ... 600 VAC)
- X103** – Profibus-DP, Fiber optics interface, ST Connector
- X104** – IRIG-B00X, incl. System Contact (Supervision Contact)

MRA4-2A0BDB

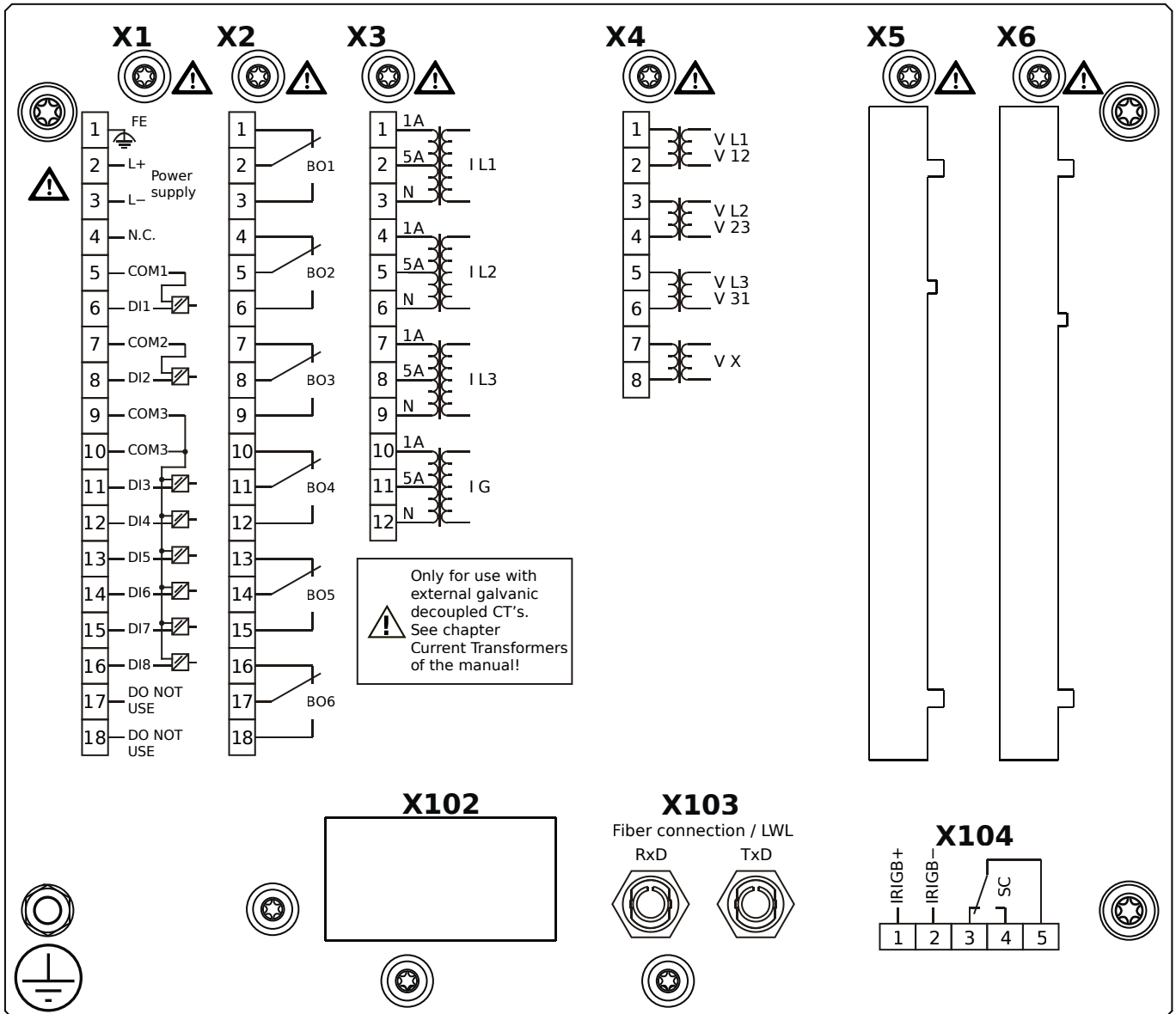

Housing B2, small display, 19" rack mounting

+ Conformal Coating (for installations in harsh environment)

- X1** – DI8-X1: Wide-range power supply unit, incl. 2 non-grouped digital inputs and 6 grouped digital inputs
- X2** – OR6: Assembly Group with 6 Output Relays (Changeover / Form C)
- X3** – TI: Standard current measuring card
- X4** – TU: Card with 4 voltage transformer measuring inputs (0 ... 800 VAC, under UL: 0 ... 600 VAC)
- X103** – Profibus-DP, Fiber optics interface, ST Connector
- X104** – IRIG-B00X, incl. System Contact (Supervision Contact)

MRA4-2A0BEA

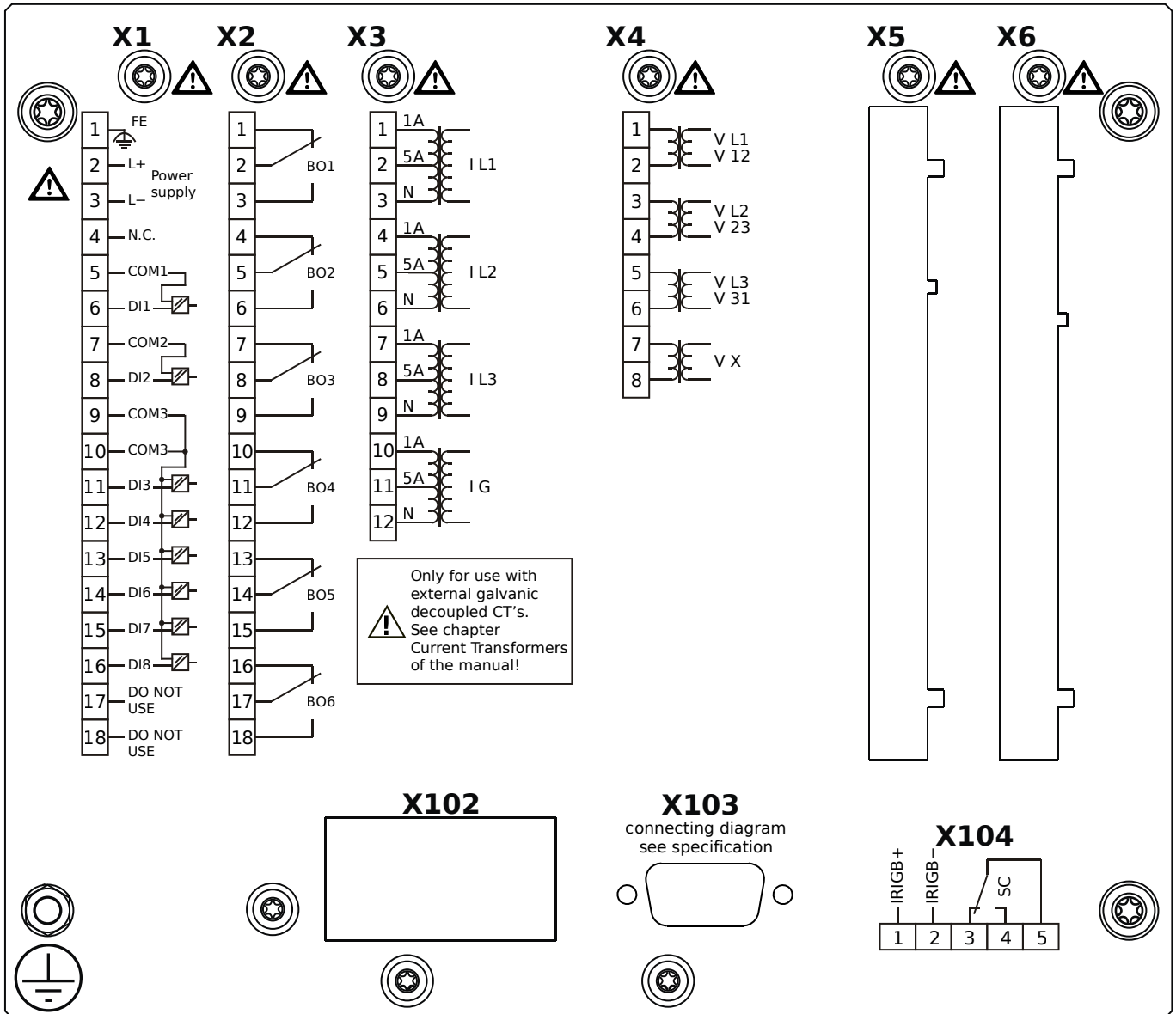

Housing B2, small display, 19" rack mounting

- X1** – DI8-X1: Wide-range power supply unit, incl. 2 non-grouped digital inputs and 6 grouped digital inputs
- X2** – OR6: Assembly Group with 6 Output Relays (Changeover / Form C)
- X3** – TI: Standard current measuring card
- X4** – TU: Card with 4 voltage transformer measuring inputs (0 ... 800 VAC, under UL: 0 ... 600 VAC)
- X103** – Profibus-DP, RS485, D-SUB
- X104** – IRIG-B00X, incl. System Contact (Supervision Contact)

MRA4-2A0BEB

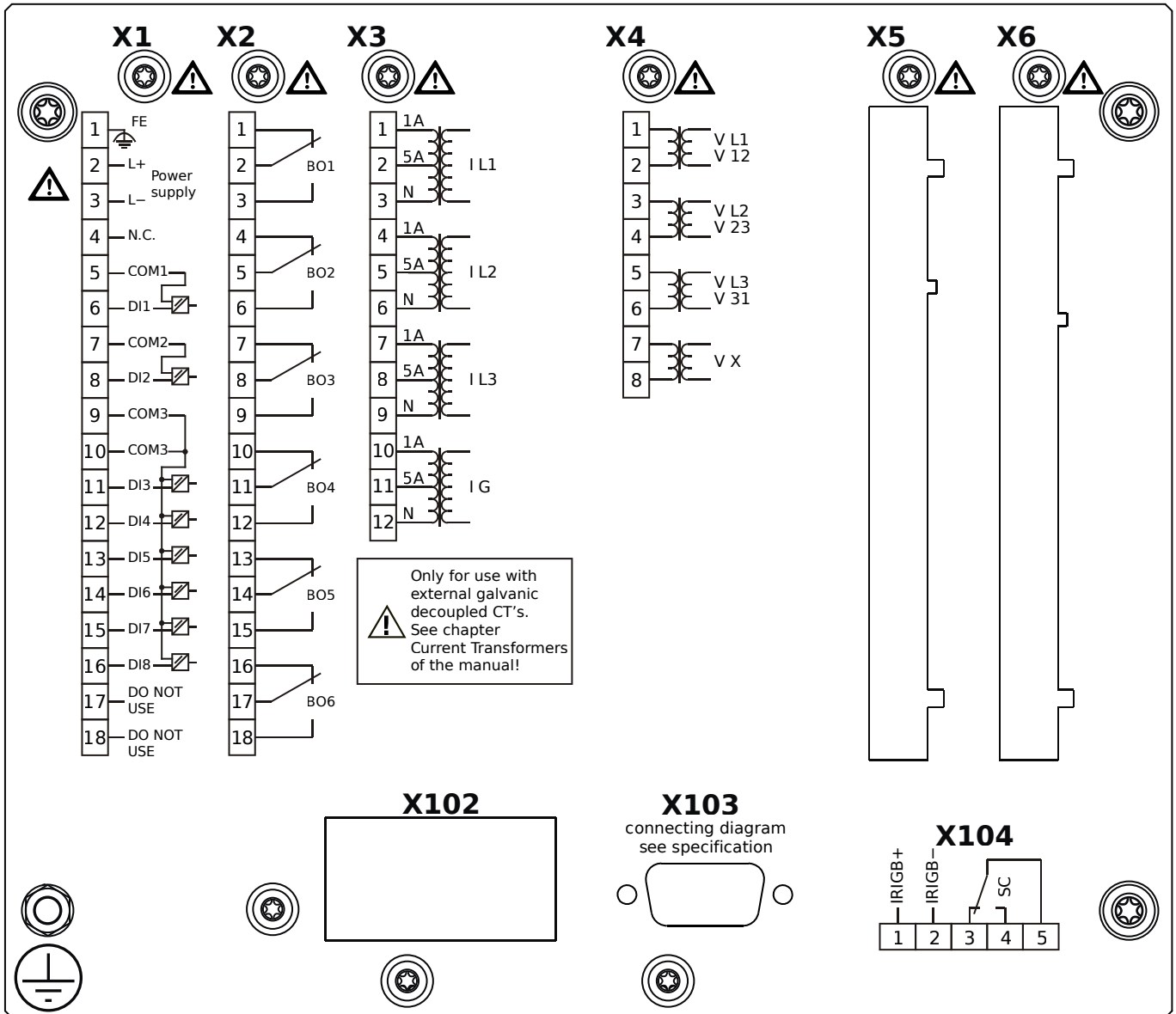

Housing B2, small display, 19" rack mounting

+ Conformal Coating (for installations in harsh environment)

- X1** – DI8-X1: Wide-range power supply unit, incl. 2 non-grouped digital inputs and 6 grouped digital inputs
- X2** – OR6: Assembly Group with 6 Output Relays (Changeover / Form C)
- X3** – TI: Standard current measuring card
- X4** – TU: Card with 4 voltage transformer measuring inputs (0 ... 800 VAC, under UL: 0 ... 600 VAC)
- X103** – Profibus-DP, RS485, D-SUB
- X104** – IRIG-B00X, incl. System Contact (Supervision Contact)

MRA4-2A0BFA

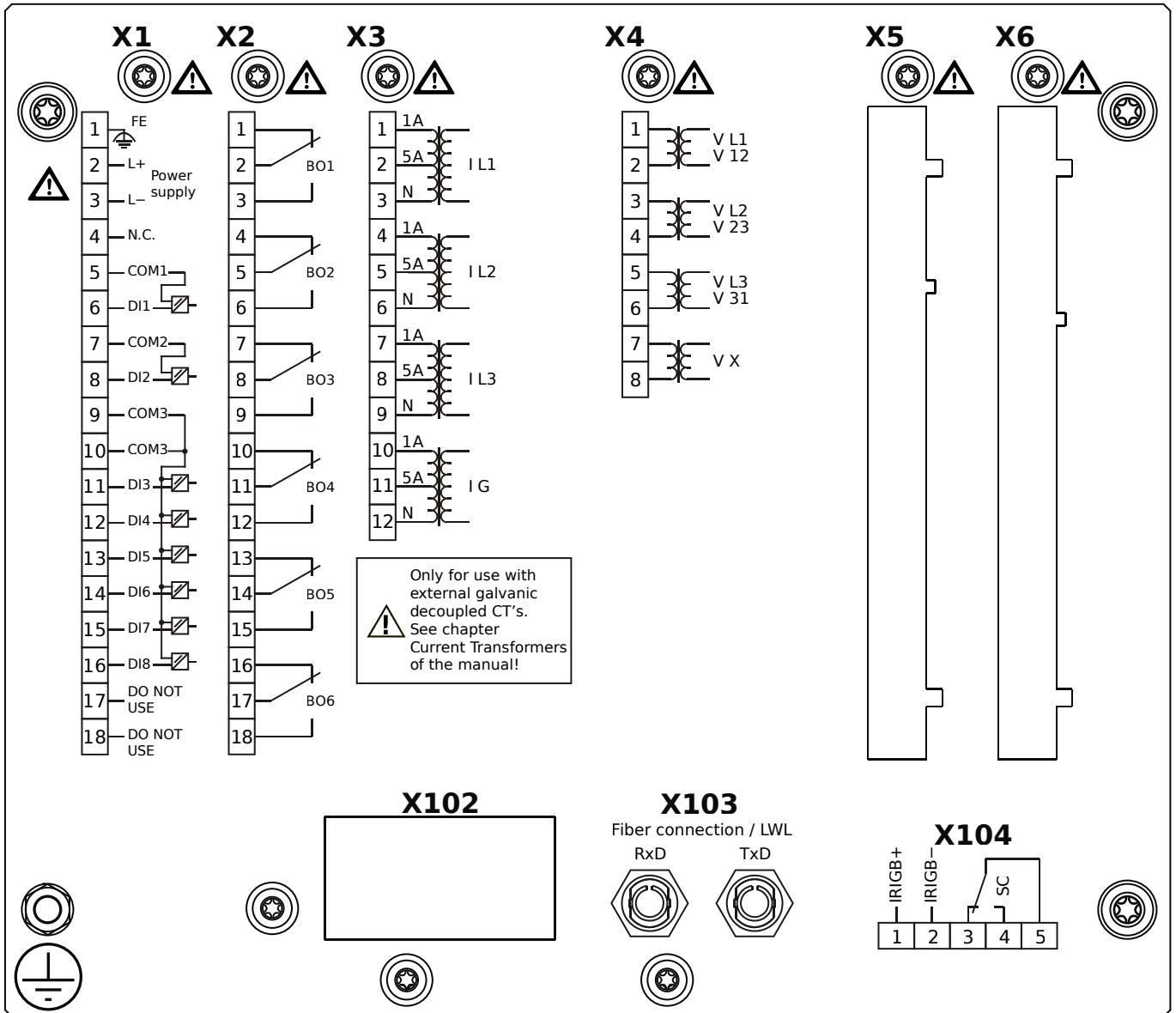

Housing B2, small display, 19" rack mounting

- X1** – DI8-X1: Wide-range power supply unit, incl. 2 non-grouped digital inputs and 6 grouped digital inputs
- X2** – OR6: Assembly Group with 6 Output Relays (Changeover / Form C)
- X3** – TI: Standard current measuring card
- X4** – TU: Card with 4 voltage transformer measuring inputs (0 ... 800 VAC, under UL: 0 ... 600 VAC)
- X103** – Modbus RTU / IEC 60870-5-103 / DNP3.0 RTU, Fiber optics interface, ST Connector
- X104** – IRIG-B00X, incl. System Contact (Supervision Contact)

MRA4-2A0BFB

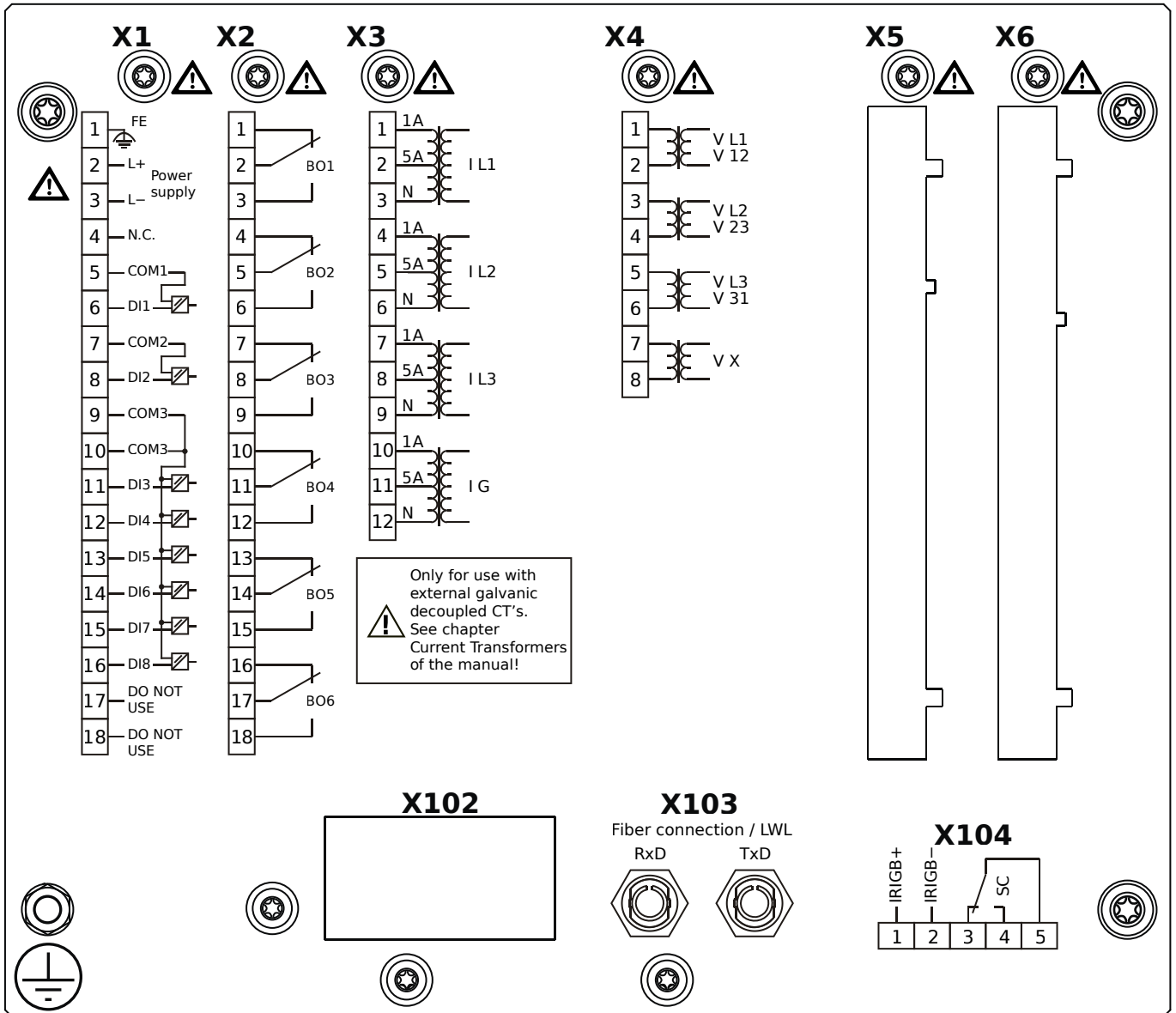

Housing B2, small display, 19" rack mounting

+ Conformal Coating (for installations in harsh environment)

- X1** – DI8-X1: Wide-range power supply unit, incl. 2 non-grouped digital inputs and 6 grouped digital inputs
- X2** – OR6: Assembly Group with 6 Output Relays (Changeover / Form C)
- X3** – TI: Standard current measuring card
- X4** – TU: Card with 4 voltage transformer measuring inputs (0 ... 800 VAC, under UL: 0 ... 600 VAC)
- X103** – Modbus RTU / IEC 60870-5-103 / DNP3.0 RTU, Fiber optics interface, ST Connector
- X104** – IRIG-B00X, incl. System Contact (Supervision Contact)

MRA4-2A0BGA

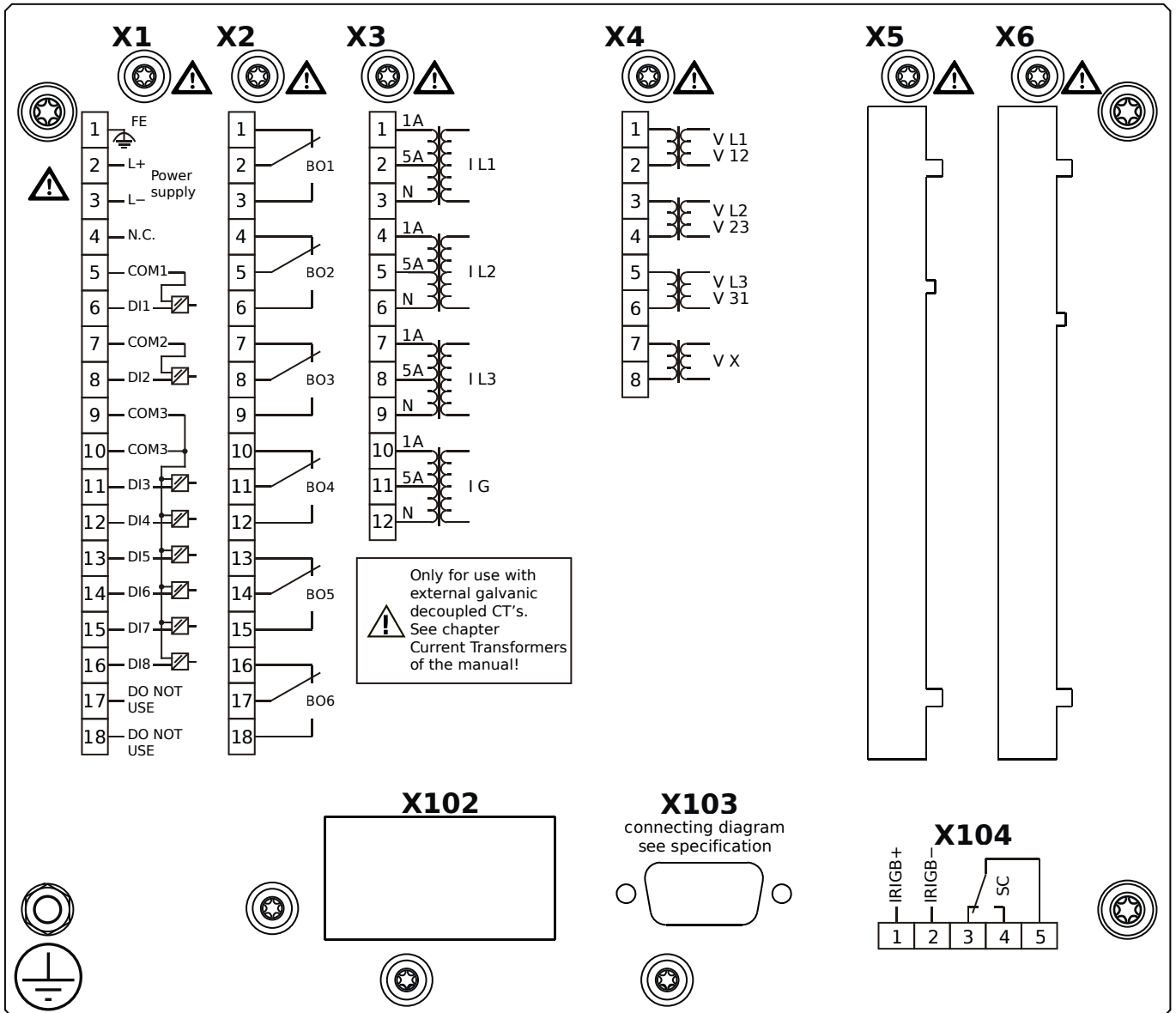

Housing B2, small display, 19" rack mounting

- X1** – DI8-X1: Wide-range power supply unit, incl. 2 non-grouped digital inputs and 6 grouped digital inputs
- X2** – OR6: Assembly Group with 6 Output Relays (Changeover / Form C)
- X3** – TI: Standard current measuring card
- X4** – TU: Card with 4 voltage transformer measuring inputs (0 ... 800 VAC, under UL: 0 ... 600 VAC)
- X103** – Modbus RTU / IEC 60870-5-103 / DNP3.0 RTU, RS485, D-SUB
- X104** – IRIG-B00X, incl. System Contact (Supervision Contact)

MRA4-2A0BGB

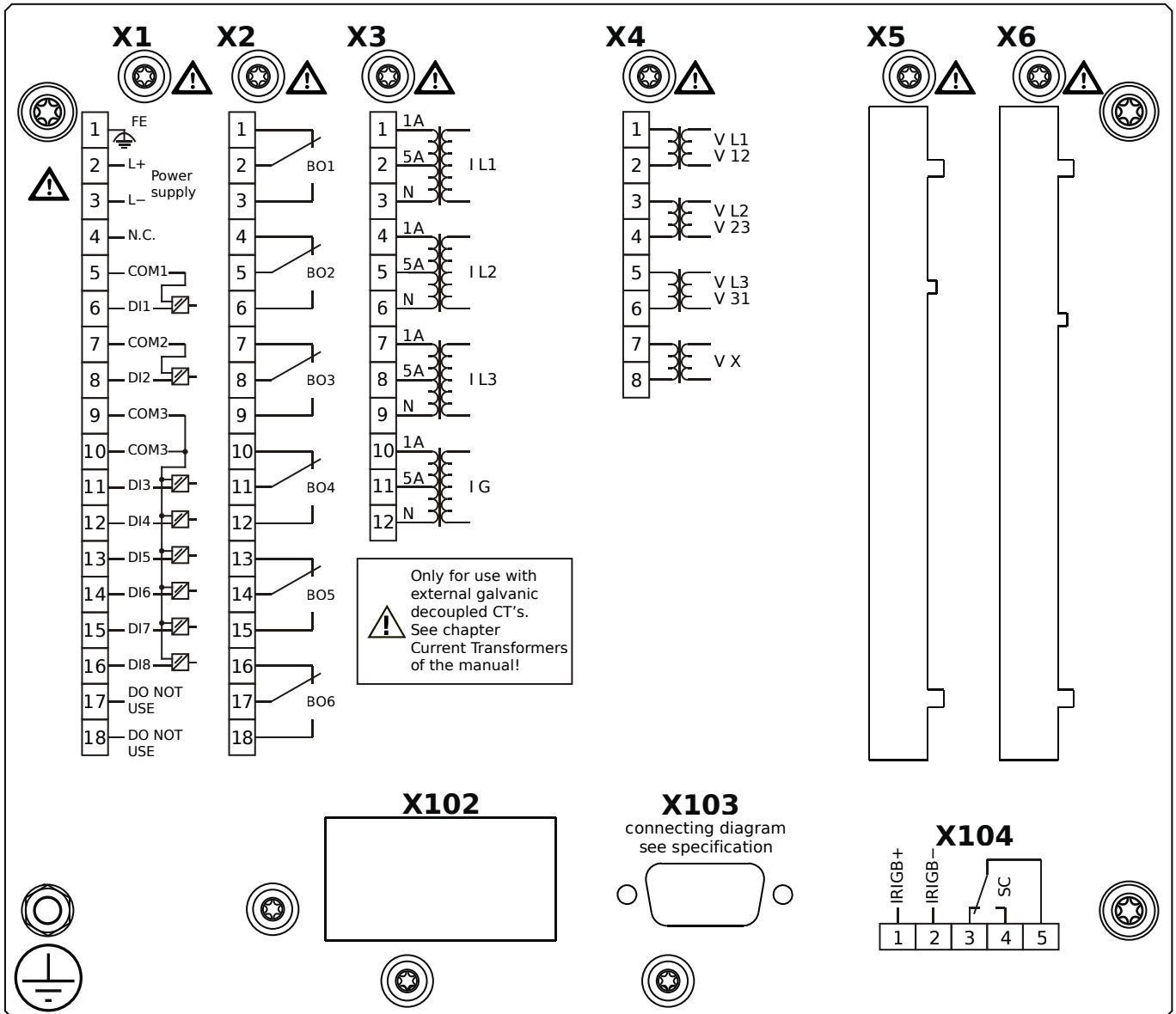

Housing B2, small display, 19" rack mounting

+ Conformal Coating (for installations in harsh environment)

- X1** – DI8-X1: Wide-range power supply unit, incl. 2 non-grouped digital inputs and 6 grouped digital inputs
- X2** – OR6: Assembly Group with 6 Output Relays (Changeover / Form C)
- X3** – TI: Standard current measuring card
- X4** – TU: Card with 4 voltage transformer measuring inputs (0 ... 800 VAC, under UL: 0 ... 600 VAC)
- X103** – Modbus RTU / IEC 60870-5-103 / DNP3.0 RTU, RS485, D-SUB
- X104** – IRIG-B00X, incl. System Contact (Supervision Contact)

MRA4-2A0BHA

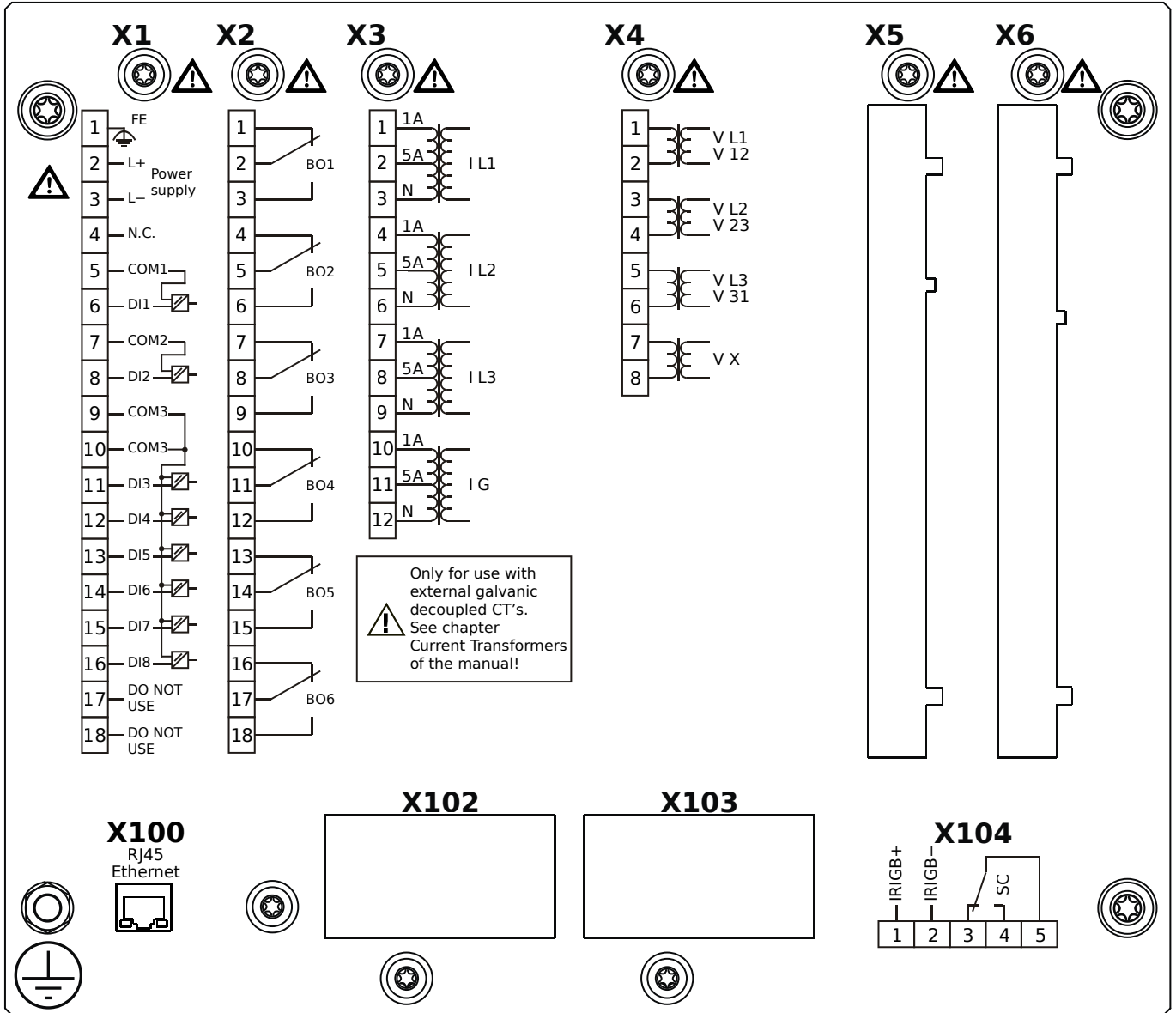

Housing B2, small display, 19" rack mounting

- X1** – DI8-X1: Wide-range power supply unit, incl. 2 non-grouped digital inputs and 6 grouped digital inputs
- X2** – OR6: Assembly Group with 6 Output Relays (Changeover / Form C)
- X3** – TI: Standard current measuring card
- X4** – TU: Card with 4 voltage transformer measuring inputs (0 ... 800 VAC, under UL: 0 ... 600 VAC)
- X100** – IEC 61850 / Modbus TCP / DNP3.0 TCP/UDP, Ethernet interface, 100 Mbit/s, RJ45 (BASE100-FX)
- X104** – IRIG-B00X, incl. System Contact (Supervision Contact)

MRA4-2A0BHB

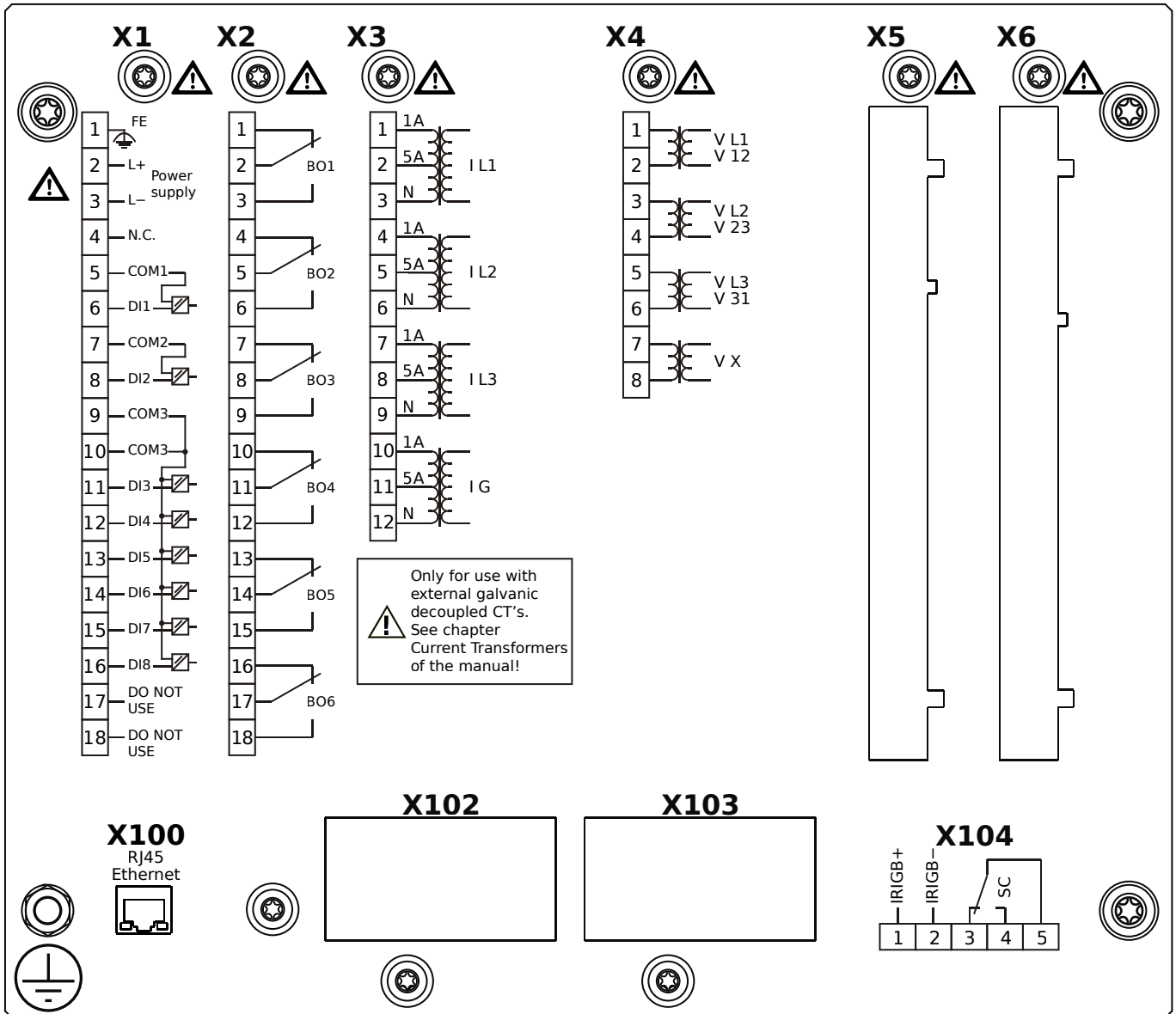

Housing B2, small display, 19" rack mounting

+ Conformal Coating (for installations in harsh environment)

- X1** – DI8-X1: Wide-range power supply unit, incl. 2 non-grouped digital inputs and 6 grouped digital inputs
- X2** – OR6: Assembly Group with 6 Output Relays (Changeover / Form C)
- X3** – TI: Standard current measuring card
- X4** – TU: Card with 4 voltage transformer measuring inputs (0 ... 800 VAC, under UL: 0 ... 600 VAC)
- X100** – IEC 61850 / Modbus TCP / DNP3.0 TCP/UDP, Ethernet interface, 100 Mbit/s, RJ45 (BASE100-FX)
- X104** – IRIG-B00X, incl. System Contact (Supervision Contact)

MRA4-2A0BIA

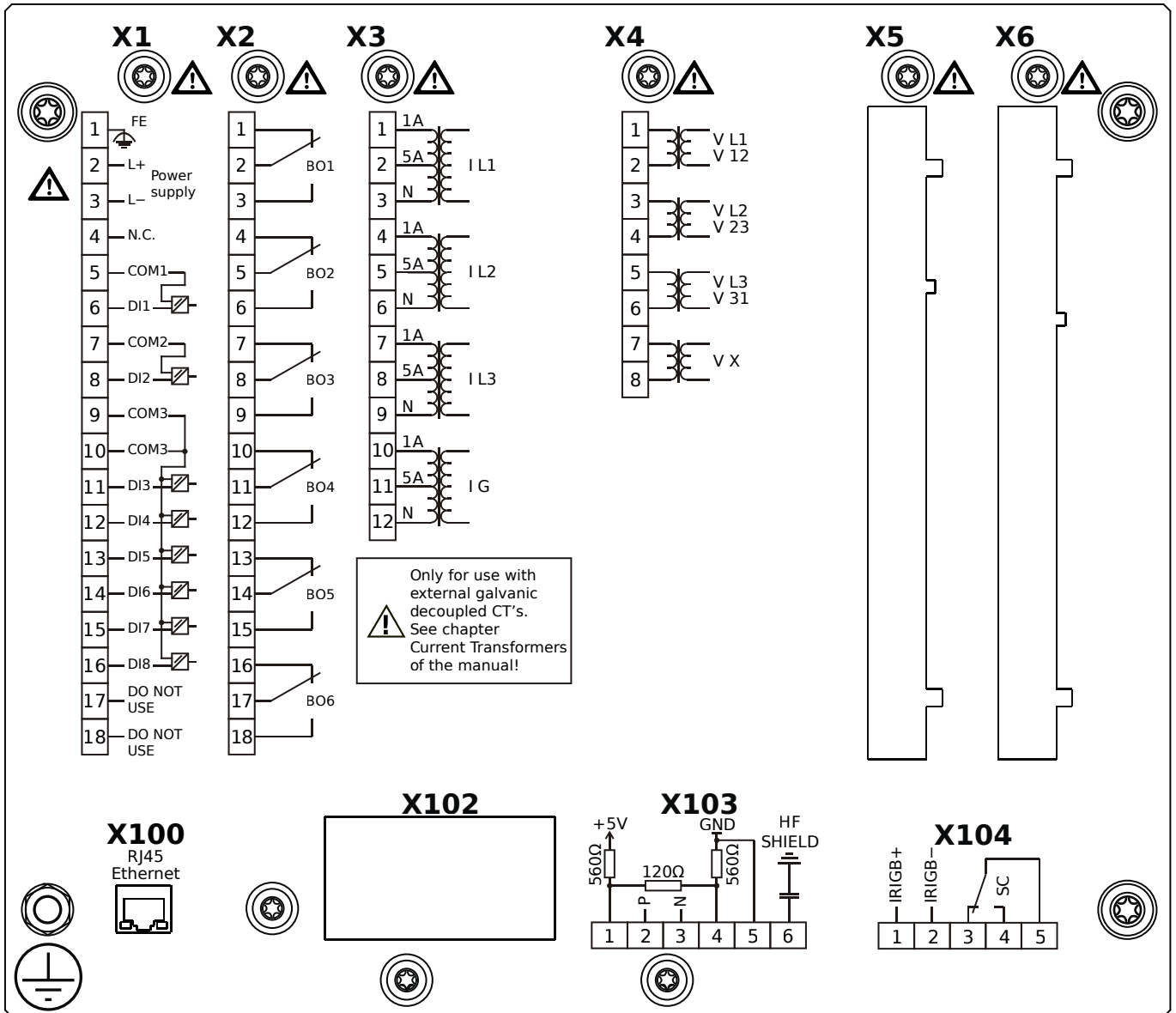

Housing B2, small display, 19" rack mounting

- X1** – DI8-X1: Wide-range power supply unit, incl. 2 non-grouped digital inputs and 6 grouped digital inputs
- X2** – OR6: Assembly Group with 6 Output Relays (Changeover / Form C)
- X3** – TI: Standard current measuring card
- X4** – TU: Card with 4 voltage transformer measuring inputs (0 ... 800 VAC, under UL: 0 ... 600 VAC)
- X100** – Modbus TCP / DNP3.0 TCP/UDP, Ethernet interface, 100 Mbit/s, RJ45 (BASE100-FX)
- X103** – IEC 60870-5-103 / Modbus RTU / DNP3.0 RTU, RS485, Terminals
- X104** – IRIG-B00X, incl. System Contact (Supervision Contact)

MRA4-2A0BIB

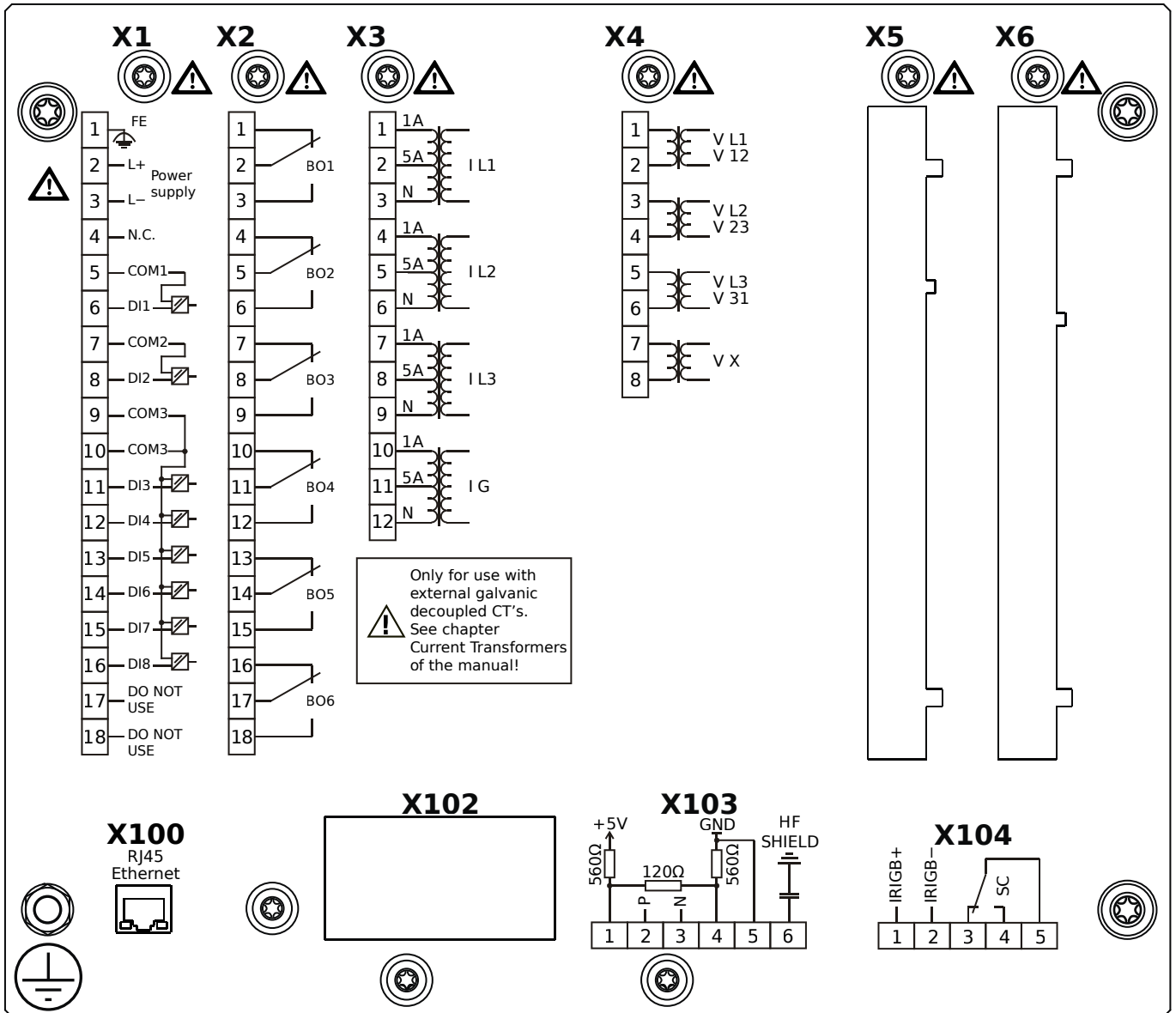

Housing B2, small display, 19" rack mounting

+ Conformal Coating (for installations in harsh environment)

- X1** – DI8-X1: Wide-range power supply unit, incl. 2 non-grouped digital inputs and 6 grouped digital inputs
- X2** – OR6: Assembly Group with 6 Output Relays (Changeover / Form C)
- X3** – TI: Standard current measuring card
- X4** – TU: Card with 4 voltage transformer measuring inputs (0 ... 800 VAC, under UL: 0 ... 600 VAC)
- X100** – Modbus TCP / DNP3.0 TCP/UDP, Ethernet interface, 100 Mbit/s, RJ45 (BASE100-FX)
- X103** – IEC 60870-5-103 / Modbus RTU / DNP3.0 RTU, RS485, Terminals
- X104** – IRIG-B00X, incl. System Contact (Supervision Contact)

MRA4-2A0BKA

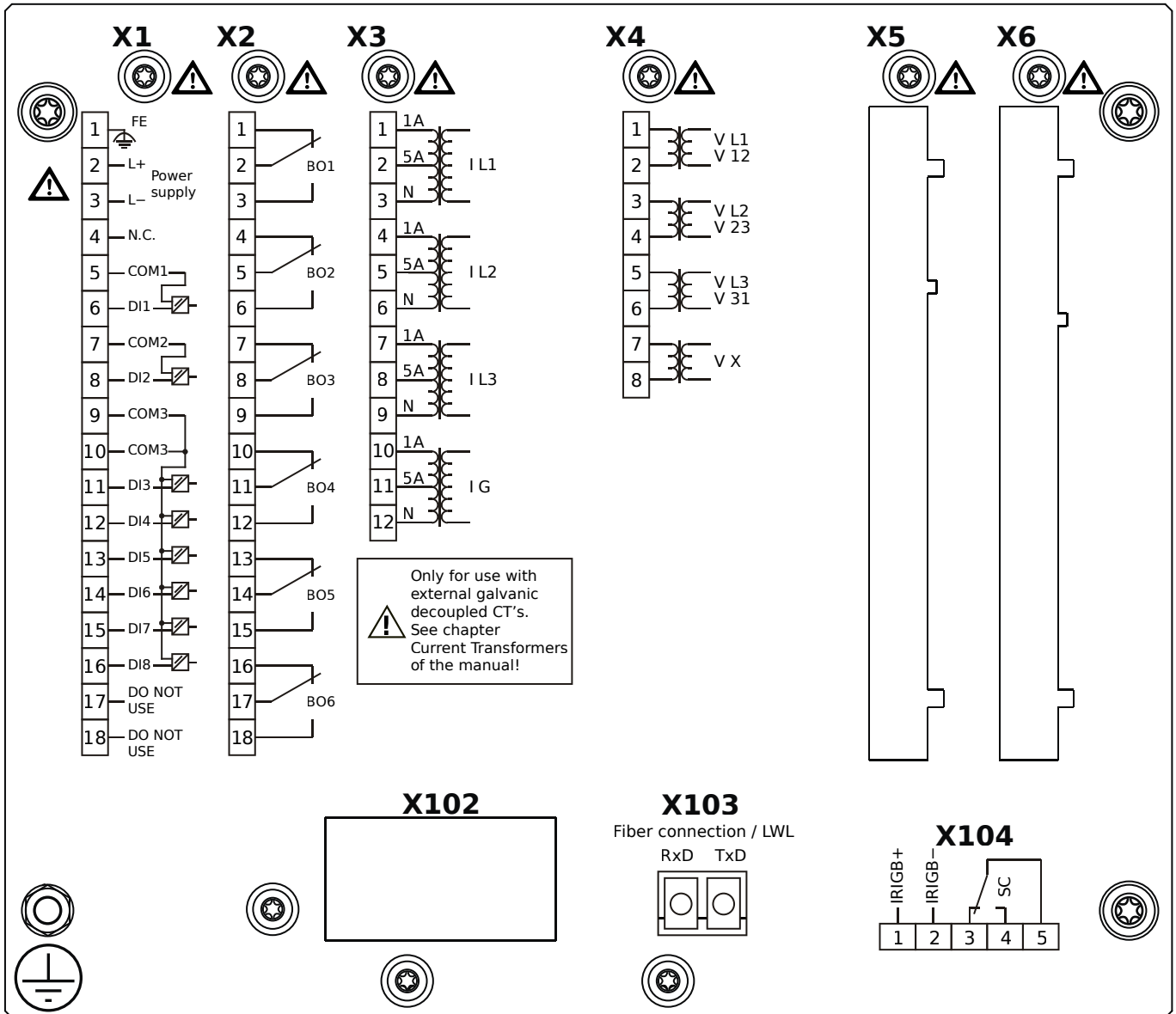

Housing B2, small display, 19" rack mounting

- X1** – DI8-X1: Wide-range power supply unit, incl. 2 non-grouped digital inputs and 6 grouped digital inputs
- X2** – OR6: Assembly Group with 6 Output Relays (Changeover / Form C)
- X3** – TI: Standard current measuring card
- X4** – TU: Card with 4 voltage transformer measuring inputs (0 ... 800 VAC, under UL: 0 ... 600 VAC)
- X103** – IEC 61850 / Modbus TCP / DNP3.0 TCP/UDP, Fiber optics interface, LC Connector
- X104** – IRIG-B00X, incl. System Contact (Supervision Contact)

MRA4-2A0BKB

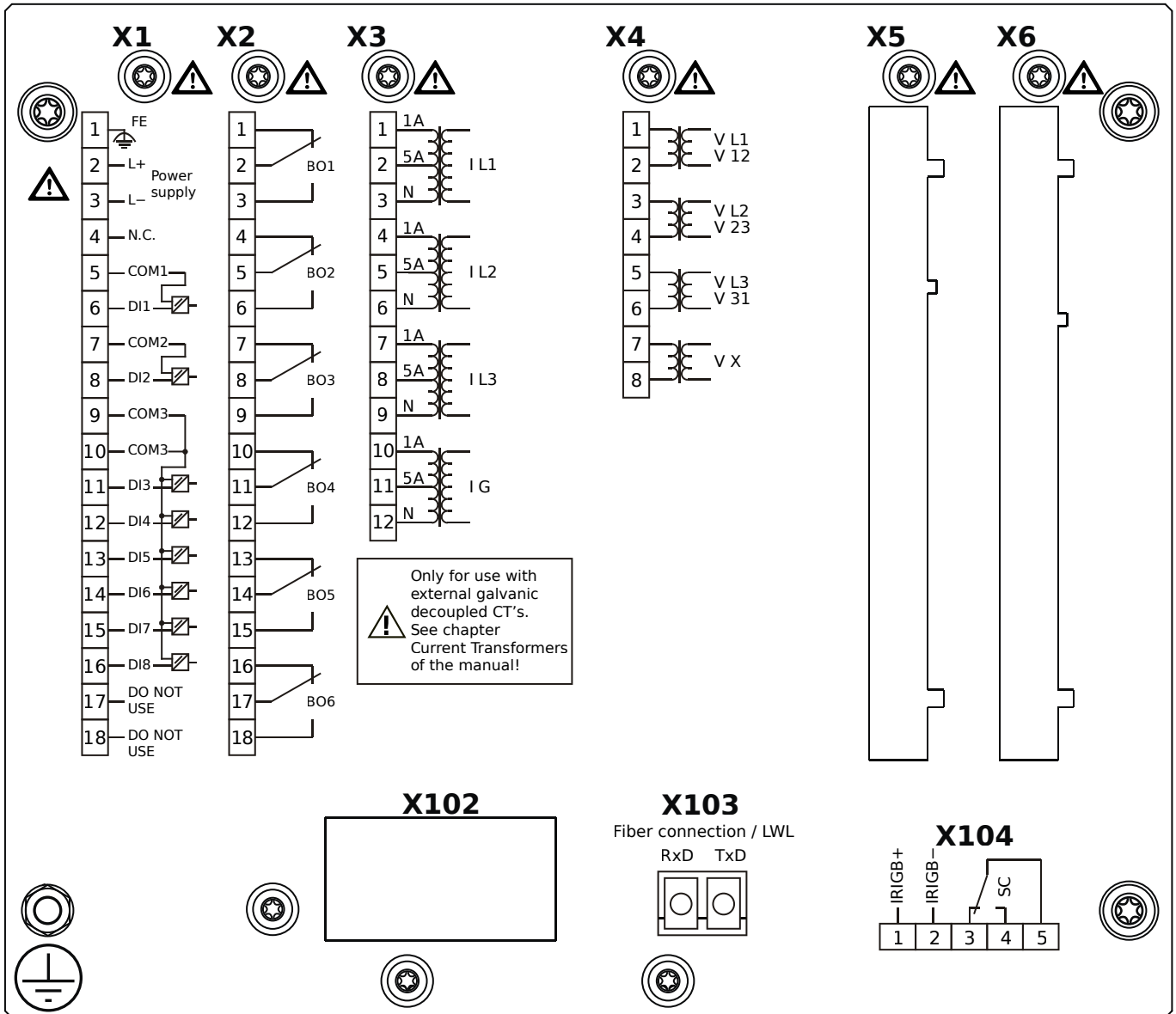

Housing B2, small display, 19" rack mounting

+ Conformal Coating (for installations in harsh environment)

- X1** – DI8-X1: Wide-range power supply unit, incl. 2 non-grouped digital inputs and 6 grouped digital inputs
- X2** – OR6: Assembly Group with 6 Output Relays (Changeover / Form C)
- X3** – TI: Standard current measuring card
- X4** – TU: Card with 4 voltage transformer measuring inputs (0 ... 800 VAC, under UL: 0 ... 600 VAC)
- X103** – IEC 61850 / Modbus TCP / DNP3.0 TCP/UDP, Fiber optics interface, LC Connector
- X104** – IRIG-B00X, incl. System Contact (Supervision Contact)

MRA4-2A0BLA

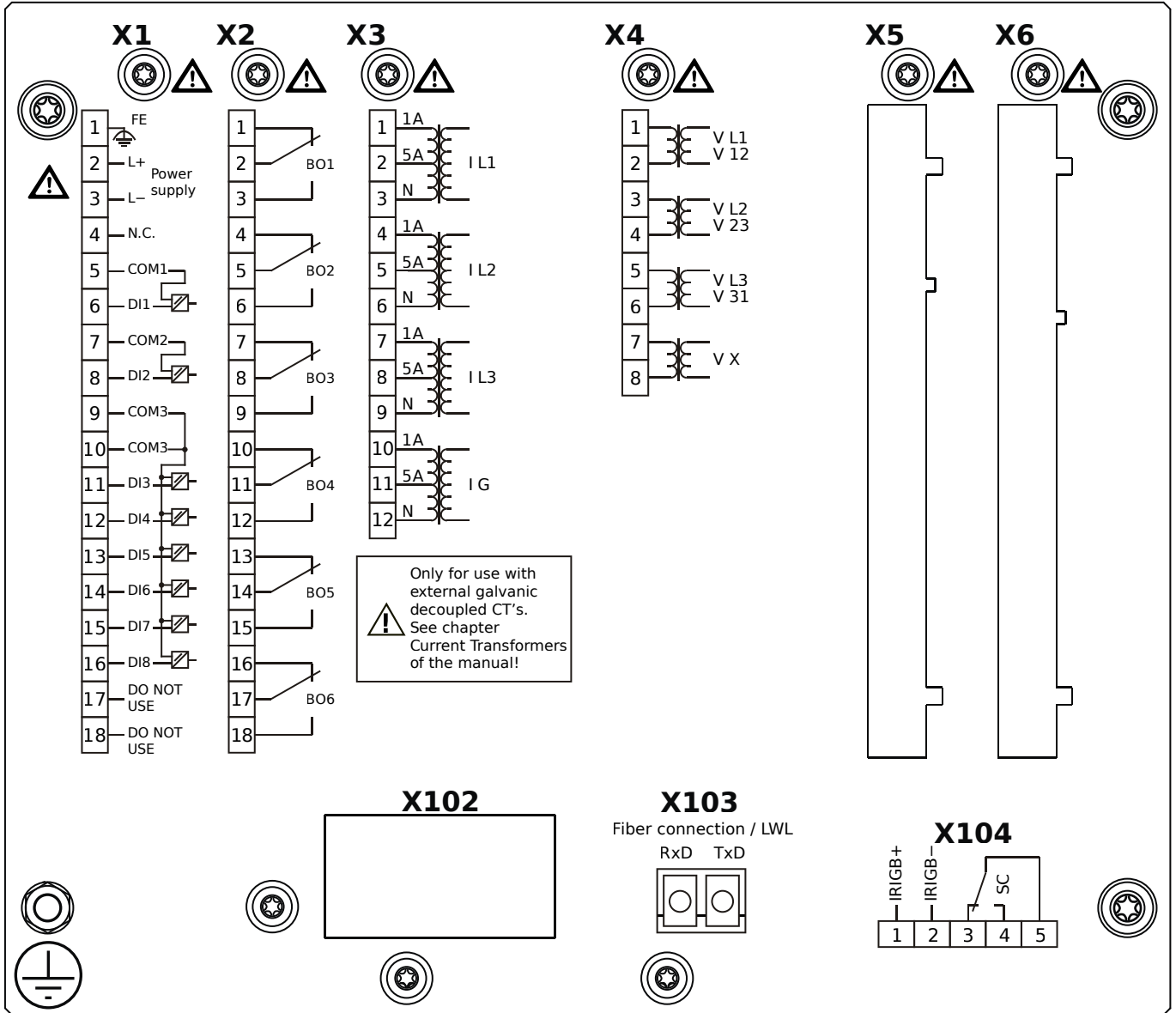

Housing B2, small display, 19" rack mounting

- X1** – DI8-X1: Wide-range power supply unit, incl. 2 non-grouped digital inputs and 6 grouped digital inputs
- X2** – OR6: Assembly Group with 6 Output Relays (Changeover / Form C)
- X3** – TI: Standard current measuring card
- X4** – TU: Card with 4 voltage transformer measuring inputs (0 ... 800 VAC, under UL: 0 ... 600 VAC)
- X103** – Modbus TCP / DNP3.0 TCP/UDP, Fiber optics interface, LC Connector
- X104** – IRIG-B00X, incl. System Contact (Supervision Contact)

MRA4-2A0BLB

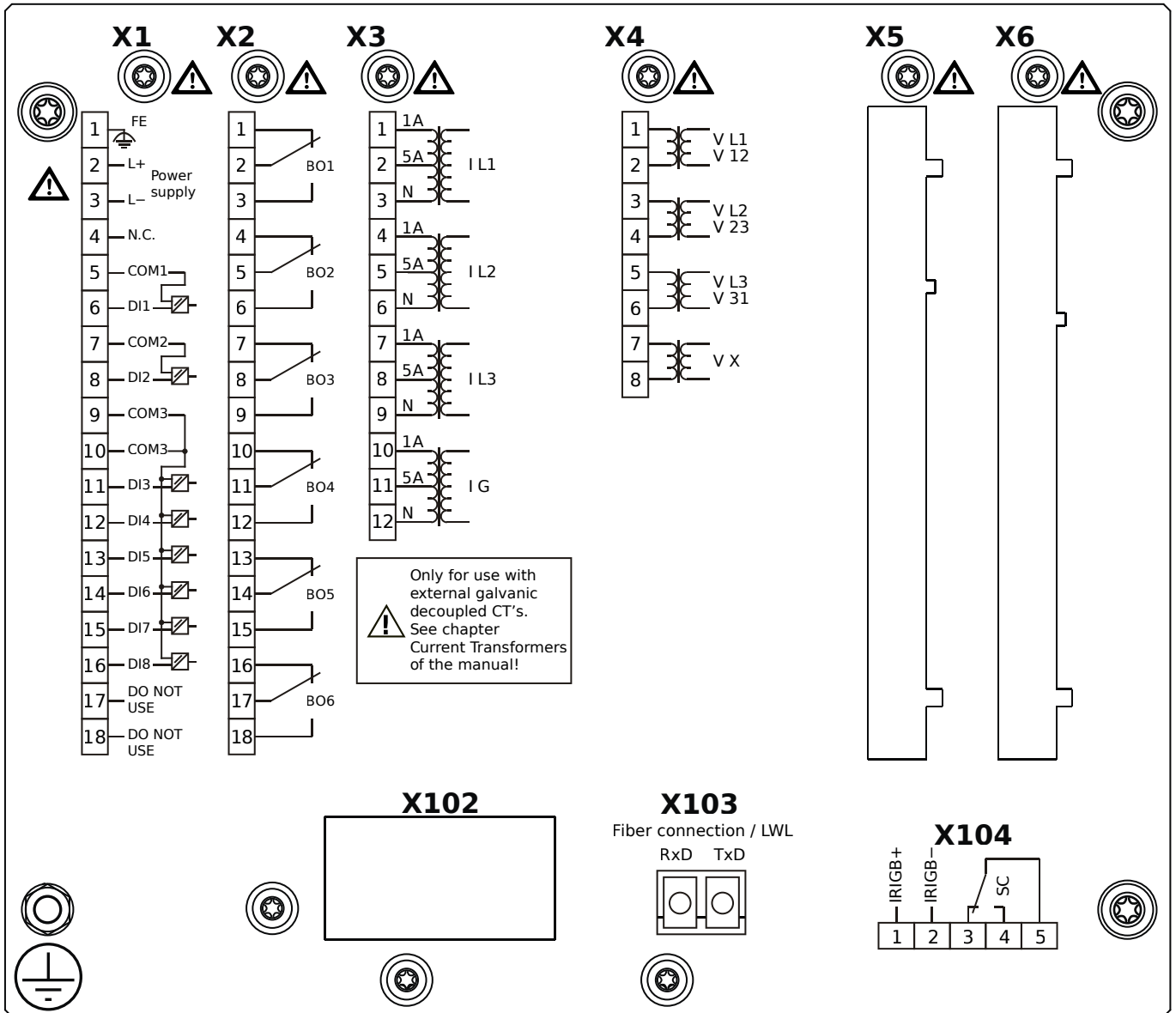

Housing B2, small display, 19" rack mounting

+ Conformal Coating (for installations in harsh environment)

- X1** – DI8-X1: Wide-range power supply unit, incl. 2 non-grouped digital inputs and 6 grouped digital inputs
- X2** – OR6: Assembly Group with 6 Output Relays (Changeover / Form C)
- X3** – TI: Standard current measuring card
- X4** – TU: Card with 4 voltage transformer measuring inputs (0 ... 800 VAC, under UL: 0 ... 600 VAC)
- X103** – Modbus TCP / DNP3.0 TCP/UDP, Fiber optics interface, LC Connector
- X104** – IRIG-B00X, incl. System Contact (Supervision Contact)

MRA4-2A0BTA

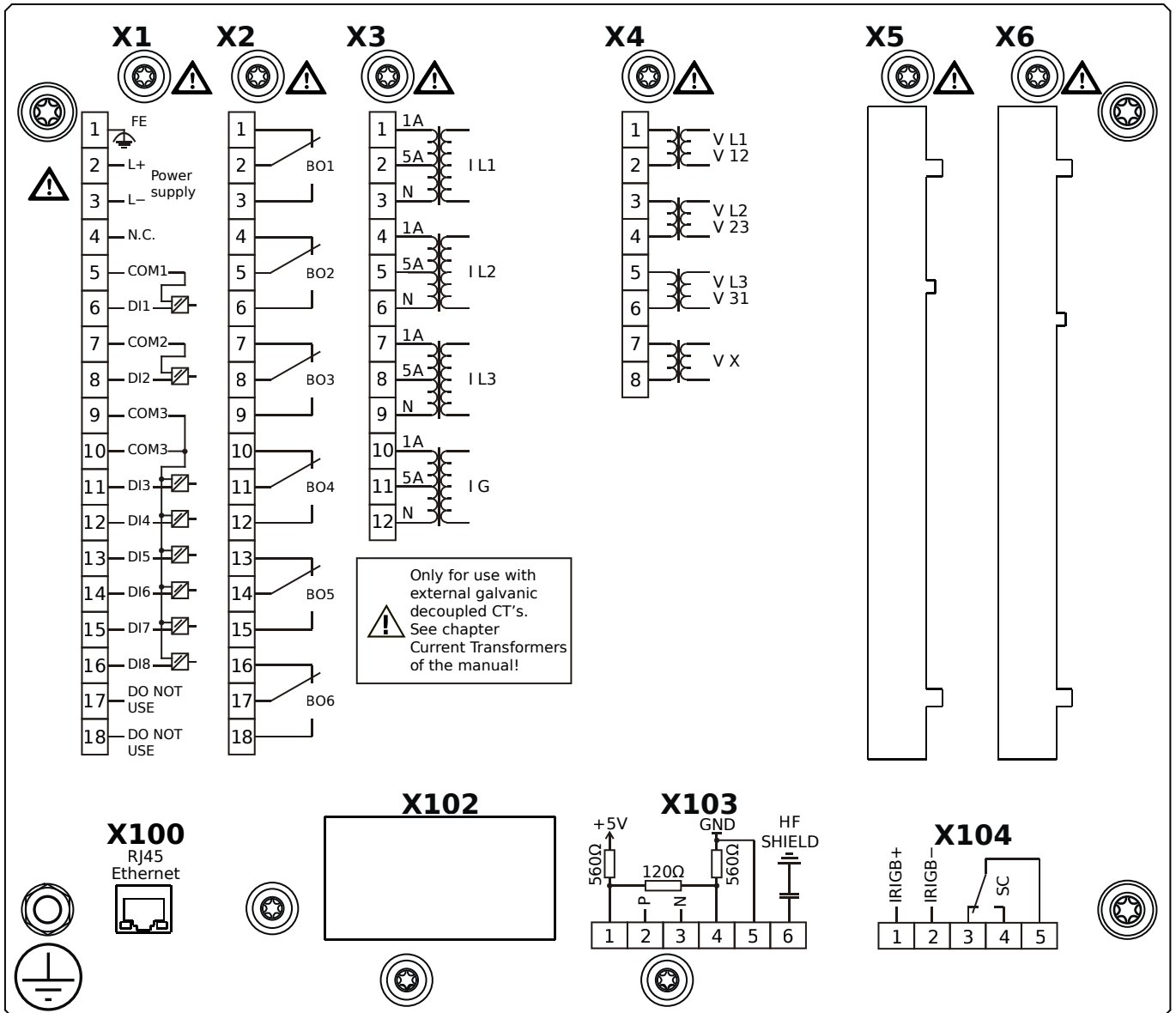

Housing B2, small display, 19" rack mounting

- X1** – DI8-X1: Wide-range power supply unit, incl. 2 non-grouped digital inputs and 6 grouped digital inputs
- X2** – OR6: Assembly Group with 6 Output Relays (Changeover / Form C)
- X3** – TI: Standard current measuring card
- X4** – TU: Card with 4 voltage transformer measuring inputs (0 ... 800 VAC, under UL: 0 ... 600 VAC)
- X100** – IEC 61850 / Modbus TCP / DNP3.0 TCP/UDP, Ethernet interface, 100 Mbit/s, RJ45 (BASE100-FX)
- X103** – IEC 60870-5-103 / Modbus RTU / DNP3.0 RTU, RS485, Terminals
- X104** – IRIG-B00X, incl. System Contact (Supervision Contact)

MRA4-2A0BTB

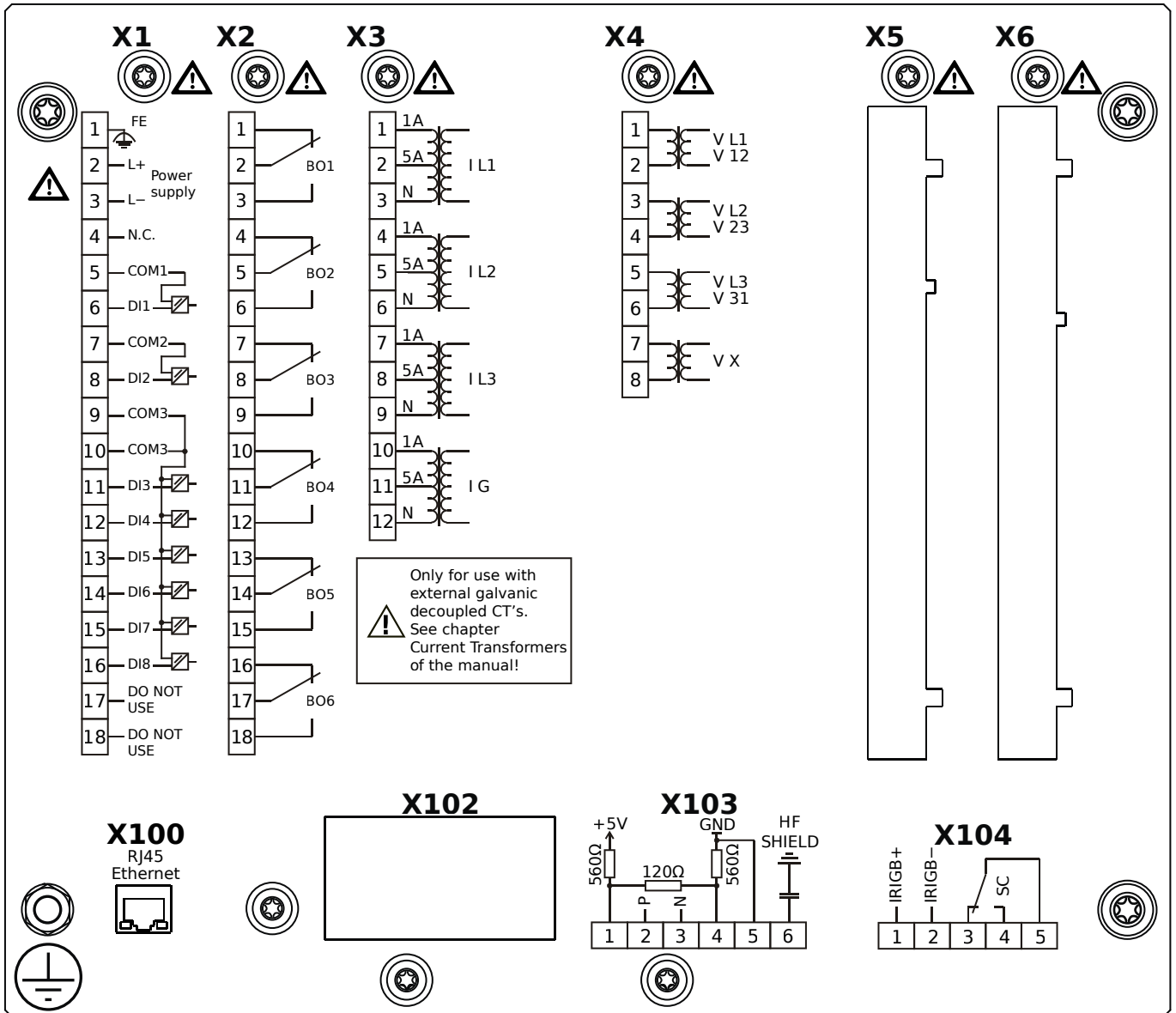

Housing B2, small display, 19" rack mounting

+ Conformal Coating (for installations in harsh environment)

- X1** – DI8-X1: Wide-range power supply unit, incl. 2 non-grouped digital inputs and 6 grouped digital inputs
- X2** – OR6: Assembly Group with 6 Output Relays (Changeover / Form C)
- X3** – TI: Standard current measuring card
- X4** – TU: Card with 4 voltage transformer measuring inputs (0 ... 800 VAC, under UL: 0 ... 600 VAC)
- X100** – IEC 61850 / Modbus TCP / DNP3.0 TCP/UDP, Ethernet interface, 100 Mbit/s, RJ45 (BASE100-FX)
- X103** – IEC 60870-5-103 / Modbus RTU / DNP3.0 RTU, RS485, Terminals
- X104** – IRIG-B00X, incl. System Contact (Supervision Contact)

MRA4-2A1AAA

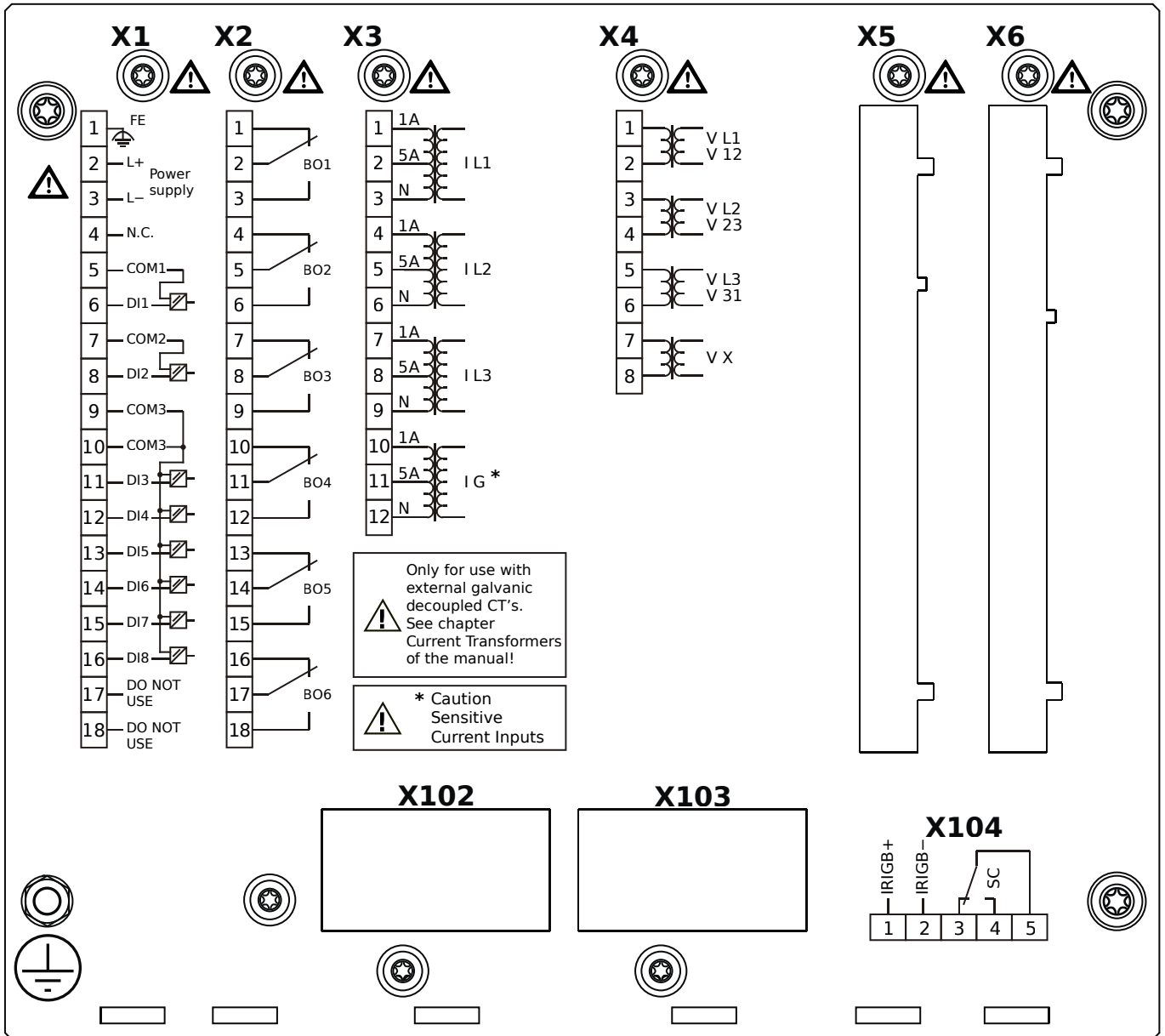

Housing B2, small display, door mounting

- X1** – DI8-X1: Wide-range power supply unit, incl. 2 non-grouped digital inputs and 6 grouped digital inputs
- X2** – OR6: Assembly Group with 6 Output Relays (Changeover / Form C)
- X3** – TIs: Standard phase current measuring card and sensitive ground current measuring
- X4** – TU: Card with 4 voltage transformer measuring inputs (0 ... 800 VAC, under UL: 0 ... 600 VAC)
- X104** – IRIG-B00X, incl. System Contact (Supervision Contact)

MRA4-2A1AAB

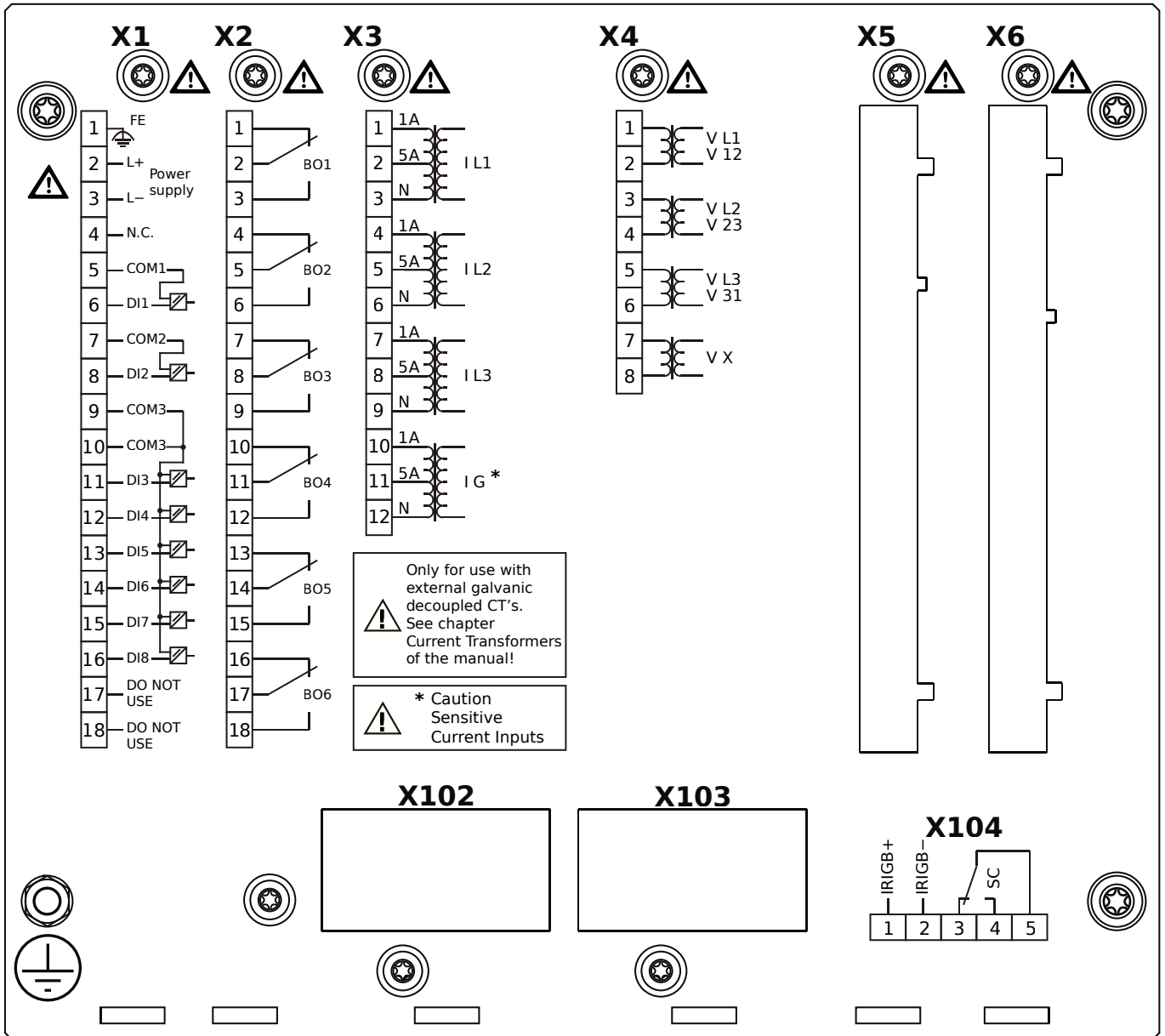

Housing B2, small display, door mounting

+ Conformal Coating (for installations in harsh environment)

- X1** – DI8-X1: Wide-range power supply unit, incl. 2 non-grouped digital inputs and 6 grouped digital inputs
- X2** – OR6: Assembly Group with 6 Output Relays (Changeover / Form C)
- X3** – TIs: Standard phase current measuring card and sensitive ground current measuring
- X4** – TU: Card with 4 voltage transformer measuring inputs (0 ... 800 VAC, under UL: 0 ... 600 VAC)
- X104** – IRIG-B00X, incl. System Contact (Supervision Contact)

MRA4-2A1ABA

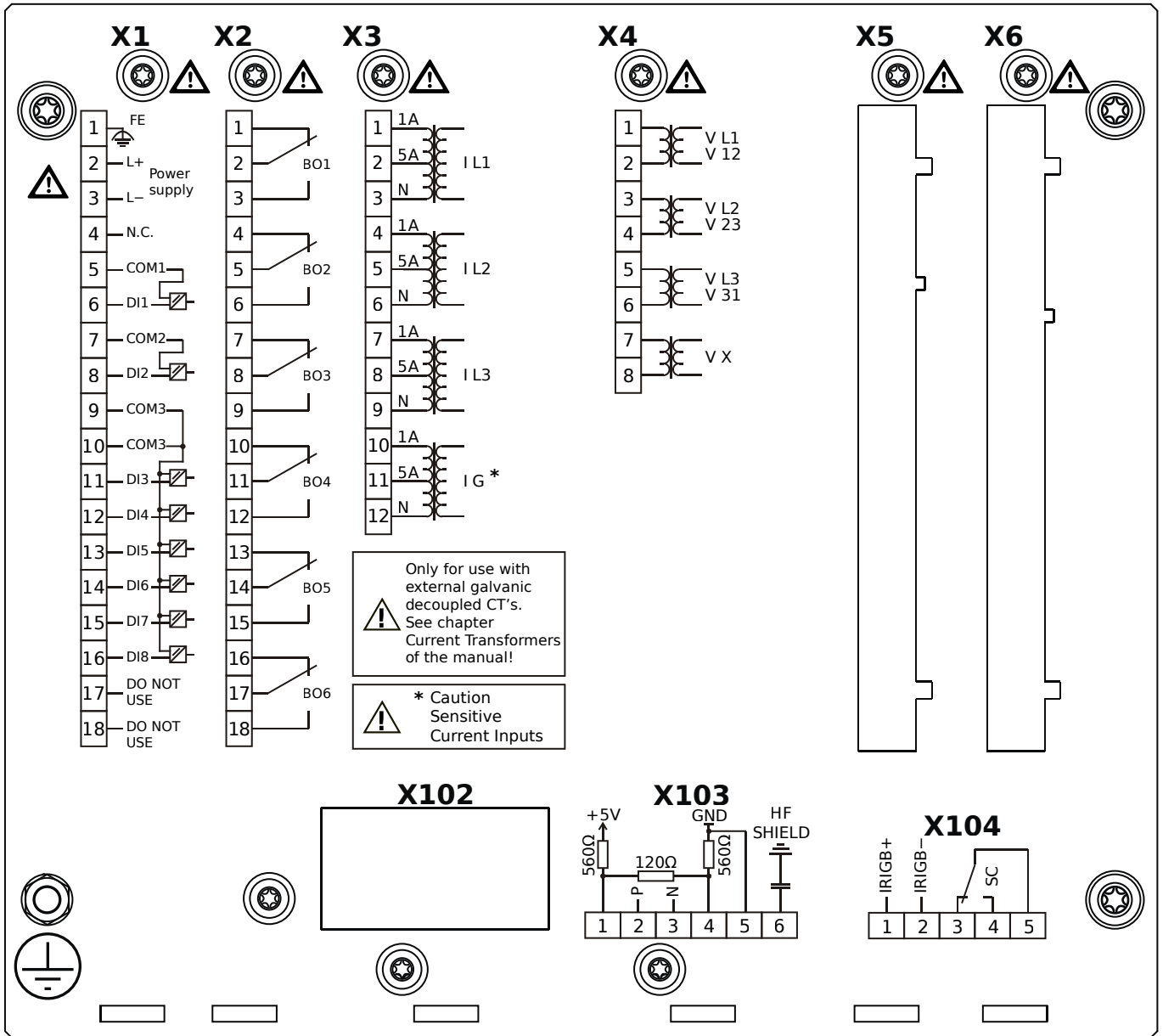

Housing B2, small display, door mounting

- X1** – DI8-X1: Wide-range power supply unit, incl. 2 non-grouped digital inputs and 6 grouped digital inputs
- X2** – OR6: Assembly Group with 6 Output Relays (Changeover / Form C)
- X3** – TIs: Standard phase current measuring card and sensitive ground current measuring
- X4** – TU: Card with 4 voltage transformer measuring inputs (0 ... 800 VAC, under UL: 0 ... 600 VAC)
- X103** – Modbus RTU / IEC 60870-5-103 / DNP3.0 RTU, RS485, Terminals
- X104** – IRIG-B00X, incl. System Contact (Supervision Contact)

MRA4-2A1ABB

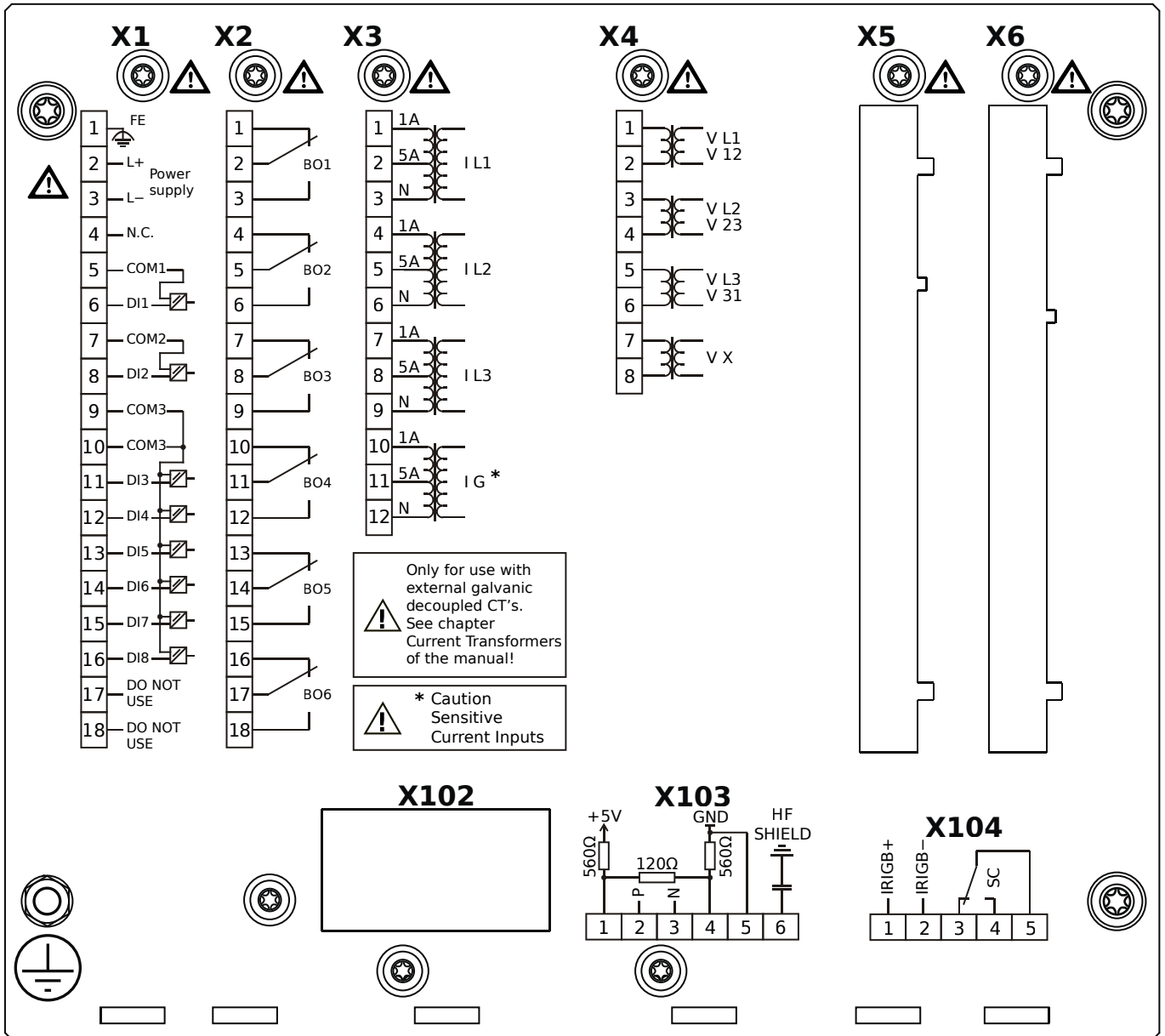

Housing B2, small display, door mounting

+ Conformal Coating (for installations in harsh environment)

- X1** – DI8-X1: Wide-range power supply unit, incl. 2 non-grouped digital inputs and 6 grouped digital inputs
- X2** – OR6: Assembly Group with 6 Output Relays (Changeover / Form C)
- X3** – TIs: Standard phase current measuring card and sensitive ground current measuring
- X4** – TU: Card with 4 voltage transformer measuring inputs (0 ... 800 VAC, under UL: 0 ... 600 VAC)
- X103** – Modbus RTU / IEC 60870-5-103 / DNP3.0 RTU, RS485, Terminals
- X104** – IRIG-B00X, incl. System Contact (Supervision Contact)

MRA4-2A1ACA

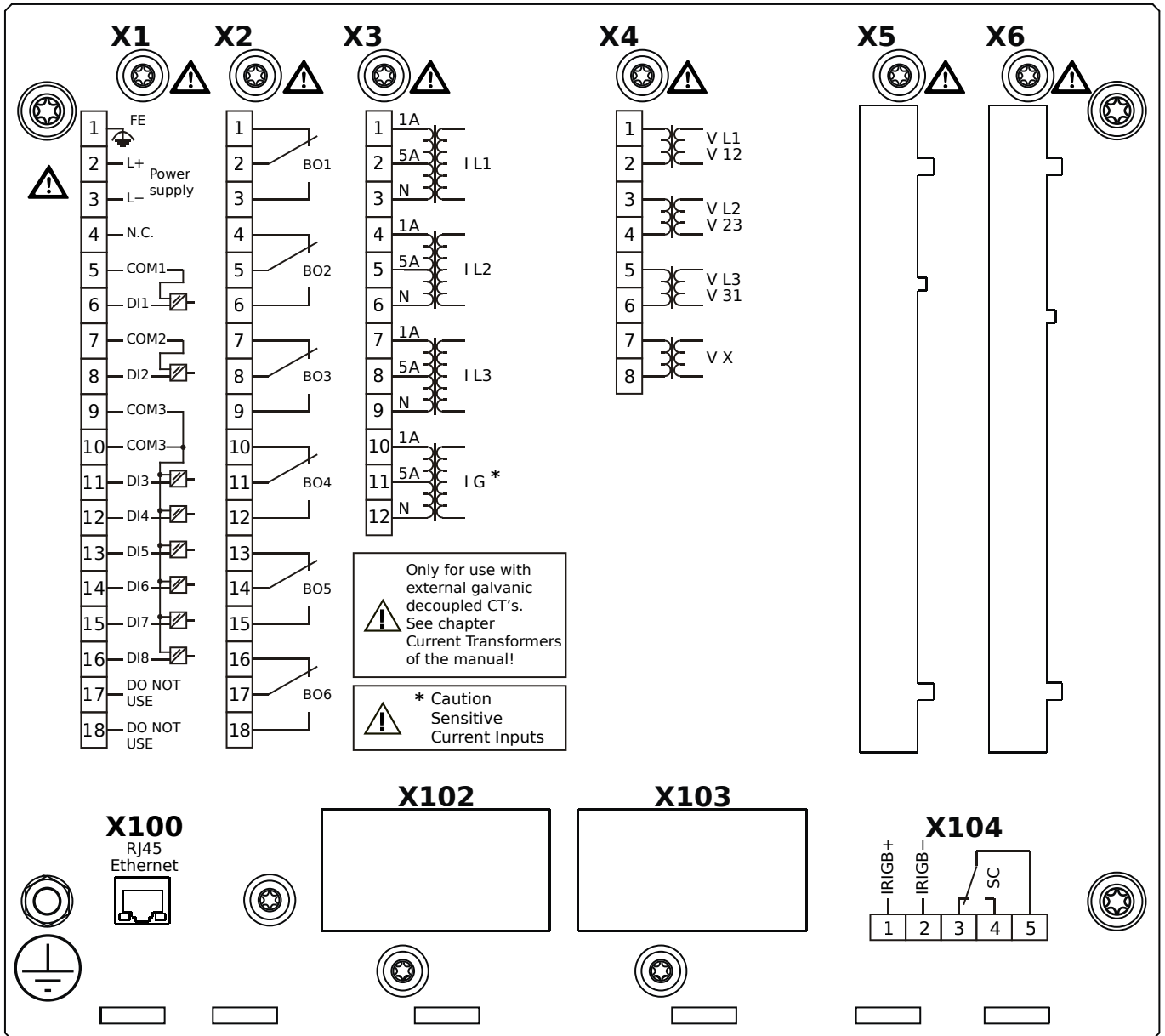

Housing B2, small display, door mounting

- X1** – DI8-X1: Wide-range power supply unit, incl. 2 non-grouped digital inputs and 6 grouped digital inputs
- X2** – OR6: Assembly Group with 6 Output Relays (Changeover / Form C)
- X3** – TIs: Standard phase current measuring card and sensitive ground current measuring
- X4** – TU: Card with 4 voltage transformer measuring inputs (0 ... 800 VAC, under UL: 0 ... 600 VAC)
- X100** – Modbus TCP / DNP3.0 TCP/UDP, Ethernet interface, 100 Mbit/s, RJ45 (BASE100-FX)
- X104** – IRIG-B00X, incl. System Contact (Supervision Contact)

MRA4-2A1ACB

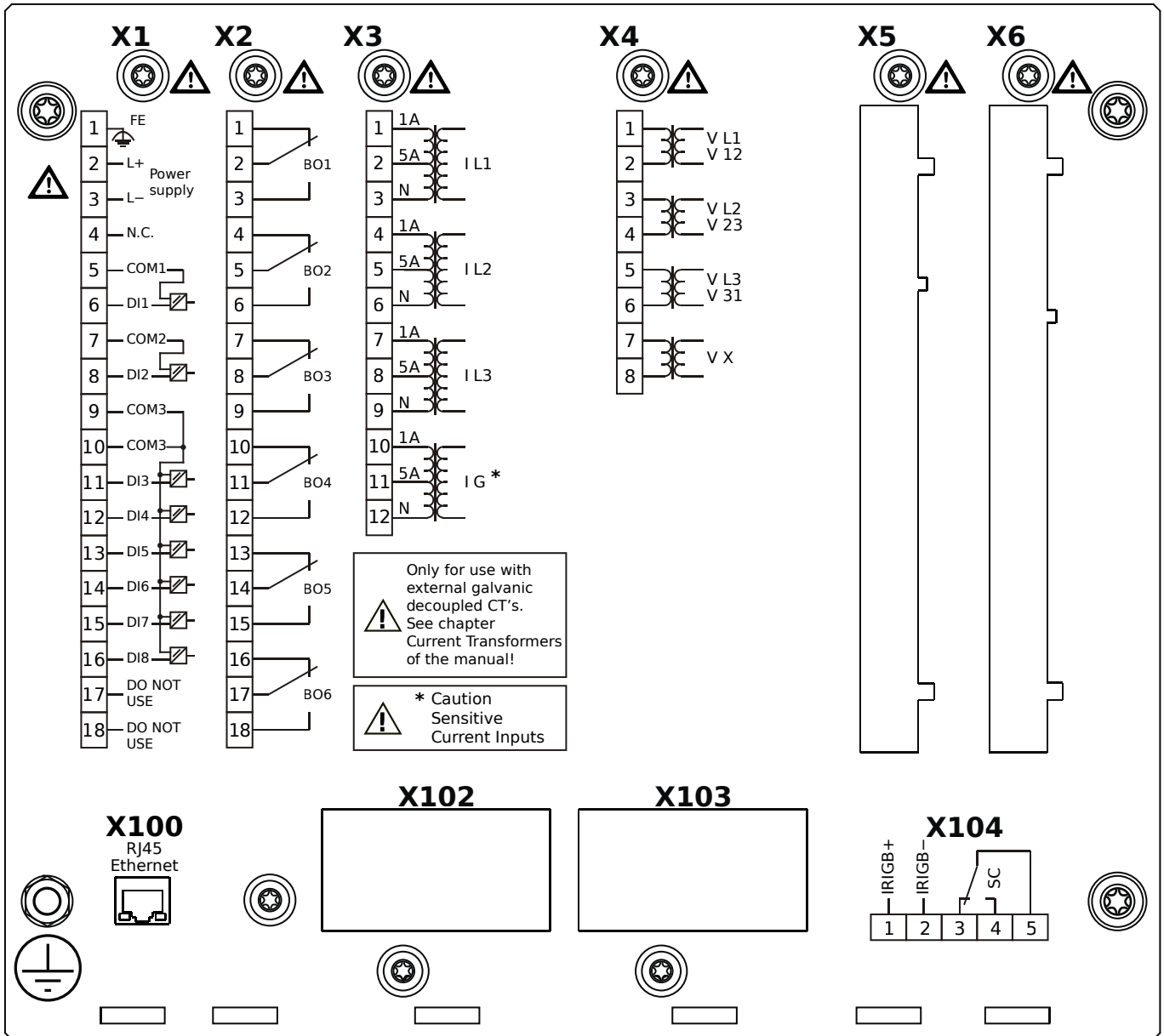

Housing B2, small display, door mounting

+ Conformal Coating (for installations in harsh environment)

- X1** – DI8-X1: Wide-range power supply unit, incl. 2 non-grouped digital inputs and 6 grouped digital inputs
- X2** – OR6: Assembly Group with 6 Output Relays (Changeover / Form C)
- X3** – TIs: Standard phase current measuring card and sensitive ground current measuring
- X4** – TU: Card with 4 voltage transformer measuring inputs (0 ... 800 VAC, under UL: 0 ... 600 VAC)
- X100** – Modbus TCP / DNP3.0 TCP/UDP, Ethernet interface, 100 Mbit/s, RJ45 (BASE100-FX)
- X104** – IRIG-B00X, incl. System Contact (Supervision Contact)

MRA4-2A1ADA

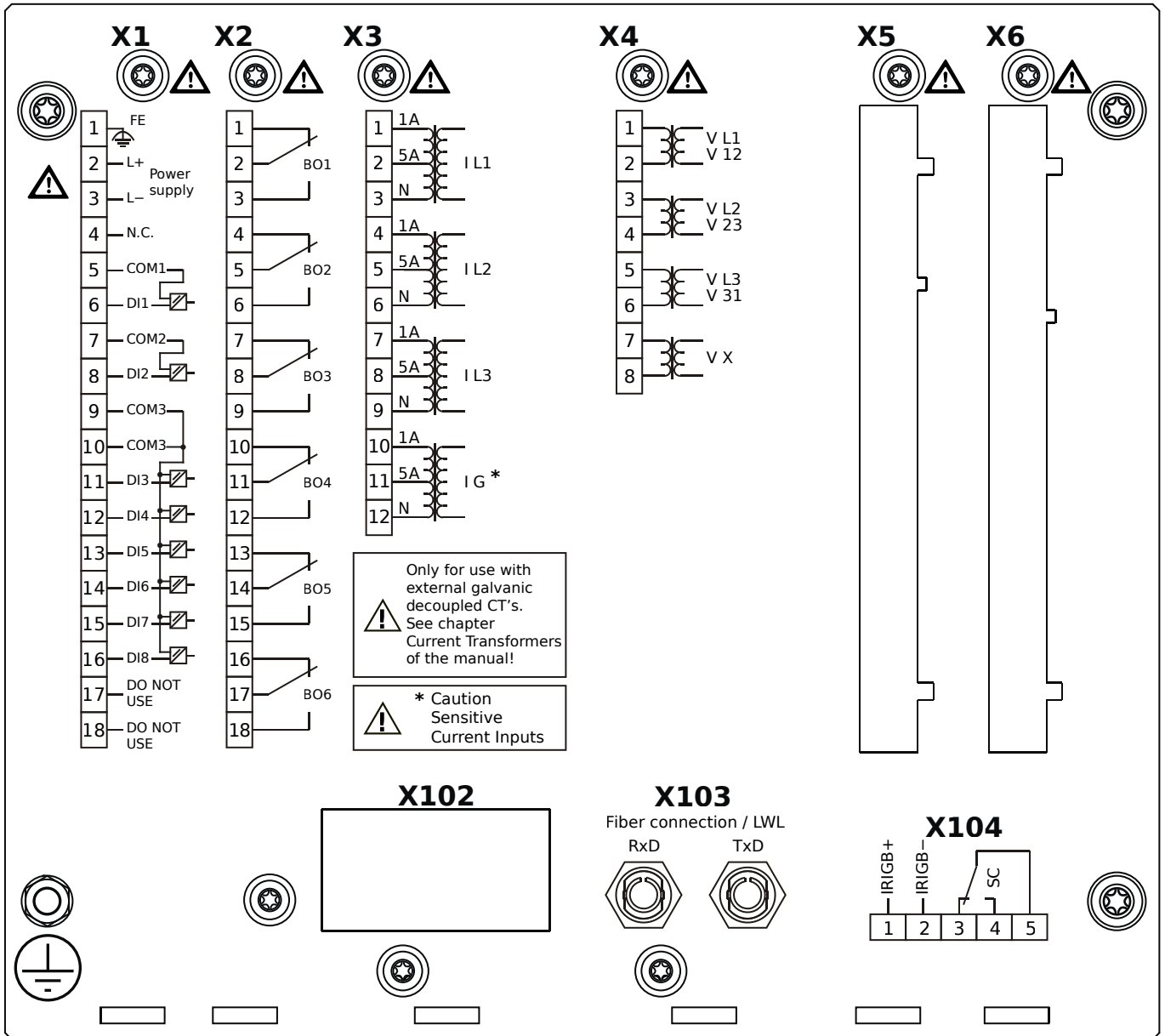

Housing B2, small display, door mounting

- X1** – DI8-X1: Wide-range power supply unit, incl. 2 non-grouped digital inputs and 6 grouped digital inputs
- X2** – OR6: Assembly Group with 6 Output Relays (Changeover / Form C)
- X3** – TIs: Standard phase current measuring card and sensitive ground current measuring
- X4** – TU: Card with 4 voltage transformer measuring inputs (0 ... 800 VAC, under UL: 0 ... 600 VAC)
- X103** – Profibus-DP, Fiber optics interface, ST Connector
- X104** – IRIG-B00X, incl. System Contact (Supervision Contact)

MRA4-2A1ADB

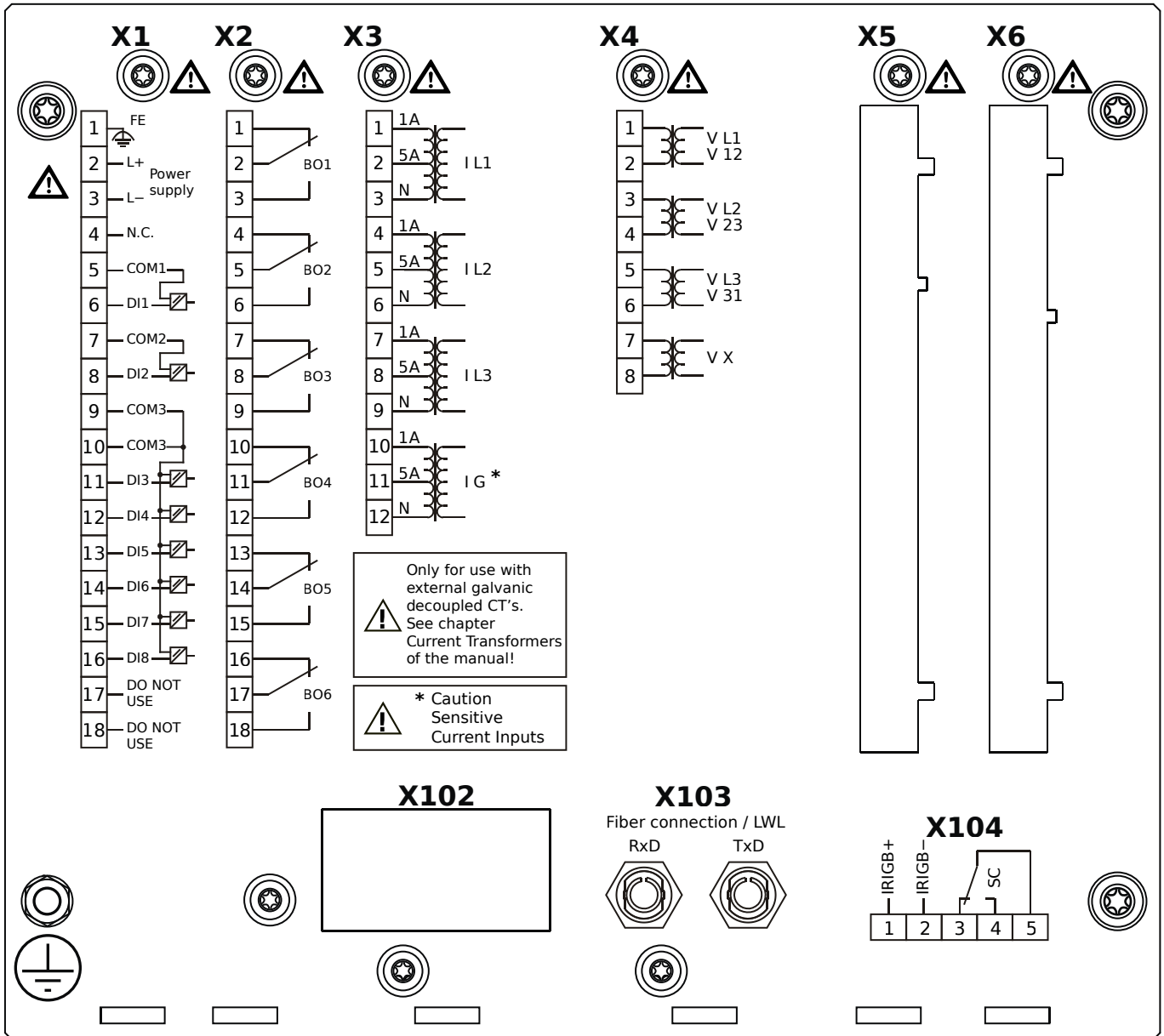

Housing B2, small display, door mounting

+ Conformal Coating (for installations in harsh environment)

- X1** – DI8-X1: Wide-range power supply unit, incl. 2 non-grouped digital inputs and 6 grouped digital inputs
- X2** – OR6: Assembly Group with 6 Output Relays (Changeover / Form C)
- X3** – TIs: Standard phase current measuring card and sensitive ground current measuring
- X4** – TU: Card with 4 voltage transformer measuring inputs (0 ... 800 VAC, under UL: 0 ... 600 VAC)
- X103** – Profibus-DP, Fiber optics interface, ST Connector
- X104** – IRIG-B00X, incl. System Contact (Supervision Contact)

MRA4-2A1AEA

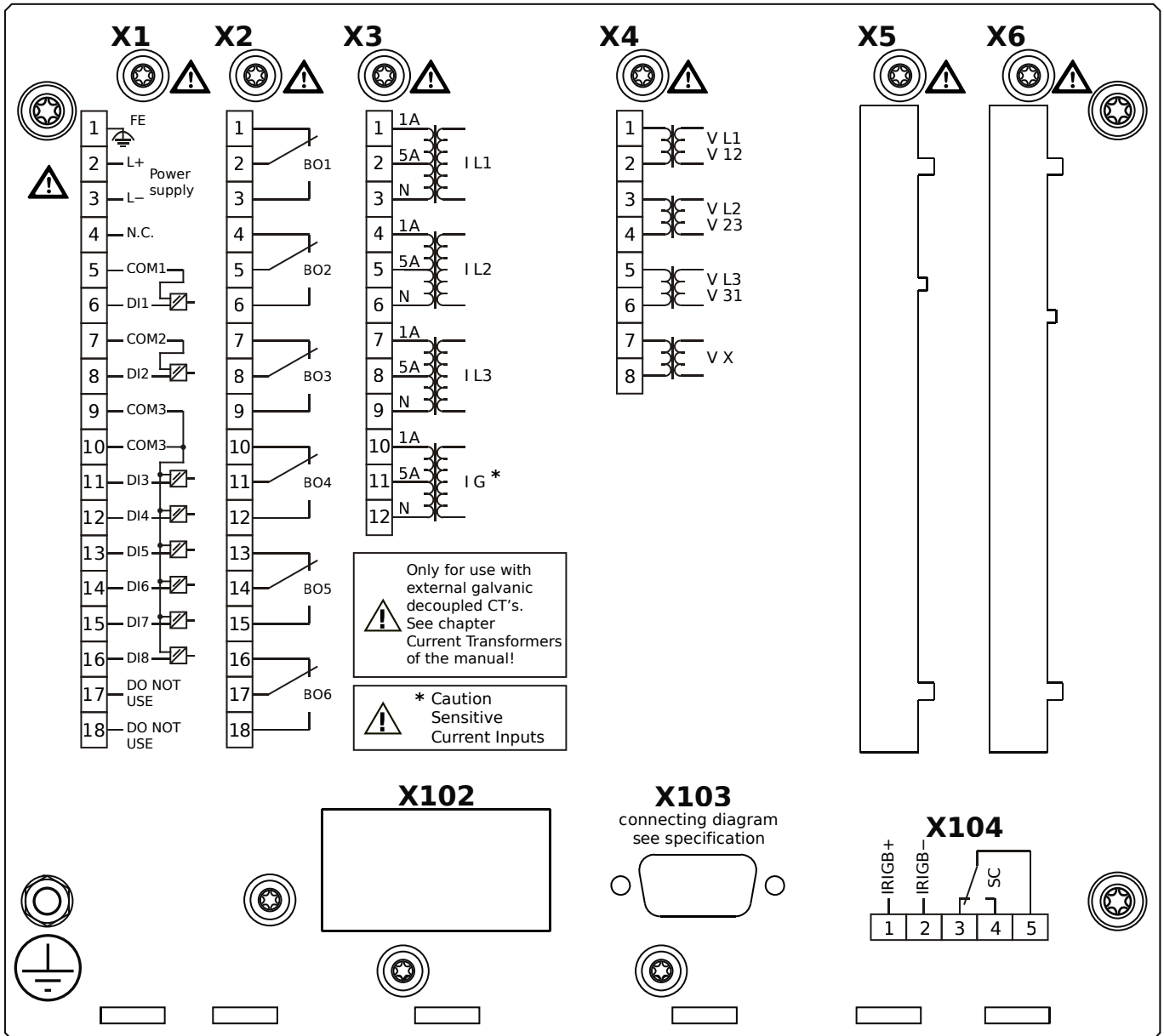

Housing B2, small display, door mounting

- X1** – DI8-X1: Wide-range power supply unit, incl. 2 non-grouped digital inputs and 6 grouped digital inputs
- X2** – OR6: Assembly Group with 6 Output Relays (Changeover / Form C)
- X3** – TIs: Standard phase current measuring card and sensitive ground current measuring
- X4** – TU: Card with 4 voltage transformer measuring inputs (0 ... 800 VAC, under UL: 0 ... 600 VAC)
- X103** – Profibus-DP, RS485, D-SUB
- X104** – IRIG-B00X, incl. System Contact (Supervision Contact)

MRA4-2A1AEB

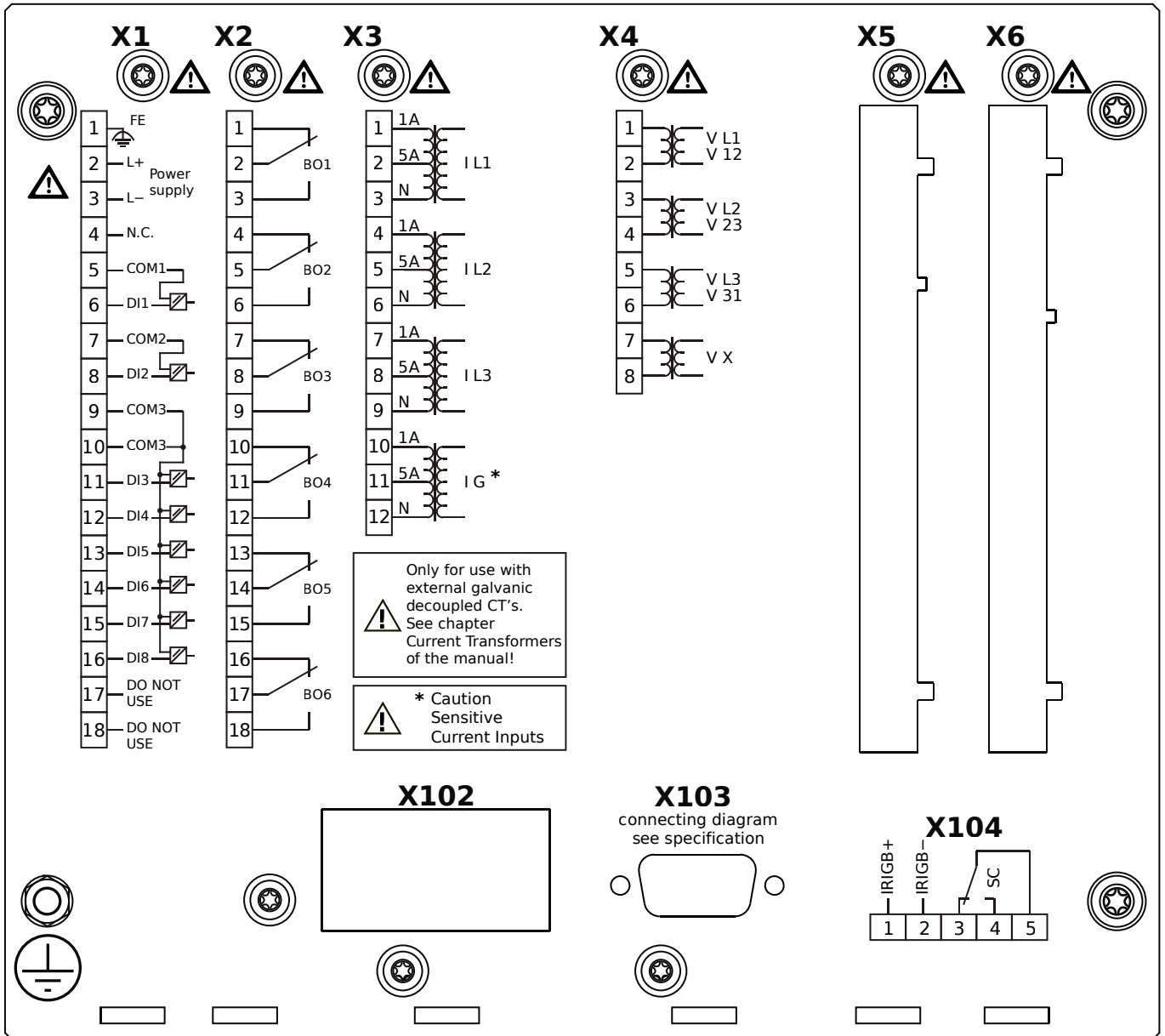

Housing B2, small display, door mounting

+ Conformal Coating (for installations in harsh environment)

- X1** – DI8-X1: Wide-range power supply unit, incl. 2 non-grouped digital inputs and 6 grouped digital inputs
- X2** – OR6: Assembly Group with 6 Output Relays (Changeover / Form C)
- X3** – TIs: Standard phase current measuring card and sensitive ground current measuring
- X4** – TU: Card with 4 voltage transformer measuring inputs (0 ... 800 VAC, under UL: 0 ... 600 VAC)
- X103** – Profibus-DP, RS485, D-SUB
- X104** – IRIG-B00X, incl. System Contact (Supervision Contact)

MRA4-2A1AFA

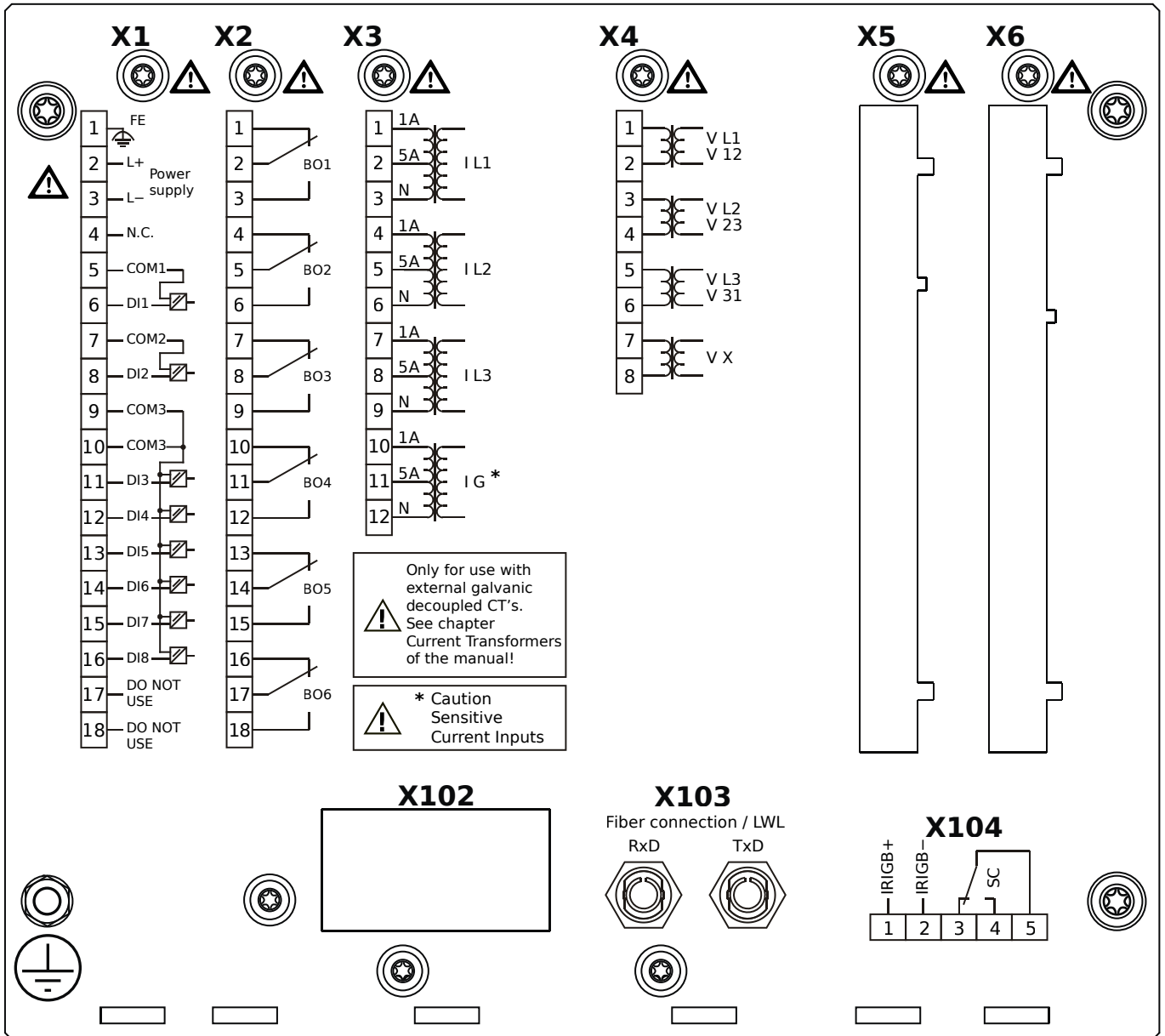

Housing B2, small display, door mounting

- X1** – DI8-X1: Wide-range power supply unit, incl. 2 non-grouped digital inputs and 6 grouped digital inputs
- X2** – OR6: Assembly Group with 6 Output Relays (Changeover / Form C)
- X3** – TIs: Standard phase current measuring card and sensitive ground current measuring
- X4** – TU: Card with 4 voltage transformer measuring inputs (0 ... 800 VAC, under UL: 0 ... 600 VAC)
- X103** – Modbus RTU / IEC 60870-5-103 / DNP3.0 RTU, Fiber optics interface, ST Connector
- X104** – IRIG-B00X, incl. System Contact (Supervision Contact)

MRA4-2A1AFB

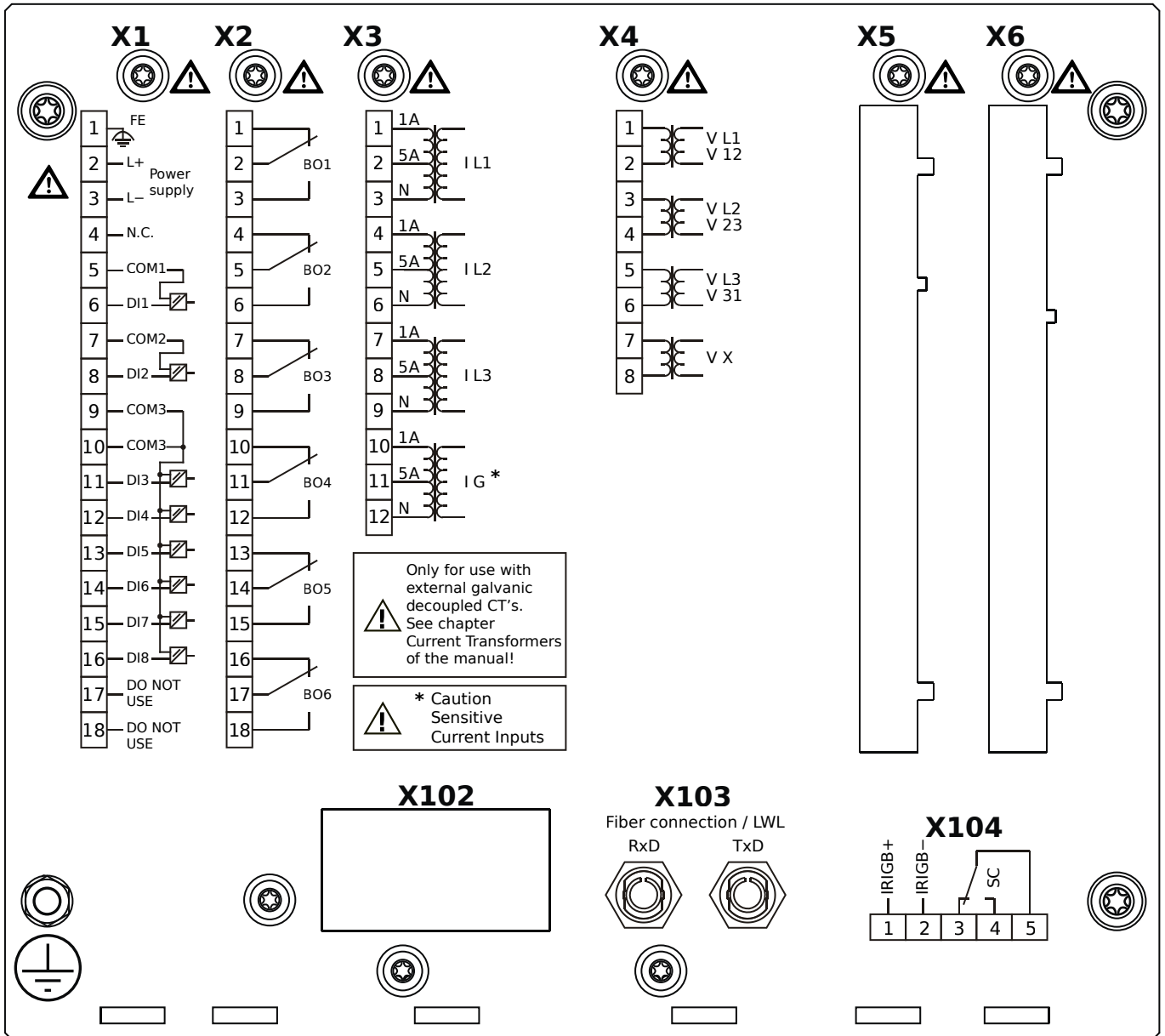

Housing B2, small display, door mounting

+ Conformal Coating (for installations in harsh environment)

- X1** – DI8-X1: Wide-range power supply unit, incl. 2 non-grouped digital inputs and 6 grouped digital inputs
- X2** – OR6: Assembly Group with 6 Output Relays (Changeover / Form C)
- X3** – TIs: Standard phase current measuring card and sensitive ground current measuring
- X4** – TU: Card with 4 voltage transformer measuring inputs (0 ... 800 VAC, under UL: 0 ... 600 VAC)
- X103** – Modbus RTU / IEC 60870-5-103 / DNP3.0 RTU, Fiber optics interface, ST Connector
- X104** – IRIG-B00X, incl. System Contact (Supervision Contact)

MRA4-2A1AGA

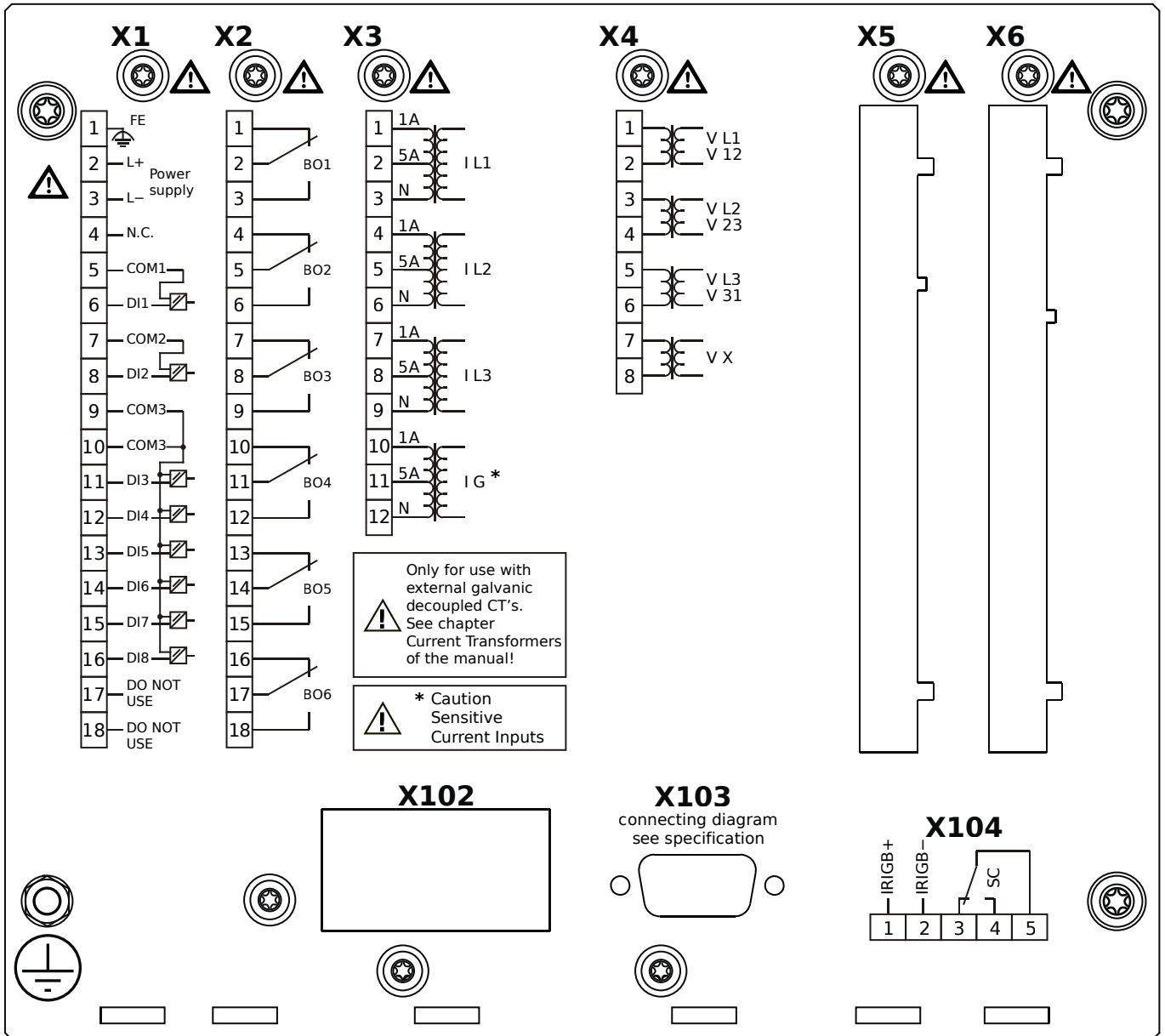

Housing B2, small display, door mounting

- X1** – DI8-X1: Wide-range power supply unit, incl. 2 non-grouped digital inputs and 6 grouped digital inputs
- X2** – OR6: Assembly Group with 6 Output Relays (Changeover / Form C)
- X3** – TIs: Standard phase current measuring card and sensitive ground current measuring
- X4** – TU: Card with 4 voltage transformer measuring inputs (0 ... 800 VAC, under UL: 0 ... 600 VAC)
- X103** – Modbus RTU / IEC 60870-5-103 / DNP3.0 RTU, RS485, D-SUB
- X104** – IRIG-B00X, incl. System Contact (Supervision Contact)

MRA4-2A1AGB

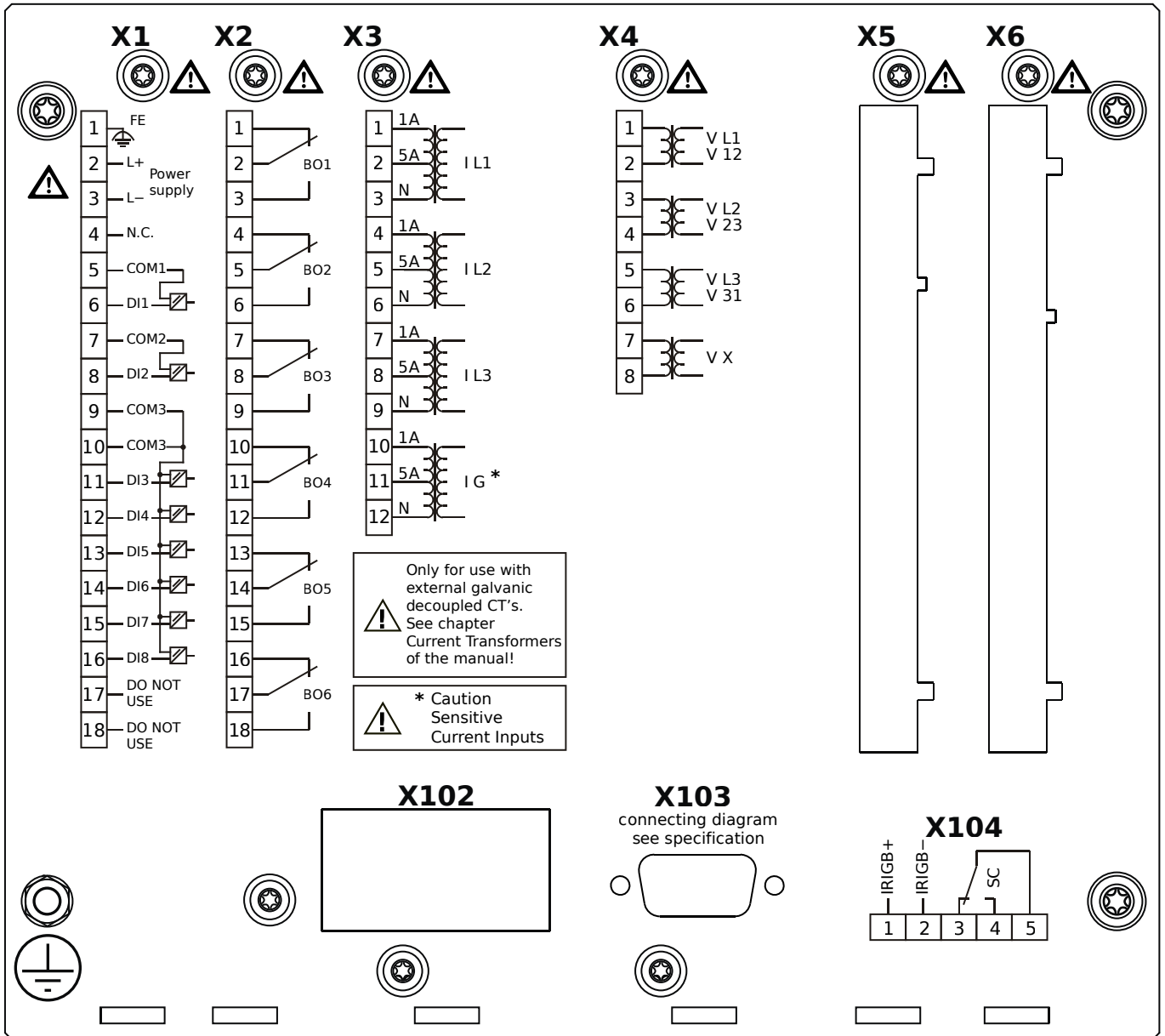

Housing B2, small display, door mounting

+ Conformal Coating (for installations in harsh environment)

- X1** – DI8-X1: Wide-range power supply unit, incl. 2 non-grouped digital inputs and 6 grouped digital inputs
- X2** – OR6: Assembly Group with 6 Output Relays (Changeover / Form C)
- X3** – TIs: Standard phase current measuring card and sensitive ground current measuring
- X4** – TU: Card with 4 voltage transformer measuring inputs (0 ... 800 VAC, under UL: 0 ... 600 VAC)
- X103** – Modbus RTU / IEC 60870-5-103 / DNP3.0 RTU, RS485, D-SUB
- X104** – IRIG-B00X, incl. System Contact (Supervision Contact)

MRA4-2A1AHA

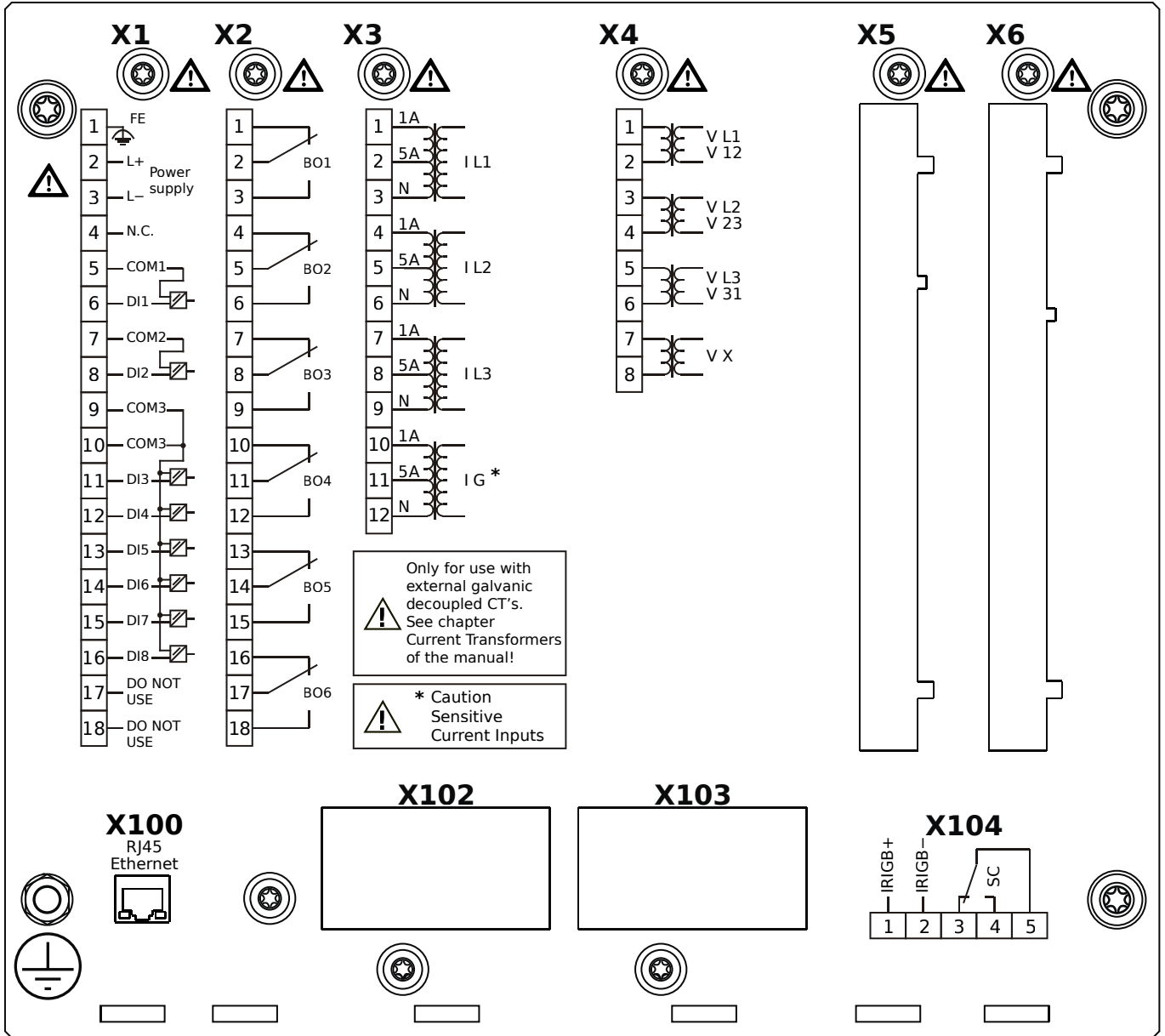

Housing B2, small display, door mounting

- X1** – DI8-X1: Wide-range power supply unit, incl. 2 non-grouped digital inputs and 6 grouped digital inputs
- X2** – OR6: Assembly Group with 6 Output Relays (Changeover / Form C)
- X3** – TIs: Standard phase current measuring card and sensitive ground current measuring
- X4** – TU: Card with 4 voltage transformer measuring inputs (0 ... 800 VAC, under UL: 0 ... 600 VAC)
- X100** – IEC 61850 / Modbus TCP / DNP3.0 TCP/UDP, Ethernet interface, 100 Mbit/s, RJ45 (BASE100-FX)
- X104** – IRIG-B00X, incl. System Contact (Supervision Contact)

MRA4-2A1AHB

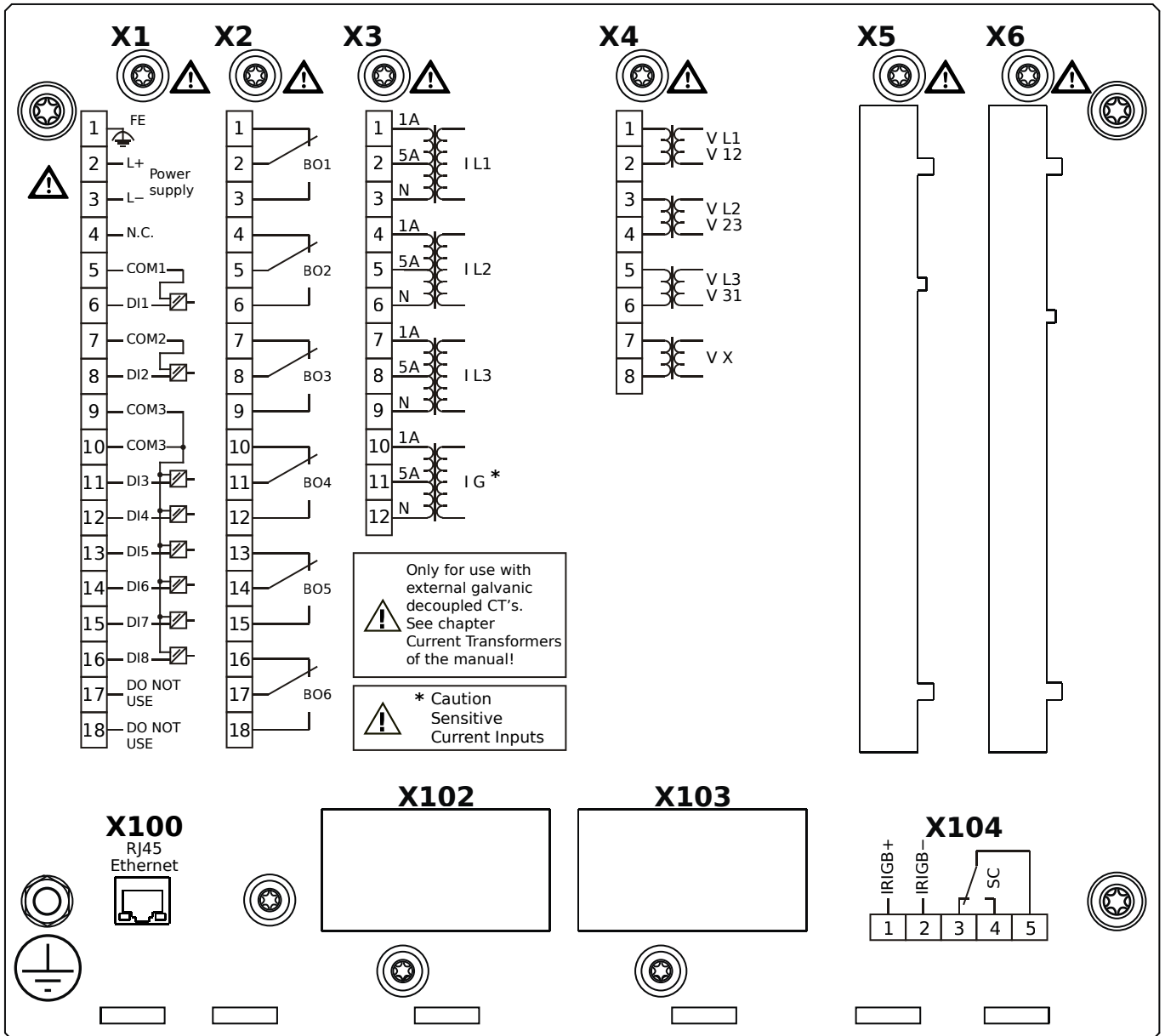

Housing B2, small display, door mounting

+ Conformal Coating (for installations in harsh environment)

- X1** – DI8-X1: Wide-range power supply unit, incl. 2 non-grouped digital inputs and 6 grouped digital inputs
- X2** – OR6: Assembly Group with 6 Output Relays (Changeover / Form C)
- X3** – TIs: Standard phase current measuring card and sensitive ground current measuring
- X4** – TU: Card with 4 voltage transformer measuring inputs (0 ... 800 VAC, under UL: 0 ... 600 VAC)
- X100** – IEC 61850 / Modbus TCP / DNP3.0 TCP/UDP, Ethernet interface, 100 Mbit/s, RJ45 (BASE100-FX)
- X104** – IRIG-B00X, incl. System Contact (Supervision Contact)

MRA4-2A1AIA

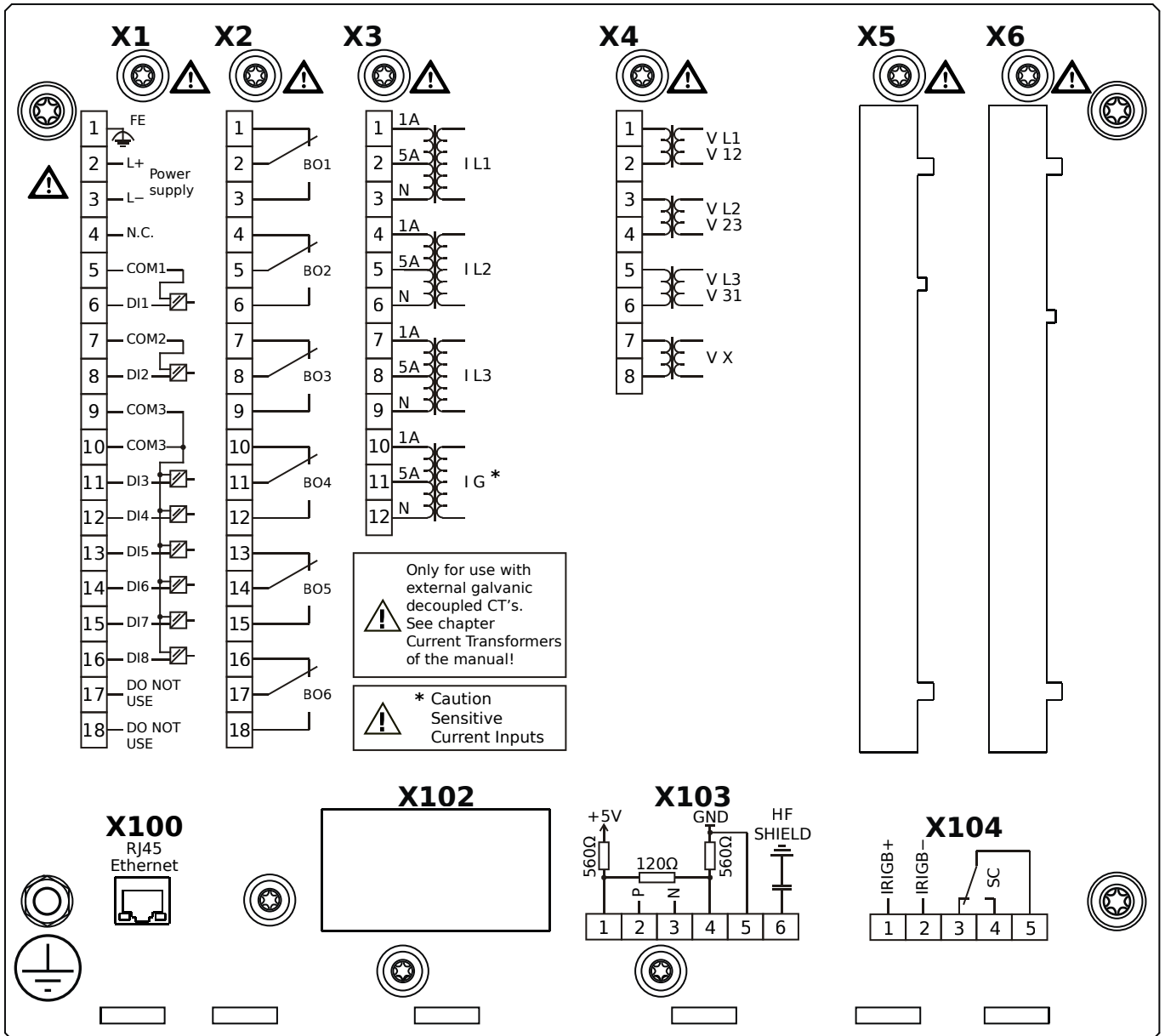

Housing B2, small display, door mounting

- X1** – DI8-X1: Wide-range power supply unit, incl. 2 non-grouped digital inputs and 6 grouped digital inputs
- X2** – OR6: Assembly Group with 6 Output Relays (Changeover / Form C)
- X3** – TIs: Standard phase current measuring card and sensitive ground current measuring
- X4** – TU: Card with 4 voltage transformer measuring inputs (0 ... 800 VAC, under UL: 0 ... 600 VAC)
- X100** – Modbus TCP / DNP3.0 TCP/UDP, Ethernet interface, 100 Mbit/s, RJ45 (BASE100-FX)
- X103** – IEC 60870-5-103 / Modbus RTU / DNP3.0 RTU, RS485, Terminals
- X104** – IRIG-B00X, incl. System Contact (Supervision Contact)

MRA4-2A1AIB

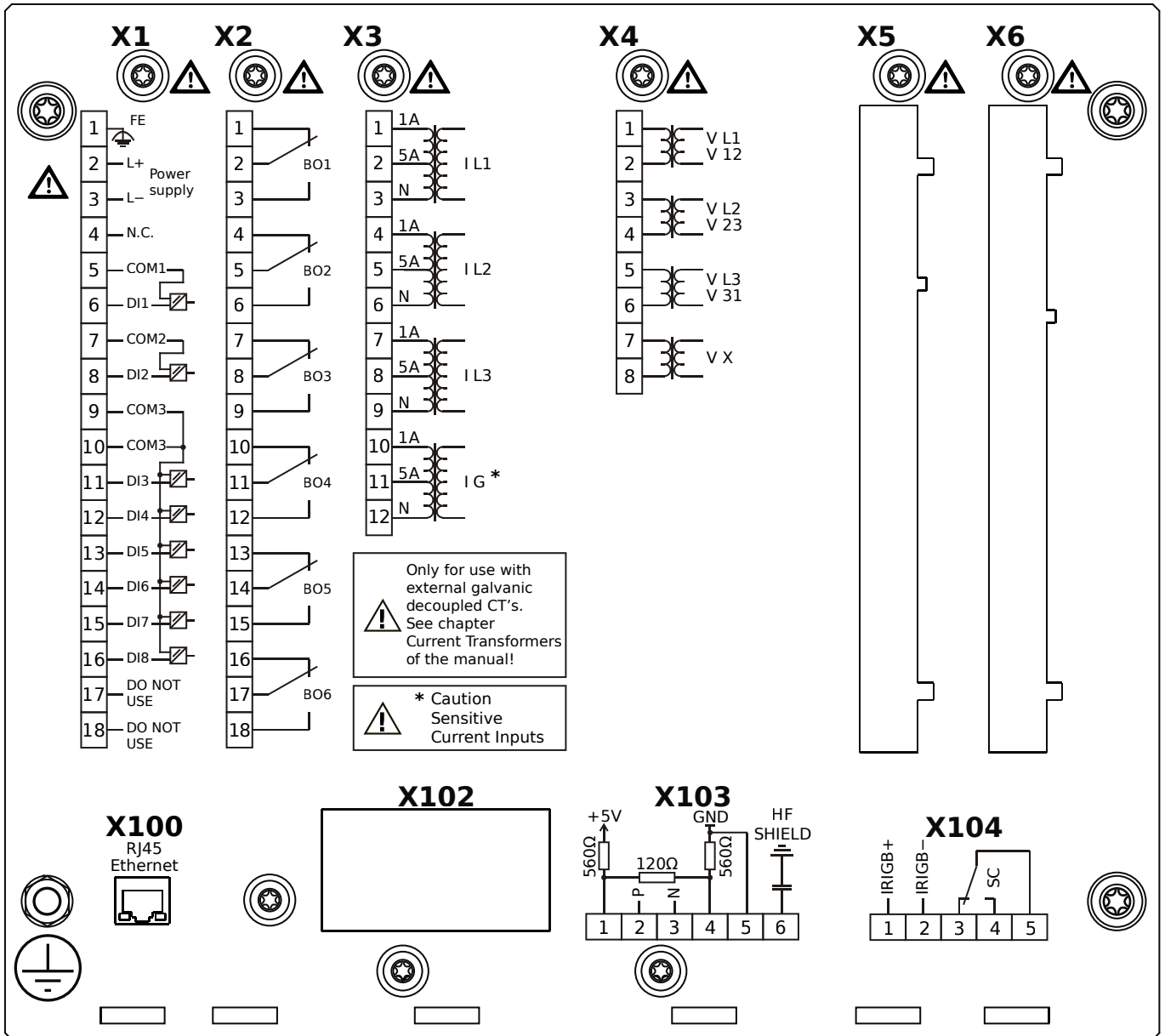

Housing B2, small display, door mounting

+ Conformal Coating (for installations in harsh environment)

- X1** – DI8-X1: Wide-range power supply unit, incl. 2 non-grouped digital inputs and 6 grouped digital inputs
- X2** – OR6: Assembly Group with 6 Output Relays (Changeover / Form C)
- X3** – TIs: Standard phase current measuring card and sensitive ground current measuring
- X4** – TU: Card with 4 voltage transformer measuring inputs (0 ... 800 VAC, under UL: 0 ... 600 VAC)
- X100** – Modbus TCP / DNP3.0 TCP/UDP, Ethernet interface, 100 Mbit/s, RJ45 (BASE100-FX)
- X103** – IEC 60870-5-103 / Modbus RTU / DNP3.0 RTU, RS485, Terminals
- X104** – IRIG-B00X, incl. System Contact (Supervision Contact)

MRA4-2A1AKA

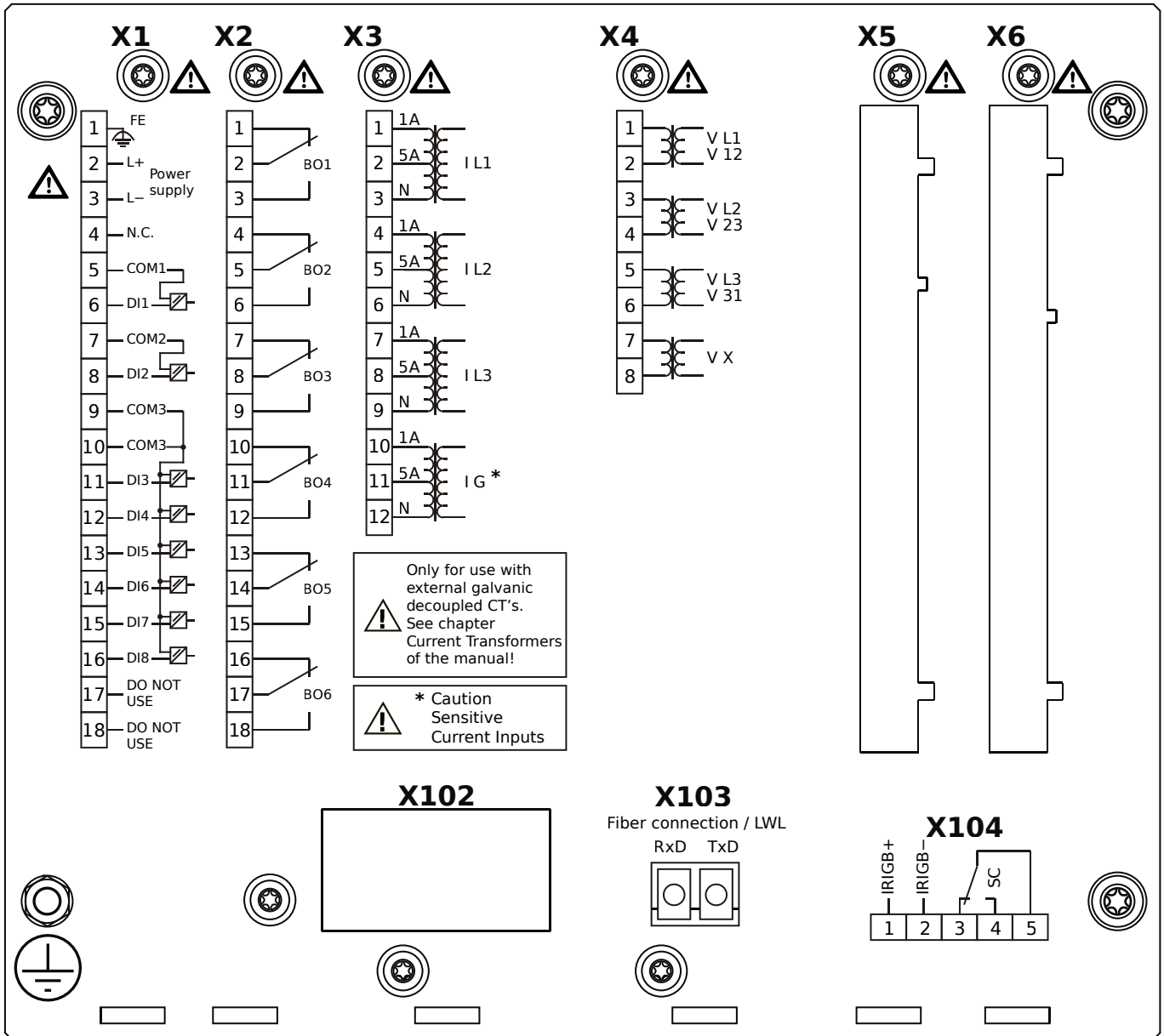

Housing B2, small display, door mounting

- X1** – DI8-X1: Wide-range power supply unit, incl. 2 non-grouped digital inputs and 6 grouped digital inputs
- X2** – OR6: Assembly Group with 6 Output Relays (Changeover / Form C)
- X3** – TIs: Standard phase current measuring card and sensitive ground current measuring
- X4** – TU: Card with 4 voltage transformer measuring inputs (0 ... 800 VAC, under UL: 0 ... 600 VAC)
- X103** – IEC 61850 / Modbus TCP / DNP3.0 TCP/UDP, Fiber optics interface, LC Connector
- X104** – IRIG-B00X, incl. System Contact (Supervision Contact)

MRA4-2A1AKB

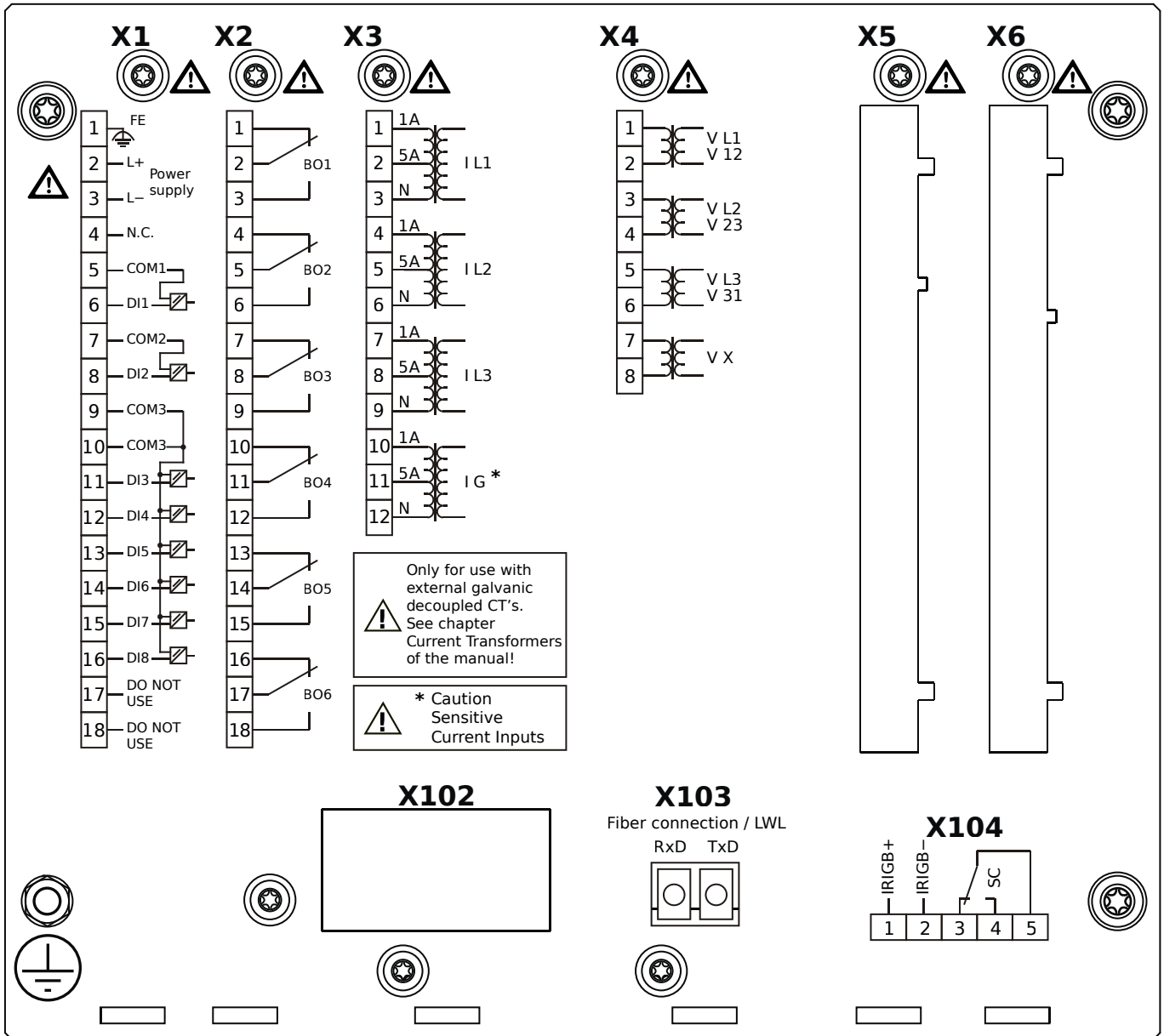

Housing B2, small display, door mounting

+ Conformal Coating (for installations in harsh environment)

- X1** – DI8-X1: Wide-range power supply unit, incl. 2 non-grouped digital inputs and 6 grouped digital inputs
- X2** – OR6: Assembly Group with 6 Output Relays (Changeover / Form C)
- X3** – TIs: Standard phase current measuring card and sensitive ground current measuring
- X4** – TU: Card with 4 voltage transformer measuring inputs (0 ... 800 VAC, under UL: 0 ... 600 VAC)
- X103** – IEC 61850 / Modbus TCP / DNP3.0 TCP/UDP, Fiber optics interface, LC Connector
- X104** – IRIG-B00X, incl. System Contact (Supervision Contact)

MRA4-2A1ALA

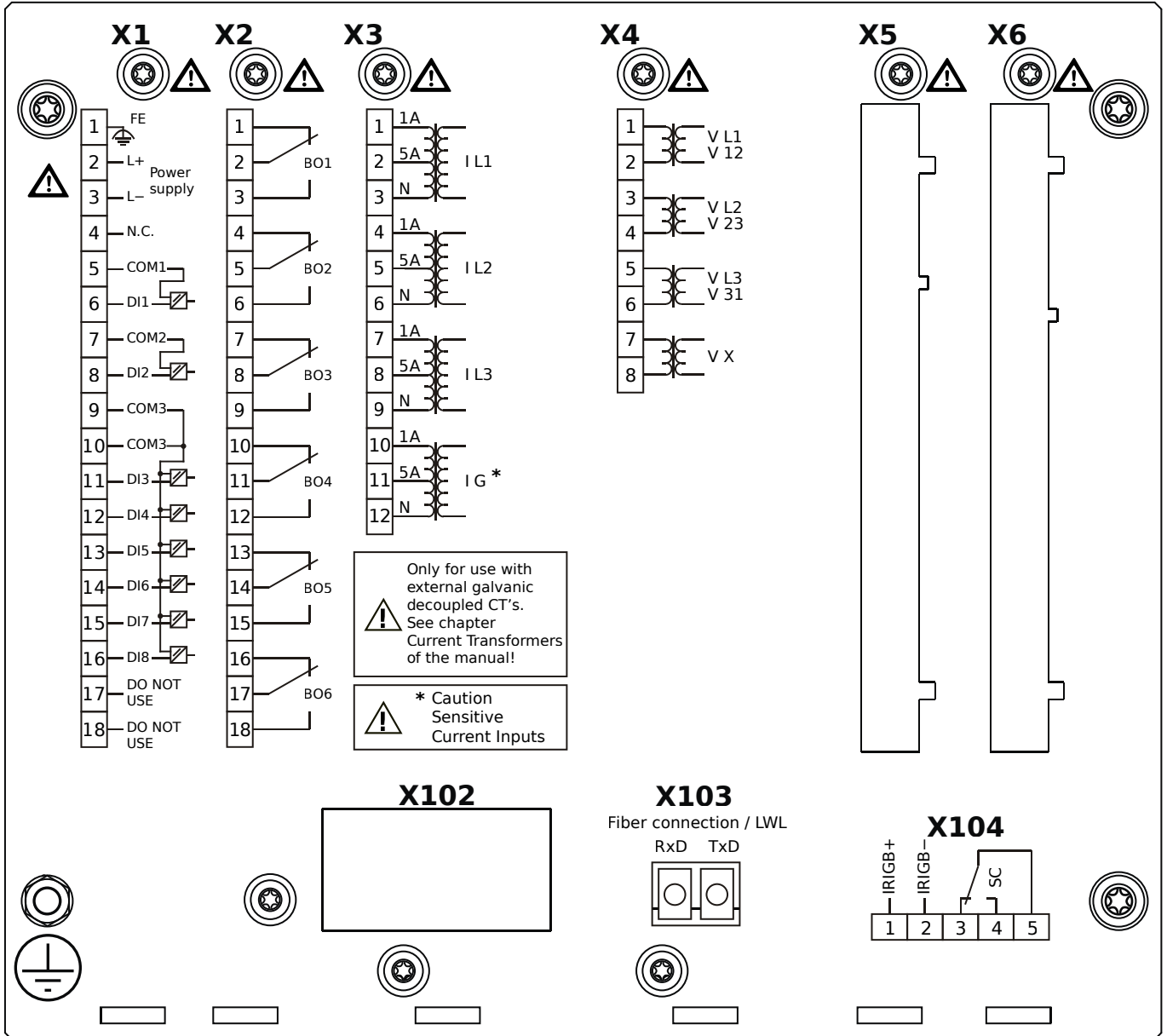

Housing B2, small display, door mounting

- X1** – DI8-X1: Wide-range power supply unit, incl. 2 non-grouped digital inputs and 6 grouped digital inputs
- X2** – OR6: Assembly Group with 6 Output Relays (Changeover / Form C)
- X3** – TIs: Standard phase current measuring card and sensitive ground current measuring
- X4** – TU: Card with 4 voltage transformer measuring inputs (0 ... 800 VAC, under UL: 0 ... 600 VAC)
- X103** – Modbus TCP / DNP3.0 TCP/UDP, Fiber optics interface, LC Connector
- X104** – IRIG-B00X, incl. System Contact (Supervision Contact)

MRA4-2A1ALB

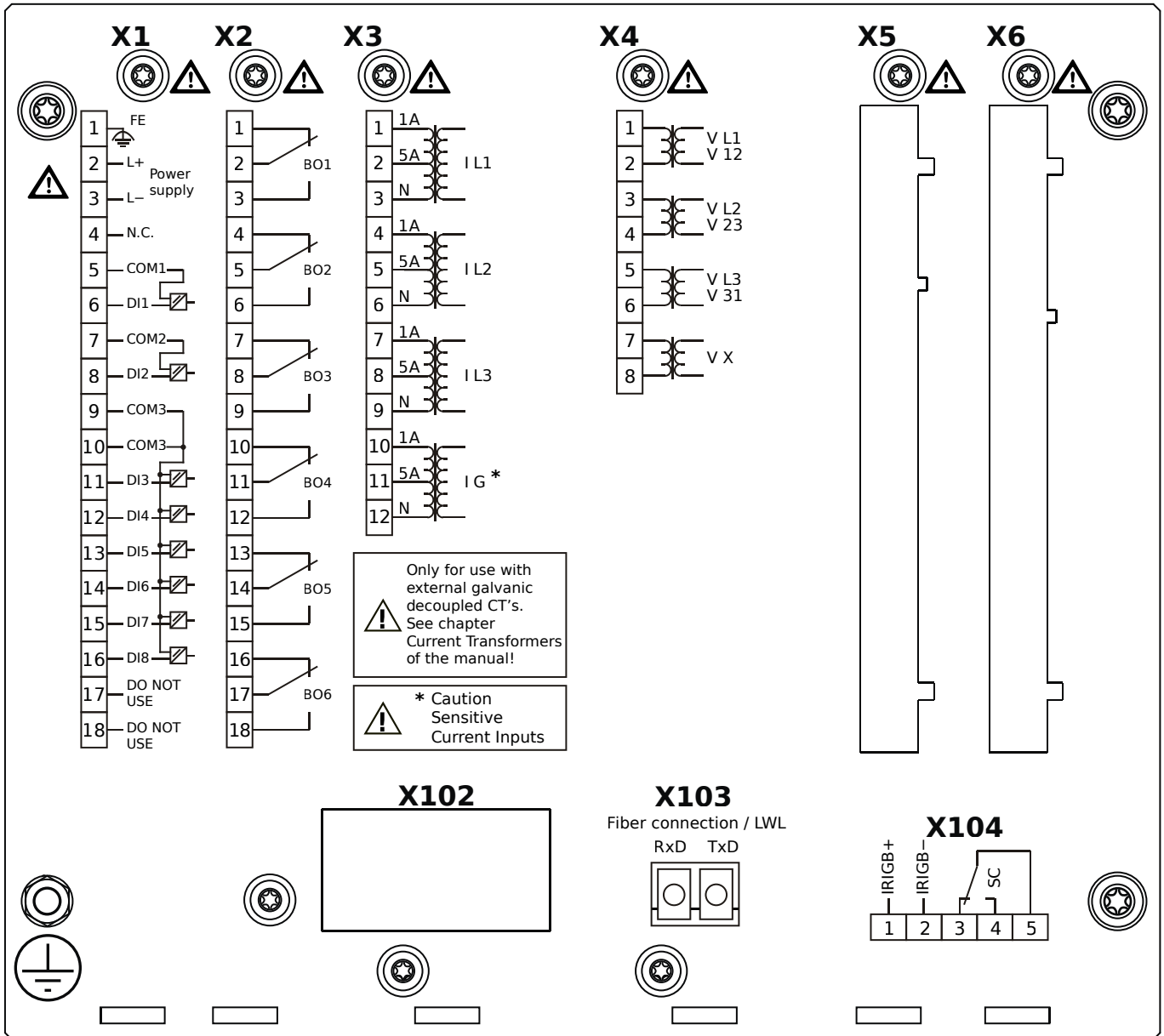

Housing B2, small display, door mounting

+ Conformal Coating (for installations in harsh environment)

- X1** – DI8-X1: Wide-range power supply unit, incl. 2 non-grouped digital inputs and 6 grouped digital inputs
- X2** – OR6: Assembly Group with 6 Output Relays (Changeover / Form C)
- X3** – TIs: Standard phase current measuring card and sensitive ground current measuring
- X4** – TU: Card with 4 voltage transformer measuring inputs (0 ... 800 VAC, under UL: 0 ... 600 VAC)
- X103** – Modbus TCP / DNP3.0 TCP/UDP, Fiber optics interface, LC Connector
- X104** – IRIG-B00X, incl. System Contact (Supervision Contact)

MRA4-2A1ATA

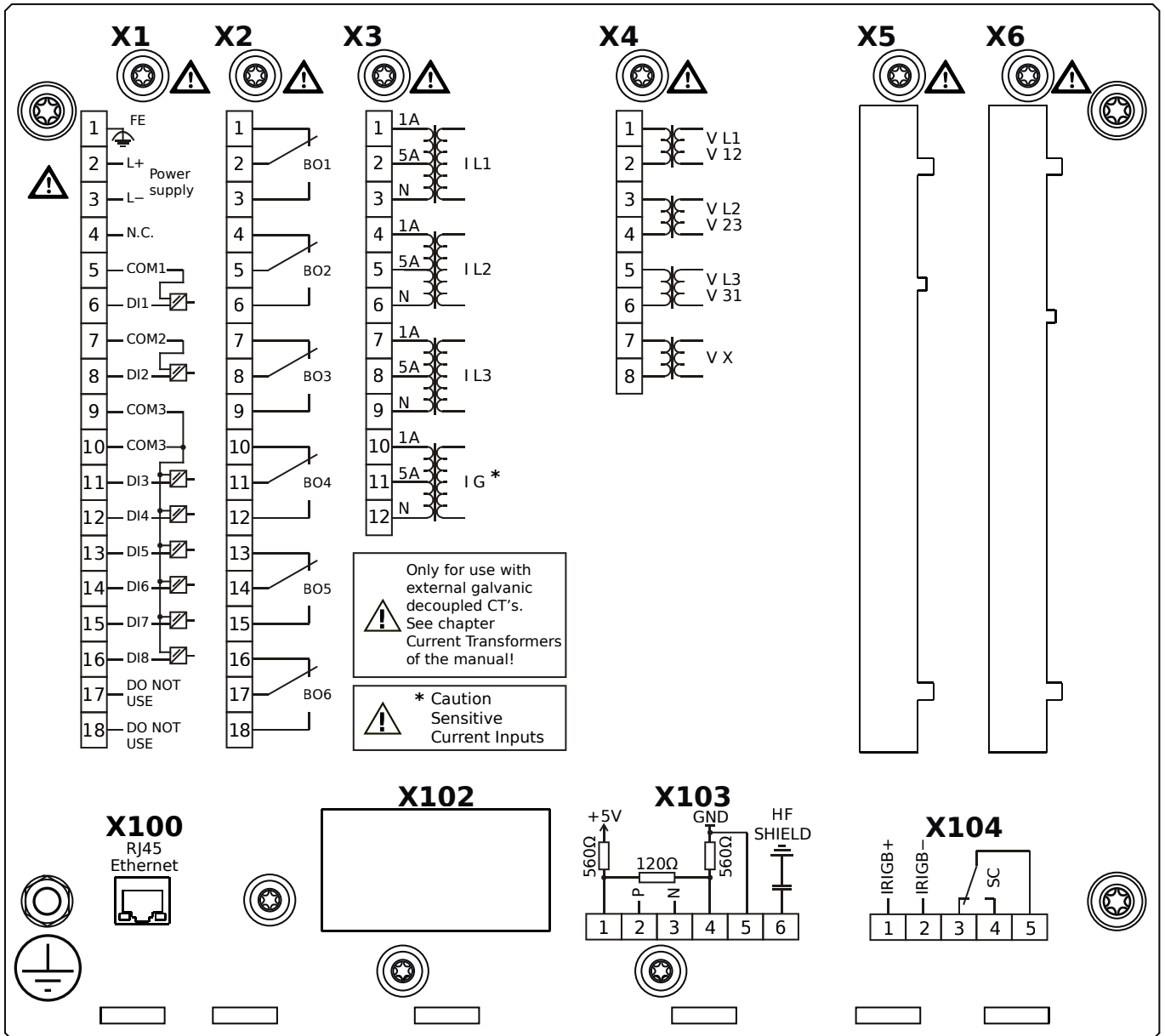

Housing B2, small display, door mounting

- X1** – DI8-X1: Wide-range power supply unit, incl. 2 non-grouped digital inputs and 6 grouped digital inputs
- X2** – OR6: Assembly Group with 6 Output Relays (Changeover / Form C)
- X3** – TIs: Standard phase current measuring card and sensitive ground current measuring
- X4** – TU: Card with 4 voltage transformer measuring inputs (0 ... 800 VAC, under UL: 0 ... 600 VAC)
- X100** – IEC 61850 / Modbus TCP / DNP3.0 TCP/UDP, Ethernet interface, 100 Mbit/s, RJ45 (BASE100-FX)
- X103** – IEC 60870-5-103 / Modbus RTU / DNP3.0 RTU, RS485, Terminals
- X104** – IRIG-B00X, incl. System Contact (Supervision Contact)

MRA4-2A1ATB

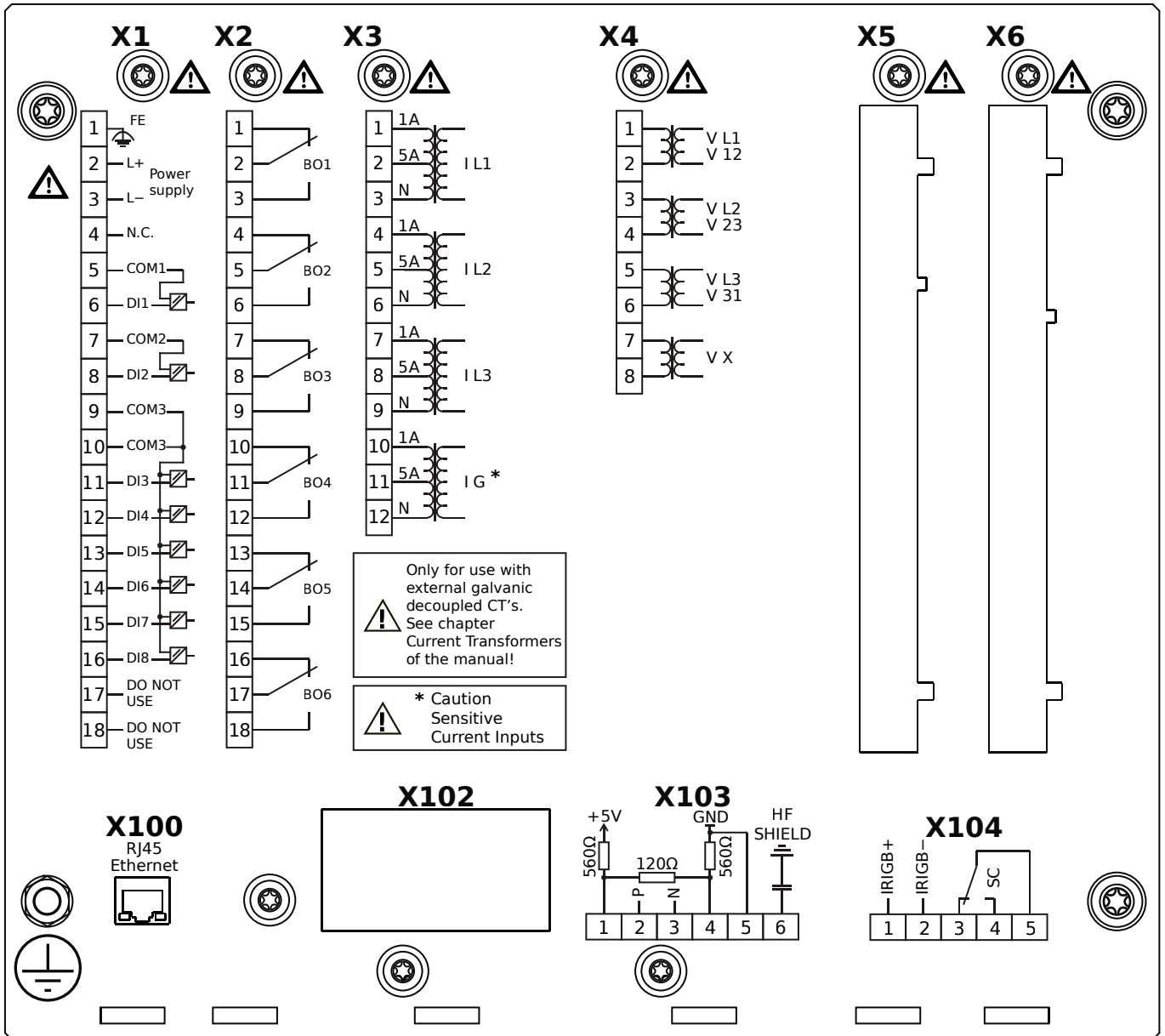

Housing B2, small display, door mounting

+ Conformal Coating (for installations in harsh environment)

- X1** – DI8-X1: Wide-range power supply unit, incl. 2 non-grouped digital inputs and 6 grouped digital inputs
- X2** – OR6: Assembly Group with 6 Output Relays (Changeover / Form C)
- X3** – TIs: Standard phase current measuring card and sensitive ground current measuring
- X4** – TU: Card with 4 voltage transformer measuring inputs (0 ... 800 VAC, under UL: 0 ... 600 VAC)
- X100** – IEC 61850 / Modbus TCP / DNP3.0 TCP/UDP, Ethernet interface, 100 Mbit/s, RJ45 (BASE100-FX)
- X103** – IEC 60870-5-103 / Modbus RTU / DNP3.0 RTU, RS485, Terminals
- X104** – IRIG-B00X, incl. System Contact (Supervision Contact)

MRA4-2A1BAA

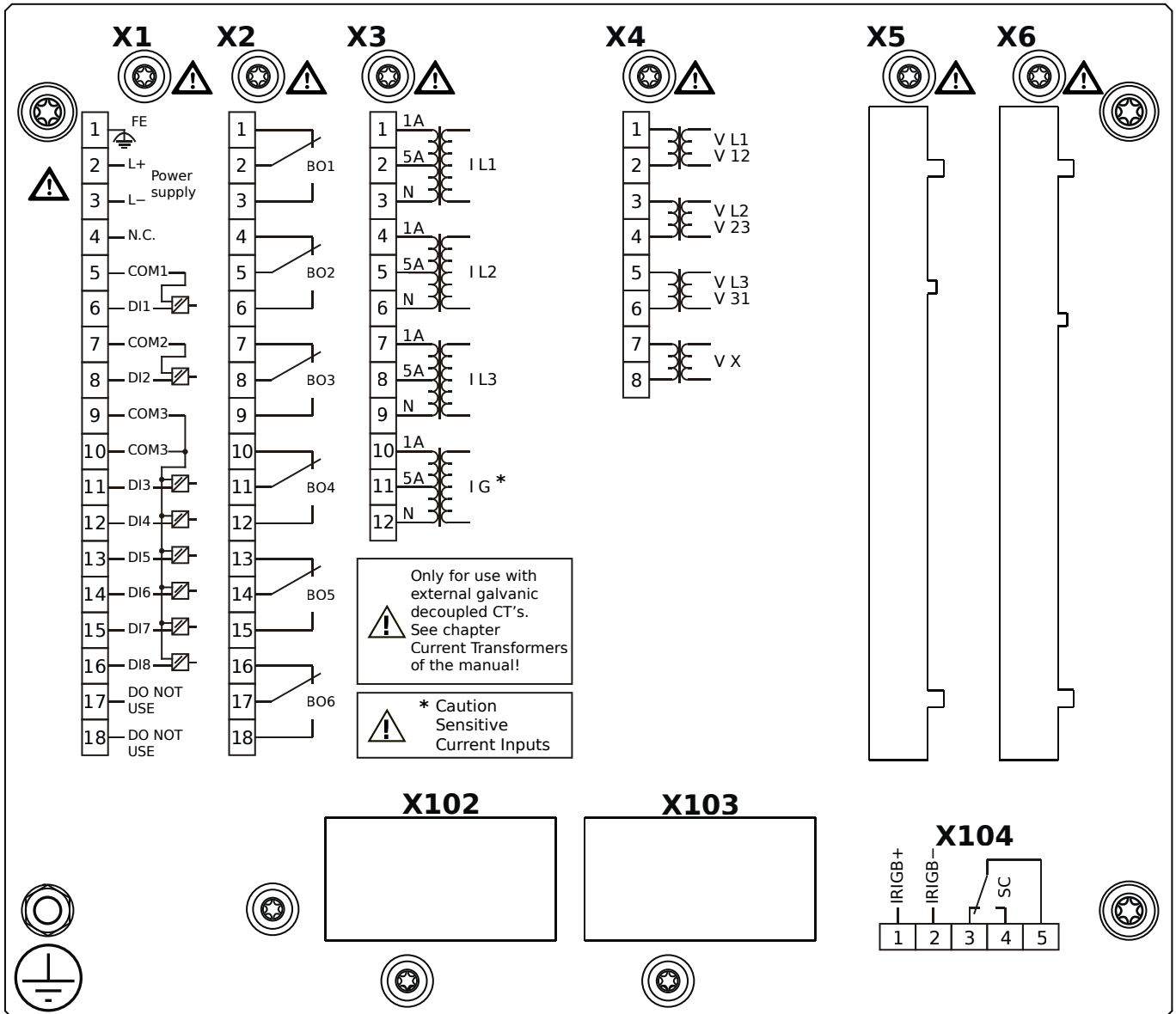

Housing B2, small display, 19" rack mounting

- X1** – DI8-X1: Wide-range power supply unit, incl. 2 non-grouped digital inputs and 6 grouped digital inputs
- X2** – OR6: Assembly Group with 6 Output Relays (Changeover / Form C)
- X3** – TIs: Standard phase current measuring card and sensitive ground current measuring
- X4** – TU: Card with 4 voltage transformer measuring inputs (0 ... 800 VAC, under UL: 0 ... 600 VAC)
- X104** – IRIG-B00X, incl. System Contact (Supervision Contact)

MRA4-2A1BAB

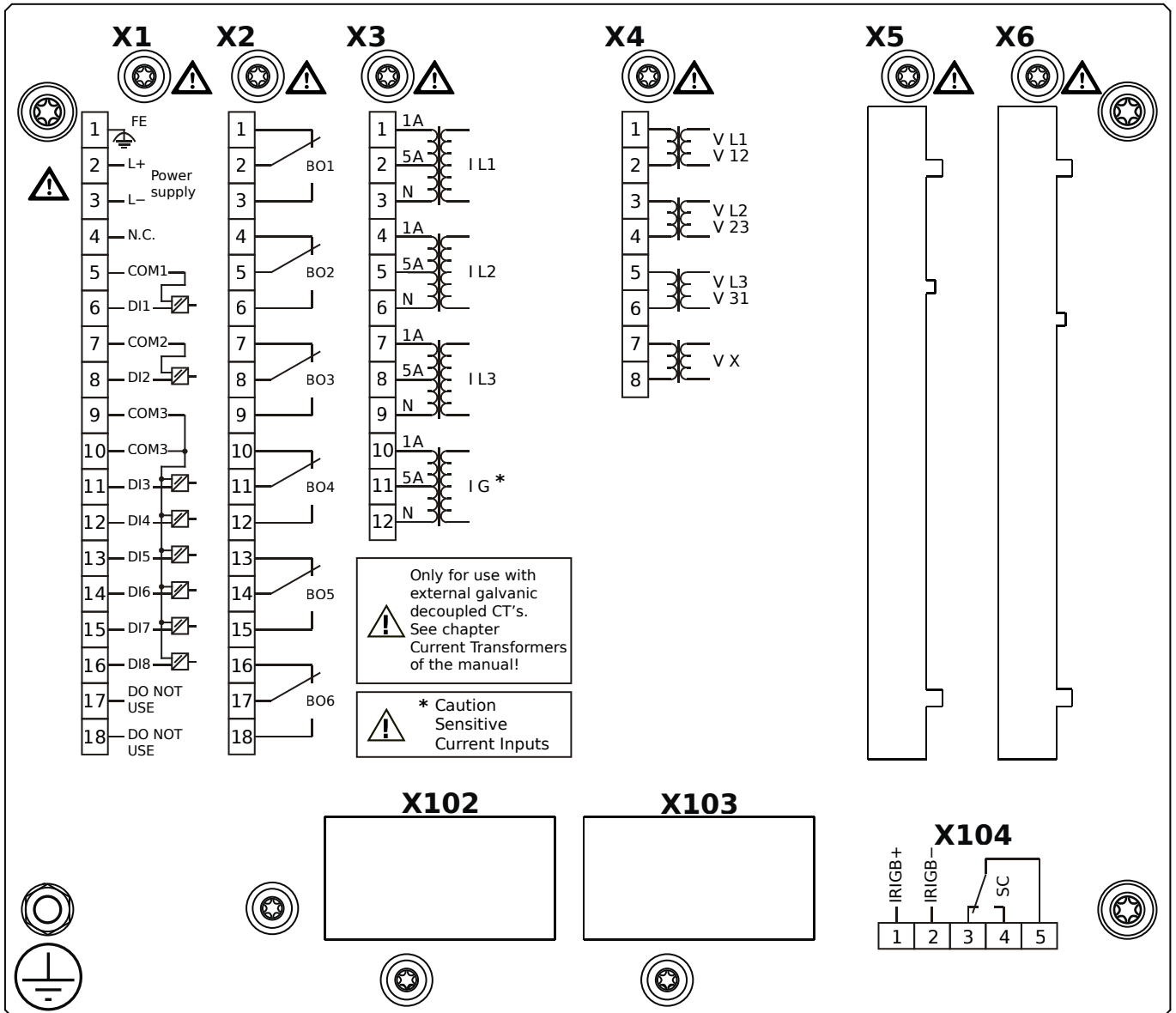

Housing B2, small display, 19" rack mounting

+ Conformal Coating (for installations in harsh environment)

- X1** – DI8-X1: Wide-range power supply unit, incl. 2 non-grouped digital inputs and 6 grouped digital inputs
- X2** – OR6: Assembly Group with 6 Output Relays (Changeover / Form C)
- X3** – TIs: Standard phase current measuring card and sensitive ground current measuring
- X4** – TU: Card with 4 voltage transformer measuring inputs (0 ... 800 VAC, under UL: 0 ... 600 VAC)
- X104** – IRIG-B00X, incl. System Contact (Supervision Contact)

MRA4-2A1BBA

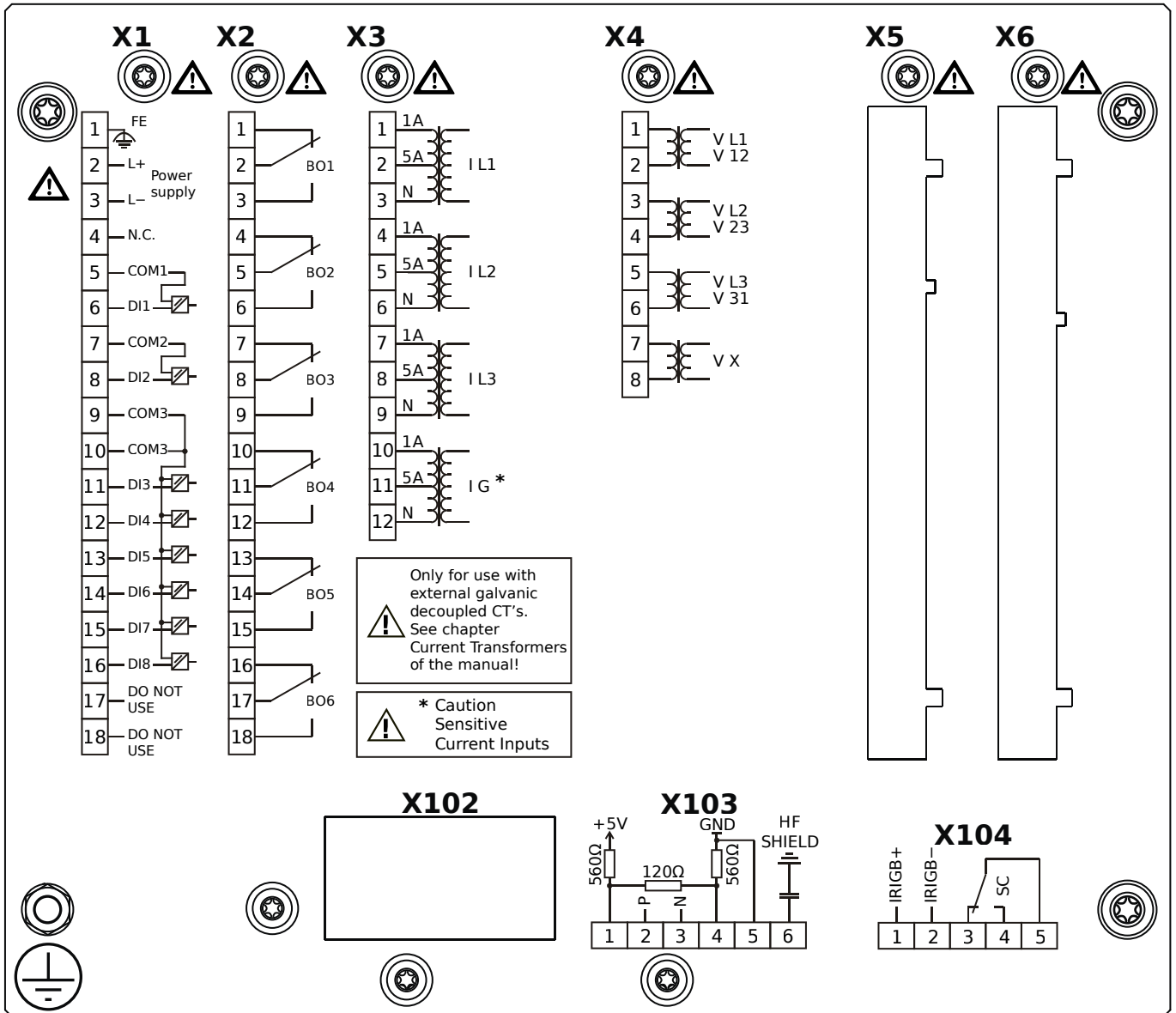

Housing B2, small display, 19" rack mounting

- X1** – DI8-X1: Wide-range power supply unit, incl. 2 non-grouped digital inputs and 6 grouped digital inputs
- X2** – OR6: Assembly Group with 6 Output Relays (Changeover / Form C)
- X3** – TIs: Standard phase current measuring card and sensitive ground current measuring
- X4** – TU: Card with 4 voltage transformer measuring inputs (0 ... 800 VAC, under UL: 0 ... 600 VAC)
- X103** – Modbus RTU / IEC 60870-5-103 / DNP3.0 RTU, RS485, Terminals
- X104** – IRIG-B00X, incl. System Contact (Supervision Contact)

MRA4-2A1BBB

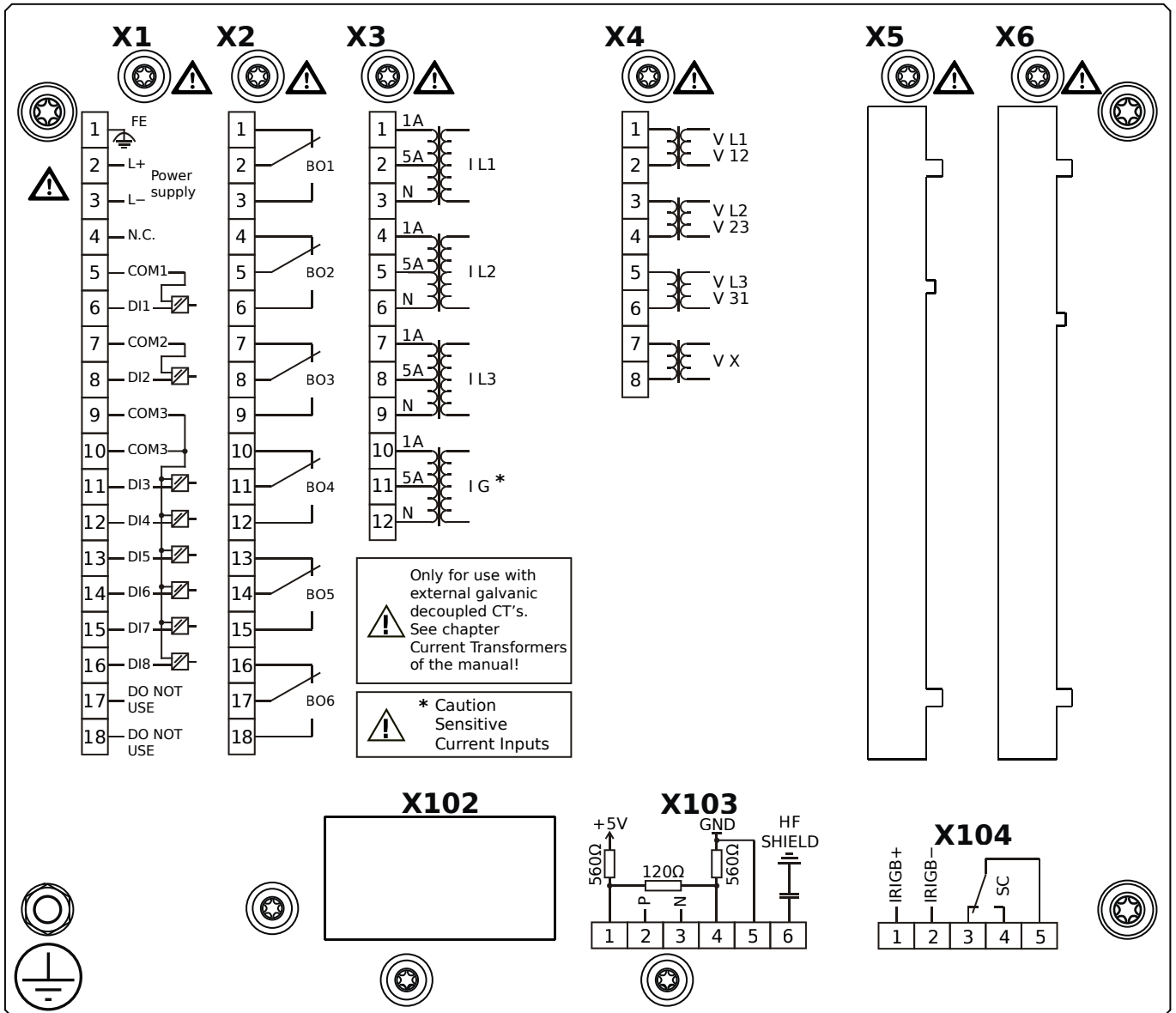

Housing B2, small display, 19" rack mounting

+ Conformal Coating (for installations in harsh environment)

- X1** – DI8-X1: Wide-range power supply unit, incl. 2 non-grouped digital inputs and 6 grouped digital inputs
- X2** – OR6: Assembly Group with 6 Output Relays (Changeover / Form C)
- X3** – TIs: Standard phase current measuring card and sensitive ground current measuring
- X4** – TU: Card with 4 voltage transformer measuring inputs (0 ... 800 VAC, under UL: 0 ... 600 VAC)
- X103** – Modbus RTU / IEC 60870-5-103 / DNP3.0 RTU, RS485, Terminals
- X104** – IRIG-B00X, incl. System Contact (Supervision Contact)

MRA4-2A1BCA

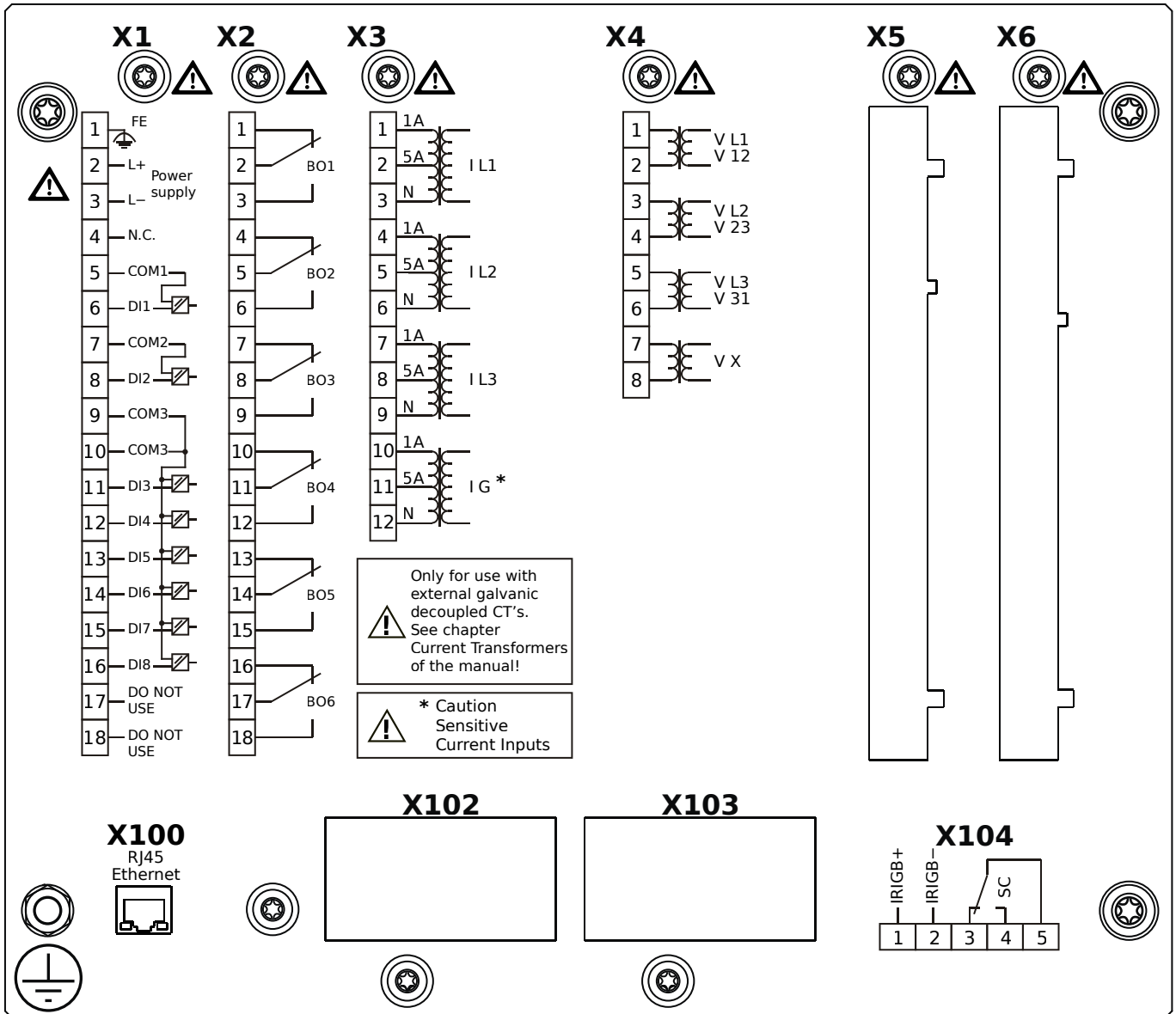

Housing B2, small display, 19" rack mounting

- X1** – DI8-X1: Wide-range power supply unit, incl. 2 non-grouped digital inputs and 6 grouped digital inputs
- X2** – OR6: Assembly Group with 6 Output Relays (Changeover / Form C)
- X3** – TIs: Standard phase current measuring card and sensitive ground current measuring
- X4** – TU: Card with 4 voltage transformer measuring inputs (0 ... 800 VAC, under UL: 0 ... 600 VAC)
- X100** – Modbus TCP / DNP3.0 TCP/UDP, Ethernet interface, 100 Mbit/s, RJ45 (BASE100-FX)
- X104** – IRIG-B00X, incl. System Contact (Supervision Contact)

MRA4-2A1BCB

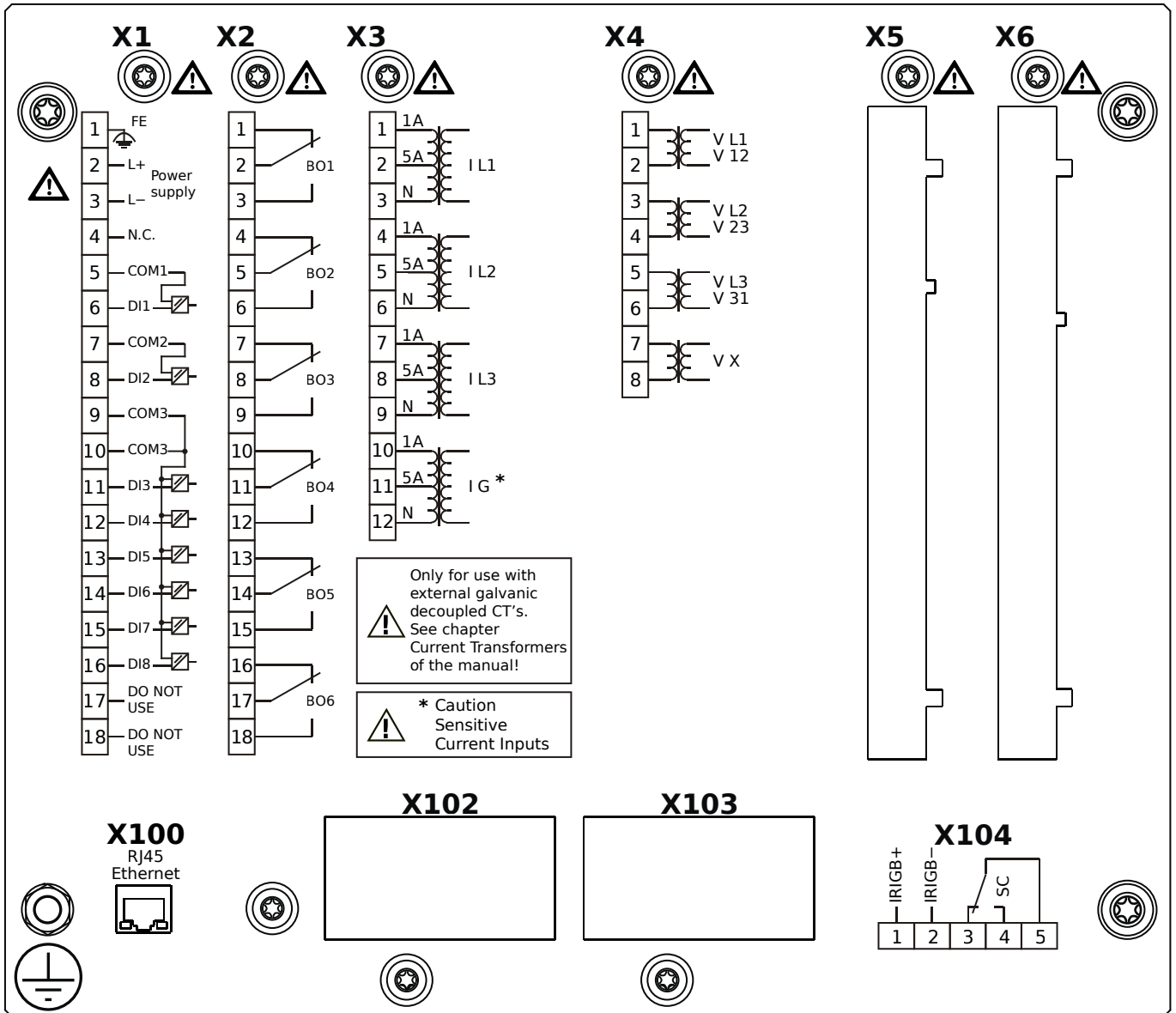

Housing B2, small display, 19" rack mounting

+ Conformal Coating (for installations in harsh environment)

- X1** – DI8-X1: Wide-range power supply unit, incl. 2 non-grouped digital inputs and 6 grouped digital inputs
- X2** – OR6: Assembly Group with 6 Output Relays (Changeover / Form C)
- X3** – TIs: Standard phase current measuring card and sensitive ground current measuring
- X4** – TU: Card with 4 voltage transformer measuring inputs (0 ... 800 VAC, under UL: 0 ... 600 VAC)
- X100** – Modbus TCP / DNP3.0 TCP/UDP, Ethernet interface, 100 Mbit/s, RJ45 (BASE100-FX)
- X104** – IRIG-B00X, incl. System Contact (Supervision Contact)

MRA4-2A1BDA

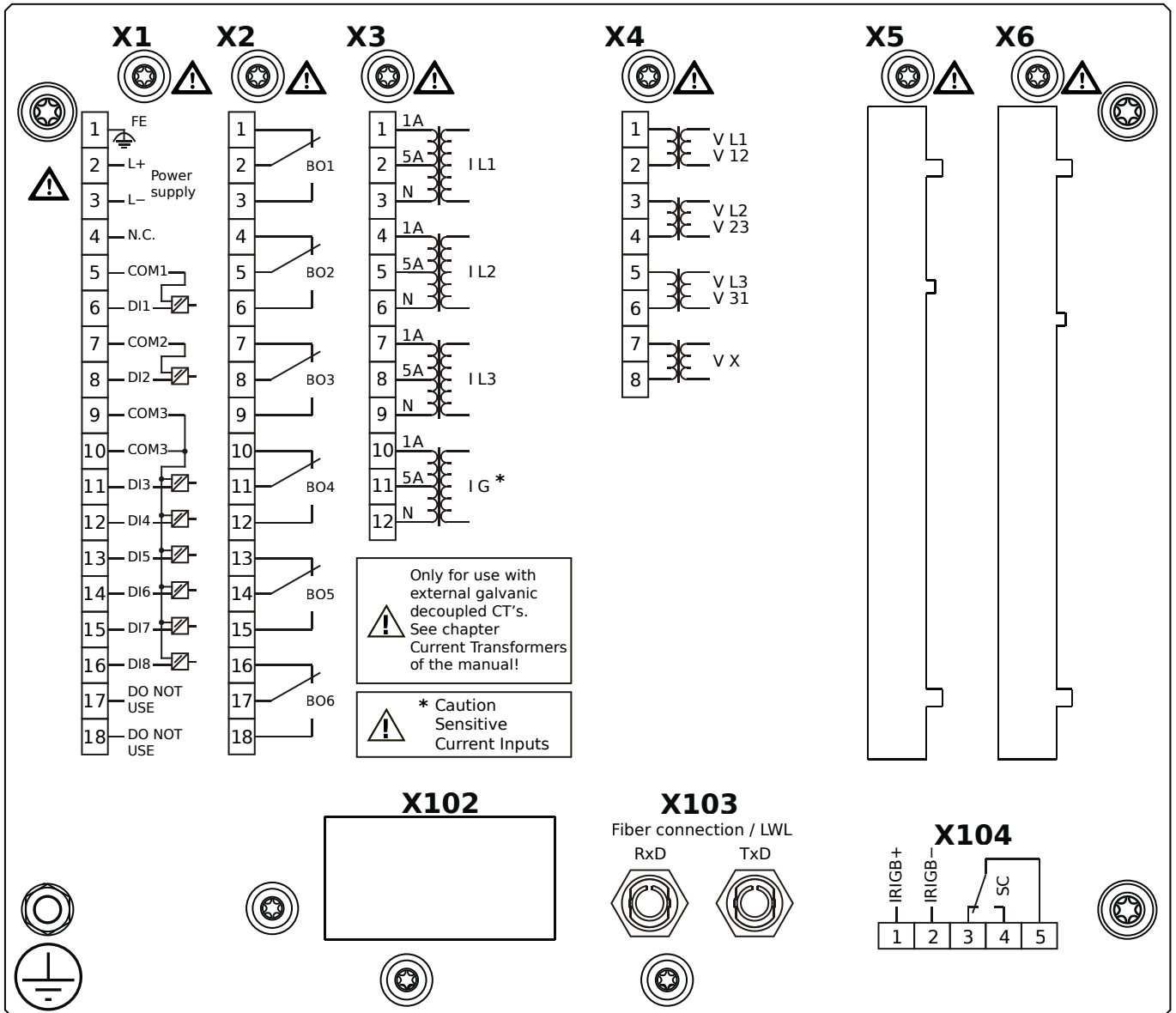

Housing B2, small display, 19" rack mounting

- X1** – DI8-X1: Wide-range power supply unit, incl. 2 non-grouped digital inputs and 6 grouped digital inputs
- X2** – OR6: Assembly Group with 6 Output Relays (Changeover / Form C)
- X3** – TIs: Standard phase current measuring card and sensitive ground current measuring
- X4** – TU: Card with 4 voltage transformer measuring inputs (0 ... 800 VAC, under UL: 0 ... 600 VAC)
- X103** – Profibus-DP, Fiber optics interface, ST Connector
- X104** – IRIG-B00X, incl. System Contact (Supervision Contact)

MRA4-2A1BDB

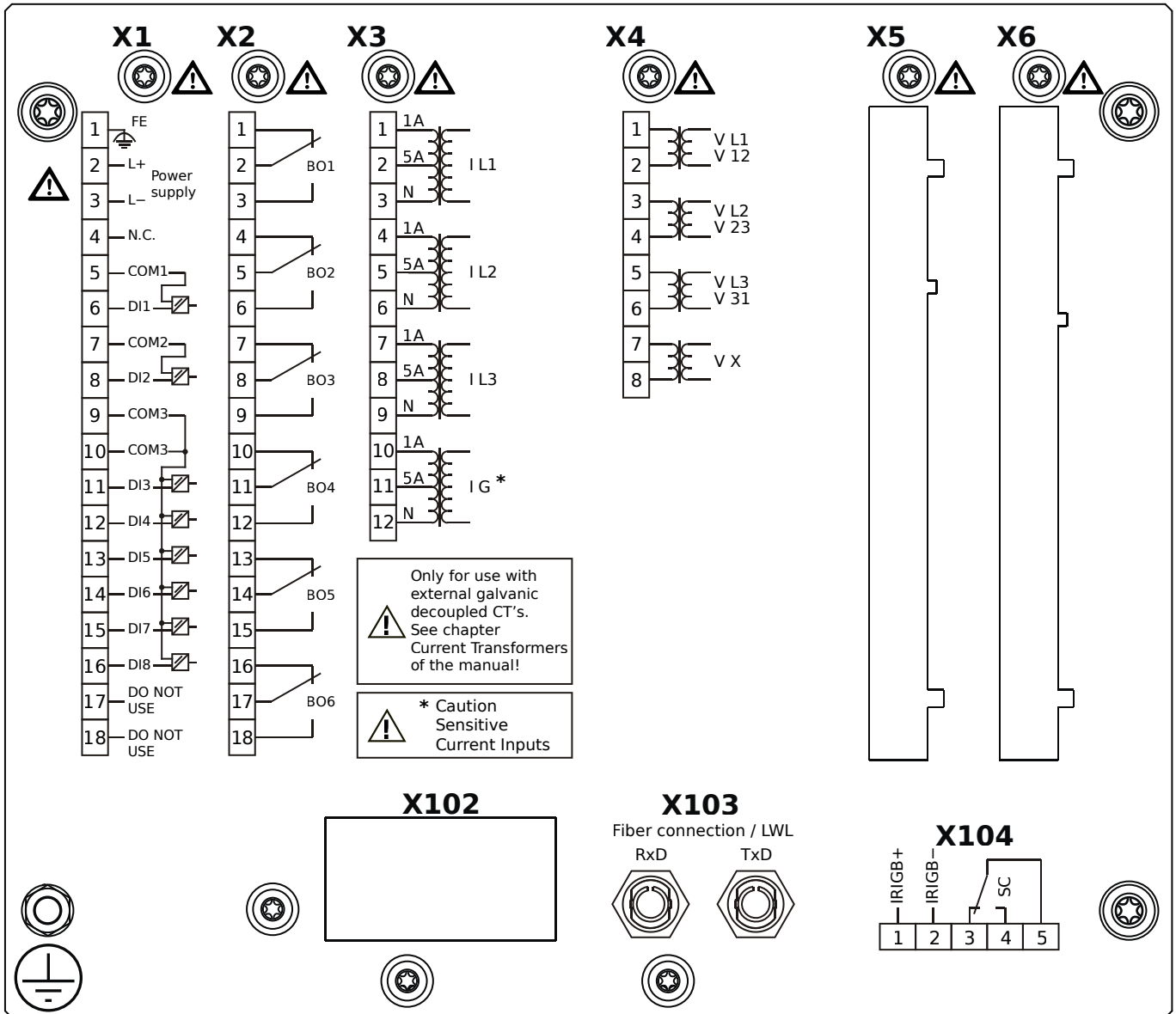

Housing B2, small display, 19" rack mounting

+ Conformal Coating (for installations in harsh environment)

- X1** – DI8-X1: Wide-range power supply unit, incl. 2 non-grouped digital inputs and 6 grouped digital inputs
- X2** – OR6: Assembly Group with 6 Output Relays (Changeover / Form C)
- X3** – TIs: Standard phase current measuring card and sensitive ground current measuring
- X4** – TU: Card with 4 voltage transformer measuring inputs (0 ... 800 VAC, under UL: 0 ... 600 VAC)
- X103** – Profibus-DP, Fiber optics interface, ST Connector
- X104** – IRIG-B00X, incl. System Contact (Supervision Contact)

MRA4-2A1BEA

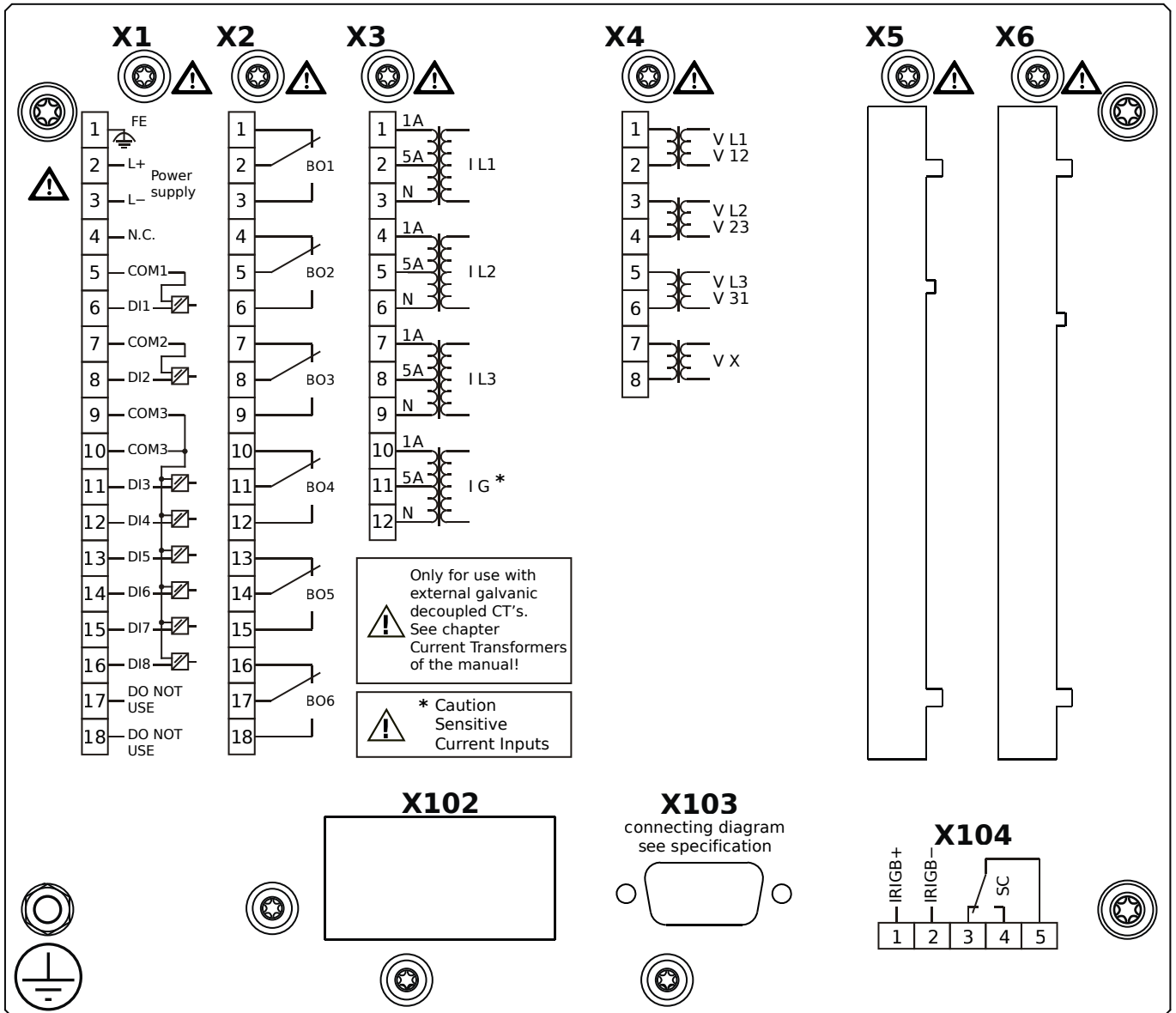

Housing B2, small display, 19" rack mounting

- X1** – DI8-X1: Wide-range power supply unit, incl. 2 non-grouped digital inputs and 6 grouped digital inputs
- X2** – OR6: Assembly Group with 6 Output Relays (Changeover / Form C)
- X3** – TIs: Standard phase current measuring card and sensitive ground current measuring
- X4** – TU: Card with 4 voltage transformer measuring inputs (0 ... 800 VAC, under UL: 0 ... 600 VAC)
- X103** – Profibus-DP, RS485, D-SUB
- X104** – IRIG-B00X, incl. System Contact (Supervision Contact)

MRA4-2A1BEB

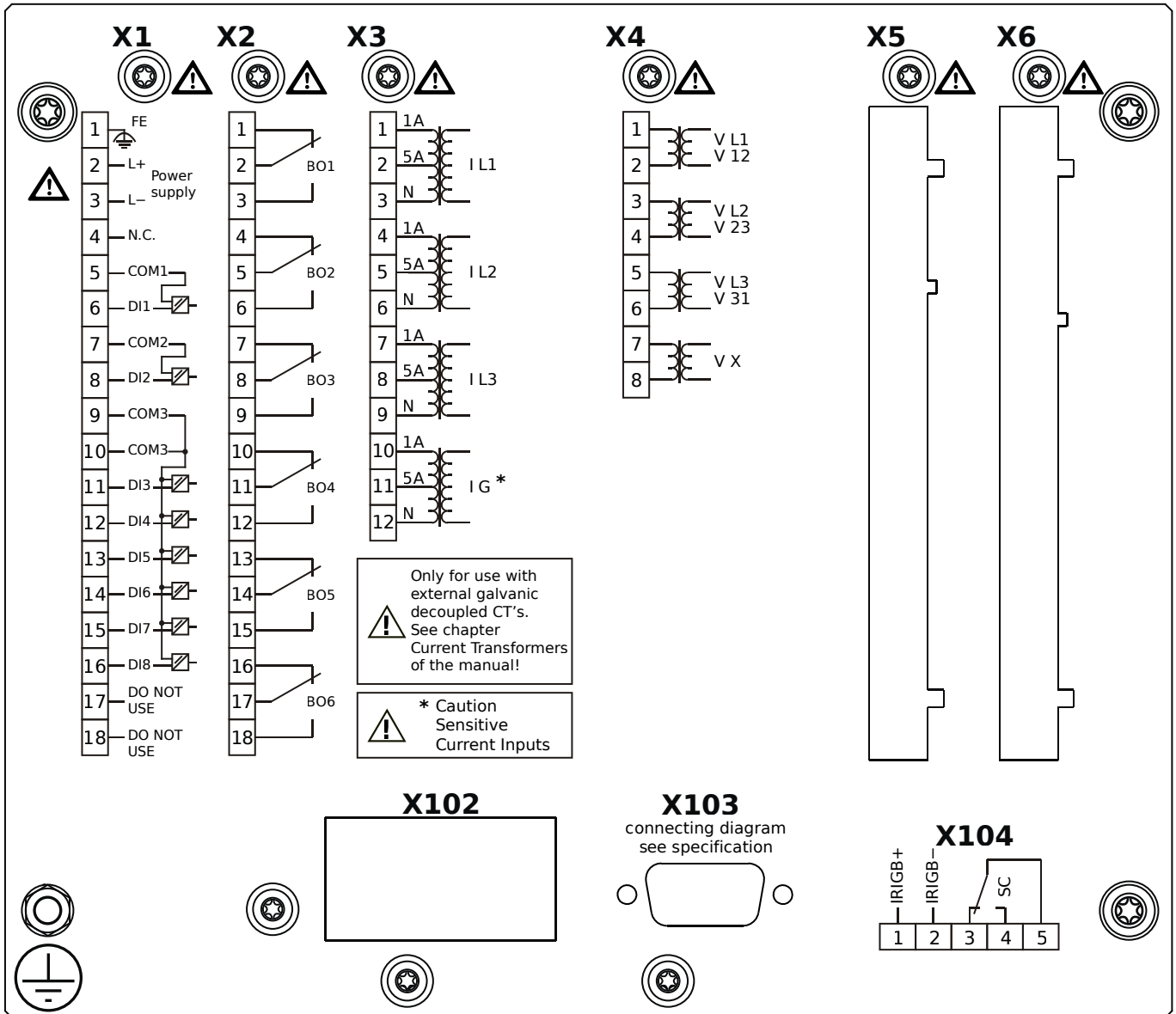

Housing B2, small display, 19" rack mounting

+ Conformal Coating (for installations in harsh environment)

- X1** – DI8-X1: Wide-range power supply unit, incl. 2 non-grouped digital inputs and 6 grouped digital inputs
- X2** – OR6: Assembly Group with 6 Output Relays (Changeover / Form C)
- X3** – TIs: Standard phase current measuring card and sensitive ground current measuring
- X4** – TU: Card with 4 voltage transformer measuring inputs (0 ... 800 VAC, under UL: 0 ... 600 VAC)
- X103** – Profibus-DP, RS485, D-SUB
- X104** – IRIG-B00X, incl. System Contact (Supervision Contact)

MRA4-2A1BFA

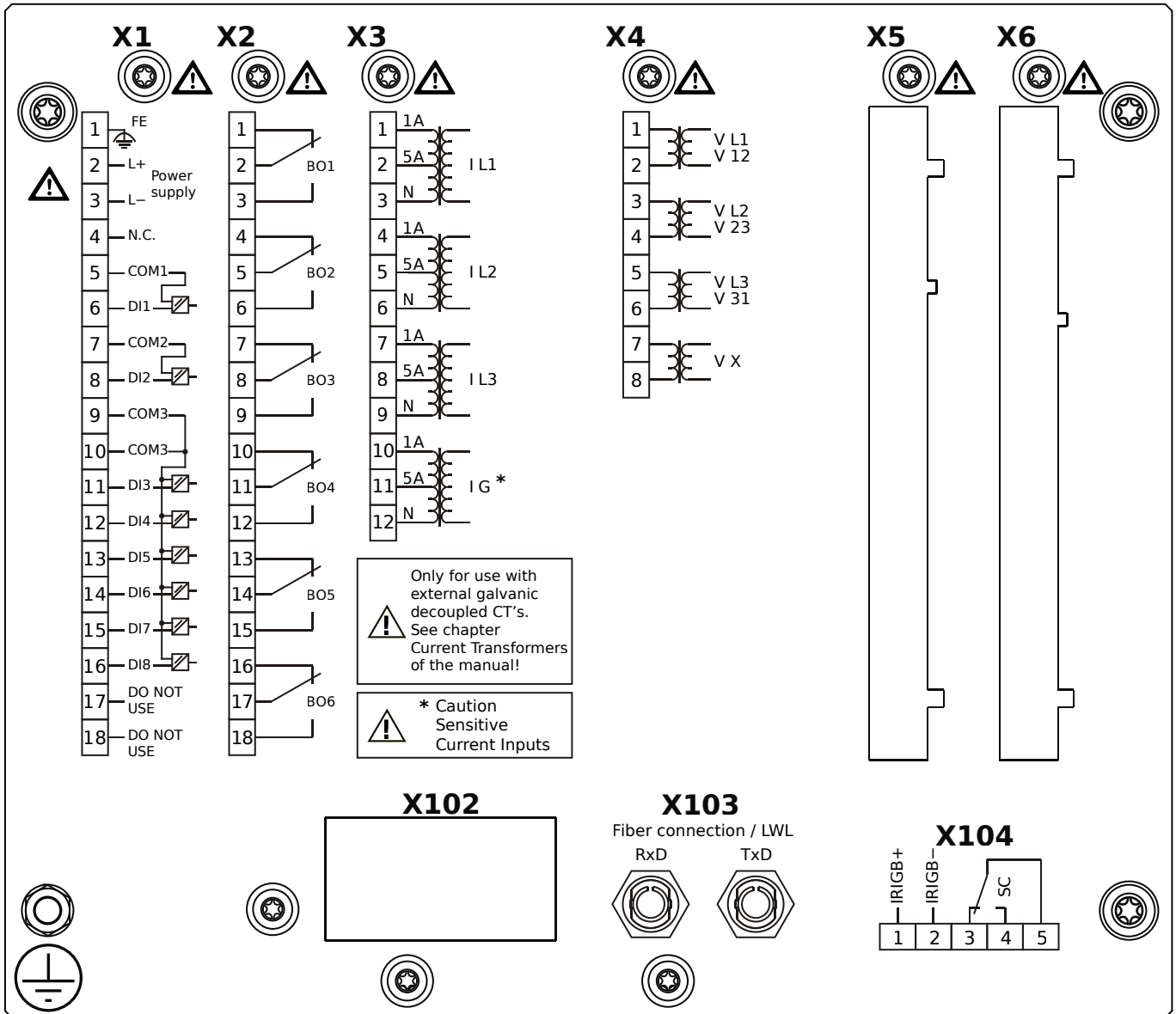

Housing B2, small display, 19" rack mounting

- X1** – DI8-X1: Wide-range power supply unit, incl. 2 non-grouped digital inputs and 6 grouped digital inputs
- X2** – OR6: Assembly Group with 6 Output Relays (Changeover / Form C)
- X3** – TIs: Standard phase current measuring card and sensitive ground current measuring
- X4** – TU: Card with 4 voltage transformer measuring inputs (0 ... 800 VAC, under UL: 0 ... 600 VAC)
- X103** – Modbus RTU / IEC 60870-5-103 / DNP3.0 RTU, Fiber optics interface, ST Connector
- X104** – IRIG-B00X, incl. System Contact (Supervision Contact)

MRA4-2A1BFB

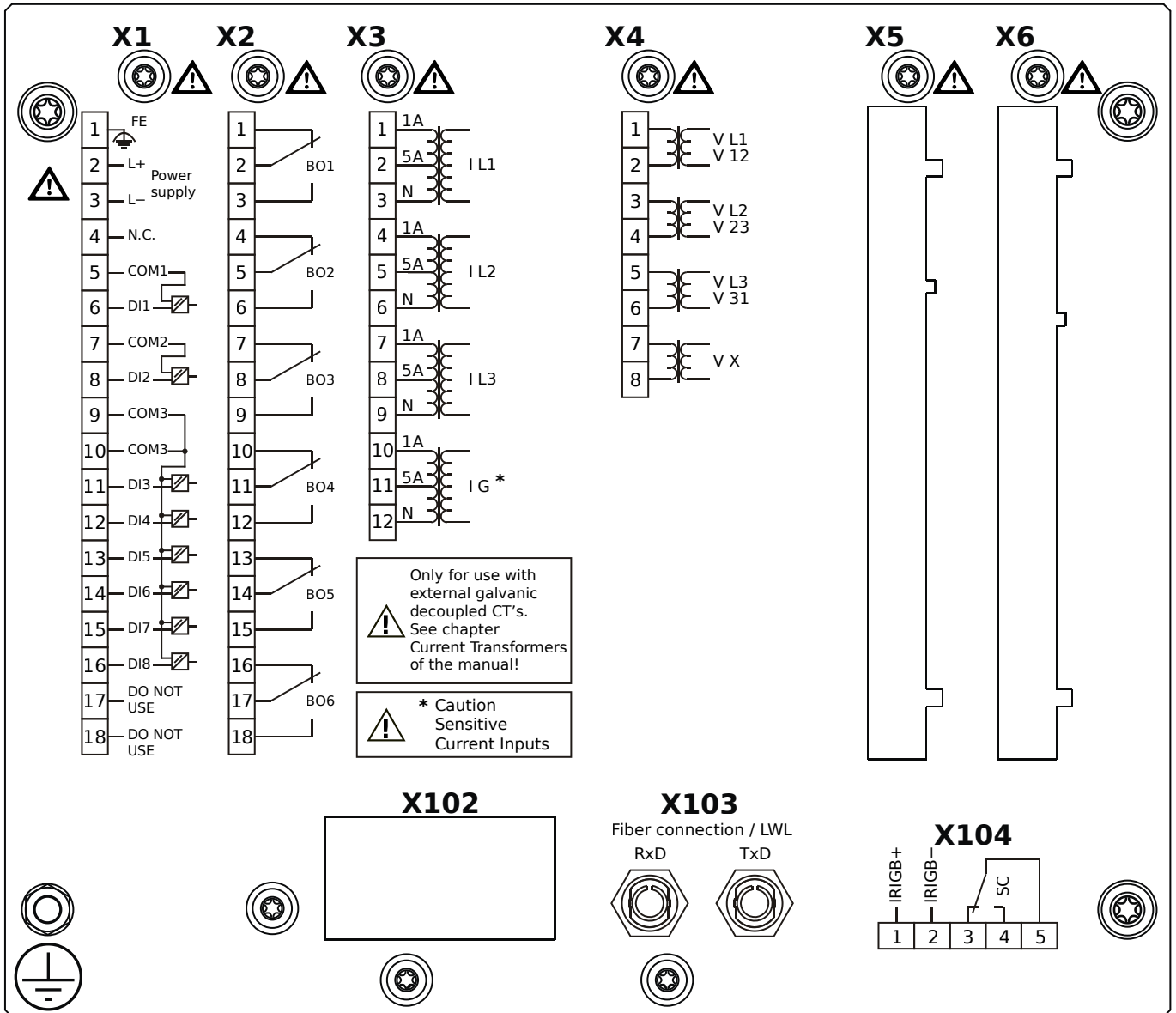

Housing B2, small display, 19" rack mounting

+ Conformal Coating (for installations in harsh environment)

- X1** – DI8-X1: Wide-range power supply unit, incl. 2 non-grouped digital inputs and 6 grouped digital inputs
- X2** – OR6: Assembly Group with 6 Output Relays (Changeover / Form C)
- X3** – TIs: Standard phase current measuring card and sensitive ground current measuring
- X4** – TU: Card with 4 voltage transformer measuring inputs (0 ... 800 VAC, under UL: 0 ... 600 VAC)
- X103** – Modbus RTU / IEC 60870-5-103 / DNP3.0 RTU, Fiber optics interface, ST Connector
- X104** – IRIG-B00X, incl. System Contact (Supervision Contact)

MRA4-2A1BGA

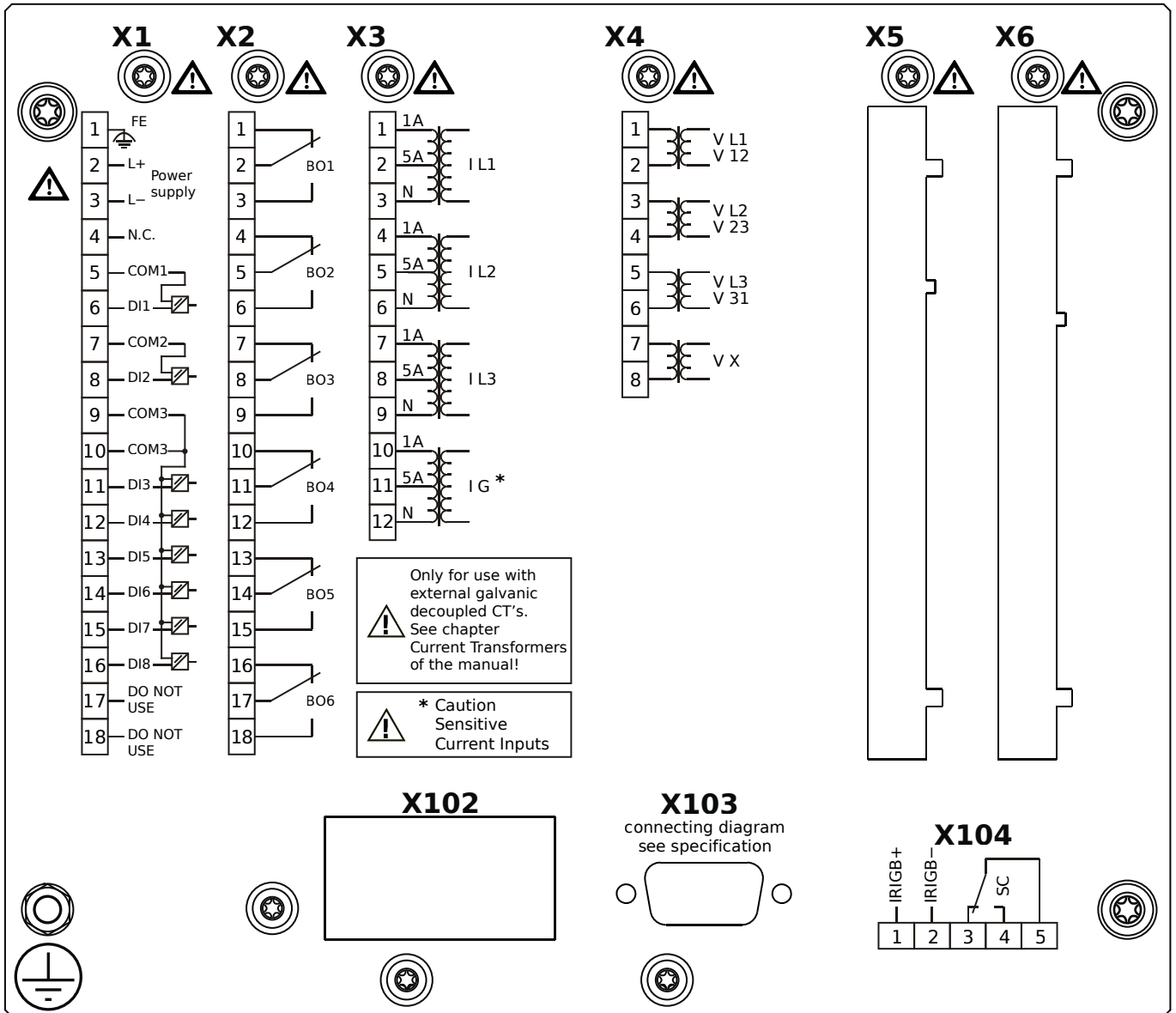

Housing B2, small display, 19" rack mounting

- X1** – DI8-X1: Wide-range power supply unit, incl. 2 non-grouped digital inputs and 6 grouped digital inputs
- X2** – OR6: Assembly Group with 6 Output Relays (Changeover / Form C)
- X3** – TIs: Standard phase current measuring card and sensitive ground current measuring
- X4** – TU: Card with 4 voltage transformer measuring inputs (0 ... 800 VAC, under UL: 0 ... 600 VAC)
- X103** – Modbus RTU / IEC 60870-5-103 / DNP3.0 RTU, RS485, D-SUB
- X104** – IRIG-B00X, incl. System Contact (Supervision Contact)

MRA4-2A1BGB

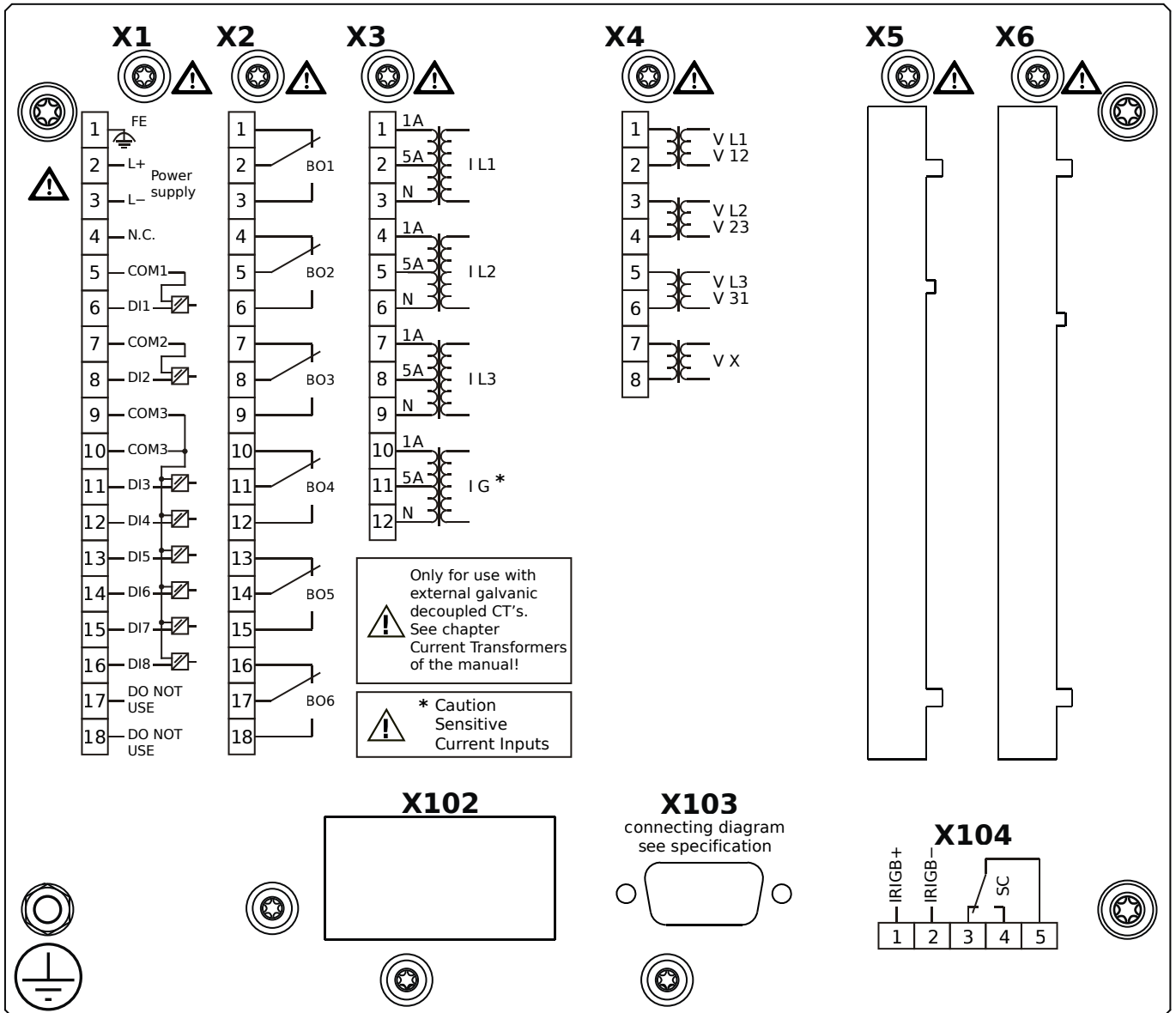

Housing B2, small display, 19" rack mounting

+ Conformal Coating (for installations in harsh environment)

- X1** – DI8-X1: Wide-range power supply unit, incl. 2 non-grouped digital inputs and 6 grouped digital inputs
- X2** – OR6: Assembly Group with 6 Output Relays (Changeover / Form C)
- X3** – TIs: Standard phase current measuring card and sensitive ground current measuring
- X4** – TU: Card with 4 voltage transformer measuring inputs (0 ... 800 VAC, under UL: 0 ... 600 VAC)
- X103** – Modbus RTU / IEC 60870-5-103 / DNP3.0 RTU, RS485, D-SUB
- X104** – IRIG-B00X, incl. System Contact (Supervision Contact)

MRA4-2A1BHA

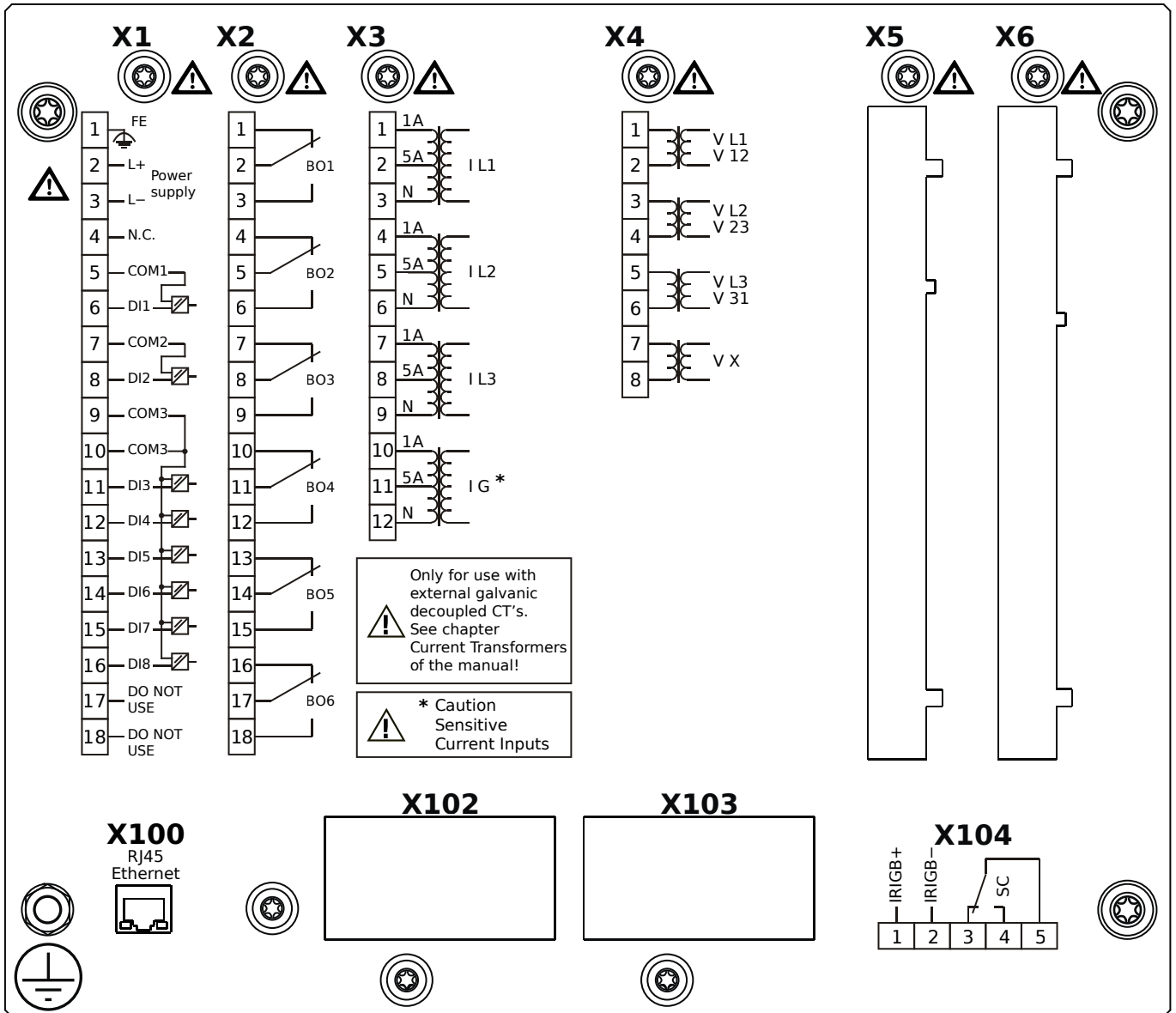

Housing B2, small display, 19" rack mounting

- X1** – DI8-X1: Wide-range power supply unit, incl. 2 non-grouped digital inputs and 6 grouped digital inputs
- X2** – OR6: Assembly Group with 6 Output Relays (Changeover / Form C)
- X3** – TIs: Standard phase current measuring card and sensitive ground current measuring
- X4** – TU: Card with 4 voltage transformer measuring inputs (0 ... 800 VAC, under UL: 0 ... 600 VAC)
- X100** – IEC 61850 / Modbus TCP / DNP3.0 TCP/UDP, Ethernet interface, 100 Mbit/s, RJ45 (BASE100-FX)
- X104** – IRIG-B00X, incl. System Contact (Supervision Contact)

MRA4-2A1BHB

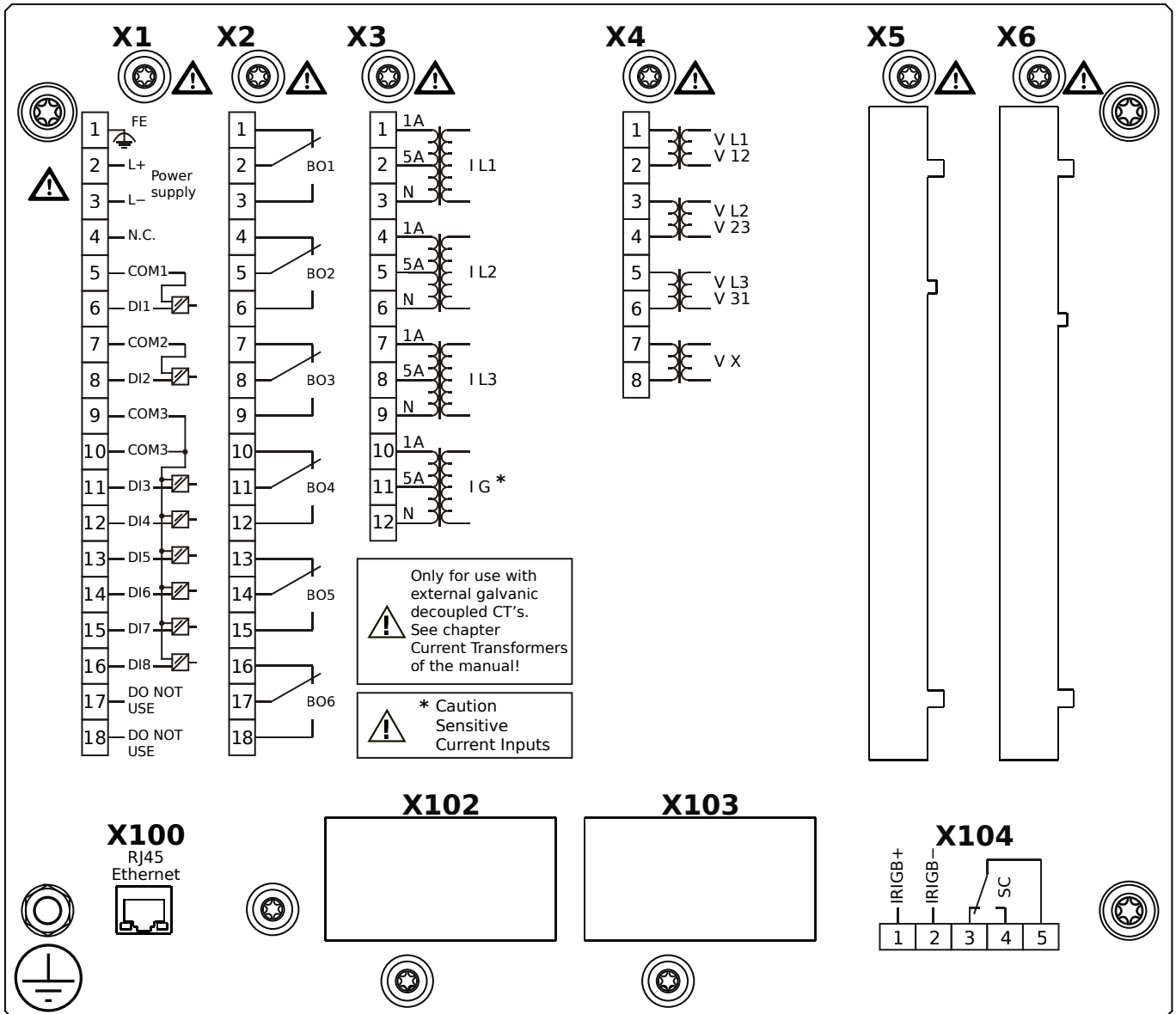

Housing B2, small display, 19" rack mounting

+ Conformal Coating (for installations in harsh environment)

- X1** – DI8-X1: Wide-range power supply unit, incl. 2 non-grouped digital inputs and 6 grouped digital inputs
- X2** – OR6: Assembly Group with 6 Output Relays (Changeover / Form C)
- X3** – TIs: Standard phase current measuring card and sensitive ground current measuring
- X4** – TU: Card with 4 voltage transformer measuring inputs (0 ... 800 VAC, under UL: 0 ... 600 VAC)
- X100** – IEC 61850 / Modbus TCP / DNP3.0 TCP/UDP, Ethernet interface, 100 Mbit/s, RJ45 (BASE100-FX)
- X104** – IRIG-B00X, incl. System Contact (Supervision Contact)

MRA4-2A1BIA

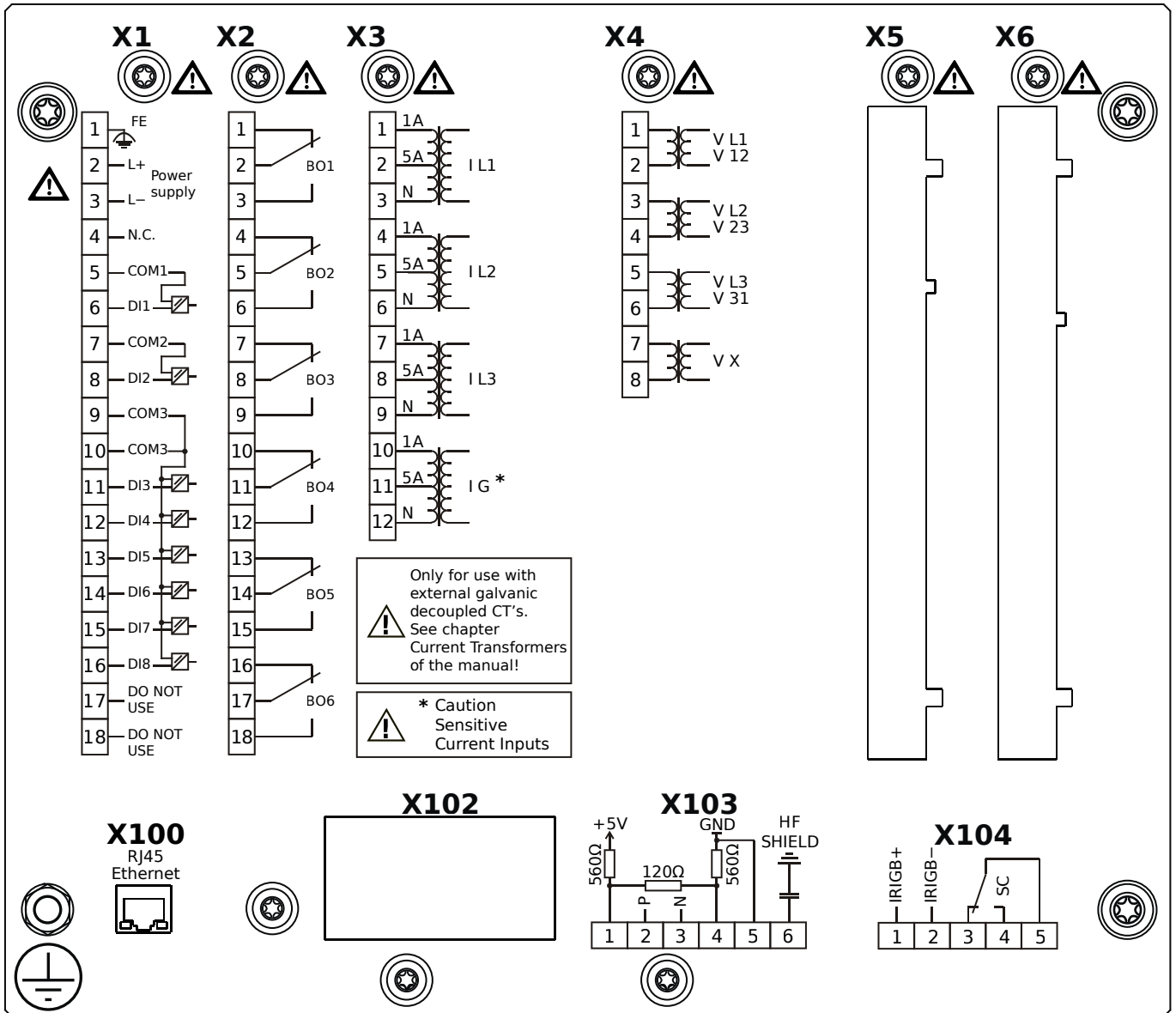

Housing B2, small display, 19" rack mounting

- X1** – DI8-X1: Wide-range power supply unit, incl. 2 non-grouped digital inputs and 6 grouped digital inputs
- X2** – OR6: Assembly Group with 6 Output Relays (Changeover / Form C)
- X3** – TIs: Standard phase current measuring card and sensitive ground current measuring
- X4** – TU: Card with 4 voltage transformer measuring inputs (0 ... 800 VAC, under UL: 0 ... 600 VAC)
- X100** – Modbus TCP / DNP3.0 TCP/UDP, Ethernet interface, 100 Mbit/s, RJ45 (BASE100-FX)
- X103** – IEC 60870-5-103 / Modbus RTU / DNP3.0 RTU, RS485, Terminals
- X104** – IRIG-B00X, incl. System Contact (Supervision Contact)

MRA4-2A1BIB

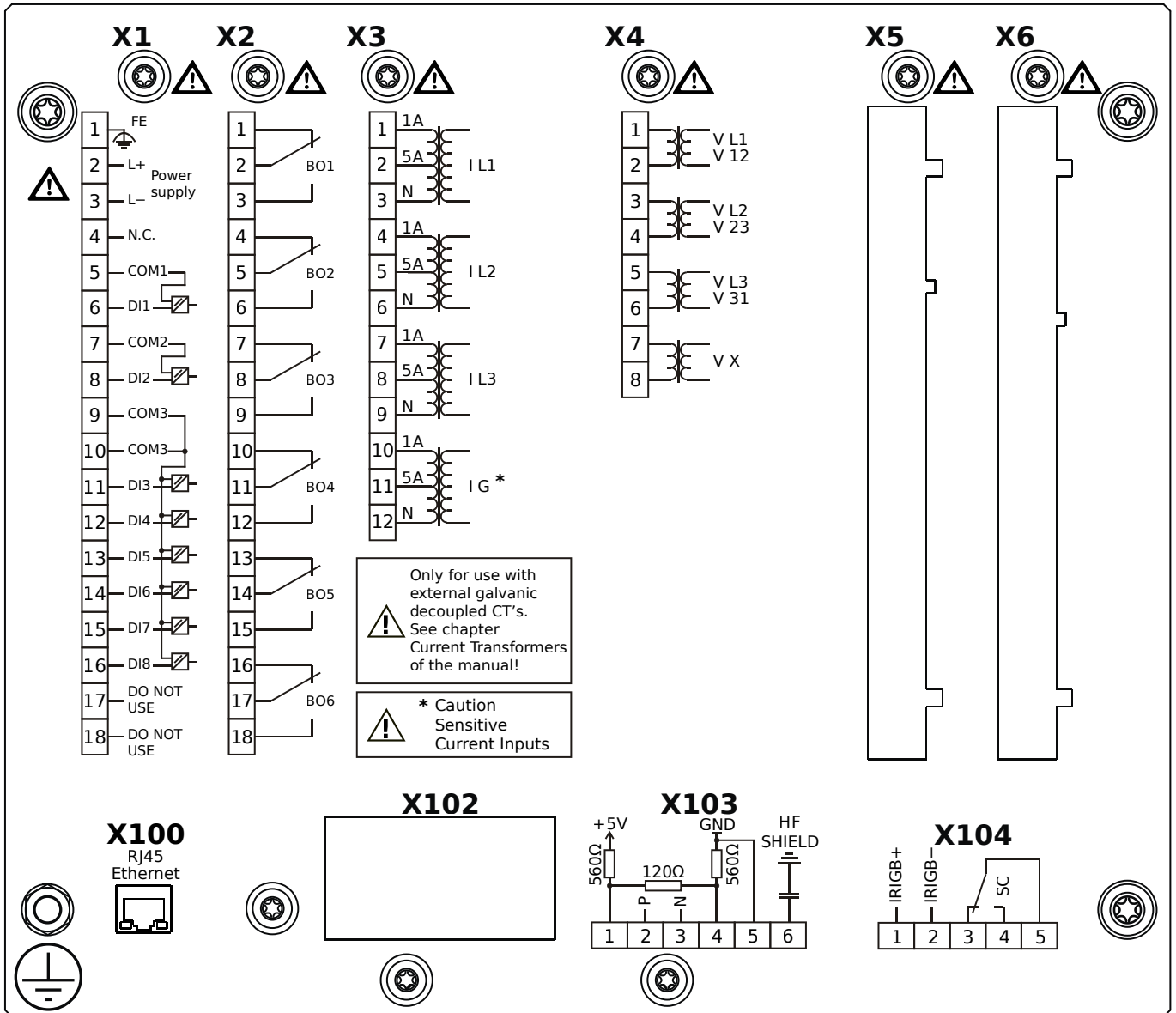

Housing B2, small display, 19" rack mounting

+ Conformal Coating (for installations in harsh environment)

- X1** – DI8-X1: Wide-range power supply unit, incl. 2 non-grouped digital inputs and 6 grouped digital inputs
- X2** – OR6: Assembly Group with 6 Output Relays (Changeover / Form C)
- X3** – TIs: Standard phase current measuring card and sensitive ground current measuring
- X4** – TU: Card with 4 voltage transformer measuring inputs (0 ... 800 VAC, under UL: 0 ... 600 VAC)
- X100** – Modbus TCP / DNP3.0 TCP/UDP, Ethernet interface, 100 Mbit/s, RJ45 (BASE100-FX)
- X103** – IEC 60870-5-103 / Modbus RTU / DNP3.0 RTU, RS485, Terminals
- X104** – IRIG-B00X, incl. System Contact (Supervision Contact)

MRA4-2A1BKA

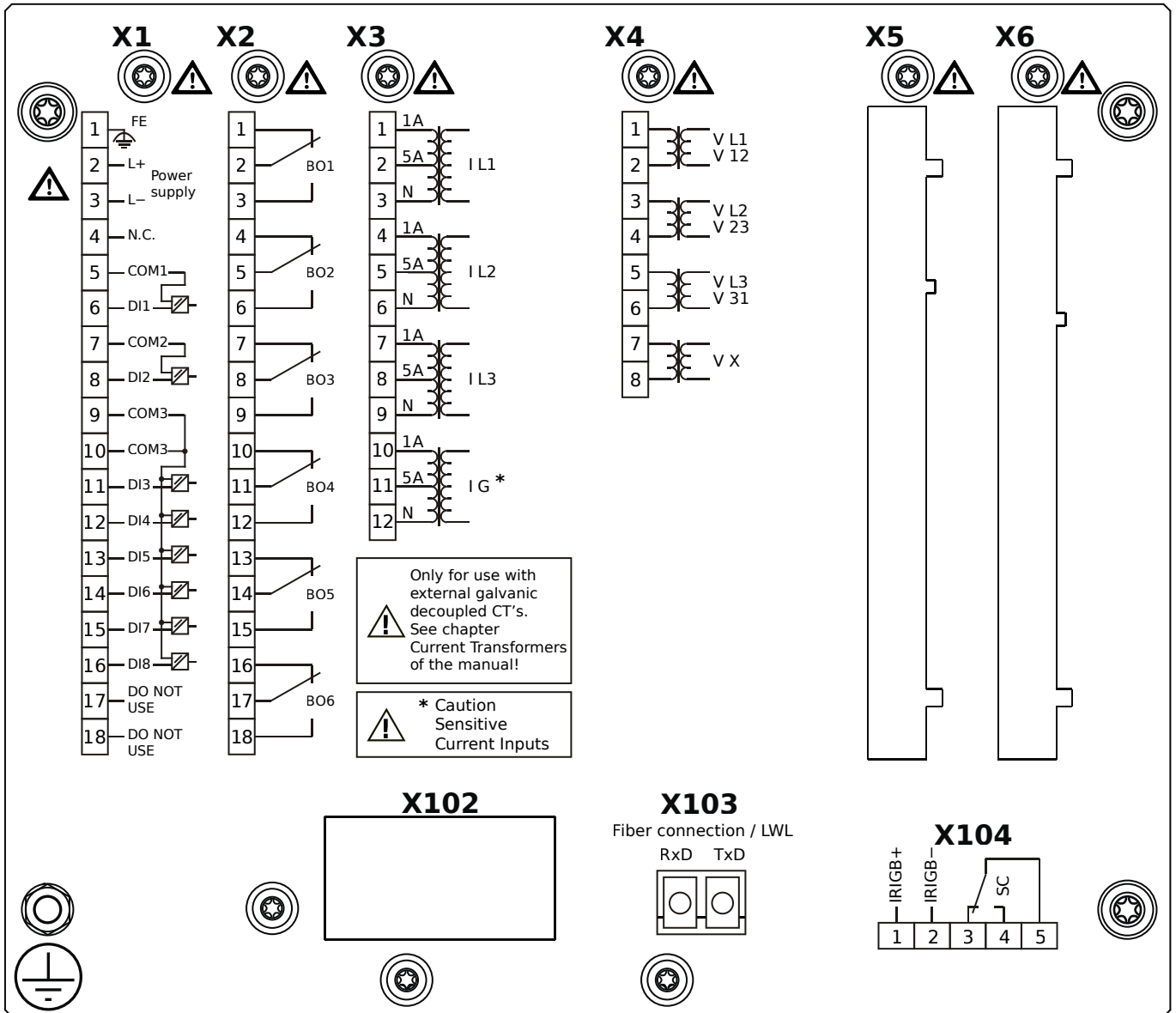

Housing B2, small display, 19" rack mounting

- X1** – DI8-X1: Wide-range power supply unit, incl. 2 non-grouped digital inputs and 6 grouped digital inputs
- X2** – OR6: Assembly Group with 6 Output Relays (Changeover / Form C)
- X3** – TIs: Standard phase current measuring card and sensitive ground current measuring
- X4** – TU: Card with 4 voltage transformer measuring inputs (0 ... 800 VAC, under UL: 0 ... 600 VAC)
- X103** – IEC 61850 / Modbus TCP / DNP3.0 TCP/UDP, Fiber optics interface, LC Connector
- X104** – IRIG-B00X, incl. System Contact (Supervision Contact)

MRA4-2A1BKB

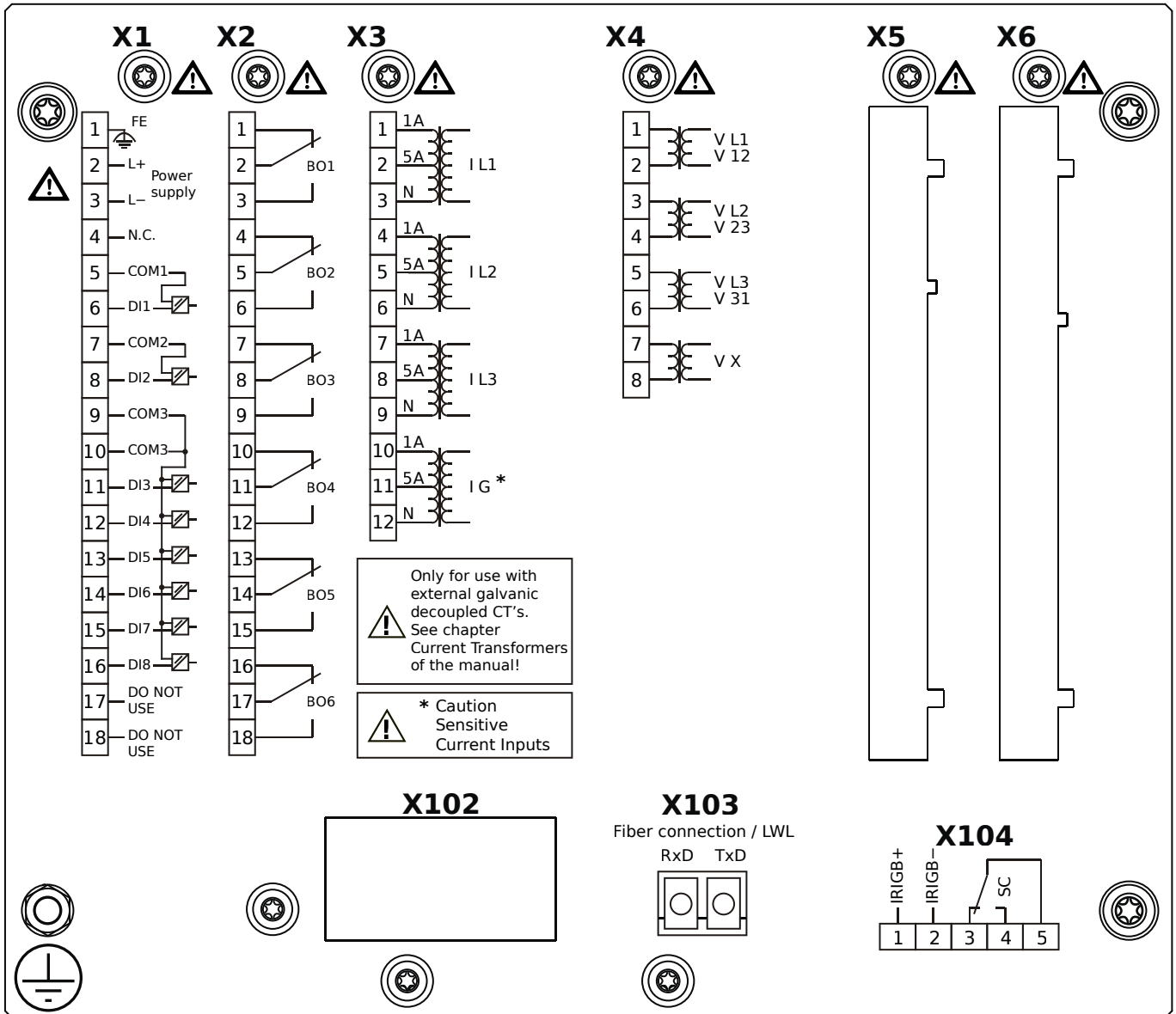

Housing B2, small display, 19" rack mounting

+ Conformal Coating (for installations in harsh environment)

- X1** – DI8-X1: Wide-range power supply unit, incl. 2 non-grouped digital inputs and 6 grouped digital inputs
- X2** – OR6: Assembly Group with 6 Output Relays (Changeover / Form C)
- X3** – TIs: Standard phase current measuring card and sensitive ground current measuring
- X4** – TU: Card with 4 voltage transformer measuring inputs (0 ... 800 VAC, under UL: 0 ... 600 VAC)
- X103** – IEC 61850 / Modbus TCP / DNP3.0 TCP/UDP, Fiber optics interface, LC Connector
- X104** – IRIG-B00X, incl. System Contact (Supervision Contact)

MRA4-2A1BLA

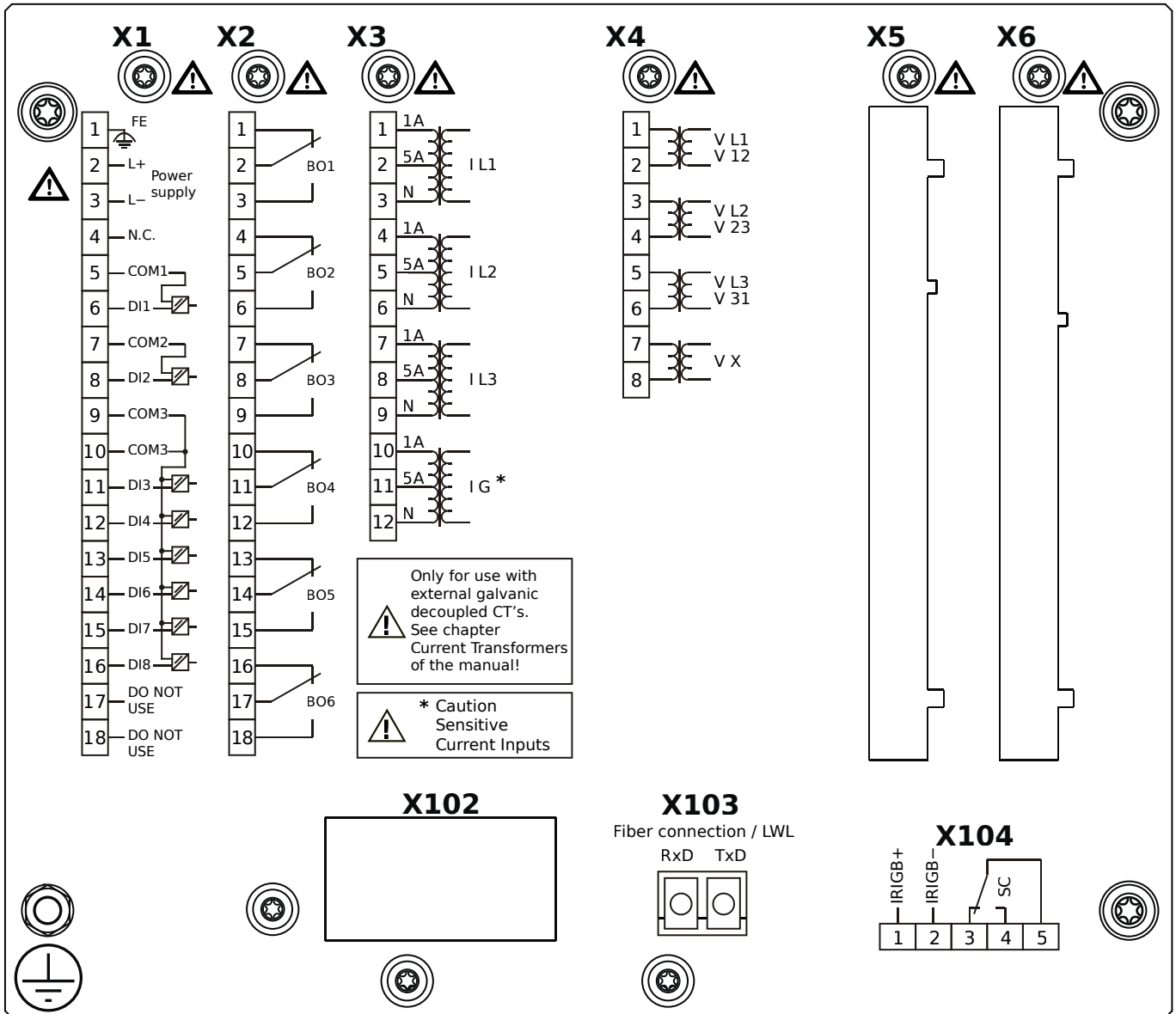

Housing B2, small display, 19" rack mounting

- X1** – DI8-X1: Wide-range power supply unit, incl. 2 non-grouped digital inputs and 6 grouped digital inputs
- X2** – OR6: Assembly Group with 6 Output Relays (Changeover / Form C)
- X3** – TIs: Standard phase current measuring card and sensitive ground current measuring
- X4** – TU: Card with 4 voltage transformer measuring inputs (0 ... 800 VAC, under UL: 0 ... 600 VAC)
- X103** – Modbus TCP / DNP3.0 TCP/UDP, Fiber optics interface, LC Connector
- X104** – IRIG-B00X, incl. System Contact (Supervision Contact)

MRA4-2A1BLB

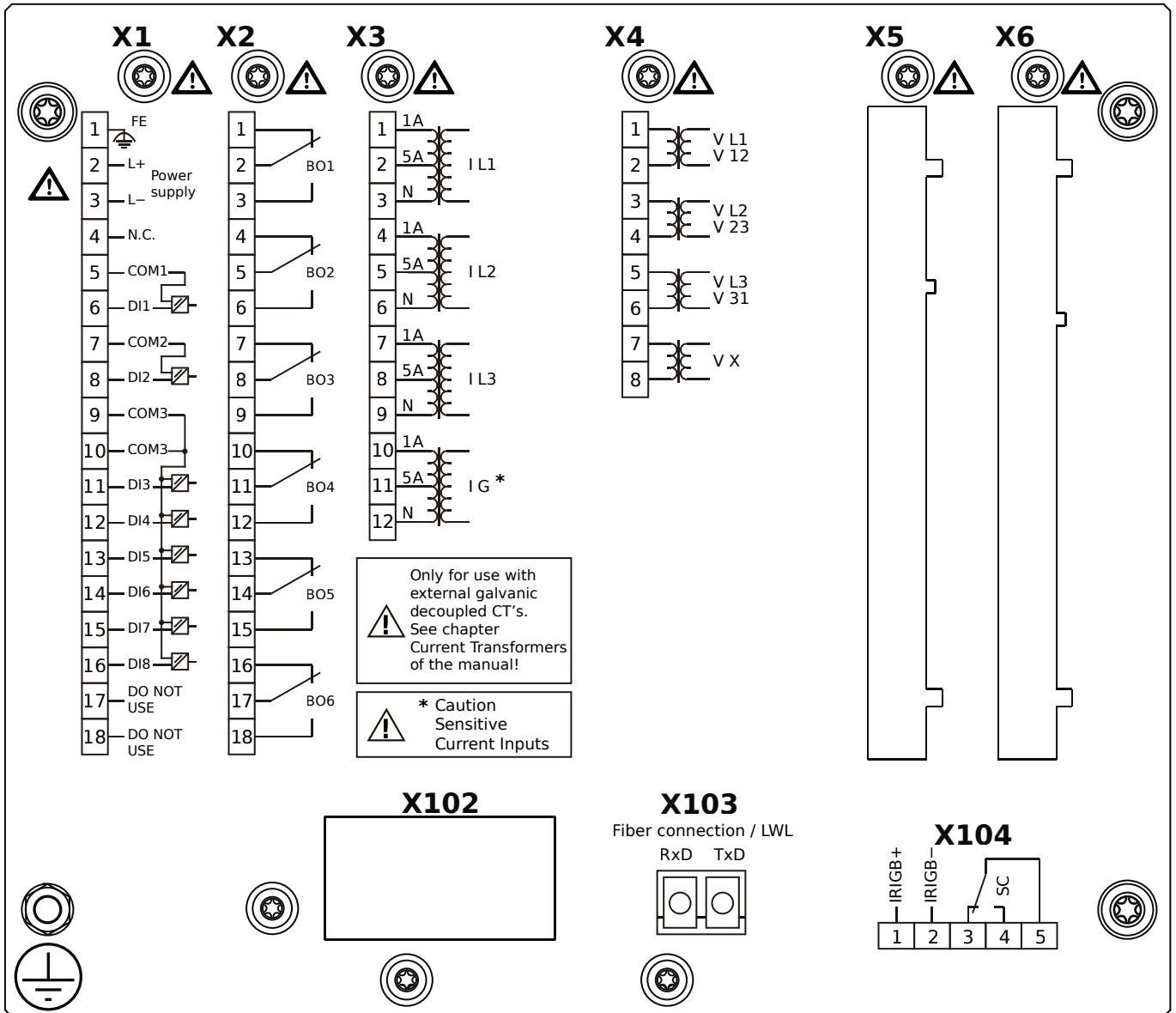

Housing B2, small display, 19" rack mounting

+ Conformal Coating (for installations in harsh environment)

- X1** – DI8-X1: Wide-range power supply unit, incl. 2 non-grouped digital inputs and 6 grouped digital inputs
- X2** – OR6: Assembly Group with 6 Output Relays (Changeover / Form C)
- X3** – TIs: Standard phase current measuring card and sensitive ground current measuring
- X4** – TU: Card with 4 voltage transformer measuring inputs (0 ... 800 VAC, under UL: 0 ... 600 VAC)
- X103** – Modbus TCP / DNP3.0 TCP/UDP, Fiber optics interface, LC Connector
- X104** – IRIG-B00X, incl. System Contact (Supervision Contact)

MRA4-2A1BTA

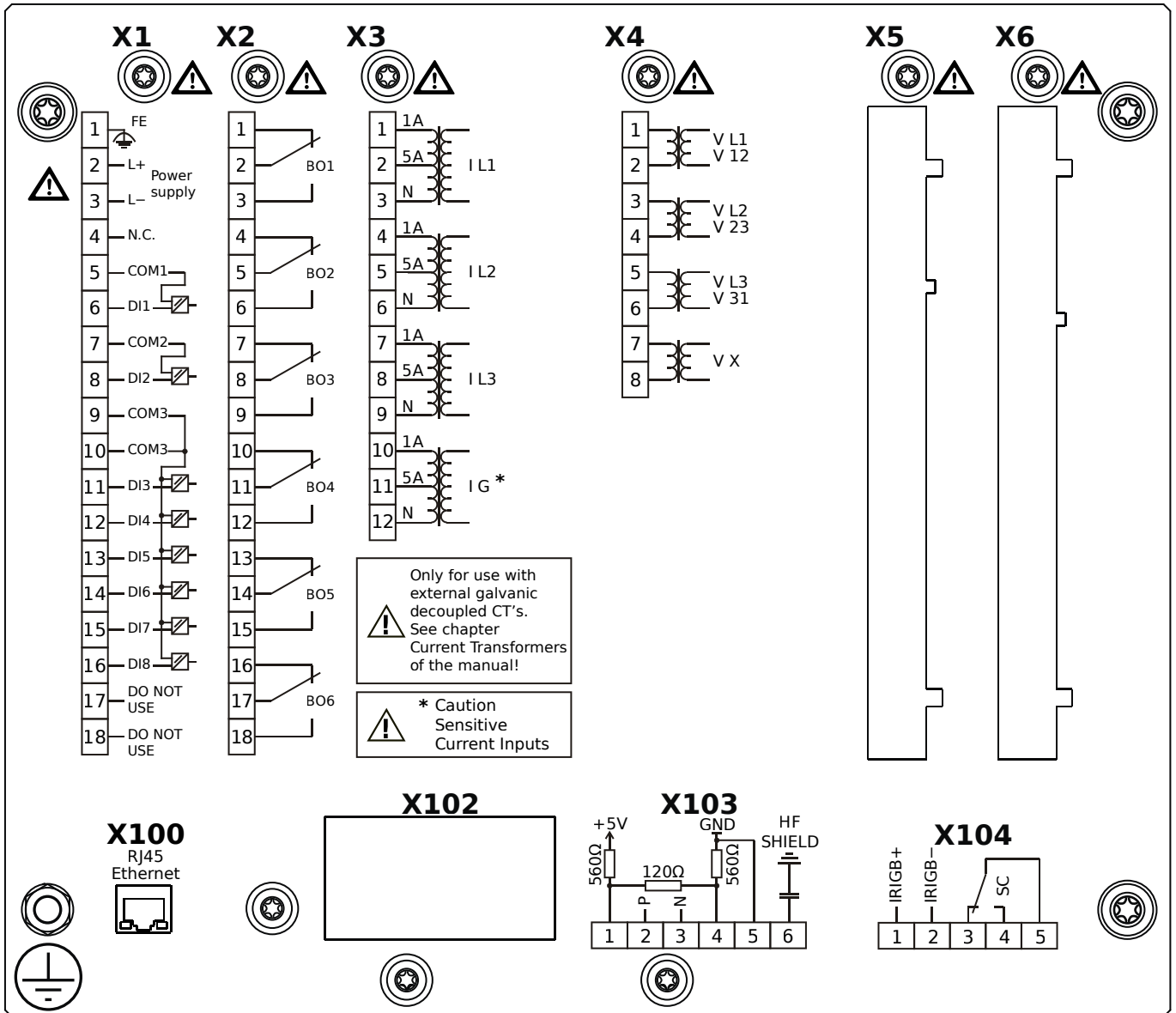

Housing B2, small display, 19" rack mounting

- X1** – DI8-X1: Wide-range power supply unit, incl. 2 non-grouped digital inputs and 6 grouped digital inputs
- X2** – OR6: Assembly Group with 6 Output Relays (Changeover / Form C)
- X3** – TIs: Standard phase current measuring card and sensitive ground current measuring
- X4** – TU: Card with 4 voltage transformer measuring inputs (0 ... 800 VAC, under UL: 0 ... 600 VAC)
- X100** – IEC 61850 / Modbus TCP / DNP3.0 TCP/UDP, Ethernet interface, 100 Mbit/s, RJ45 (BASE100-FX)
- X103** – IEC 60870-5-103 / Modbus RTU / DNP3.0 RTU, RS485, Terminals
- X104** – IRIG-B00X, incl. System Contact (Supervision Contact)

MRA4-2A1BTB

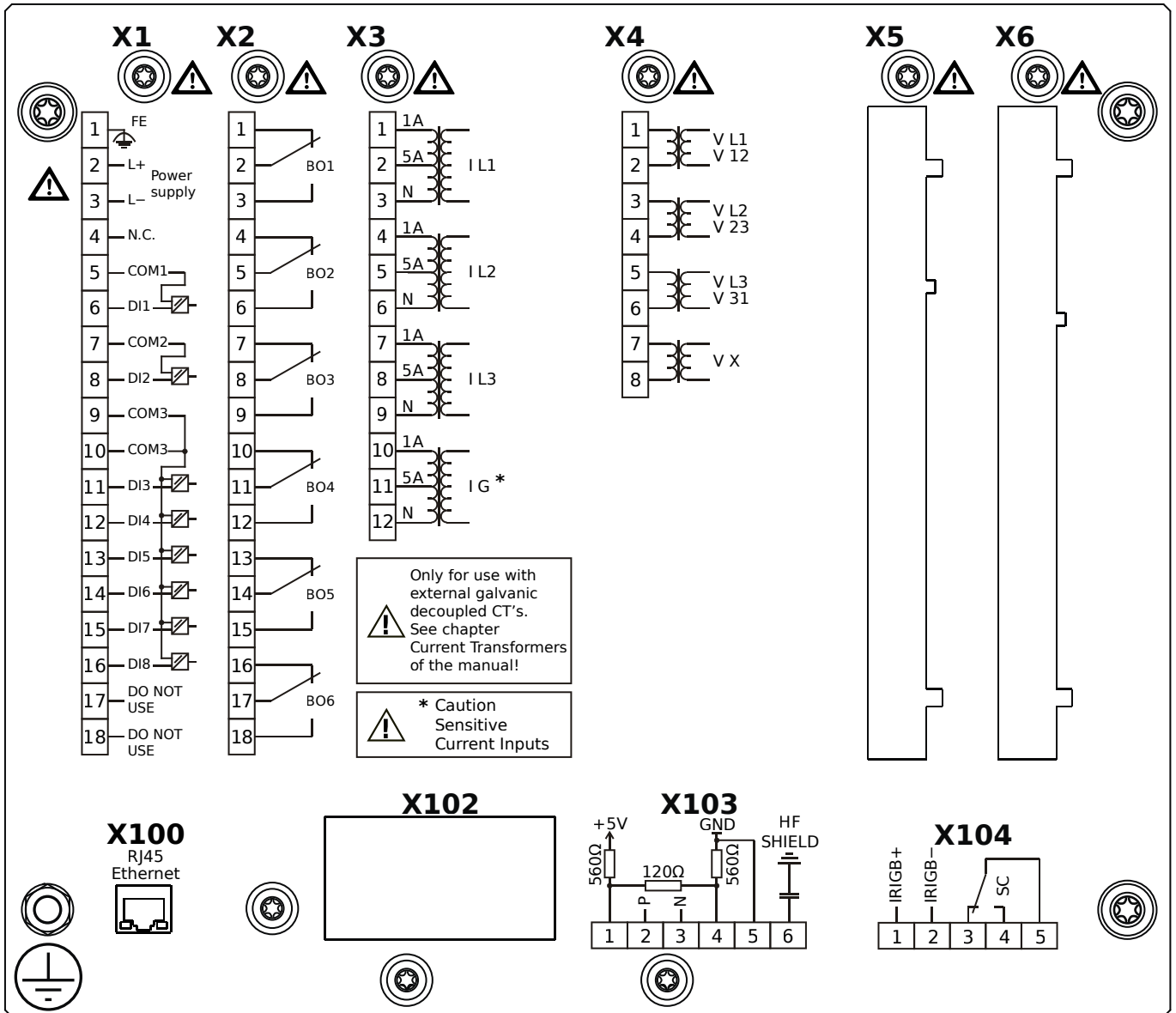

Housing B2, small display, 19" rack mounting

+ Conformal Coating (for installations in harsh environment)

- X1** – DI8-X1: Wide-range power supply unit, incl. 2 non-grouped digital inputs and 6 grouped digital inputs
- X2** – OR6: Assembly Group with 6 Output Relays (Changeover / Form C)
- X3** – TIs: Standard phase current measuring card and sensitive ground current measuring
- X4** – TU: Card with 4 voltage transformer measuring inputs (0 ... 800 VAC, under UL: 0 ... 600 VAC)
- X100** – IEC 61850 / Modbus TCP / DNP3.0 TCP/UDP, Ethernet interface, 100 Mbit/s, RJ45 (BASE100-FX)
- X103** – IEC 60870-5-103 / Modbus RTU / DNP3.0 RTU, RS485, Terminals
- X104** – IRIG-B00X, incl. System Contact (Supervision Contact)

MRA4-2D0AAA

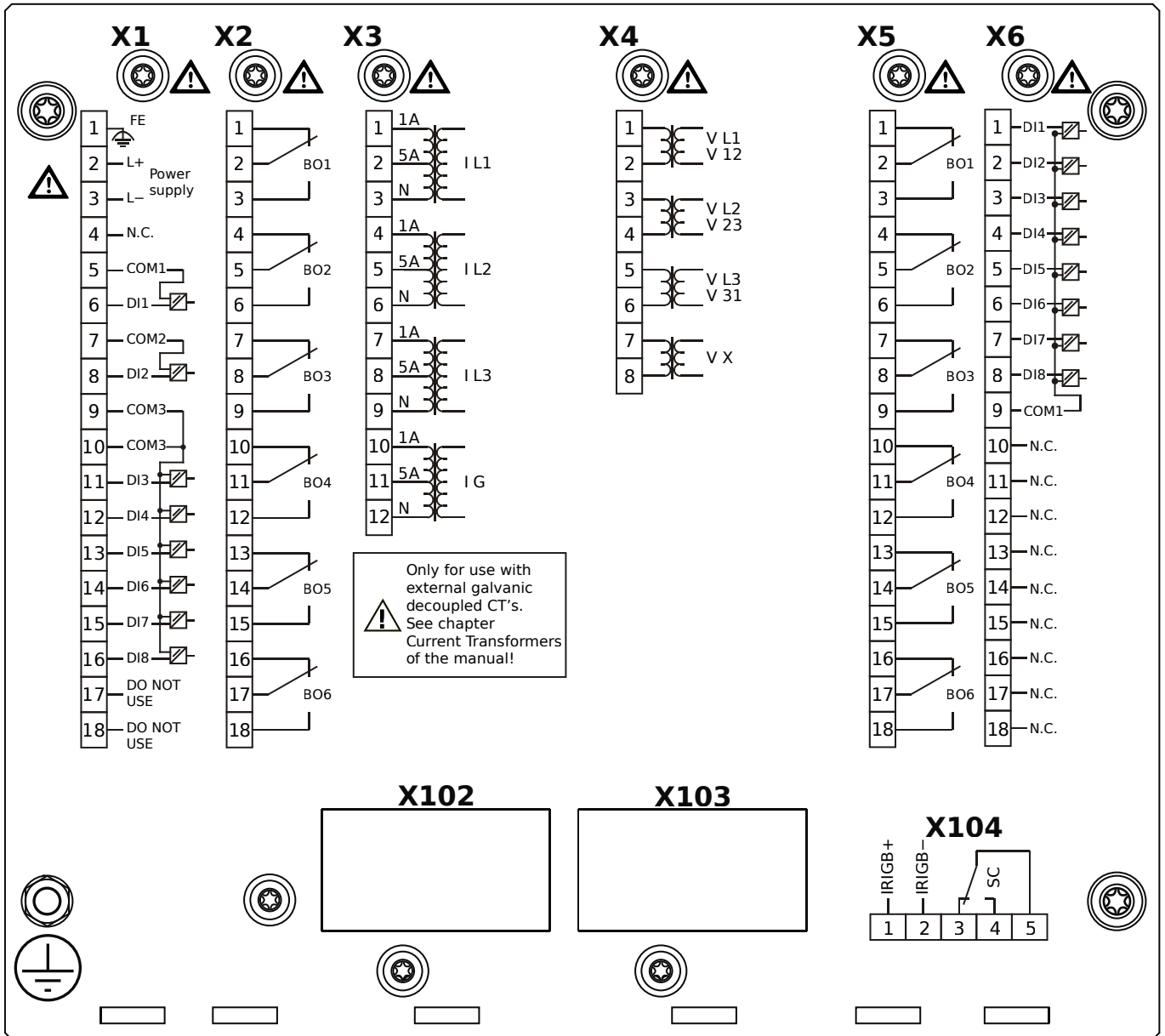

Housing B2, small display, door mounting

- X1** – DI8-X1: Wide-range power supply unit, incl. 2 non-grouped digital inputs and 6 grouped digital inputs
- X2** – OR6: Assembly Group with 6 Output Relays (Changeover / Form C)
- X3** – TI: Standard current measuring card
- X4** – TU: Card with 4 voltage transformer measuring inputs (0 ... 800 VAC, under UL: 0 ... 600 VAC)
- X5** – OR6: Assembly Group with 6 Output Relays (Changeover / Form C)
- X6** – DI8: Assembly Group with 8 Digital Inputs
- X104** – IRIG-B00X, incl. System Contact (Supervision Contact)

MRA4-2D0AAB

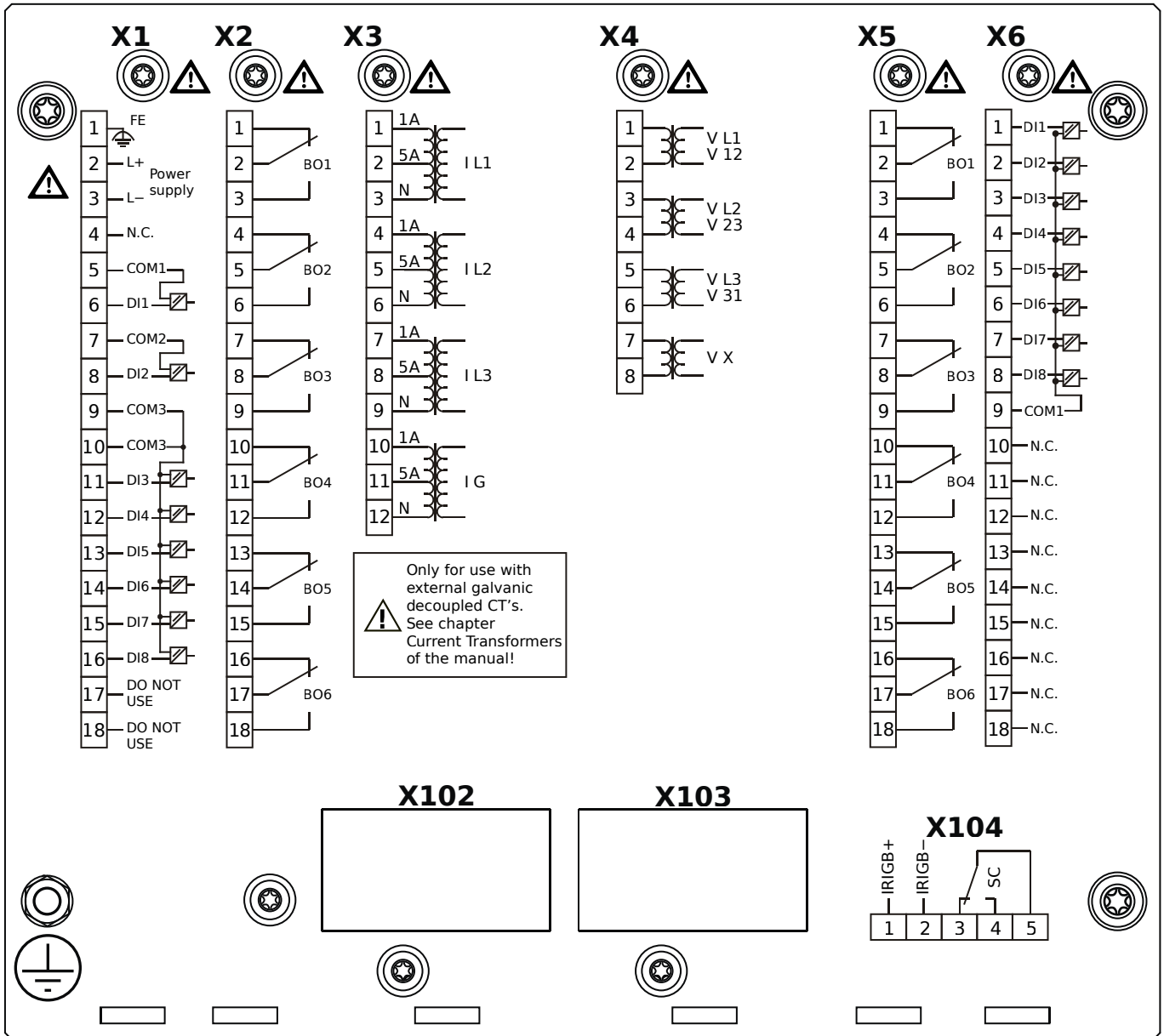

Housing B2, small display, door mounting

+ Conformal Coating (for installations in harsh environment)

- X1** – DI8-X1: Wide-range power supply unit, incl. 2 non-grouped digital inputs and 6 grouped digital inputs
- X2** – OR6: Assembly Group with 6 Output Relays (Changeover / Form C)
- X3** – TI: Standard current measuring card
- X4** – TU: Card with 4 voltage transformer measuring inputs (0 ... 800 VAC, under UL: 0 ... 600 VAC)
- X5** – OR6: Assembly Group with 6 Output Relays (Changeover / Form C)
- X6** – DI8: Assembly Group with 8 Digital Inputs
- X104** – IRIG-B00X, incl. System Contact (Supervision Contact)

MRA4-2D0ABA

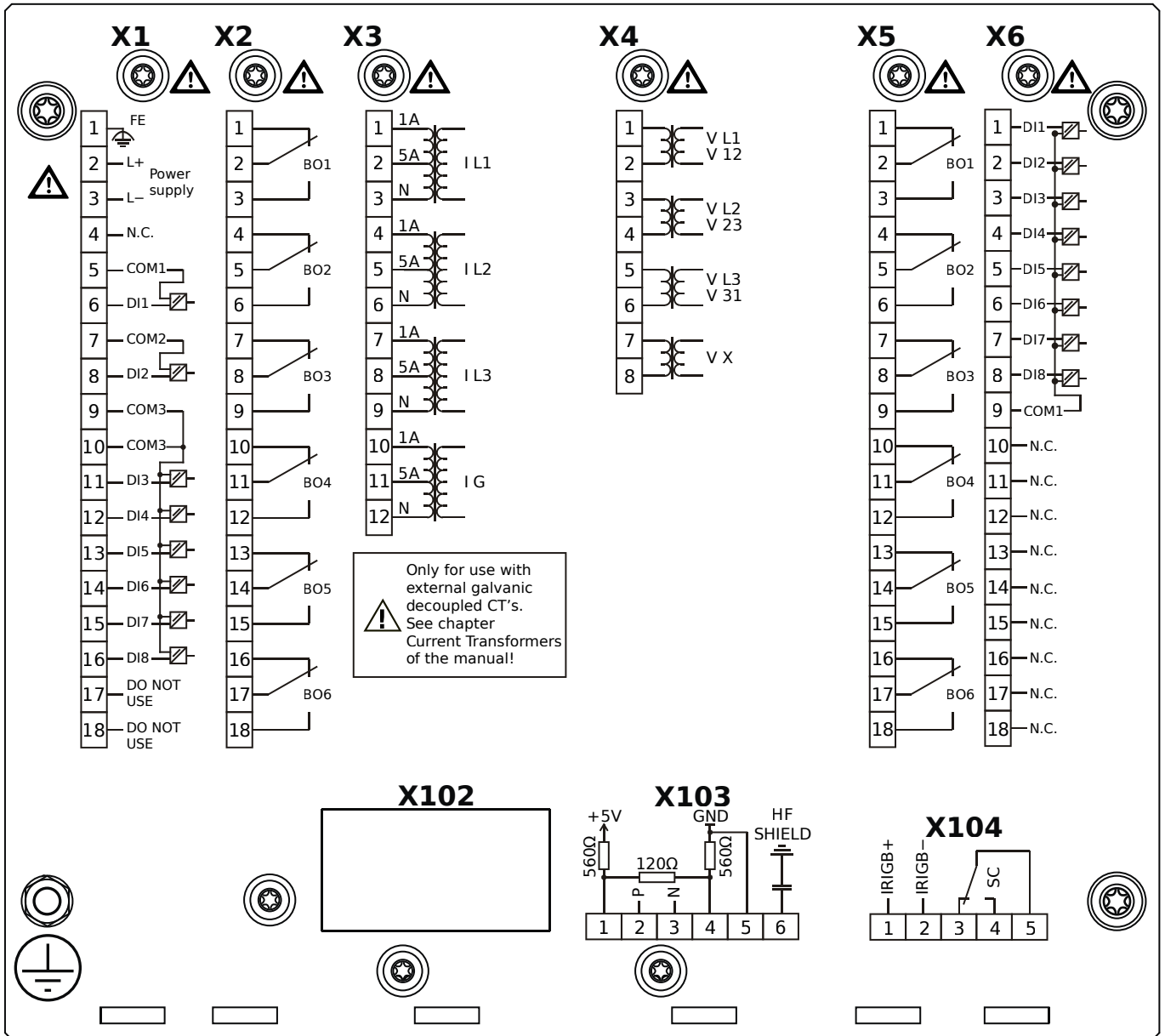

Housing B2, small display, door mounting

- X1** – DI8-X1: Wide-range power supply unit, incl. 2 non-grouped digital inputs and 6 grouped digital inputs
- X2** – OR6: Assembly Group with 6 Output Relays (Changeover / Form C)
- X3** – TI: Standard current measuring card
- X4** – TU: Card with 4 voltage transformer measuring inputs (0 ... 800 VAC, under UL: 0 ... 600 VAC)
- X5** – OR6: Assembly Group with 6 Output Relays (Changeover / Form C)
- X6** – DI8: Assembly Group with 8 Digital Inputs
- X103** – Modbus RTU / IEC 60870-5-103 / DNP3.0 RTU, RS485, Terminals
- X104** – IRIG-B00X, incl. System Contact (Supervision Contact)

MRA4-2D0ABB

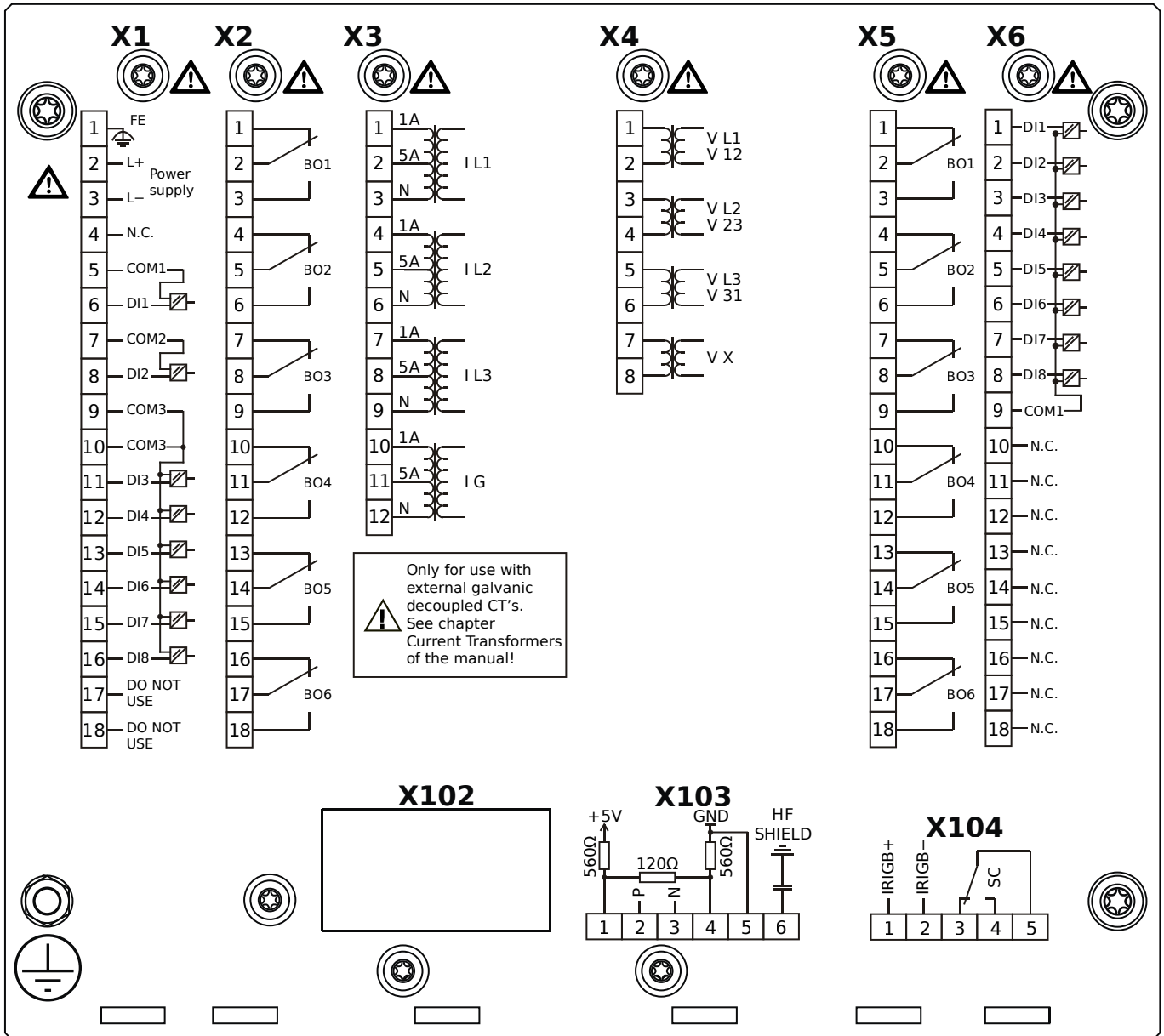

Housing B2, small display, door mounting

+ Conformal Coating (for installations in harsh environment)

- X1** – DI8-X1: Wide-range power supply unit, incl. 2 non-grouped digital inputs and 6 grouped digital inputs
- X2** – OR6: Assembly Group with 6 Output Relays (Changeover / Form C)
- X3** – TI: Standard current measuring card
- X4** – TU: Card with 4 voltage transformer measuring inputs (0 ... 800 VAC, under UL: 0 ... 600 VAC)
- X5** – OR6: Assembly Group with 6 Output Relays (Changeover / Form C)
- X6** – DI8: Assembly Group with 8 Digital Inputs
- X103** – Modbus RTU / IEC 60870-5-103 / DNP3.0 RTU, RS485, Terminals
- X104** – IRIG-B00X, incl. System Contact (Supervision Contact)

MRA4-2D0ACA

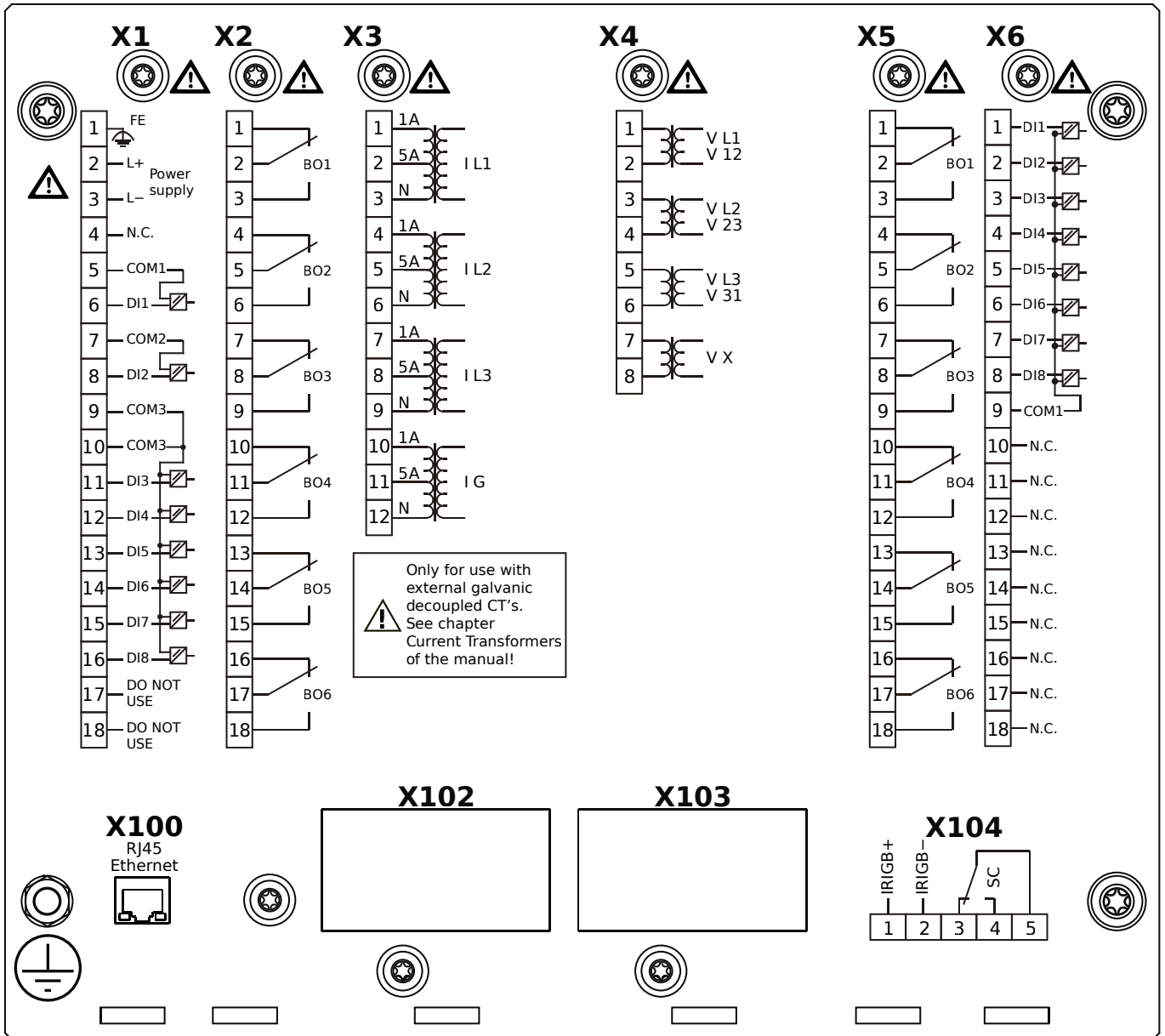

Housing B2, small display, door mounting

- X1** – DI8-X1: Wide-range power supply unit, incl. 2 non-grouped digital inputs and 6 grouped digital inputs
- X2** – OR6: Assembly Group with 6 Output Relays (Changeover / Form C)
- X3** – TI: Standard current measuring card
- X4** – TU: Card with 4 voltage transformer measuring inputs (0 ... 800 VAC, under UL: 0 ... 600 VAC)
- X5** – OR6: Assembly Group with 6 Output Relays (Changeover / Form C)
- X6** – DI8: Assembly Group with 8 Digital Inputs
- X100** – Modbus TCP / DNP3.0 TCP/UDP, Ethernet interface, 100 Mbit/s, RJ45 (BASE100-FX)
- X104** – IRIG-B00X, incl. System Contact (Supervision Contact)

MRA4-2D0ACB

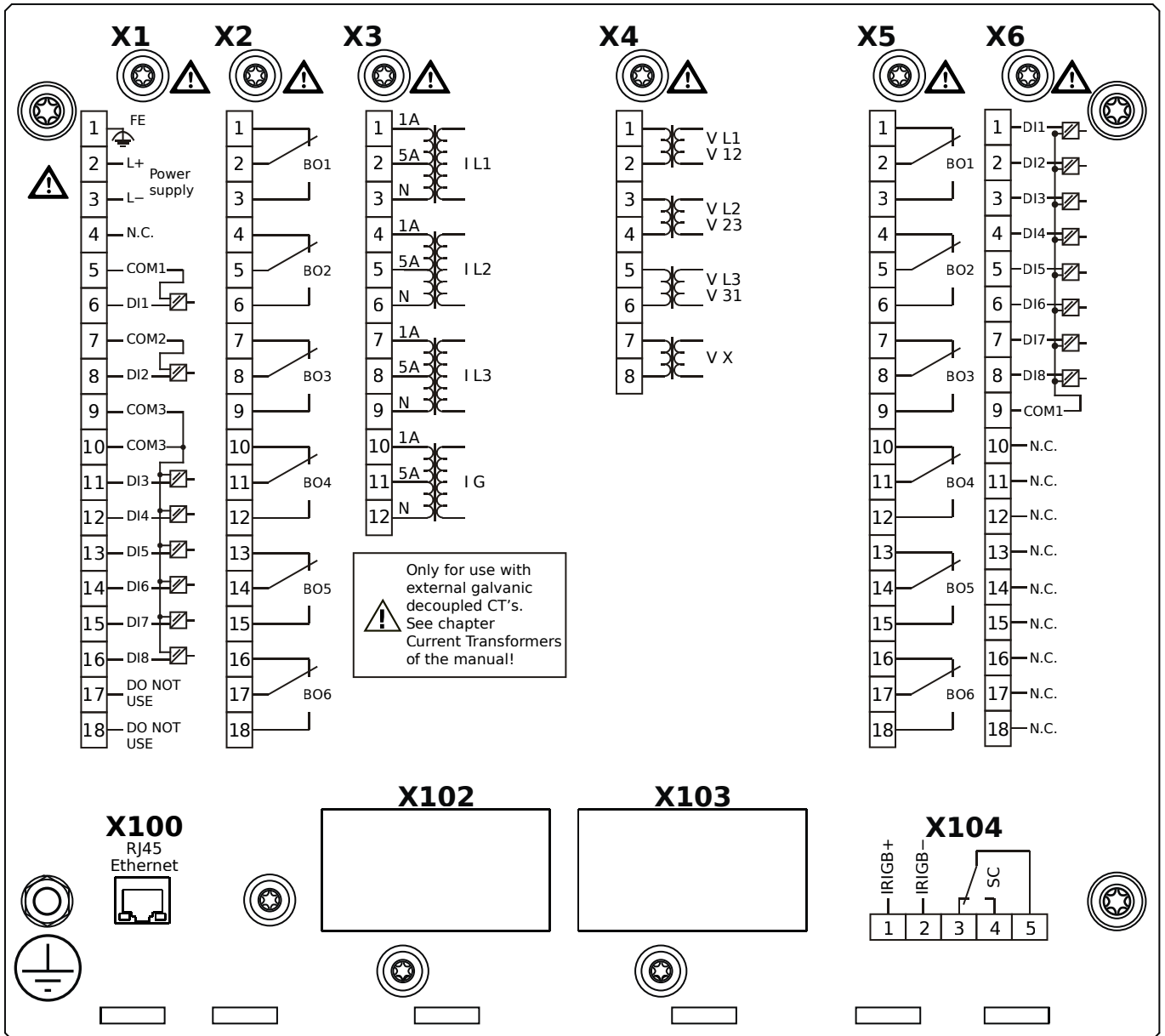

Housing B2, small display, door mounting

+ Conformal Coating (for installations in harsh environment)

- X1** – DI8-X1: Wide-range power supply unit, incl. 2 non-grouped digital inputs and 6 grouped digital inputs
- X2** – OR6: Assembly Group with 6 Output Relays (Changeover / Form C)
- X3** – TI: Standard current measuring card
- X4** – TU: Card with 4 voltage transformer measuring inputs (0 ... 800 VAC, under UL: 0 ... 600 VAC)
- X5** – OR6: Assembly Group with 6 Output Relays (Changeover / Form C)
- X6** – DI8: Assembly Group with 8 Digital Inputs
- X100** – Modbus TCP / DNP3.0 TCP/UDP, Ethernet interface, 100 Mbit/s, RJ45 (BASE100-FX)
- X104** – IRIG-B00X, incl. System Contact (Supervision Contact)

MRA4-2D0ADA

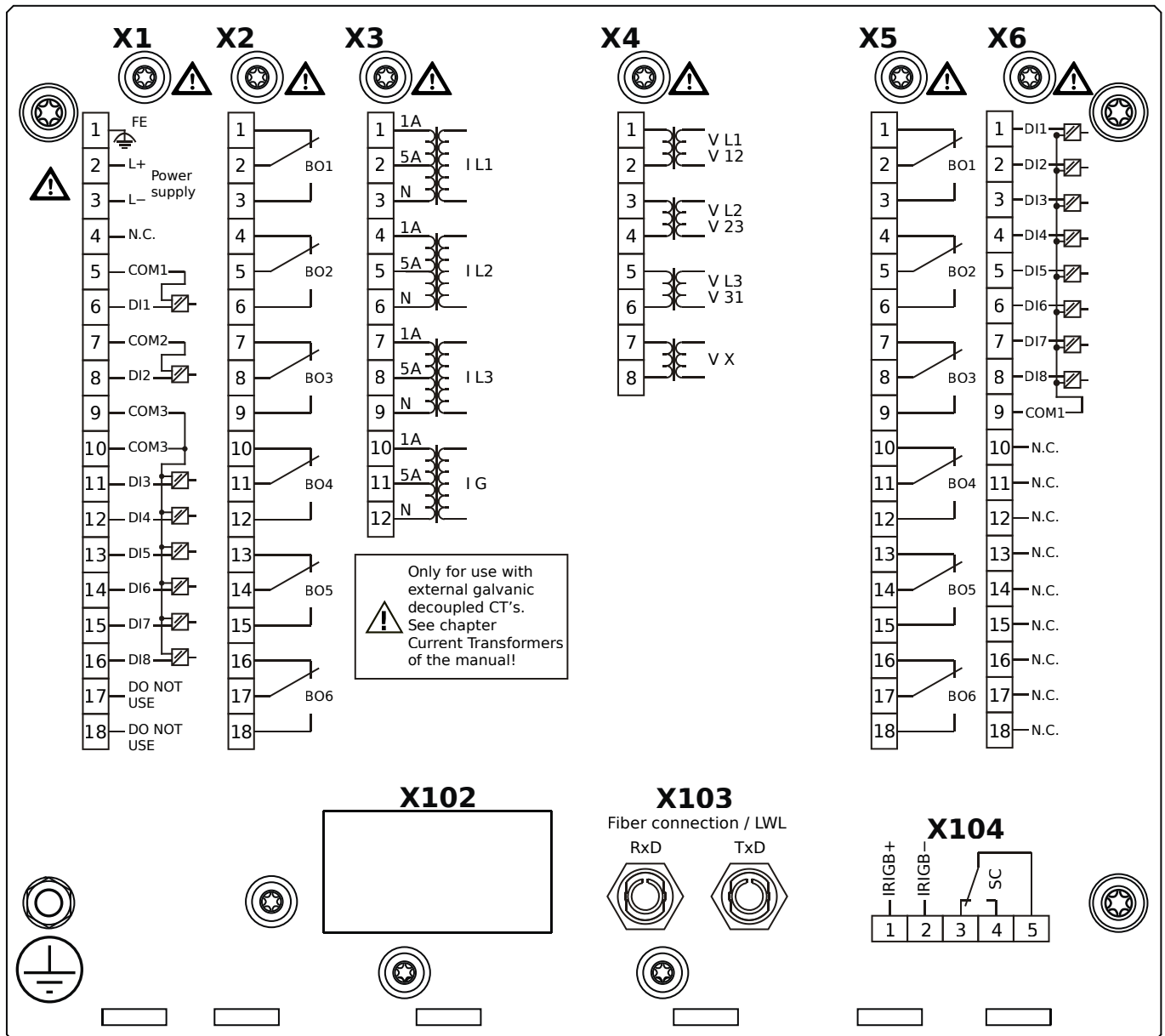

Housing B2, small display, door mounting

- X1** – DI8-X1: Wide-range power supply unit, incl. 2 non-grouped digital inputs and 6 grouped digital inputs
- X2** – OR6: Assembly Group with 6 Output Relays (Changeover / Form C)
- X3** – TI: Standard current measuring card
- X4** – TU: Card with 4 voltage transformer measuring inputs (0 ... 800 VAC, under UL: 0 ... 600 VAC)
- X5** – OR6: Assembly Group with 6 Output Relays (Changeover / Form C)
- X6** – DI8: Assembly Group with 8 Digital Inputs
- X103** – Profibus-DP, Fiber optics interface, ST Connector
- X104** – IRIG-B00X, incl. System Contact (Supervision Contact)

MRA4-2D0ADB

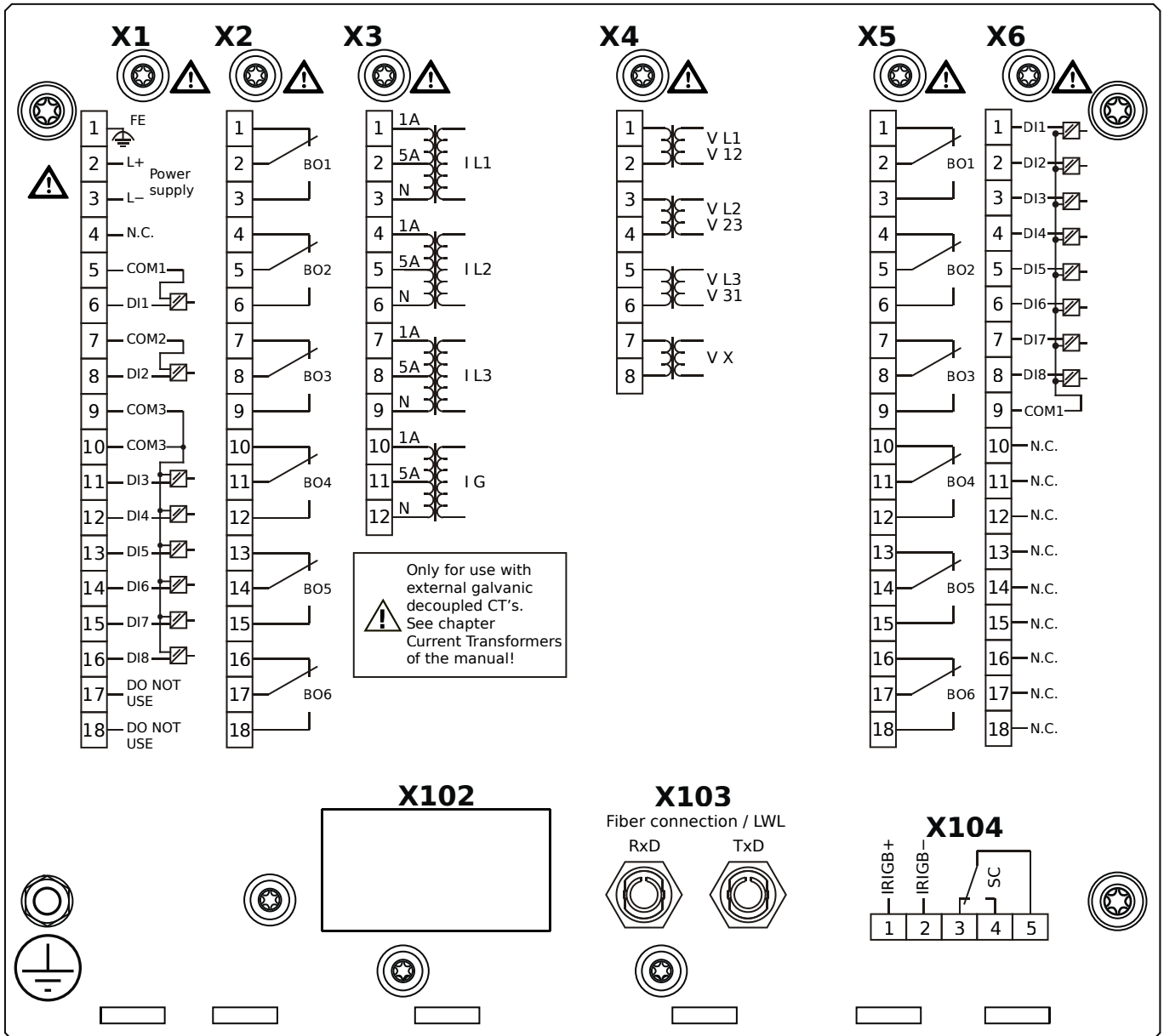

Housing B2, small display, door mounting

- + Conformal Coating (for installations in harsh environment)

- X1** – DI8-X1: Wide-range power supply unit, incl. 2 non-grouped digital inputs and 6 grouped digital inputs
- X2** – OR6: Assembly Group with 6 Output Relays (Changeover / Form C)
- X3** – TI: Standard current measuring card
- X4** – TU: Card with 4 voltage transformer measuring inputs (0 ... 800 VAC, under UL: 0 ... 600 VAC)
- X5** – OR6: Assembly Group with 6 Output Relays (Changeover / Form C)
- X6** – DI8: Assembly Group with 8 Digital Inputs
- X103** – Profibus-DP, Fiber optics interface, ST Connector
- X104** – IRIG-B00X, incl. System Contact (Supervision Contact)

MRA4-2D0AEA

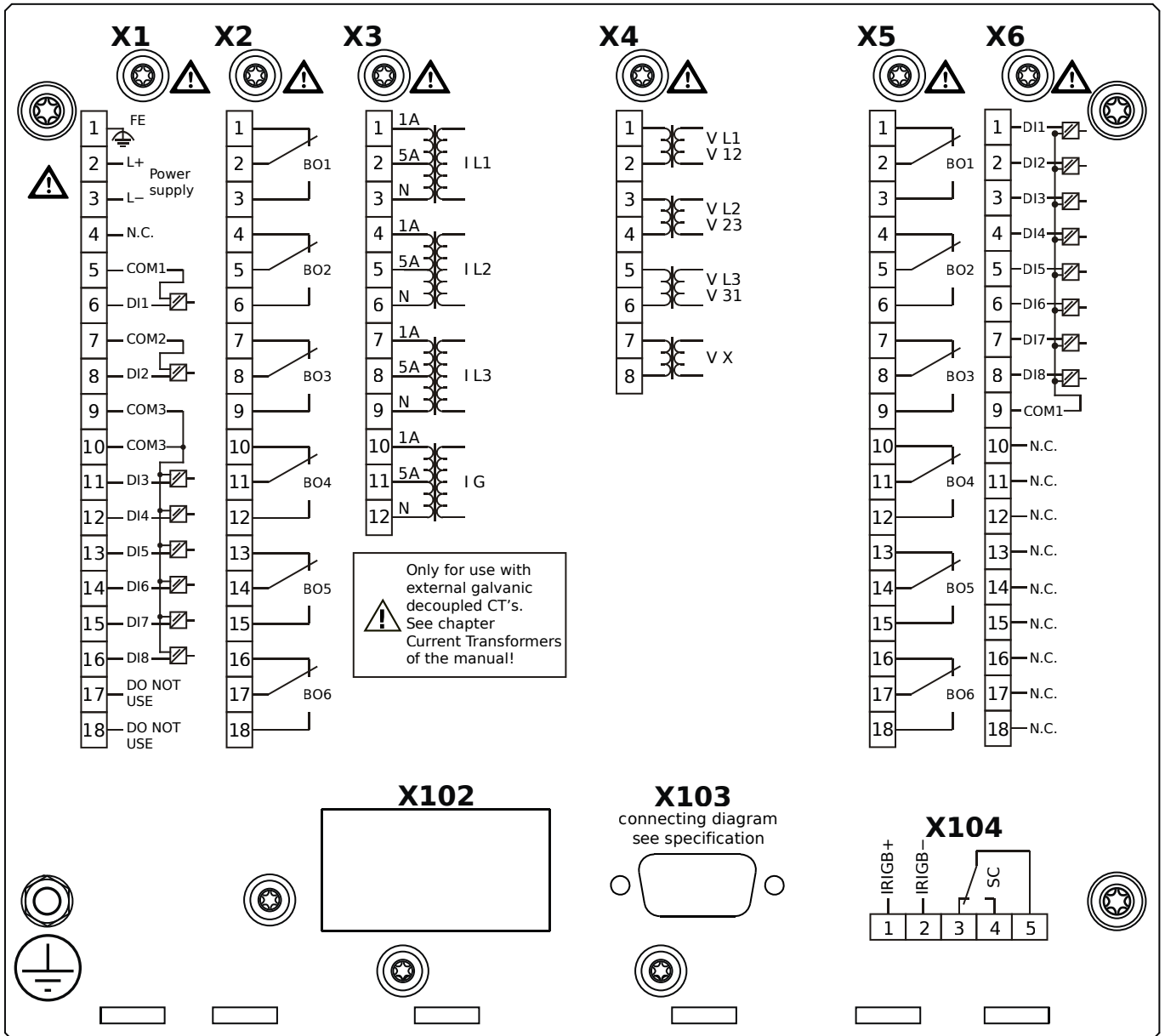

Housing B2, small display, door mounting

- X1** – DI8-X1: Wide-range power supply unit, incl. 2 non-grouped digital inputs and 6 grouped digital inputs
- X2** – OR6: Assembly Group with 6 Output Relays (Changeover / Form C)
- X3** – TI: Standard current measuring card
- X4** – TU: Card with 4 voltage transformer measuring inputs (0 ... 800 VAC, under UL: 0 ... 600 VAC)
- X5** – OR6: Assembly Group with 6 Output Relays (Changeover / Form C)
- X6** – DI8: Assembly Group with 8 Digital Inputs
- X103** – Profibus-DP, RS485, D-SUB
- X104** – IRIG-B00X, incl. System Contact (Supervision Contact)

MRA4-2D0AEB

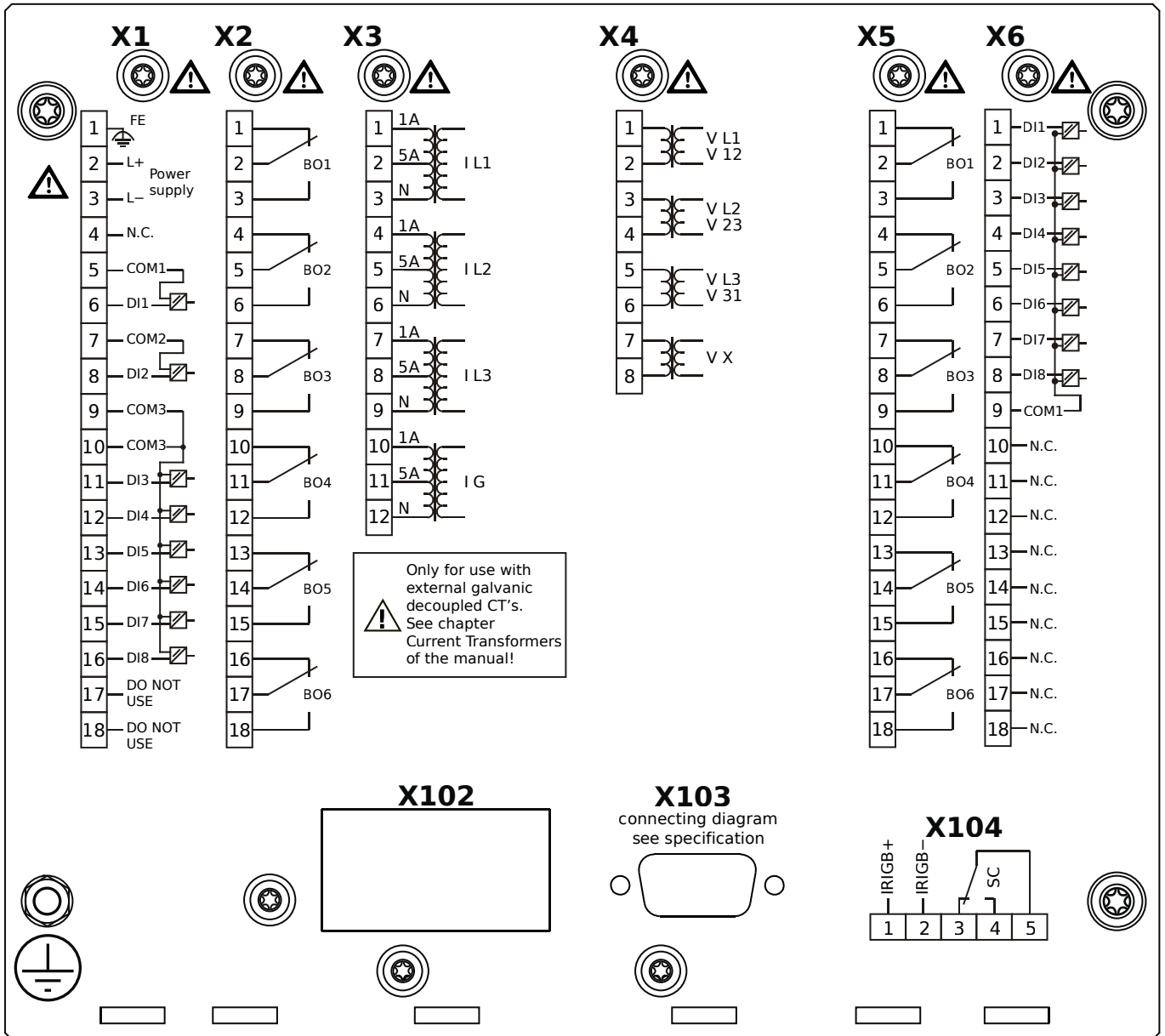

Housing B2, small display, door mounting

+ Conformal Coating (for installations in harsh environment)

- X1** – DI8-X1: Wide-range power supply unit, incl. 2 non-grouped digital inputs and 6 grouped digital inputs
- X2** – OR6: Assembly Group with 6 Output Relays (Changeover / Form C)
- X3** – TI: Standard current measuring card
- X4** – TU: Card with 4 voltage transformer measuring inputs (0 ... 800 VAC, under UL: 0 ... 600 VAC)
- X5** – OR6: Assembly Group with 6 Output Relays (Changeover / Form C)
- X6** – DI8: Assembly Group with 8 Digital Inputs
- X103** – Profibus-DP, RS485, D-SUB
- X104** – IRIG-B00X, incl. System Contact (Supervision Contact)

MRA4-2D0AFA

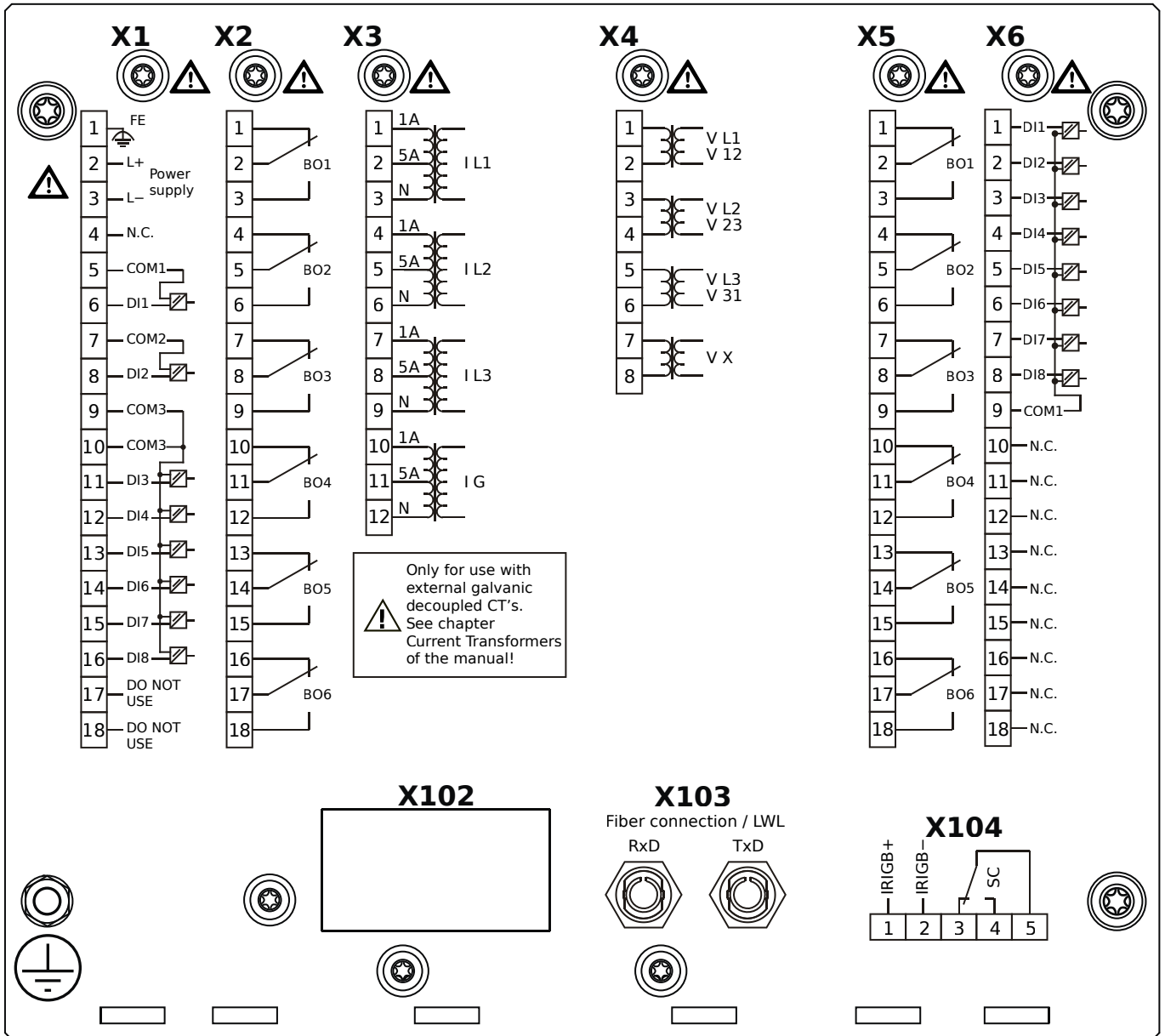

Housing B2, small display, door mounting

- X1** – DI8-X1: Wide-range power supply unit, incl. 2 non-grouped digital inputs and 6 grouped digital inputs
- X2** – OR6: Assembly Group with 6 Output Relays (Changeover / Form C)
- X3** – TI: Standard current measuring card
- X4** – TU: Card with 4 voltage transformer measuring inputs (0 ... 800 VAC, under UL: 0 ... 600 VAC)
- X5** – OR6: Assembly Group with 6 Output Relays (Changeover / Form C)
- X6** – DI8: Assembly Group with 8 Digital Inputs
- X103** – Modbus RTU / IEC 60870-5-103 / DNP3.0 RTU, Fiber optics interface, ST Connector
- X104** – IRIG-B00X, incl. System Contact (Supervision Contact)

MRA4-2D0AFB

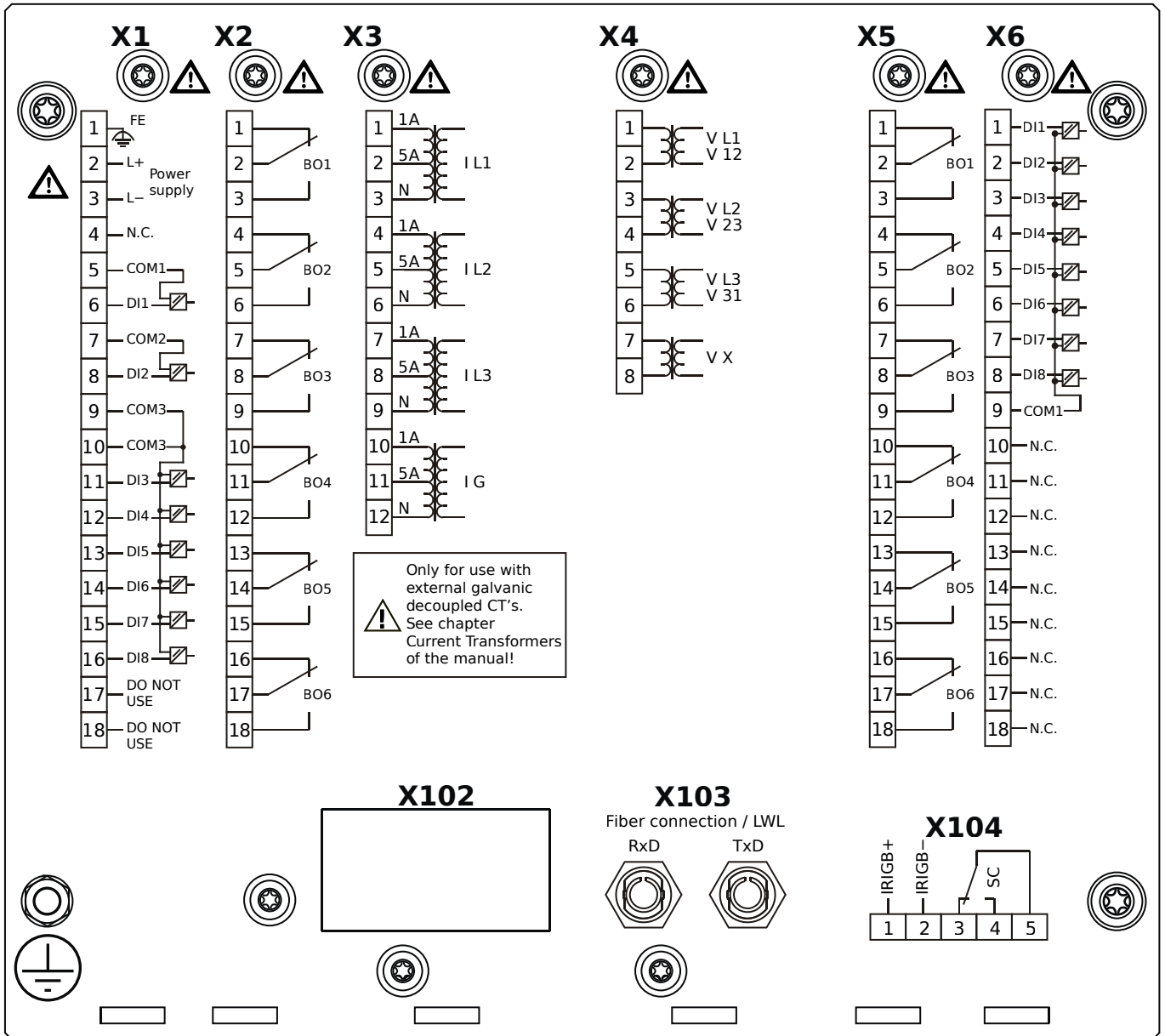

Housing B2, small display, door mounting

+ Conformal Coating (for installations in harsh environment)

- X1** – DI8-X1: Wide-range power supply unit, incl. 2 non-grouped digital inputs and 6 grouped digital inputs
- X2** – OR6: Assembly Group with 6 Output Relays (Changeover / Form C)
- X3** – TI: Standard current measuring card
- X4** – TU: Card with 4 voltage transformer measuring inputs (0 ... 800 VAC, under UL: 0 ... 600 VAC)
- X5** – OR6: Assembly Group with 6 Output Relays (Changeover / Form C)
- X6** – DI8: Assembly Group with 8 Digital Inputs
- X103** – Modbus RTU / IEC 60870-5-103 / DNP3.0 RTU, Fiber optics interface, ST Connector
- X104** – IRIG-B00X, incl. System Contact (Supervision Contact)

MRA4-2D0AGA

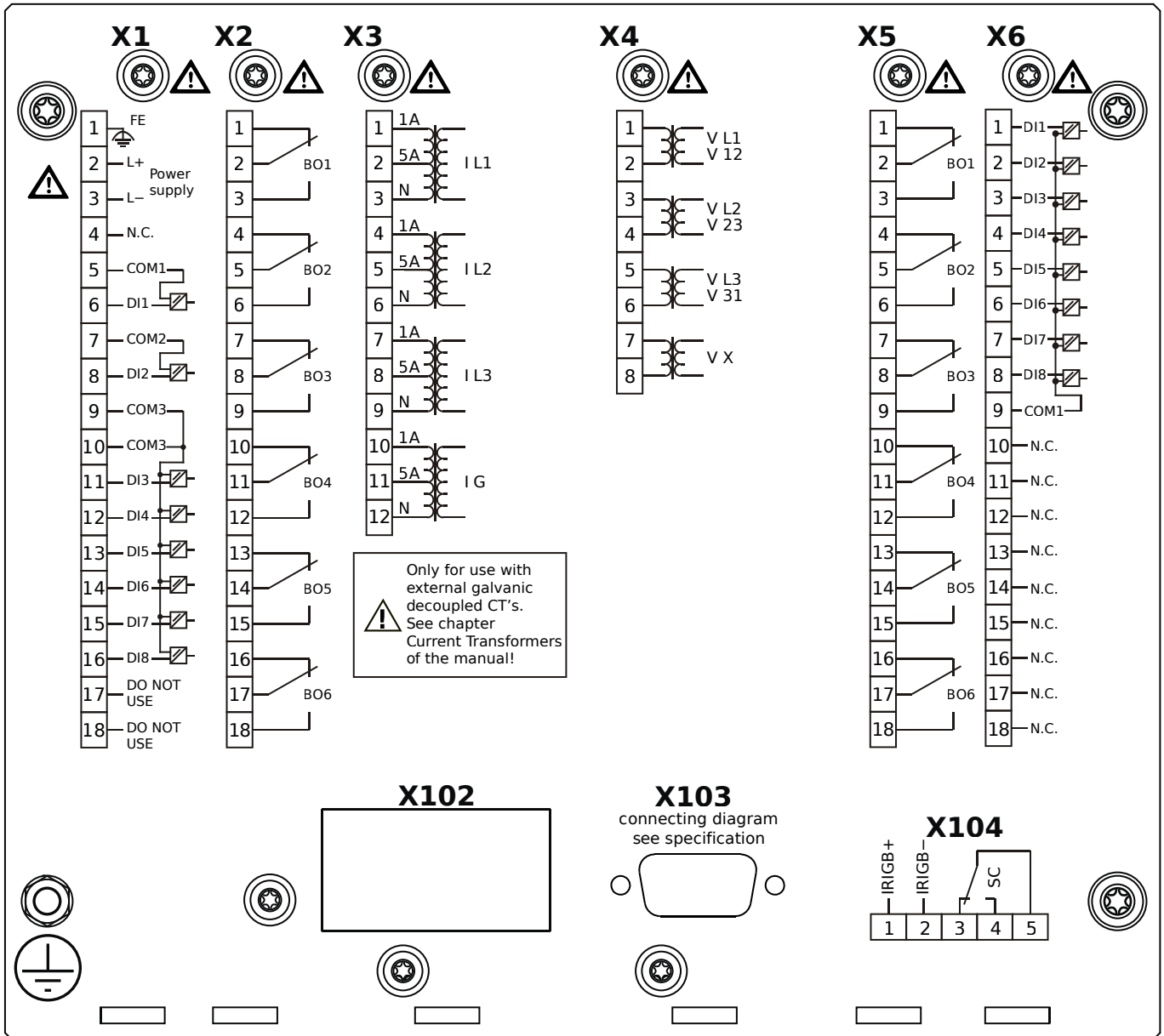

Housing B2, small display, door mounting

- X1** – DI8-X1: Wide-range power supply unit, incl. 2 non-grouped digital inputs and 6 grouped digital inputs
- X2** – OR6: Assembly Group with 6 Output Relays (Changeover / Form C)
- X3** – TI: Standard current measuring card
- X4** – TU: Card with 4 voltage transformer measuring inputs (0 ... 800 VAC, under UL: 0 ... 600 VAC)
- X5** – OR6: Assembly Group with 6 Output Relays (Changeover / Form C)
- X6** – DI8: Assembly Group with 8 Digital Inputs
- X103** – Modbus RTU / IEC 60870-5-103 / DNP3.0 RTU, RS485, D-SUB
- X104** – IRIG-B00X, incl. System Contact (Supervision Contact)

MRA4-2D0AGB

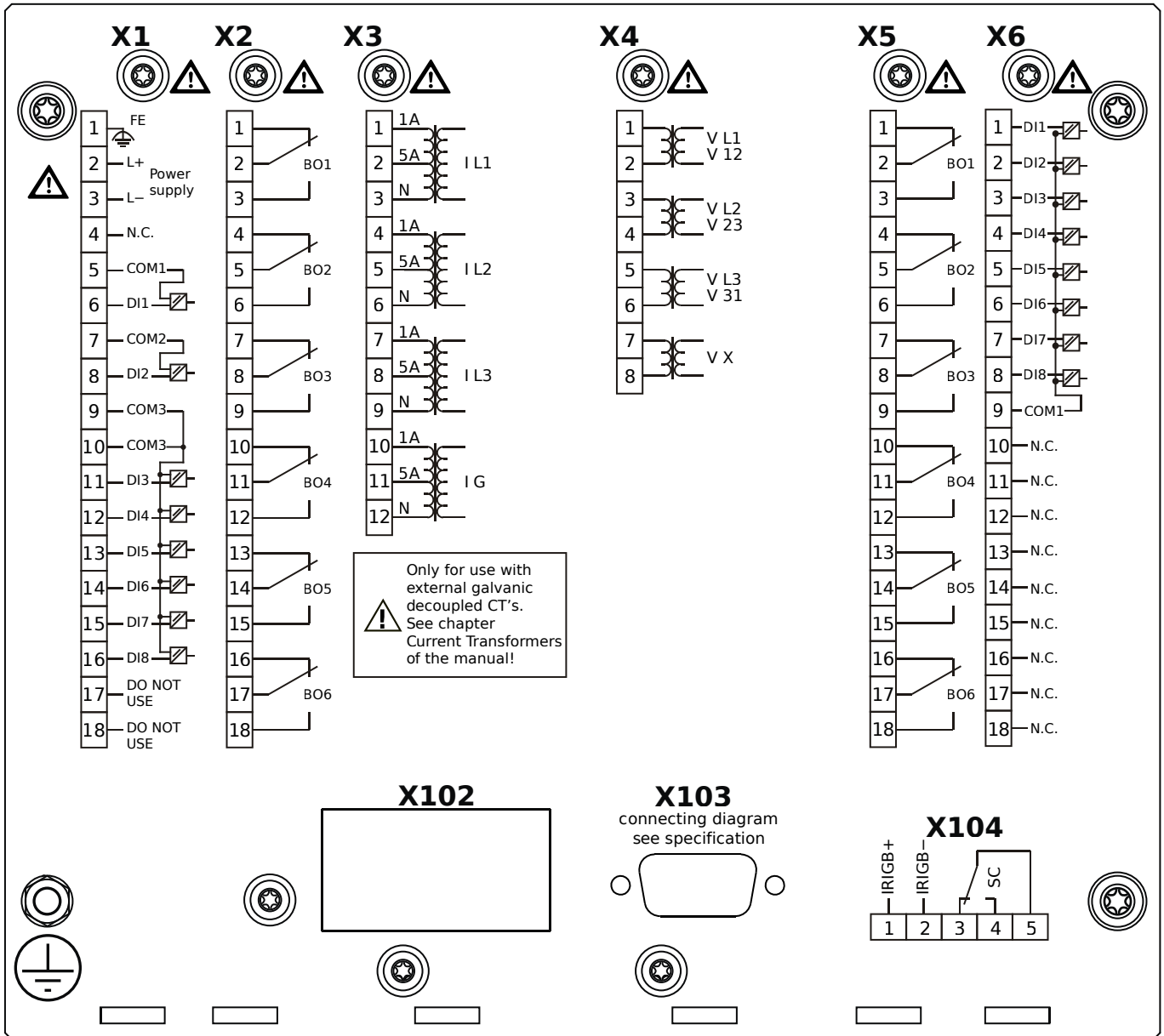

Housing B2, small display, door mounting

+ Conformal Coating (for installations in harsh environment)

- X1** – DI8-X1: Wide-range power supply unit, incl. 2 non-grouped digital inputs and 6 grouped digital inputs
- X2** – OR6: Assembly Group with 6 Output Relays (Changeover / Form C)
- X3** – TI: Standard current measuring card
- X4** – TU: Card with 4 voltage transformer measuring inputs (0 ... 800 VAC, under UL: 0 ... 600 VAC)
- X5** – OR6: Assembly Group with 6 Output Relays (Changeover / Form C)
- X6** – DI8: Assembly Group with 8 Digital Inputs
- X103** – Modbus RTU / IEC 60870-5-103 / DNP3.0 RTU, RS485, D-SUB
- X104** – IRIG-B00X, incl. System Contact (Supervision Contact)

MRA4-2D0AHA

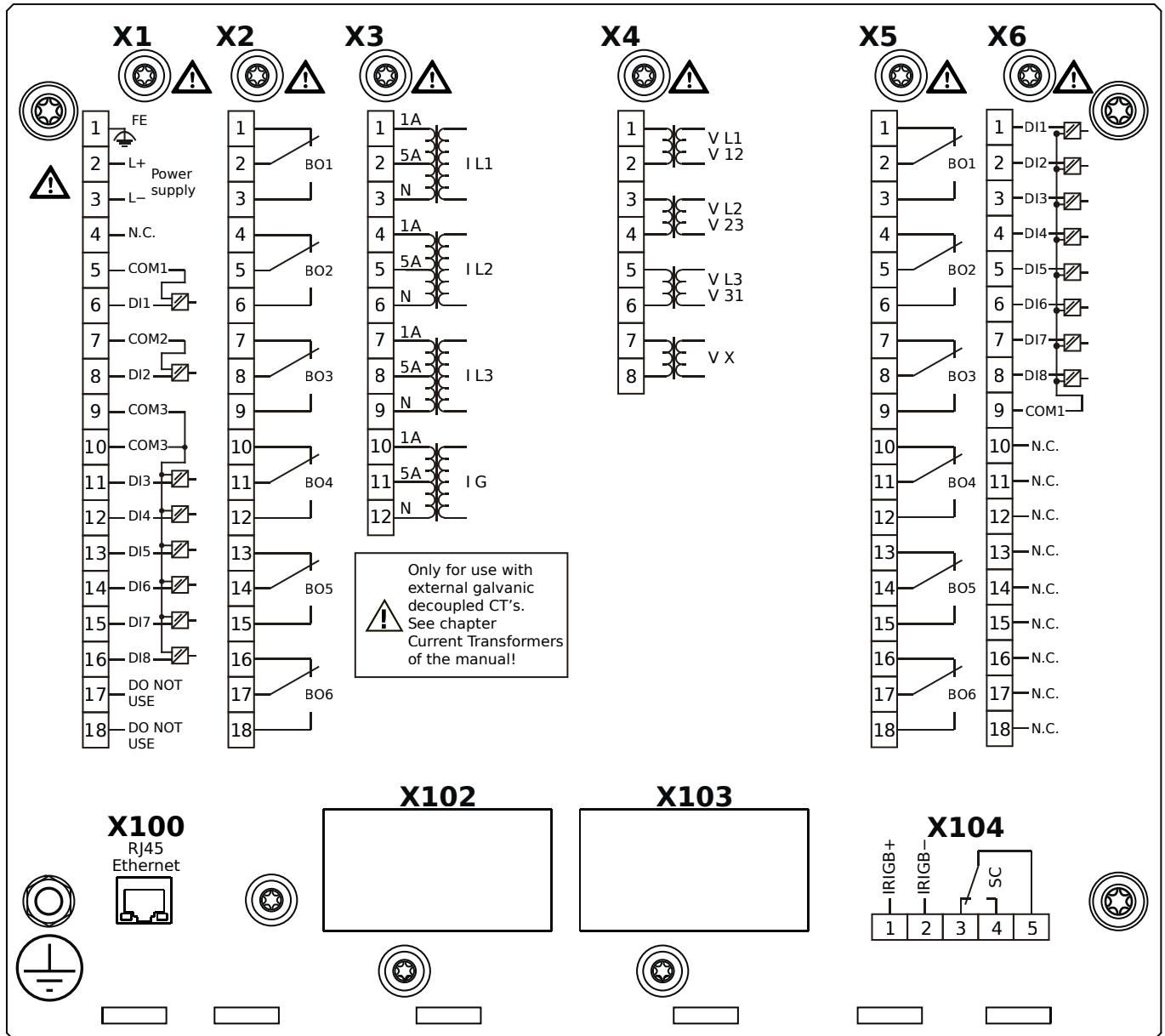

Housing B2, small display, door mounting

- X1** – DI8-X1: Wide-range power supply unit, incl. 2 non-grouped digital inputs and 6 grouped digital inputs
- X2** – OR6: Assembly Group with 6 Output Relays (Changeover / Form C)
- X3** – TI: Standard current measuring card
- X4** – TU: Card with 4 voltage transformer measuring inputs (0 ... 800 VAC, under UL: 0 ... 600 VAC)
- X5** – OR6: Assembly Group with 6 Output Relays (Changeover / Form C)
- X6** – DI8: Assembly Group with 8 Digital Inputs
- X100** – IEC 61850 / Modbus TCP / DNP3.0 TCP/UDP, Ethernet interface, 100 Mbit/s, RJ45 (BASE100-FX)
- X104** – IRIG-B00X, incl. System Contact (Supervision Contact)

MRA4-2D0AHB

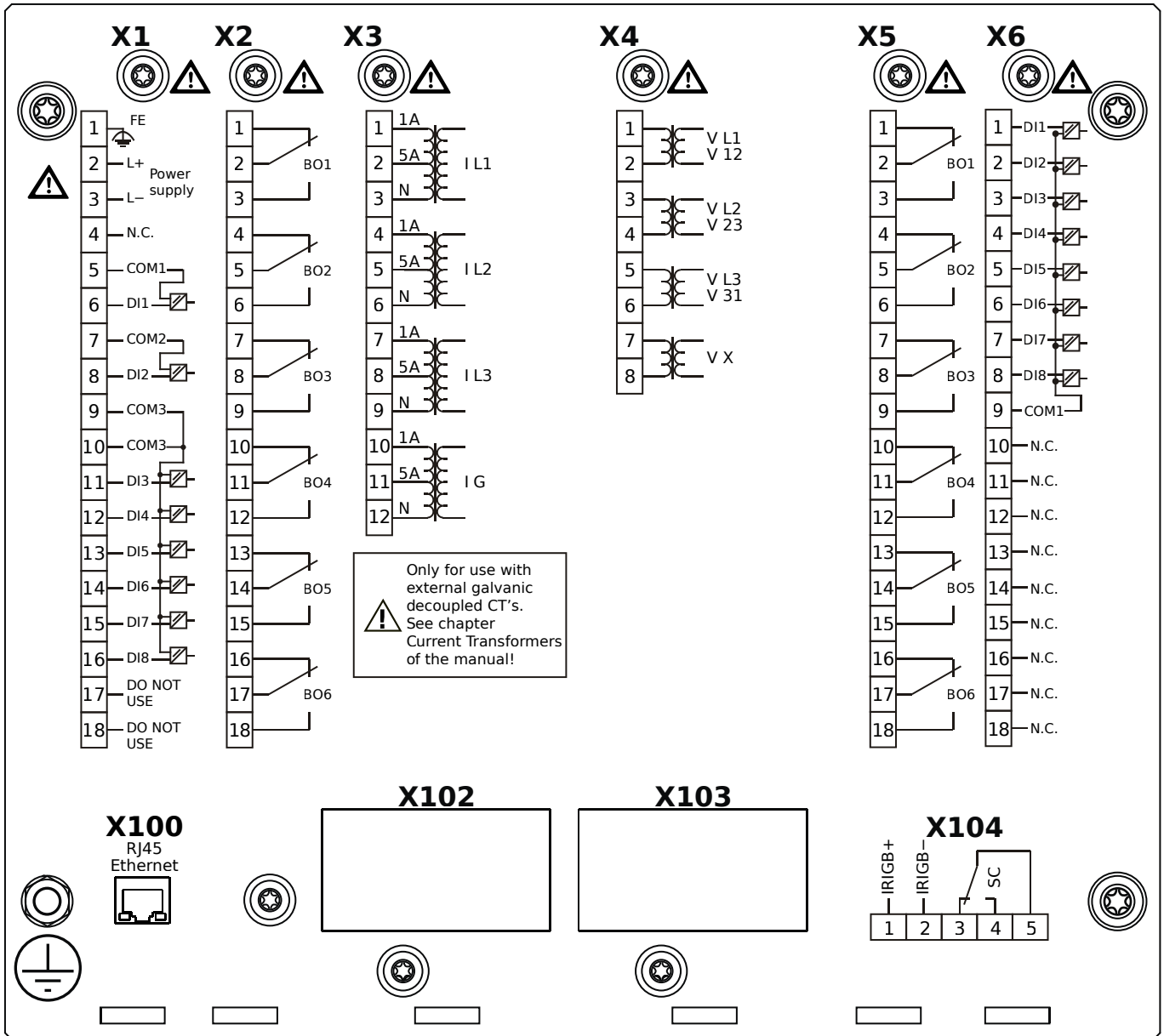

Housing B2, small display, door mounting

+ Conformal Coating (for installations in harsh environment)

- X1** – DI8-X1: Wide-range power supply unit, incl. 2 non-grouped digital inputs and 6 grouped digital inputs
- X2** – OR6: Assembly Group with 6 Output Relays (Changeover / Form C)
- X3** – TI: Standard current measuring card
- X4** – TU: Card with 4 voltage transformer measuring inputs (0 ... 800 VAC, under UL: 0 ... 600 VAC)
- X5** – OR6: Assembly Group with 6 Output Relays (Changeover / Form C)
- X6** – DI8: Assembly Group with 8 Digital Inputs
- X100** – IEC 61850 / Modbus TCP / DNP3.0 TCP/UDP, Ethernet interface, 100 Mbit/s, RJ45 (BASE100-FX)
- X104** – IRIG-B00X, incl. System Contact (Supervision Contact)

MRA4-2D0AIA

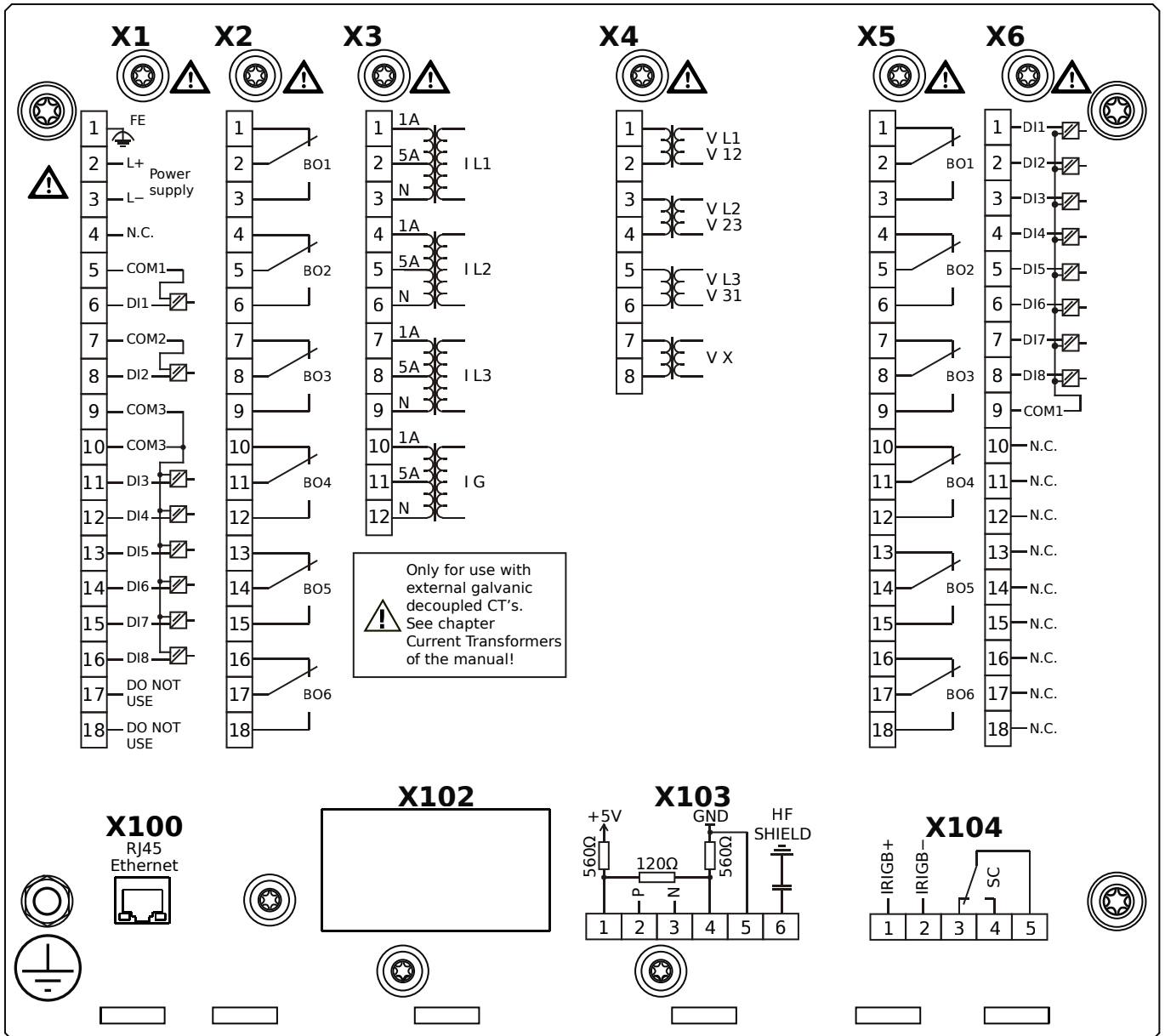

Housing B2, small display, door mounting

- X1** – DI8-X1: Wide-range power supply unit, incl. 2 non-grouped digital inputs and 6 grouped digital inputs
- X2** – OR6: Assembly Group with 6 Output Relays (Changeover / Form C)
- X3** – TI: Standard current measuring card
- X4** – TU: Card with 4 voltage transformer measuring inputs (0 ... 800 VAC, under UL: 0 ... 600 VAC)
- X5** – OR6: Assembly Group with 6 Output Relays (Changeover / Form C)
- X6** – DI8: Assembly Group with 8 Digital Inputs
- X100** – Modbus TCP / DNP3.0 TCP/UDP, Ethernet interface, 100 Mbit/s, RJ45 (BASE100-FX)
- X103** – IEC 60870-5-103 / Modbus RTU / DNP3.0 RTU, RS485, Terminals
- X104** – IRIG-B00X, incl. System Contact (Supervision Contact)

MRA4-2D0AIB

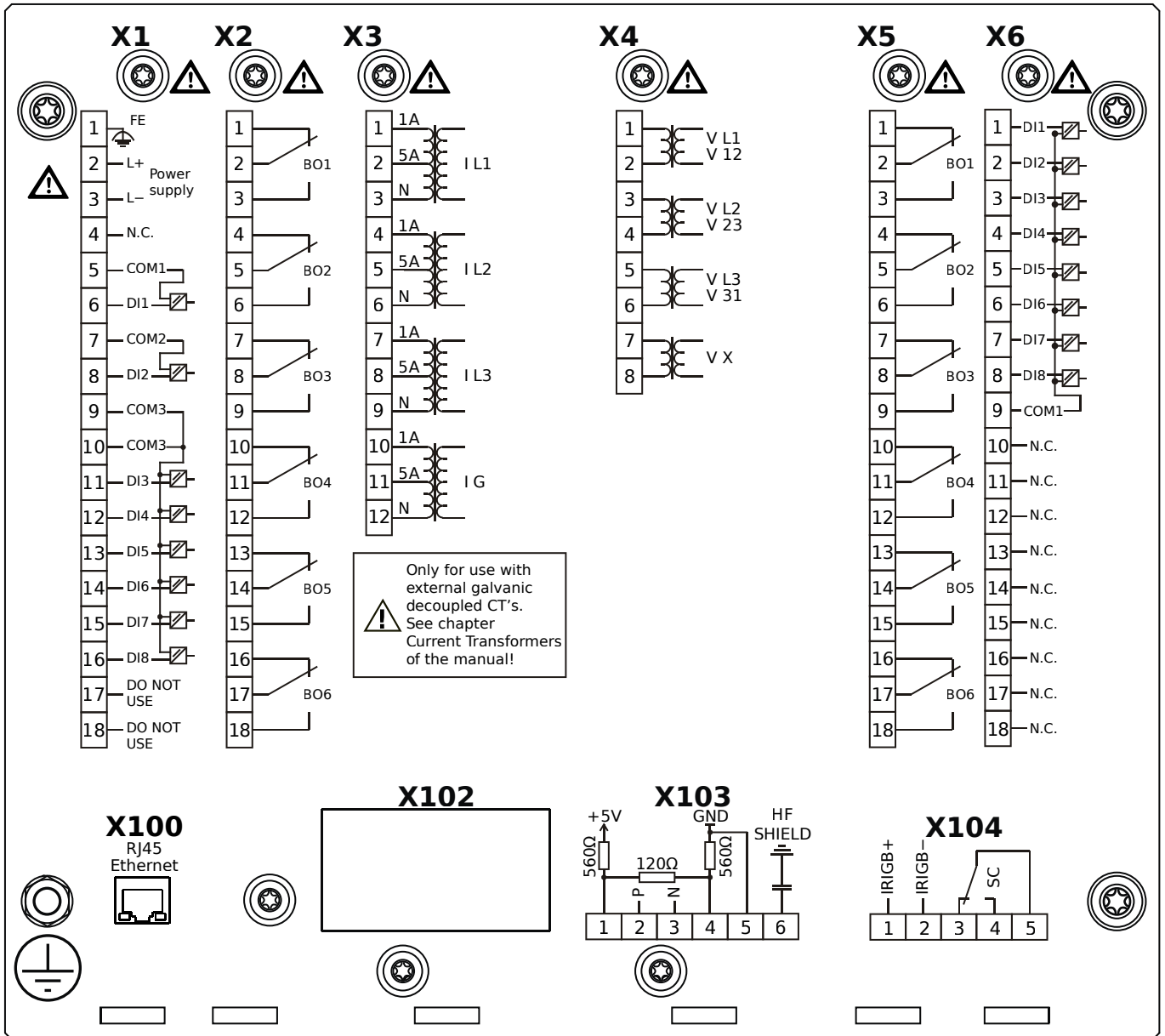

Housing B2, small display, door mounting

+ Conformal Coating (for installations in harsh environment)

- X1** – DI8-X1: Wide-range power supply unit, incl. 2 non-grouped digital inputs and 6 grouped digital inputs
- X2** – OR6: Assembly Group with 6 Output Relays (Changeover / Form C)
- X3** – TI: Standard current measuring card
- X4** – TU: Card with 4 voltage transformer measuring inputs (0 ... 800 VAC, under UL: 0 ... 600 VAC)
- X5** – OR6: Assembly Group with 6 Output Relays (Changeover / Form C)
- X6** – DI8: Assembly Group with 8 Digital Inputs
- X100** – Modbus TCP / DNP3.0 TCP/UDP, Ethernet interface, 100 Mbit/s, RJ45 (BASE100-FX)
- X103** – IEC 60870-5-103 / Modbus RTU / DNP3.0 RTU, RS485, Terminals
- X104** – IRIG-B00X, incl. System Contact (Supervision Contact)

MRA4-2D0AKA

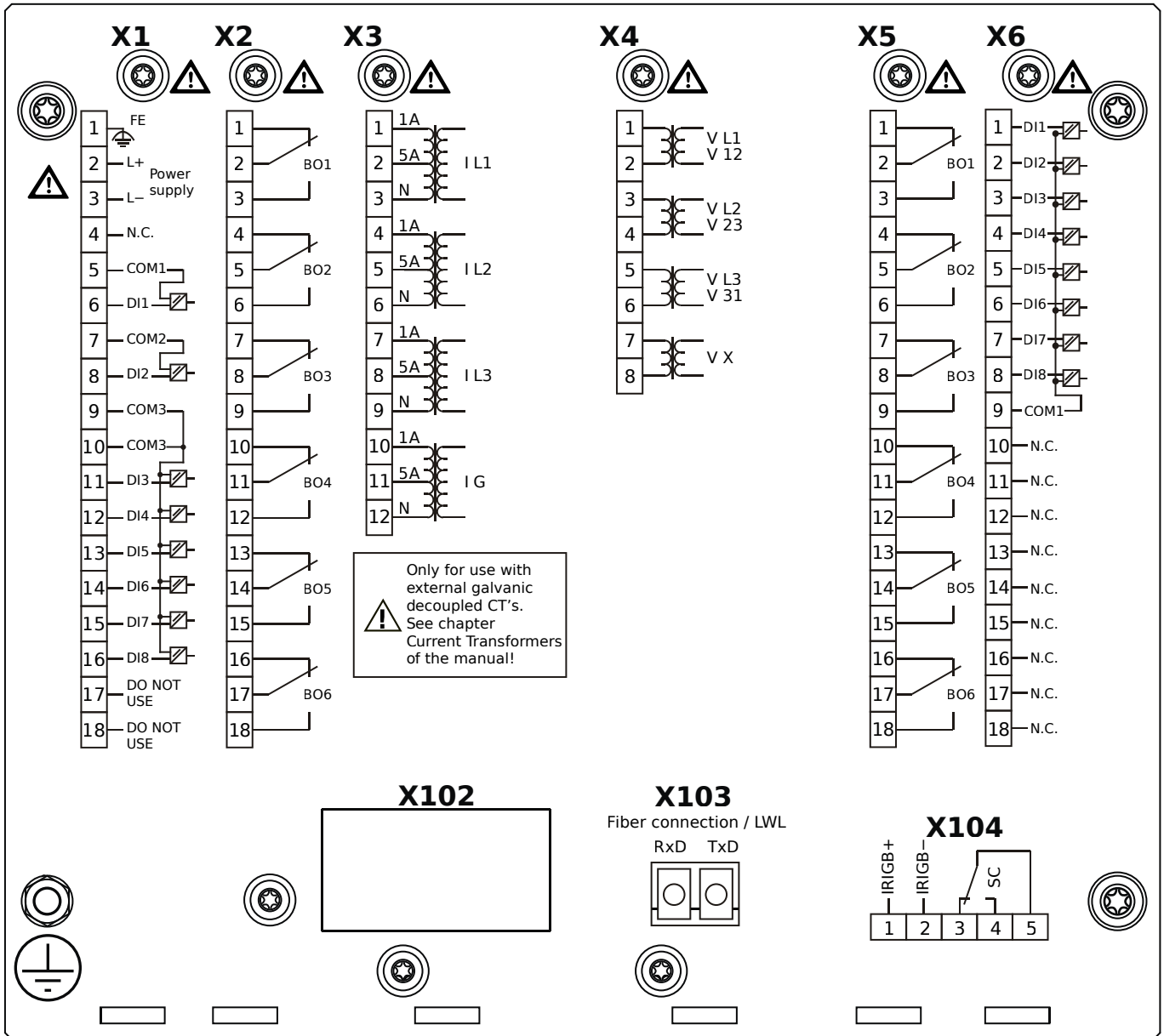

Housing B2, small display, door mounting

- X1** – DI8-X1: Wide-range power supply unit, incl. 2 non-grouped digital inputs and 6 grouped digital inputs
- X2** – OR6: Assembly Group with 6 Output Relays (Changeover / Form C)
- X3** – TI: Standard current measuring card
- X4** – TU: Card with 4 voltage transformer measuring inputs (0 ... 800 VAC, under UL: 0 ... 600 VAC)
- X5** – OR6: Assembly Group with 6 Output Relays (Changeover / Form C)
- X6** – DI8: Assembly Group with 8 Digital Inputs
- X103** – IEC 61850 / Modbus TCP / DNP3.0 TCP/UDP, Fiber optics interface, LC Connector
- X104** – IRIG-B00X, incl. System Contact (Supervision Contact)

MRA4-2D0AKB

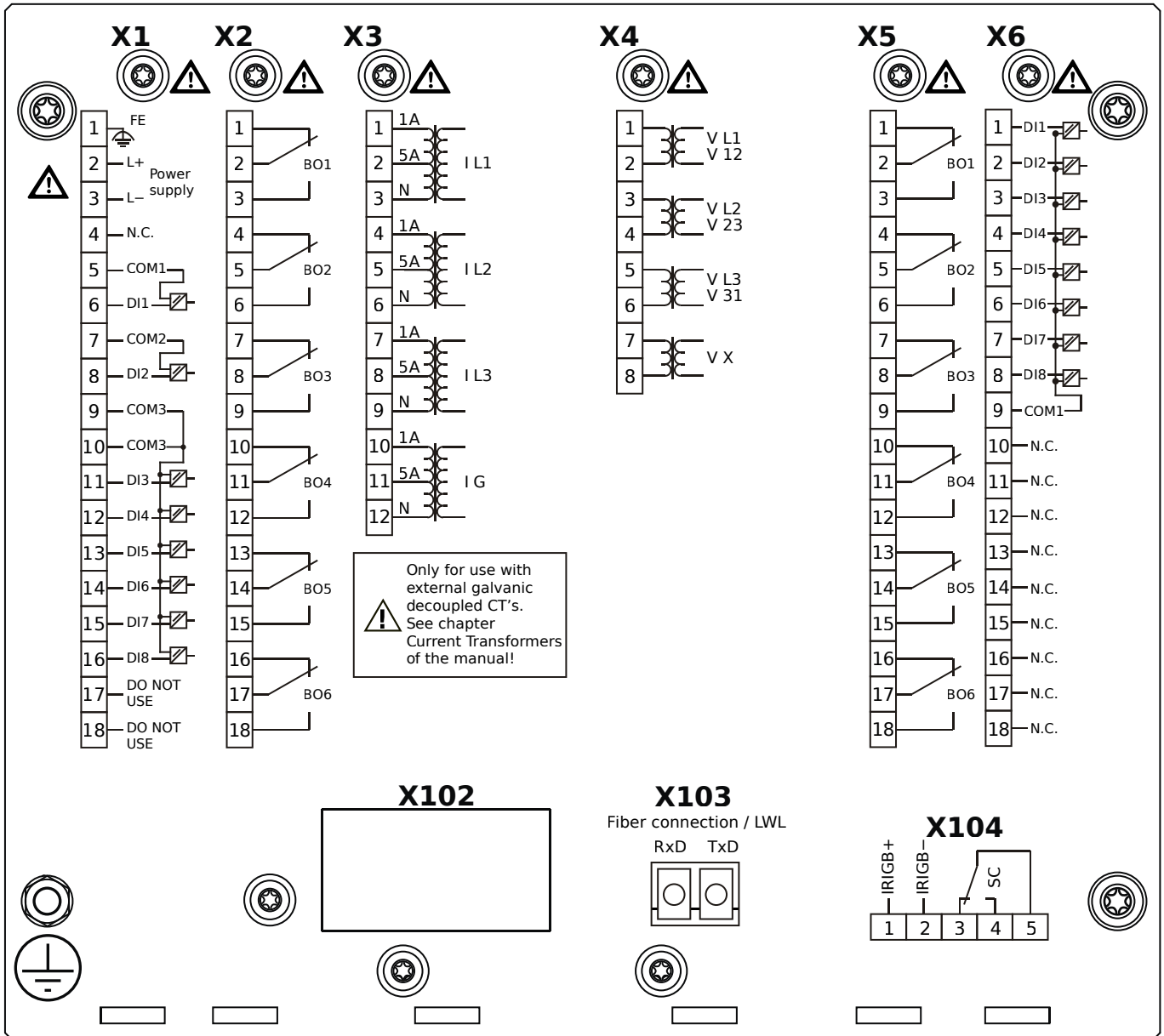

Housing B2, small display, door mounting

+ Conformal Coating (for installations in harsh environment)

- X1** – DI8-X1: Wide-range power supply unit, incl. 2 non-grouped digital inputs and 6 grouped digital inputs
- X2** – OR6: Assembly Group with 6 Output Relays (Changeover / Form C)
- X3** – TI: Standard current measuring card
- X4** – TU: Card with 4 voltage transformer measuring inputs (0 ... 800 VAC, under UL: 0 ... 600 VAC)
- X5** – OR6: Assembly Group with 6 Output Relays (Changeover / Form C)
- X6** – DI8: Assembly Group with 8 Digital Inputs
- X103** – IEC 61850 / Modbus TCP / DNP3.0 TCP/UDP, Fiber optics interface, LC Connector
- X104** – IRIG-B00X, incl. System Contact (Supervision Contact)

MRA4-2D0ALA

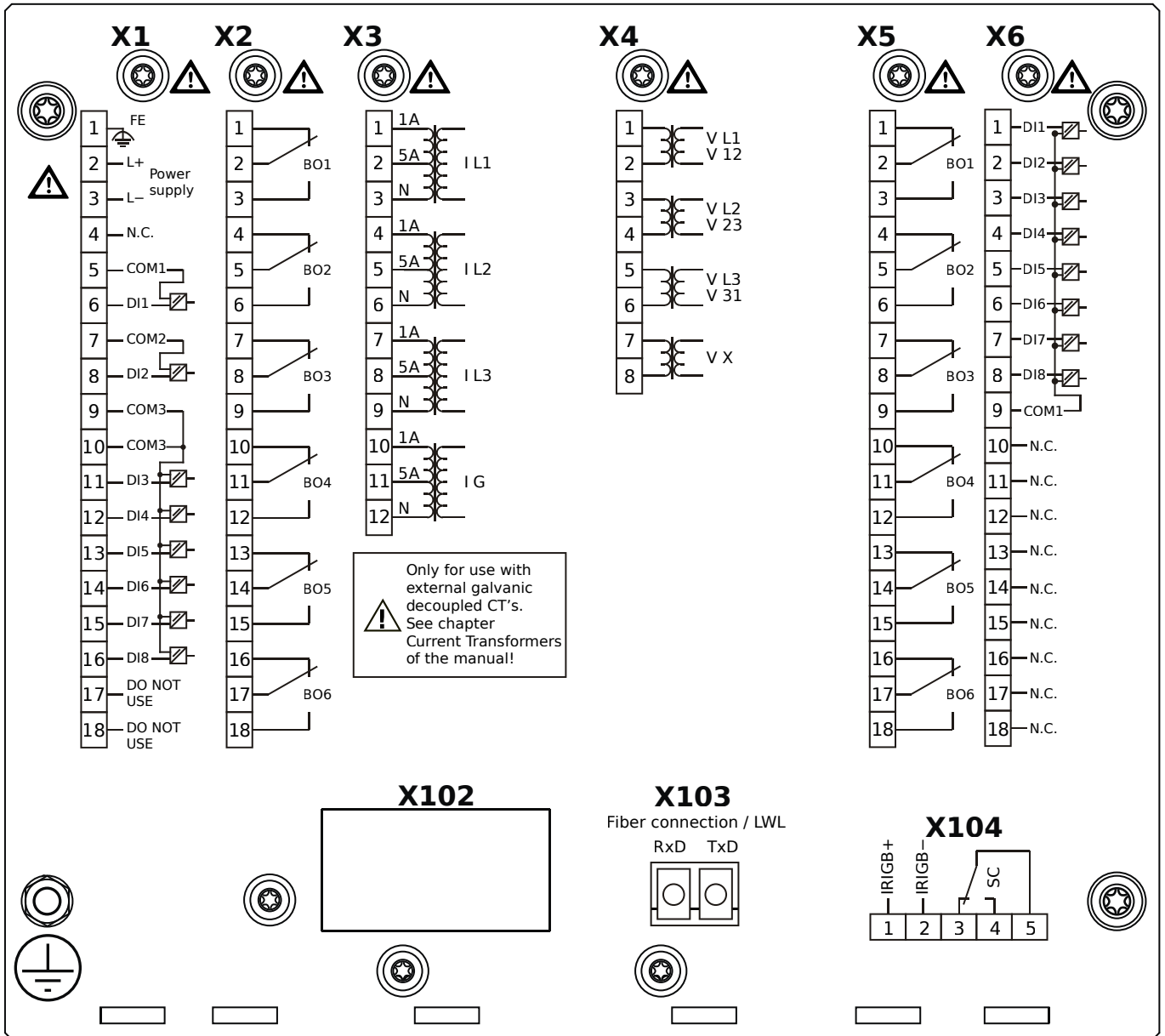

Housing B2, small display, door mounting

- X1** – DI8-X1: Wide-range power supply unit, incl. 2 non-grouped digital inputs and 6 grouped digital inputs
- X2** – OR6: Assembly Group with 6 Output Relays (Changeover / Form C)
- X3** – TI: Standard current measuring card
- X4** – TU: Card with 4 voltage transformer measuring inputs (0 ... 800 VAC, under UL: 0 ... 600 VAC)
- X5** – OR6: Assembly Group with 6 Output Relays (Changeover / Form C)
- X6** – DI8: Assembly Group with 8 Digital Inputs
- X103** – Modbus TCP / DNP3.0 TCP/UDP, Fiber optics interface, LC Connector
- X104** – IRIG-B00X, incl. System Contact (Supervision Contact)

MRA4-2D0ALB

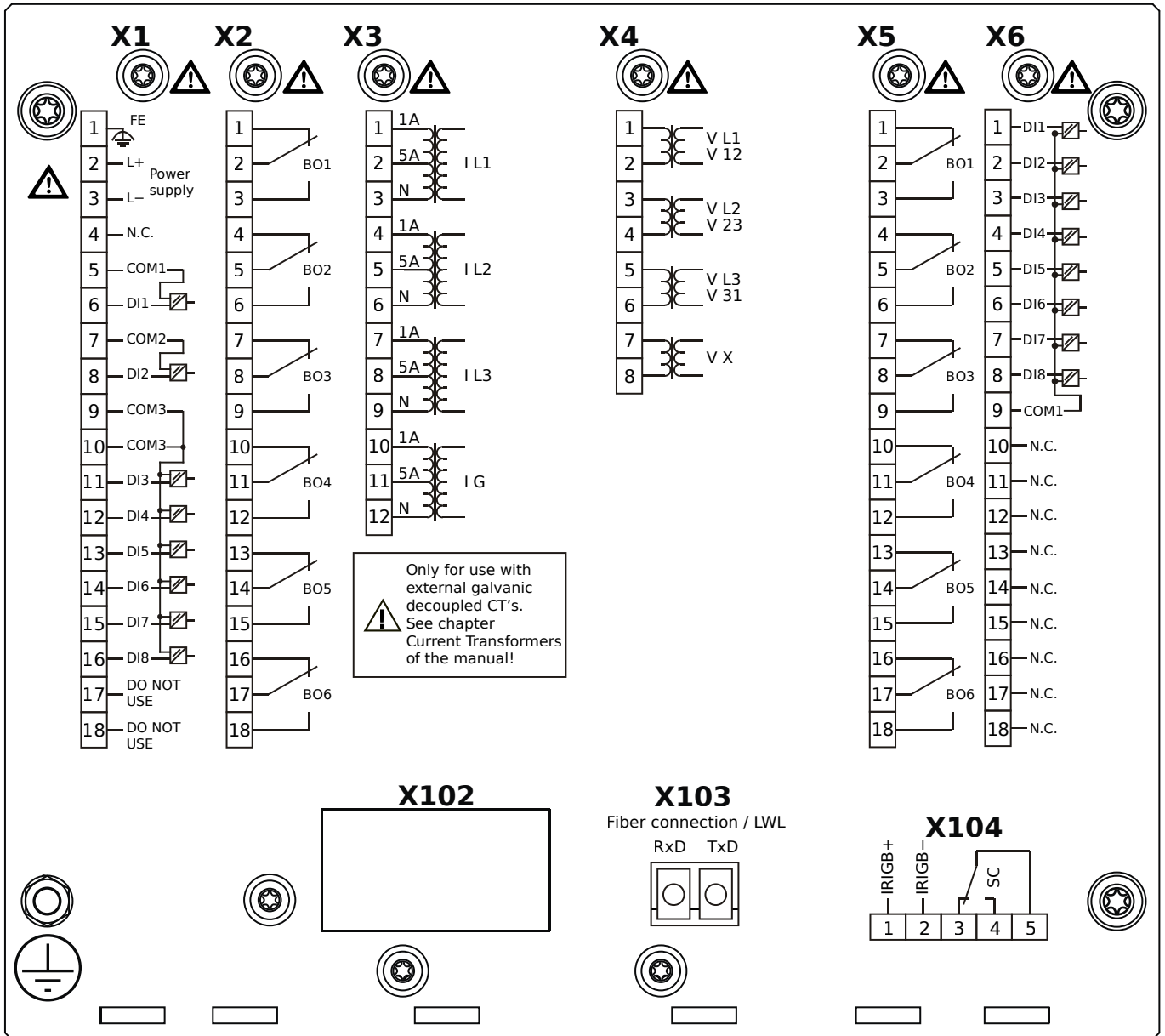

Housing B2, small display, door mounting

+ Conformal Coating (for installations in harsh environment)

- X1** – DI8-X1: Wide-range power supply unit, incl. 2 non-grouped digital inputs and 6 grouped digital inputs
- X2** – OR6: Assembly Group with 6 Output Relays (Changeover / Form C)
- X3** – TI: Standard current measuring card
- X4** – TU: Card with 4 voltage transformer measuring inputs (0 ... 800 VAC, under UL: 0 ... 600 VAC)
- X5** – OR6: Assembly Group with 6 Output Relays (Changeover / Form C)
- X6** – DI8: Assembly Group with 8 Digital Inputs
- X103** – Modbus TCP / DNP3.0 TCP/UDP, Fiber optics interface, LC Connector
- X104** – IRIG-B00X, incl. System Contact (Supervision Contact)

MRA4-2D0ATA

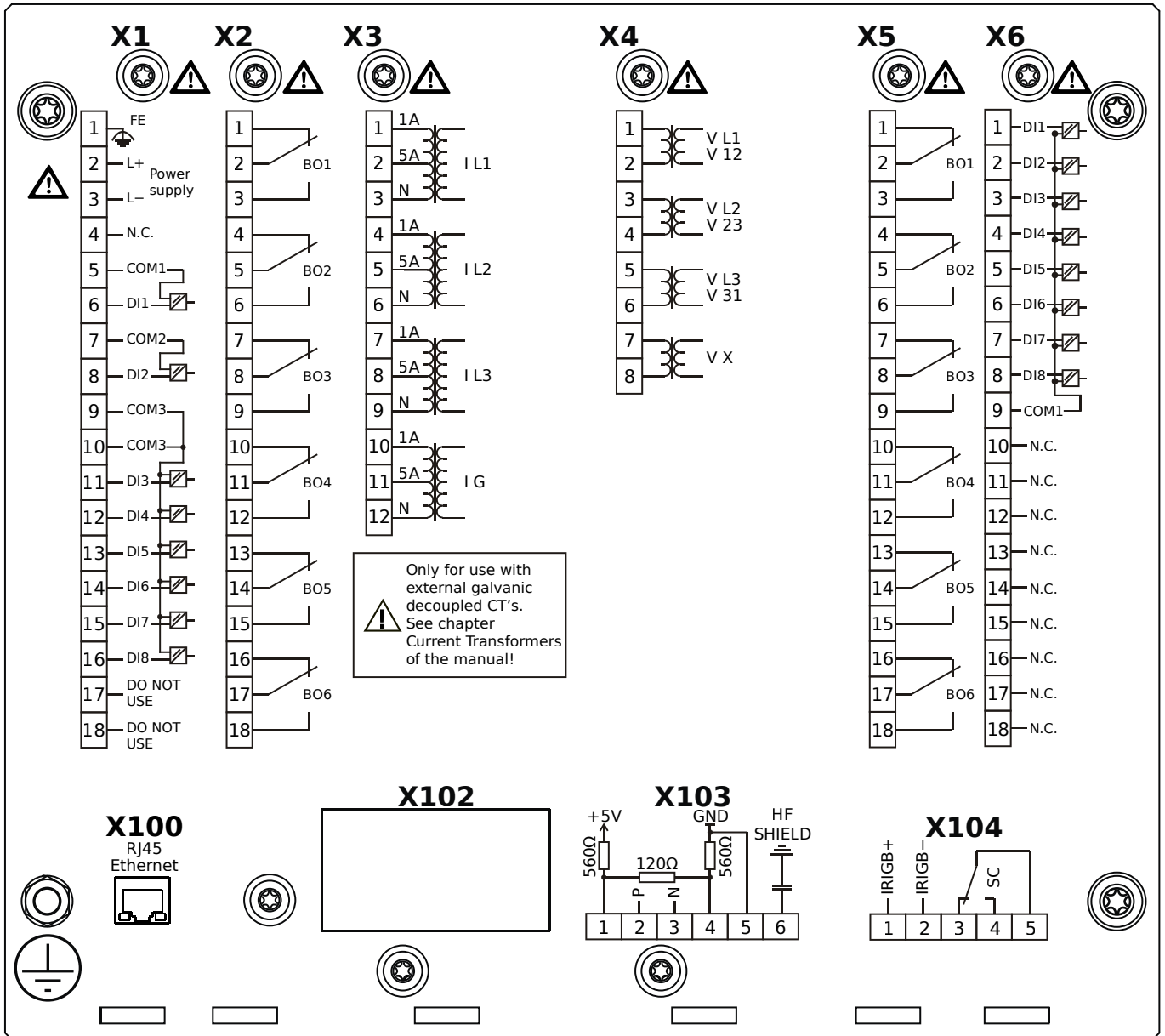

Housing B2, small display, door mounting

- X1** – DI8-X1: Wide-range power supply unit, incl. 2 non-grouped digital inputs and 6 grouped digital inputs
- X2** – OR6: Assembly Group with 6 Output Relays (Changeover / Form C)
- X3** – TI: Standard current measuring card
- X4** – TU: Card with 4 voltage transformer measuring inputs (0 ... 800 VAC, under UL: 0 ... 600 VAC)
- X5** – OR6: Assembly Group with 6 Output Relays (Changeover / Form C)
- X6** – DI8: Assembly Group with 8 Digital Inputs
- X100** – IEC 61850 / Modbus TCP / DNP3.0 TCP/UDP, Ethernet interface, 100 Mbit/s, RJ45 (BASE100-FX)
- X103** – IEC 60870-5-103 / Modbus RTU / DNP3.0 RTU, RS485, Terminals
- X104** – IRIG-B00X, incl. System Contact (Supervision Contact)

MRA4-2D0ATB

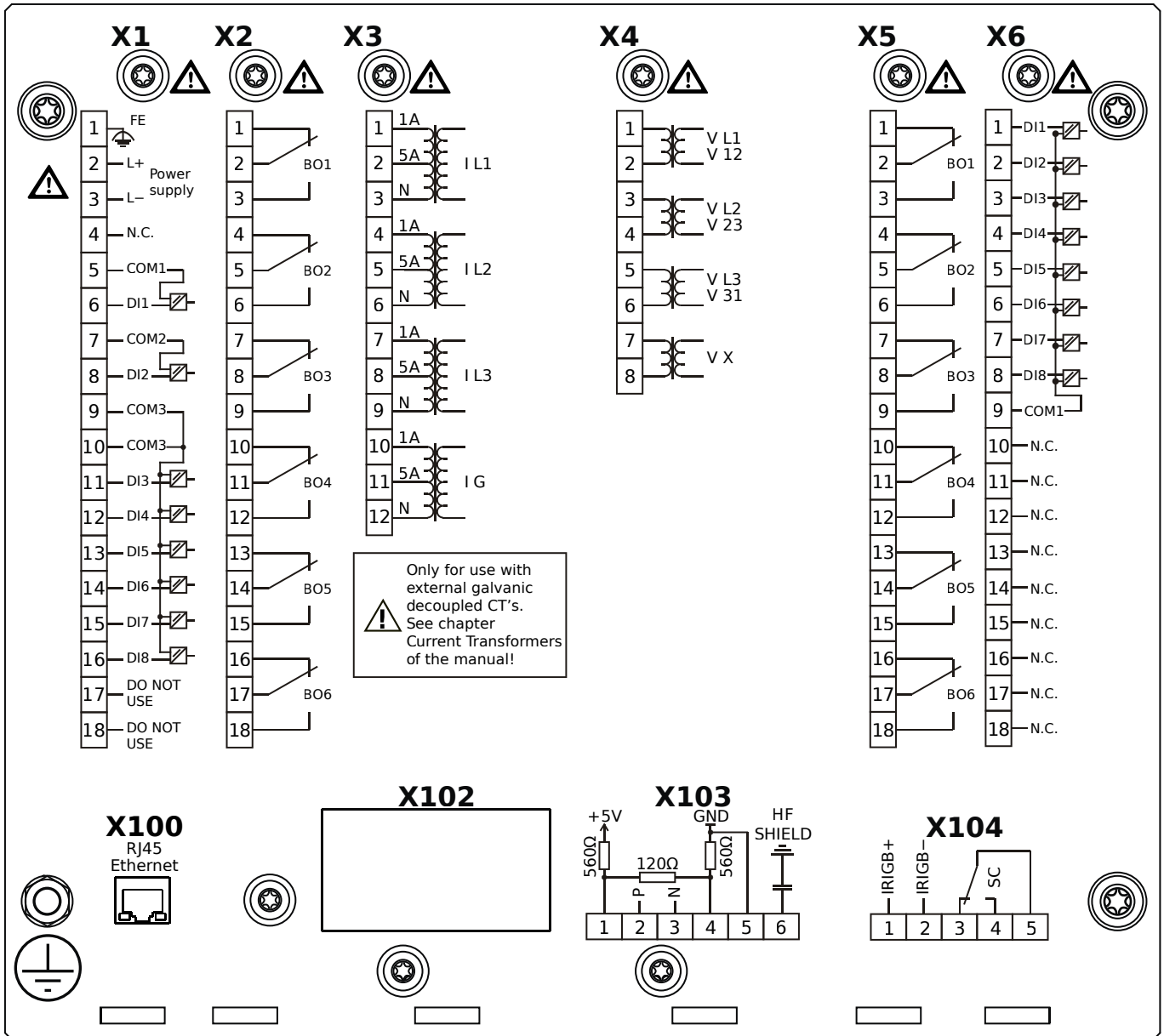

Housing B2, small display, door mounting

+ Conformal Coating (for installations in harsh environment)

- X1** – DI8-X1: Wide-range power supply unit, incl. 2 non-grouped digital inputs and 6 grouped digital inputs
- X2** – OR6: Assembly Group with 6 Output Relays (Changeover / Form C)
- X3** – TI: Standard current measuring card
- X4** – TU: Card with 4 voltage transformer measuring inputs (0 ... 800 VAC, under UL: 0 ... 600 VAC)
- X5** – OR6: Assembly Group with 6 Output Relays (Changeover / Form C)
- X6** – DI8: Assembly Group with 8 Digital Inputs
- X100** – IEC 61850 / Modbus TCP / DNP3.0 TCP/UDP, Ethernet interface, 100 Mbit/s, RJ45 (BASE100-FX)
- X103** – IEC 60870-5-103 / Modbus RTU / DNP3.0 RTU, RS485, Terminals
- X104** – IRIG-B00X, incl. System Contact (Supervision Contact)

MRA4-2D0BAA

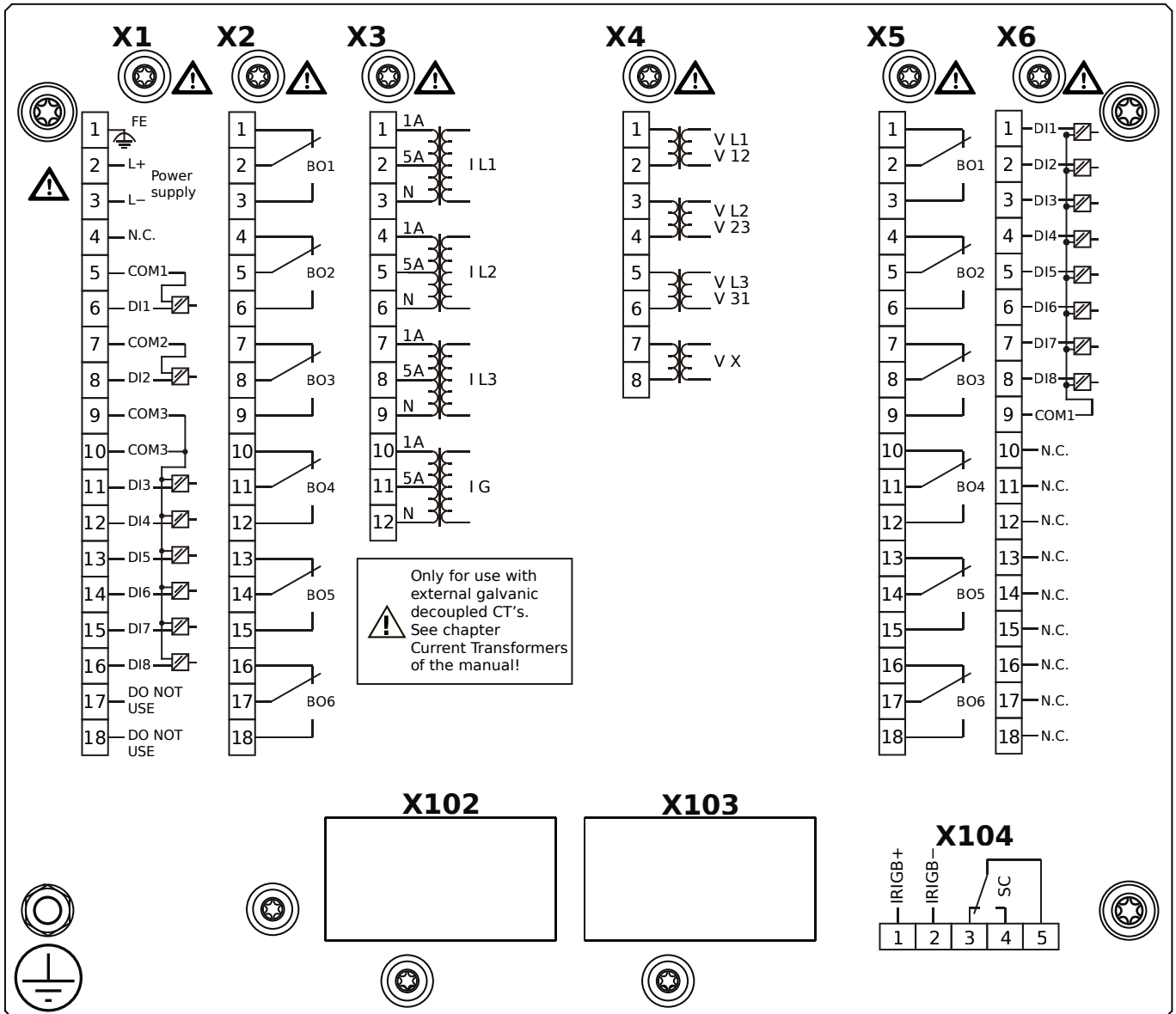

Housing B2, small display, 19" rack mounting

- X1** – DI8-X1: Wide-range power supply unit, incl. 2 non-grouped digital inputs and 6 grouped digital inputs
- X2** – OR6: Assembly Group with 6 Output Relays (Changeover / Form C)
- X3** – TI: Standard current measuring card
- X4** – TU: Card with 4 voltage transformer measuring inputs (0 ... 800 VAC, under UL: 0 ... 600 VAC)
- X5** – OR6: Assembly Group with 6 Output Relays (Changeover / Form C)
- X6** – DI8: Assembly Group with 8 Digital Inputs
- X104** – IRIG-B00X, incl. System Contact (Supervision Contact)

MRA4-2D0BAB

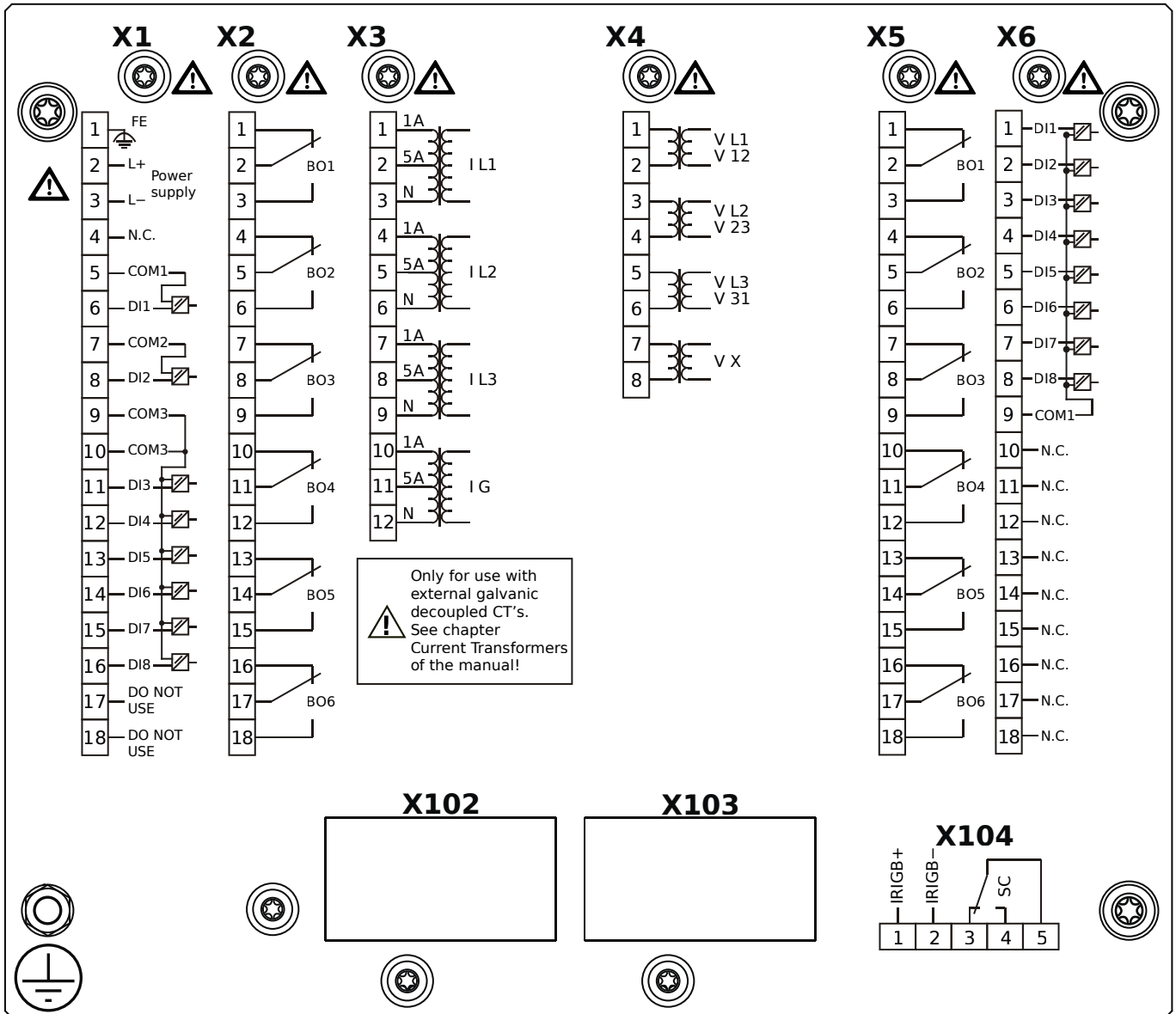

Housing B2, small display, 19" rack mounting

+ Conformal Coating (for installations in harsh environment)

- X1** – DI8-X1: Wide-range power supply unit, incl. 2 non-grouped digital inputs and 6 grouped digital inputs
- X2** – OR6: Assembly Group with 6 Output Relays (Changeover / Form C)
- X3** – TI: Standard current measuring card
- X4** – TU: Card with 4 voltage transformer measuring inputs (0 ... 800 VAC, under UL: 0 ... 600 VAC)
- X5** – OR6: Assembly Group with 6 Output Relays (Changeover / Form C)
- X6** – DI8: Assembly Group with 8 Digital Inputs
- X104** – IRIG-B00X, incl. System Contact (Supervision Contact)

MRA4-2D0BBA

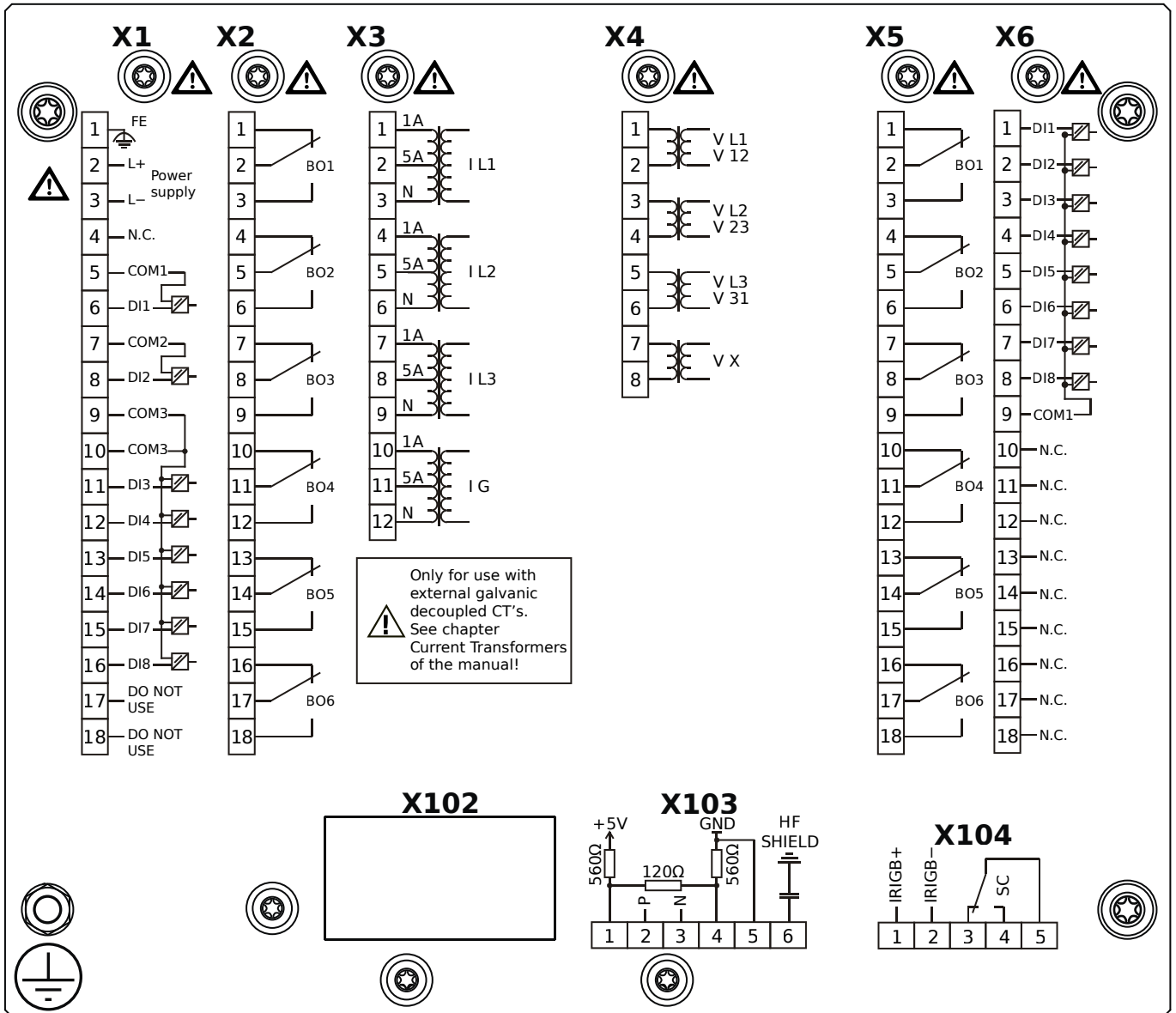

Housing B2, small display, 19" rack mounting

- X1** – DI8-X1: Wide-range power supply unit, incl. 2 non-grouped digital inputs and 6 grouped digital inputs
- X2** – OR6: Assembly Group with 6 Output Relays (Changeover / Form C)
- X3** – TI: Standard current measuring card
- X4** – TU: Card with 4 voltage transformer measuring inputs (0 ... 800 VAC, under UL: 0 ... 600 VAC)
- X5** – OR6: Assembly Group with 6 Output Relays (Changeover / Form C)
- X6** – DI8: Assembly Group with 8 Digital Inputs
- X103** – Modbus RTU / IEC 60870-5-103 / DNP3.0 RTU, RS485, Terminals
- X104** – IRIG-B00X, incl. System Contact (Supervision Contact)

MRA4-2D0BBB

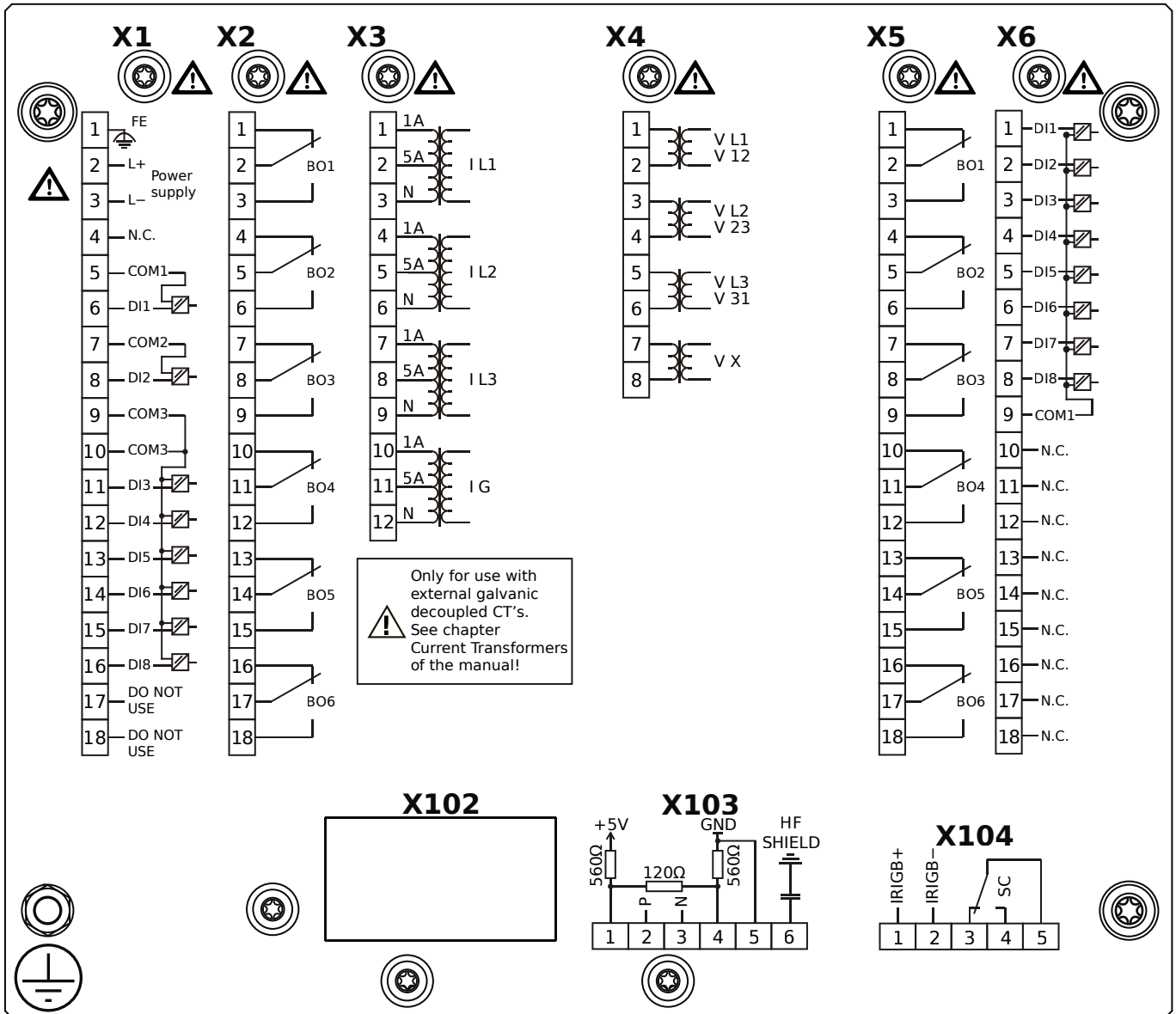

Housing B2, small display, 19" rack mounting

+ Conformal Coating (for installations in harsh environment)

- X1** – DI8-X1: Wide-range power supply unit, incl. 2 non-grouped digital inputs and 6 grouped digital inputs
- X2** – OR6: Assembly Group with 6 Output Relays (Changeover / Form C)
- X3** – TI: Standard current measuring card
- X4** – TU: Card with 4 voltage transformer measuring inputs (0 ... 800 VAC, under UL: 0 ... 600 VAC)
- X5** – OR6: Assembly Group with 6 Output Relays (Changeover / Form C)
- X6** – DI8: Assembly Group with 8 Digital Inputs
- X103** – Modbus RTU / IEC 60870-5-103 / DNP3.0 RTU, RS485, Terminals
- X104** – IRIG-B00X, incl. System Contact (Supervision Contact)

MRA4-2D0BCA

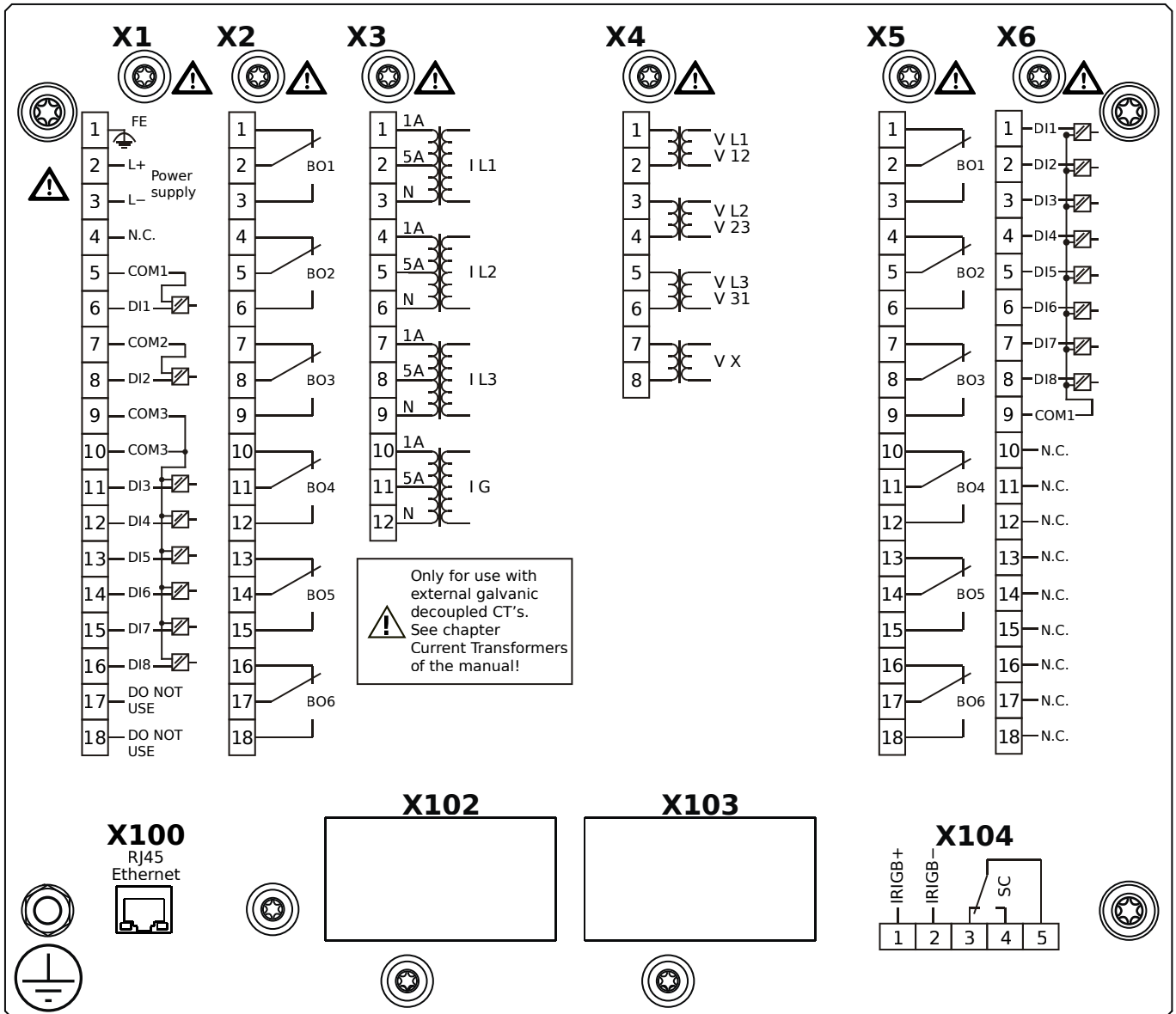

Housing B2, small display, 19" rack mounting

- X1** – DI8-X1: Wide-range power supply unit, incl. 2 non-grouped digital inputs and 6 grouped digital inputs
- X2** – OR6: Assembly Group with 6 Output Relays (Changeover / Form C)
- X3** – TI: Standard current measuring card
- X4** – TU: Card with 4 voltage transformer measuring inputs (0 ... 800 VAC, under UL: 0 ... 600 VAC)
- X5** – OR6: Assembly Group with 6 Output Relays (Changeover / Form C)
- X6** – DI8: Assembly Group with 8 Digital Inputs
- X100** – Modbus TCP / DNP3.0 TCP/UDP, Ethernet interface, 100 Mbit/s, RJ45 (BASE100-FX)
- X104** – IRIG-B00X, incl. System Contact (Supervision Contact)

MRA4-2D0BCB

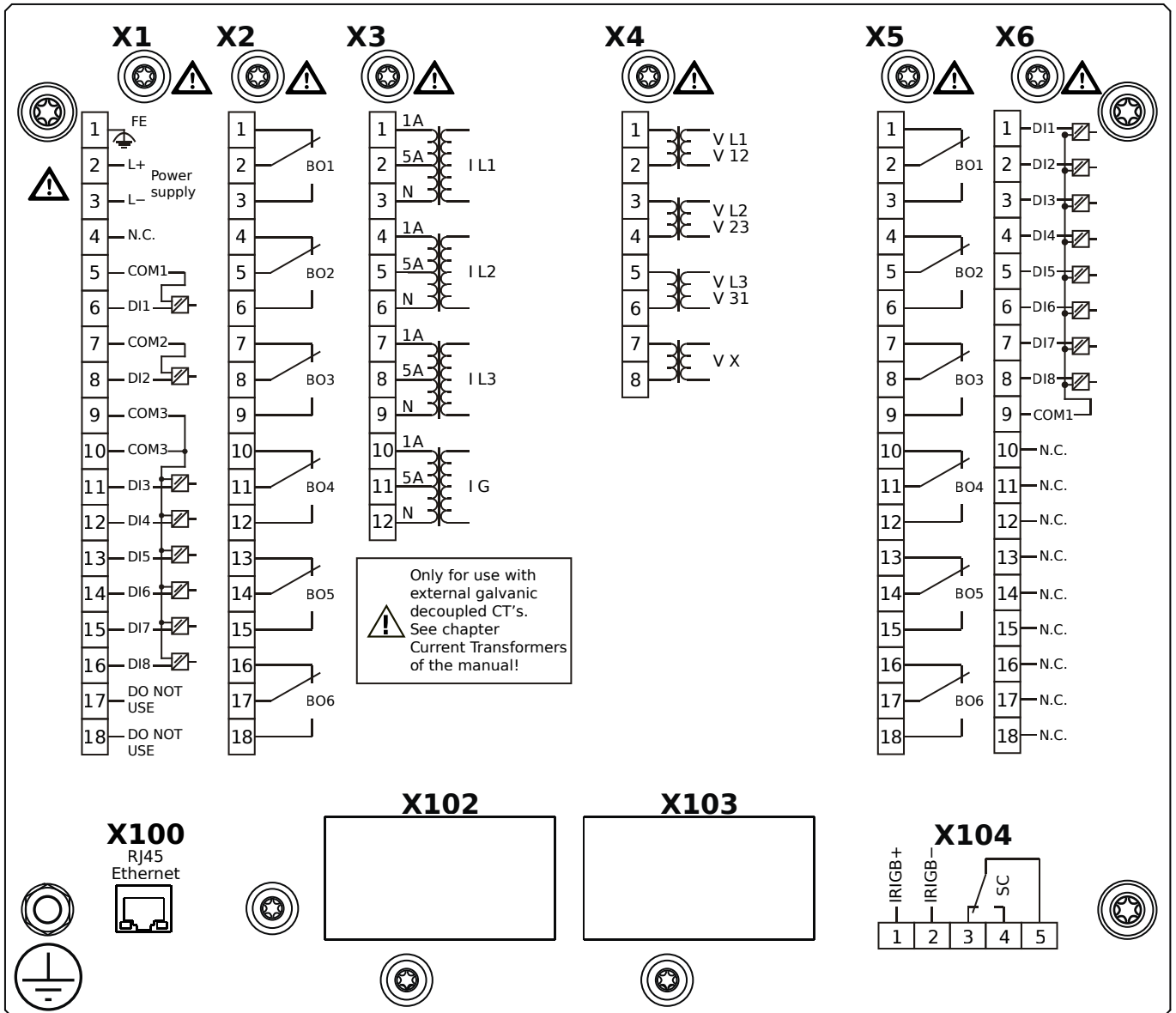

Housing B2, small display, 19" rack mounting

+ Conformal Coating (for installations in harsh environment)

- X1** – DI8-X1: Wide-range power supply unit, incl. 2 non-grouped digital inputs and 6 grouped digital inputs
- X2** – OR6: Assembly Group with 6 Output Relays (Changeover / Form C)
- X3** – TI: Standard current measuring card
- X4** – TU: Card with 4 voltage transformer measuring inputs (0 ... 800 VAC, under UL: 0 ... 600 VAC)
- X5** – OR6: Assembly Group with 6 Output Relays (Changeover / Form C)
- X6** – DI8: Assembly Group with 8 Digital Inputs
- X100** – Modbus TCP / DNP3.0 TCP/UDP, Ethernet interface, 100 Mbit/s, RJ45 (BASE100-FX)
- X104** – IRIG-B00X, incl. System Contact (Supervision Contact)

MRA4-2D0BDA

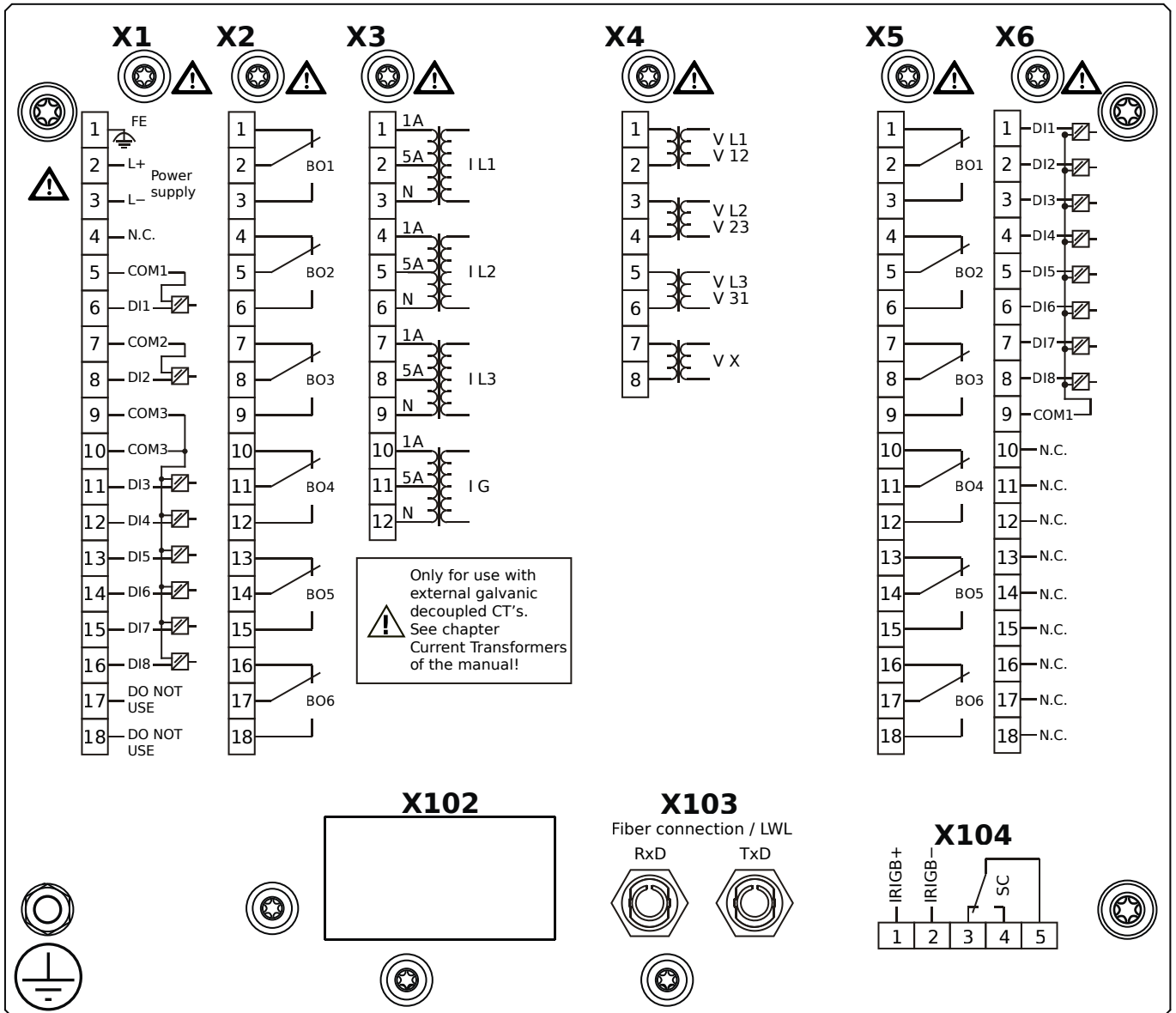

Housing B2, small display, 19" rack mounting

- X1** – DI8-X1: Wide-range power supply unit, incl. 2 non-grouped digital inputs and 6 grouped digital inputs
- X2** – OR6: Assembly Group with 6 Output Relays (Changeover / Form C)
- X3** – TI: Standard current measuring card
- X4** – TU: Card with 4 voltage transformer measuring inputs (0 ... 800 VAC, under UL: 0 ... 600 VAC)
- X5** – OR6: Assembly Group with 6 Output Relays (Changeover / Form C)
- X6** – DI8: Assembly Group with 8 Digital Inputs
- X103** – Profibus-DP, Fiber optics interface, ST Connector
- X104** – IRIG-B00X, incl. System Contact (Supervision Contact)

MRA4-2D0BDB

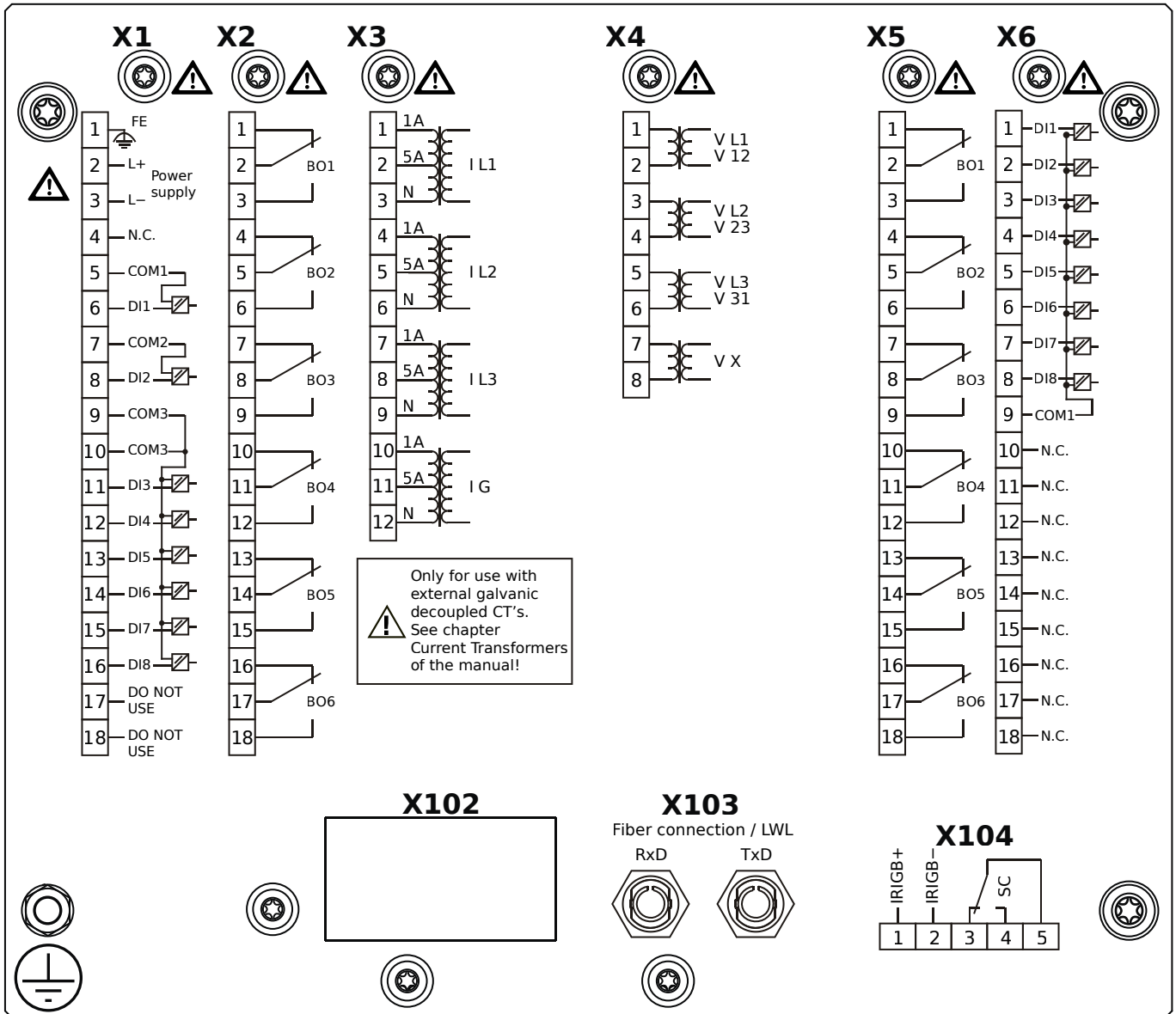

Housing B2, small display, 19" rack mounting

+ Conformal Coating (for installations in harsh environment)

- X1** – DI8-X1: Wide-range power supply unit, incl. 2 non-grouped digital inputs and 6 grouped digital inputs
- X2** – OR6: Assembly Group with 6 Output Relays (Changeover / Form C)
- X3** – TI: Standard current measuring card
- X4** – TU: Card with 4 voltage transformer measuring inputs (0 ... 800 VAC, under UL: 0 ... 600 VAC)
- X5** – OR6: Assembly Group with 6 Output Relays (Changeover / Form C)
- X6** – DI8: Assembly Group with 8 Digital Inputs
- X103** – Profibus-DP, Fiber optics interface, ST Connector
- X104** – IRIG-B00X, incl. System Contact (Supervision Contact)

MRA4-2D0BEA

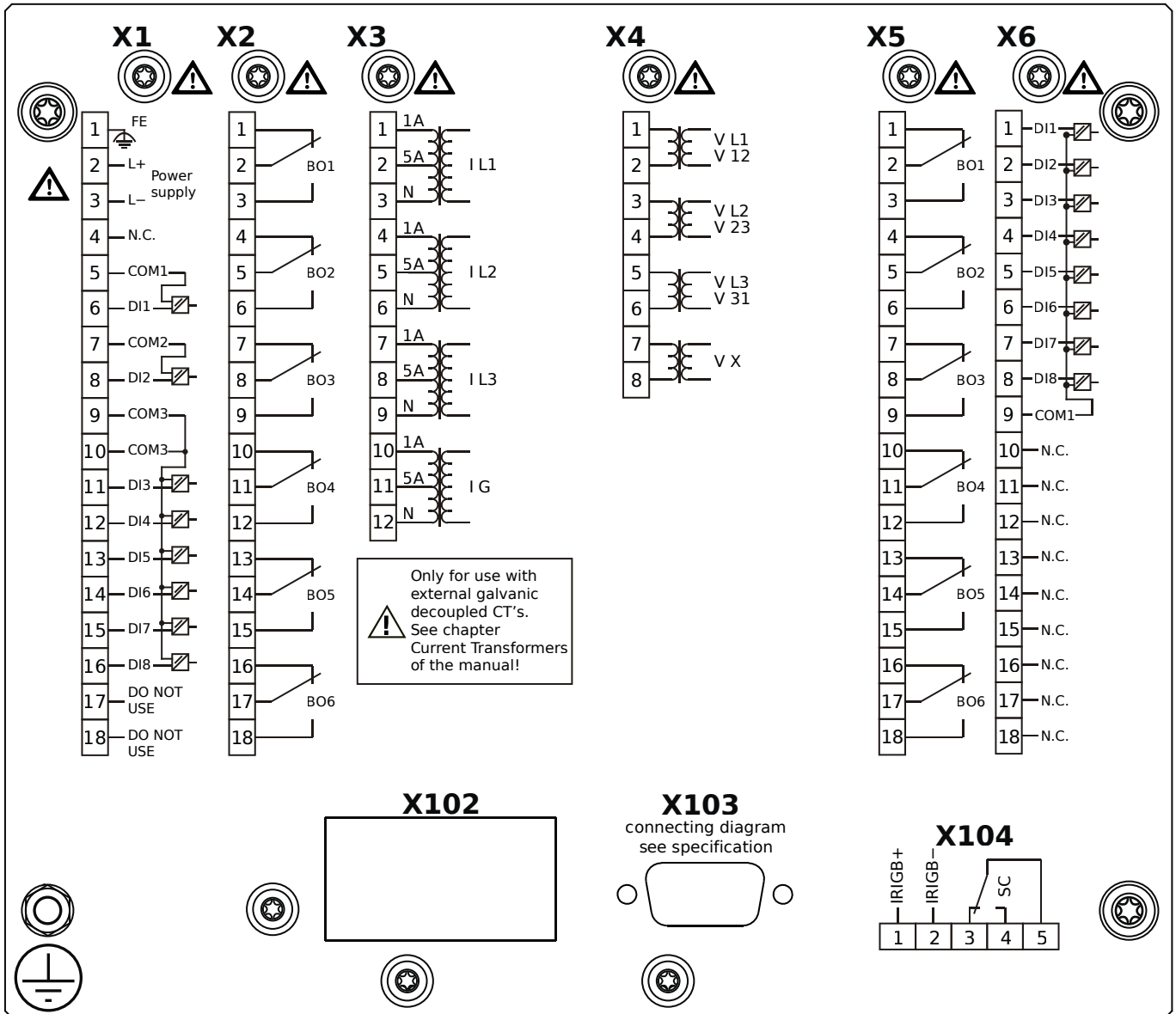

Housing B2, small display, 19" rack mounting

- X1** – DI8-X1: Wide-range power supply unit, incl. 2 non-grouped digital inputs and 6 grouped digital inputs
- X2** – OR6: Assembly Group with 6 Output Relays (Changeover / Form C)
- X3** – TI: Standard current measuring card
- X4** – TU: Card with 4 voltage transformer measuring inputs (0 ... 800 VAC, under UL: 0 ... 600 VAC)
- X5** – OR6: Assembly Group with 6 Output Relays (Changeover / Form C)
- X6** – DI8: Assembly Group with 8 Digital Inputs
- X103** – Profibus-DP, RS485, D-SUB
- X104** – IRIG-B00X, incl. System Contact (Supervision Contact)

MRA4-2D0BEB

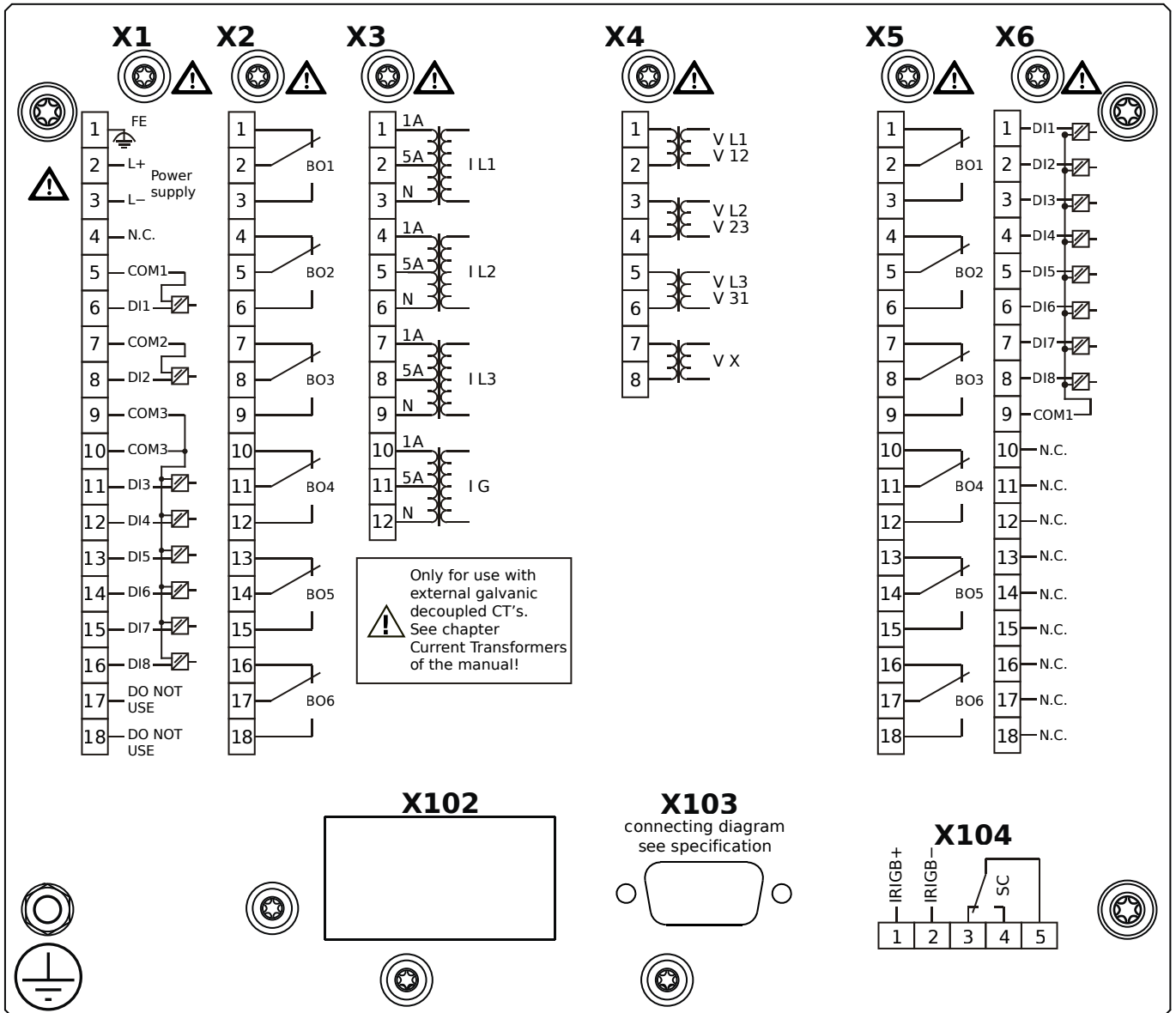

Housing B2, small display, 19" rack mounting

+ Conformal Coating (for installations in harsh environment)

- X1** – DI8-X1: Wide-range power supply unit, incl. 2 non-grouped digital inputs and 6 grouped digital inputs
- X2** – OR6: Assembly Group with 6 Output Relays (Changeover / Form C)
- X3** – TI: Standard current measuring card
- X4** – TU: Card with 4 voltage transformer measuring inputs (0 ... 800 VAC, under UL: 0 ... 600 VAC)
- X5** – OR6: Assembly Group with 6 Output Relays (Changeover / Form C)
- X6** – DI8: Assembly Group with 8 Digital Inputs
- X103** – Profibus-DP, RS485, D-SUB
- X104** – IRIG-B00X, incl. System Contact (Supervision Contact)

MRA4-2D0BFA

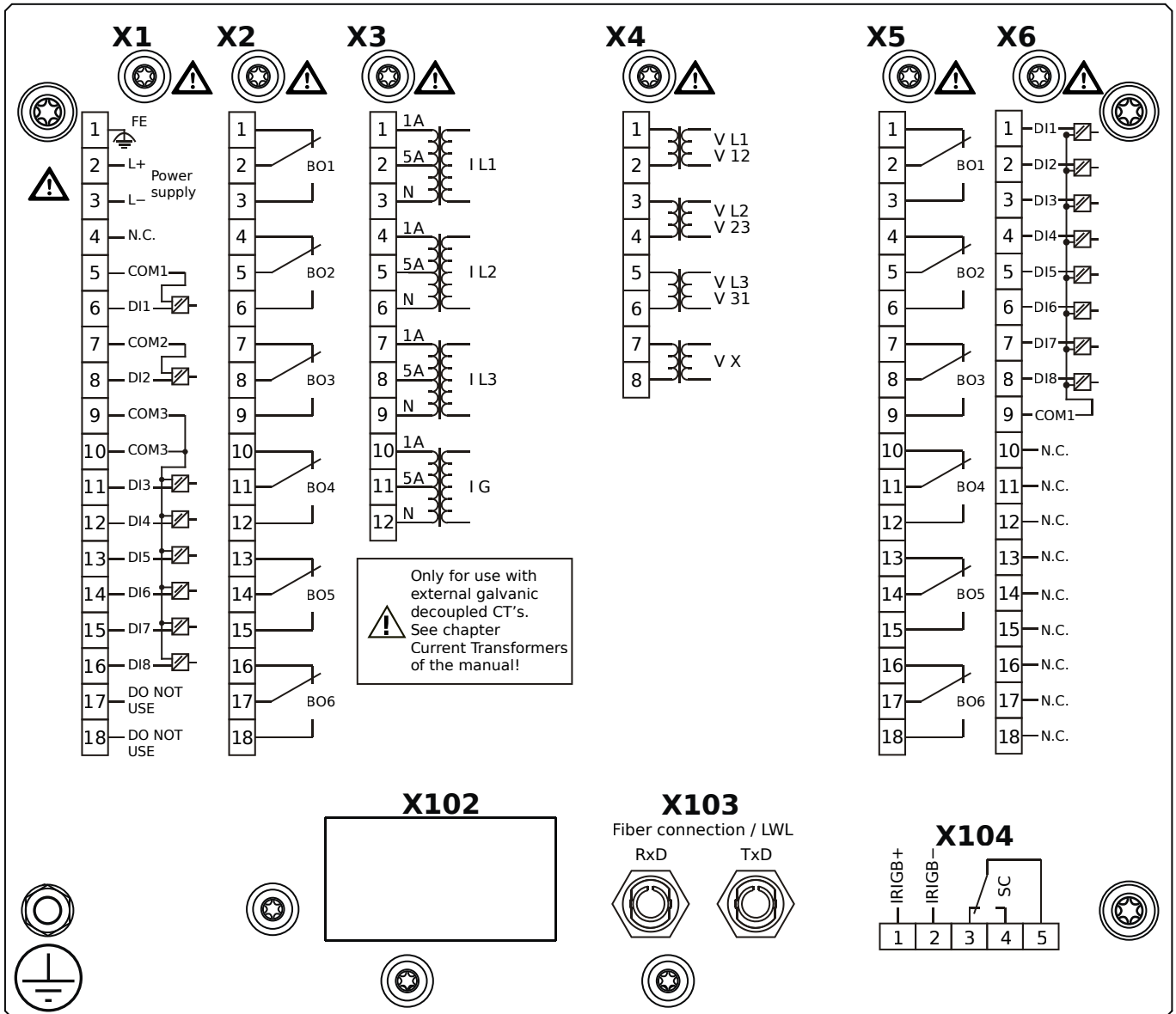

Housing B2, small display, 19" rack mounting

- X1** – DI8-X1: Wide-range power supply unit, incl. 2 non-grouped digital inputs and 6 grouped digital inputs
- X2** – OR6: Assembly Group with 6 Output Relays (Changeover / Form C)
- X3** – TI: Standard current measuring card
- X4** – TU: Card with 4 voltage transformer measuring inputs (0 ... 800 VAC, under UL: 0 ... 600 VAC)
- X5** – OR6: Assembly Group with 6 Output Relays (Changeover / Form C)
- X6** – DI8: Assembly Group with 8 Digital Inputs
- X103** – Modbus RTU / IEC 60870-5-103 / DNP3.0 RTU, Fiber optics interface, ST Connector
- X104** – IRIG-B00X, incl. System Contact (Supervision Contact)

MRA4-2D0BFB

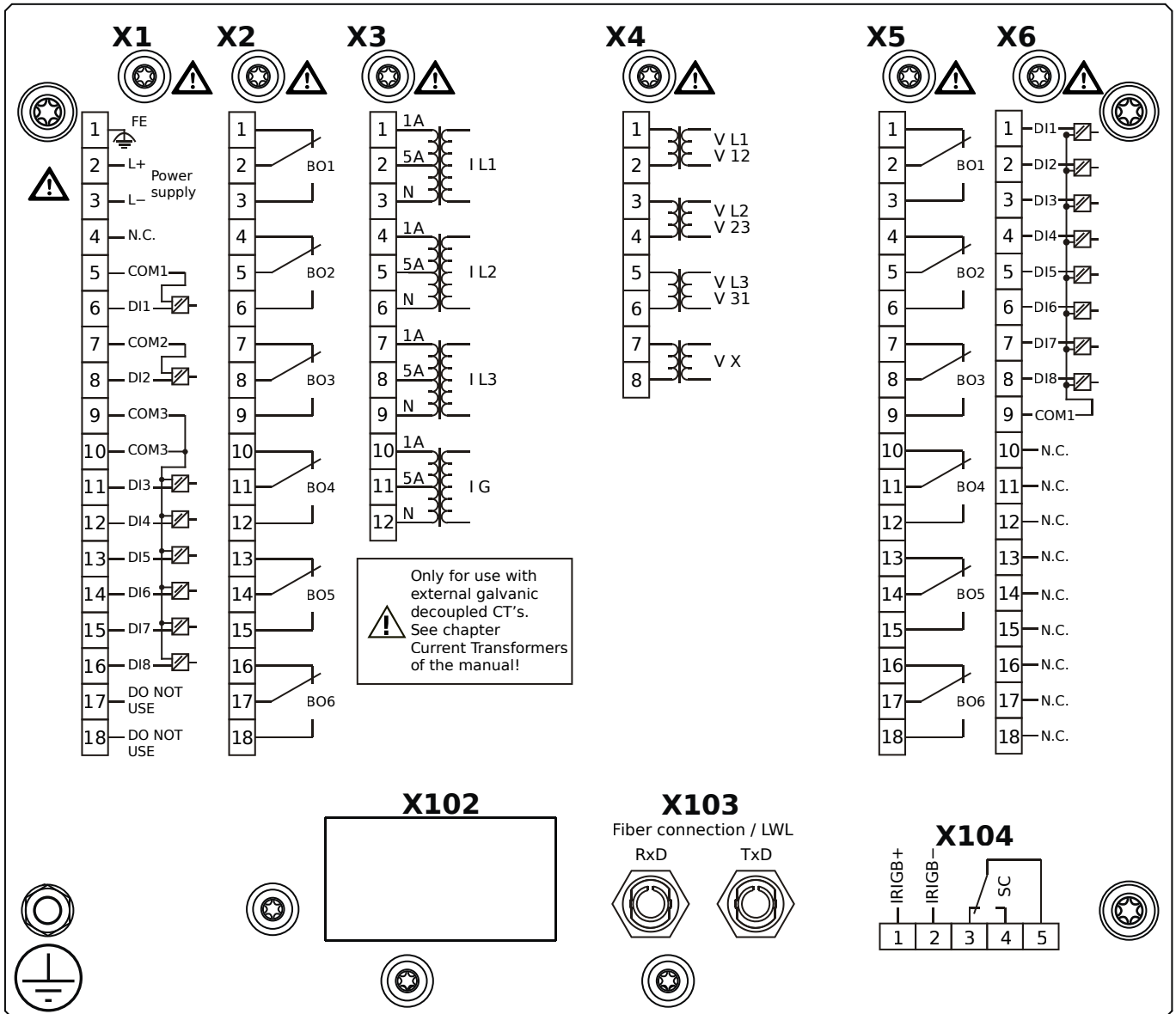

Housing B2, small display, 19" rack mounting

+ Conformal Coating (for installations in harsh environment)

- X1** – DI8-X1: Wide-range power supply unit, incl. 2 non-grouped digital inputs and 6 grouped digital inputs
- X2** – OR6: Assembly Group with 6 Output Relays (Changeover / Form C)
- X3** – TI: Standard current measuring card
- X4** – TU: Card with 4 voltage transformer measuring inputs (0 ... 800 VAC, under UL: 0 ... 600 VAC)
- X5** – OR6: Assembly Group with 6 Output Relays (Changeover / Form C)
- X6** – DI8: Assembly Group with 8 Digital Inputs
- X103** – Modbus RTU / IEC 60870-5-103 / DNP3.0 RTU, Fiber optics interface, ST Connector
- X104** – IRIG-B00X, incl. System Contact (Supervision Contact)

MRA4-2D0BGA

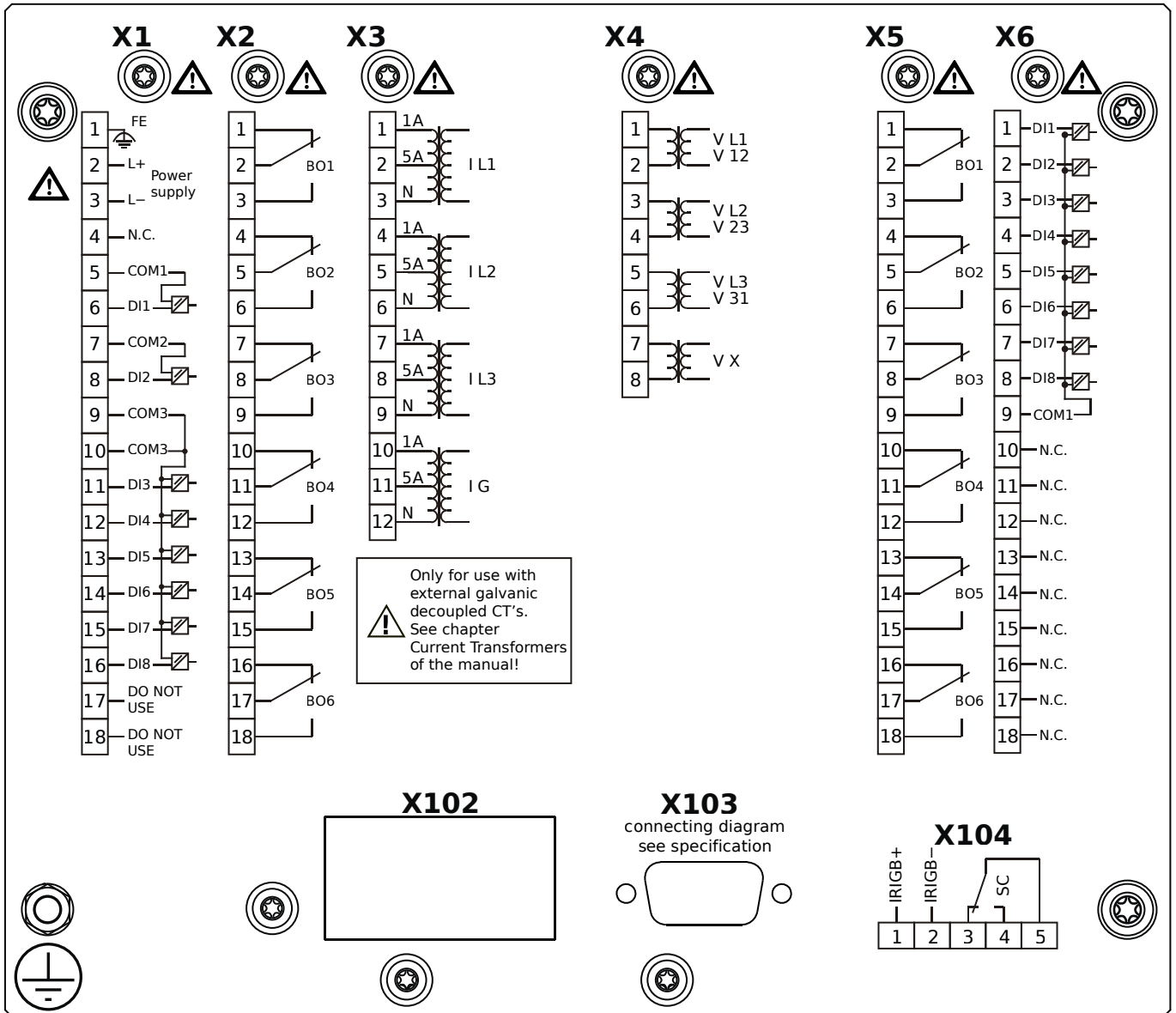

Housing B2, small display, 19" rack mounting

- X1** – DI8-X1: Wide-range power supply unit, incl. 2 non-grouped digital inputs and 6 grouped digital inputs
- X2** – OR6: Assembly Group with 6 Output Relays (Changeover / Form C)
- X3** – TI: Standard current measuring card
- X4** – TU: Card with 4 voltage transformer measuring inputs (0 ... 800 VAC, under UL: 0 ... 600 VAC)
- X5** – OR6: Assembly Group with 6 Output Relays (Changeover / Form C)
- X6** – DI8: Assembly Group with 8 Digital Inputs
- X103** – Modbus RTU / IEC 60870-5-103 / DNP3.0 RTU, RS485, D-SUB
- X104** – IRIG-B00X, incl. System Contact (Supervision Contact)

MRA4-2D0BGB

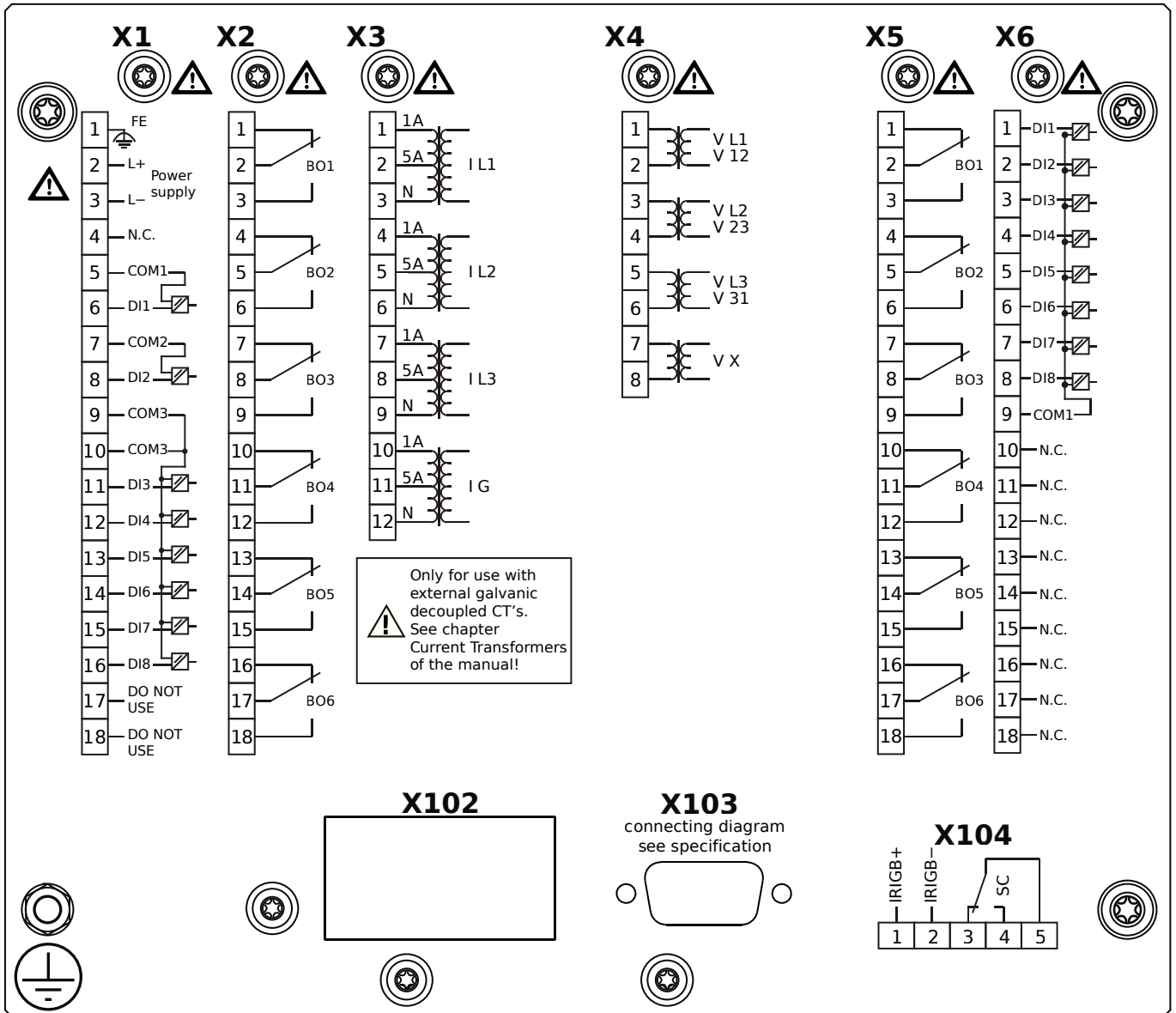

Housing B2, small display, 19" rack mounting

+ Conformal Coating (for installations in harsh environment)

- X1** – DI8-X1: Wide-range power supply unit, incl. 2 non-grouped digital inputs and 6 grouped digital inputs
- X2** – OR6: Assembly Group with 6 Output Relays (Changeover / Form C)
- X3** – TI: Standard current measuring card
- X4** – TU: Card with 4 voltage transformer measuring inputs (0 ... 800 VAC, under UL: 0 ... 600 VAC)
- X5** – OR6: Assembly Group with 6 Output Relays (Changeover / Form C)
- X6** – DI8: Assembly Group with 8 Digital Inputs
- X103** – Modbus RTU / IEC 60870-5-103 / DNP3.0 RTU, RS485, D-SUB
- X104** – IRIG-B00X, incl. System Contact (Supervision Contact)

MRA4-2D0BHA

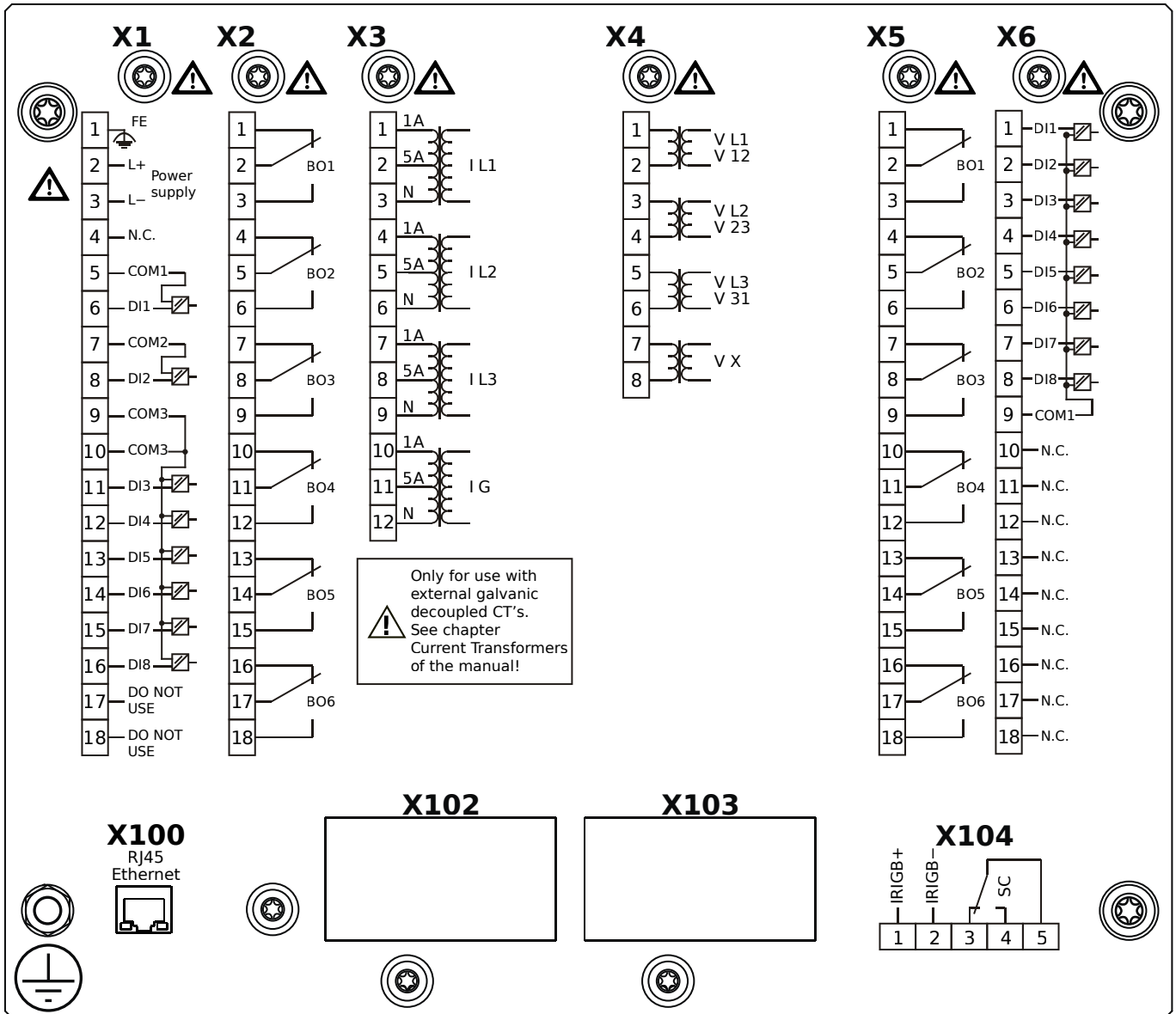

Housing B2, small display, 19" rack mounting

- X1** – DI8-X1: Wide-range power supply unit, incl. 2 non-grouped digital inputs and 6 grouped digital inputs
- X2** – OR6: Assembly Group with 6 Output Relays (Changeover / Form C)
- X3** – TI: Standard current measuring card
- X4** – TU: Card with 4 voltage transformer measuring inputs (0 ... 800 VAC, under UL: 0 ... 600 VAC)
- X5** – OR6: Assembly Group with 6 Output Relays (Changeover / Form C)
- X6** – DI8: Assembly Group with 8 Digital Inputs
- X100** – IEC 61850 / Modbus TCP / DNP3.0 TCP/UDP, Ethernet interface, 100 Mbit/s, RJ45 (BASE100-FX)
- X104** – IRIG-B00X, incl. System Contact (Supervision Contact)

MRA4-2D0BHB

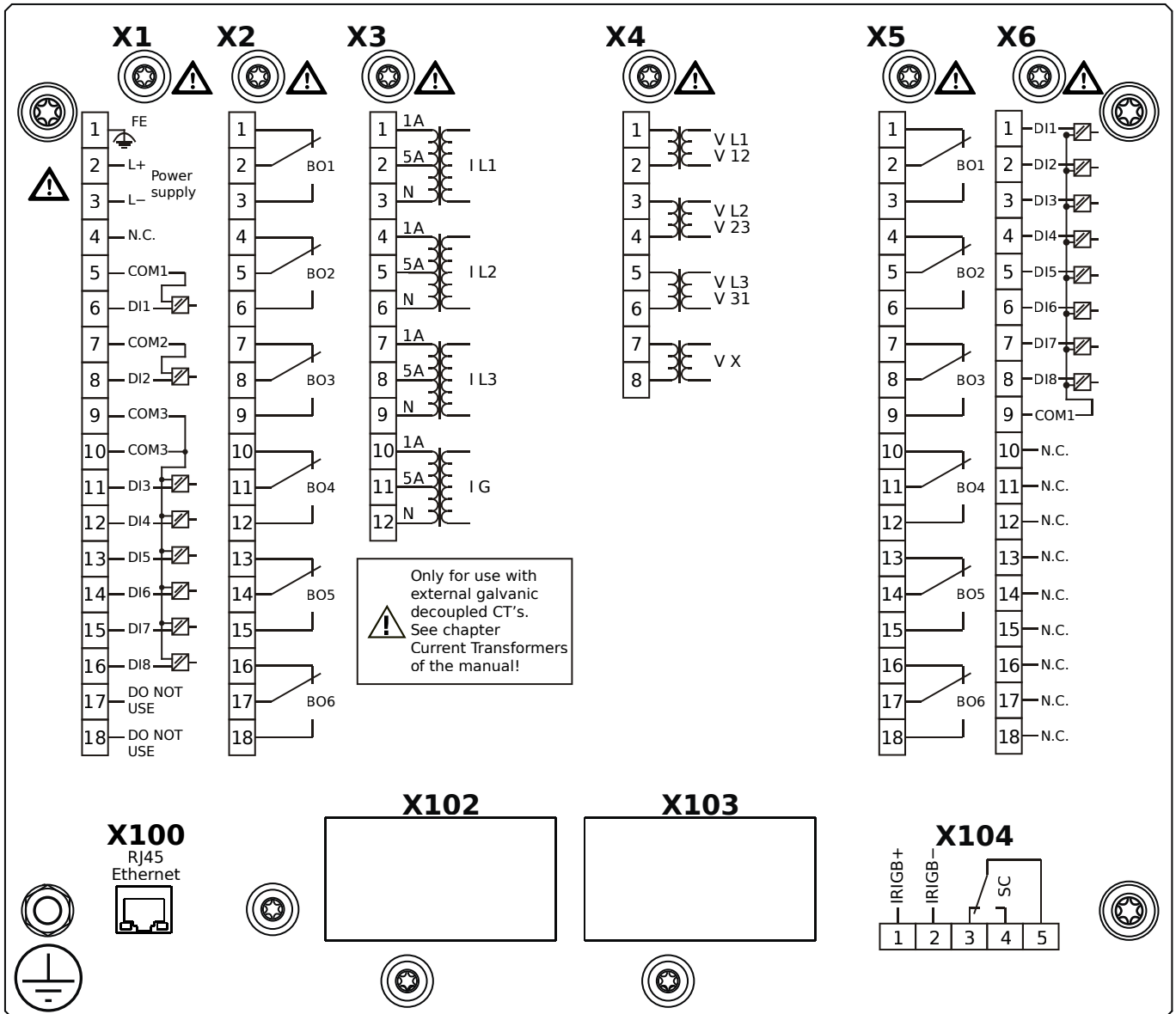

Housing B2, small display, 19" rack mounting

+ Conformal Coating (for installations in harsh environment)

- X1** – DI8-X1: Wide-range power supply unit, incl. 2 non-grouped digital inputs and 6 grouped digital inputs
- X2** – OR6: Assembly Group with 6 Output Relays (Changeover / Form C)
- X3** – TI: Standard current measuring card
- X4** – TU: Card with 4 voltage transformer measuring inputs (0 ... 800 VAC, under UL: 0 ... 600 VAC)
- X5** – OR6: Assembly Group with 6 Output Relays (Changeover / Form C)
- X6** – DI8: Assembly Group with 8 Digital Inputs
- X100** – IEC 61850 / Modbus TCP / DNP3.0 TCP/UDP, Ethernet interface, 100 Mbit/s, RJ45 (BASE100-FX)
- X104** – IRIG-B00X, incl. System Contact (Supervision Contact)

MRA4-2D0BIA

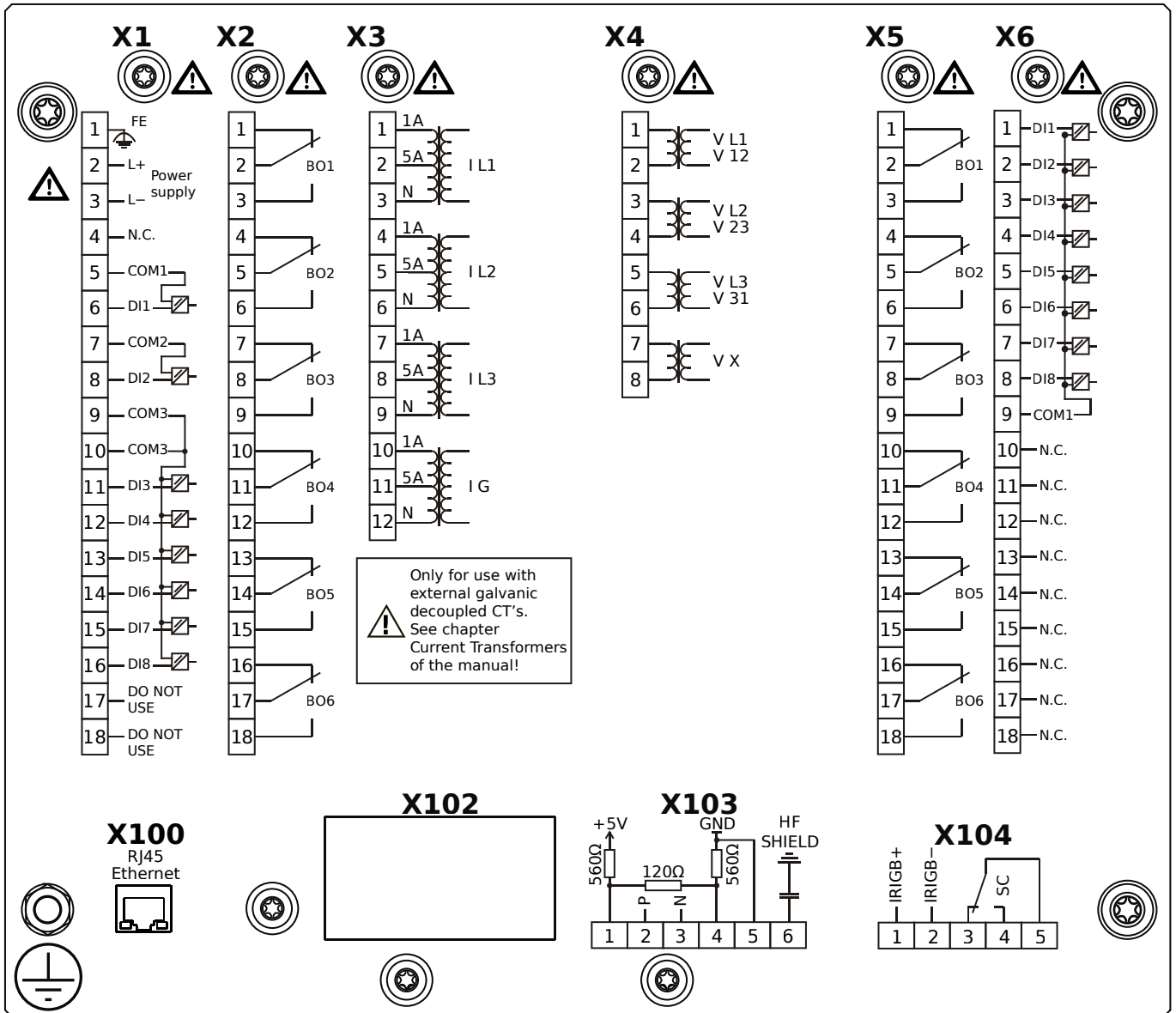

Housing B2, small display, 19" rack mounting

- X1** – DI8-X1: Wide-range power supply unit, incl. 2 non-grouped digital inputs and 6 grouped digital inputs
- X2** – OR6: Assembly Group with 6 Output Relays (Changeover / Form C)
- X3** – TI: Standard current measuring card
- X4** – TU: Card with 4 voltage transformer measuring inputs (0 ... 800 VAC, under UL: 0 ... 600 VAC)
- X5** – OR6: Assembly Group with 6 Output Relays (Changeover / Form C)
- X6** – DI8: Assembly Group with 8 Digital Inputs
- X100** – Modbus TCP / DNP3.0 TCP/UDP, Ethernet interface, 100 Mbit/s, RJ45 (BASE100-FX)
- X103** – IEC 60870-5-103 / Modbus RTU / DNP3.0 RTU, RS485, Terminals
- X104** – IRIG-B00X, incl. System Contact (Supervision Contact)

MRA4-2D0BIB

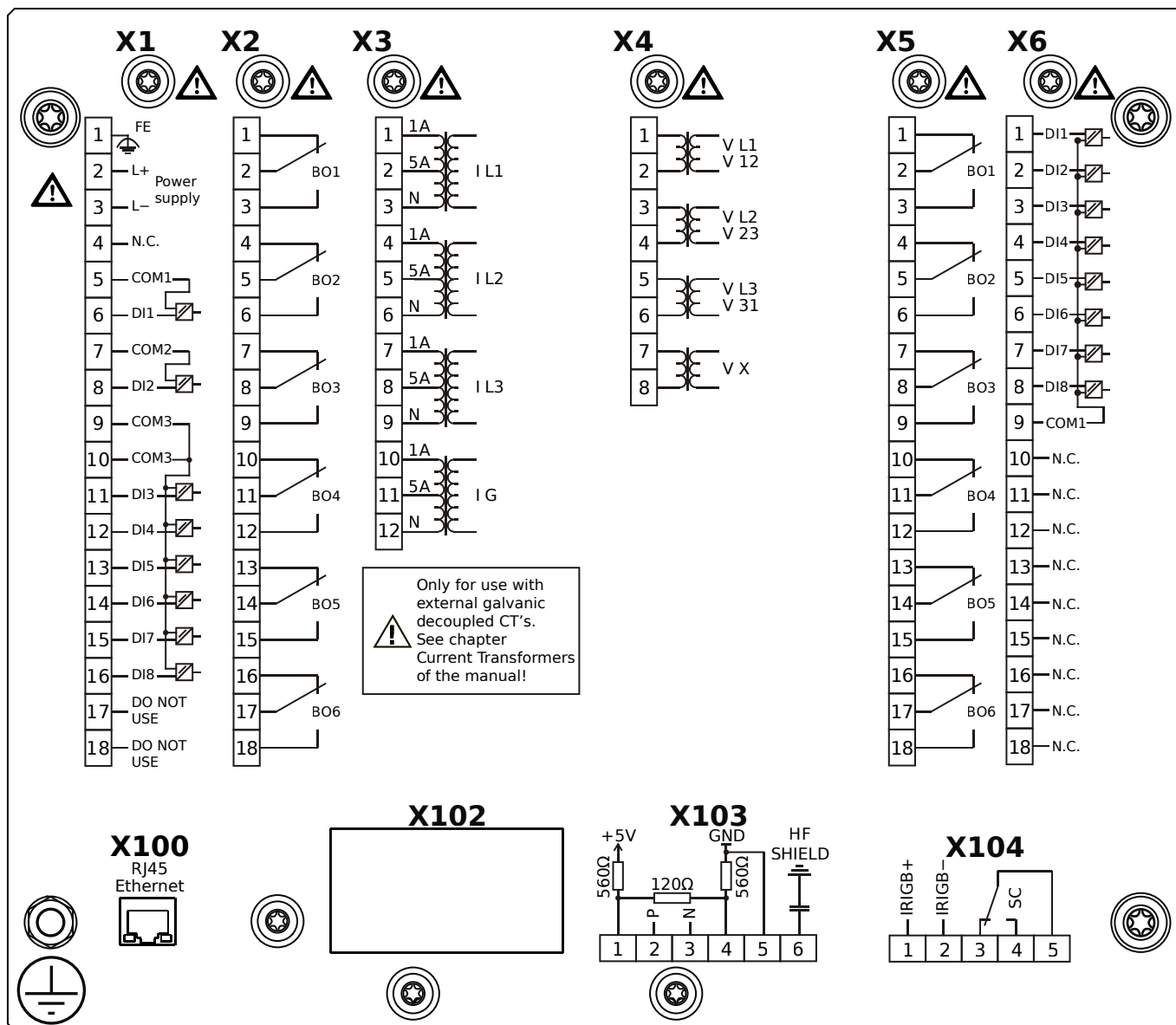

Housing B2, small display, 19" rack mounting

+ Conformal Coating (for installations in harsh environment)

- X1** – DI8-X1: Wide-range power supply unit, incl. 2 non-grouped digital inputs and 6 grouped digital inputs
- X2** – OR6: Assembly Group with 6 Output Relays (Changeover / Form C)
- X3** – TI: Standard current measuring card
- X4** – TU: Card with 4 voltage transformer measuring inputs (0 ... 800 VAC, under UL: 0 ... 600 VAC)
- X5** – OR6: Assembly Group with 6 Output Relays (Changeover / Form C)
- X6** – DI8: Assembly Group with 8 Digital Inputs
- X100** – Modbus TCP / DNP3.0 TCP/UDP, Ethernet interface, 100 Mbit/s, RJ45 (BASE100-FX)
- X103** – IEC 60870-5-103 / Modbus RTU / DNP3.0 RTU, RS485, Terminals
- X104** – IRIG-B00X, incl. System Contact (Supervision Contact)

MRA4-2D0BKA

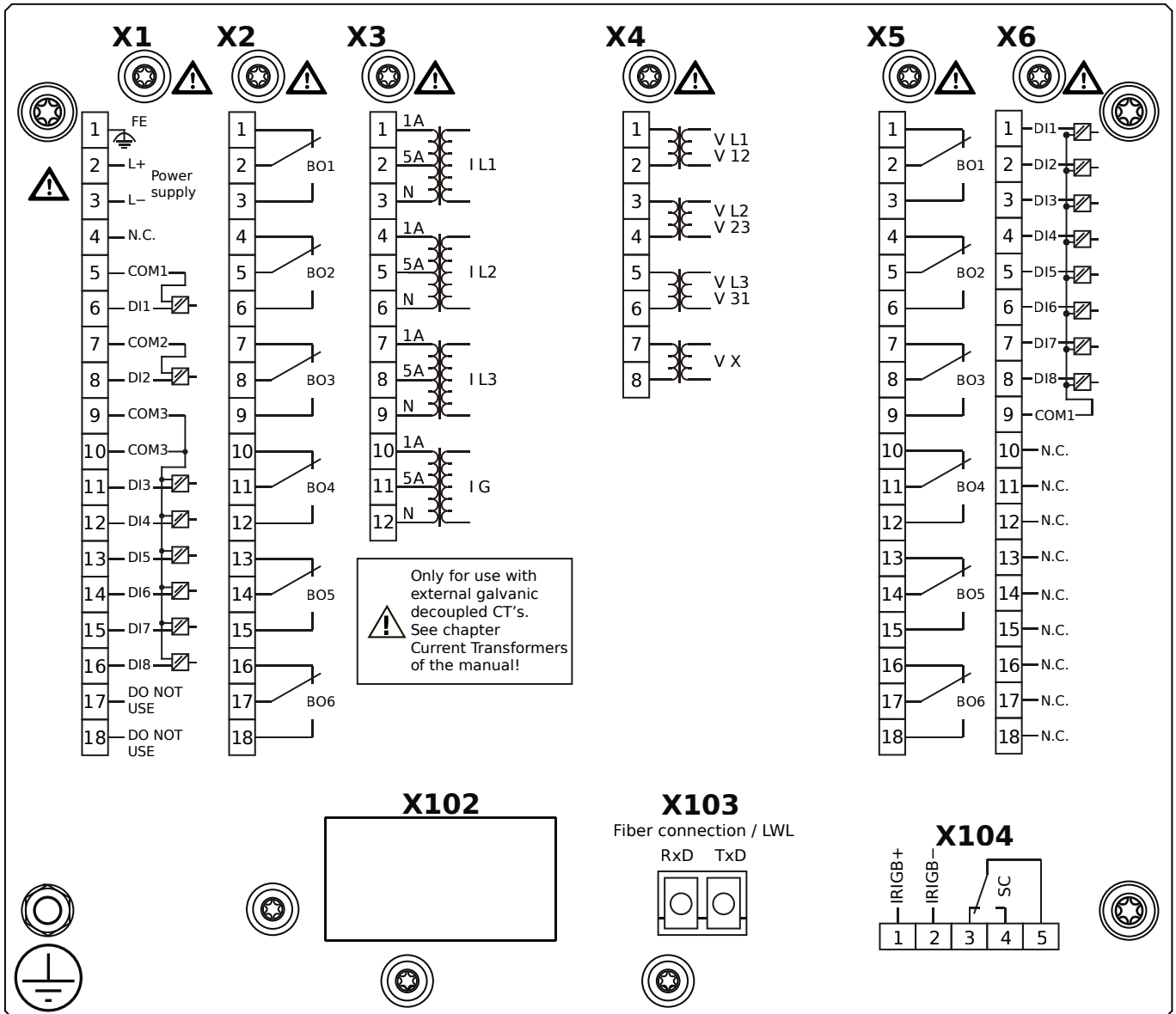

Housing B2, small display, 19" rack mounting

- X1** – DI8-X1: Wide-range power supply unit, incl. 2 non-grouped digital inputs and 6 grouped digital inputs
- X2** – OR6: Assembly Group with 6 Output Relays (Changeover / Form C)
- X3** – TI: Standard current measuring card
- X4** – TU: Card with 4 voltage transformer measuring inputs (0 ... 800 VAC, under UL: 0 ... 600 VAC)
- X5** – OR6: Assembly Group with 6 Output Relays (Changeover / Form C)
- X6** – DI8: Assembly Group with 8 Digital Inputs
- X103** – IEC 61850 / Modbus TCP / DNP3.0 TCP/UDP, Fiber optics interface, LC Connector
- X104** – IRIG-B00X, incl. System Contact (Supervision Contact)

MRA4-2D0BKB

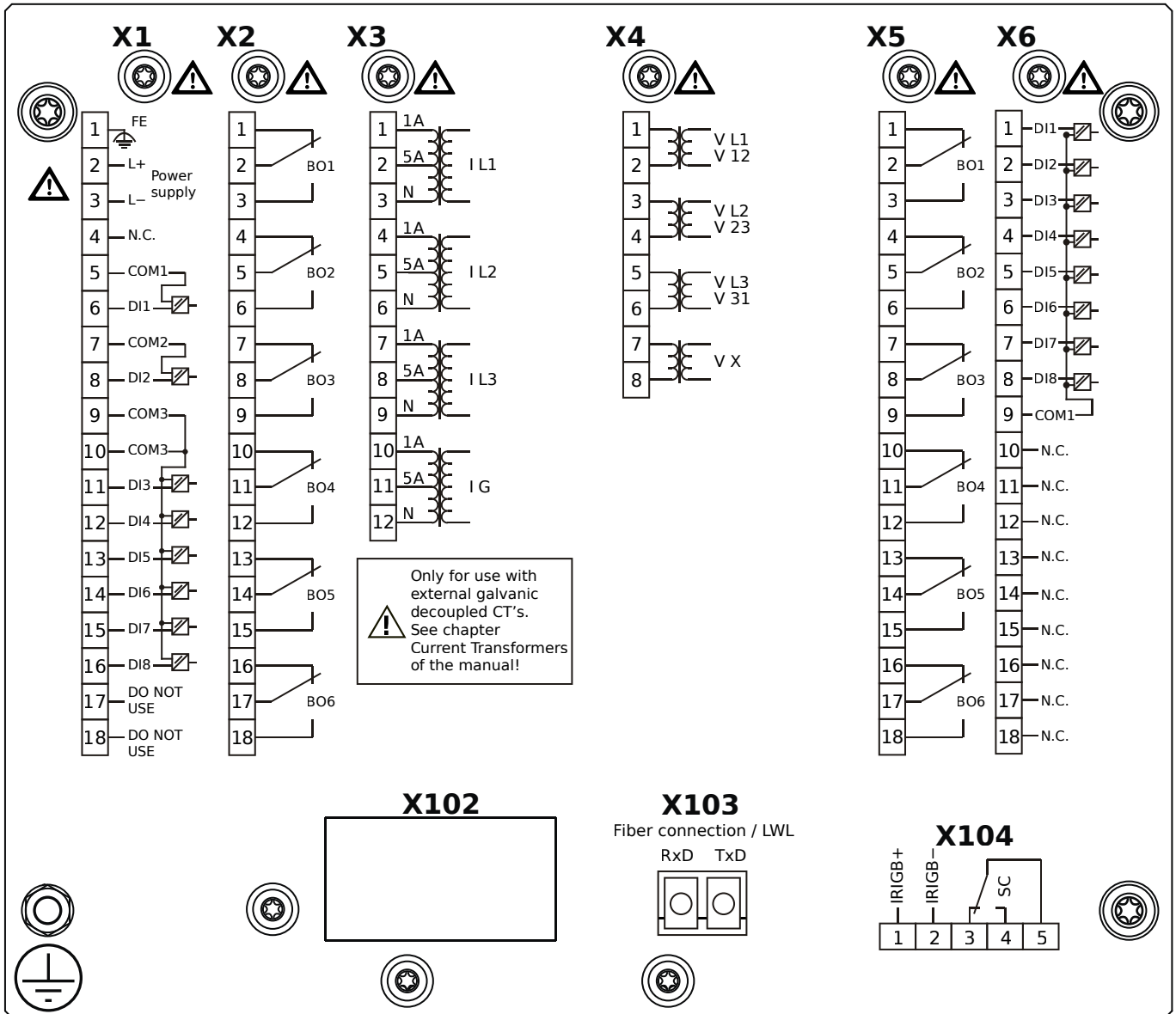

Housing B2, small display, 19" rack mounting

+ Conformal Coating (for installations in harsh environment)

- X1** – DI8-X1: Wide-range power supply unit, incl. 2 non-grouped digital inputs and 6 grouped digital inputs
- X2** – OR6: Assembly Group with 6 Output Relays (Changeover / Form C)
- X3** – TI: Standard current measuring card
- X4** – TU: Card with 4 voltage transformer measuring inputs (0 ... 800 VAC, under UL: 0 ... 600 VAC)
- X5** – OR6: Assembly Group with 6 Output Relays (Changeover / Form C)
- X6** – DI8: Assembly Group with 8 Digital Inputs
- X103** – IEC 61850 / Modbus TCP / DNP3.0 TCP/UDP, Fiber optics interface, LC Connector
- X104** – IRIG-B00X, incl. System Contact (Supervision Contact)

MRA4-2D0BLA

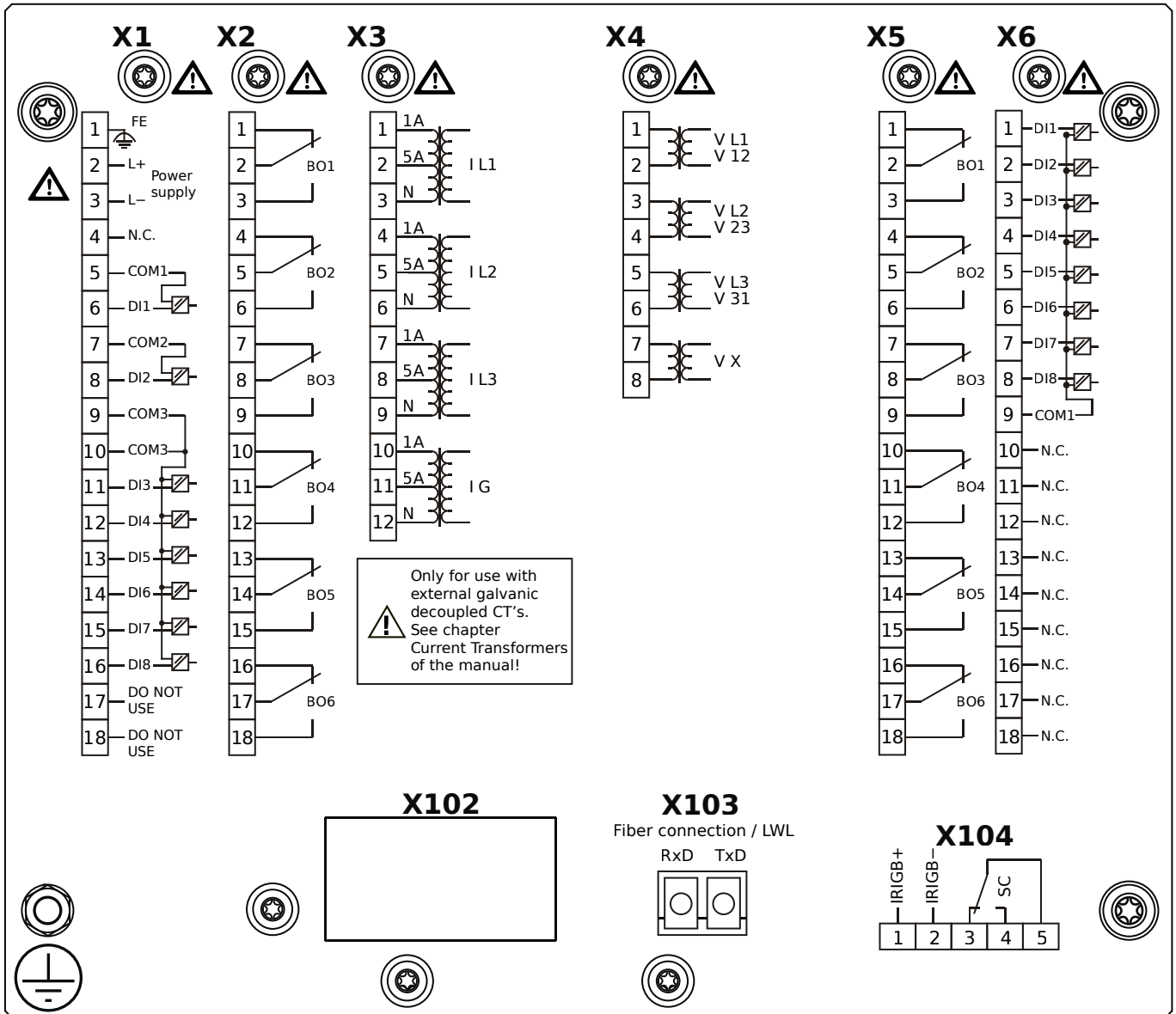

Housing B2, small display, 19" rack mounting

- X1** – DI8-X1: Wide-range power supply unit, incl. 2 non-grouped digital inputs and 6 grouped digital inputs
- X2** – OR6: Assembly Group with 6 Output Relays (Changeover / Form C)
- X3** – TI: Standard current measuring card
- X4** – TU: Card with 4 voltage transformer measuring inputs (0 ... 800 VAC, under UL: 0 ... 600 VAC)
- X5** – OR6: Assembly Group with 6 Output Relays (Changeover / Form C)
- X6** – DI8: Assembly Group with 8 Digital Inputs
- X103** – Modbus TCP / DNP3.0 TCP/UDP, Fiber optics interface, LC Connector
- X104** – IRIG-B00X, incl. System Contact (Supervision Contact)

MRA4-2D0BLB

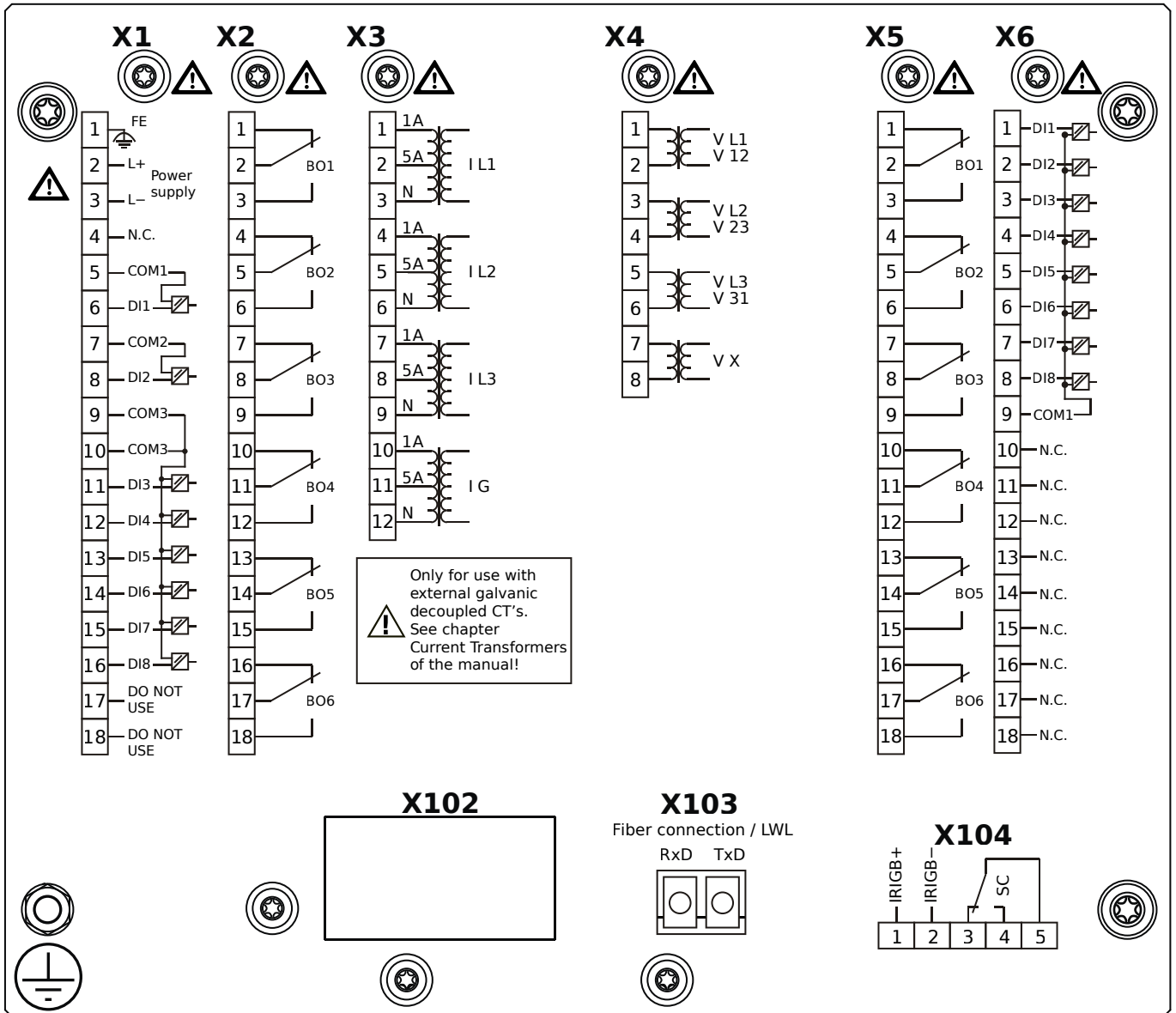

Housing B2, small display, 19" rack mounting

+ Conformal Coating (for installations in harsh environment)

- X1** – DI8-X1: Wide-range power supply unit, incl. 2 non-grouped digital inputs and 6 grouped digital inputs
- X2** – OR6: Assembly Group with 6 Output Relays (Changeover / Form C)
- X3** – TI: Standard current measuring card
- X4** – TU: Card with 4 voltage transformer measuring inputs (0 ... 800 VAC, under UL: 0 ... 600 VAC)
- X5** – OR6: Assembly Group with 6 Output Relays (Changeover / Form C)
- X6** – DI8: Assembly Group with 8 Digital Inputs
- X103** – Modbus TCP / DNP3.0 TCP/UDP, Fiber optics interface, LC Connector
- X104** – IRIG-B00X, incl. System Contact (Supervision Contact)

MRA4-2D0BTA

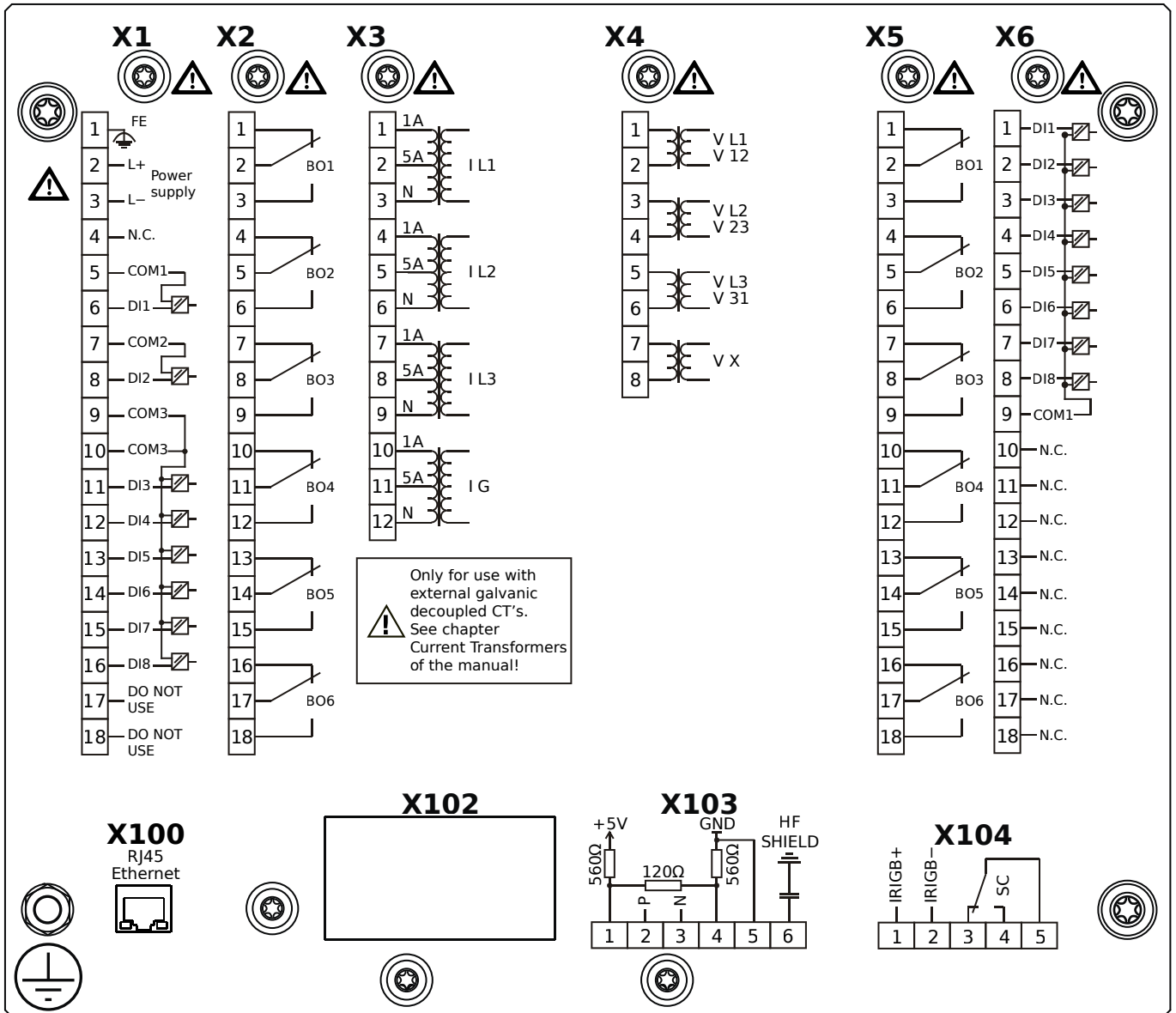

Housing B2, small display, 19" rack mounting

- X1** – DI8-X1: Wide-range power supply unit, incl. 2 non-grouped digital inputs and 6 grouped digital inputs
- X2** – OR6: Assembly Group with 6 Output Relays (Changeover / Form C)
- X3** – TI: Standard current measuring card
- X4** – TU: Card with 4 voltage transformer measuring inputs (0 ... 800 VAC, under UL: 0 ... 600 VAC)
- X5** – OR6: Assembly Group with 6 Output Relays (Changeover / Form C)
- X6** – DI8: Assembly Group with 8 Digital Inputs
- X100** – IEC 61850 / Modbus TCP / DNP3.0 TCP/UDP, Ethernet interface, 100 Mbit/s, RJ45 (BASE100-FX)
- X103** – IEC 60870-5-103 / Modbus RTU / DNP3.0 RTU, RS485, Terminals
- X104** – IRIG-B00X, incl. System Contact (Supervision Contact)

MRA4-2D0BTB

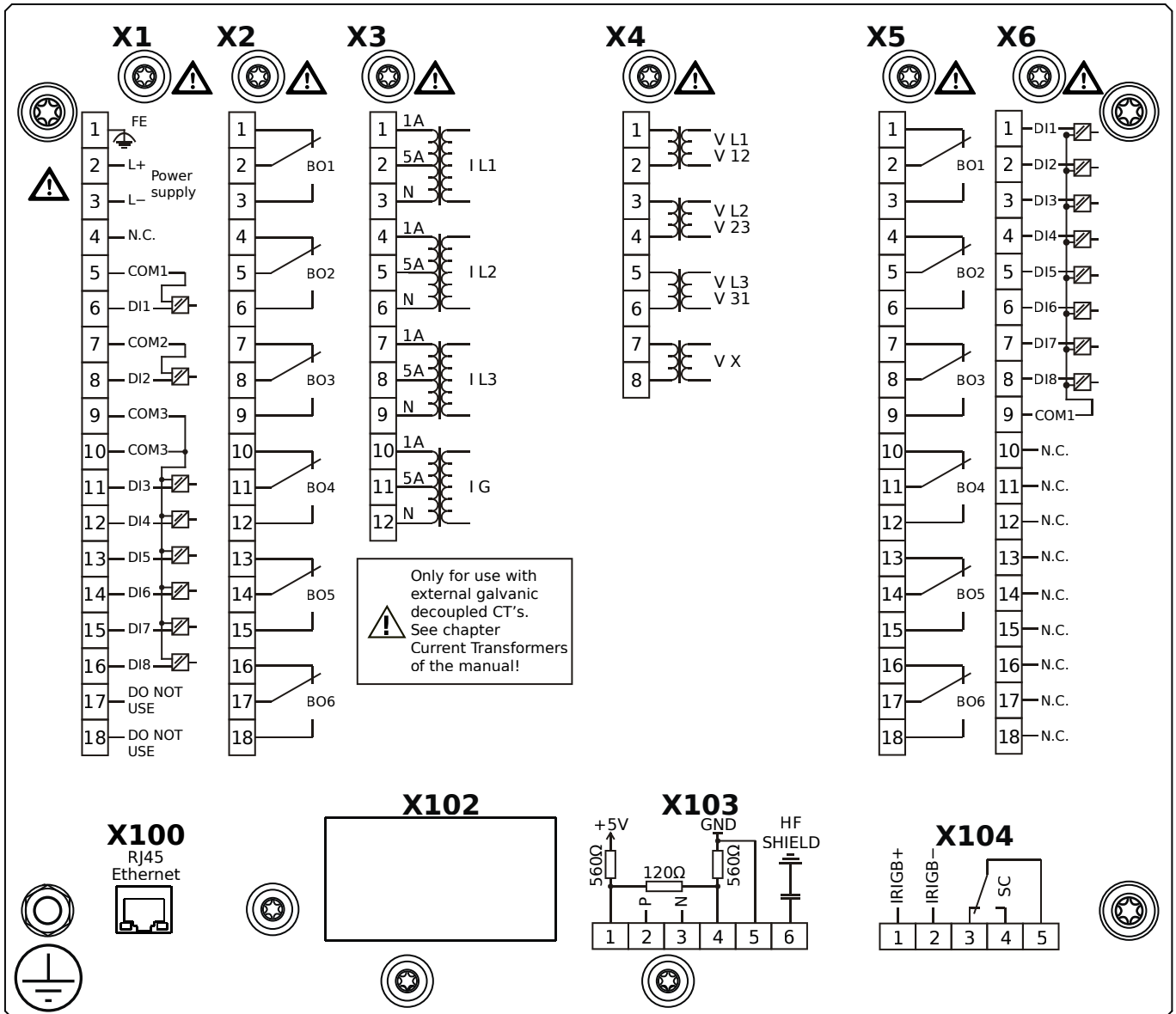

Housing B2, small display, 19" rack mounting

+ Conformal Coating (for installations in harsh environment)

- X1** – DI8-X1: Wide-range power supply unit, incl. 2 non-grouped digital inputs and 6 grouped digital inputs
- X2** – OR6: Assembly Group with 6 Output Relays (Changeover / Form C)
- X3** – TI: Standard current measuring card
- X4** – TU: Card with 4 voltage transformer measuring inputs (0 ... 800 VAC, under UL: 0 ... 600 VAC)
- X5** – OR6: Assembly Group with 6 Output Relays (Changeover / Form C)
- X6** – DI8: Assembly Group with 8 Digital Inputs
- X100** – IEC 61850 / Modbus TCP / DNP3.0 TCP/UDP, Ethernet interface, 100 Mbit/s, RJ45 (BASE100-FX)
- X103** – IEC 60870-5-103 / Modbus RTU / DNP3.0 RTU, RS485, Terminals
- X104** – IRIG-B00X, incl. System Contact (Supervision Contact)

MRA4-2D1AAA

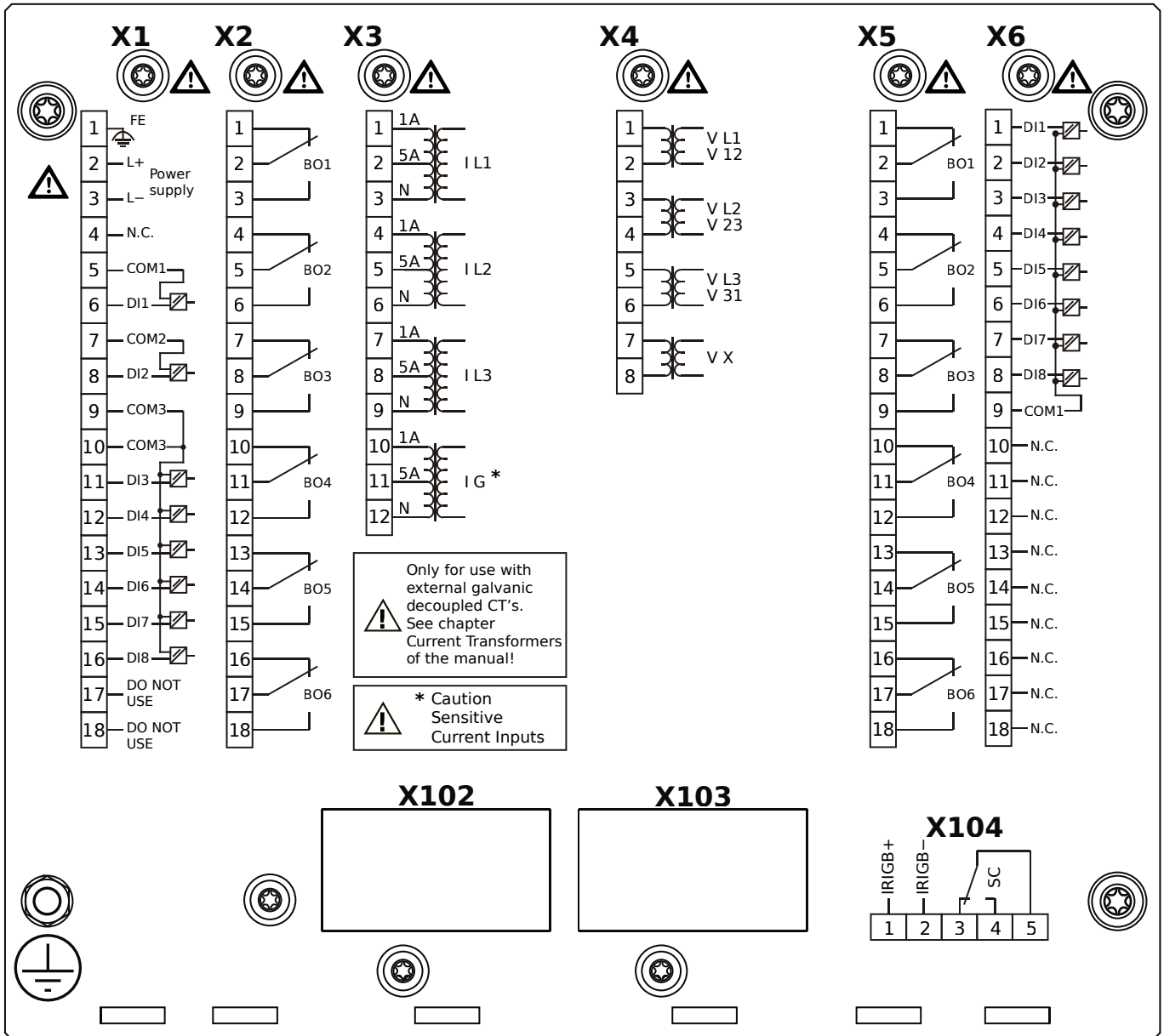

Housing B2, small display, door mounting

- X1** – DI8-X1: Wide-range power supply unit, incl. 2 non-grouped digital inputs and 6 grouped digital inputs
- X2** – OR6: Assembly Group with 6 Output Relays (Changeover / Form C)
- X3** – TIs: Standard phase current measuring card and sensitive ground current measuring
- X4** – TU: Card with 4 voltage transformer measuring inputs (0 ... 800 VAC, under UL: 0 ... 600 VAC)
- X5** – OR6: Assembly Group with 6 Output Relays (Changeover / Form C)
- X6** – DI8: Assembly Group with 8 Digital Inputs
- X104** – IRIG-B00X, incl. System Contact (Supervision Contact)

MRA4-2D1AAB

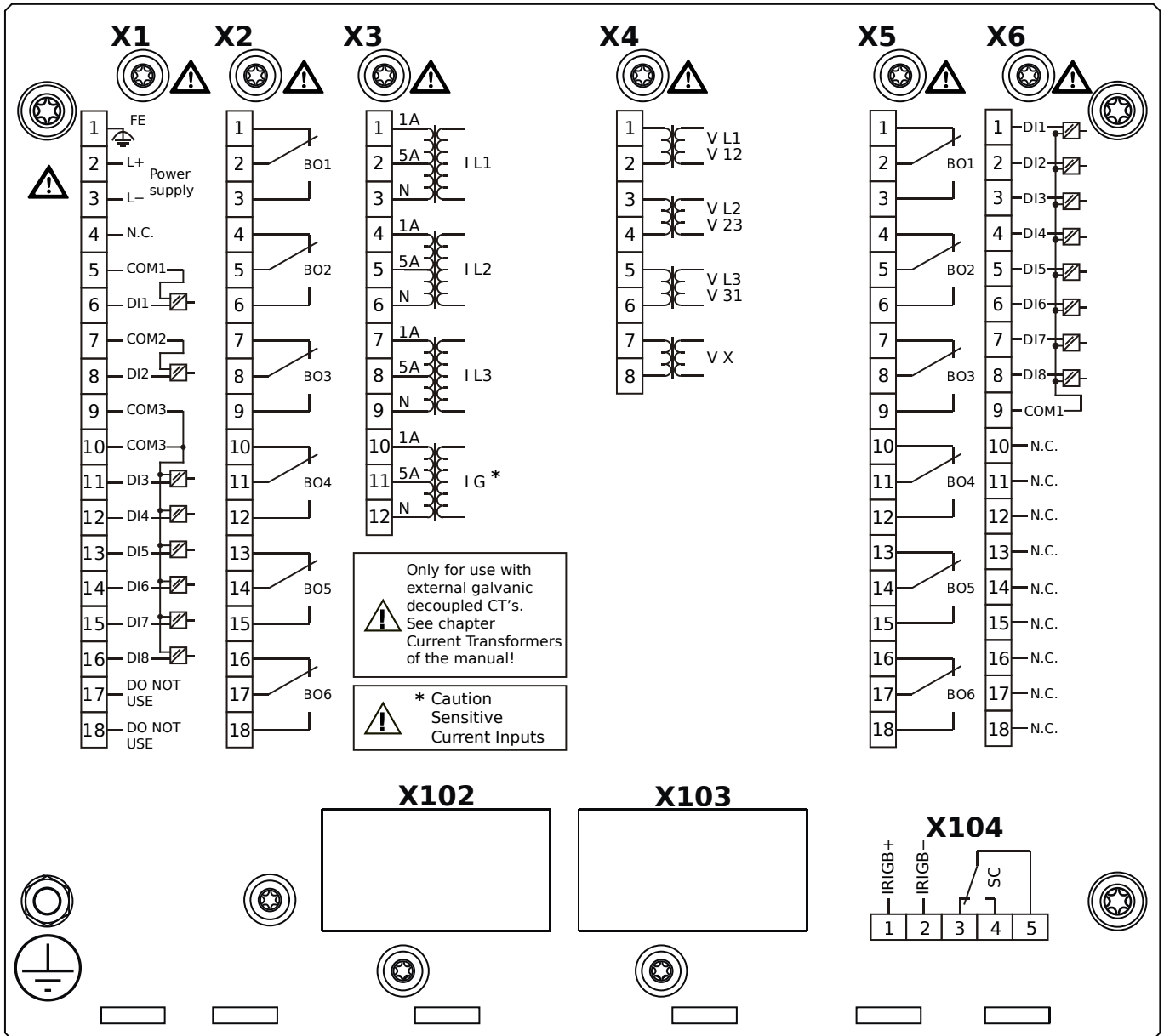

Housing B2, small display, door mounting

+ Conformal Coating (for installations in harsh environment)

- X1** – DI8-X1: Wide-range power supply unit, incl. 2 non-grouped digital inputs and 6 grouped digital inputs
- X2** – OR6: Assembly Group with 6 Output Relays (Changeover / Form C)
- X3** – TIs: Standard phase current measuring card and sensitive ground current measuring
- X4** – TU: Card with 4 voltage transformer measuring inputs (0 ... 800 VAC, under UL: 0 ... 600 VAC)
- X5** – OR6: Assembly Group with 6 Output Relays (Changeover / Form C)
- X6** – DI8: Assembly Group with 8 Digital Inputs
- X104** – IRIG-B00X, incl. System Contact (Supervision Contact)

MRA4-2D1ABA

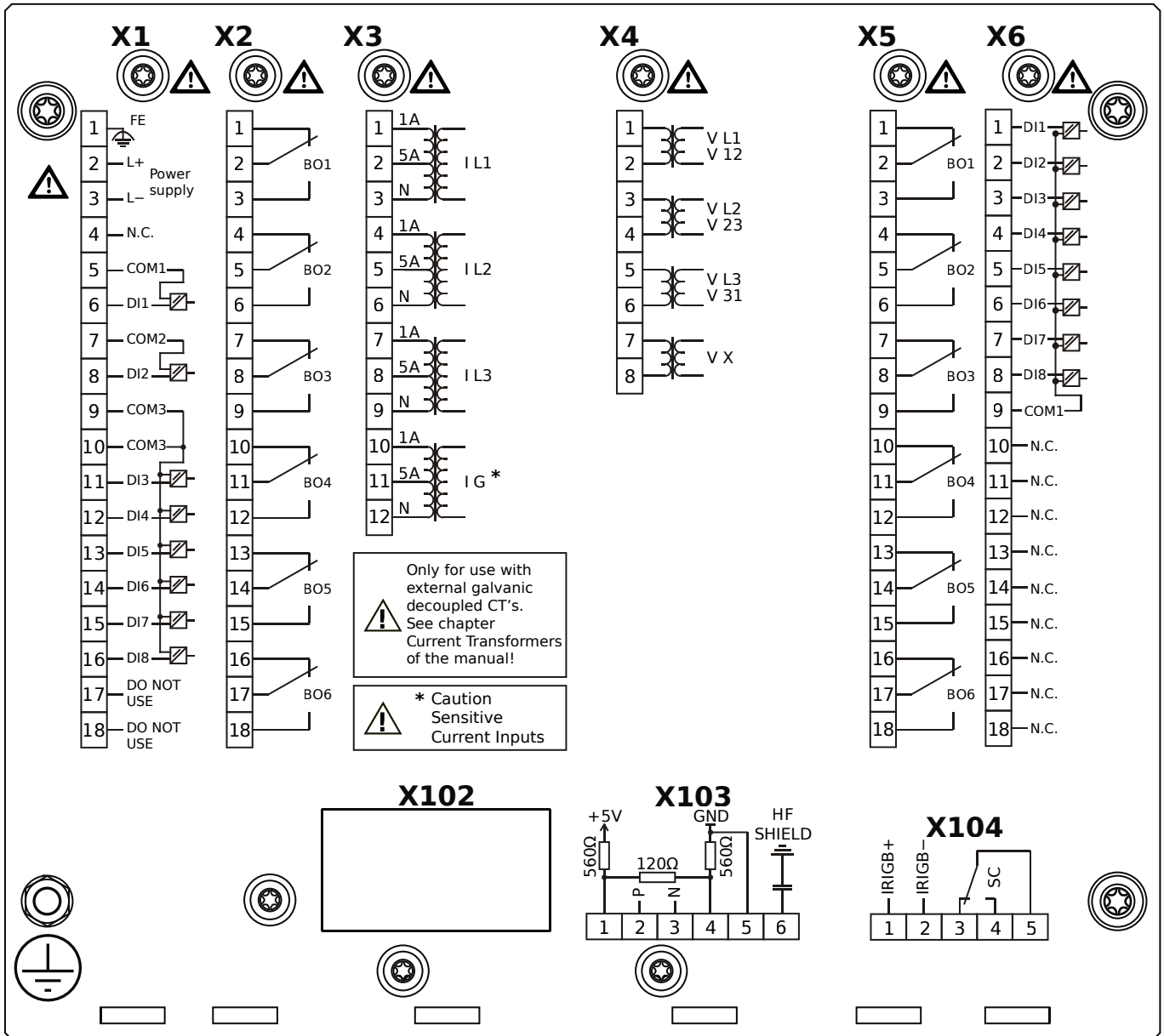

Housing B2, small display, door mounting

- X1** – DI8-X1: Wide-range power supply unit, incl. 2 non-grouped digital inputs and 6 grouped digital inputs
- X2** – OR6: Assembly Group with 6 Output Relays (Changeover / Form C)
- X3** – TIs: Standard phase current measuring card and sensitive ground current measuring
- X4** – TU: Card with 4 voltage transformer measuring inputs (0 ... 800 VAC, under UL: 0 ... 600 VAC)
- X5** – OR6: Assembly Group with 6 Output Relays (Changeover / Form C)
- X6** – DI8: Assembly Group with 8 Digital Inputs
- X103** – Modbus RTU / IEC 60870-5-103 / DNP3.0 RTU, RS485, Terminals
- X104** – IRIG-B00X, incl. System Contact (Supervision Contact)

MRA4-2D1ABB

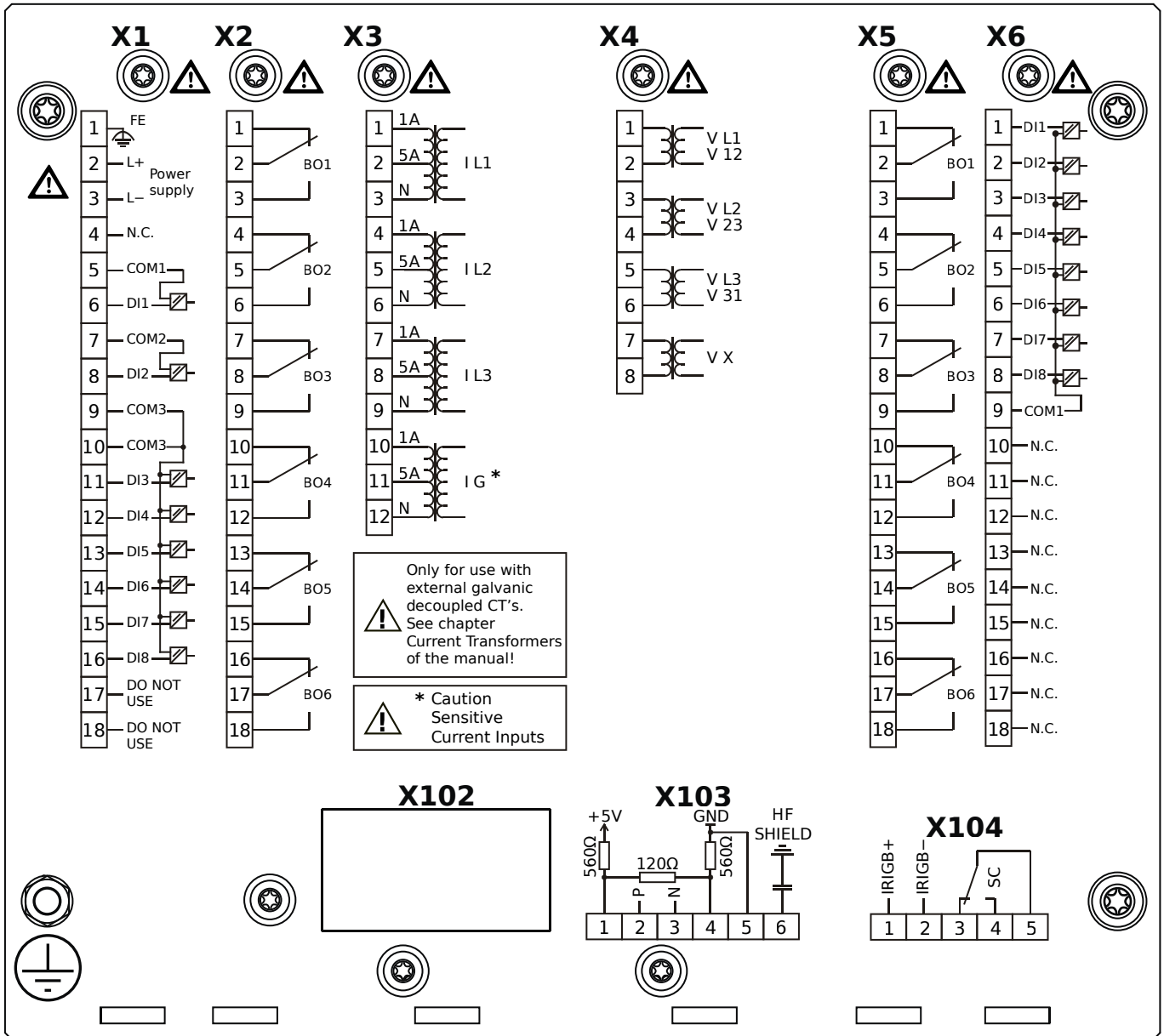

Housing B2, small display, door mounting

+ Conformal Coating (for installations in harsh environment)

- X1** – DI8-X1: Wide-range power supply unit, incl. 2 non-grouped digital inputs and 6 grouped digital inputs
- X2** – OR6: Assembly Group with 6 Output Relays (Changeover / Form C)
- X3** – TIs: Standard phase current measuring card and sensitive ground current measuring
- X4** – TU: Card with 4 voltage transformer measuring inputs (0 ... 800 VAC, under UL: 0 ... 600 VAC)
- X5** – OR6: Assembly Group with 6 Output Relays (Changeover / Form C)
- X6** – DI8: Assembly Group with 8 Digital Inputs
- X103** – Modbus RTU / IEC 60870-5-103 / DNP3.0 RTU, RS485, Terminals
- X104** – IRIG-B00X, incl. System Contact (Supervision Contact)

MRA4-2D1ACA

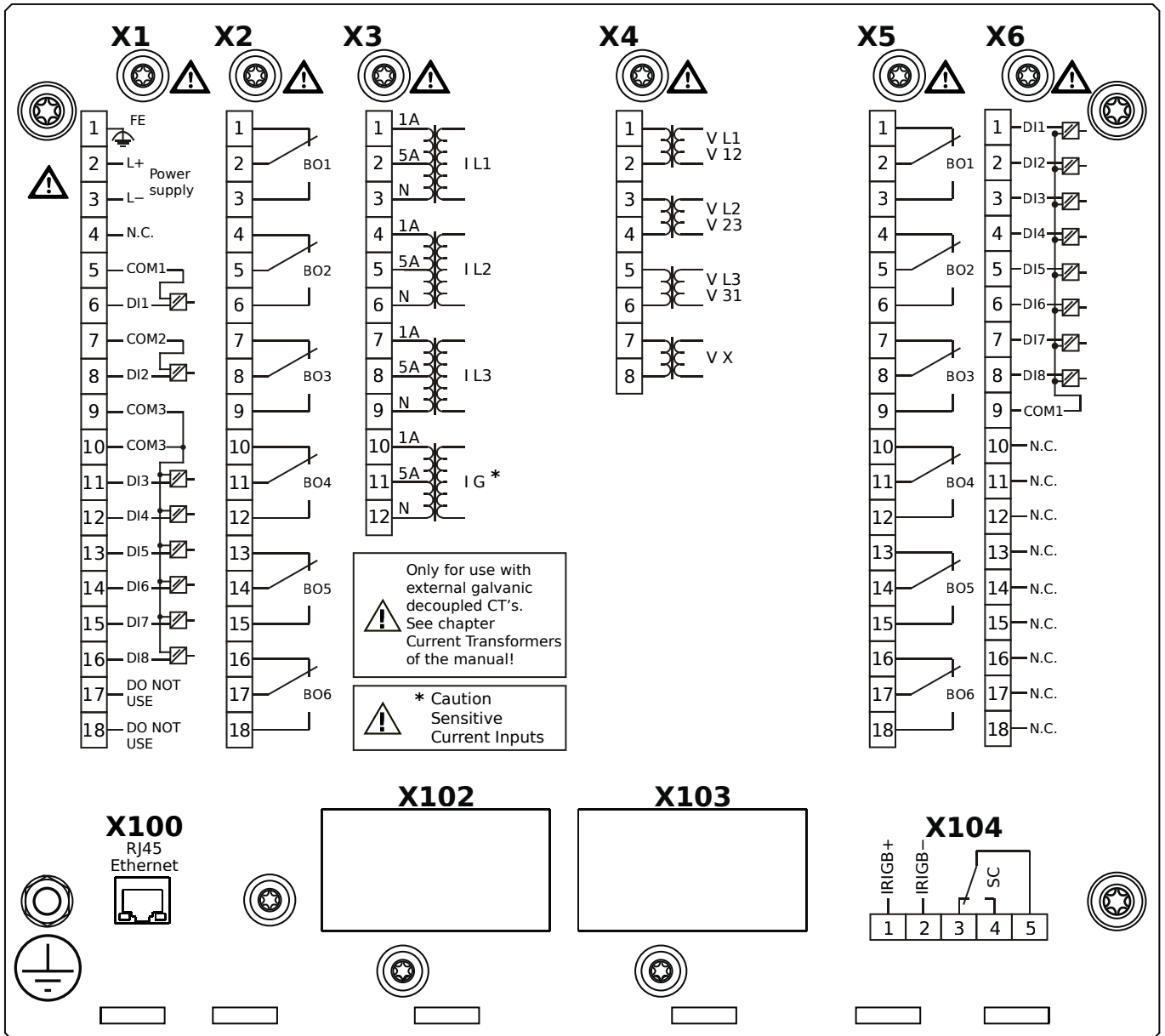

Housing B2, small display, door mounting

- X1** – DI8-X1: Wide-range power supply unit, incl. 2 non-grouped digital inputs and 6 grouped digital inputs
- X2** – OR6: Assembly Group with 6 Output Relays (Changeover / Form C)
- X3** – TIs: Standard phase current measuring card and sensitive ground current measuring
- X4** – TU: Card with 4 voltage transformer measuring inputs (0 ... 800 VAC, under UL: 0 ... 600 VAC)
- X5** – OR6: Assembly Group with 6 Output Relays (Changeover / Form C)
- X6** – DI8: Assembly Group with 8 Digital Inputs
- X100** – Modbus TCP / DNP3.0 TCP/UDP, Ethernet interface, 100 Mbit/s, RJ45 (BASE100-FX)
- X104** – IRIG-B00X, incl. System Contact (Supervision Contact)

MRA4-2D1ACB

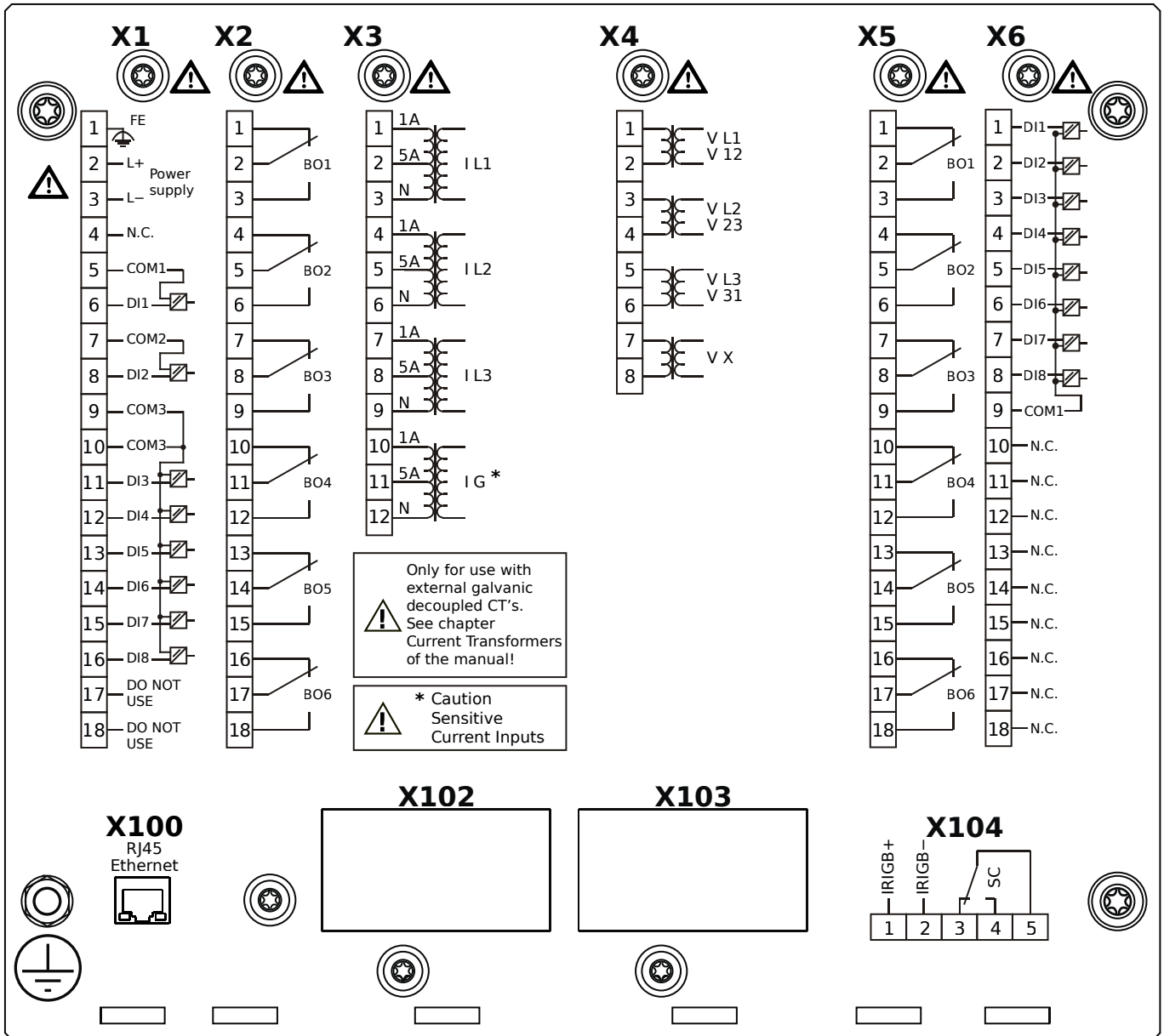

Housing B2, small display, door mounting

+ Conformal Coating (for installations in harsh environment)

- X1** – DI8-X1: Wide-range power supply unit, incl. 2 non-grouped digital inputs and 6 grouped digital inputs
- X2** – OR6: Assembly Group with 6 Output Relays (Changeover / Form C)
- X3** – TIs: Standard phase current measuring card and sensitive ground current measuring
- X4** – TU: Card with 4 voltage transformer measuring inputs (0 ... 800 VAC, under UL: 0 ... 600 VAC)
- X5** – OR6: Assembly Group with 6 Output Relays (Changeover / Form C)
- X6** – DI8: Assembly Group with 8 Digital Inputs
- X100** – Modbus TCP / DNP3.0 TCP/UDP, Ethernet interface, 100 Mbit/s, RJ45 (BASE100-FX)
- X104** – IRIG-B00X, incl. System Contact (Supervision Contact)

MRA4-2D1ADA

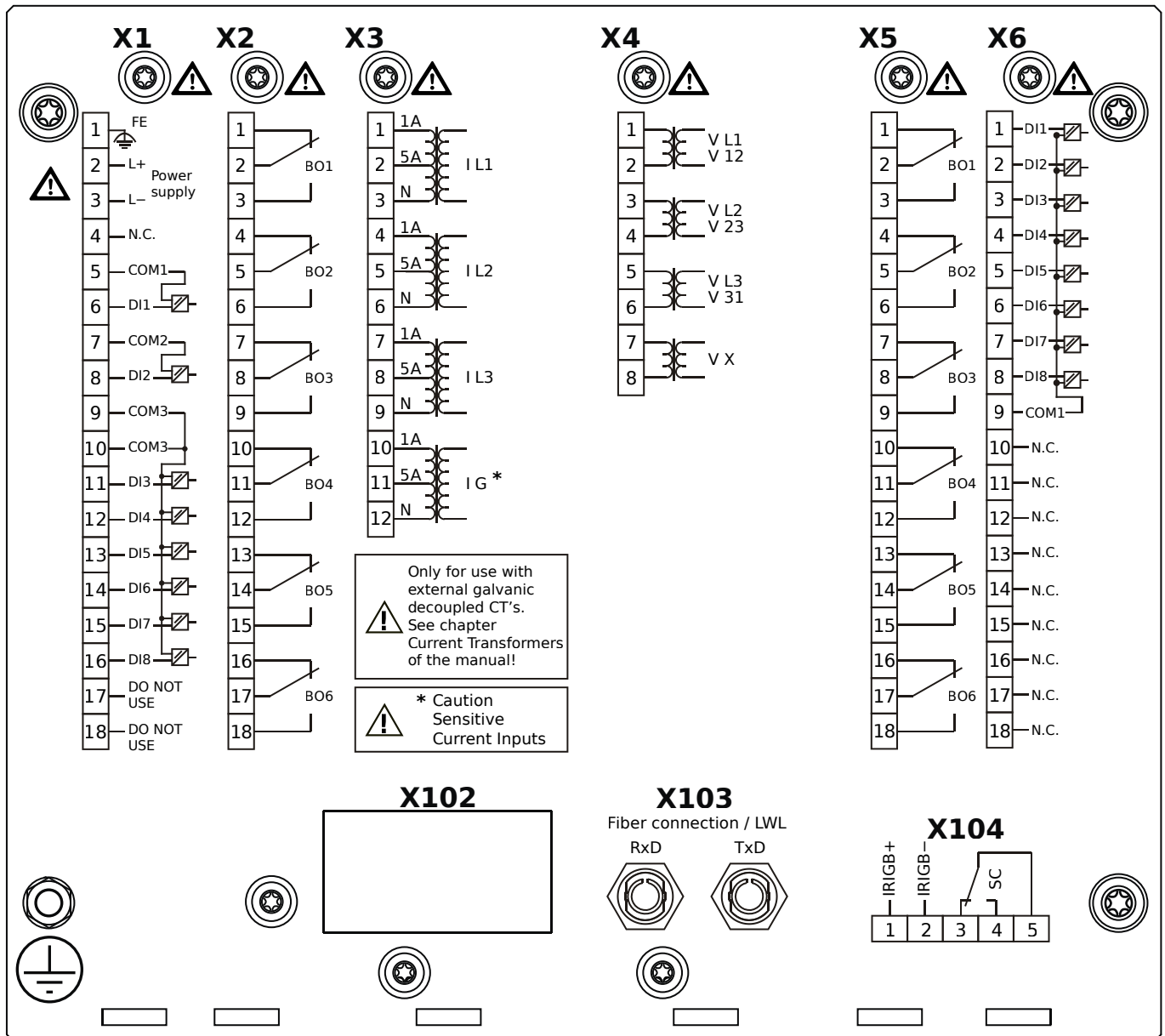

Housing B2, small display, door mounting

- X1** – DI8-X1: Wide-range power supply unit, incl. 2 non-grouped digital inputs and 6 grouped digital inputs
- X2** – OR6: Assembly Group with 6 Output Relays (Changeover / Form C)
- X3** – TIs: Standard phase current measuring card and sensitive ground current measuring
- X4** – TU: Card with 4 voltage transformer measuring inputs (0 ... 800 VAC, under UL: 0 ... 600 VAC)
- X5** – OR6: Assembly Group with 6 Output Relays (Changeover / Form C)
- X6** – DI8: Assembly Group with 8 Digital Inputs
- X103** – Profibus-DP, Fiber optics interface, ST Connector
- X104** – IRIG-B00X, incl. System Contact (Supervision Contact)

MRA4-2D1ADB

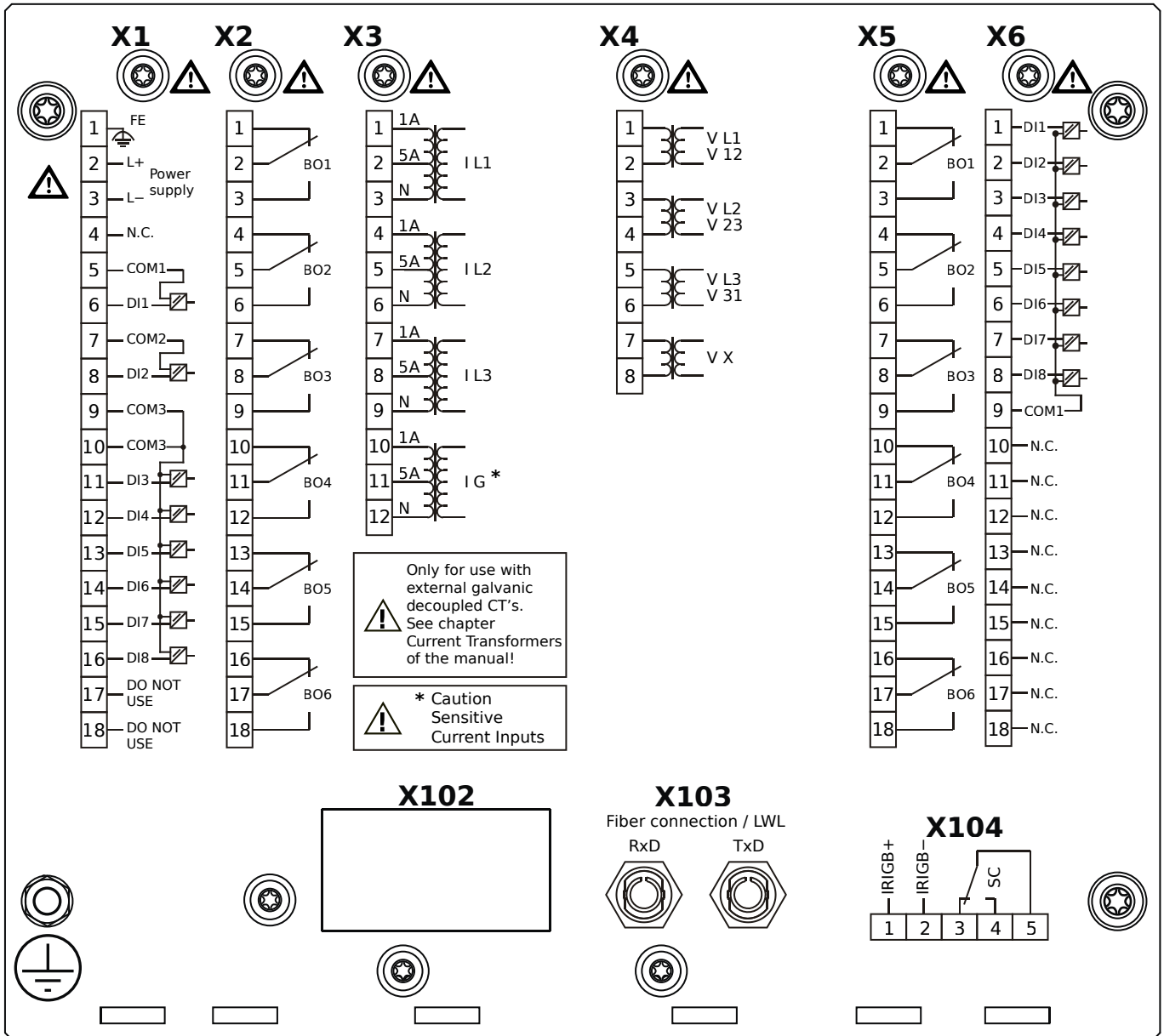

Housing B2, small display, door mounting

+ Conformal Coating (for installations in harsh environment)

- X1** – DI8-X1: Wide-range power supply unit, incl. 2 non-grouped digital inputs and 6 grouped digital inputs
- X2** – OR6: Assembly Group with 6 Output Relays (Changeover / Form C)
- X3** – TIs: Standard phase current measuring card and sensitive ground current measuring
- X4** – TU: Card with 4 voltage transformer measuring inputs (0 ... 800 VAC, under UL: 0 ... 600 VAC)
- X5** – OR6: Assembly Group with 6 Output Relays (Changeover / Form C)
- X6** – DI8: Assembly Group with 8 Digital Inputs
- X103** – Profibus-DP, Fiber optics interface, ST Connector
- X104** – IRIG-B00X, incl. System Contact (Supervision Contact)

MRA4-2D1AEA

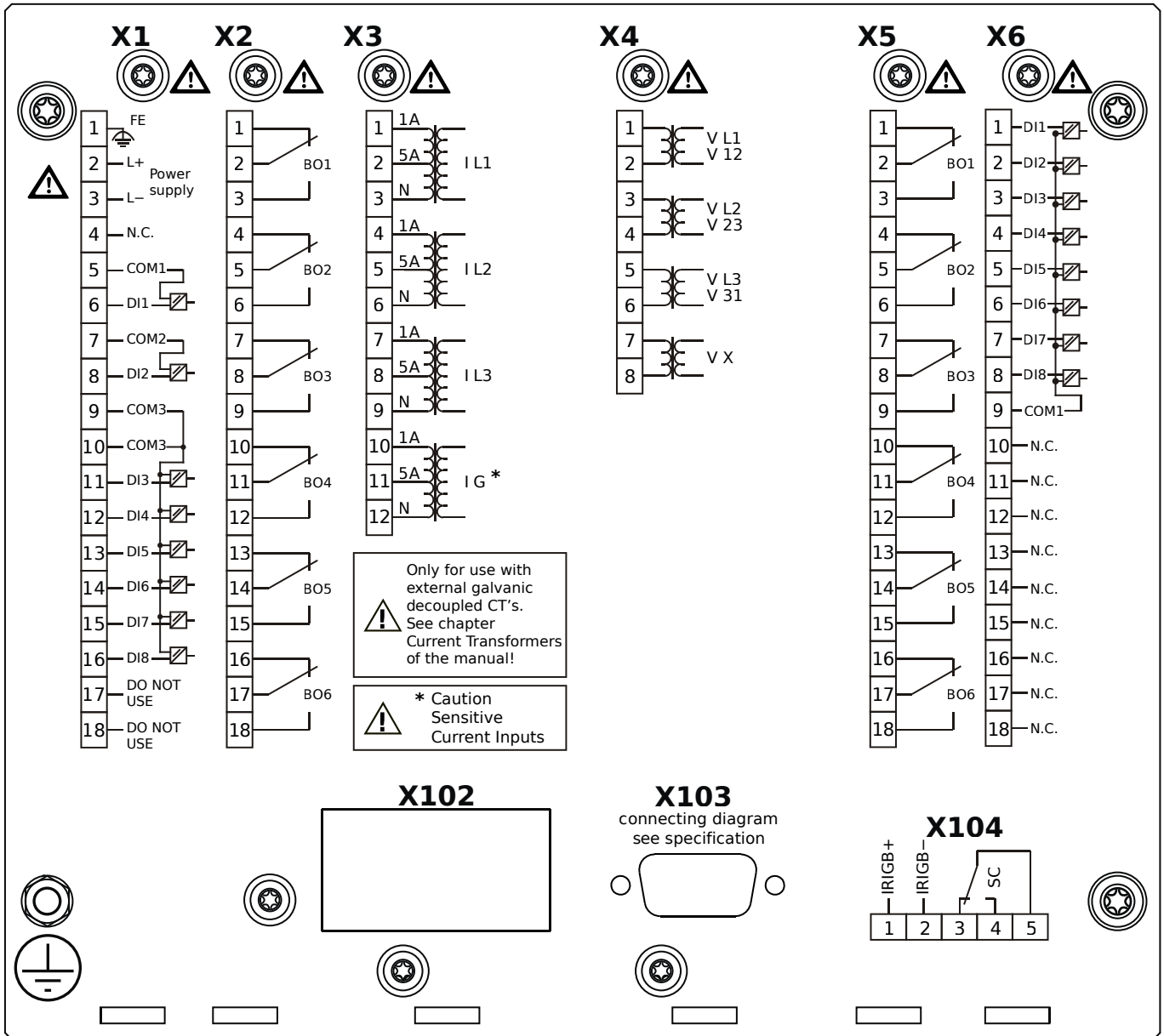

Housing B2, small display, door mounting

- X1** – DI8-X1: Wide-range power supply unit, incl. 2 non-grouped digital inputs and 6 grouped digital inputs
- X2** – OR6: Assembly Group with 6 Output Relays (Changeover / Form C)
- X3** – TIs: Standard phase current measuring card and sensitive ground current measuring
- X4** – TU: Card with 4 voltage transformer measuring inputs (0 ... 800 VAC, under UL: 0 ... 600 VAC)
- X5** – OR6: Assembly Group with 6 Output Relays (Changeover / Form C)
- X6** – DI8: Assembly Group with 8 Digital Inputs
- X103** – Profibus-DP, RS485, D-SUB
- X104** – IRIG-B00X, incl. System Contact (Supervision Contact)

MRA4-2D1AEB

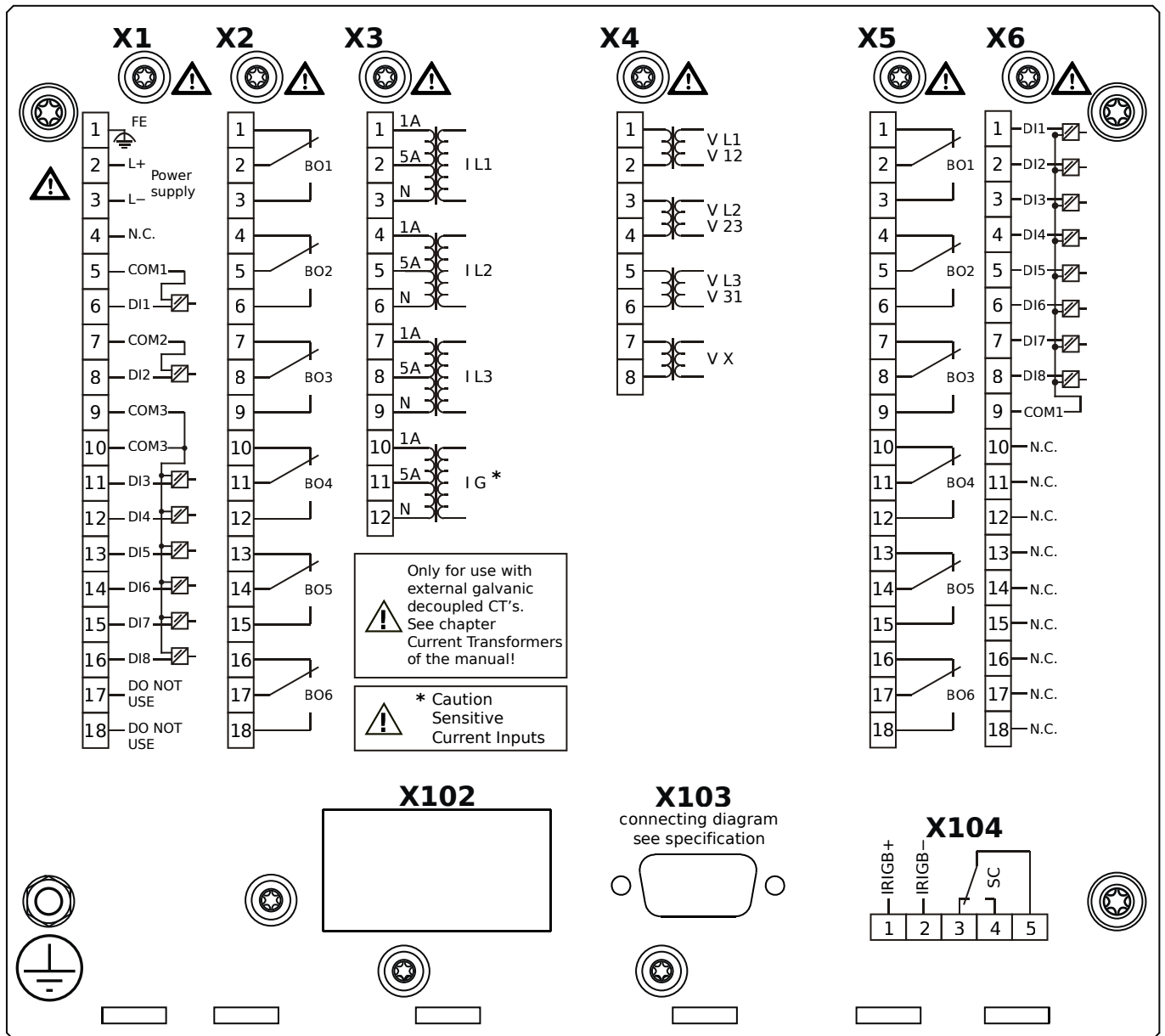

Housing B2, small display, door mounting

+ Conformal Coating (for installations in harsh environment)

- X1** – DI8-X1: Wide-range power supply unit, incl. 2 non-grouped digital inputs and 6 grouped digital inputs
- X2** – OR6: Assembly Group with 6 Output Relays (Changeover / Form C)
- X3** – TIs: Standard phase current measuring card and sensitive ground current measuring
- X4** – TU: Card with 4 voltage transformer measuring inputs (0 ... 800 VAC, under UL: 0 ... 600 VAC)
- X5** – OR6: Assembly Group with 6 Output Relays (Changeover / Form C)
- X6** – DI8: Assembly Group with 8 Digital Inputs
- X103** – Profibus-DP, RS485, D-SUB
- X104** – IRIG-B00X, incl. System Contact (Supervision Contact)

MRA4-2D1AFA

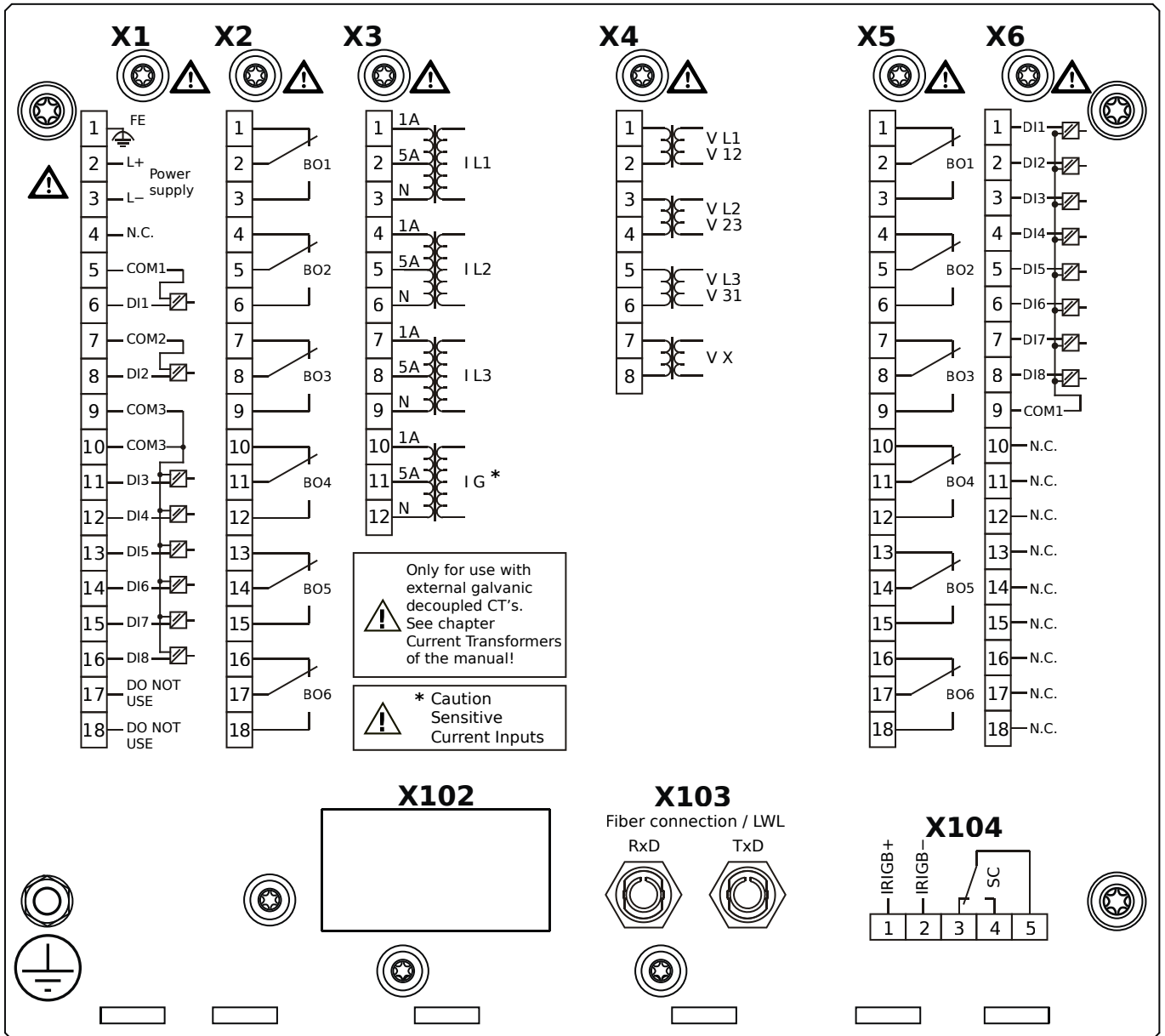

Housing B2, small display, door mounting

- X1** – DI8-X1: Wide-range power supply unit, incl. 2 non-grouped digital inputs and 6 grouped digital inputs
- X2** – OR6: Assembly Group with 6 Output Relays (Changeover / Form C)
- X3** – TIs: Standard phase current measuring card and sensitive ground current measuring
- X4** – TU: Card with 4 voltage transformer measuring inputs (0 ... 800 VAC, under UL: 0 ... 600 VAC)
- X5** – OR6: Assembly Group with 6 Output Relays (Changeover / Form C)
- X6** – DI8: Assembly Group with 8 Digital Inputs
- X103** – Modbus RTU / IEC 60870-5-103 / DNP3.0 RTU, Fiber optics interface, ST Connector
- X104** – IRIG-B00X, incl. System Contact (Supervision Contact)

MRA4-2D1AFB

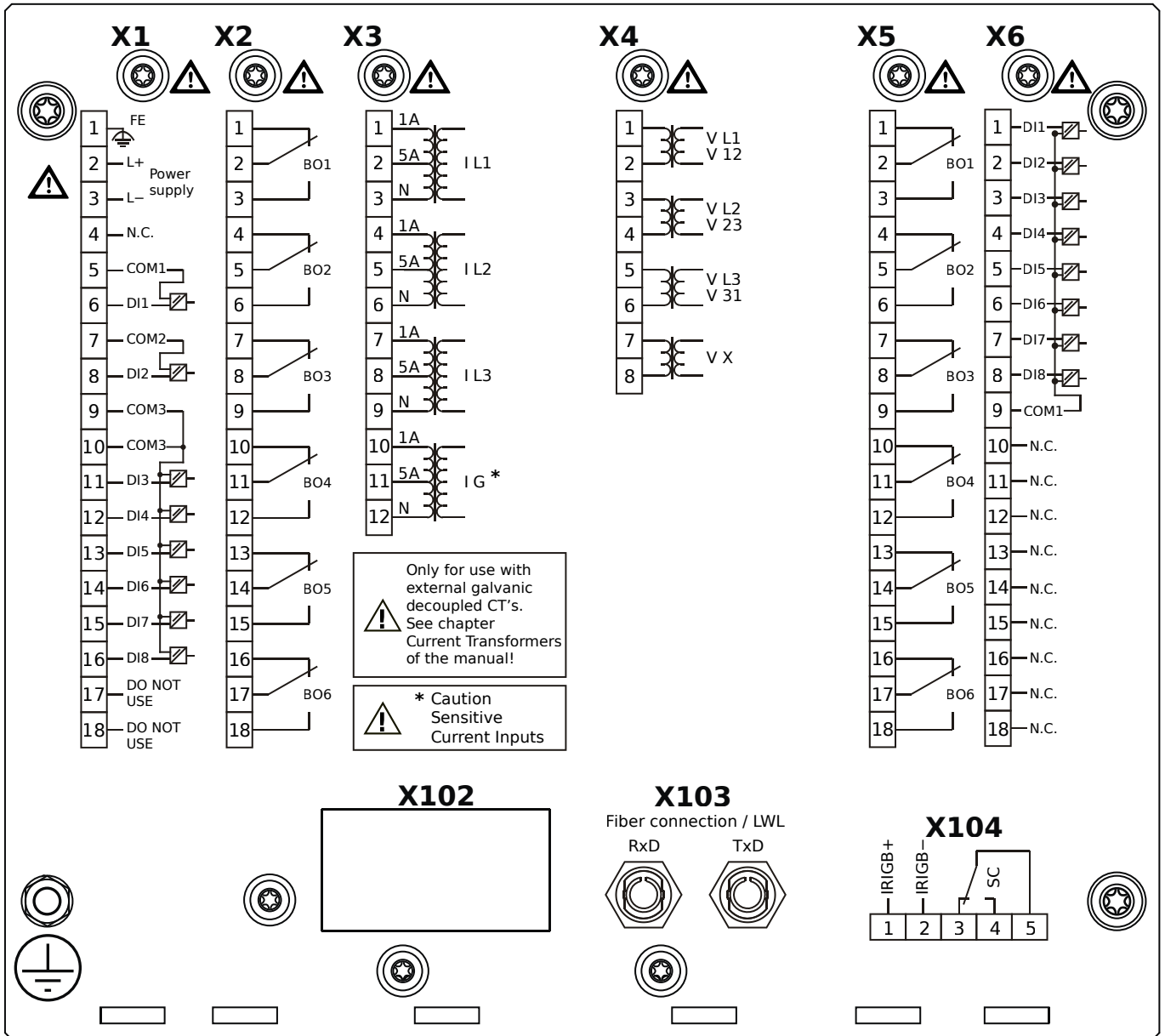

Housing B2, small display, door mounting

+ Conformal Coating (for installations in harsh environment)

- X1** – DI8-X1: Wide-range power supply unit, incl. 2 non-grouped digital inputs and 6 grouped digital inputs
- X2** – OR6: Assembly Group with 6 Output Relays (Changeover / Form C)
- X3** – TIs: Standard phase current measuring card and sensitive ground current measuring
- X4** – TU: Card with 4 voltage transformer measuring inputs (0 ... 800 VAC, under UL: 0 ... 600 VAC)
- X5** – OR6: Assembly Group with 6 Output Relays (Changeover / Form C)
- X6** – DI8: Assembly Group with 8 Digital Inputs
- X103** – Modbus RTU / IEC 60870-5-103 / DNP3.0 RTU, Fiber optics interface, ST Connector
- X104** – IRIG-B00X, incl. System Contact (Supervision Contact)

MRA4-2D1AGA

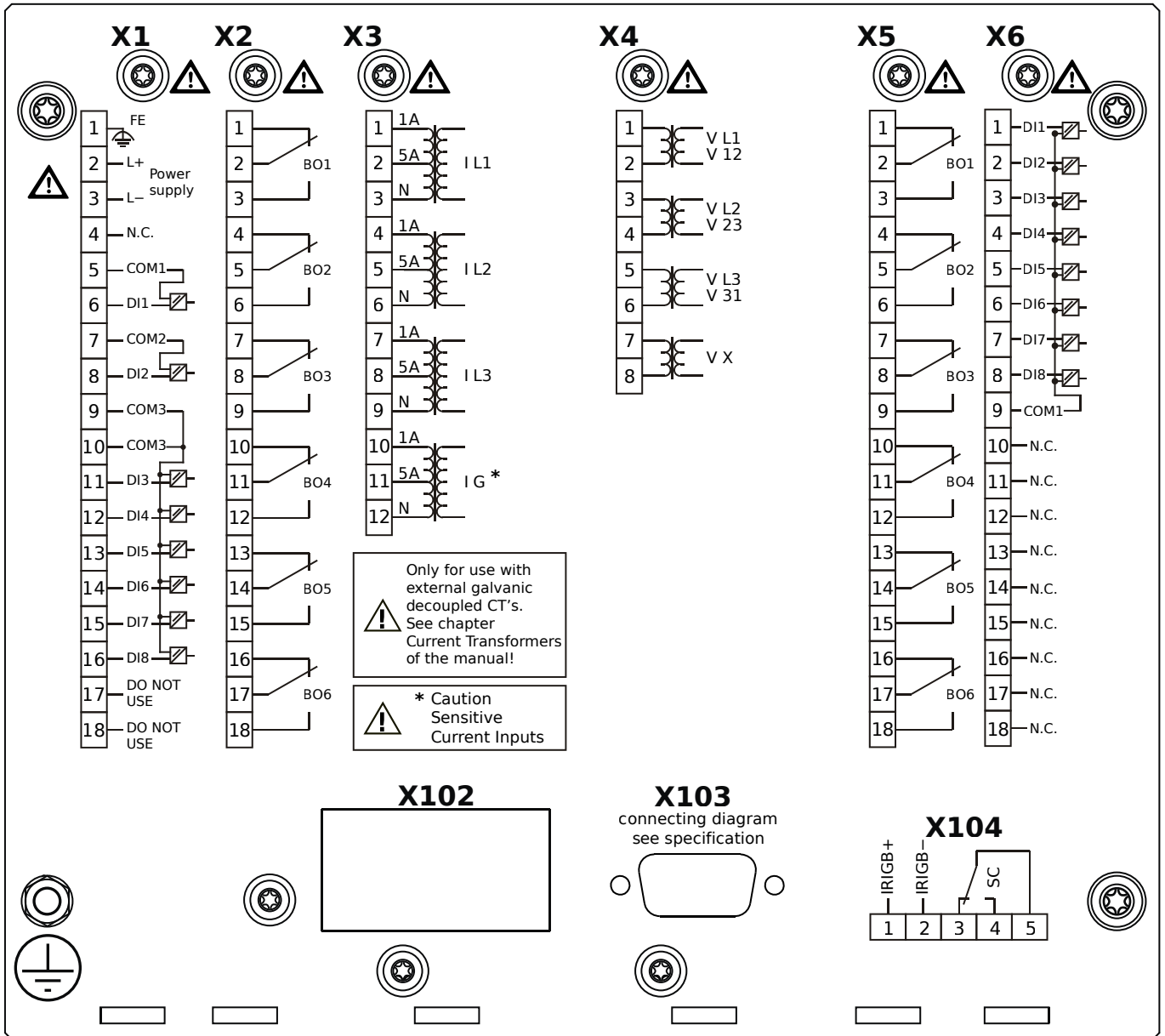

Housing B2, small display, door mounting

- X1** – DI8-X1: Wide-range power supply unit, incl. 2 non-grouped digital inputs and 6 grouped digital inputs
- X2** – OR6: Assembly Group with 6 Output Relays (Changeover / Form C)
- X3** – TIs: Standard phase current measuring card and sensitive ground current measuring
- X4** – TU: Card with 4 voltage transformer measuring inputs (0 ... 800 VAC, under UL: 0 ... 600 VAC)
- X5** – OR6: Assembly Group with 6 Output Relays (Changeover / Form C)
- X6** – DI8: Assembly Group with 8 Digital Inputs
- X103** – Modbus RTU / IEC 60870-5-103 / DNP3.0 RTU, RS485, D-SUB
- X104** – IRIG-B00X, incl. System Contact (Supervision Contact)

MRA4-2D1AGB

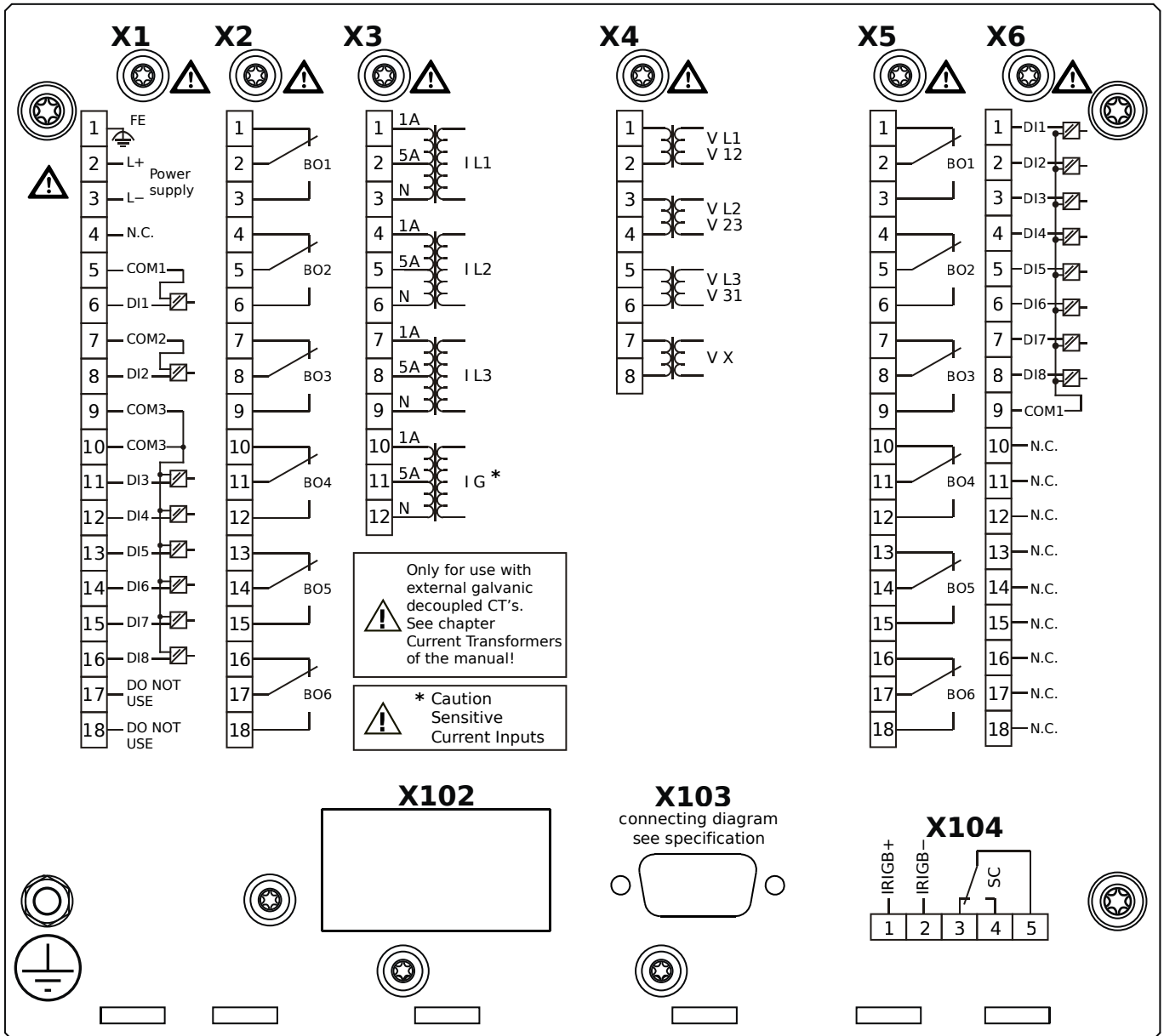

Housing B2, small display, door mounting

+ Conformal Coating (for installations in harsh environment)

- X1** – DI8-X1: Wide-range power supply unit, incl. 2 non-grouped digital inputs and 6 grouped digital inputs
- X2** – OR6: Assembly Group with 6 Output Relays (Changeover / Form C)
- X3** – TIs: Standard phase current measuring card and sensitive ground current measuring
- X4** – TU: Card with 4 voltage transformer measuring inputs (0 ... 800 VAC, under UL: 0 ... 600 VAC)
- X5** – OR6: Assembly Group with 6 Output Relays (Changeover / Form C)
- X6** – DI8: Assembly Group with 8 Digital Inputs
- X103** – Modbus RTU / IEC 60870-5-103 / DNP3.0 RTU, RS485, D-SUB
- X104** – IRIG-B00X, incl. System Contact (Supervision Contact)

MRA4-2D1AHA

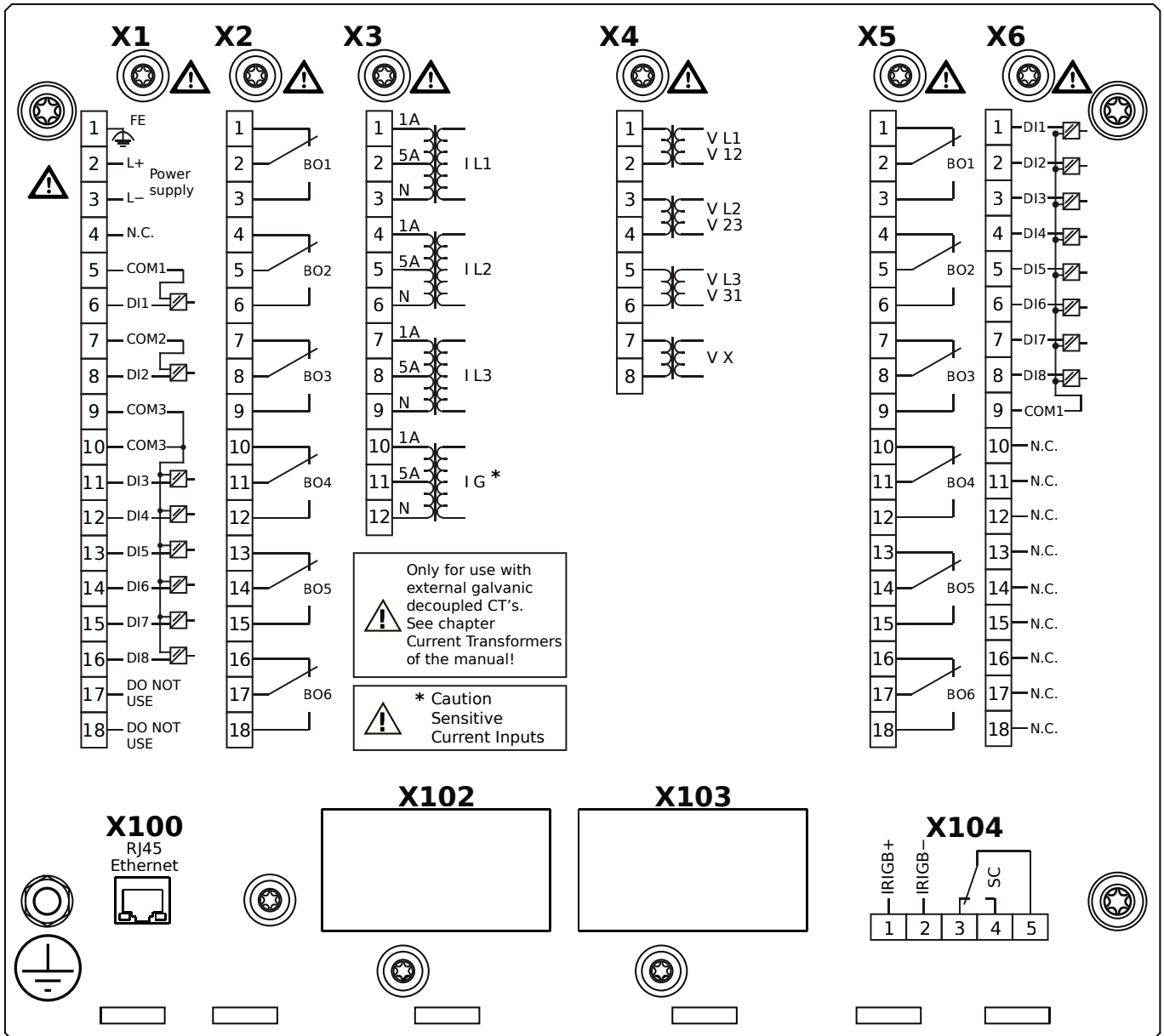

Housing B2, small display, door mounting

- X1** – DI8-X1: Wide-range power supply unit, incl. 2 non-grouped digital inputs and 6 grouped digital inputs
- X2** – OR6: Assembly Group with 6 Output Relays (Changeover / Form C)
- X3** – TIs: Standard phase current measuring card and sensitive ground current measuring
- X4** – TU: Card with 4 voltage transformer measuring inputs (0 ... 800 VAC, under UL: 0 ... 600 VAC)
- X5** – OR6: Assembly Group with 6 Output Relays (Changeover / Form C)
- X6** – DI8: Assembly Group with 8 Digital Inputs
- X100** – IEC 61850 / Modbus TCP / DNP3.0 TCP/UDP, Ethernet interface, 100 Mbit/s, RJ45 (BASE100-FX)
- X104** – IRIG-B00X, incl. System Contact (Supervision Contact)

MRA4-2D1AHB

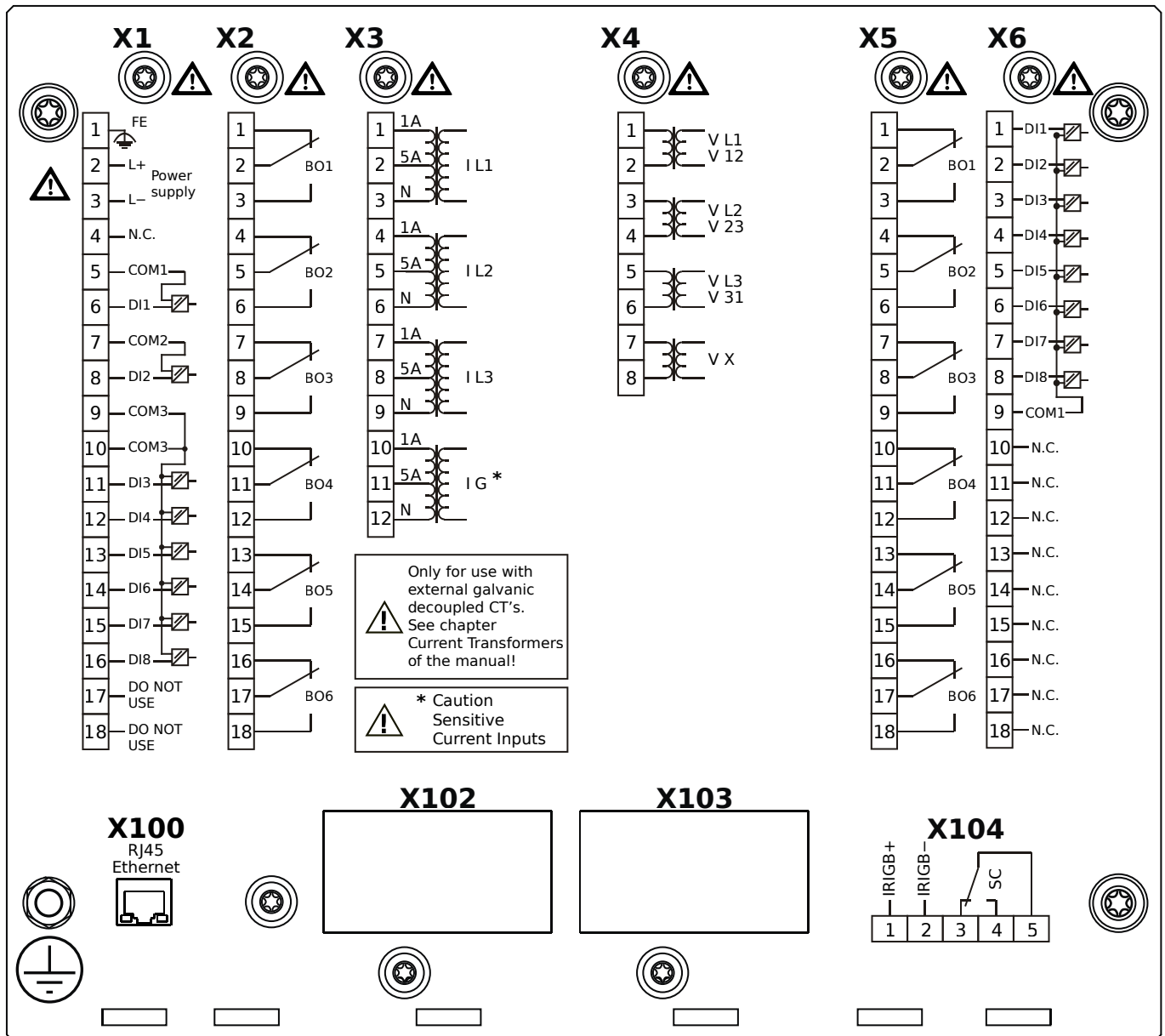

Housing B2, small display, door mounting

+ Conformal Coating (for installations in harsh environment)

- X1** – DI8-X1: Wide-range power supply unit, incl. 2 non-grouped digital inputs and 6 grouped digital inputs
- X2** – OR6: Assembly Group with 6 Output Relays (Changeover / Form C)
- X3** – TIs: Standard phase current measuring card and sensitive ground current measuring
- X4** – TU: Card with 4 voltage transformer measuring inputs (0 ... 800 VAC, under UL: 0 ... 600 VAC)
- X5** – OR6: Assembly Group with 6 Output Relays (Changeover / Form C)
- X6** – DI8: Assembly Group with 8 Digital Inputs
- X100** – IEC 61850 / Modbus TCP / DNP3.0 TCP/UDP, Ethernet interface, 100 Mbit/s, RJ45 (BASE100-FX)
- X104** – IRIG-B00X, incl. System Contact (Supervision Contact)

MRA4-2D1AIA

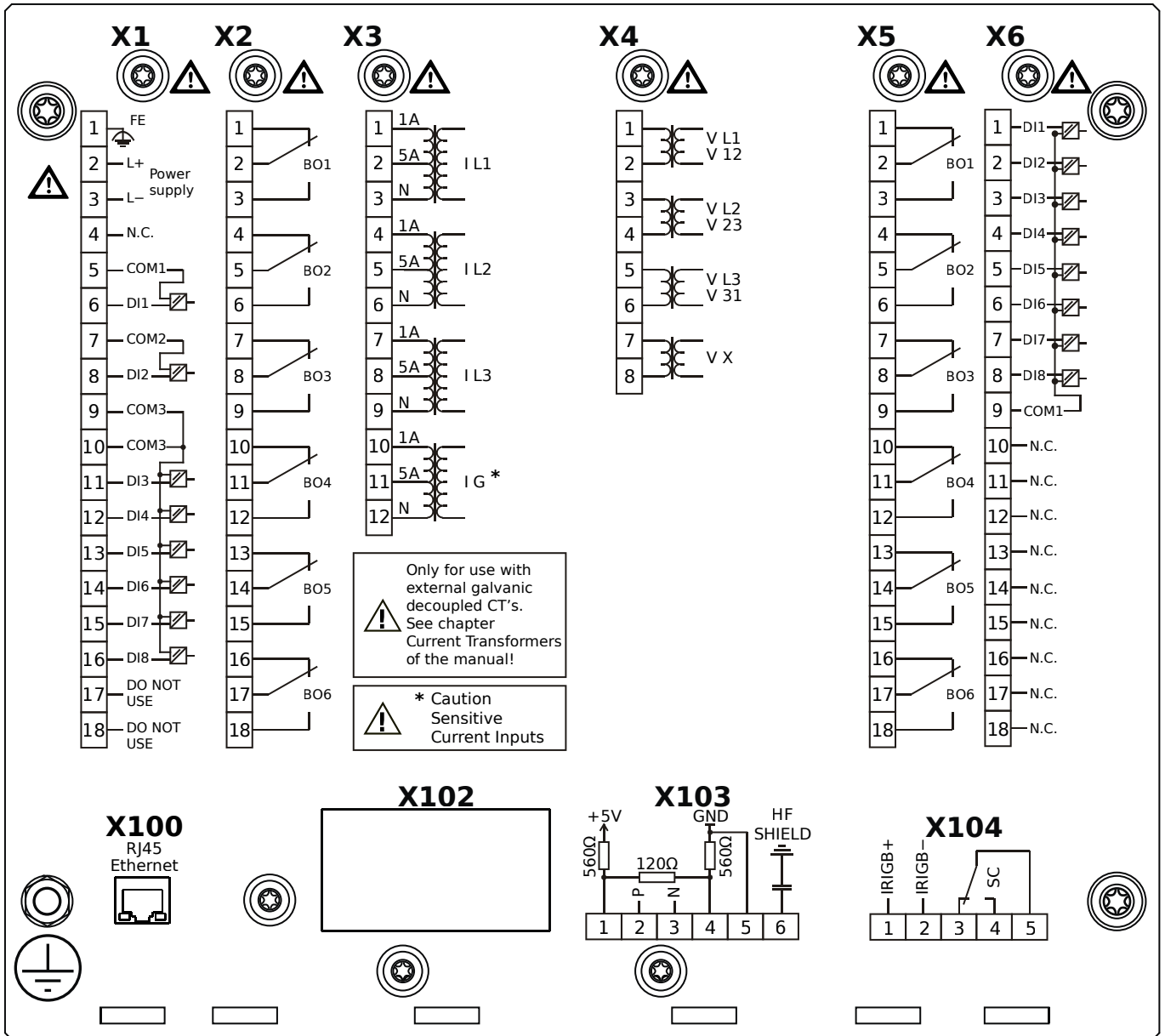

Housing B2, small display, door mounting

- X1** – DI8-X1: Wide-range power supply unit, incl. 2 non-grouped digital inputs and 6 grouped digital inputs
- X2** – OR6: Assembly Group with 6 Output Relays (Changeover / Form C)
- X3** – TIs: Standard phase current measuring card and sensitive ground current measuring
- X4** – TU: Card with 4 voltage transformer measuring inputs (0 ... 800 VAC, under UL: 0 ... 600 VAC)
- X5** – OR6: Assembly Group with 6 Output Relays (Changeover / Form C)
- X6** – DI8: Assembly Group with 8 Digital Inputs
- X100** – Modbus TCP / DNP3.0 TCP/UDP, Ethernet interface, 100 Mbit/s, RJ45 (BASE100-FX)
- X103** – IEC 60870-5-103 / Modbus RTU / DNP3.0 RTU, RS485, Terminals
- X104** – IRIG-B00X, incl. System Contact (Supervision Contact)

MRA4-2D1AIB

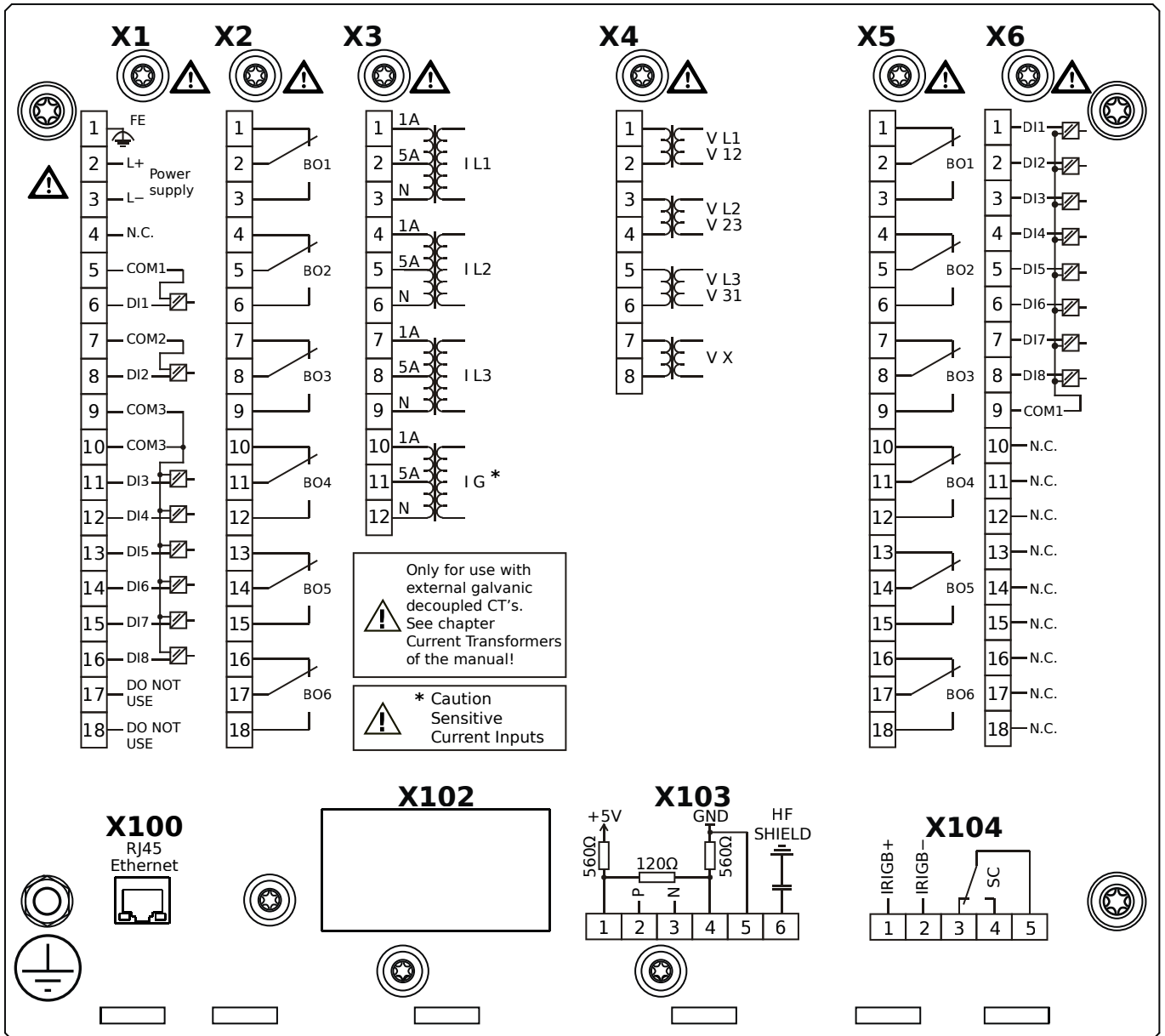

Housing B2, small display, door mounting

+ Conformal Coating (for installations in harsh environment)

- X1** – DI8-X1: Wide-range power supply unit, incl. 2 non-grouped digital inputs and 6 grouped digital inputs
- X2** – OR6: Assembly Group with 6 Output Relays (Changeover / Form C)
- X3** – TIs: Standard phase current measuring card and sensitive ground current measuring
- X4** – TU: Card with 4 voltage transformer measuring inputs (0 ... 800 VAC, under UL: 0 ... 600 VAC)
- X5** – OR6: Assembly Group with 6 Output Relays (Changeover / Form C)
- X6** – DI8: Assembly Group with 8 Digital Inputs
- X100** – Modbus TCP / DNP3.0 TCP/UDP, Ethernet interface, 100 Mbit/s, RJ45 (BASE100-FX)
- X103** – IEC 60870-5-103 / Modbus RTU / DNP3.0 RTU, RS485, Terminals
- X104** – IRIG-B00X, incl. System Contact (Supervision Contact)

MRA4-2D1AKA

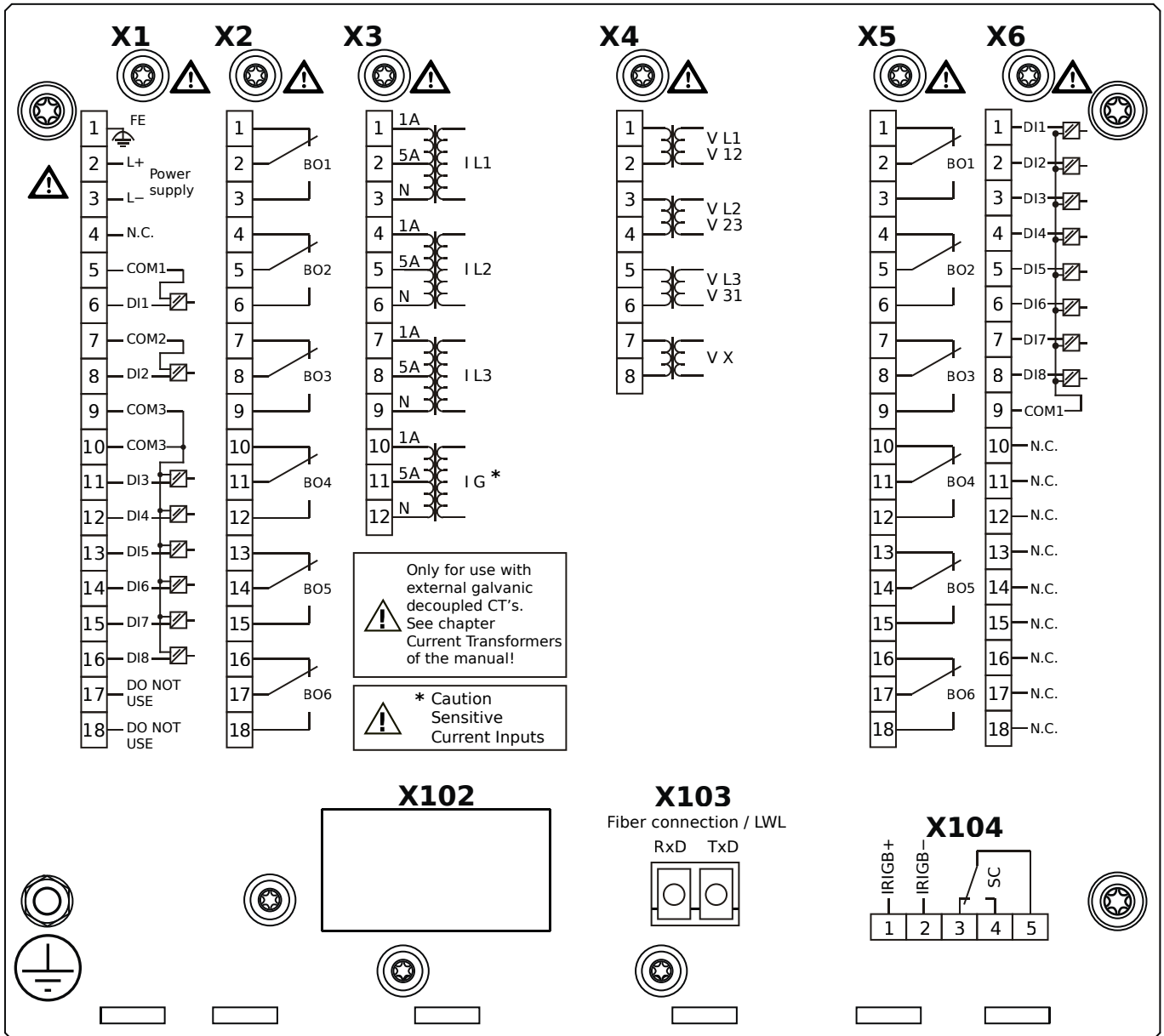

Housing B2, small display, door mounting

- X1** – DI8-X1: Wide-range power supply unit, incl. 2 non-grouped digital inputs and 6 grouped digital inputs
- X2** – OR6: Assembly Group with 6 Output Relays (Changeover / Form C)
- X3** – TIs: Standard phase current measuring card and sensitive ground current measuring
- X4** – TU: Card with 4 voltage transformer measuring inputs (0 ... 800 VAC, under UL: 0 ... 600 VAC)
- X5** – OR6: Assembly Group with 6 Output Relays (Changeover / Form C)
- X6** – DI8: Assembly Group with 8 Digital Inputs
- X103** – IEC 61850 / Modbus TCP / DNP3.0 TCP/UDP, Fiber optics interface, LC Connector
- X104** – IRIG-B00X, incl. System Contact (Supervision Contact)

MRA4-2D1AKB

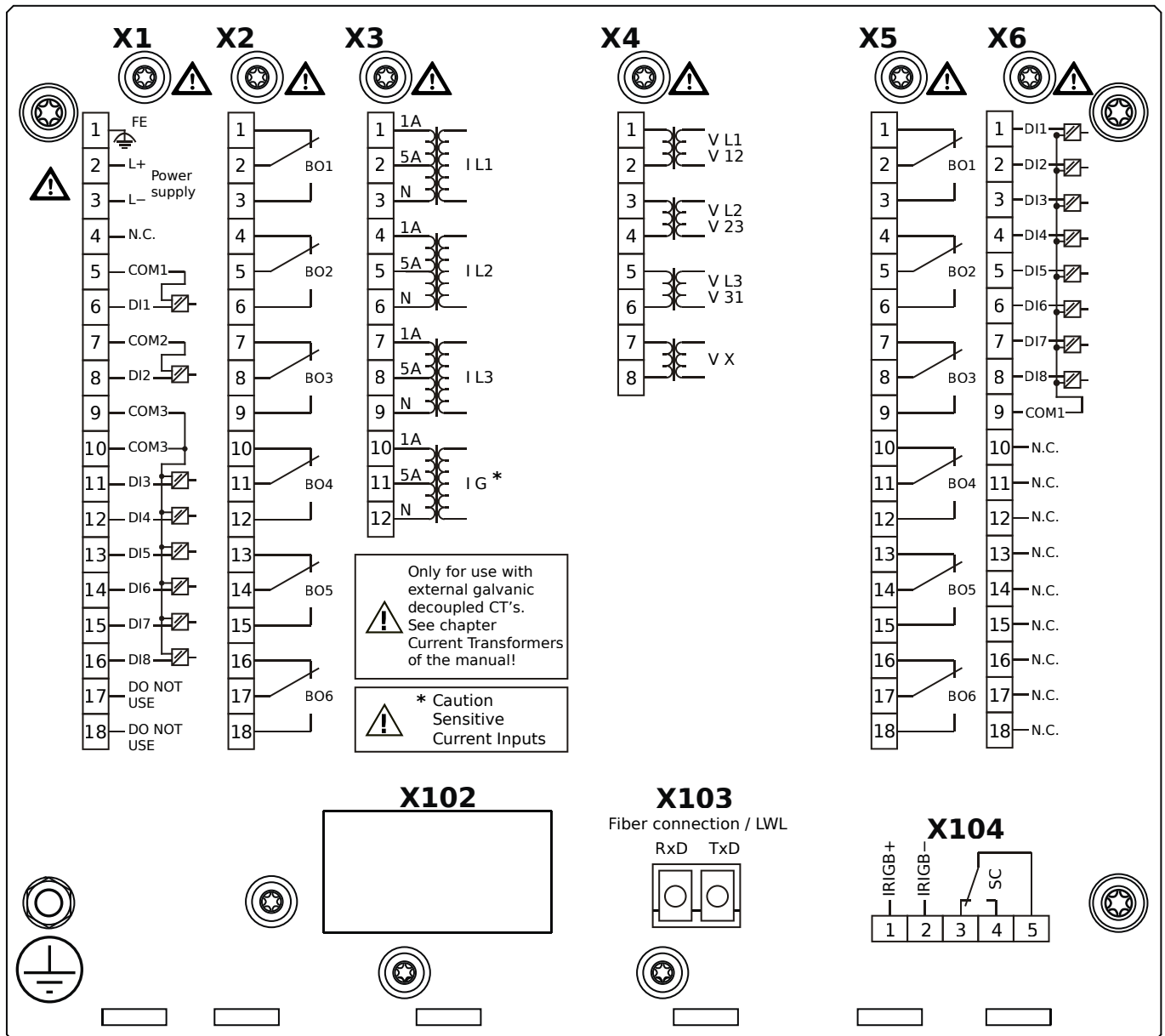

Housing B2, small display, door mounting

+ Conformal Coating (for installations in harsh environment)

- X1** – DI8-X1: Wide-range power supply unit, incl. 2 non-grouped digital inputs and 6 grouped digital inputs
- X2** – OR6: Assembly Group with 6 Output Relays (Changeover / Form C)
- X3** – TIs: Standard phase current measuring card and sensitive ground current measuring
- X4** – TU: Card with 4 voltage transformer measuring inputs (0 ... 800 VAC, under UL: 0 ... 600 VAC)
- X5** – OR6: Assembly Group with 6 Output Relays (Changeover / Form C)
- X6** – DI8: Assembly Group with 8 Digital Inputs
- X103** – IEC 61850 / Modbus TCP / DNP3.0 TCP/UDP, Fiber optics interface, LC Connector
- X104** – IRIG-B00X, incl. System Contact (Supervision Contact)

MRA4-2D1ALA

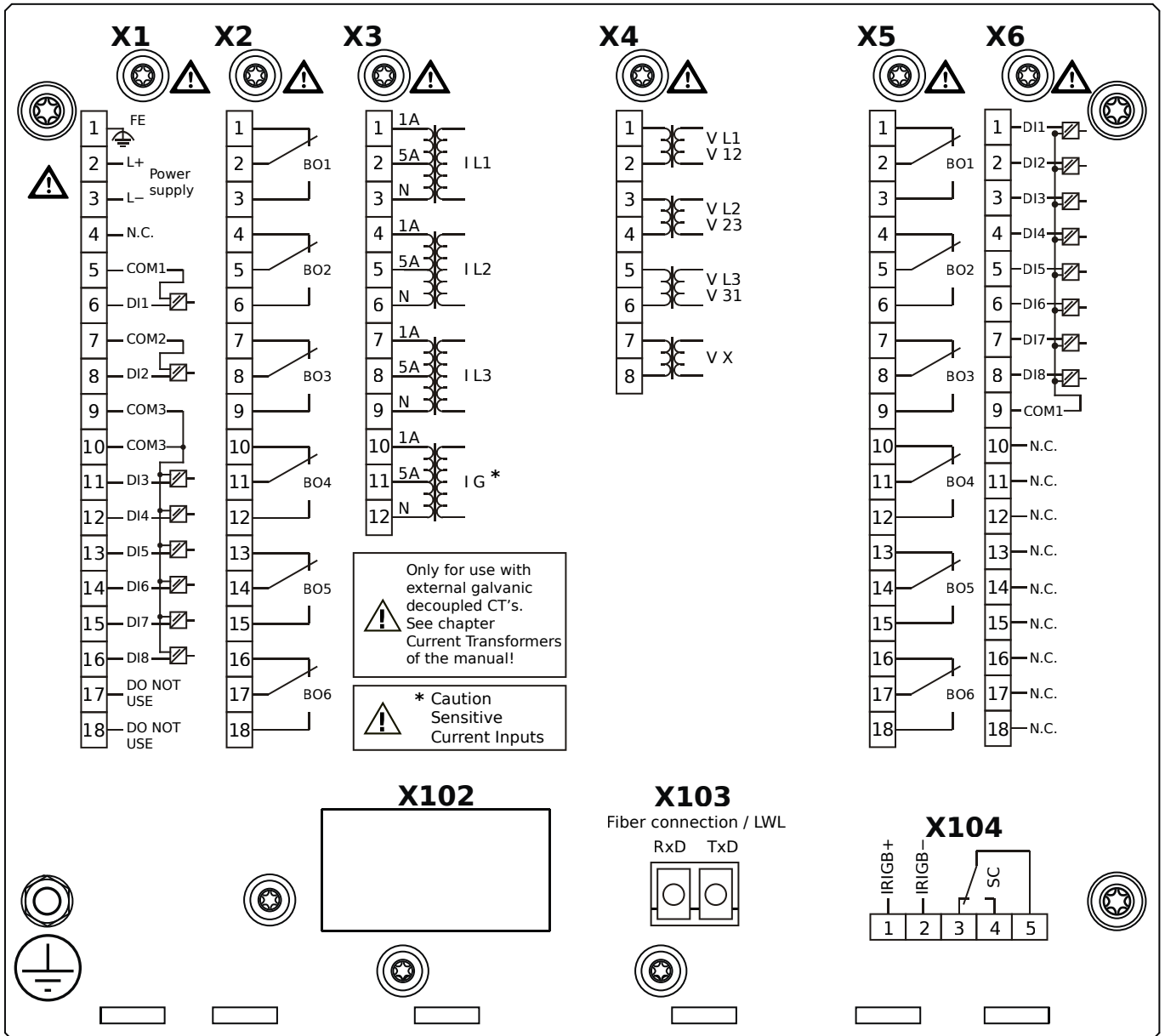

Housing B2, small display, door mounting

- X1** – DI8-X1: Wide-range power supply unit, incl. 2 non-grouped digital inputs and 6 grouped digital inputs
- X2** – OR6: Assembly Group with 6 Output Relays (Changeover / Form C)
- X3** – TIs: Standard phase current measuring card and sensitive ground current measuring
- X4** – TU: Card with 4 voltage transformer measuring inputs (0 ... 800 VAC, under UL: 0 ... 600 VAC)
- X5** – OR6: Assembly Group with 6 Output Relays (Changeover / Form C)
- X6** – DI8: Assembly Group with 8 Digital Inputs
- X103** – Modbus TCP / DNP3.0 TCP/UDP, Fiber optics interface, LC Connector
- X104** – IRIG-B00X, incl. System Contact (Supervision Contact)

MRA4-2D1ALB

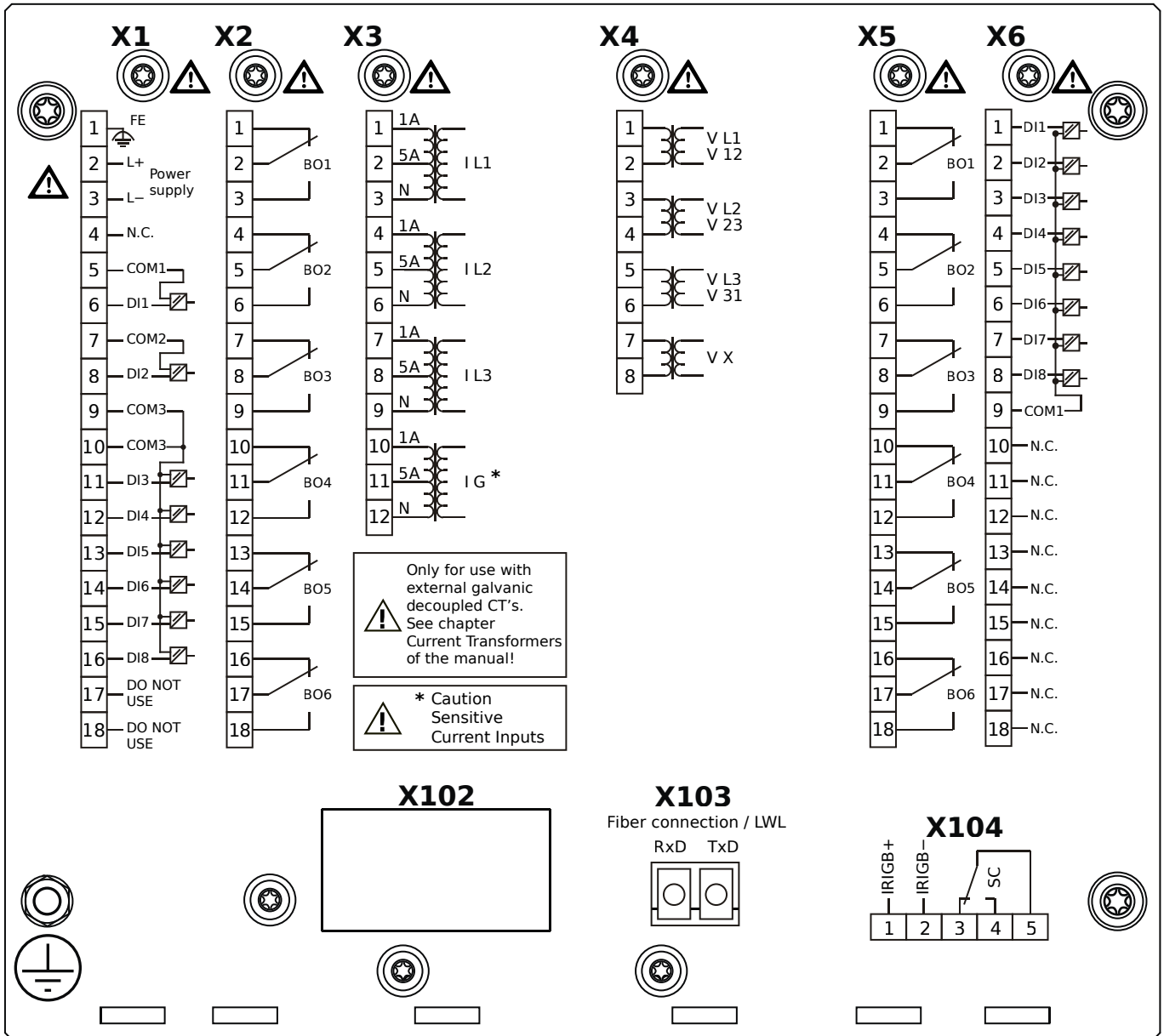

Housing B2, small display, door mounting

+ Conformal Coating (for installations in harsh environment)

- X1** – DI8-X1: Wide-range power supply unit, incl. 2 non-grouped digital inputs and 6 grouped digital inputs
- X2** – OR6: Assembly Group with 6 Output Relays (Changeover / Form C)
- X3** – TIs: Standard phase current measuring card and sensitive ground current measuring
- X4** – TU: Card with 4 voltage transformer measuring inputs (0 ... 800 VAC, under UL: 0 ... 600 VAC)
- X5** – OR6: Assembly Group with 6 Output Relays (Changeover / Form C)
- X6** – DI8: Assembly Group with 8 Digital Inputs
- X103** – Modbus TCP / DNP3.0 TCP/UDP, Fiber optics interface, LC Connector
- X104** – IRIG-B00X, incl. System Contact (Supervision Contact)

MRA4-2D1ATA

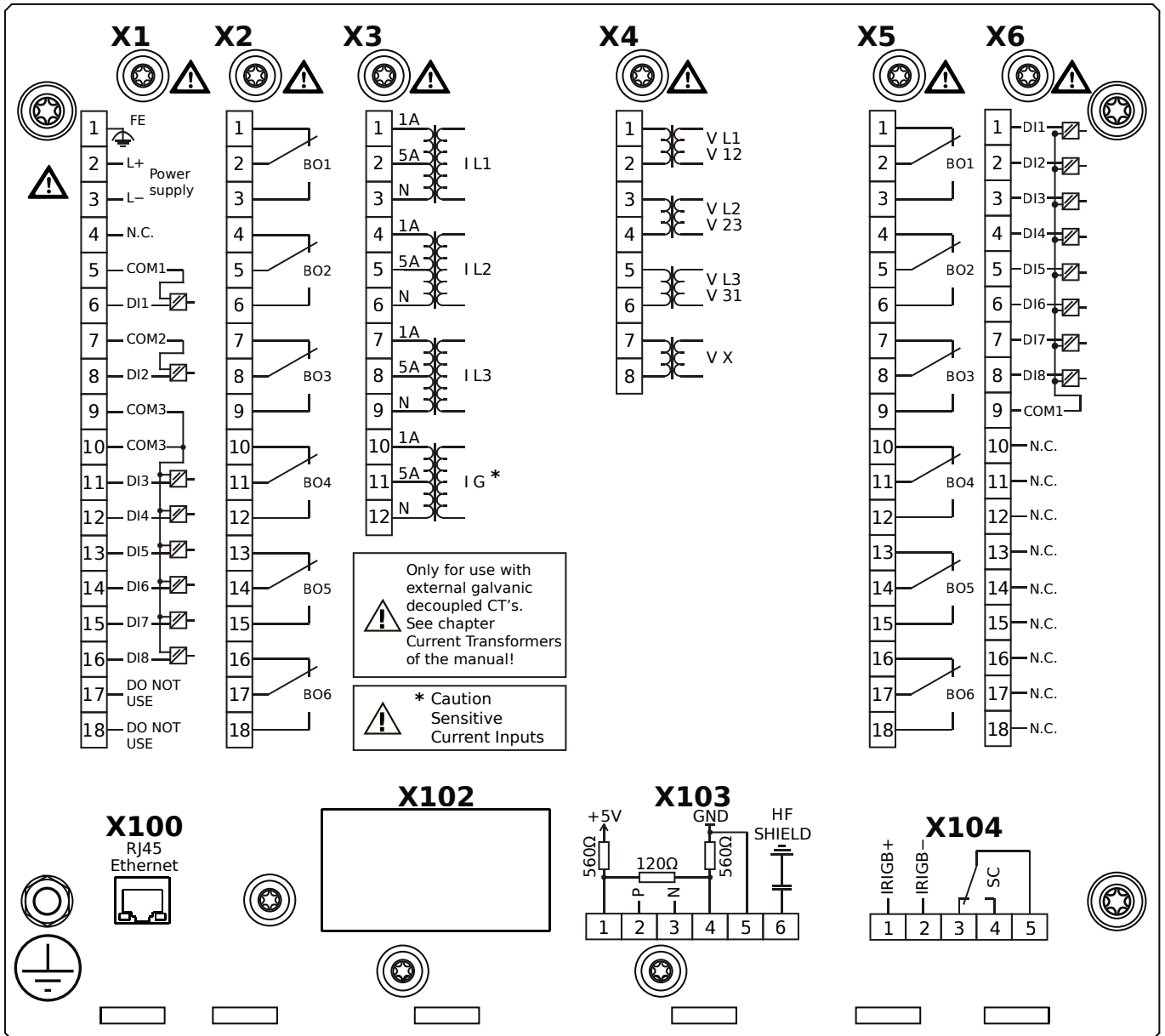

Housing B2, small display, door mounting

- X1** – DI8-X1: Wide-range power supply unit, incl. 2 non-grouped digital inputs and 6 grouped digital inputs
- X2** – OR6: Assembly Group with 6 Output Relays (Changeover / Form C)
- X3** – TIs: Standard phase current measuring card and sensitive ground current measuring
- X4** – TU: Card with 4 voltage transformer measuring inputs (0 ... 800 VAC, under UL: 0 ... 600 VAC)
- X5** – OR6: Assembly Group with 6 Output Relays (Changeover / Form C)
- X6** – DI8: Assembly Group with 8 Digital Inputs
- X100** – IEC 61850 / Modbus TCP / DNP3.0 TCP/UDP, Ethernet interface, 100 Mbit/s, RJ45 (BASE100-FX)
- X103** – IEC 60870-5-103 / Modbus RTU / DNP3.0 RTU, RS485, Terminals
- X104** – IRIG-B00X, incl. System Contact (Supervision Contact)

MRA4-2D1ATB

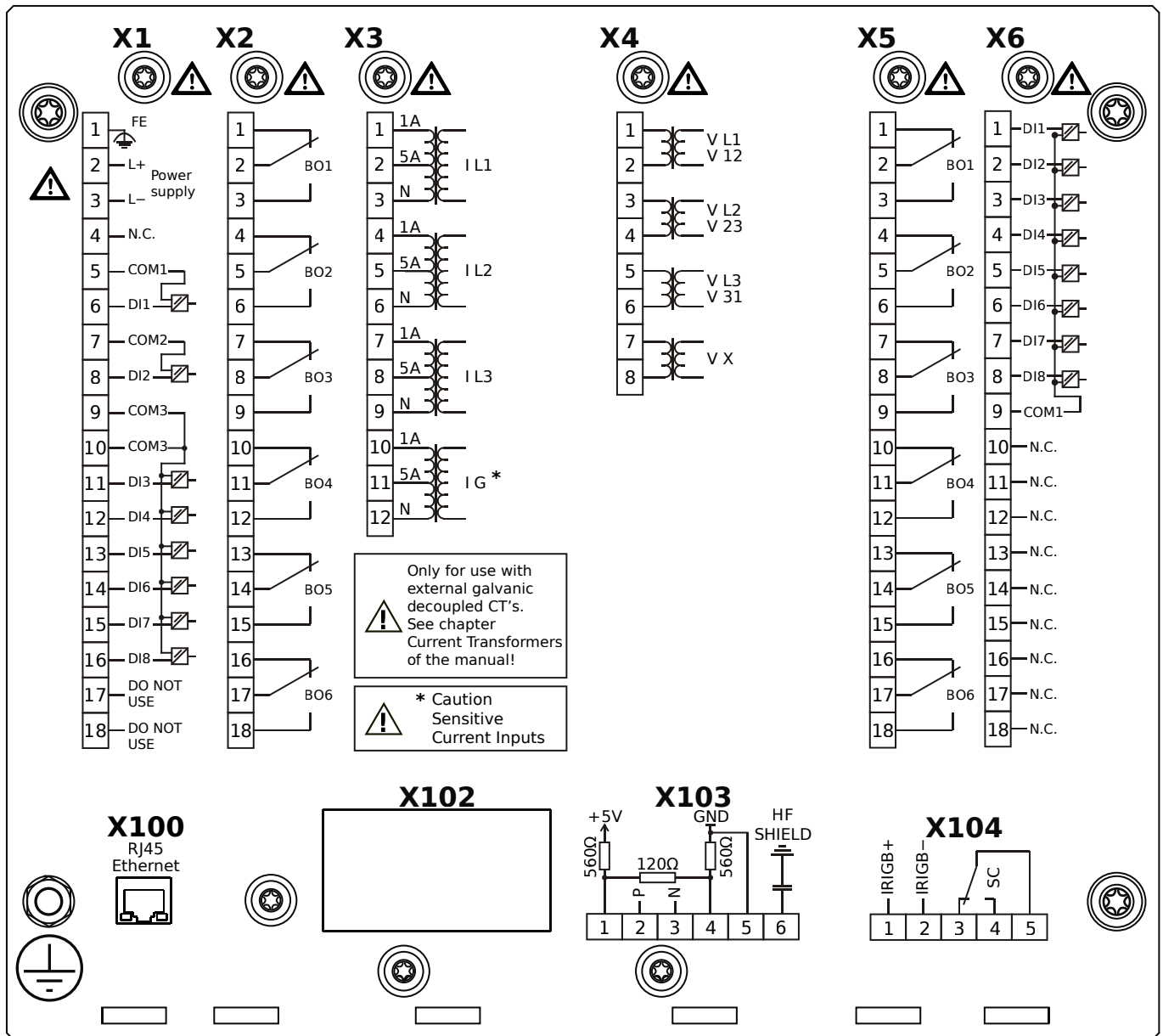

Housing B2, small display, door mounting

+ Conformal Coating (for installations in harsh environment)

- X1** – DI8-X1: Wide-range power supply unit, incl. 2 non-grouped digital inputs and 6 grouped digital inputs
- X2** – OR6: Assembly Group with 6 Output Relays (Changeover / Form C)
- X3** – TIs: Standard phase current measuring card and sensitive ground current measuring
- X4** – TU: Card with 4 voltage transformer measuring inputs (0 ... 800 VAC, under UL: 0 ... 600 VAC)
- X5** – OR6: Assembly Group with 6 Output Relays (Changeover / Form C)
- X6** – DI8: Assembly Group with 8 Digital Inputs
- X100** – IEC 61850 / Modbus TCP / DNP3.0 TCP/UDP, Ethernet interface, 100 Mbit/s, RJ45 (BASE100-FX)
- X103** – IEC 60870-5-103 / Modbus RTU / DNP3.0 RTU, RS485, Terminals
- X104** – IRIG-B00X, incl. System Contact (Supervision Contact)

MRA4-2D1BAA

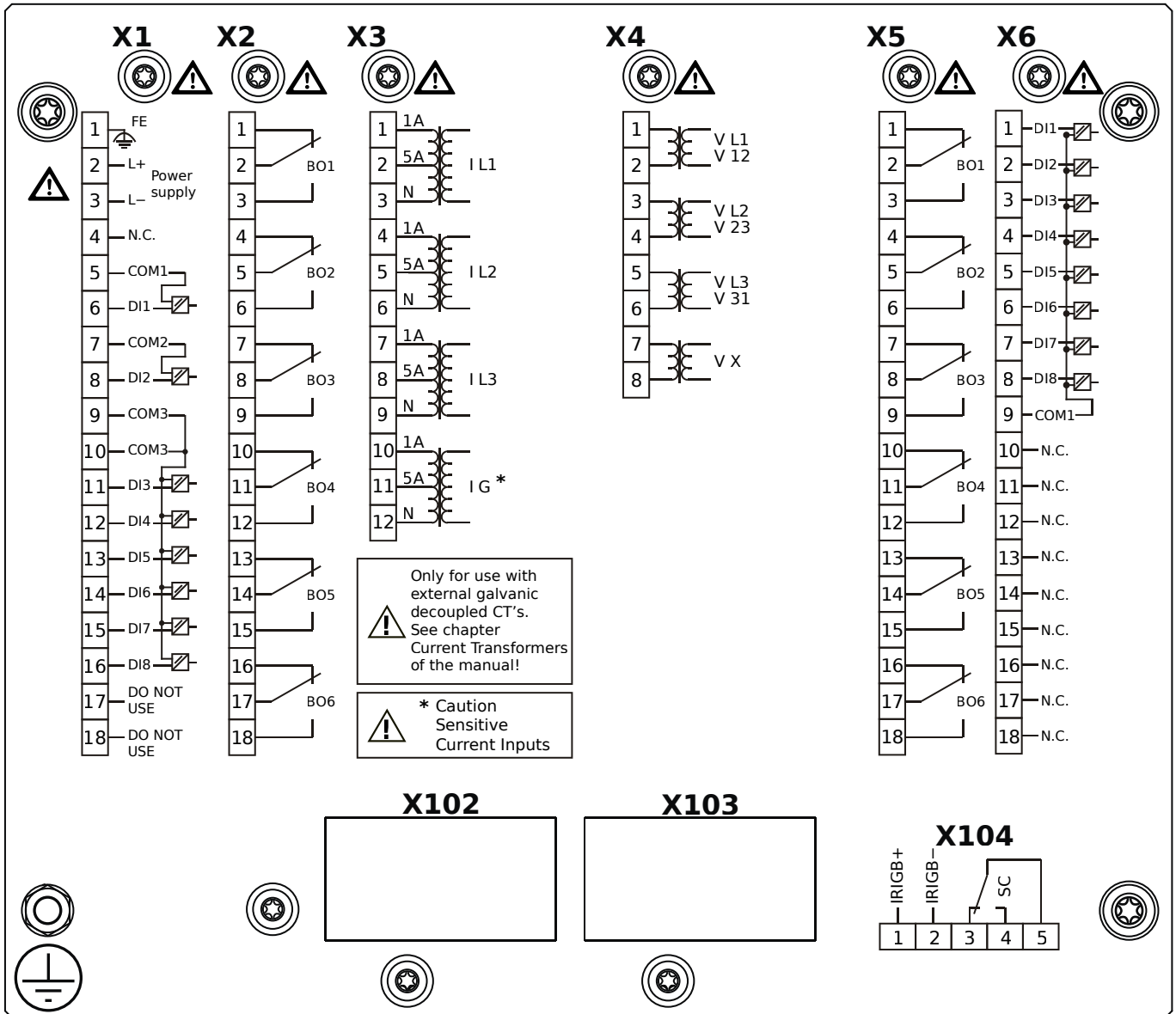

Housing B2, small display, 19" rack mounting

- X1** – DI8-X1: Wide-range power supply unit, incl. 2 non-grouped digital inputs and 6 grouped digital inputs
- X2** – OR6: Assembly Group with 6 Output Relays (Changeover / Form C)
- X3** – TIs: Standard phase current measuring card and sensitive ground current measuring
- X4** – TU: Card with 4 voltage transformer measuring inputs (0 ... 800 VAC, under UL: 0 ... 600 VAC)
- X5** – OR6: Assembly Group with 6 Output Relays (Changeover / Form C)
- X6** – DI8: Assembly Group with 8 Digital Inputs
- X104** – IRIG-B00X, incl. System Contact (Supervision Contact)

MRA4-2D1BAB

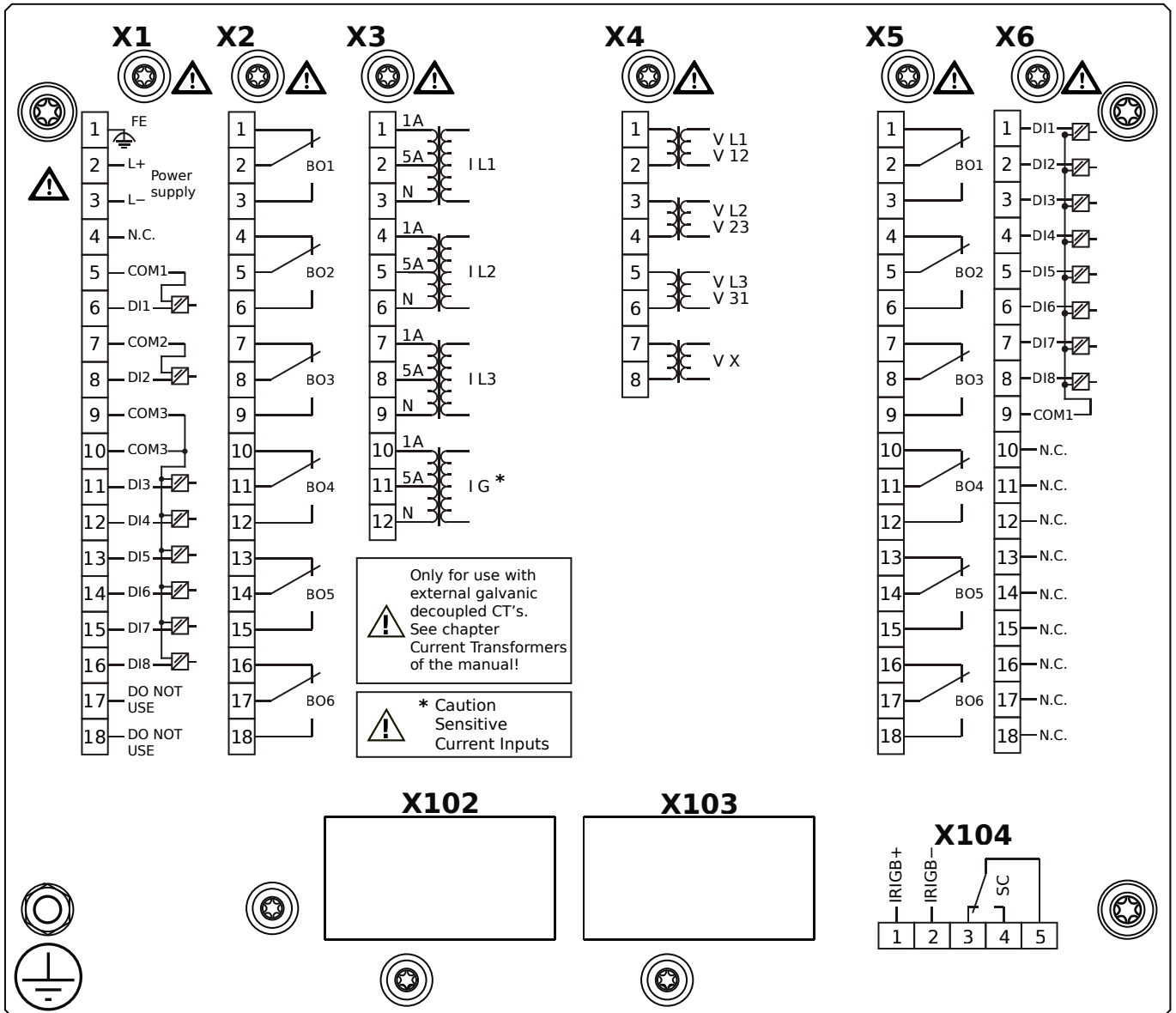

Housing B2, small display, 19" rack mounting

+ Conformal Coating (for installations in harsh environment)

- X1** – DI8-X1: Wide-range power supply unit, incl. 2 non-grouped digital inputs and 6 grouped digital inputs
- X2** – OR6: Assembly Group with 6 Output Relays (Changeover / Form C)
- X3** – TIs: Standard phase current measuring card and sensitive ground current measuring
- X4** – TU: Card with 4 voltage transformer measuring inputs (0 ... 800 VAC, under UL: 0 ... 600 VAC)
- X5** – OR6: Assembly Group with 6 Output Relays (Changeover / Form C)
- X6** – DI8: Assembly Group with 8 Digital Inputs
- X104** – IRIG-B00X, incl. System Contact (Supervision Contact)

MRA4-2D1BBA

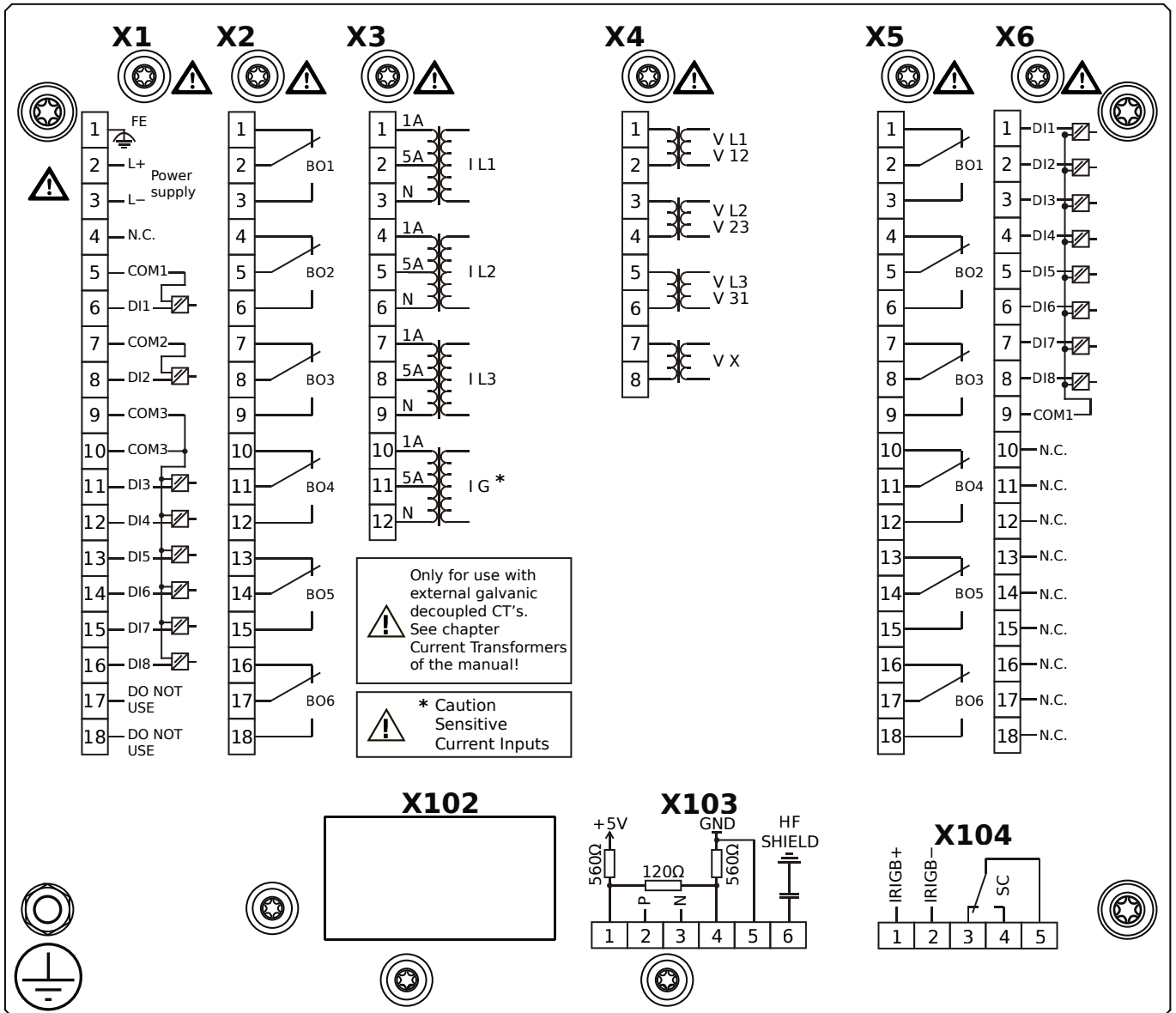

Housing B2, small display, 19" rack mounting

- X1** – DI8-X1: Wide-range power supply unit, incl. 2 non-grouped digital inputs and 6 grouped digital inputs
- X2** – OR6: Assembly Group with 6 Output Relays (Changeover / Form C)
- X3** – TIs: Standard phase current measuring card and sensitive ground current measuring
- X4** – TU: Card with 4 voltage transformer measuring inputs (0 ... 800 VAC, under UL: 0 ... 600 VAC)
- X5** – OR6: Assembly Group with 6 Output Relays (Changeover / Form C)
- X6** – DI8: Assembly Group with 8 Digital Inputs
- X103** – Modbus RTU / IEC 60870-5-103 / DNP3.0 RTU, RS485, Terminals
- X104** – IRIG-B00X, incl. System Contact (Supervision Contact)

MRA4-2D1BBB

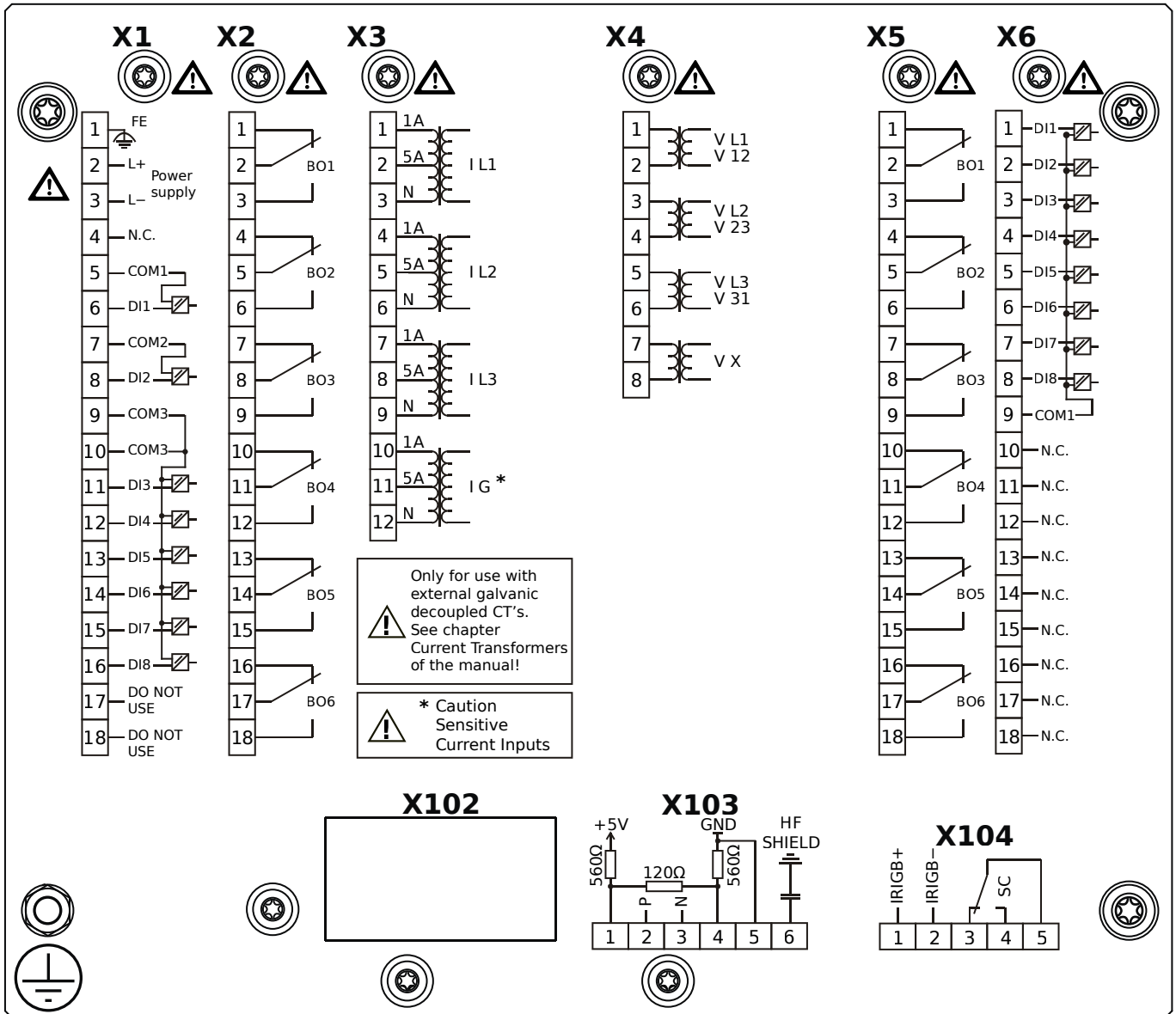

Housing B2, small display, 19" rack mounting

+ Conformal Coating (for installations in harsh environment)

- X1** – DI8-X1: Wide-range power supply unit, incl. 2 non-grouped digital inputs and 6 grouped digital inputs
- X2** – OR6: Assembly Group with 6 Output Relays (Changeover / Form C)
- X3** – TIs: Standard phase current measuring card and sensitive ground current measuring
- X4** – TU: Card with 4 voltage transformer measuring inputs (0 ... 800 VAC, under UL: 0 ... 600 VAC)
- X5** – OR6: Assembly Group with 6 Output Relays (Changeover / Form C)
- X6** – DI8: Assembly Group with 8 Digital Inputs
- X103** – Modbus RTU / IEC 60870-5-103 / DNP3.0 RTU, RS485, Terminals
- X104** – IRIG-B00X, incl. System Contact (Supervision Contact)

MRA4-2D1BCA

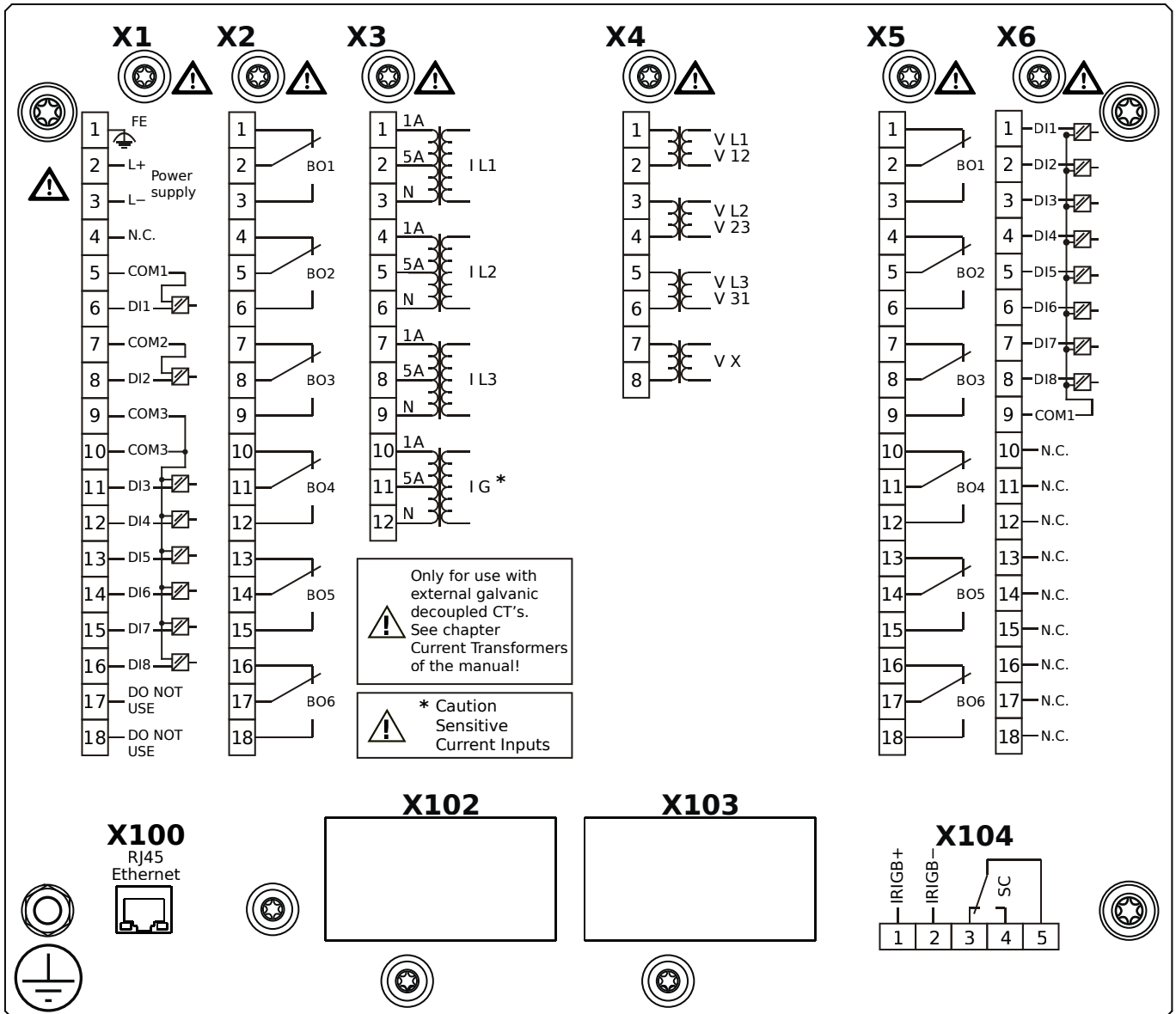

Housing B2, small display, 19" rack mounting

- X1** – DI8-X1: Wide-range power supply unit, incl. 2 non-grouped digital inputs and 6 grouped digital inputs
- X2** – OR6: Assembly Group with 6 Output Relays (Changeover / Form C)
- X3** – TIs: Standard phase current measuring card and sensitive ground current measuring
- X4** – TU: Card with 4 voltage transformer measuring inputs (0 ... 800 VAC, under UL: 0 ... 600 VAC)
- X5** – OR6: Assembly Group with 6 Output Relays (Changeover / Form C)
- X6** – DI8: Assembly Group with 8 Digital Inputs
- X100** – Modbus TCP / DNP3.0 TCP/UDP, Ethernet interface, 100 Mbit/s, RJ45 (BASE100-FX)
- X104** – IRIG-B00X, incl. System Contact (Supervision Contact)

MRA4-2D1BCB

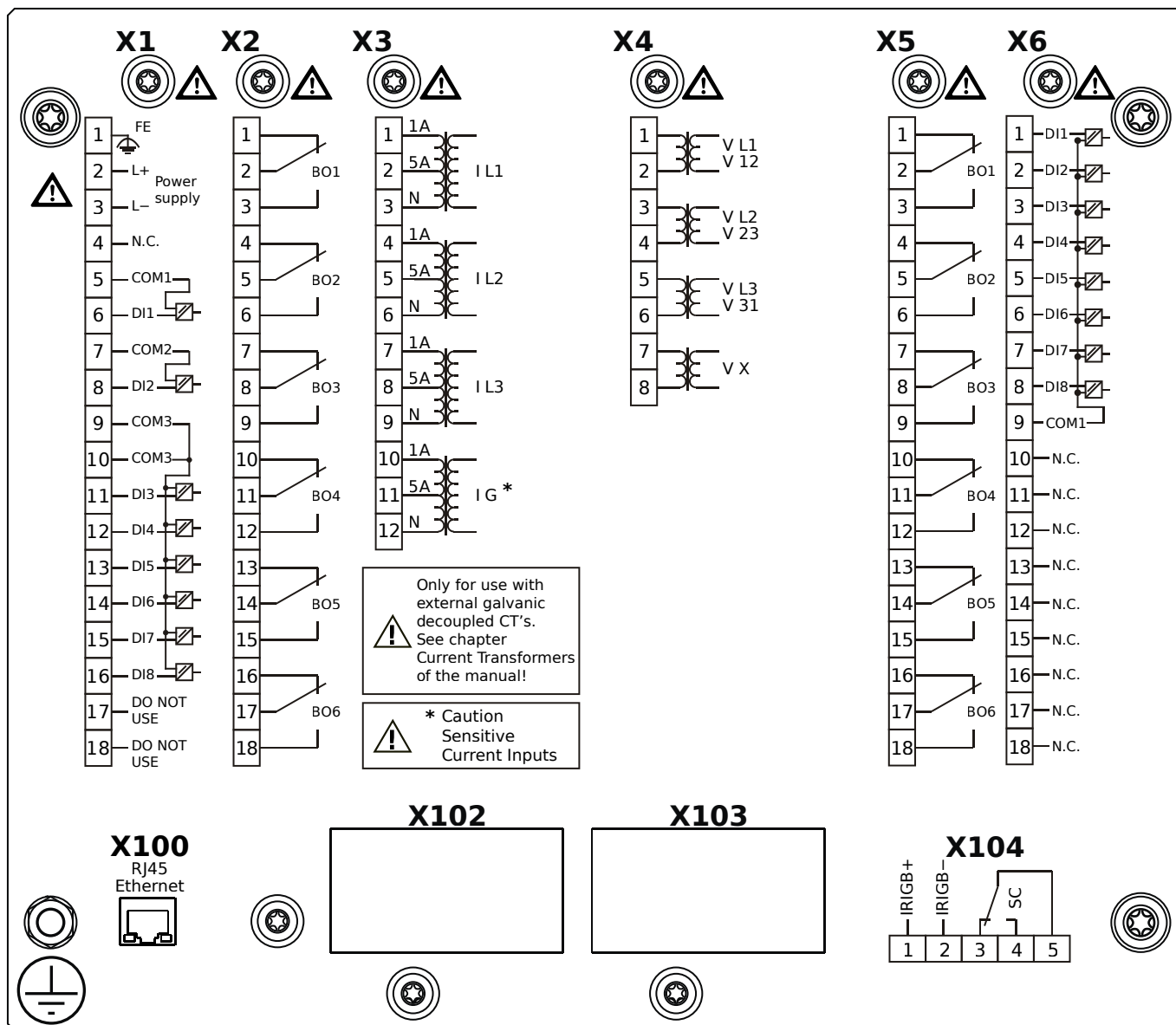

Housing B2, small display, 19" rack mounting

+ Conformal Coating (for installations in harsh environment)

- X1** – DI8-X1: Wide-range power supply unit, incl. 2 non-grouped digital inputs and 6 grouped digital inputs
- X2** – OR6: Assembly Group with 6 Output Relays (Changeover / Form C)
- X3** – TIs: Standard phase current measuring card and sensitive ground current measuring
- X4** – TU: Card with 4 voltage transformer measuring inputs (0 ... 800 VAC, under UL: 0 ... 600 VAC)
- X5** – OR6: Assembly Group with 6 Output Relays (Changeover / Form C)
- X6** – DI8: Assembly Group with 8 Digital Inputs
- X100** – Modbus TCP / DNP3.0 TCP/UDP, Ethernet interface, 100 Mbit/s, RJ45 (BASE100-FX)
- X104** – IRIG-B00X, incl. System Contact (Supervision Contact)

MRA4-2D1BDA

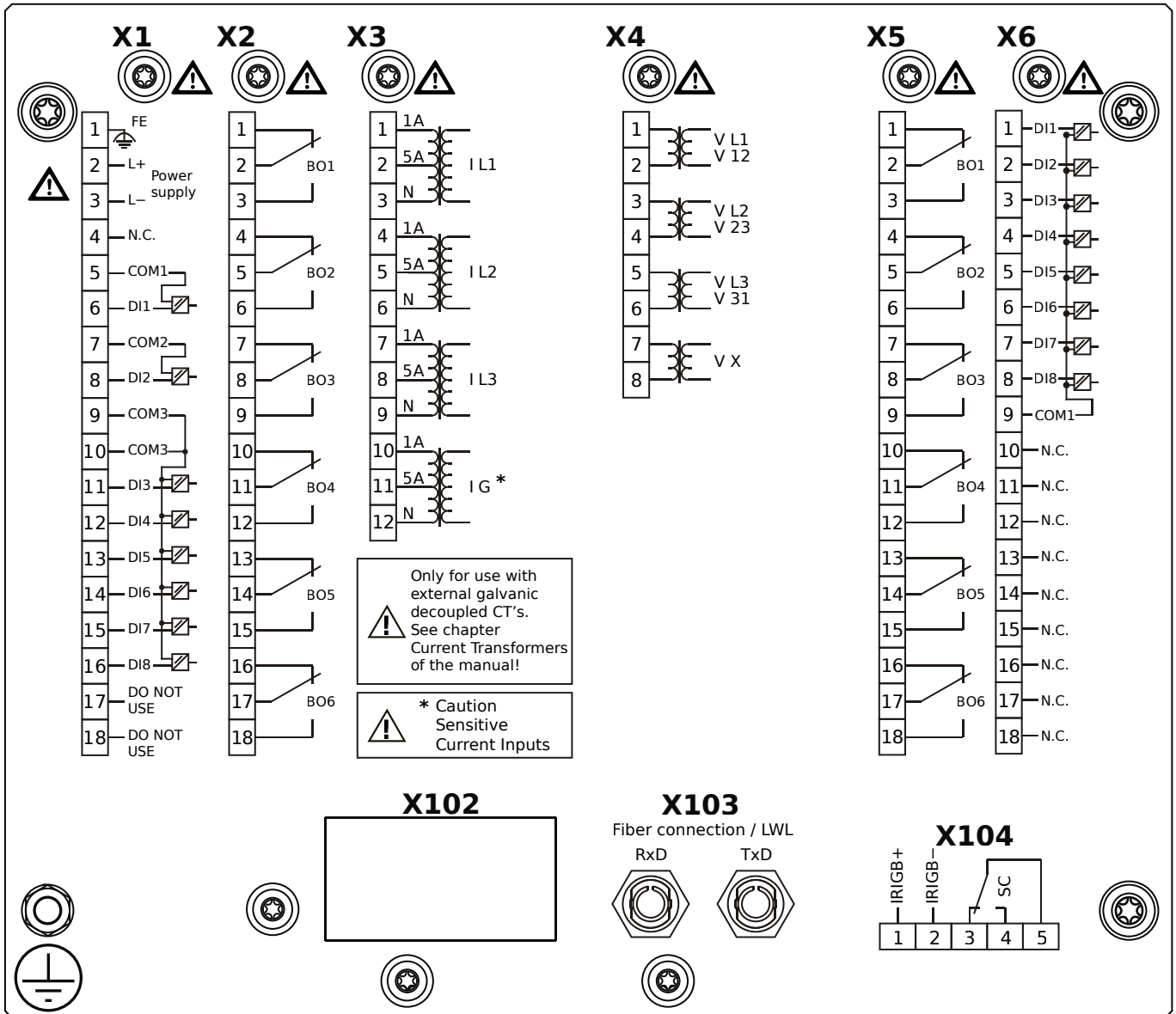

Housing B2, small display, 19" rack mounting

- X1** – DI8-X1: Wide-range power supply unit, incl. 2 non-grouped digital inputs and 6 grouped digital inputs
- X2** – OR6: Assembly Group with 6 Output Relays (Changeover / Form C)
- X3** – TIs: Standard phase current measuring card and sensitive ground current measuring
- X4** – TU: Card with 4 voltage transformer measuring inputs (0 ... 800 VAC, under UL: 0 ... 600 VAC)
- X5** – OR6: Assembly Group with 6 Output Relays (Changeover / Form C)
- X6** – DI8: Assembly Group with 8 Digital Inputs
- X103** – Profibus-DP, Fiber optics interface, ST Connector
- X104** – IRIG-B00X, incl. System Contact (Supervision Contact)

MRA4-2D1BDB

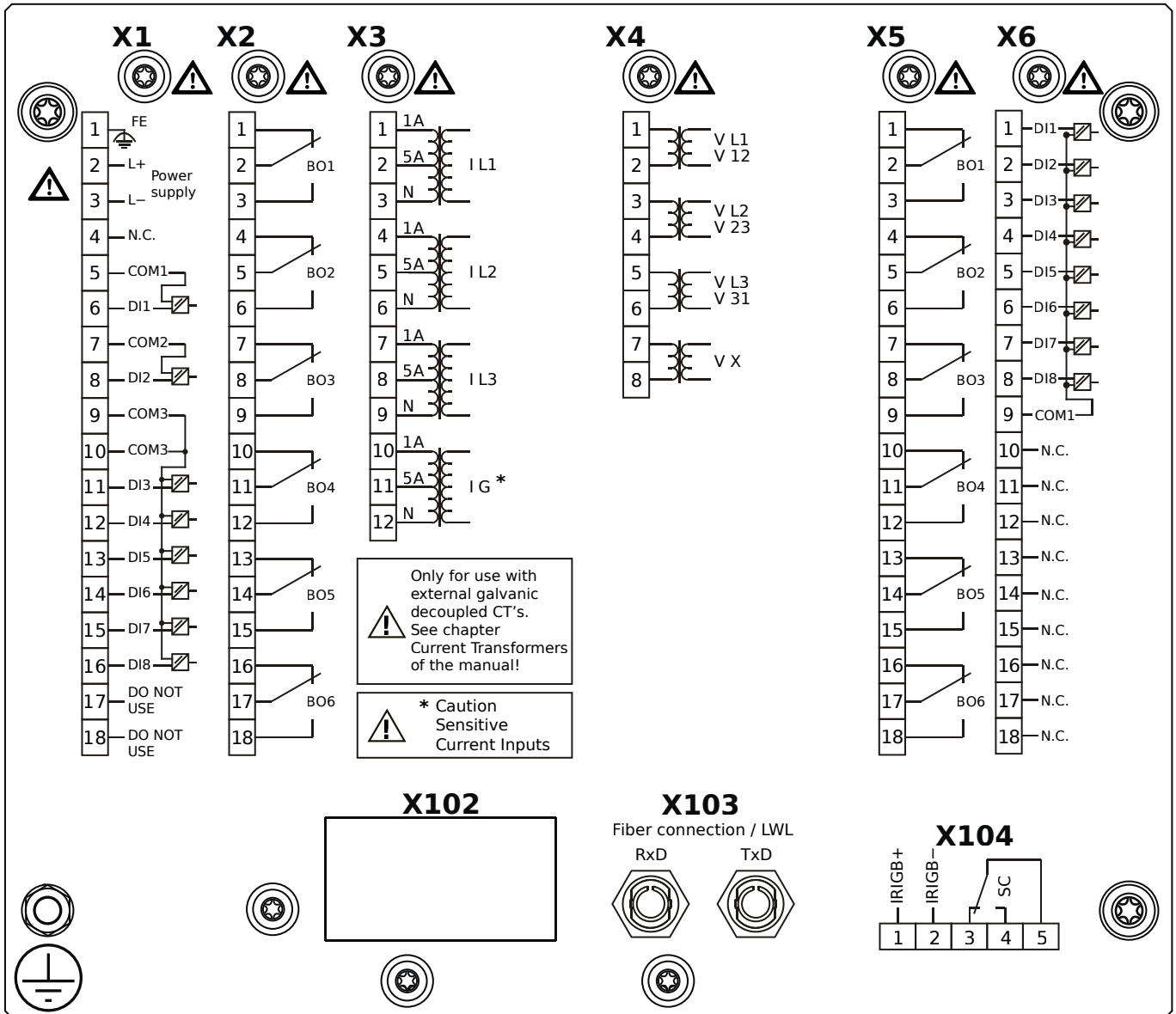

Housing B2, small display, 19" rack mounting

+ Conformal Coating (for installations in harsh environment)

- X1** – DI8-X1: Wide-range power supply unit, incl. 2 non-grouped digital inputs and 6 grouped digital inputs
- X2** – OR6: Assembly Group with 6 Output Relays (Changeover / Form C)
- X3** – TIs: Standard phase current measuring card and sensitive ground current measuring
- X4** – TU: Card with 4 voltage transformer measuring inputs (0 ... 800 VAC, under UL: 0 ... 600 VAC)
- X5** – OR6: Assembly Group with 6 Output Relays (Changeover / Form C)
- X6** – DI8: Assembly Group with 8 Digital Inputs
- X103** – Profibus-DP, Fiber optics interface, ST Connector
- X104** – IRIG-B00X, incl. System Contact (Supervision Contact)

MRA4-2D1BEA

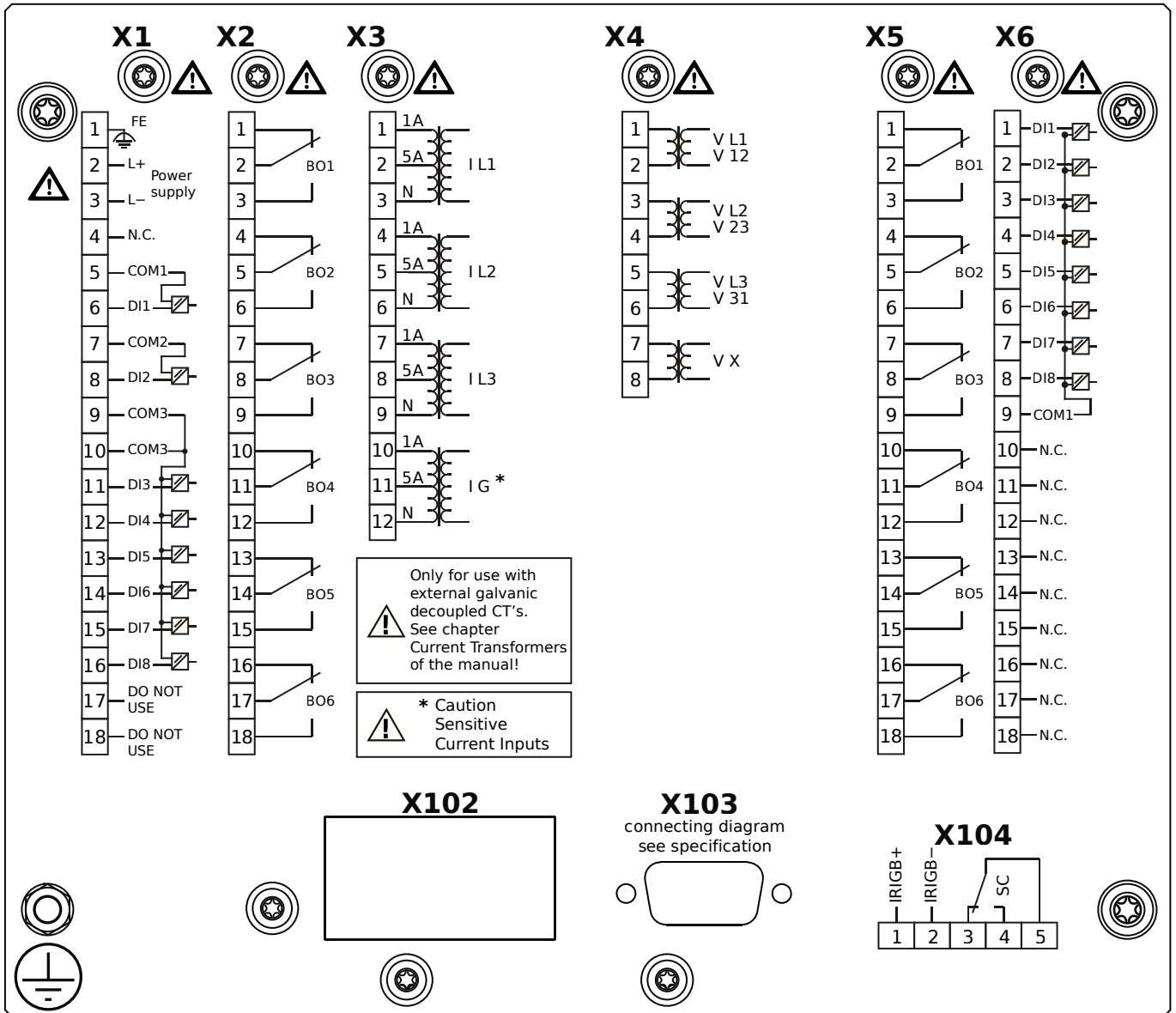

Housing B2, small display, 19" rack mounting

- X1** – DI8-X1: Wide-range power supply unit, incl. 2 non-grouped digital inputs and 6 grouped digital inputs
- X2** – OR6: Assembly Group with 6 Output Relays (Changeover / Form C)
- X3** – TIs: Standard phase current measuring card and sensitive ground current measuring
- X4** – TU: Card with 4 voltage transformer measuring inputs (0 ... 800 VAC, under UL: 0 ... 600 VAC)
- X5** – OR6: Assembly Group with 6 Output Relays (Changeover / Form C)
- X6** – DI8: Assembly Group with 8 Digital Inputs
- X103** – Profibus-DP, RS485, D-SUB
- X104** – IRIG-B00X, incl. System Contact (Supervision Contact)

MRA4-2D1BEB

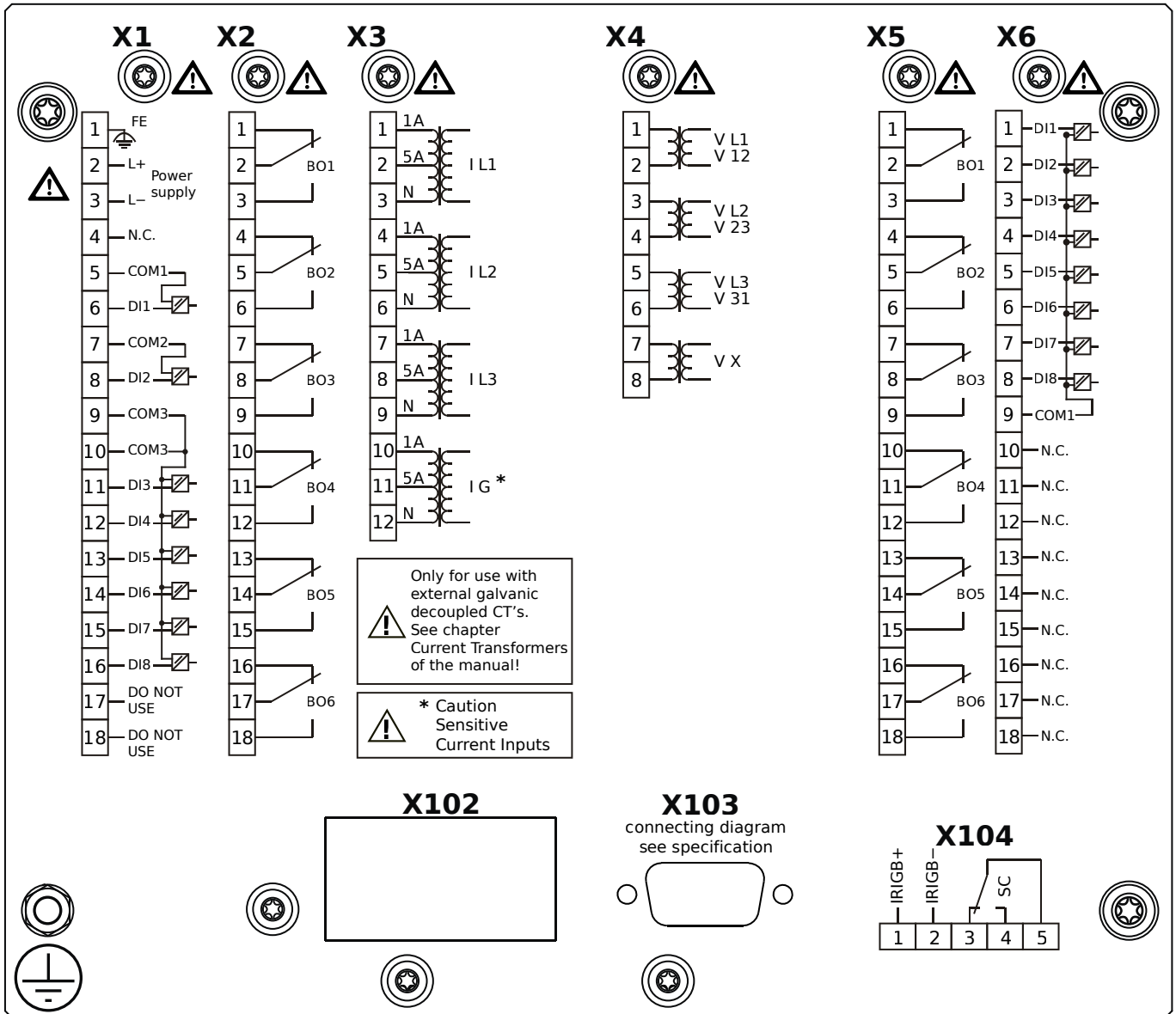

Housing B2, small display, 19" rack mounting

+ Conformal Coating (for installations in harsh environment)

- X1** – DI8-X1: Wide-range power supply unit, incl. 2 non-grouped digital inputs and 6 grouped digital inputs
- X2** – OR6: Assembly Group with 6 Output Relays (Changeover / Form C)
- X3** – TIs: Standard phase current measuring card and sensitive ground current measuring
- X4** – TU: Card with 4 voltage transformer measuring inputs (0 ... 800 VAC, under UL: 0 ... 600 VAC)
- X5** – OR6: Assembly Group with 6 Output Relays (Changeover / Form C)
- X6** – DI8: Assembly Group with 8 Digital Inputs
- X103** – Profibus-DP, RS485, D-SUB
- X104** – IRIG-B00X, incl. System Contact (Supervision Contact)

MRA4-2D1BFA

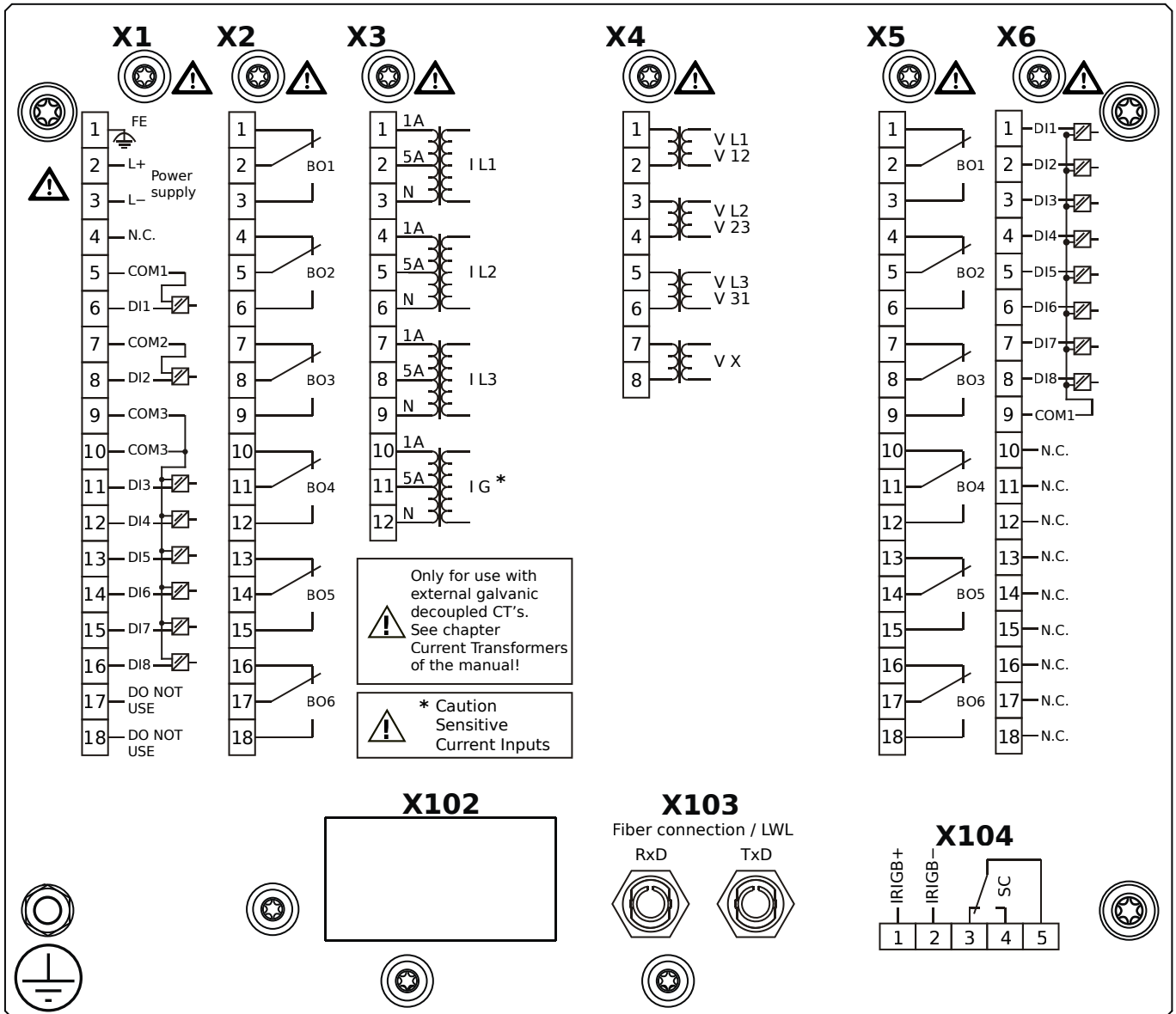

Housing B2, small display, 19" rack mounting

- X1** – DI8-X1: Wide-range power supply unit, incl. 2 non-grouped digital inputs and 6 grouped digital inputs
- X2** – OR6: Assembly Group with 6 Output Relays (Changeover / Form C)
- X3** – TIs: Standard phase current measuring card and sensitive ground current measuring
- X4** – TU: Card with 4 voltage transformer measuring inputs (0 ... 800 VAC, under UL: 0 ... 600 VAC)
- X5** – OR6: Assembly Group with 6 Output Relays (Changeover / Form C)
- X6** – DI8: Assembly Group with 8 Digital Inputs
- X103** – Modbus RTU / IEC 60870-5-103 / DNP3.0 RTU, Fiber optics interface, ST Connector
- X104** – IRIG-B00X, incl. System Contact (Supervision Contact)

MRA4-2D1BFB

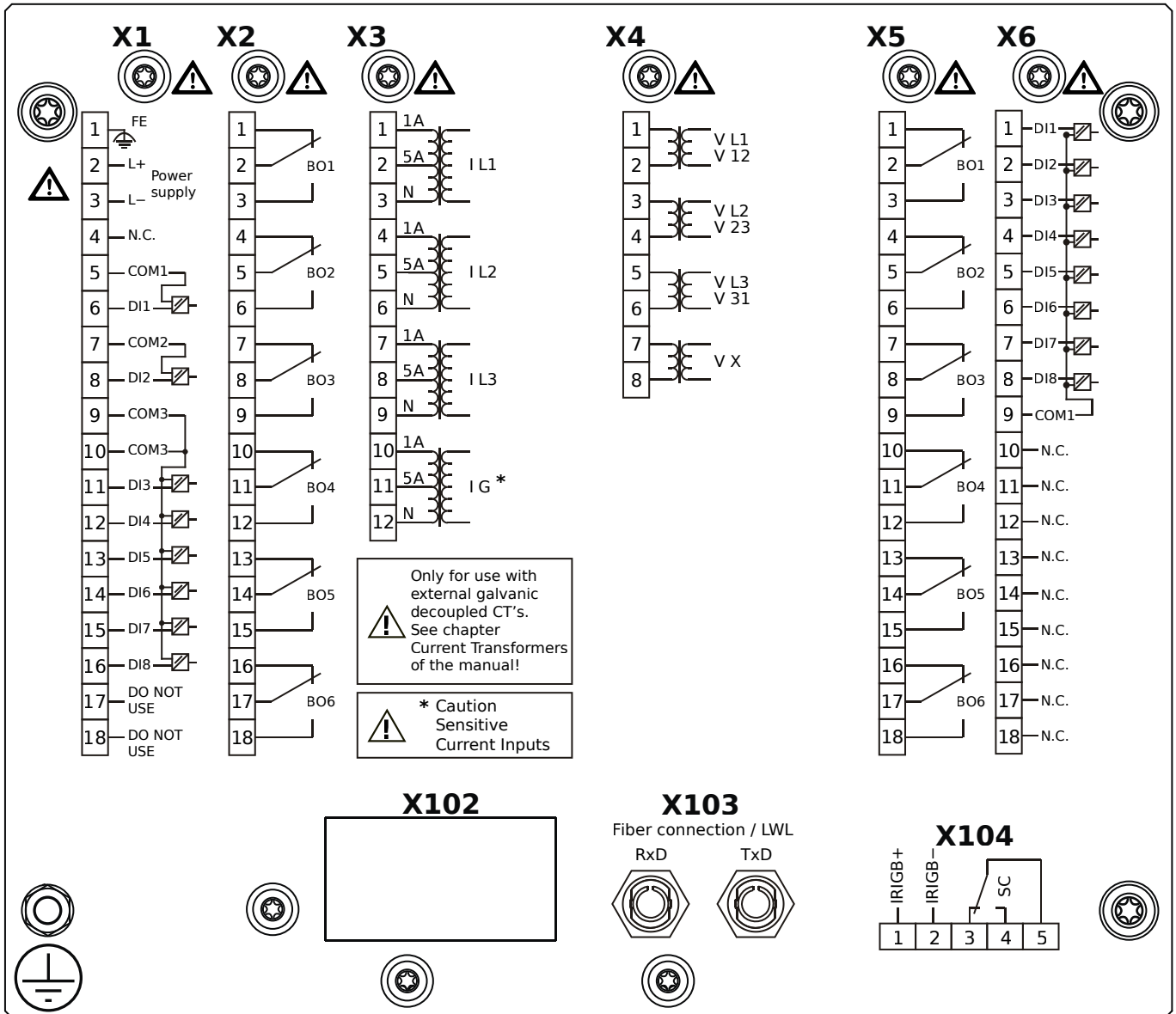

Housing B2, small display, 19" rack mounting

+ Conformal Coating (for installations in harsh environment)

- X1** – DI8-X1: Wide-range power supply unit, incl. 2 non-grouped digital inputs and 6 grouped digital inputs
- X2** – OR6: Assembly Group with 6 Output Relays (Changeover / Form C)
- X3** – TIs: Standard phase current measuring card and sensitive ground current measuring
- X4** – TU: Card with 4 voltage transformer measuring inputs (0 ... 800 VAC, under UL: 0 ... 600 VAC)
- X5** – OR6: Assembly Group with 6 Output Relays (Changeover / Form C)
- X6** – DI8: Assembly Group with 8 Digital Inputs
- X103** – Modbus RTU / IEC 60870-5-103 / DNP3.0 RTU, Fiber optics interface, ST Connector
- X104** – IRIG-B00X, incl. System Contact (Supervision Contact)

MRA4-2D1BGA

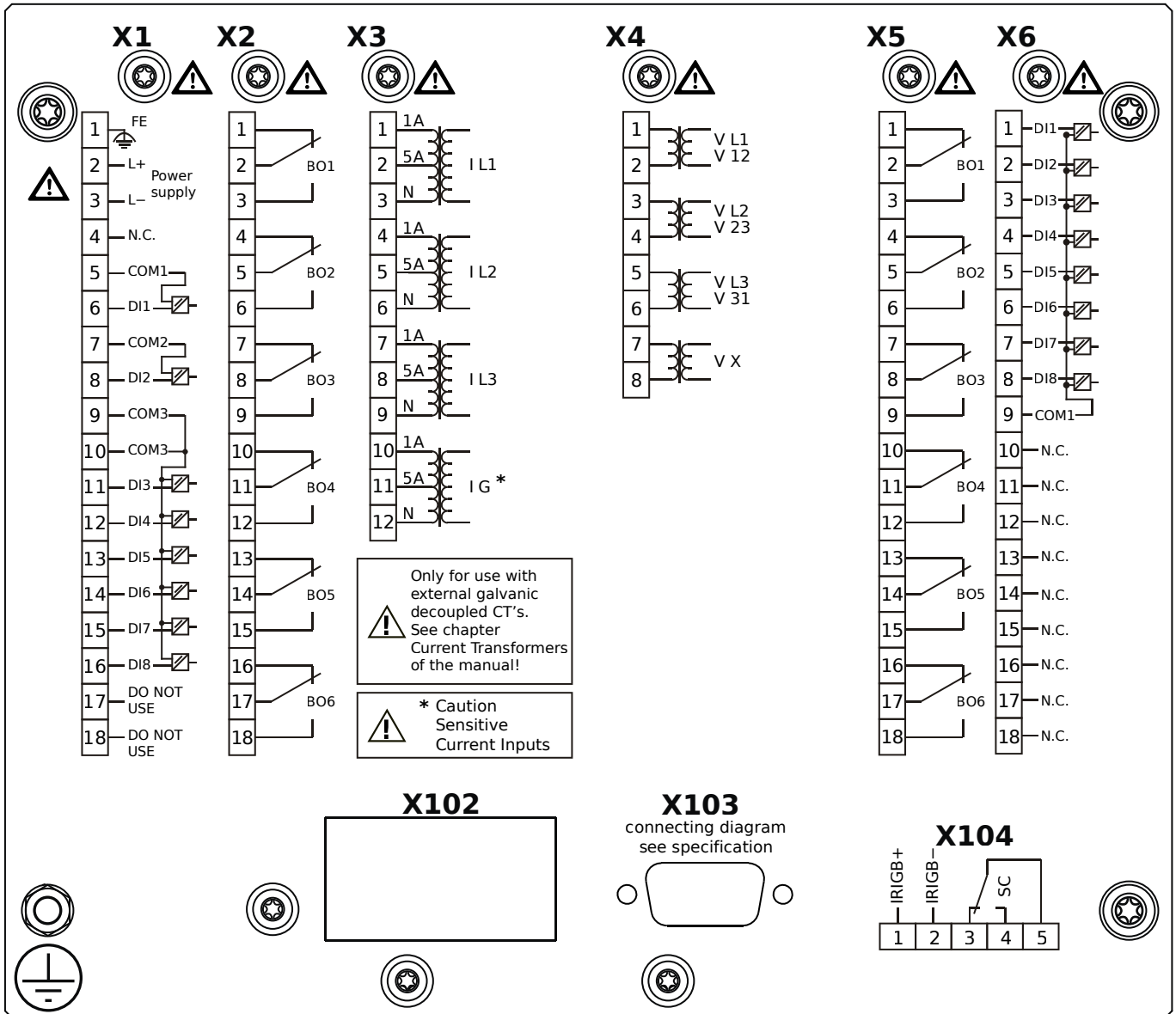

Housing B2, small display, 19" rack mounting

- X1** – DI8-X1: Wide-range power supply unit, incl. 2 non-grouped digital inputs and 6 grouped digital inputs
- X2** – OR6: Assembly Group with 6 Output Relays (Changeover / Form C)
- X3** – TIs: Standard phase current measuring card and sensitive ground current measuring
- X4** – TU: Card with 4 voltage transformer measuring inputs (0 ... 800 VAC, under UL: 0 ... 600 VAC)
- X5** – OR6: Assembly Group with 6 Output Relays (Changeover / Form C)
- X6** – DI8: Assembly Group with 8 Digital Inputs
- X103** – Modbus RTU / IEC 60870-5-103 / DNP3.0 RTU, RS485, D-SUB
- X104** – IRIG-B00X, incl. System Contact (Supervision Contact)

MRA4-2D1BGB

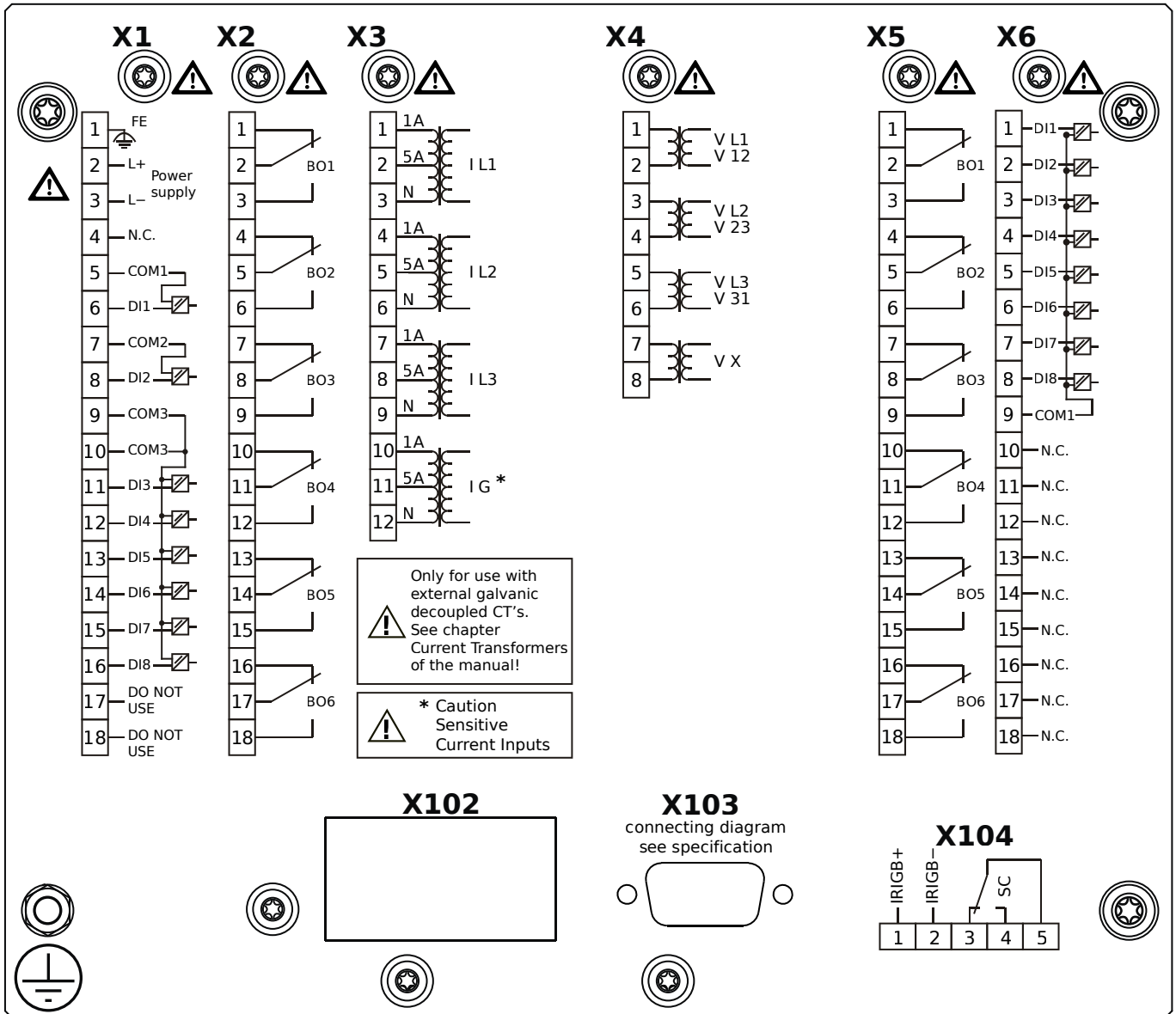

Housing B2, small display, 19" rack mounting

+ Conformal Coating (for installations in harsh environment)

- X1** – DI8-X1: Wide-range power supply unit, incl. 2 non-grouped digital inputs and 6 grouped digital inputs
- X2** – OR6: Assembly Group with 6 Output Relays (Changeover / Form C)
- X3** – TIs: Standard phase current measuring card and sensitive ground current measuring
- X4** – TU: Card with 4 voltage transformer measuring inputs (0 ... 800 VAC, under UL: 0 ... 600 VAC)
- X5** – OR6: Assembly Group with 6 Output Relays (Changeover / Form C)
- X6** – DI8: Assembly Group with 8 Digital Inputs
- X103** – Modbus RTU / IEC 60870-5-103 / DNP3.0 RTU, RS485, D-SUB
- X104** – IRIG-B00X, incl. System Contact (Supervision Contact)

MRA4-2D1BHA

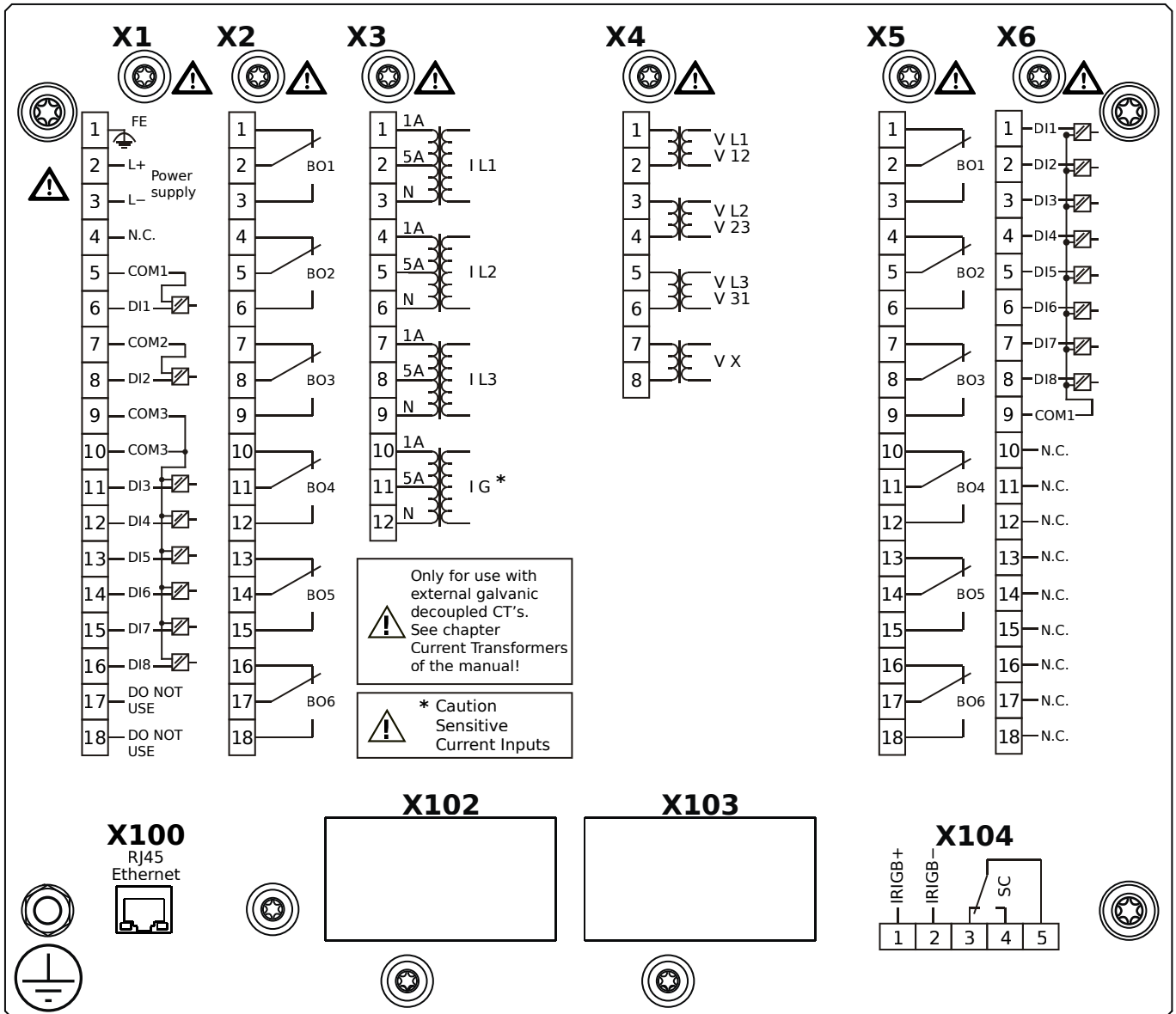

Housing B2, small display, 19" rack mounting

- X1** – DI8-X1: Wide-range power supply unit, incl. 2 non-grouped digital inputs and 6 grouped digital inputs
- X2** – OR6: Assembly Group with 6 Output Relays (Changeover / Form C)
- X3** – TIs: Standard phase current measuring card and sensitive ground current measuring
- X4** – TU: Card with 4 voltage transformer measuring inputs (0 ... 800 VAC, under UL: 0 ... 600 VAC)
- X5** – OR6: Assembly Group with 6 Output Relays (Changeover / Form C)
- X6** – DI8: Assembly Group with 8 Digital Inputs
- X100** – IEC 61850 / Modbus TCP / DNP3.0 TCP/UDP, Ethernet interface, 100 Mbit/s, RJ45 (BASE100-FX)
- X104** – IRIG-B00X, incl. System Contact (Supervision Contact)

MRA4-2D1BHB

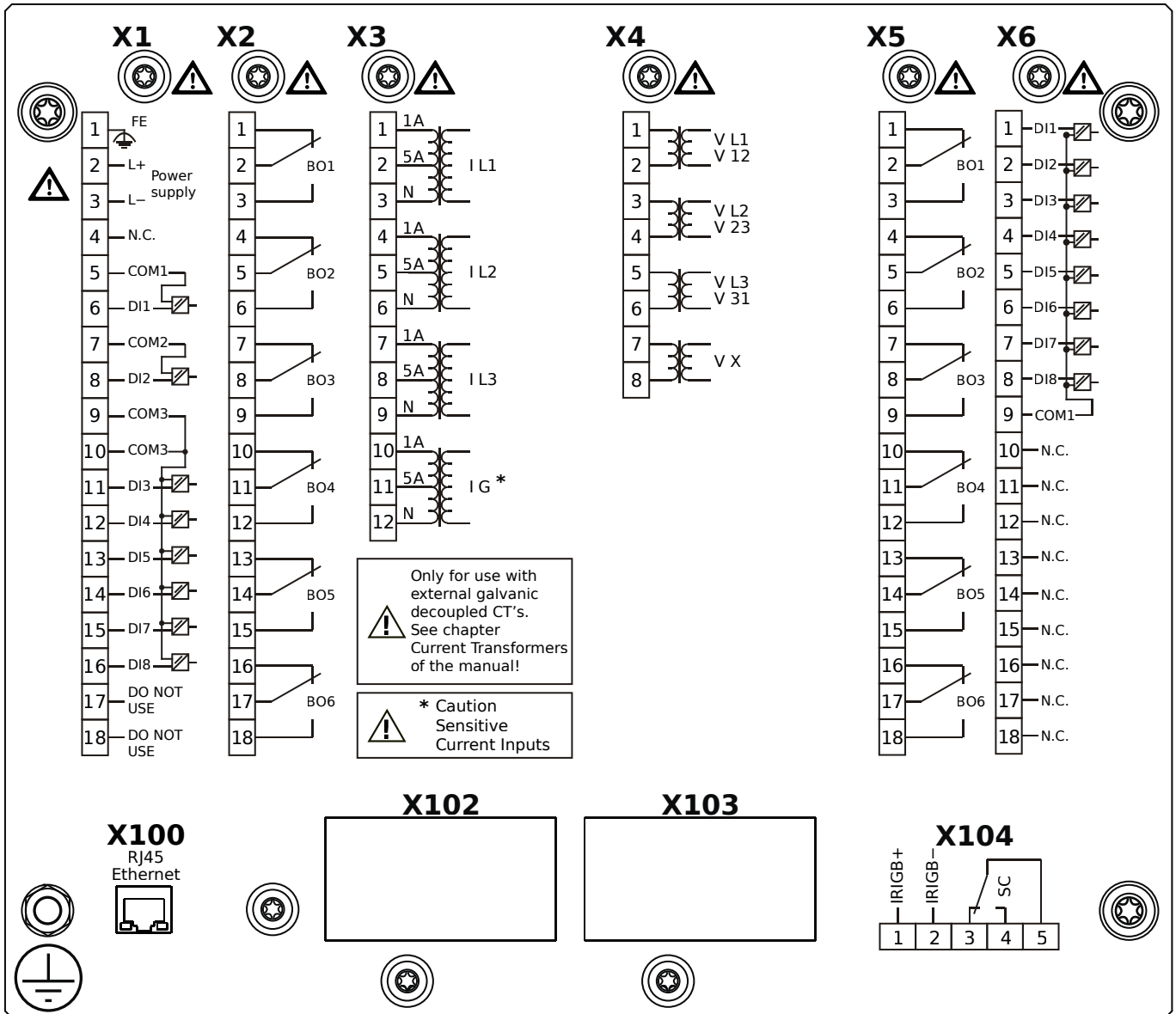

Housing B2, small display, 19" rack mounting

+ Conformal Coating (for installations in harsh environment)

- X1** – DI8-X1: Wide-range power supply unit, incl. 2 non-grouped digital inputs and 6 grouped digital inputs
- X2** – OR6: Assembly Group with 6 Output Relays (Changeover / Form C)
- X3** – TIs: Standard phase current measuring card and sensitive ground current measuring
- X4** – TU: Card with 4 voltage transformer measuring inputs (0 ... 800 VAC, under UL: 0 ... 600 VAC)
- X5** – OR6: Assembly Group with 6 Output Relays (Changeover / Form C)
- X6** – DI8: Assembly Group with 8 Digital Inputs
- X100** – IEC 61850 / Modbus TCP / DNP3.0 TCP/UDP, Ethernet interface, 100 Mbit/s, RJ45 (BASE100-FX)
- X104** – IRIG-B00X, incl. System Contact (Supervision Contact)

MRA4-2D1BIA

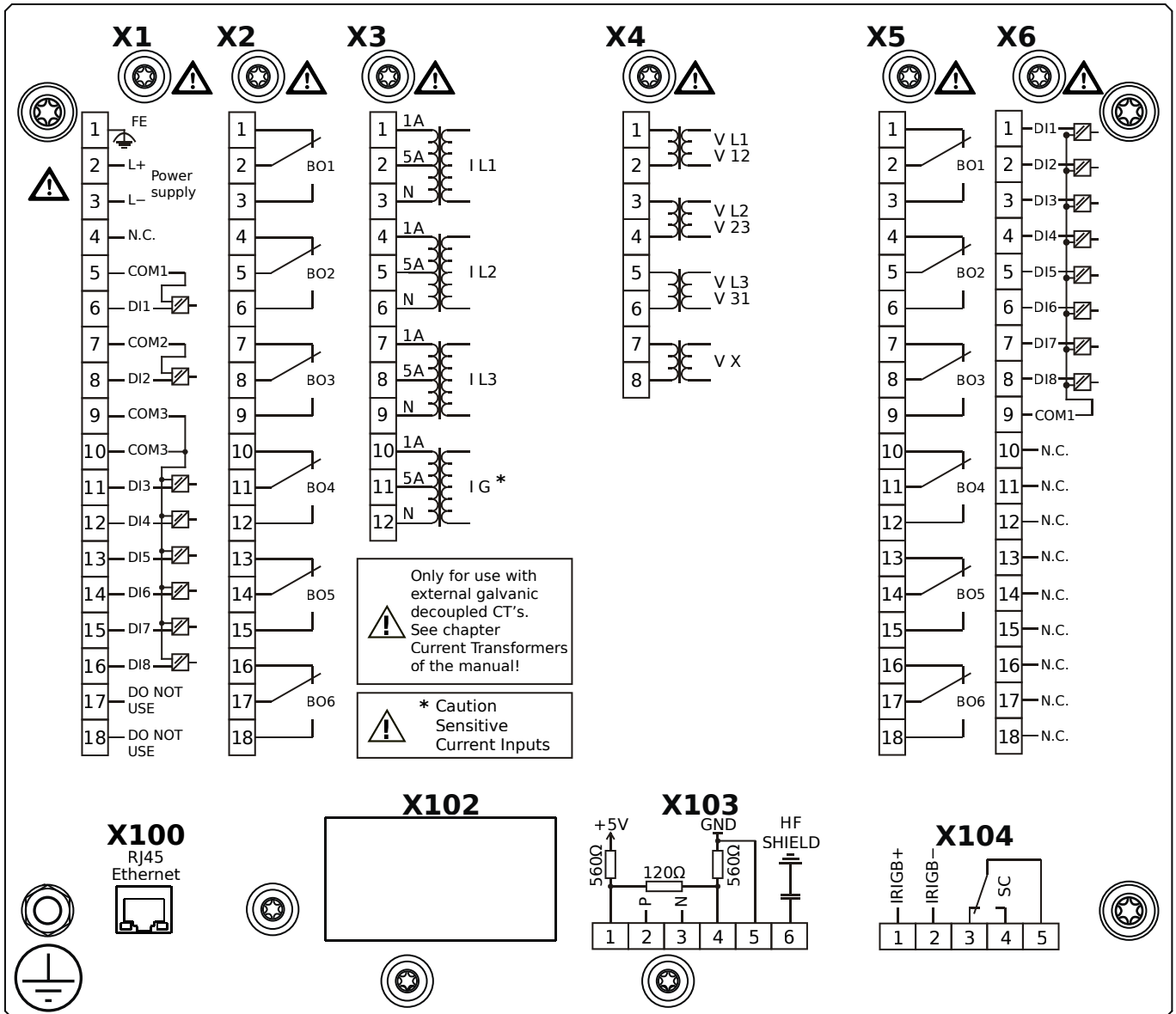

Housing B2, small display, 19" rack mounting

- X1** – DI8-X1: Wide-range power supply unit, incl. 2 non-grouped digital inputs and 6 grouped digital inputs
- X2** – OR6: Assembly Group with 6 Output Relays (Changeover / Form C)
- X3** – TIs: Standard phase current measuring card and sensitive ground current measuring
- X4** – TU: Card with 4 voltage transformer measuring inputs (0 ... 800 VAC, under UL: 0 ... 600 VAC)
- X5** – OR6: Assembly Group with 6 Output Relays (Changeover / Form C)
- X6** – DI8: Assembly Group with 8 Digital Inputs
- X100** – Modbus TCP / DNP3.0 TCP/UDP, Ethernet interface, 100 Mbit/s, RJ45 (BASE100-FX)
- X103** – IEC 60870-5-103 / Modbus RTU / DNP3.0 RTU, RS485, Terminals
- X104** – IRIG-B00X, incl. System Contact (Supervision Contact)

MRA4-2D1BIB

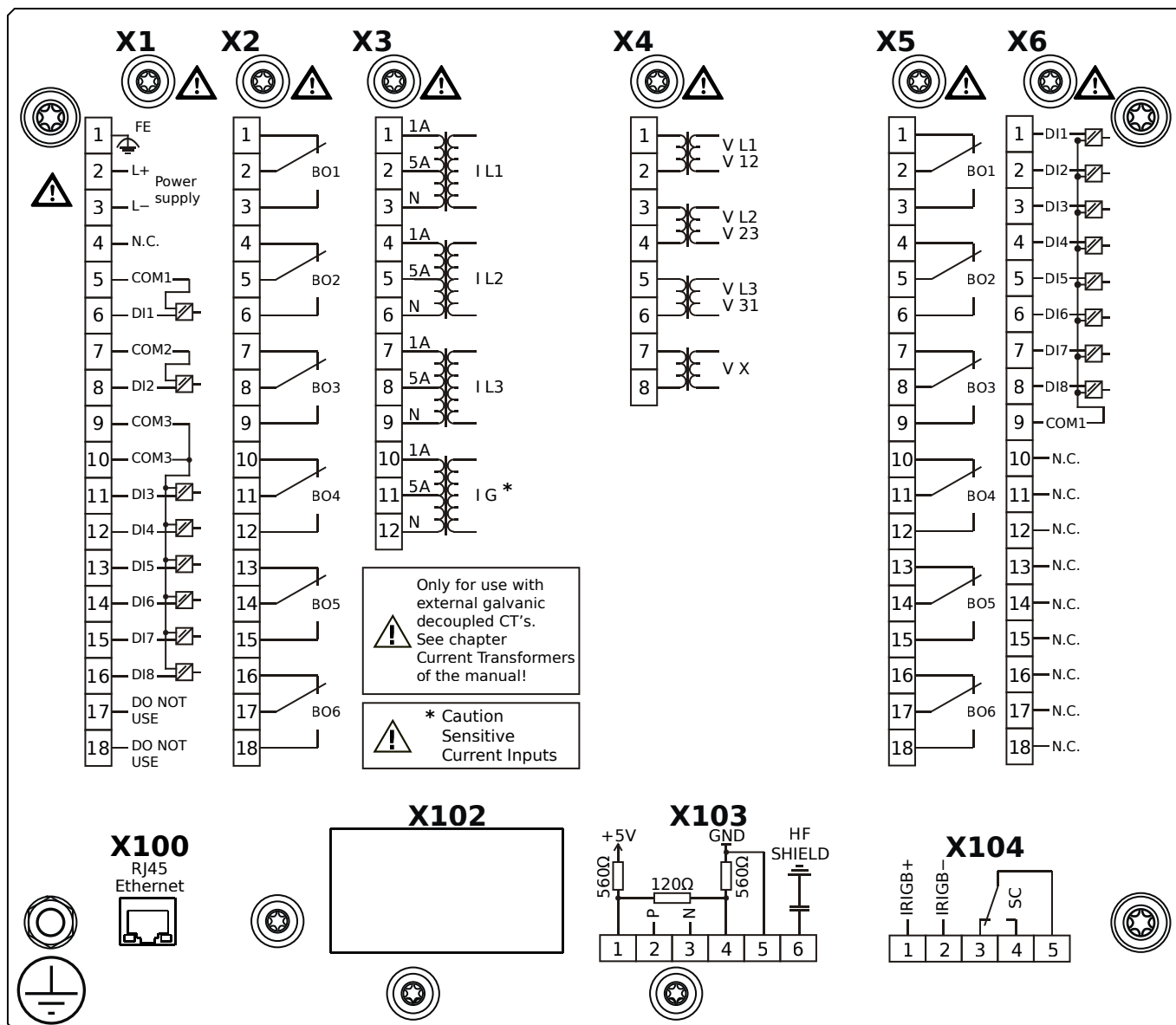

Housing B2, small display, 19" rack mounting

+ Conformal Coating (for installations in harsh environment)

- X1** – DI8-X1: Wide-range power supply unit, incl. 2 non-grouped digital inputs and 6 grouped digital inputs
- X2** – OR6: Assembly Group with 6 Output Relays (Changeover / Form C)
- X3** – TIs: Standard phase current measuring card and sensitive ground current measuring
- X4** – TU: Card with 4 voltage transformer measuring inputs (0 ... 800 VAC, under UL: 0 ... 600 VAC)
- X5** – OR6: Assembly Group with 6 Output Relays (Changeover / Form C)
- X6** – DI8: Assembly Group with 8 Digital Inputs
- X100** – Modbus TCP / DNP3.0 TCP/UDP, Ethernet interface, 100 Mbit/s, RJ45 (BASE100-FX)
- X103** – IEC 60870-5-103 / Modbus RTU / DNP3.0 RTU, RS485, Terminals
- X104** – IRIG-B00X, incl. System Contact (Supervision Contact)

MRA4-2D1BKA

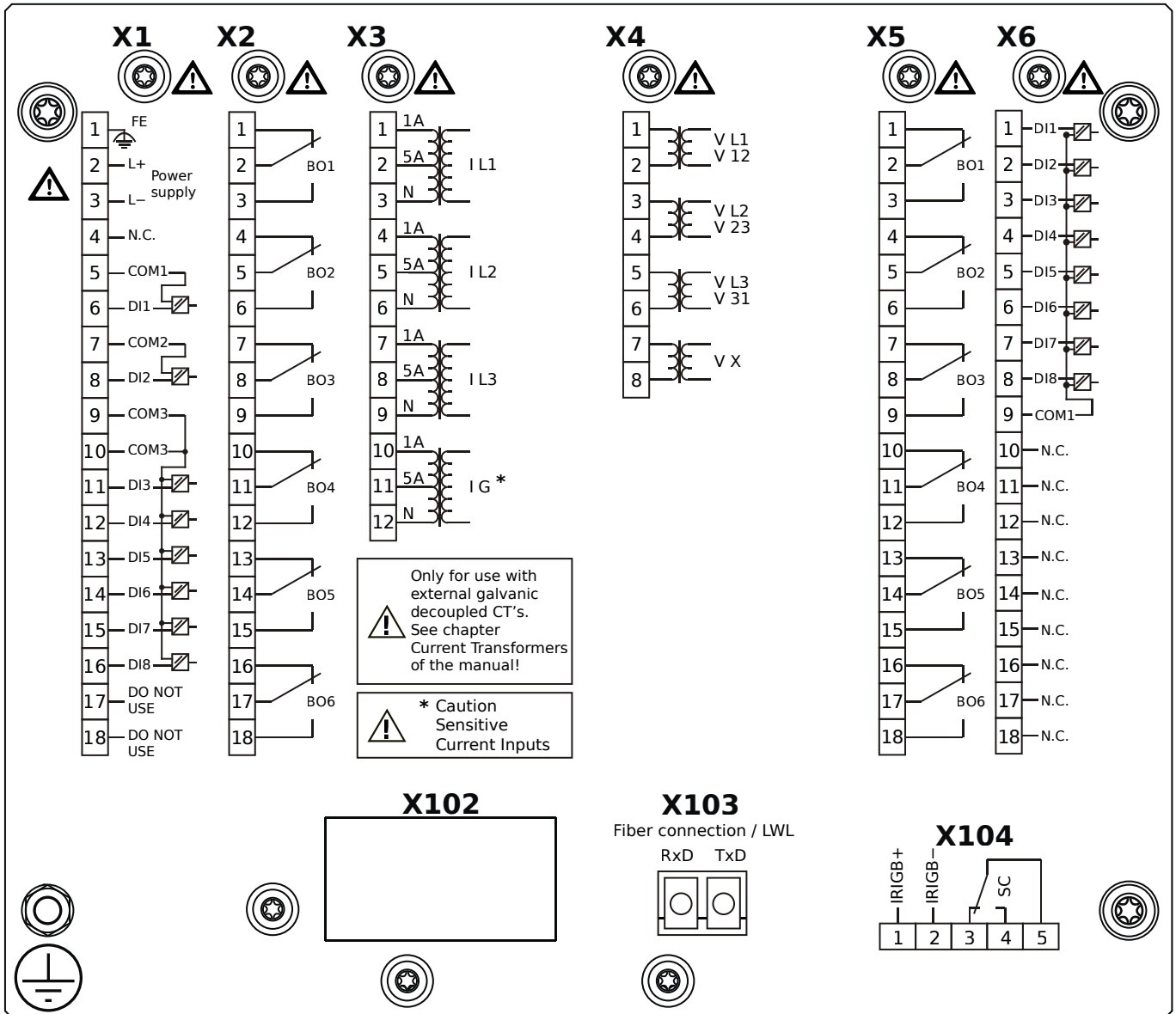

Housing B2, small display, 19" rack mounting

- X1** – DI8-X1: Wide-range power supply unit, incl. 2 non-grouped digital inputs and 6 grouped digital inputs
- X2** – OR6: Assembly Group with 6 Output Relays (Changeover / Form C)
- X3** – TIs: Standard phase current measuring card and sensitive ground current measuring
- X4** – TU: Card with 4 voltage transformer measuring inputs (0 ... 800 VAC, under UL: 0 ... 600 VAC)
- X5** – OR6: Assembly Group with 6 Output Relays (Changeover / Form C)
- X6** – DI8: Assembly Group with 8 Digital Inputs
- X103** – IEC 61850 / Modbus TCP / DNP3.0 TCP/UDP, Fiber optics interface, LC Connector
- X104** – IRIG-B00X, incl. System Contact (Supervision Contact)

MRA4-2D1BKB

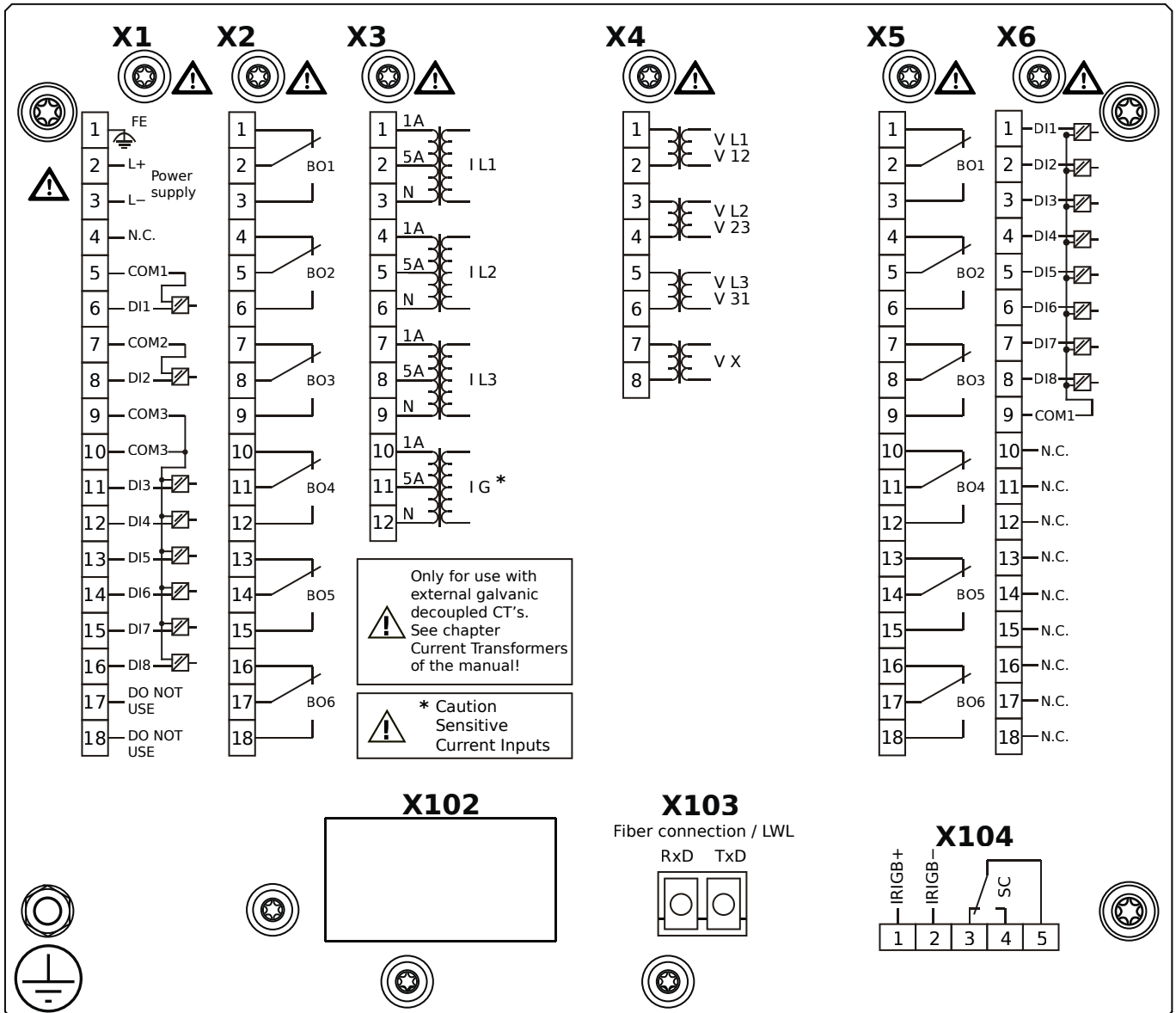

Housing B2, small display, 19" rack mounting

+ Conformal Coating (for installations in harsh environment)

- X1** – DI8-X1: Wide-range power supply unit, incl. 2 non-grouped digital inputs and 6 grouped digital inputs
- X2** – OR6: Assembly Group with 6 Output Relays (Changeover / Form C)
- X3** – TIs: Standard phase current measuring card and sensitive ground current measuring
- X4** – TU: Card with 4 voltage transformer measuring inputs (0 ... 800 VAC, under UL: 0 ... 600 VAC)
- X5** – OR6: Assembly Group with 6 Output Relays (Changeover / Form C)
- X6** – DI8: Assembly Group with 8 Digital Inputs
- X103** – IEC 61850 / Modbus TCP / DNP3.0 TCP/UDP, Fiber optics interface, LC Connector
- X104** – IRIG-B00X, incl. System Contact (Supervision Contact)

MRA4-2D1BLA

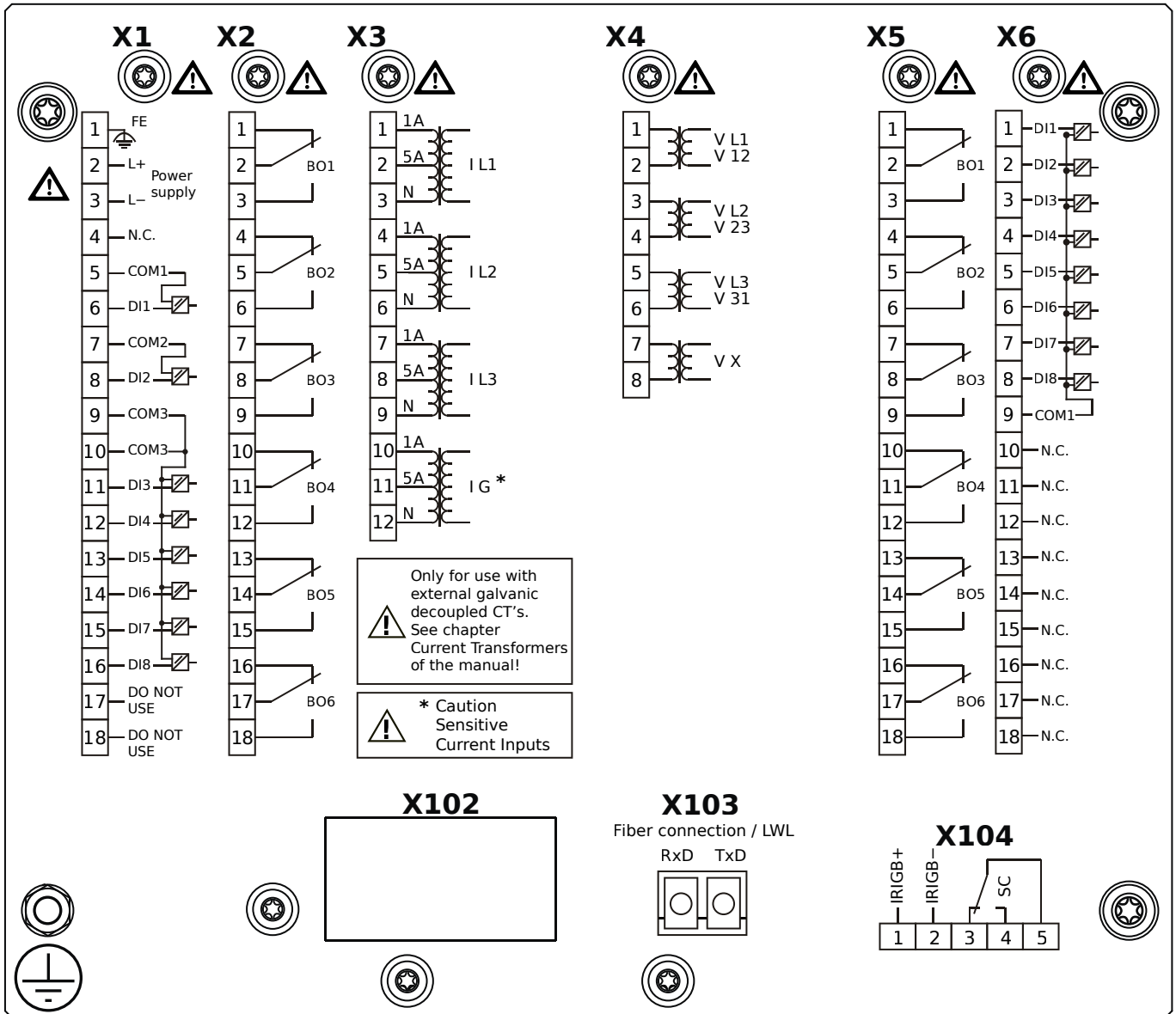

Housing B2, small display, 19" rack mounting

- X1** – DI8-X1: Wide-range power supply unit, incl. 2 non-grouped digital inputs and 6 grouped digital inputs
- X2** – OR6: Assembly Group with 6 Output Relays (Changeover / Form C)
- X3** – TIs: Standard phase current measuring card and sensitive ground current measuring
- X4** – TU: Card with 4 voltage transformer measuring inputs (0 ... 800 VAC, under UL: 0 ... 600 VAC)
- X5** – OR6: Assembly Group with 6 Output Relays (Changeover / Form C)
- X6** – DI8: Assembly Group with 8 Digital Inputs
- X103** – Modbus TCP / DNP3.0 TCP/UDP, Fiber optics interface, LC Connector
- X104** – IRIG-B00X, incl. System Contact (Supervision Contact)

MRA4-2D1BLB

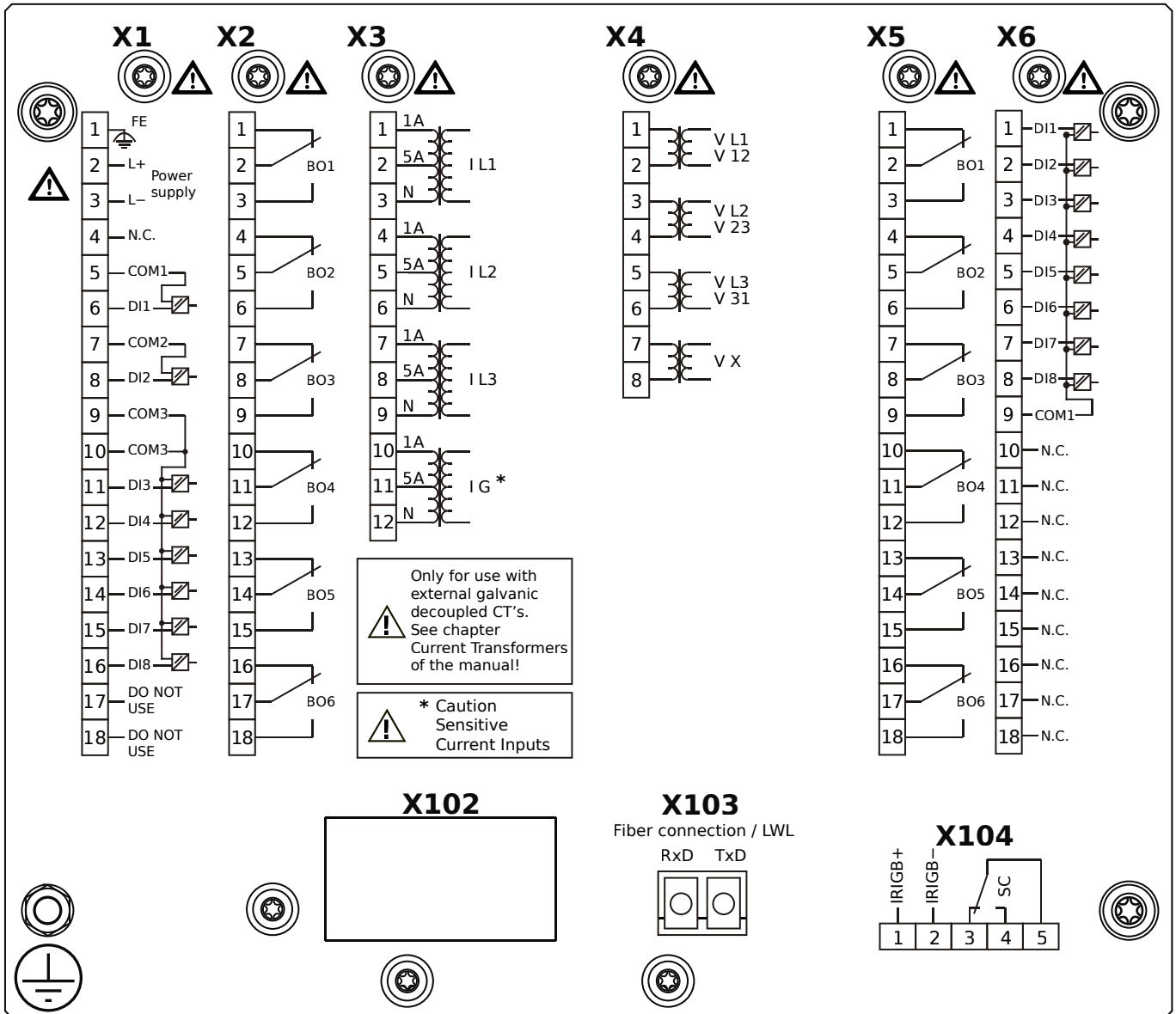

Housing B2, small display, 19" rack mounting

+ Conformal Coating (for installations in harsh environment)

- X1** – DI8-X1: Wide-range power supply unit, incl. 2 non-grouped digital inputs and 6 grouped digital inputs
- X2** – OR6: Assembly Group with 6 Output Relays (Changeover / Form C)
- X3** – TIs: Standard phase current measuring card and sensitive ground current measuring
- X4** – TU: Card with 4 voltage transformer measuring inputs (0 ... 800 VAC, under UL: 0 ... 600 VAC)
- X5** – OR6: Assembly Group with 6 Output Relays (Changeover / Form C)
- X6** – DI8: Assembly Group with 8 Digital Inputs
- X103** – Modbus TCP / DNP3.0 TCP/UDP, Fiber optics interface, LC Connector
- X104** – IRIG-B00X, incl. System Contact (Supervision Contact)

MRA4-2D1BTA

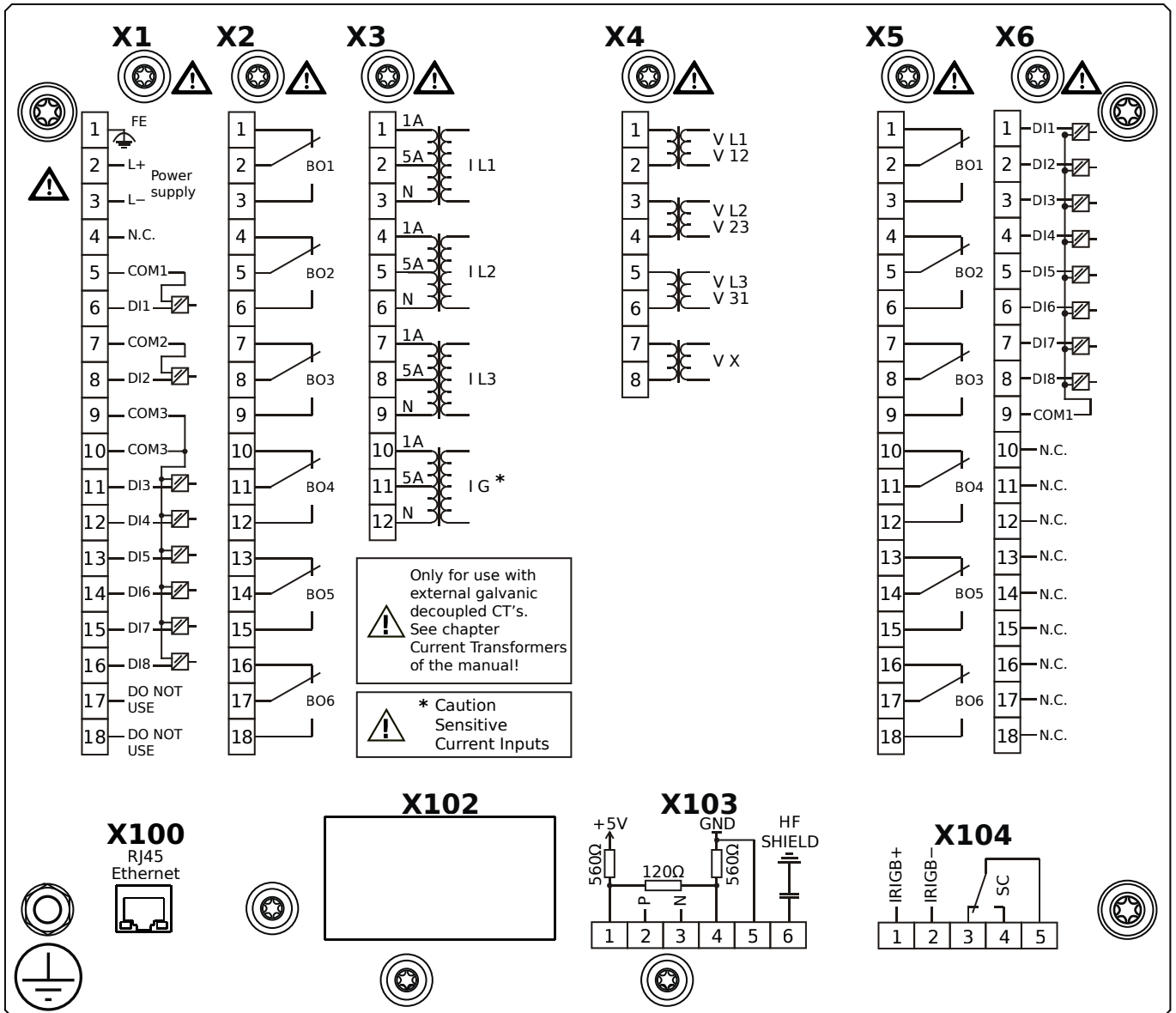

Housing B2, small display, 19" rack mounting

- X1** – DI8-X1: Wide-range power supply unit, incl. 2 non-grouped digital inputs and 6 grouped digital inputs
- X2** – OR6: Assembly Group with 6 Output Relays (Changeover / Form C)
- X3** – TIs: Standard phase current measuring card and sensitive ground current measuring
- X4** – TU: Card with 4 voltage transformer measuring inputs (0 ... 800 VAC, under UL: 0 ... 600 VAC)
- X5** – OR6: Assembly Group with 6 Output Relays (Changeover / Form C)
- X6** – DI8: Assembly Group with 8 Digital Inputs
- X100** – IEC 61850 / Modbus TCP / DNP3.0 TCP/UDP, Ethernet interface, 100 Mbit/s, RJ45 (BASE100-FX)
- X103** – IEC 60870-5-103 / Modbus RTU / DNP3.0 RTU, RS485, Terminals
- X104** – IRIG-B00X, incl. System Contact (Supervision Contact)

MRA4-2D1BTB

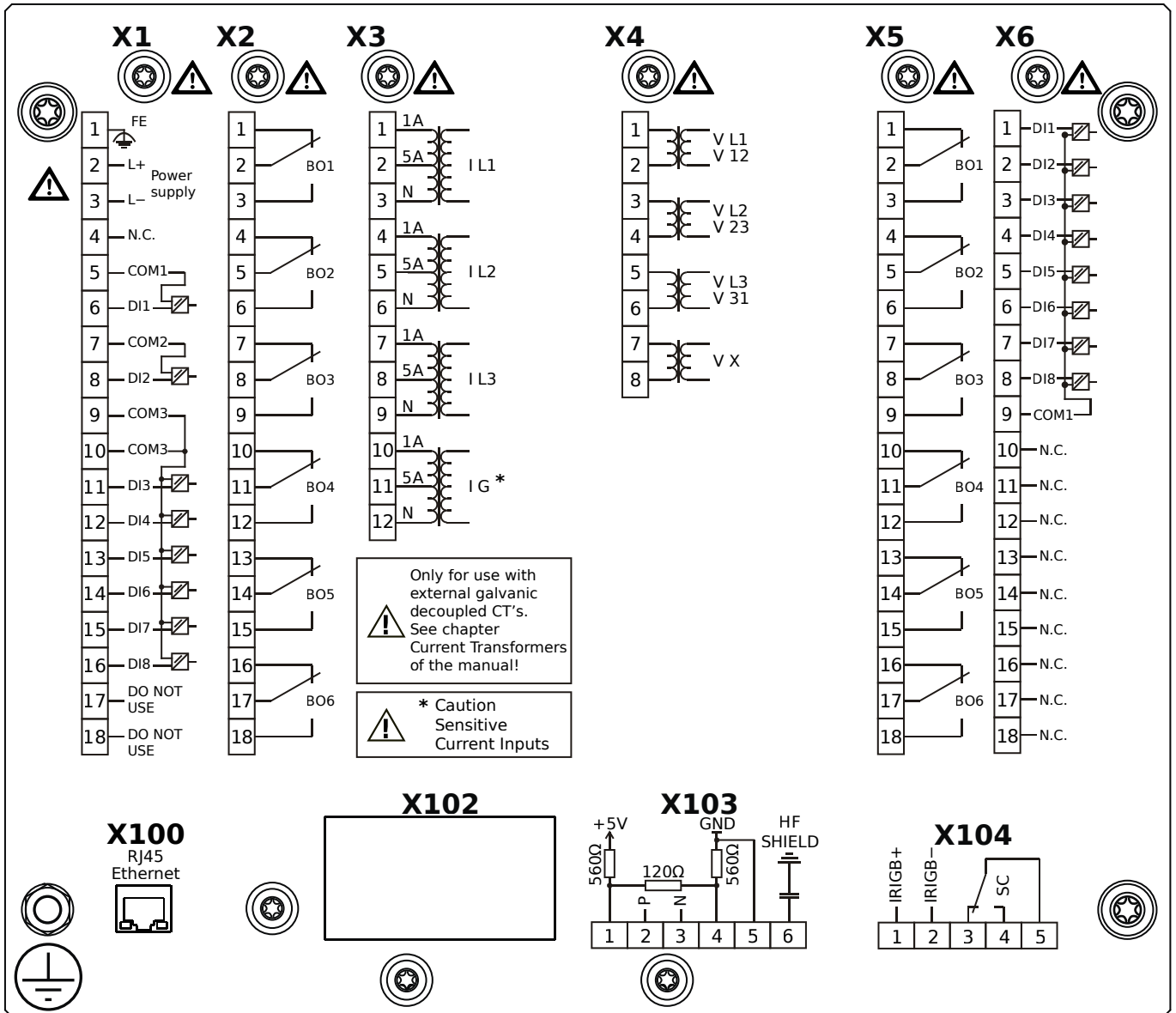

Housing B2, small display, 19" rack mounting

+ Conformal Coating (for installations in harsh environment)

- X1** – DI8-X1: Wide-range power supply unit, incl. 2 non-grouped digital inputs and 6 grouped digital inputs
- X2** – OR6: Assembly Group with 6 Output Relays (Changeover / Form C)
- X3** – TIs: Standard phase current measuring card and sensitive ground current measuring
- X4** – TU: Card with 4 voltage transformer measuring inputs (0 ... 800 VAC, under UL: 0 ... 600 VAC)
- X5** – OR6: Assembly Group with 6 Output Relays (Changeover / Form C)
- X6** – DI8: Assembly Group with 8 Digital Inputs
- X100** – IEC 61850 / Modbus TCP / DNP3.0 TCP/UDP, Ethernet interface, 100 Mbit/s, RJ45 (BASE100-FX)
- X103** – IEC 60870-5-103 / Modbus RTU / DNP3.0 RTU, RS485, Terminals
- X104** – IRIG-B00X, incl. System Contact (Supervision Contact)

MRA4-2E0AAA

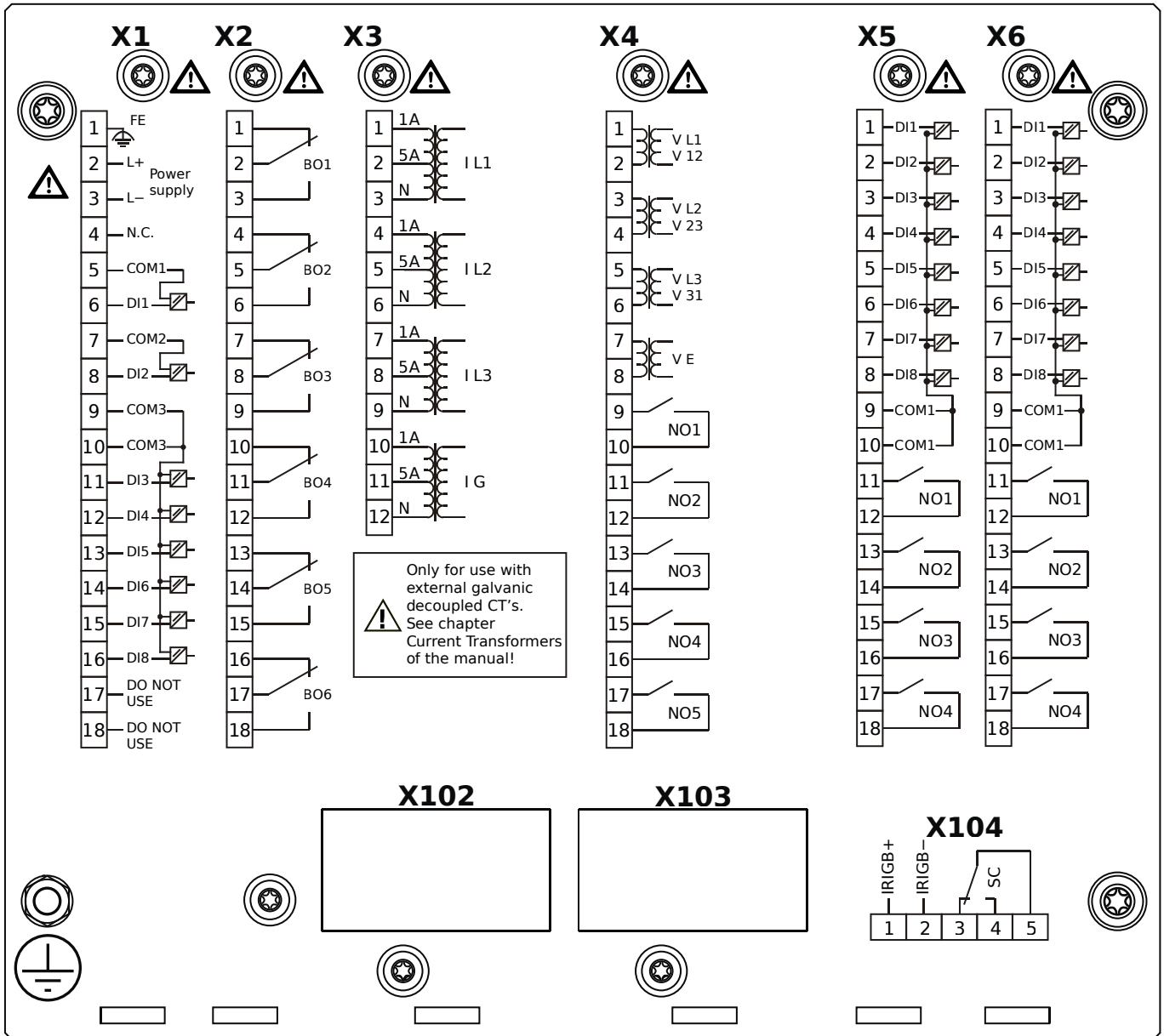

Housing B2, small display, door mounting

- X1** – DI8-X1: Wide-range power supply unit, incl. 2 non-grouped digital inputs and 6 grouped digital inputs
- X2** – OR6: Assembly Group with 6 Output Relays (Changeover / Form C)
- X3** – TI: Standard current measuring card
- X4** – TU-OR5: Voltage measuring (0 ... 300 VAC) assembly group with 5 additional Output Relays (NO / Form A)
- X5** – DI8-OR4: Assembly Group with 8 Digital Inputs and 4 Output Relays (NO / Form A)
- X6** – DI8-OR4: Assembly Group with 8 Digital Inputs and 4 Output Relays (NO / Form A)
- X104** – IRIG-B00X, incl. System Contact (Supervision Contact)

MRA4-2E0AAB

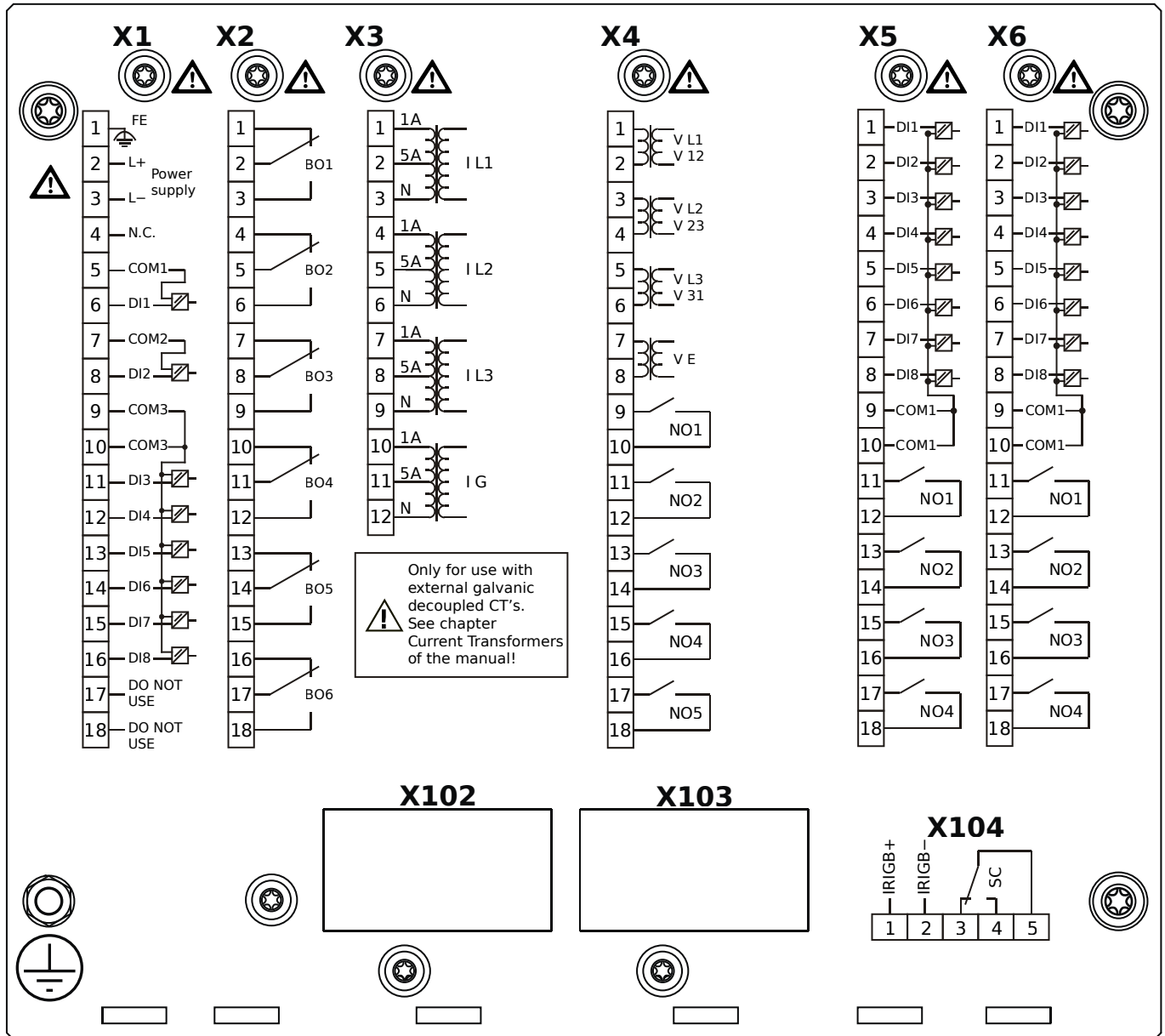

Housing B2, small display, door mounting

+ Conformal Coating (for installations in harsh environment)

- X1** – DI8-X1: Wide-range power supply unit, incl. 2 non-grouped digital inputs and 6 grouped digital inputs
- X2** – OR6: Assembly Group with 6 Output Relays (Changeover / Form C)
- X3** – TI: Standard current measuring card
- X4** – TU-OR5: Voltage measuring (0 ... 300 VAC) assembly group with 5 additional Output Relays (NO / Form A)
- X5** – DI8-OR4: Assembly Group with 8 Digital Inputs and 4 Output Relays (NO / Form A)
- X6** – DI8-OR4: Assembly Group with 8 Digital Inputs and 4 Output Relays (NO / Form A)
- X104** – IRIG-B00X, incl. System Contact (Supervision Contact)

MRA4-2E0ABA

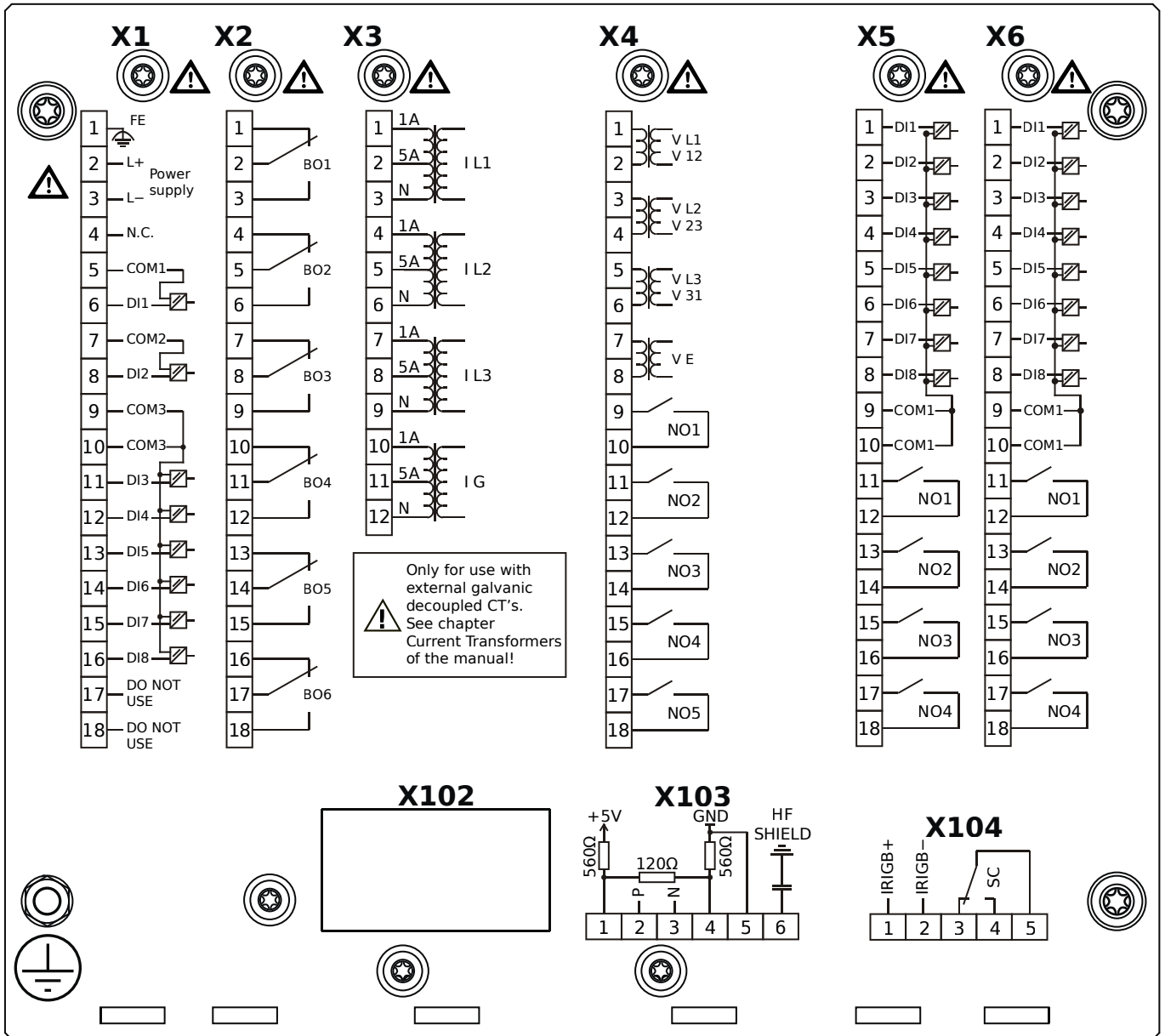

Housing B2, small display, door mounting

- X1** – DI8-X1: Wide-range power supply unit, incl. 2 non-grouped digital inputs and 6 grouped digital inputs
- X2** – OR6: Assembly Group with 6 Output Relays (Changeover / Form C)
- X3** – TI: Standard current measuring card
- X4** – TU-OR5: Voltage measuring (0 ... 300 VAC) assembly group with 5 additional Output Relays (NO / Form A)
- X5** – DI8-OR4: Assembly Group with 8 Digital Inputs and 4 Output Relays (NO / Form A)
- X6** – DI8-OR4: Assembly Group with 8 Digital Inputs and 4 Output Relays (NO / Form A)
- X103** – Modbus RTU / IEC 60870-5-103 / DNP3.0 RTU, RS485, Terminals
- X104** – IRIG-B00X, incl. System Contact (Supervision Contact)

MRA4-2E0ABB

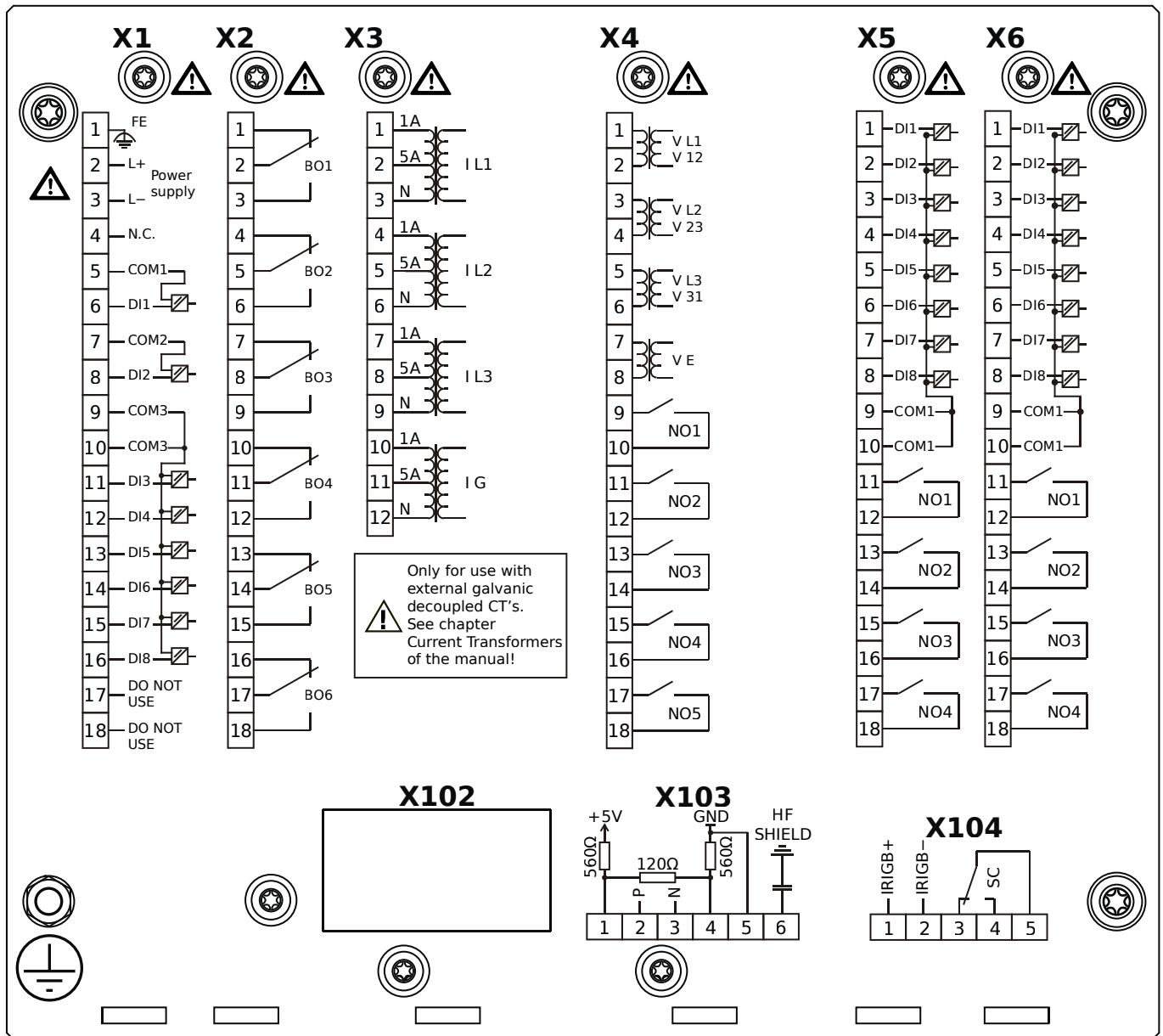

Housing B2, small display, door mounting

+ Conformal Coating (for installations in harsh environment)

- X1** – DI8-X1: Wide-range power supply unit, incl. 2 non-grouped digital inputs and 6 grouped digital inputs
- X2** – OR6: Assembly Group with 6 Output Relays (Changeover / Form C)
- X3** – TI: Standard current measuring card
- X4** – TU-OR5: Voltage measuring (0 ... 300 VAC) assembly group with 5 additional Output Relays (NO / Form A)
- X5** – DI8-OR4: Assembly Group with 8 Digital Inputs and 4 Output Relays (NO / Form A)
- X6** – DI8-OR4: Assembly Group with 8 Digital Inputs and 4 Output Relays (NO / Form A)
- X103** – Modbus RTU / IEC 60870-5-103 / DNP3.0 RTU, RS485, Terminals
- X104** – IRIG-B00X, incl. System Contact (Supervision Contact)

MRA4-2E0ACA

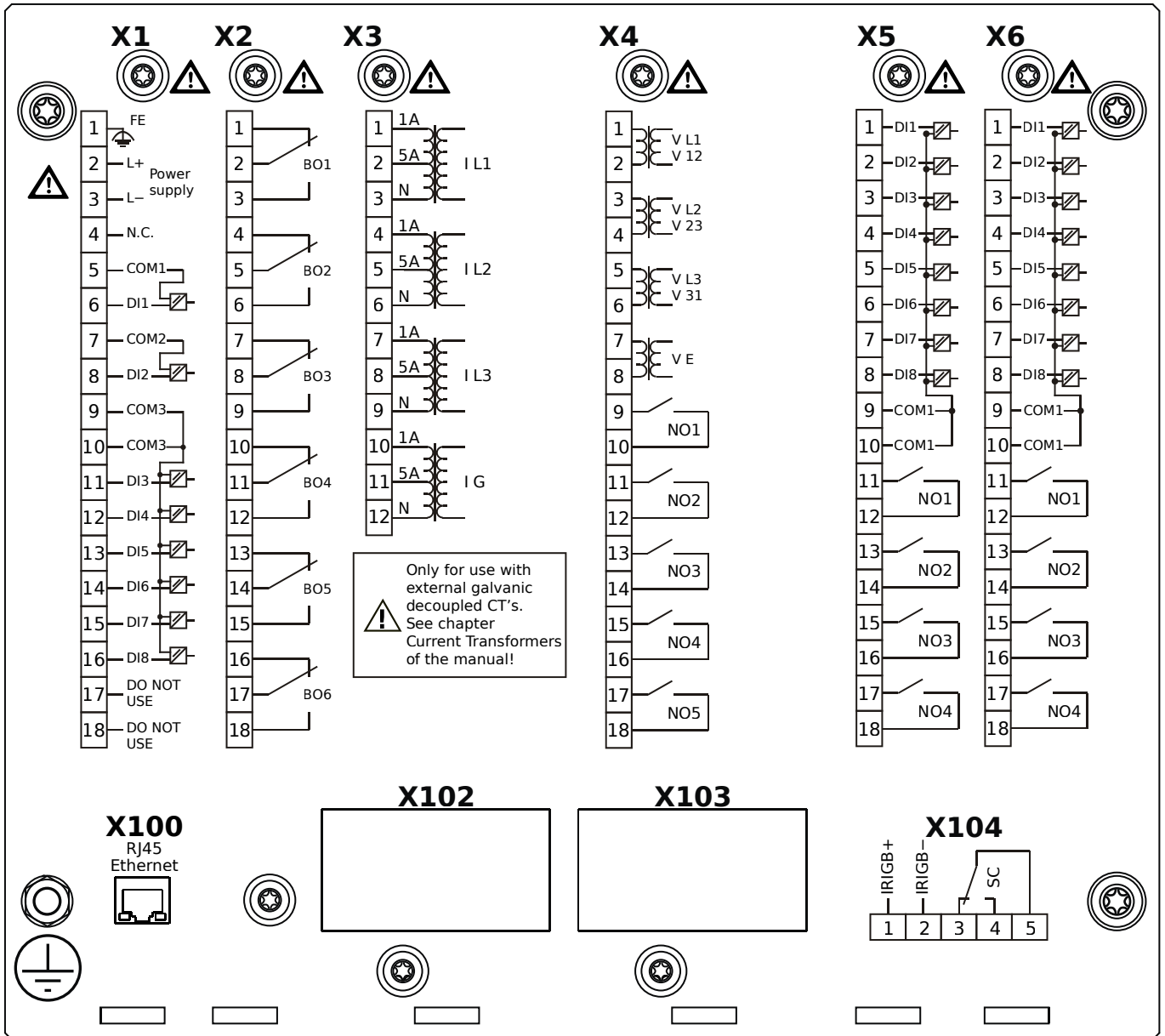

Housing B2, small display, door mounting

- X1** – DI8-X1: Wide-range power supply unit, incl. 2 non-grouped digital inputs and 6 grouped digital inputs
- X2** – OR6: Assembly Group with 6 Output Relays (Changeover / Form C)
- X3** – TI: Standard current measuring card
- X4** – TU-OR5: Voltage measuring (0 ... 300 VAC) assembly group with 5 additional Output Relays (NO / Form A)
- X5** – DI8-OR4: Assembly Group with 8 Digital Inputs and 4 Output Relays (NO / Form A)
- X6** – DI8-OR4: Assembly Group with 8 Digital Inputs and 4 Output Relays (NO / Form A)
- X100** – Modbus TCP / DNP3.0 TCP/UDP, Ethernet interface, 100 Mbit/s, RJ45 (BASE100-FX)
- X104** – IRIG-B00X, incl. System Contact (Supervision Contact)

MRA4-2E0ACB

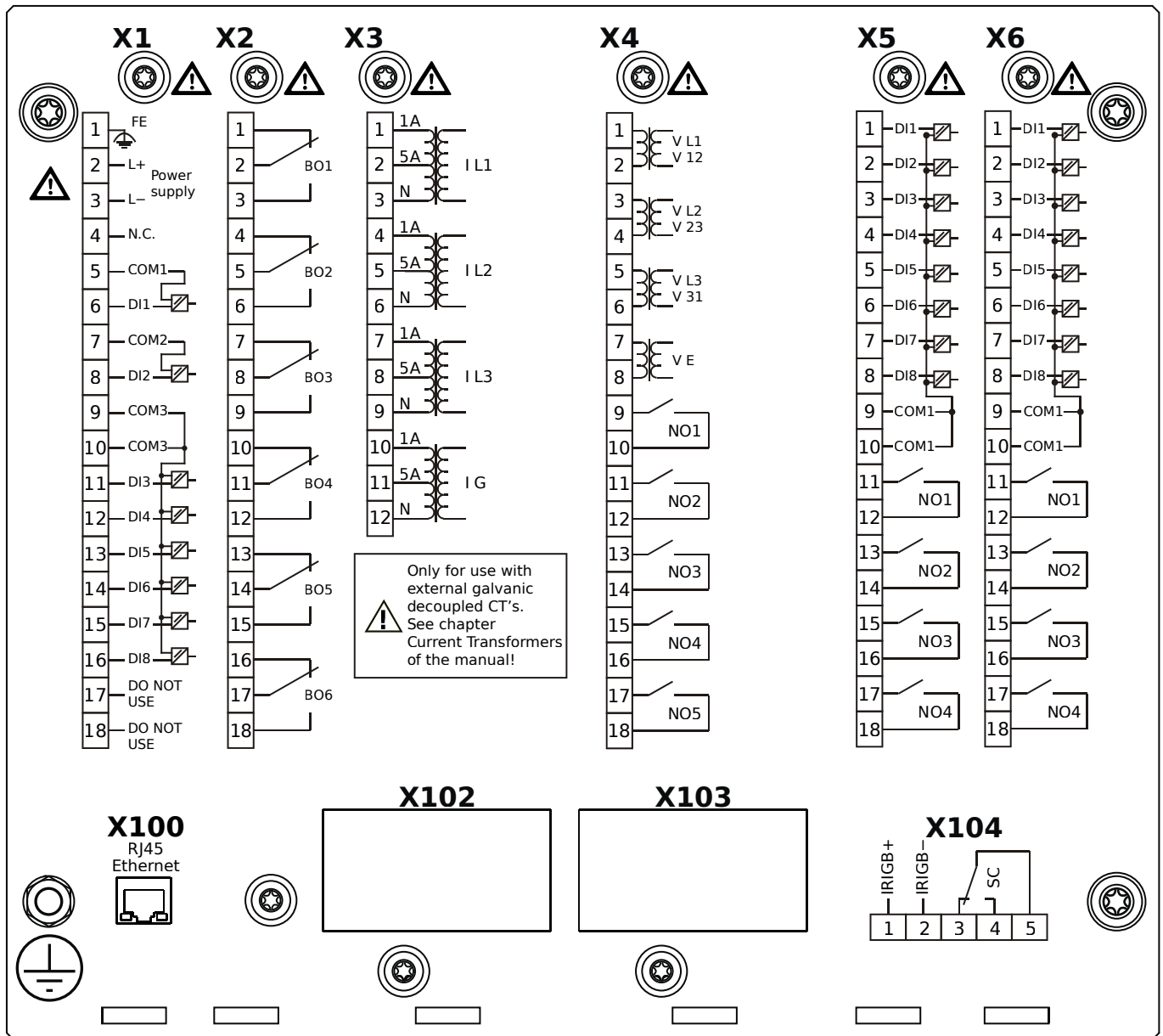

Housing B2, small display, door mounting

+ Conformal Coating (for installations in harsh environment)

- X1** – DI8-X1: Wide-range power supply unit, incl. 2 non-grouped digital inputs and 6 grouped digital inputs
- X2** – OR6: Assembly Group with 6 Output Relays (Changeover / Form C)
- X3** – TI: Standard current measuring card
- X4** – TU-OR5: Voltage measuring (0 ... 300 VAC) assembly group with 5 additional Output Relays (NO / Form A)
- X5** – DI8-OR4: Assembly Group with 8 Digital Inputs and 4 Output Relays (NO / Form A)
- X6** – DI8-OR4: Assembly Group with 8 Digital Inputs and 4 Output Relays (NO / Form A)
- X100** – Modbus TCP / DNP3.0 TCP/UDP, Ethernet interface, 100 Mbit/s, RJ45 (BASE100-FX)
- X104** – IRIG-B00X, incl. System Contact (Supervision Contact)

MRA4-2E0ADA

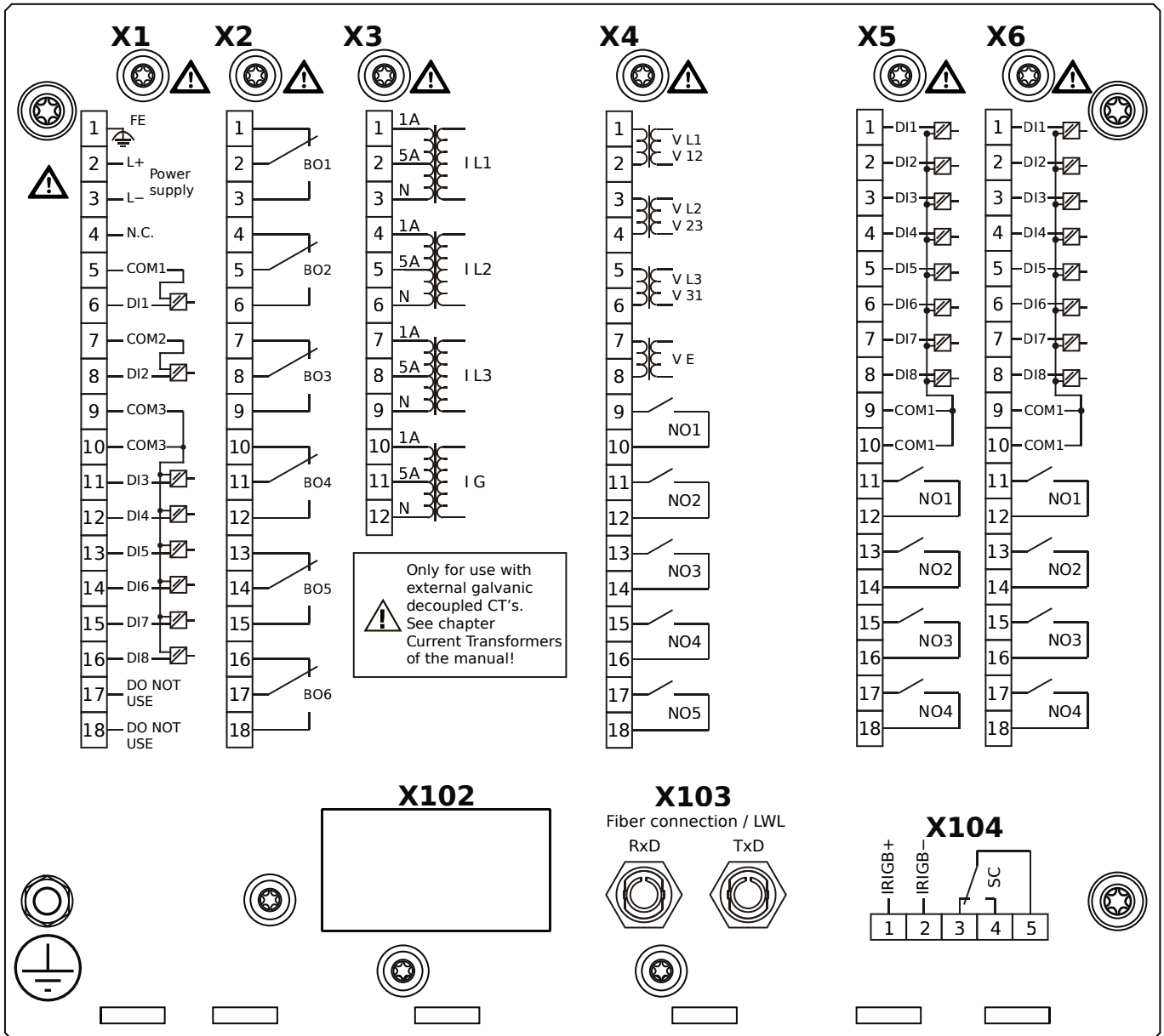

Housing B2, small display, door mounting

- X1** – DI8-X1: Wide-range power supply unit, incl. 2 non-grouped digital inputs and 6 grouped digital inputs
- X2** – OR6: Assembly Group with 6 Output Relays (Changeover / Form C)
- X3** – TI: Standard current measuring card
- X4** – TU-OR5: Voltage measuring (0 ... 300 VAC) assembly group with 5 additional Output Relays (NO / Form A)
- X5** – DI8-OR4: Assembly Group with 8 Digital Inputs and 4 Output Relays (NO / Form A)
- X6** – DI8-OR4: Assembly Group with 8 Digital Inputs and 4 Output Relays (NO / Form A)
- X103** – Profibus-DP, Fiber optics interface, ST Connector
- X104** – IRIG-B00X, incl. System Contact (Supervision Contact)

MRA4-2E0ADB

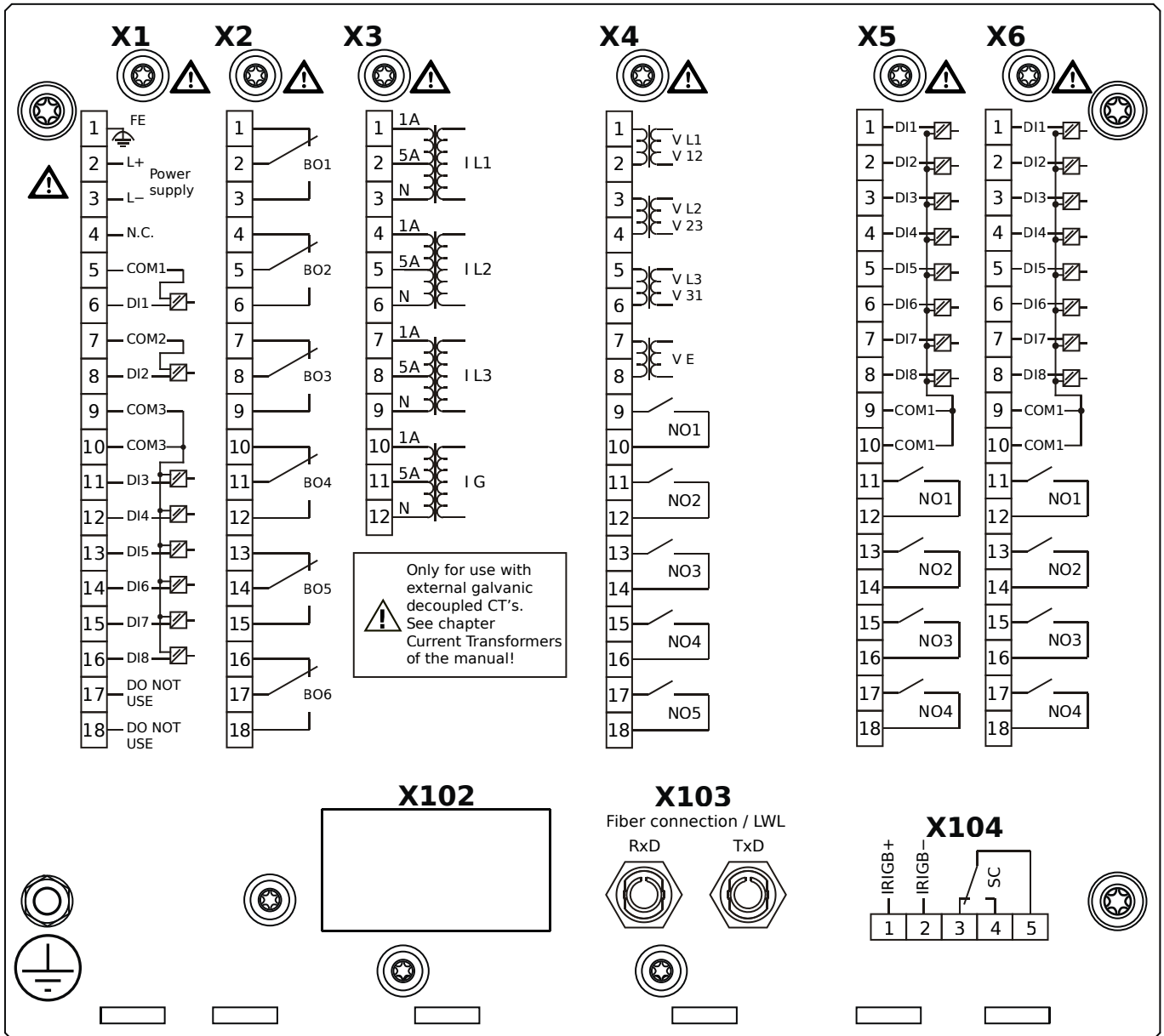

Housing B2, small display, door mounting

- + Conformal Coating (for installations in harsh environment)

- X1** – DI8-X1: Wide-range power supply unit, incl. 2 non-grouped digital inputs and 6 grouped digital inputs
- X2** – OR6: Assembly Group with 6 Output Relays (Changeover / Form C)
- X3** – TI: Standard current measuring card
- X4** – TU-OR5: Voltage measuring (0 ... 300 VAC) assembly group with 5 additional Output Relays (NO / Form A)
- X5** – DI8-OR4: Assembly Group with 8 Digital Inputs and 4 Output Relays (NO / Form A)
- X6** – DI8-OR4: Assembly Group with 8 Digital Inputs and 4 Output Relays (NO / Form A)
- X103** – Profibus-DP, Fiber optics interface, ST Connector
- X104** – IRIG-B00X, incl. System Contact (Supervision Contact)

MRA4-2E0AEA

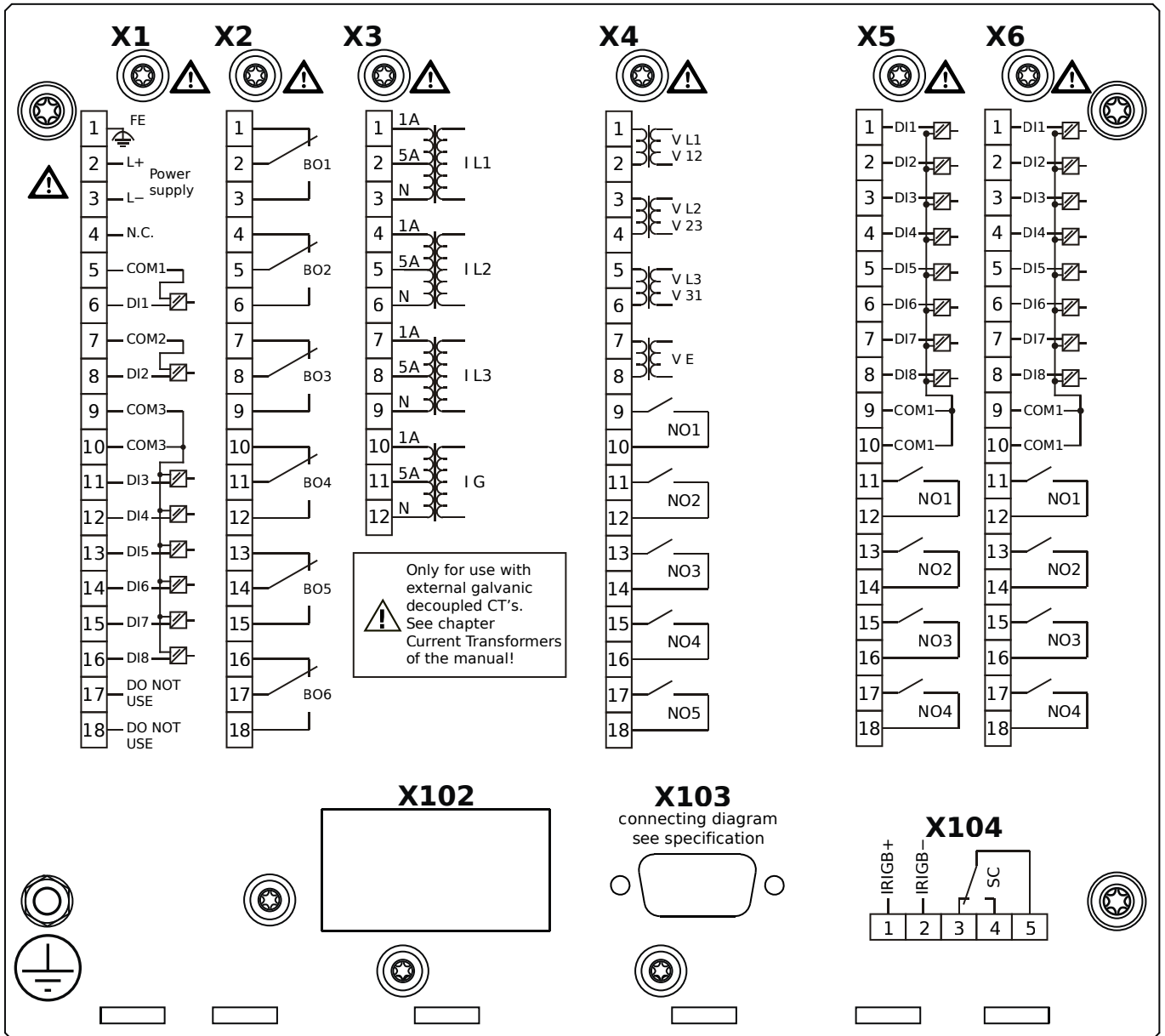

Housing B2, small display, door mounting

- X1** – DI8-X1: Wide-range power supply unit, incl. 2 non-grouped digital inputs and 6 grouped digital inputs
- X2** – OR6: Assembly Group with 6 Output Relays (Changeover / Form C)
- X3** – TI: Standard current measuring card
- X4** – TU-OR5: Voltage measuring (0 ... 300 VAC) assembly group with 5 additional Output Relays (NO / Form A)
- X5** – DI8-OR4: Assembly Group with 8 Digital Inputs and 4 Output Relays (NO / Form A)
- X6** – DI8-OR4: Assembly Group with 8 Digital Inputs and 4 Output Relays (NO / Form A)
- X103** – Profibus-DP, RS485, D-SUB
- X104** – IRIG-B00X, incl. System Contact (Supervision Contact)

MRA4-2E0AEB

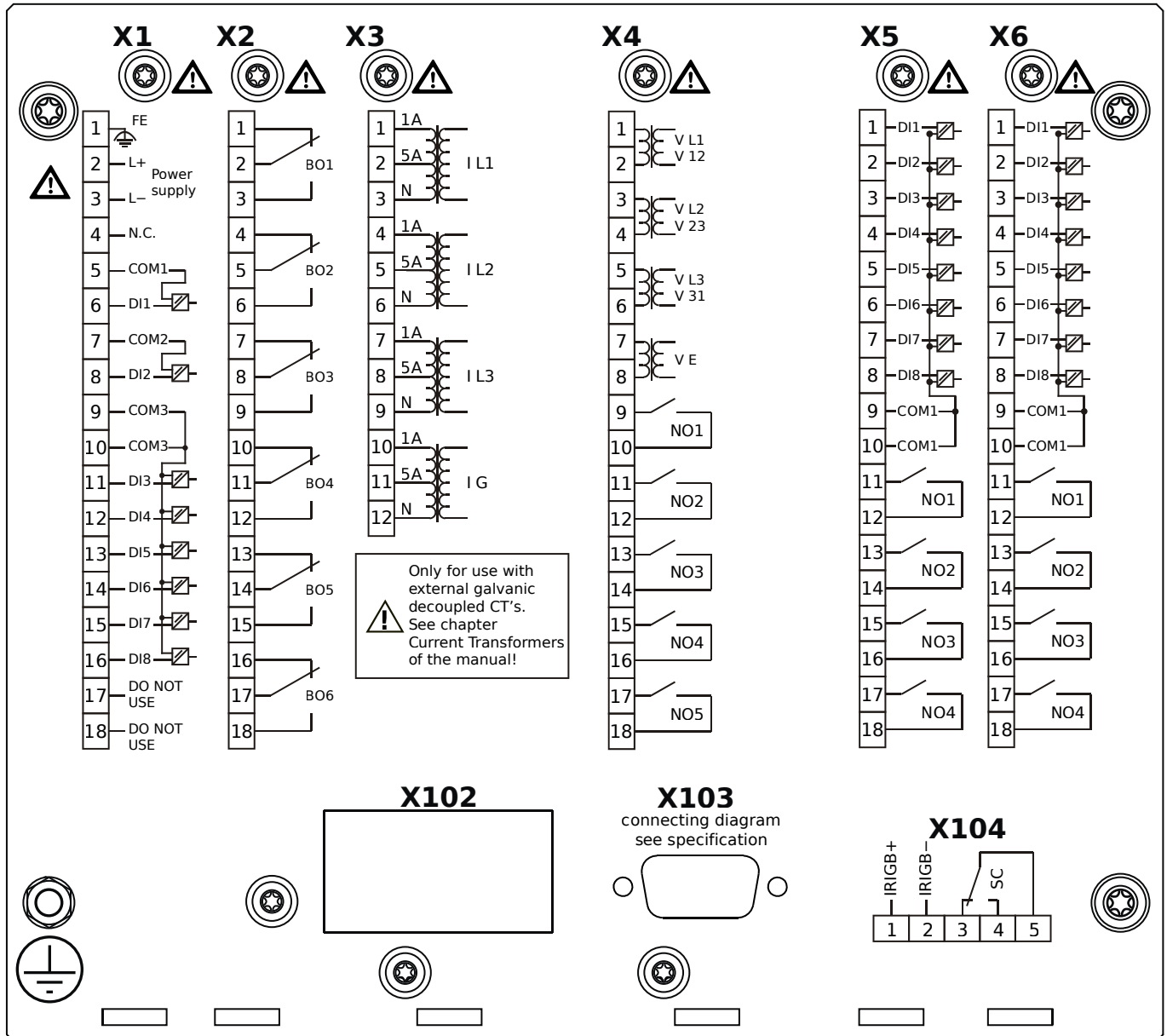

Housing B2, small display, door mounting

+ Conformal Coating (for installations in harsh environment)

- X1** – DI8-X1: Wide-range power supply unit, incl. 2 non-grouped digital inputs and 6 grouped digital inputs
- X2** – OR6: Assembly Group with 6 Output Relays (Changeover / Form C)
- X3** – TI: Standard current measuring card
- X4** – TU-OR5: Voltage measuring (0 ... 300 VAC) assembly group with 5 additional Output Relays (NO / Form A)
- X5** – DI8-OR4: Assembly Group with 8 Digital Inputs and 4 Output Relays (NO / Form A)
- X6** – DI8-OR4: Assembly Group with 8 Digital Inputs and 4 Output Relays (NO / Form A)
- X103** – Profibus-DP, RS485, D-SUB
- X104** – IRIG-B00X, incl. System Contact (Supervision Contact)

MRA4-2E0AFA

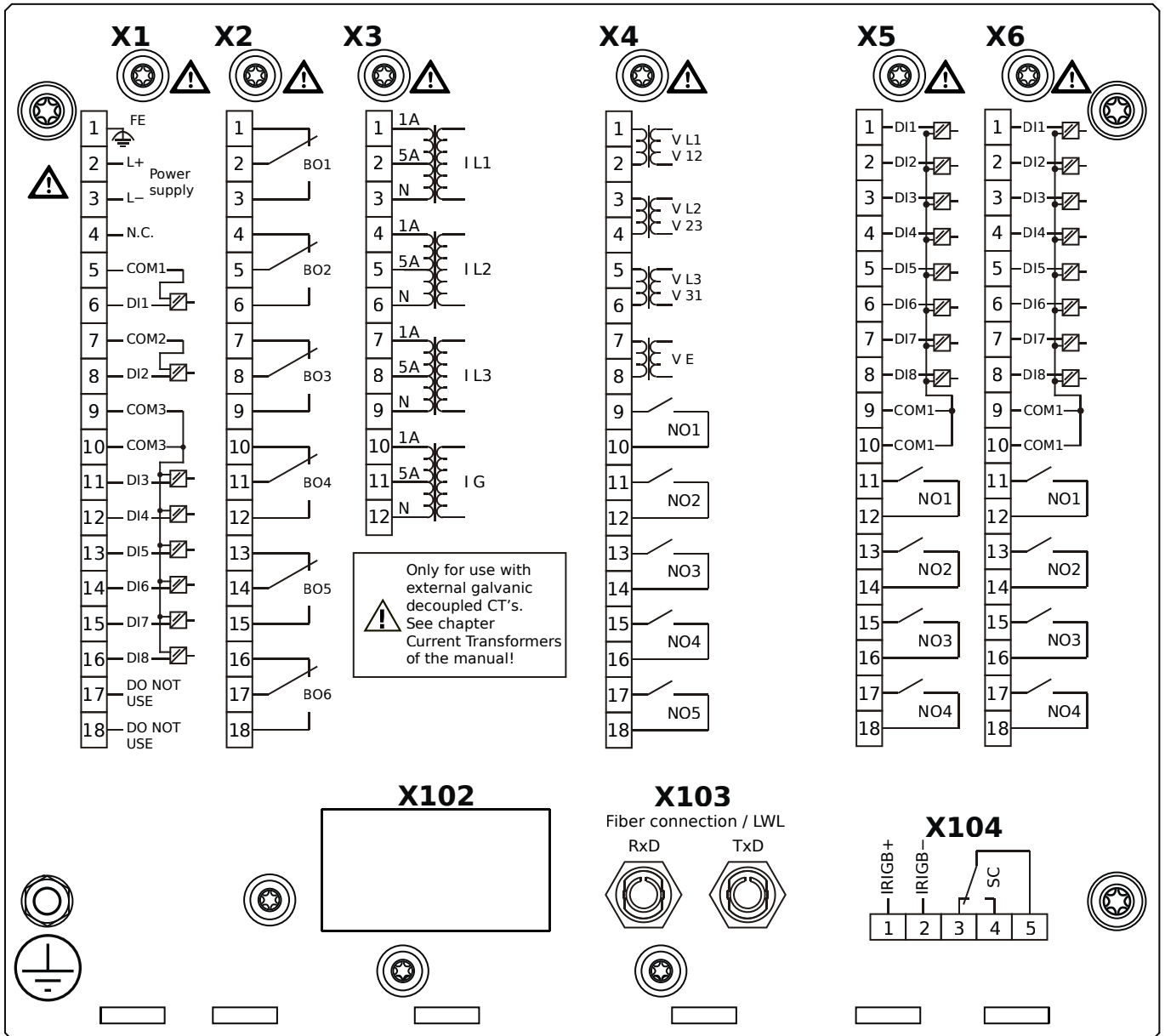

Housing B2, small display, door mounting

- X1** – DI8-X1: Wide-range power supply unit, incl. 2 non-grouped digital inputs and 6 grouped digital inputs
- X2** – OR6: Assembly Group with 6 Output Relays (Changeover / Form C)
- X3** – TI: Standard current measuring card
- X4** – TU-OR5: Voltage measuring (0 ... 300 VAC) assembly group with 5 additional Output Relays (NO / Form A)
- X5** – DI8-OR4: Assembly Group with 8 Digital Inputs and 4 Output Relays (NO / Form A)
- X6** – DI8-OR4: Assembly Group with 8 Digital Inputs and 4 Output Relays (NO / Form A)
- X103** – Modbus RTU / IEC 60870-5-103 / DNP3.0 RTU, Fiber optics interface, ST Connector
- X104** – IRIG-B00X, incl. System Contact (Supervision Contact)

MRA4-2E0AFB

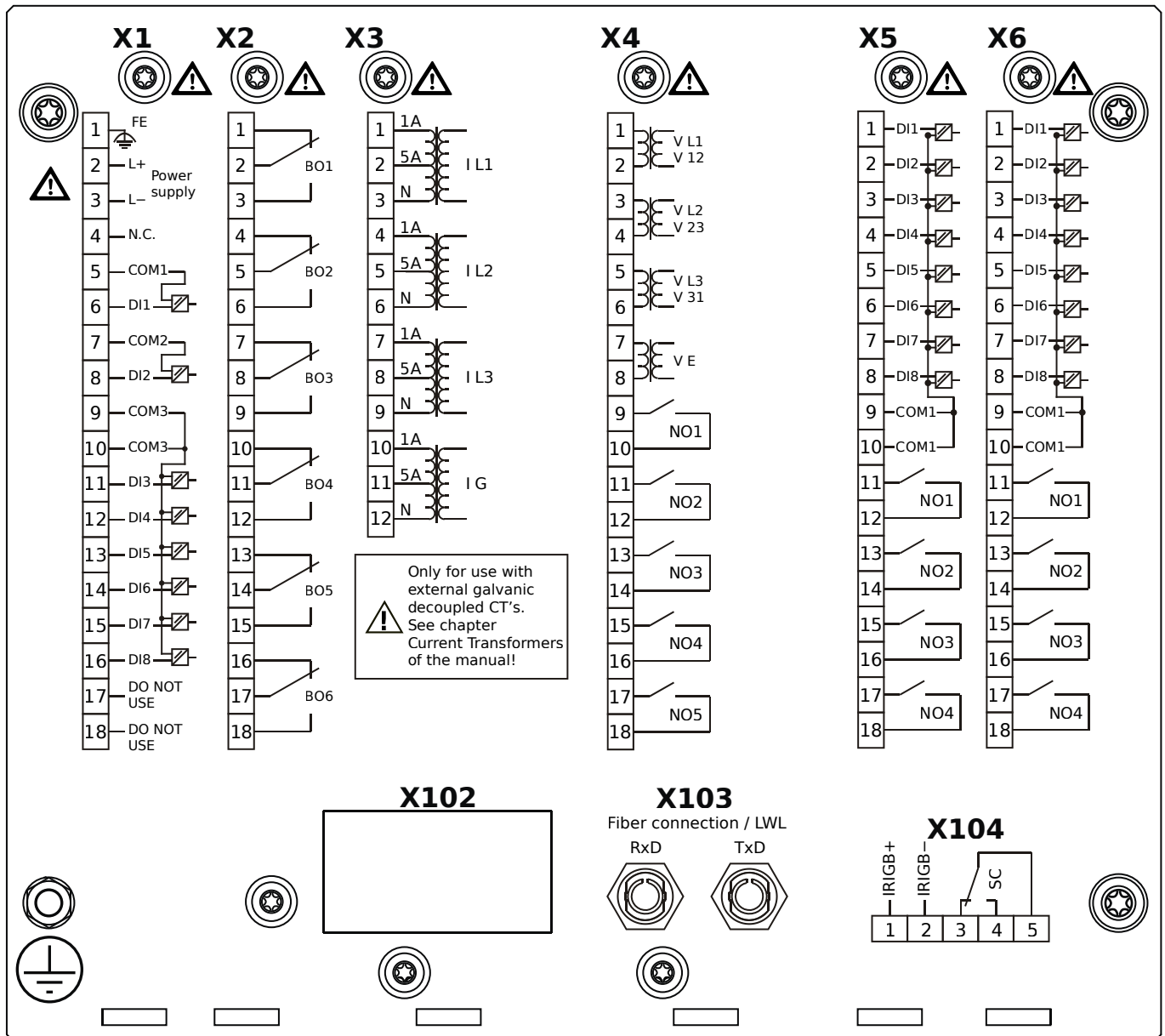

Housing B2, small display, door mounting

+ Conformal Coating (for installations in harsh environment)

- X1** – DI8-X1: Wide-range power supply unit, incl. 2 non-grouped digital inputs and 6 grouped digital inputs
- X2** – OR6: Assembly Group with 6 Output Relays (Changeover / Form C)
- X3** – TI: Standard current measuring card
- X4** – TU-OR5: Voltage measuring (0 ... 300 VAC) assembly group with 5 additional Output Relays (NO / Form A)
- X5** – DI8-OR4: Assembly Group with 8 Digital Inputs and 4 Output Relays (NO / Form A)
- X6** – DI8-OR4: Assembly Group with 8 Digital Inputs and 4 Output Relays (NO / Form A)
- X103** – Modbus RTU / IEC 60870-5-103 / DNP3.0 RTU, Fiber optics interface, ST Connector
- X104** – IRIG-B00X, incl. System Contact (Supervision Contact)

MRA4-2E0AGA

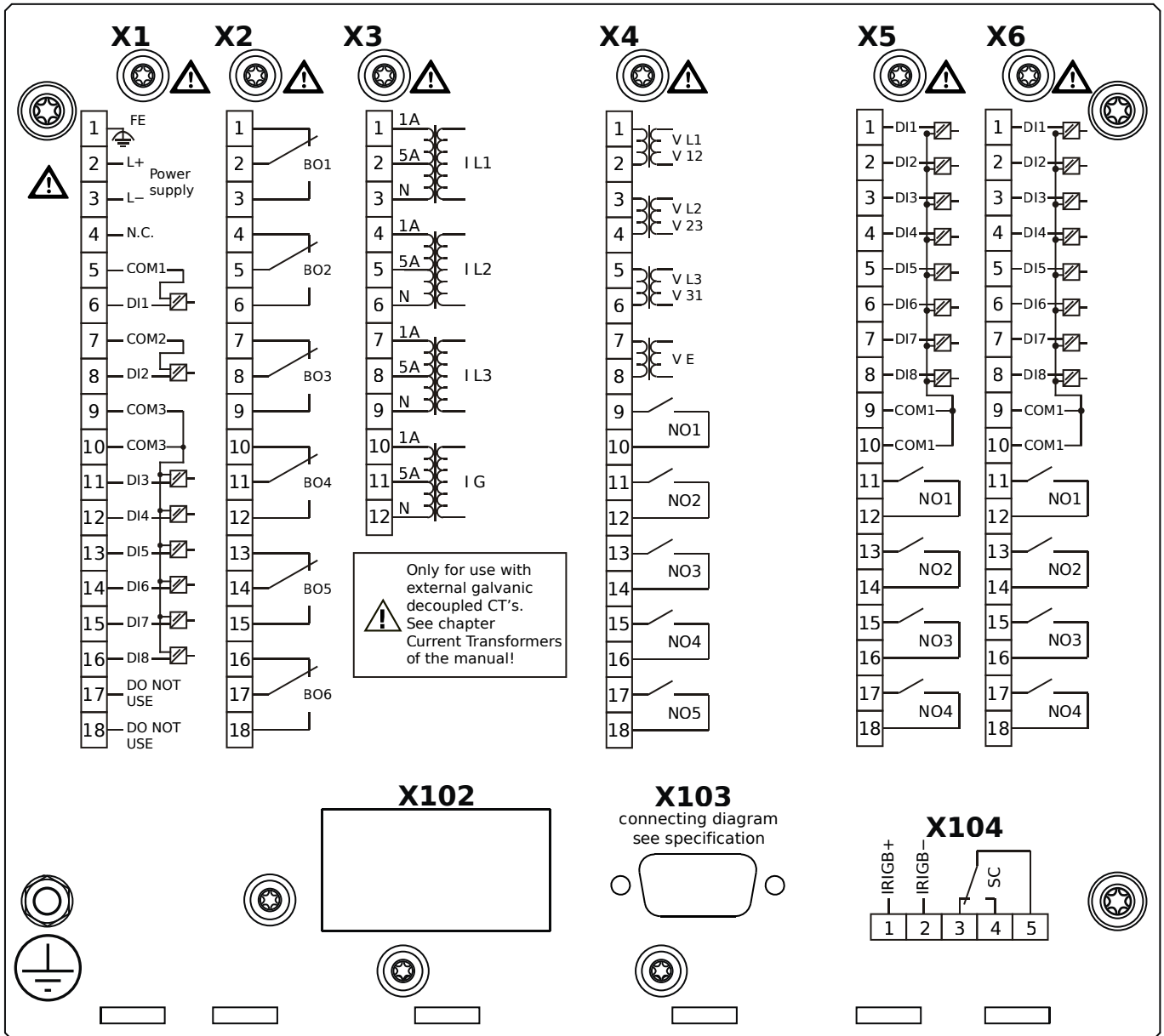

Housing B2, small display, door mounting

- X1** – DI8-X1: Wide-range power supply unit, incl. 2 non-grouped digital inputs and 6 grouped digital inputs
- X2** – OR6: Assembly Group with 6 Output Relays (Changeover / Form C)
- X3** – TI: Standard current measuring card
- X4** – TU-OR5: Voltage measuring (0 ... 300 VAC) assembly group with 5 additional Output Relays (NO / Form A)
- X5** – DI8-OR4: Assembly Group with 8 Digital Inputs and 4 Output Relays (NO / Form A)
- X6** – DI8-OR4: Assembly Group with 8 Digital Inputs and 4 Output Relays (NO / Form A)
- X103** – Modbus RTU / IEC 60870-5-103 / DNP3.0 RTU, RS485, D-SUB
- X104** – IRIG-B00X, incl. System Contact (Supervision Contact)

MRA4-2E0AGB

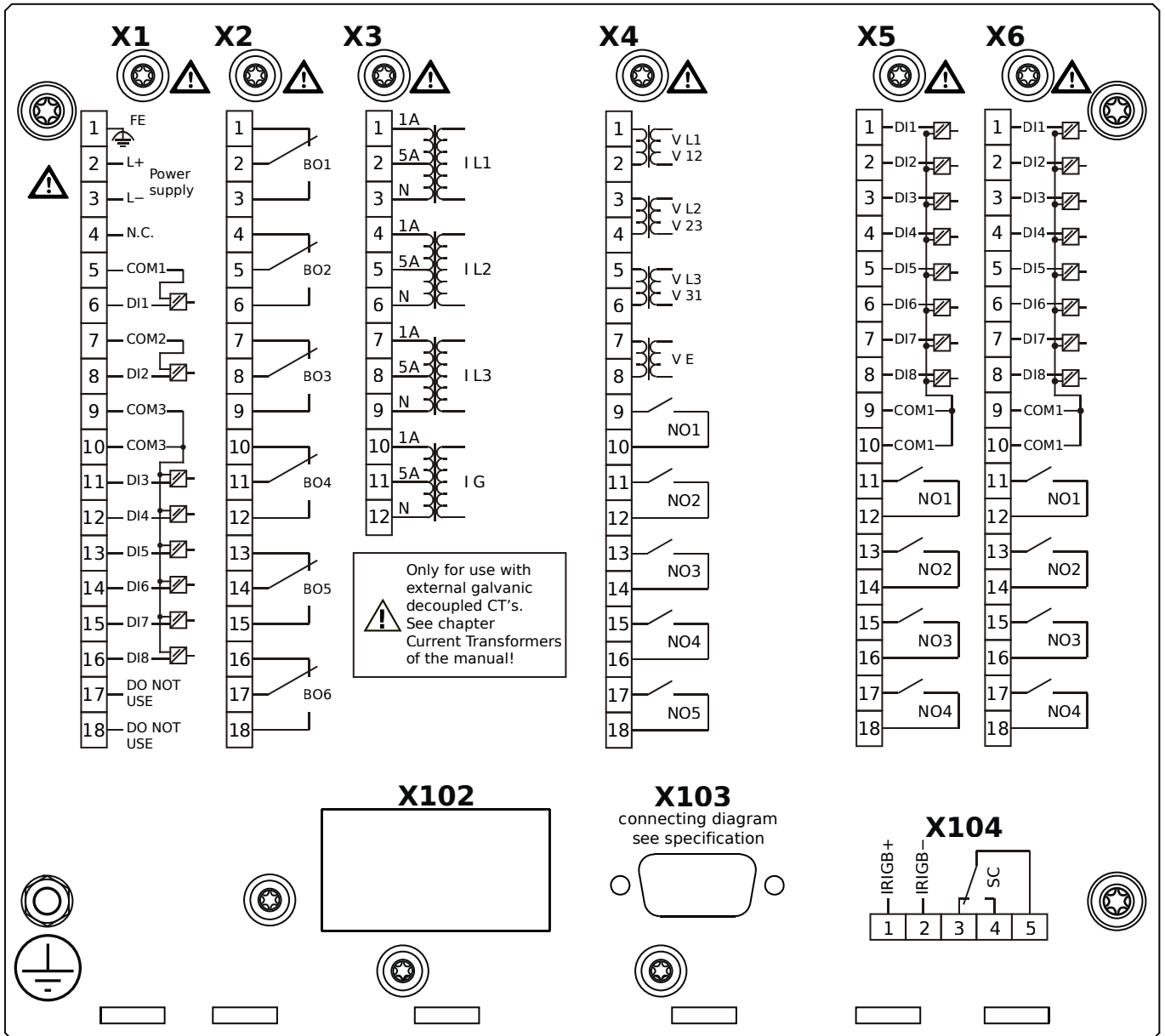

Housing B2, small display, door mounting

+ Conformal Coating (for installations in harsh environment)

- X1** – DI8-X1: Wide-range power supply unit, incl. 2 non-grouped digital inputs and 6 grouped digital inputs
- X2** – OR6: Assembly Group with 6 Output Relays (Changeover / Form C)
- X3** – TI: Standard current measuring card
- X4** – TU-OR5: Voltage measuring (0 ... 300 VAC) assembly group with 5 additional Output Relays (NO / Form A)
- X5** – DI8-OR4: Assembly Group with 8 Digital Inputs and 4 Output Relays (NO / Form A)
- X6** – DI8-OR4: Assembly Group with 8 Digital Inputs and 4 Output Relays (NO / Form A)
- X103** – Modbus RTU / IEC 60870-5-103 / DNP3.0 RTU, RS485, D-SUB
- X104** – IRIG-B00X, incl. System Contact (Supervision Contact)

MRA4-2E0AHA

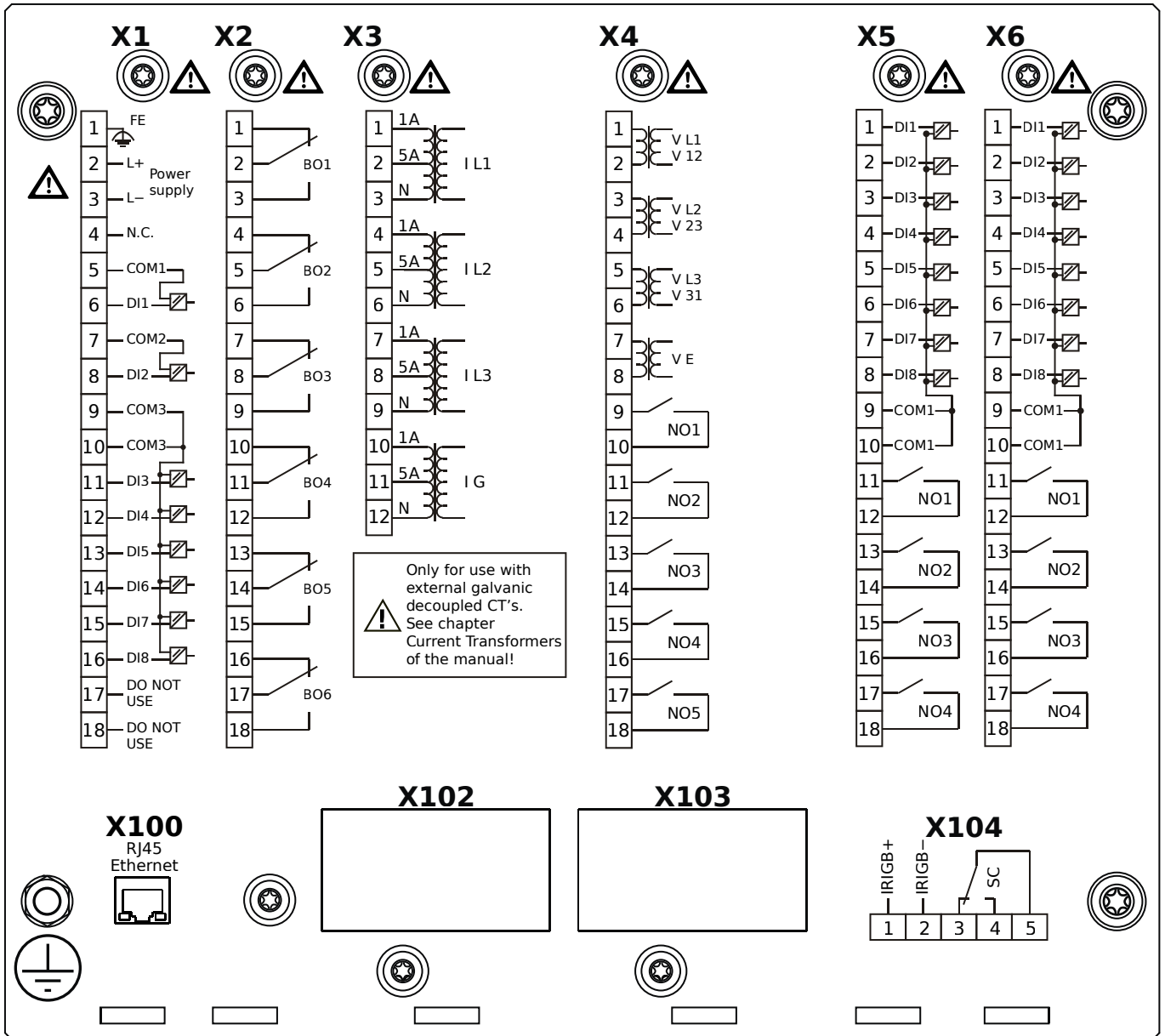

Housing B2, small display, door mounting

- X1** – DI8-X1: Wide-range power supply unit, incl. 2 non-grouped digital inputs and 6 grouped digital inputs
- X2** – OR6: Assembly Group with 6 Output Relays (Changeover / Form C)
- X3** – TI: Standard current measuring card
- X4** – TU-OR5: Voltage measuring (0 ... 300 VAC) assembly group with 5 additional Output Relays (NO / Form A)
- X5** – DI8-OR4: Assembly Group with 8 Digital Inputs and 4 Output Relays (NO / Form A)
- X6** – DI8-OR4: Assembly Group with 8 Digital Inputs and 4 Output Relays (NO / Form A)
- X100** – IEC 61850 / Modbus TCP / DNP3.0 TCP/UDP, Ethernet interface, 100 Mbit/s, RJ45 (BASE100-FX)
- X104** – IRIG-B00X, incl. System Contact (Supervision Contact)

MRA4-2E0AHB

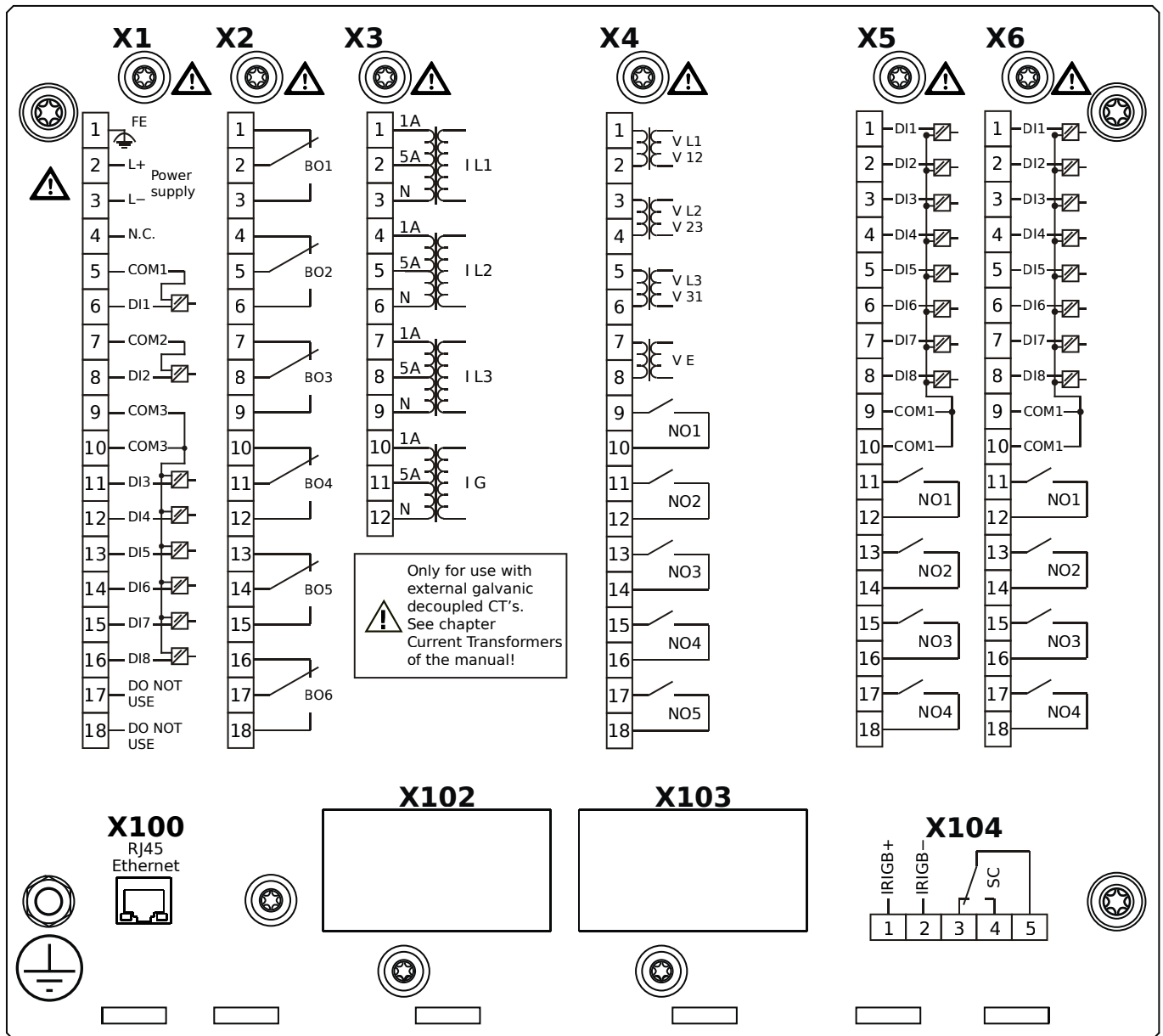

Housing B2, small display, door mounting

+ Conformal Coating (for installations in harsh environment)

- X1** – DI8-X1: Wide-range power supply unit, incl. 2 non-grouped digital inputs and 6 grouped digital inputs
- X2** – OR6: Assembly Group with 6 Output Relays (Changeover / Form C)
- X3** – TI: Standard current measuring card
- X4** – TU-OR5: Voltage measuring (0 ... 300 VAC) assembly group with 5 additional Output Relays (NO / Form A)
- X5** – DI8-OR4: Assembly Group with 8 Digital Inputs and 4 Output Relays (NO / Form A)
- X6** – DI8-OR4: Assembly Group with 8 Digital Inputs and 4 Output Relays (NO / Form A)
- X100** – IEC 61850 / Modbus TCP / DNP3.0 TCP/UDP, Ethernet interface, 100 Mbit/s, RJ45 (BASE100-FX)
- X104** – IRIG-B00X, incl. System Contact (Supervision Contact)

MRA4-2E0AIA

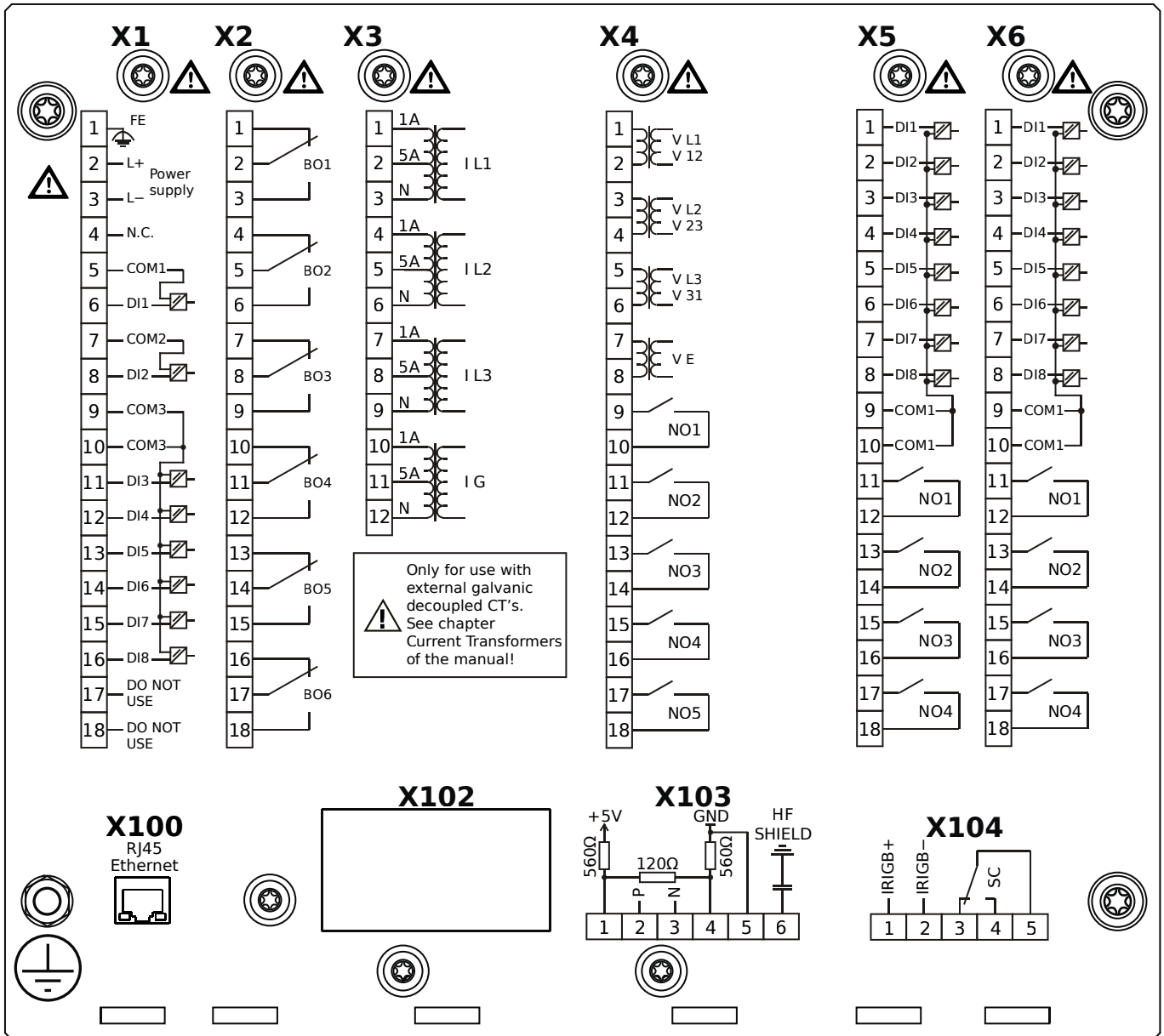

Housing B2, small display, door mounting

- X1** – DI8-X1: Wide-range power supply unit, incl. 2 non-grouped digital inputs and 6 grouped digital inputs
- X2** – OR6: Assembly Group with 6 Output Relays (Changeover / Form C)
- X3** – TI: Standard current measuring card
- X4** – TU-OR5: Voltage measuring (0 ... 300 VAC) assembly group with 5 additional Output Relays (NO / Form A)
- X5** – DI8-OR4: Assembly Group with 8 Digital Inputs and 4 Output Relays (NO / Form A)
- X6** – DI8-OR4: Assembly Group with 8 Digital Inputs and 4 Output Relays (NO / Form A)
- X100** – Modbus TCP / DNP3.0 TCP/UDP, Ethernet interface, 100 Mbit/s, RJ45 (BASE100-FX)
- X103** – IEC 60870-5-103 / Modbus RTU / DNP3.0 RTU, RS485, Terminals
- X104** – IRIG-B00X, incl. System Contact (Supervision Contact)

MRA4-2E0AIB

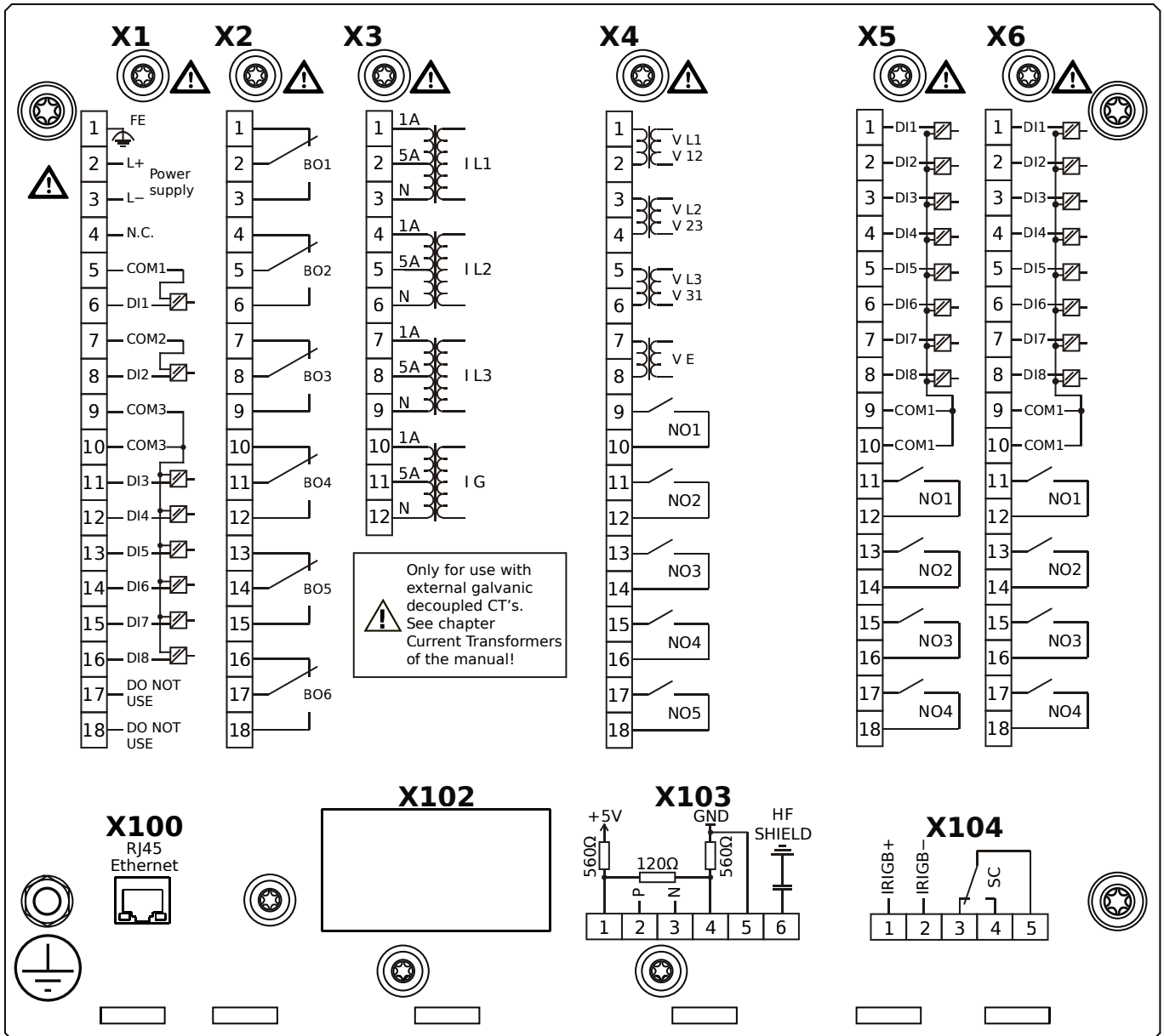

Housing B2, small display, door mounting

- + Conformal Coating (for installations in harsh environment)

- X1** – DI8-X1: Wide-range power supply unit, incl. 2 non-grouped digital inputs and 6 grouped digital inputs
- X2** – OR6: Assembly Group with 6 Output Relays (Changeover / Form C)
- X3** – TI: Standard current measuring card
- X4** – TU-OR5: Voltage measuring (0 ... 300 VAC) assembly group with 5 additional Output Relays (NO / Form A)
- X5** – DI8-OR4: Assembly Group with 8 Digital Inputs and 4 Output Relays (NO / Form A)
- X6** – DI8-OR4: Assembly Group with 8 Digital Inputs and 4 Output Relays (NO / Form A)
- X100** – Modbus TCP / DNP3.0 TCP/UDP, Ethernet interface, 100 Mbit/s, RJ45 (BASE100-FX)
- X103** – IEC 60870-5-103 / Modbus RTU / DNP3.0 RTU, RS485, Terminals
- X104** – IRIG-B00X, incl. System Contact (Supervision Contact)

MRA4-2E0AKA

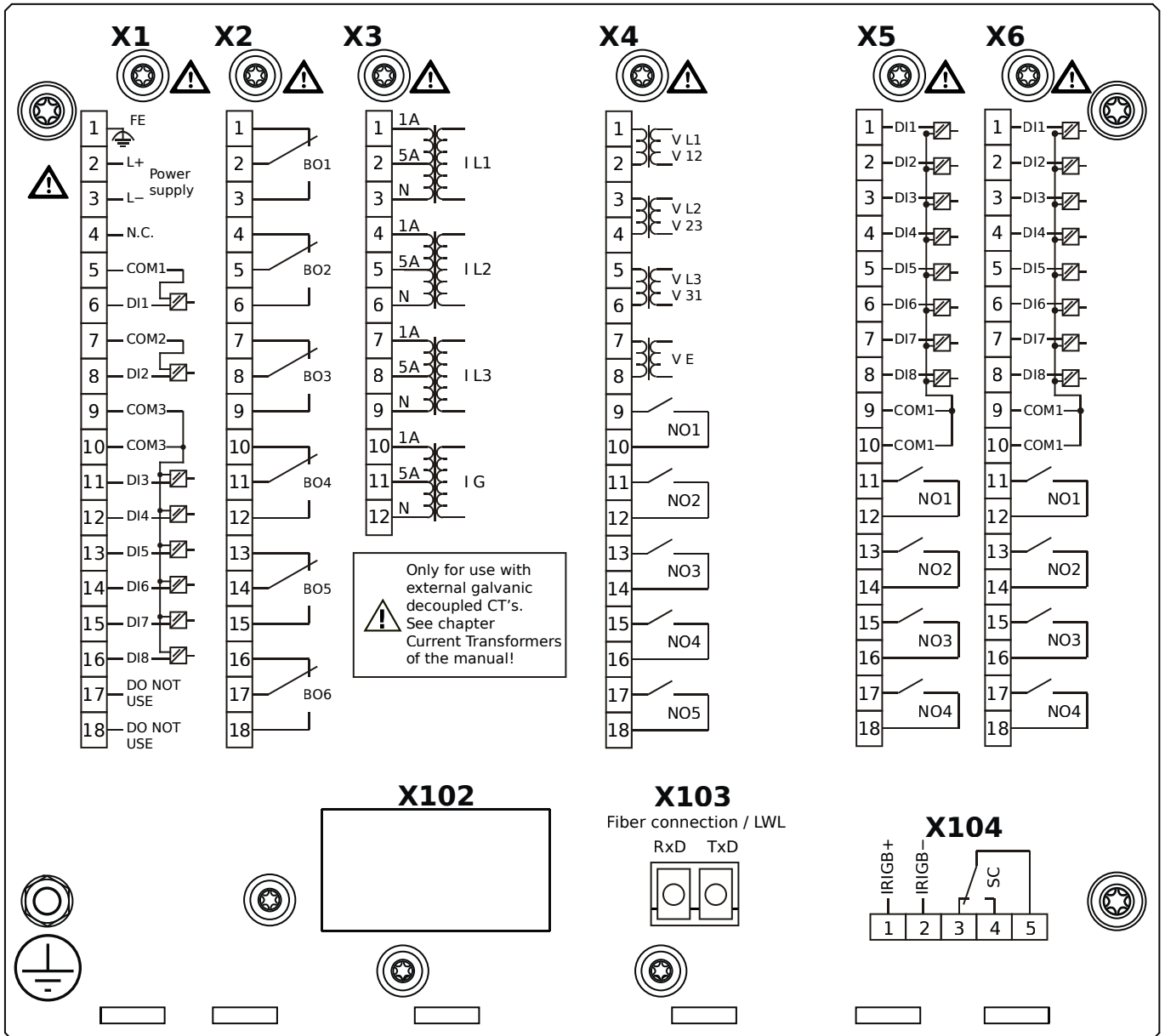

Housing B2, small display, door mounting

- X1** – DI8-X1: Wide-range power supply unit, incl. 2 non-grouped digital inputs and 6 grouped digital inputs
- X2** – OR6: Assembly Group with 6 Output Relays (Changeover / Form C)
- X3** – TI: Standard current measuring card
- X4** – TU-OR5: Voltage measuring (0 ... 300 VAC) assembly group with 5 additional Output Relays (NO / Form A)
- X5** – DI8-OR4: Assembly Group with 8 Digital Inputs and 4 Output Relays (NO / Form A)
- X6** – DI8-OR4: Assembly Group with 8 Digital Inputs and 4 Output Relays (NO / Form A)
- X103** – IEC 61850 / Modbus TCP / DNP3.0 TCP/UDP, Fiber optics interface, LC Connector
- X104** – IRIG-B00X, incl. System Contact (Supervision Contact)

MRA4-2E0AKB

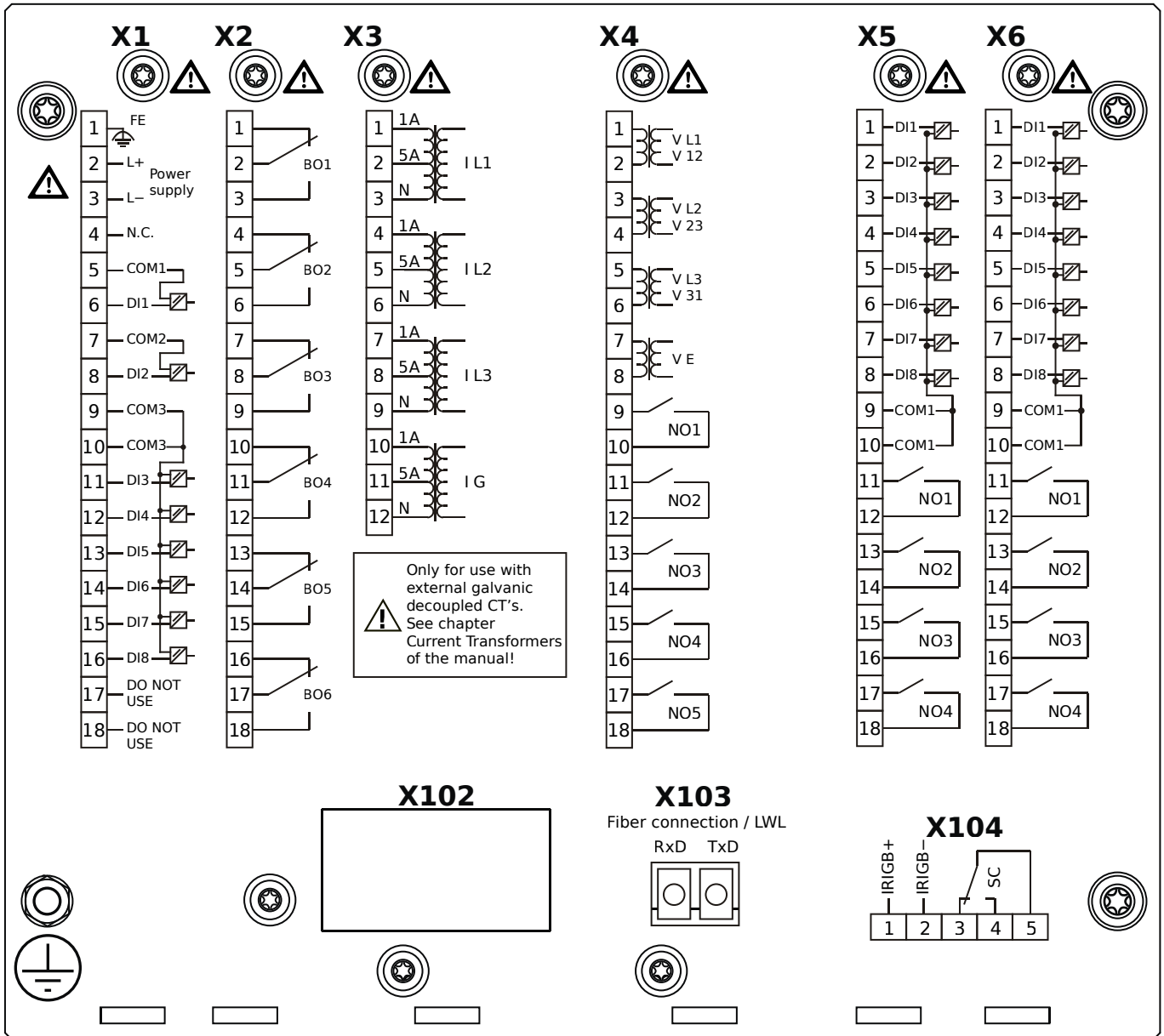

Housing B2, small display, door mounting

+ Conformal Coating (for installations in harsh environment)

- X1** – DI8-X1: Wide-range power supply unit, incl. 2 non-grouped digital inputs and 6 grouped digital inputs
- X2** – OR6: Assembly Group with 6 Output Relays (Changeover / Form C)
- X3** – TI: Standard current measuring card
- X4** – TU-OR5: Voltage measuring (0 ... 300 VAC) assembly group with 5 additional Output Relays (NO / Form A)
- X5** – DI8-OR4: Assembly Group with 8 Digital Inputs and 4 Output Relays (NO / Form A)
- X6** – DI8-OR4: Assembly Group with 8 Digital Inputs and 4 Output Relays (NO / Form A)
- X103** – IEC 61850 / Modbus TCP / DNP3.0 TCP/UDP, Fiber optics interface, LC Connector
- X104** – IRIG-B00X, incl. System Contact (Supervision Contact)

MRA4-2E0ALA

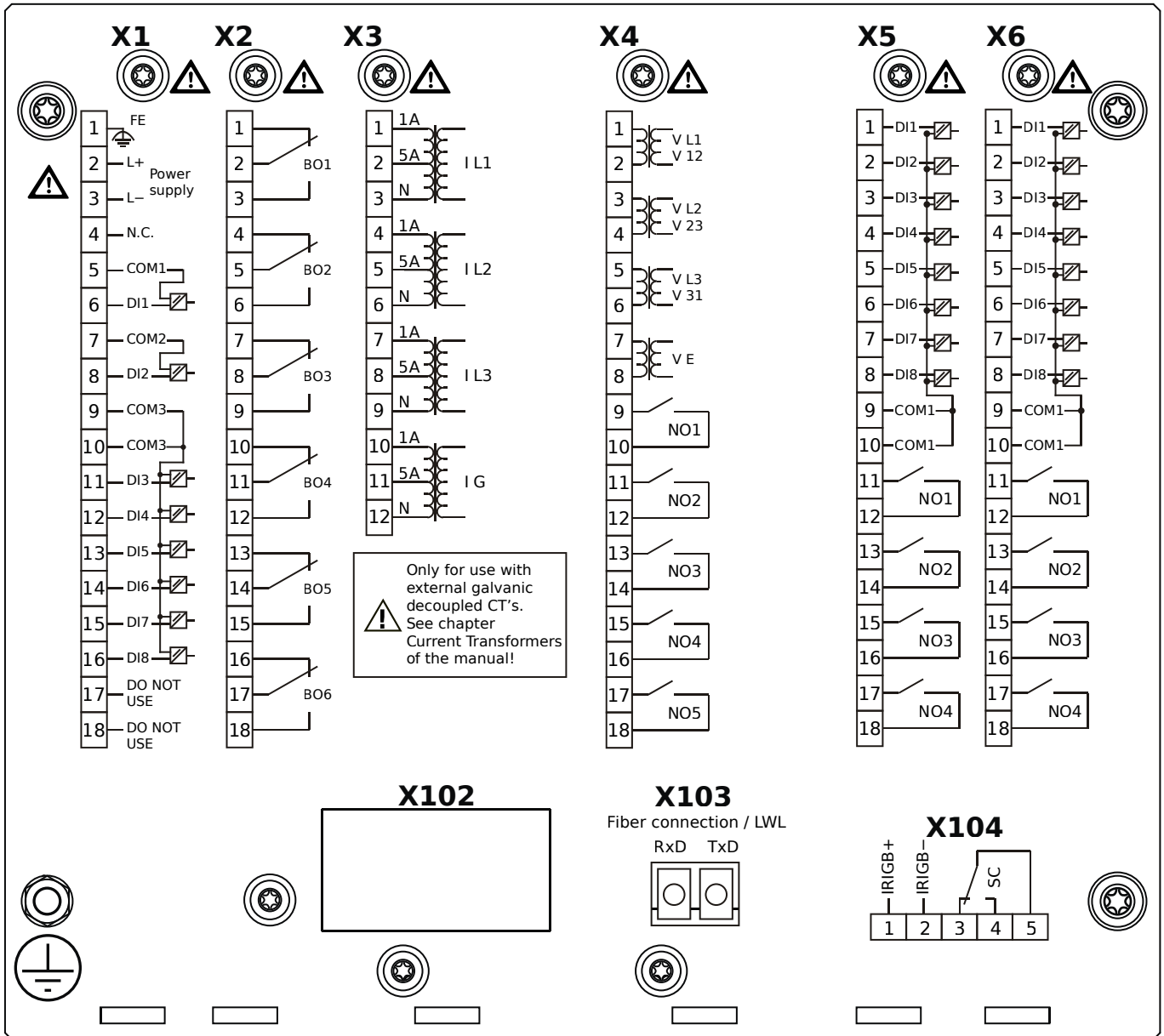

Housing B2, small display, door mounting

- X1** – DI8-X1: Wide-range power supply unit, incl. 2 non-grouped digital inputs and 6 grouped digital inputs
- X2** – OR6: Assembly Group with 6 Output Relays (Changeover / Form C)
- X3** – TI: Standard current measuring card
- X4** – TU-OR5: Voltage measuring (0 ... 300 VAC) assembly group with 5 additional Output Relays (NO / Form A)
- X5** – DI8-OR4: Assembly Group with 8 Digital Inputs and 4 Output Relays (NO / Form A)
- X6** – DI8-OR4: Assembly Group with 8 Digital Inputs and 4 Output Relays (NO / Form A)
- X103** – Modbus TCP / DNP3.0 TCP/UDP, Fiber optics interface, LC Connector
- X104** – IRIG-B00X, incl. System Contact (Supervision Contact)

MRA4-2E0ALB

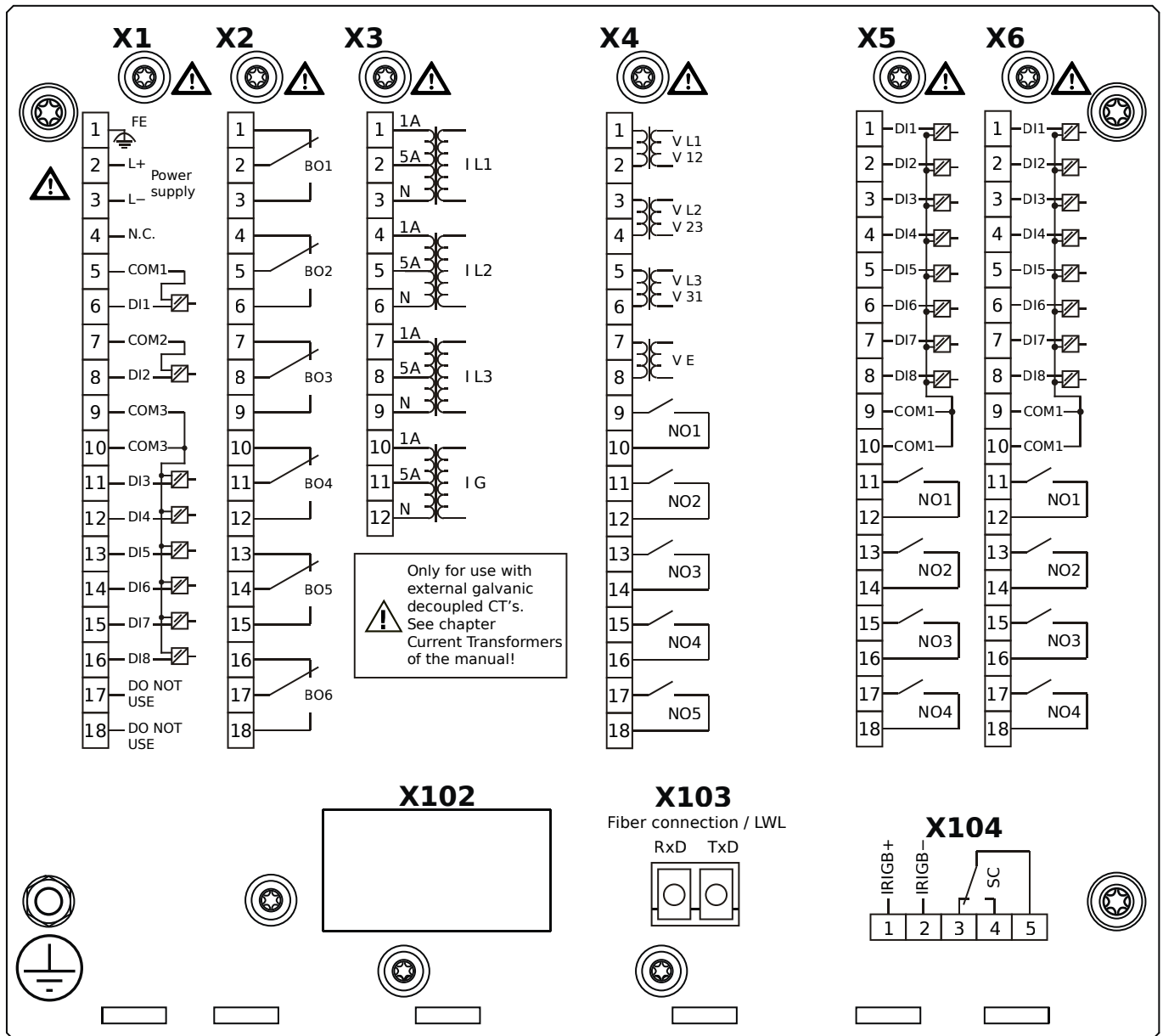

Housing B2, small display, door mounting

- + Conformal Coating (for installations in harsh environment)

- X1** – DI8-X1: Wide-range power supply unit, incl. 2 non-grouped digital inputs and 6 grouped digital inputs
- X2** – OR6: Assembly Group with 6 Output Relays (Changeover / Form C)
- X3** – TI: Standard current measuring card
- X4** – TU-OR5: Voltage measuring (0 ... 300 VAC) assembly group with 5 additional Output Relays (NO / Form A)
- X5** – DI8-OR4: Assembly Group with 8 Digital Inputs and 4 Output Relays (NO / Form A)
- X6** – DI8-OR4: Assembly Group with 8 Digital Inputs and 4 Output Relays (NO / Form A)
- X103** – Modbus TCP / DNP3.0 TCP/UDP, Fiber optics interface, LC Connector
- X104** – IRIG-B00X, incl. System Contact (Supervision Contact)

MRA4-2E0ATA

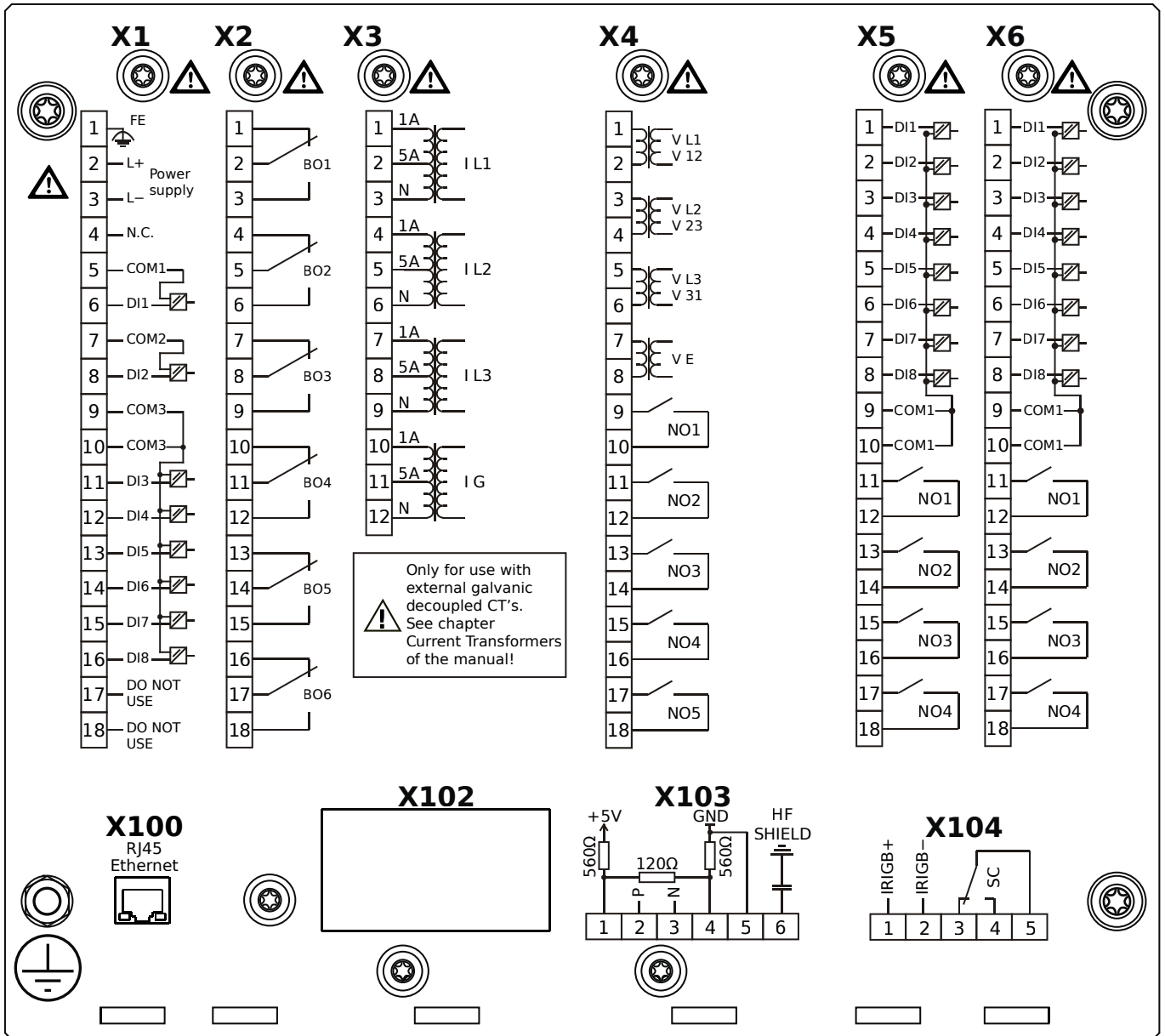

Housing B2, small display, door mounting

- X1** – DI8-X1: Wide-range power supply unit, incl. 2 non-grouped digital inputs and 6 grouped digital inputs
- X2** – OR6: Assembly Group with 6 Output Relays (Changeover / Form C)
- X3** – TI: Standard current measuring card
- X4** – TU-OR5: Voltage measuring (0 ... 300 VAC) assembly group with 5 additional Output Relays (NO / Form A)
- X5** – DI8-OR4: Assembly Group with 8 Digital Inputs and 4 Output Relays (NO / Form A)
- X6** – DI8-OR4: Assembly Group with 8 Digital Inputs and 4 Output Relays (NO / Form A)
- X100** – IEC 61850 / Modbus TCP / DNP3.0 TCP/UDP, Ethernet interface, 100 Mbit/s, RJ45 (BASE100-FX)
- X103** – IEC 60870-5-103 / Modbus RTU / DNP3.0 RTU, RS485, Terminals
- X104** – I R I G B-00X, incl. System Contact (Supervision Contact)

MRA4-2E0ATB

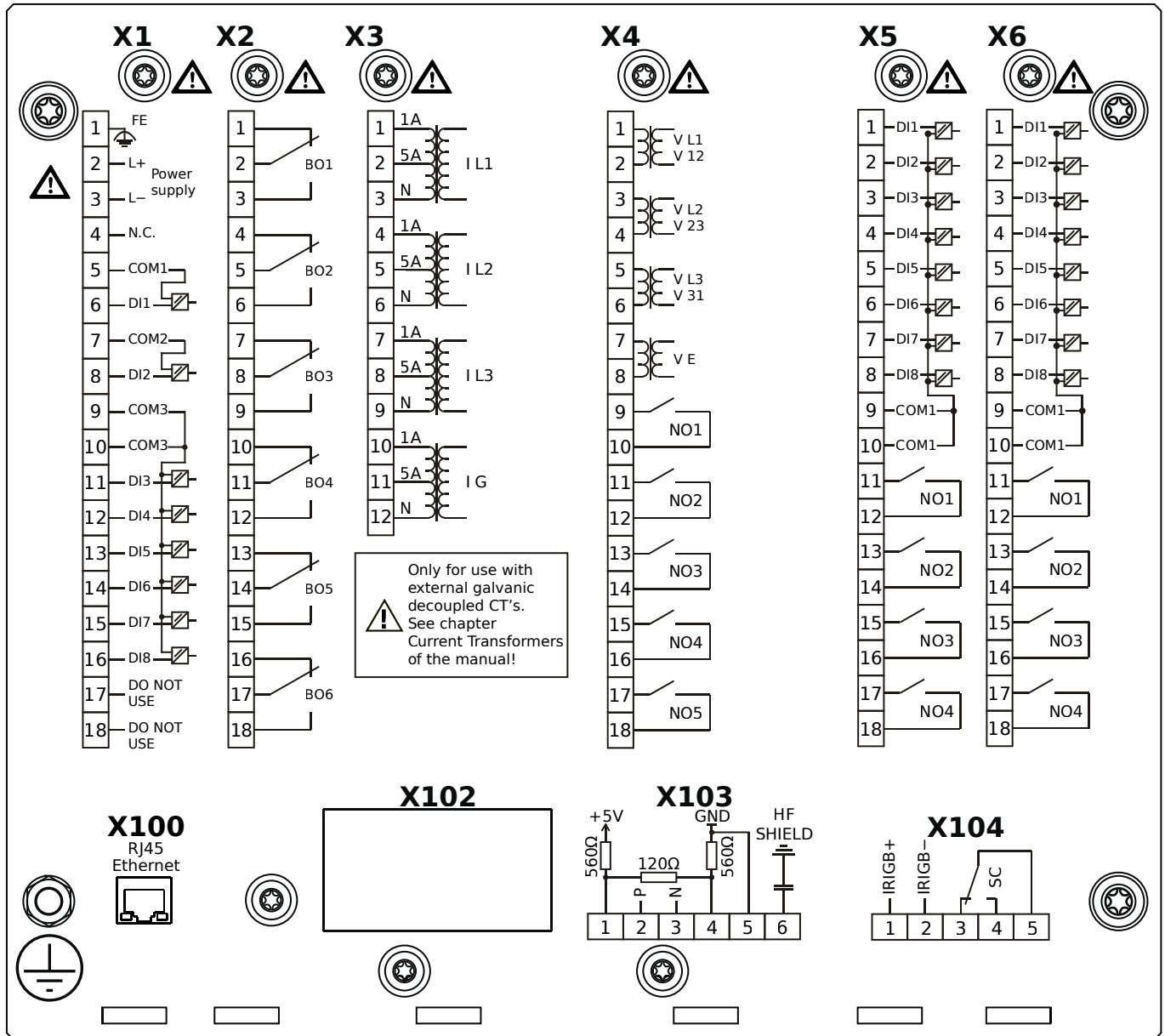

Housing B2, small display, door mounting

- + Conformal Coating (for installations in harsh environment)

- X1** – DI8-X1: Wide-range power supply unit, incl. 2 non-grouped digital inputs and 6 grouped digital inputs
- X2** – OR6: Assembly Group with 6 Output Relays (Changeover / Form C)
- X3** – TI: Standard current measuring card
- X4** – TU-OR5: Voltage measuring (0 ... 300 VAC) assembly group with 5 additional Output Relays (NO / Form A)
- X5** – DI8-OR4: Assembly Group with 8 Digital Inputs and 4 Output Relays (NO / Form A)
- X6** – DI8-OR4: Assembly Group with 8 Digital Inputs and 4 Output Relays (NO / Form A)
- X100** – IEC 61850 / Modbus TCP / DNP3.0 TCP/UDP, Ethernet interface, 100 Mbit/s, RJ45 (BASE100-FX)
- X103** – IEC 60870-5-103 / Modbus RTU / DNP3.0 RTU, RS485, Terminals
- X104** – I/RGB-B00X, incl. System Contact (Supervision Contact)

MRA4-2E0BAA

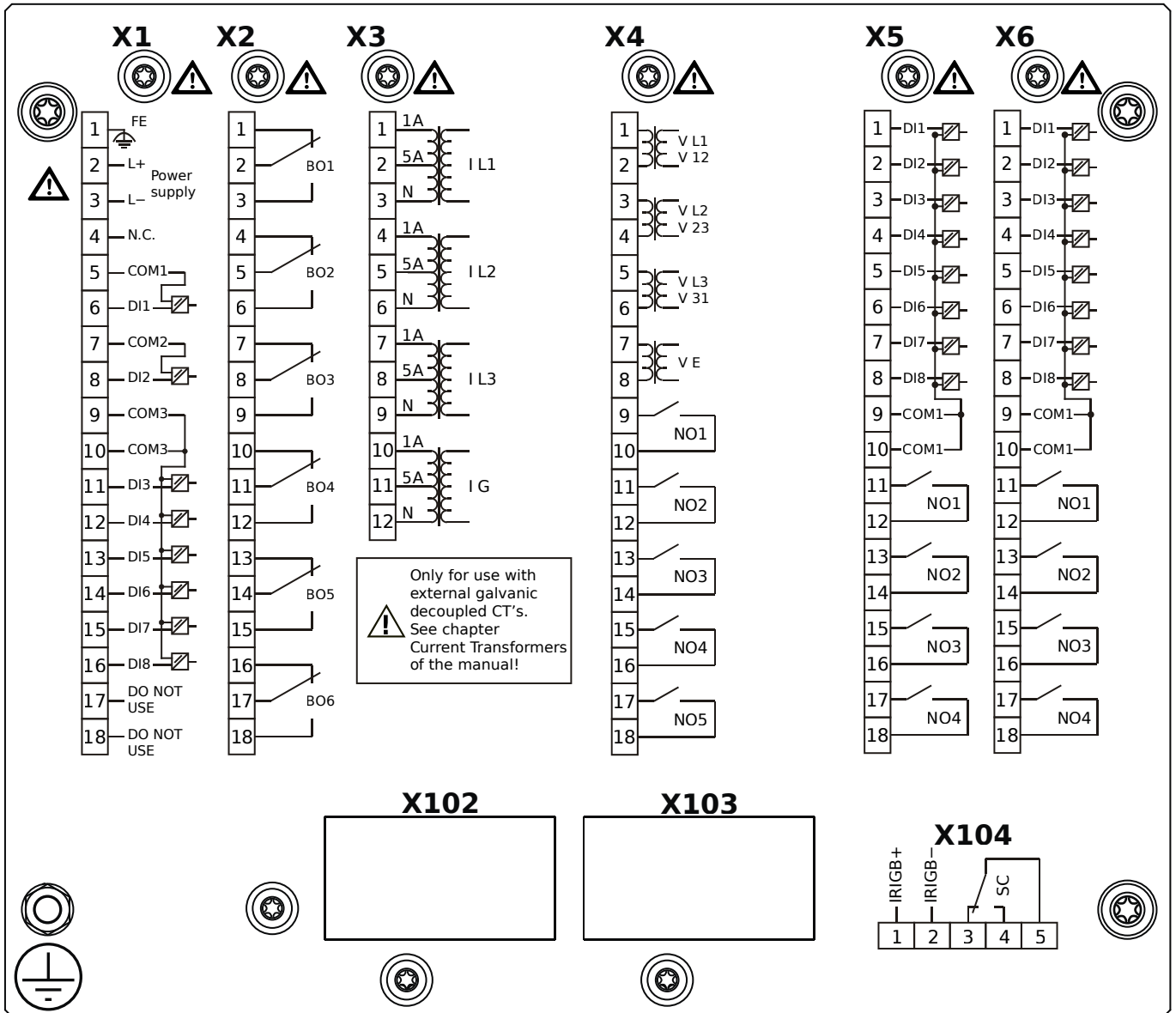

Housing B2, small display, 19" rack mounting

- X1** – DI8-X1: Wide-range power supply unit, incl. 2 non-grouped digital inputs and 6 grouped digital inputs
- X2** – OR6: Assembly Group with 6 Output Relays (Changeover / Form C)
- X3** – TI: Standard current measuring card
- X4** – TU-OR5: Voltage measuring (0 ... 300 VAC) assembly group with 5 additional Output Relays (NO / Form A)
- X5** – DI8-OR4: Assembly Group with 8 Digital Inputs and 4 Output Relays (NO / Form A)
- X6** – DI8-OR4: Assembly Group with 8 Digital Inputs and 4 Output Relays (NO / Form A)
- X104** – IRIG-B00X, incl. System Contact (Supervision Contact)

MRA4-2E0BAB

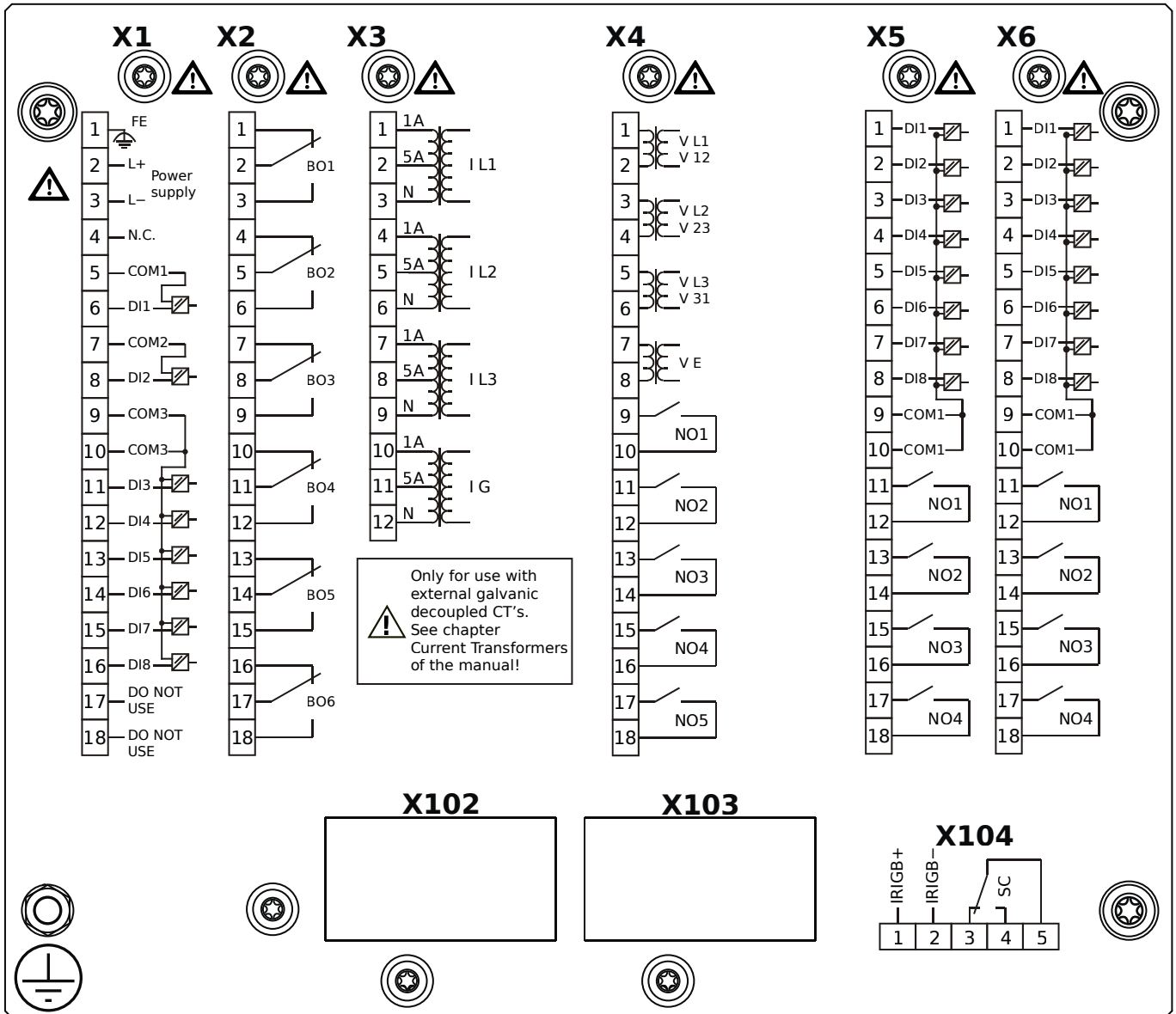

Housing B2, small display, 19" rack mounting

+ Conformal Coating (for installations in harsh environment)

- X1** – DI8-X1: Wide-range power supply unit, incl. 2 non-grouped digital inputs and 6 grouped digital inputs
- X2** – OR6: Assembly Group with 6 Output Relays (Changeover / Form C)
- X3** – TI: Standard current measuring card
- X4** – TU-OR5: Voltage measuring (0 ... 300 VAC) assembly group with 5 additional Output Relays (NO / Form A)
- X5** – DI8-OR4: Assembly Group with 8 Digital Inputs and 4 Output Relays (NO / Form A)
- X6** – DI8-OR4: Assembly Group with 8 Digital Inputs and 4 Output Relays (NO / Form A)
- X104** – IRIG-B00X, incl. System Contact (Supervision Contact)

MRA4-2E0BBA

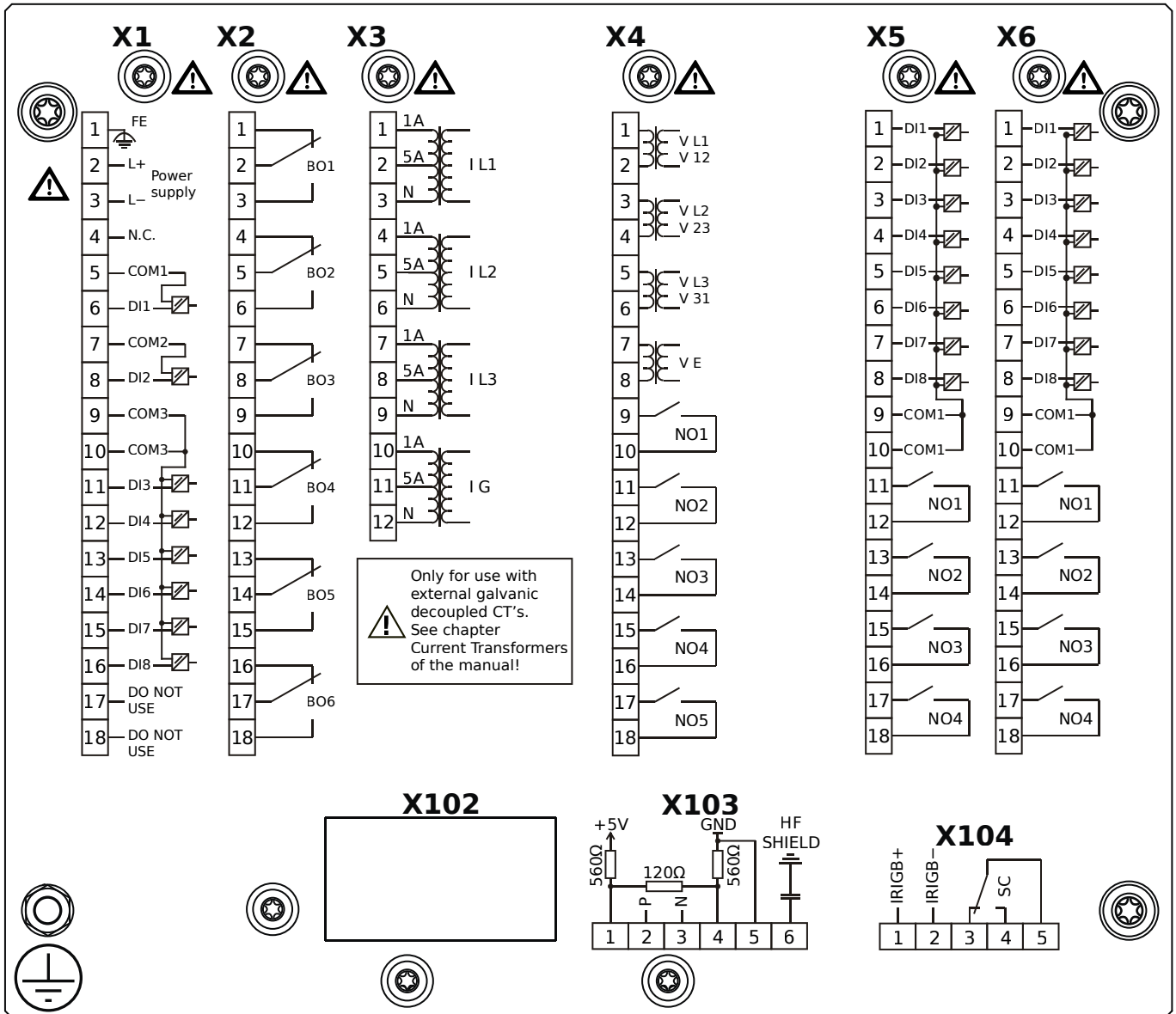

Housing B2, small display, 19" rack mounting

- X1** – DI8-X1: Wide-range power supply unit, incl. 2 non-grouped digital inputs and 6 grouped digital inputs
- X2** – OR6: Assembly Group with 6 Output Relays (Changeover / Form C)
- X3** – TI: Standard current measuring card
- X4** – TU-OR5: Voltage measuring (0 ... 300 VAC) assembly group with 5 additional Output Relays (NO / Form A)
- X5** – DI8-OR4: Assembly Group with 8 Digital Inputs and 4 Output Relays (NO / Form A)
- X6** – DI8-OR4: Assembly Group with 8 Digital Inputs and 4 Output Relays (NO / Form A)
- X103** – Modbus RTU / IEC 60870-5-103 / DNP3.0 RTU, RS485, Terminals
- X104** – IRIG-B00X, incl. System Contact (Supervision Contact)

MRA4-2E0BBB

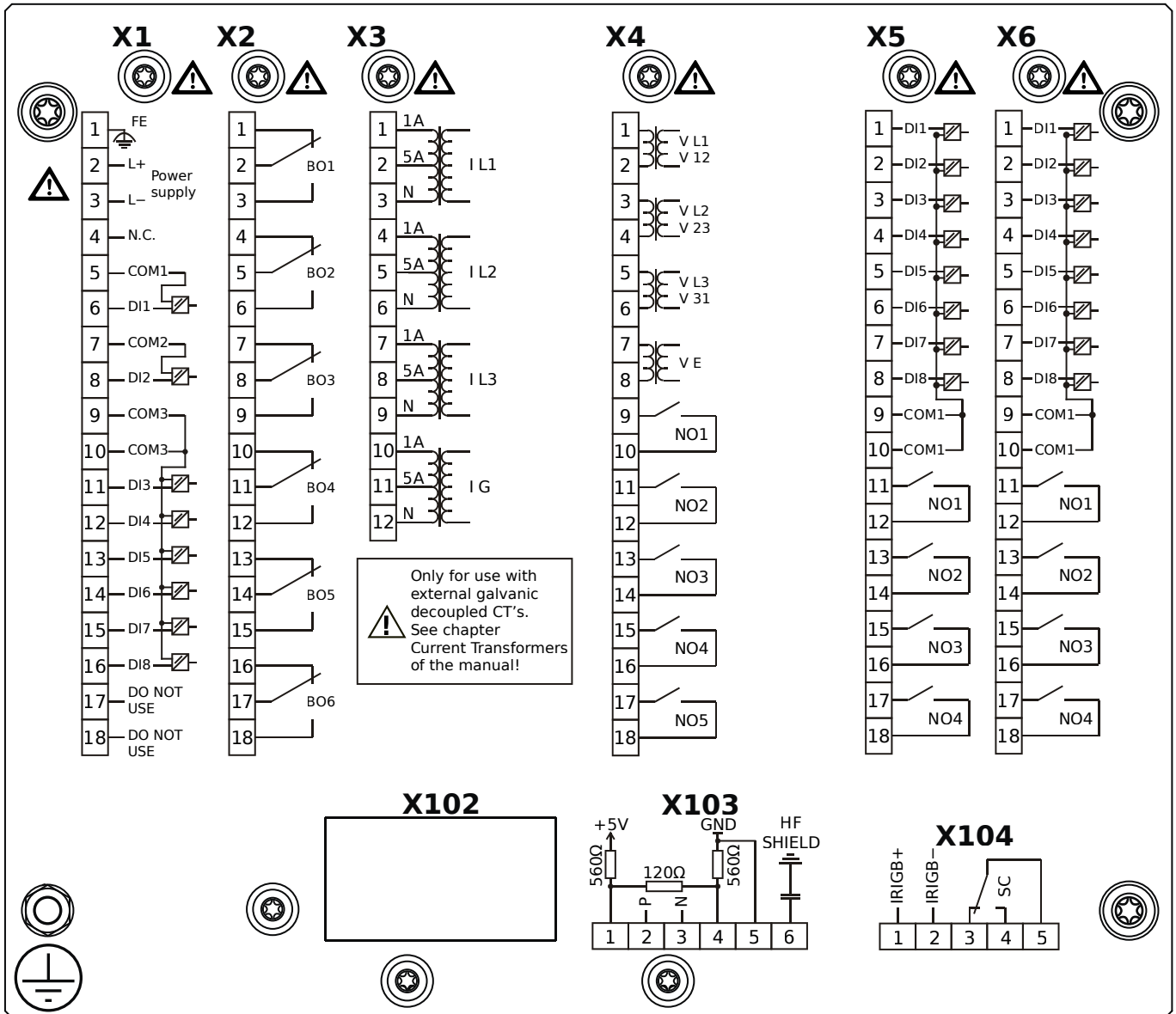

Housing B2, small display, 19" rack mounting

+ Conformal Coating (for installations in harsh environment)

- X1** – DI8-X1: Wide-range power supply unit, incl. 2 non-grouped digital inputs and 6 grouped digital inputs
- X2** – OR6: Assembly Group with 6 Output Relays (Changeover / Form C)
- X3** – TI: Standard current measuring card
- X4** – TU-OR5: Voltage measuring (0 ... 300 VAC) assembly group with 5 additional Output Relays (NO / Form A)
- X5** – DI8-OR4: Assembly Group with 8 Digital Inputs and 4 Output Relays (NO / Form A)
- X6** – DI8-OR4: Assembly Group with 8 Digital Inputs and 4 Output Relays (NO / Form A)
- X103** – Modbus RTU / IEC 60870-5-103 / DNP3.0 RTU, RS485, Terminals
- X104** – IRIG-B00X, incl. System Contact (Supervision Contact)

MRA4-2E0BCA

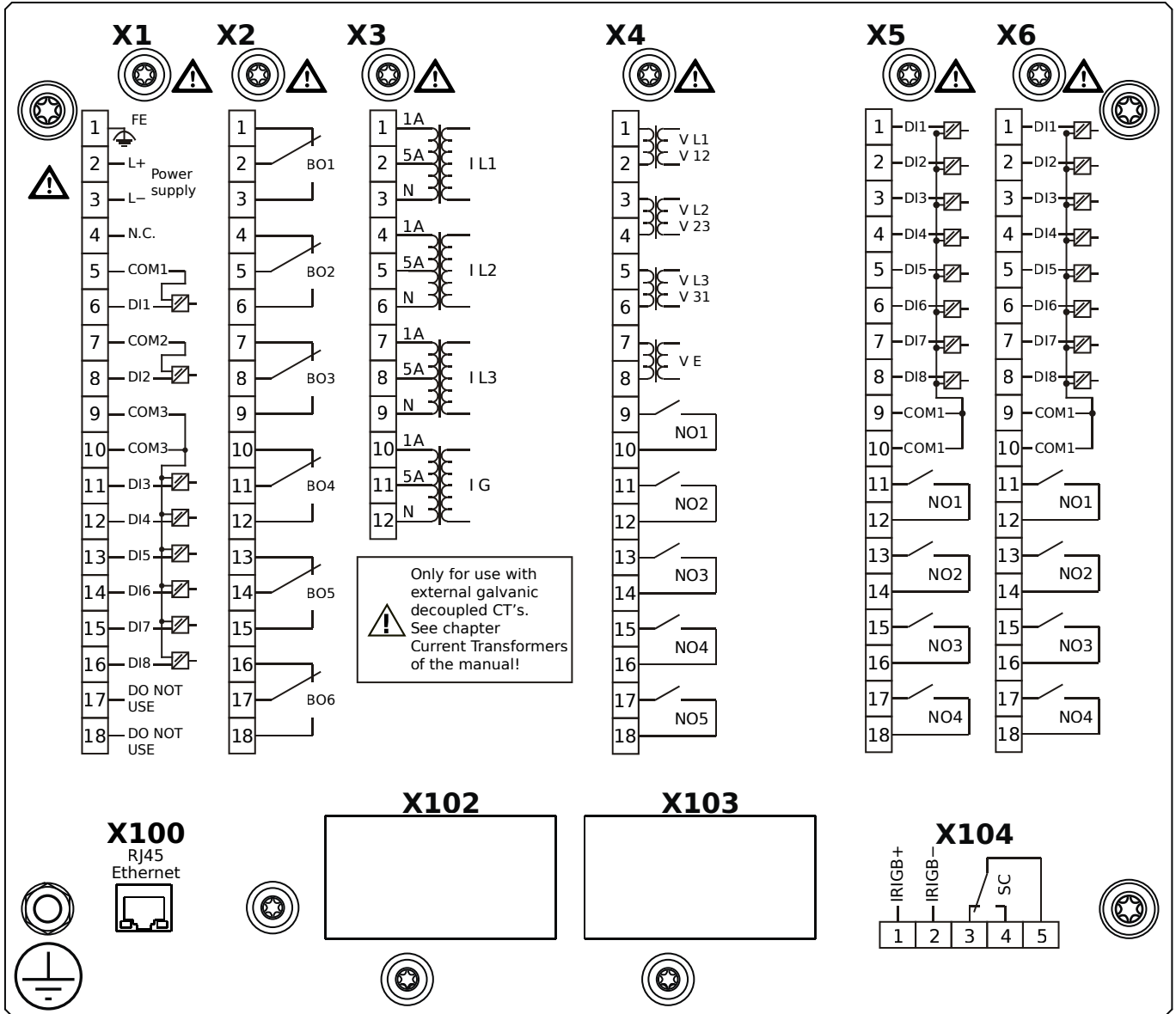

Housing B2, small display, 19" rack mounting

- X1** – DI8-X1: Wide-range power supply unit, incl. 2 non-grouped digital inputs and 6 grouped digital inputs
- X2** – OR6: Assembly Group with 6 Output Relays (Changeover / Form C)
- X3** – TI: Standard current measuring card
- X4** – TU-OR5: Voltage measuring (0 ... 300 VAC) assembly group with 5 additional Output Relays (NO / Form A)
- X5** – DI8-OR4: Assembly Group with 8 Digital Inputs and 4 Output Relays (NO / Form A)
- X6** – DI8-OR4: Assembly Group with 8 Digital Inputs and 4 Output Relays (NO / Form A)
- X100** – Modbus TCP / DNP3.0 TCP/UDP, Ethernet interface, 100 Mbit/s, RJ45 (BASE100-FX)
- X104** – IRIG-B00X, incl. System Contact (Supervision Contact)

MRA4-2E0BCB

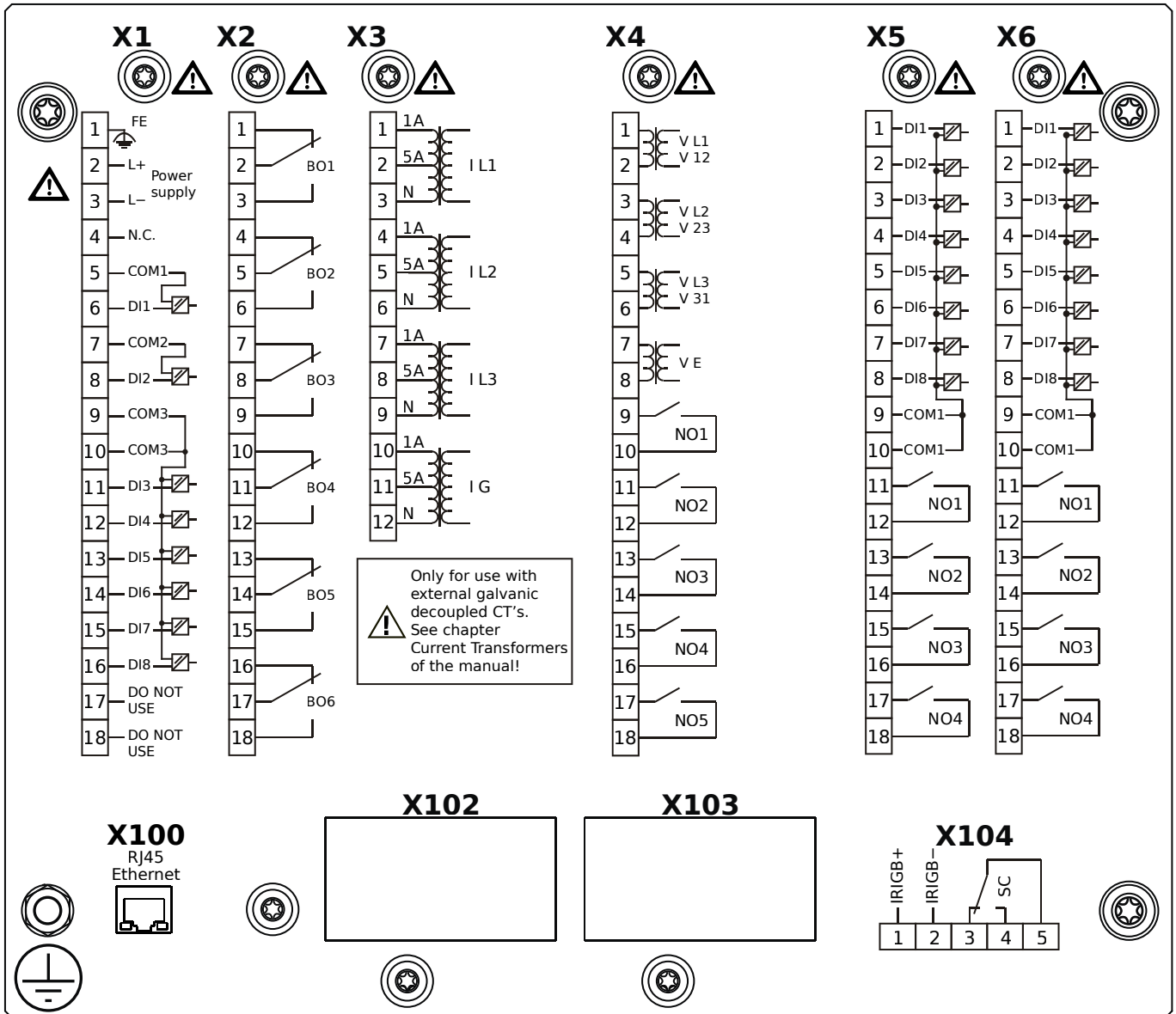

Housing B2, small display, 19" rack mounting

+ Conformal Coating (for installations in harsh environment)

- X1** – DI8-X1: Wide-range power supply unit, incl. 2 non-grouped digital inputs and 6 grouped digital inputs
- X2** – OR6: Assembly Group with 6 Output Relays (Changeover / Form C)
- X3** – TI: Standard current measuring card
- X4** – TU-OR5: Voltage measuring (0 ... 300 VAC) assembly group with 5 additional Output Relays (NO / Form A)
- X5** – DI8-OR4: Assembly Group with 8 Digital Inputs and 4 Output Relays (NO / Form A)
- X6** – DI8-OR4: Assembly Group with 8 Digital Inputs and 4 Output Relays (NO / Form A)
- X100** – Modbus TCP / DNP3.0 TCP/UDP, Ethernet interface, 100 Mbit/s, RJ45 (BASE100-FX)
- X104** – IRIG-B00X, incl. System Contact (Supervision Contact)

MRA4-2E0BDA

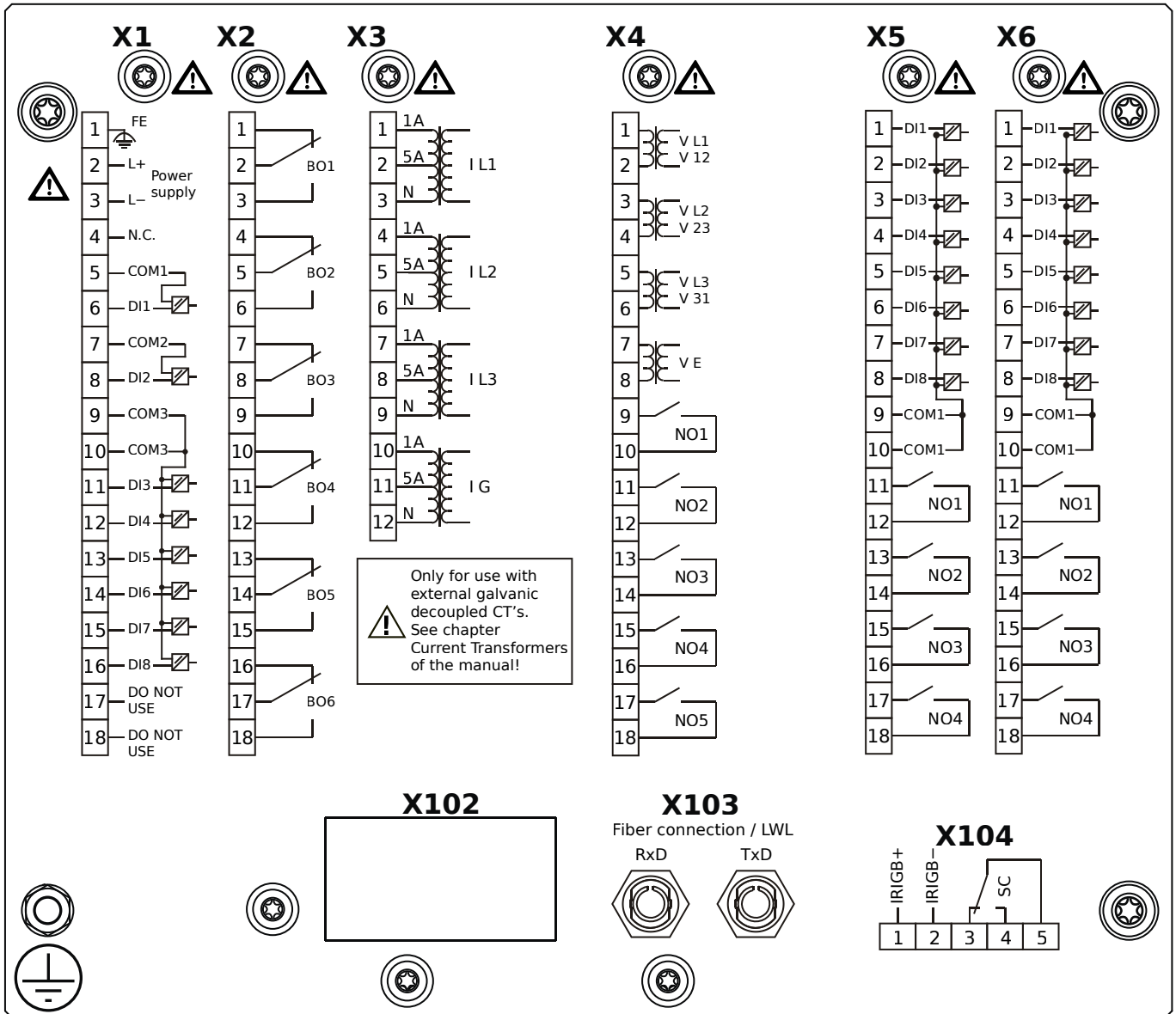

Housing B2, small display, 19" rack mounting

- X1** – DI8-X1: Wide-range power supply unit, incl. 2 non-grouped digital inputs and 6 grouped digital inputs
- X2** – OR6: Assembly Group with 6 Output Relays (Changeover / Form C)
- X3** – TI: Standard current measuring card
- X4** – TU-OR5: Voltage measuring (0 ... 300 VAC) assembly group with 5 additional Output Relays (NO / Form A)
- X5** – DI8-OR4: Assembly Group with 8 Digital Inputs and 4 Output Relays (NO / Form A)
- X6** – DI8-OR4: Assembly Group with 8 Digital Inputs and 4 Output Relays (NO / Form A)
- X103** – Profibus-DP, Fiber optics interface, ST Connector
- X104** – IRIG-B00X, incl. System Contact (Supervision Contact)

MRA4-2E0BDB

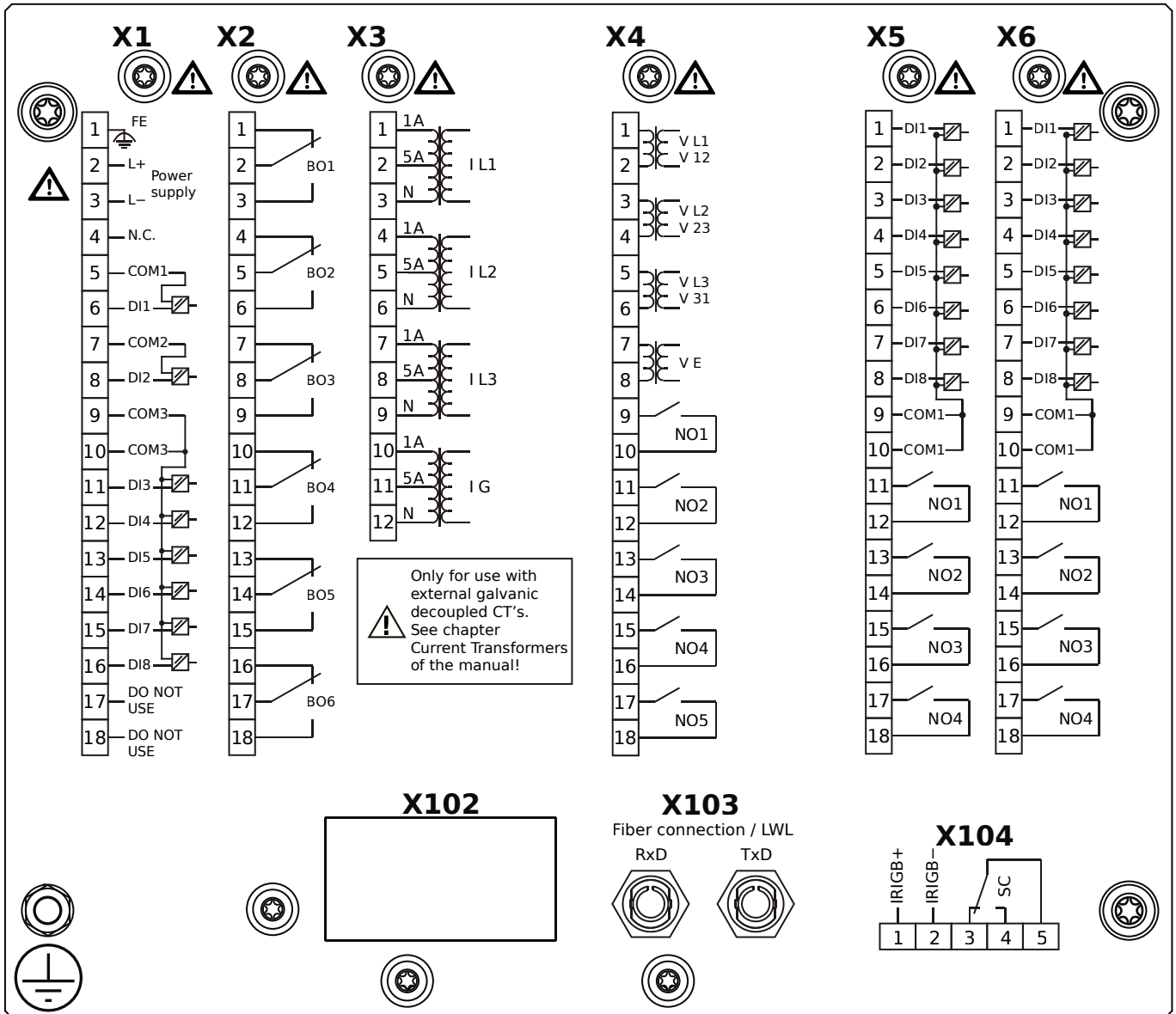

Housing B2, small display, 19" rack mounting

+ Conformal Coating (for installations in harsh environment)

- X1** – DI8-X1: Wide-range power supply unit, incl. 2 non-grouped digital inputs and 6 grouped digital inputs
- X2** – OR6: Assembly Group with 6 Output Relays (Changeover / Form C)
- X3** – TI: Standard current measuring card
- X4** – TU-OR5: Voltage measuring (0 ... 300 VAC) assembly group with 5 additional Output Relays (NO / Form A)
- X5** – DI8-OR4: Assembly Group with 8 Digital Inputs and 4 Output Relays (NO / Form A)
- X6** – DI8-OR4: Assembly Group with 8 Digital Inputs and 4 Output Relays (NO / Form A)
- X103** – Profibus-DP, Fiber optics interface, ST Connector
- X104** – IRIG-B00X, incl. System Contact (Supervision Contact)

MRA4-2E0BEA

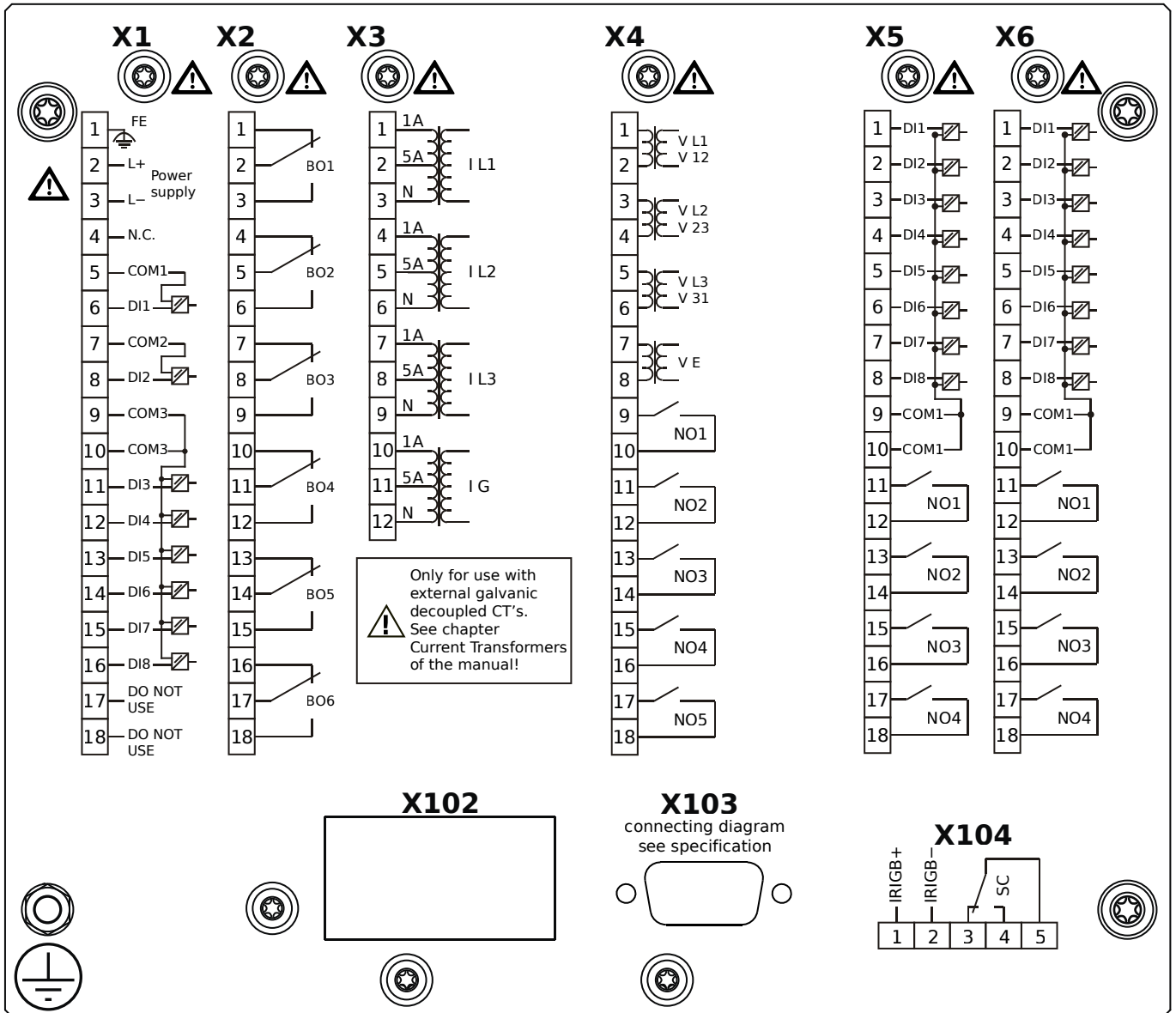

Housing B2, small display, 19" rack mounting

- X1** – DI8-X1: Wide-range power supply unit, incl. 2 non-grouped digital inputs and 6 grouped digital inputs
- X2** – OR6: Assembly Group with 6 Output Relays (Changeover / Form C)
- X3** – TI: Standard current measuring card
- X4** – TU-OR5: Voltage measuring (0 ... 300 VAC) assembly group with 5 additional Output Relays (NO / Form A)
- X5** – DI8-OR4: Assembly Group with 8 Digital Inputs and 4 Output Relays (NO / Form A)
- X6** – DI8-OR4: Assembly Group with 8 Digital Inputs and 4 Output Relays (NO / Form A)
- X103** – Profibus-DP, RS485, D-SUB
- X104** – IRIG-B00X, incl. System Contact (Supervision Contact)

MRA4-2E0BEB

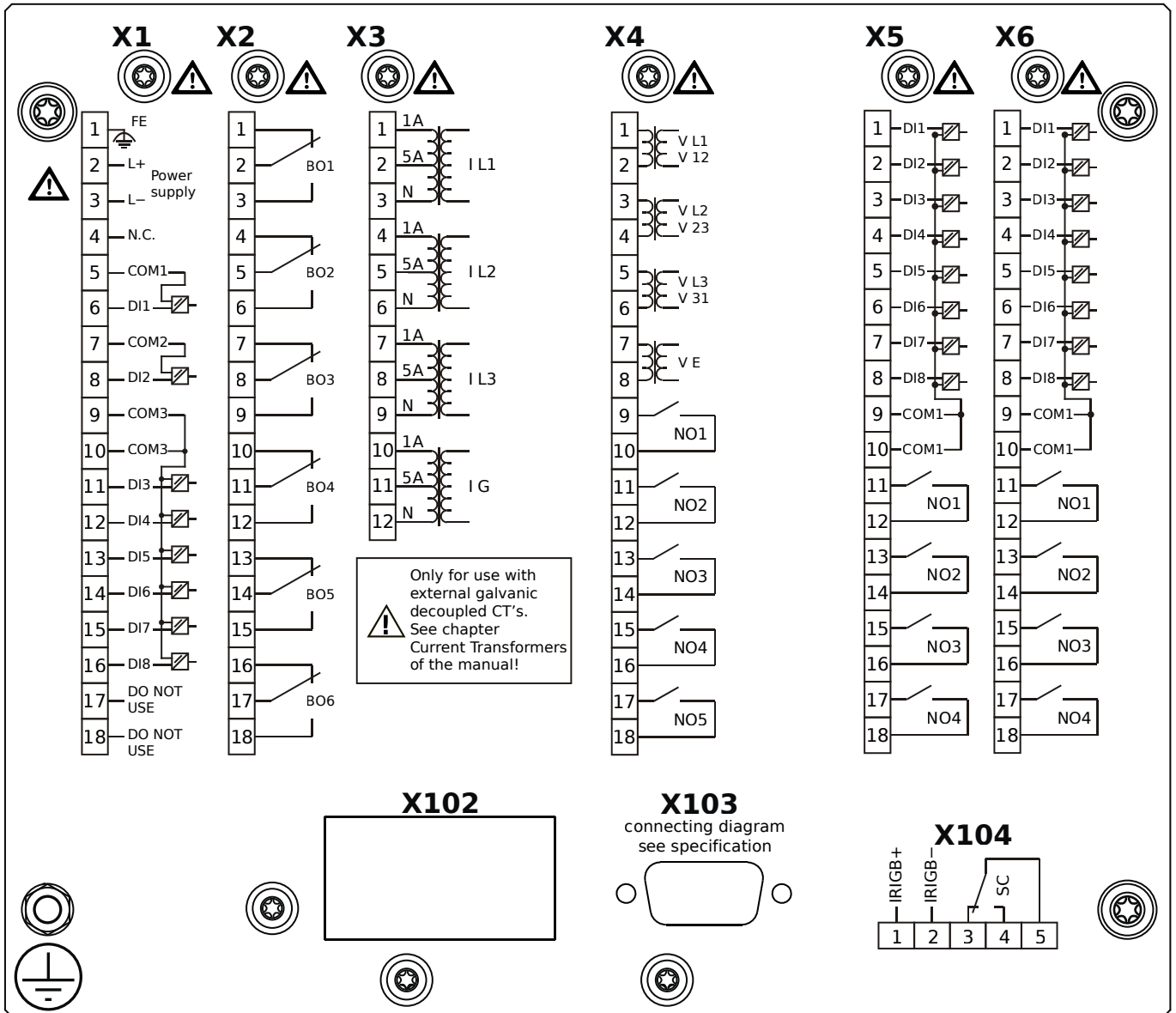

Housing B2, small display, 19" rack mounting

+ Conformal Coating (for installations in harsh environment)

- X1** – DI8-X1: Wide-range power supply unit, incl. 2 non-grouped digital inputs and 6 grouped digital inputs
- X2** – OR6: Assembly Group with 6 Output Relays (Changeover / Form C)
- X3** – TI: Standard current measuring card
- X4** – TU-OR5: Voltage measuring (0 ... 300 VAC) assembly group with 5 additional Output Relays (NO / Form A)
- X5** – DI8-OR4: Assembly Group with 8 Digital Inputs and 4 Output Relays (NO / Form A)
- X6** – DI8-OR4: Assembly Group with 8 Digital Inputs and 4 Output Relays (NO / Form A)
- X103** – Profibus-DP, RS485, D-SUB
- X104** – IRIG-B00X, incl. System Contact (Supervision Contact)

MRA4-2E0BFA

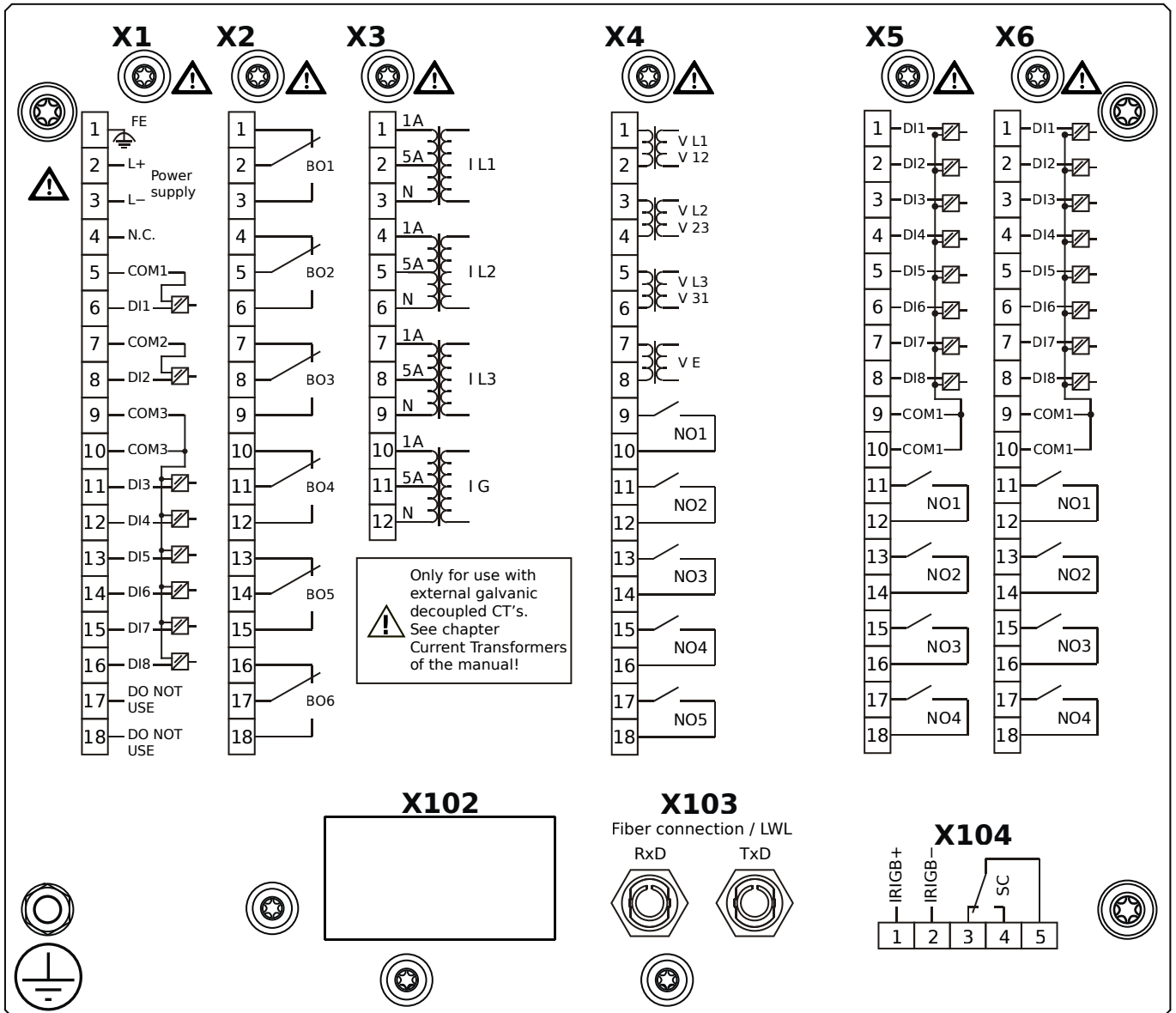

Housing B2, small display, 19" rack mounting

- X1** – DI8-X1: Wide-range power supply unit, incl. 2 non-grouped digital inputs and 6 grouped digital inputs
- X2** – OR6: Assembly Group with 6 Output Relays (Changeover / Form C)
- X3** – TI: Standard current measuring card
- X4** – TU-OR5: Voltage measuring (0 ... 300 VAC) assembly group with 5 additional Output Relays (NO / Form A)
- X5** – DI8-OR4: Assembly Group with 8 Digital Inputs and 4 Output Relays (NO / Form A)
- X6** – DI8-OR4: Assembly Group with 8 Digital Inputs and 4 Output Relays (NO / Form A)
- X103** – Modbus RTU / IEC 60870-5-103 / DNP3.0 RTU, Fiber optics interface, ST Connector
- X104** – IRIG-B00X, incl. System Contact (Supervision Contact)

MRA4-2E0BFB

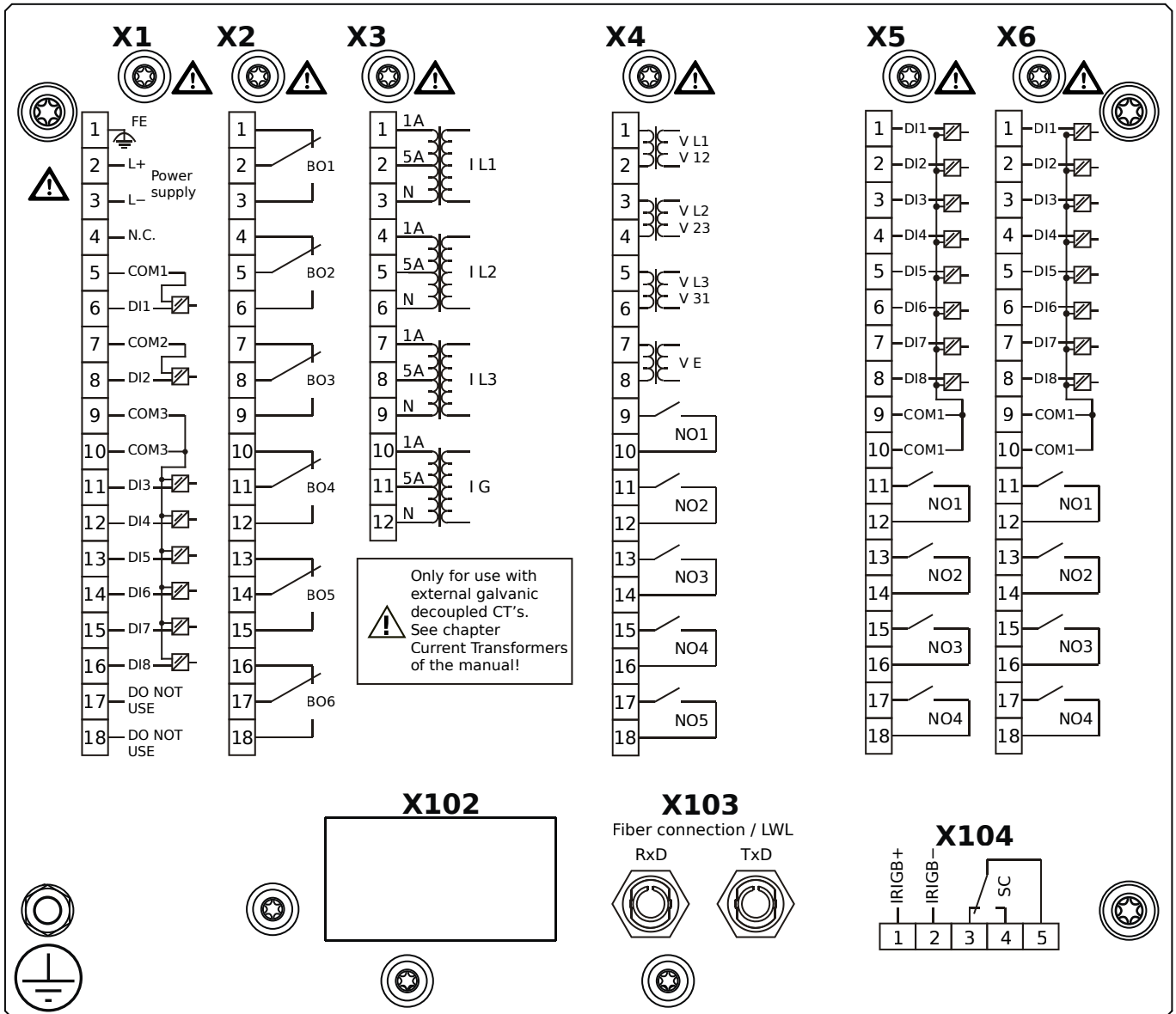

Housing B2, small display, 19" rack mounting

- + Conformal Coating (for installations in harsh environment)

- X1** – DI8-X1: Wide-range power supply unit, incl. 2 non-grouped digital inputs and 6 grouped digital inputs
- X2** – OR6: Assembly Group with 6 Output Relays (Changeover / Form C)
- X3** – TI: Standard current measuring card
- X4** – TU-OR5: Voltage measuring (0 ... 300 VAC) assembly group with 5 additional Output Relays (NO / Form A)
- X5** – DI8-OR4: Assembly Group with 8 Digital Inputs and 4 Output Relays (NO / Form A)
- X6** – DI8-OR4: Assembly Group with 8 Digital Inputs and 4 Output Relays (NO / Form A)
- X103** – Modbus RTU / IEC 60870-5-103 / DNP3.0 RTU, Fiber optics interface, ST Connector
- X104** – IRIG-B00X, incl. System Contact (Supervision Contact)

MRA4-2E0BGA

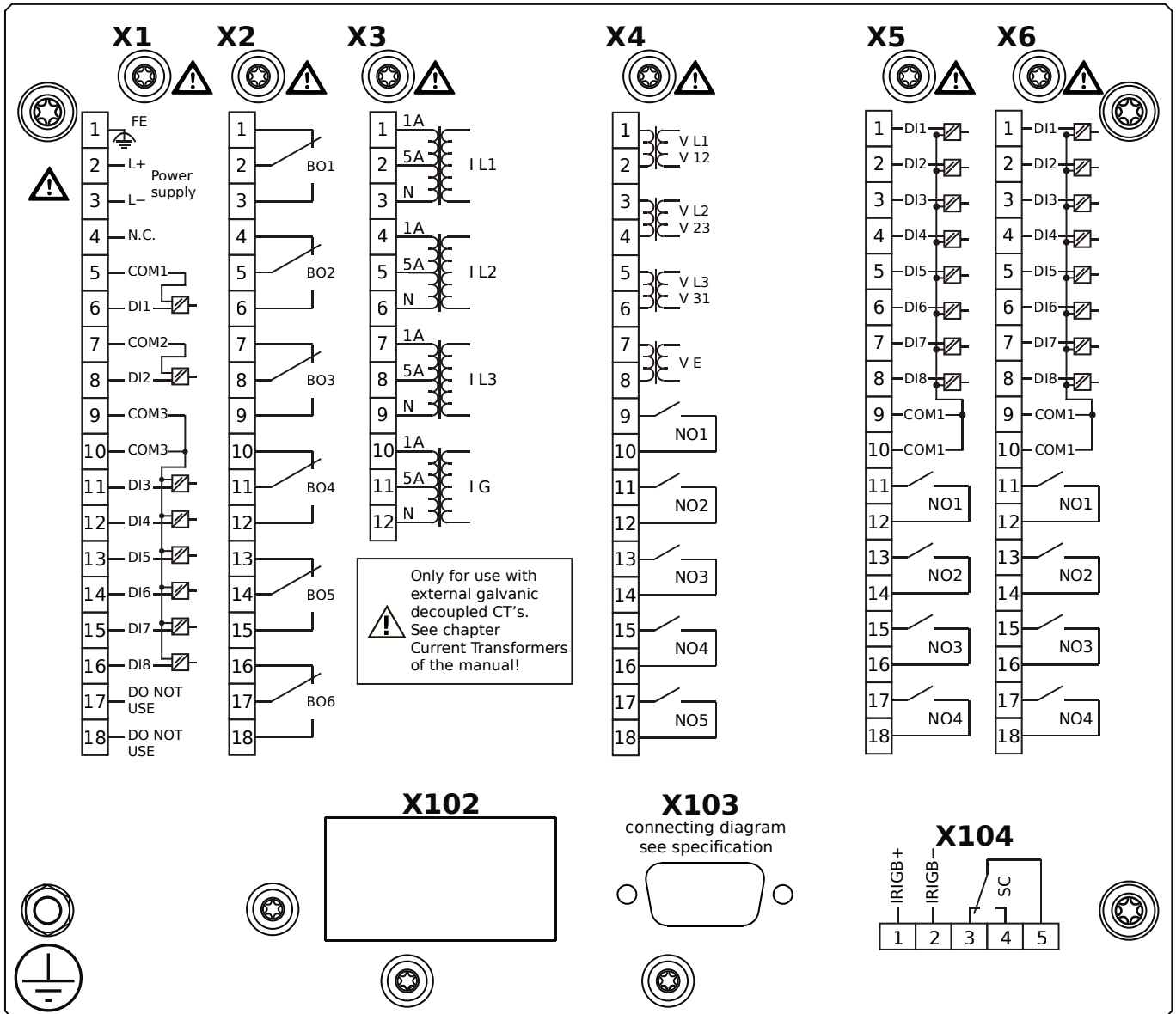

Housing B2, small display, 19" rack mounting

- X1** – DI8-X1: Wide-range power supply unit, incl. 2 non-grouped digital inputs and 6 grouped digital inputs
- X2** – OR6: Assembly Group with 6 Output Relays (Changeover / Form C)
- X3** – TI: Standard current measuring card
- X4** – TU-OR5: Voltage measuring (0 ... 300 VAC) assembly group with 5 additional Output Relays (NO / Form A)
- X5** – DI8-OR4: Assembly Group with 8 Digital Inputs and 4 Output Relays (NO / Form A)
- X6** – DI8-OR4: Assembly Group with 8 Digital Inputs and 4 Output Relays (NO / Form A)
- X103** – Modbus RTU / IEC 60870-5-103 / DNP3.0 RTU, RS485, D-SUB
- X104** – IRIG-B00X, incl. System Contact (Supervision Contact)

MRA4-2E0BGB

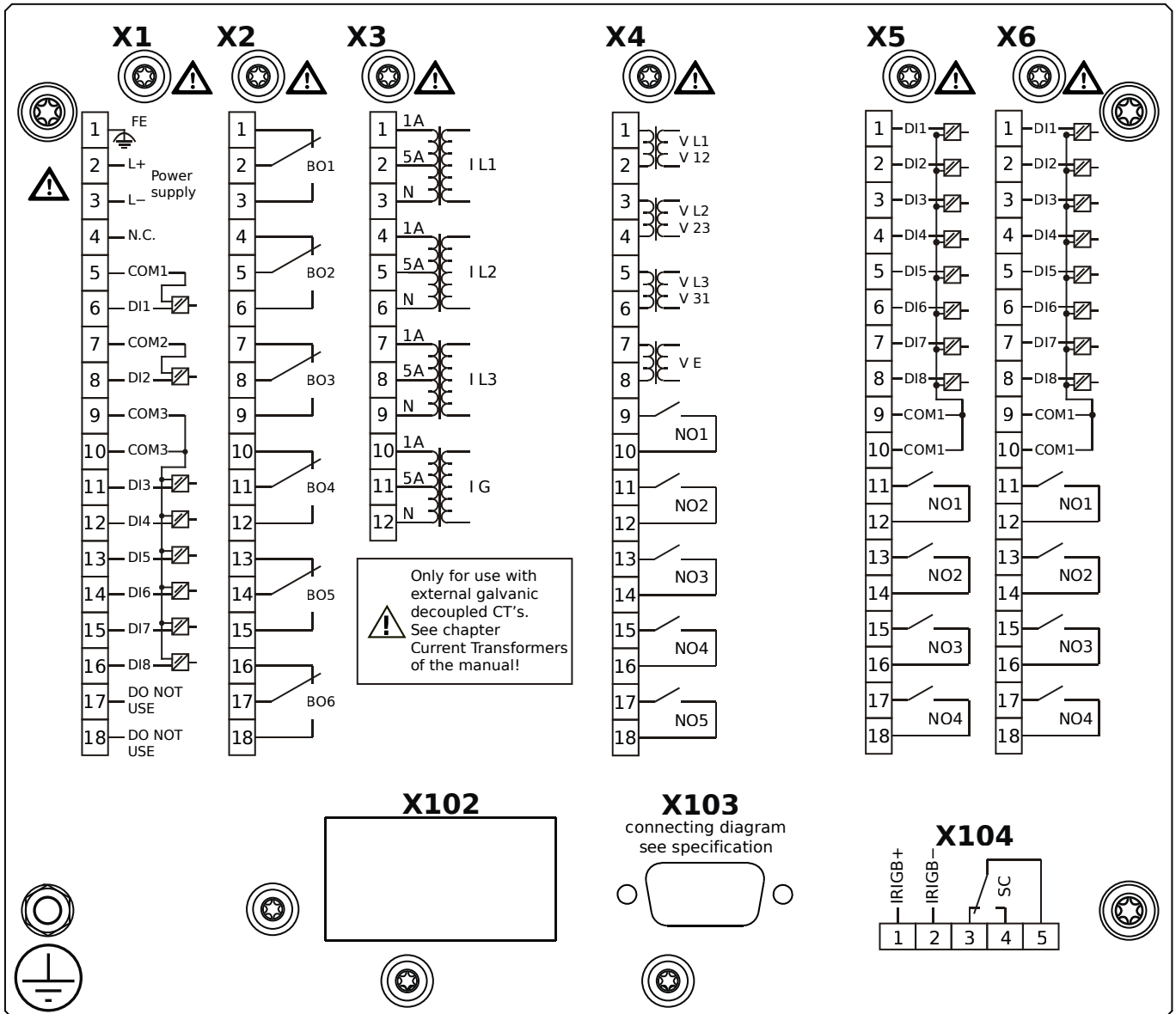

Housing B2, small display, 19" rack mounting

+ Conformal Coating (for installations in harsh environment)

- X1** – DI8-X1: Wide-range power supply unit, incl. 2 non-grouped digital inputs and 6 grouped digital inputs
- X2** – OR6: Assembly Group with 6 Output Relays (Changeover / Form C)
- X3** – TI: Standard current measuring card
- X4** – TU-OR5: Voltage measuring (0 ... 300 VAC) assembly group with 5 additional Output Relays (NO / Form A)
- X5** – DI8-OR4: Assembly Group with 8 Digital Inputs and 4 Output Relays (NO / Form A)
- X6** – DI8-OR4: Assembly Group with 8 Digital Inputs and 4 Output Relays (NO / Form A)
- X103** – Modbus RTU / IEC 60870-5-103 / DNP3.0 RTU, RS485, D-SUB
- X104** – IRIG-B00X, incl. System Contact (Supervision Contact)

MRA4-2E0BHA

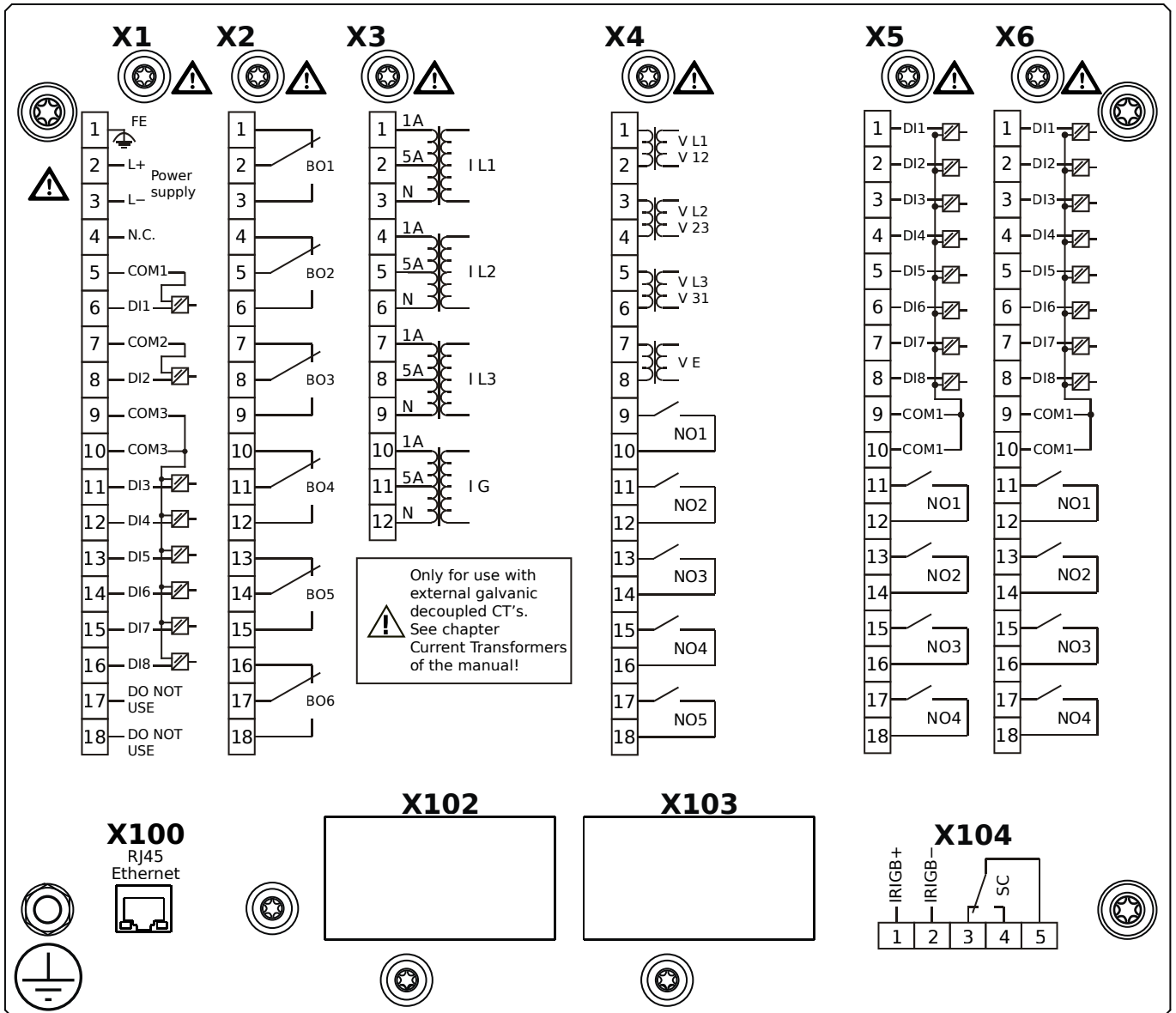

Housing B2, small display, 19" rack mounting

- X1** – DI8-X1: Wide-range power supply unit, incl. 2 non-grouped digital inputs and 6 grouped digital inputs
- X2** – OR6: Assembly Group with 6 Output Relays (Changeover / Form C)
- X3** – TI: Standard current measuring card
- X4** – TU-OR5: Voltage measuring (0 ... 300 VAC) assembly group with 5 additional Output Relays (NO / Form A)
- X5** – DI8-OR4: Assembly Group with 8 Digital Inputs and 4 Output Relays (NO / Form A)
- X6** – DI8-OR4: Assembly Group with 8 Digital Inputs and 4 Output Relays (NO / Form A)
- X100** – IEC 61850 / Modbus TCP / DNP3.0 TCP/UDP, Ethernet interface, 100 Mbit/s, RJ45 (BASE100-FX)
- X104** – IRIG-B00X, incl. System Contact (Supervision Contact)

MRA4-2E0BHB

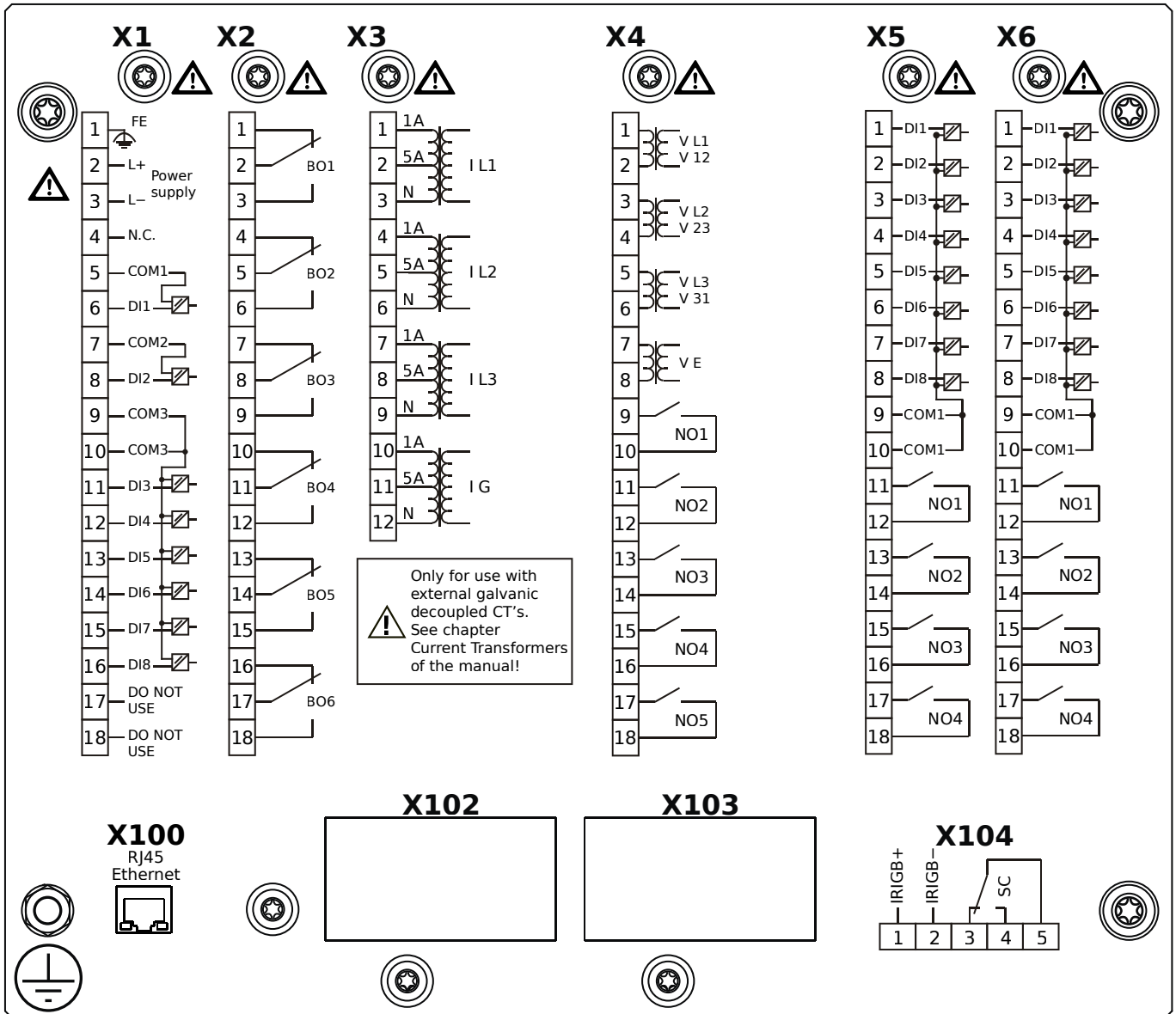

Housing B2, small display, 19" rack mounting

+ Conformal Coating (for installations in harsh environment)

- X1** – DI8-X1: Wide-range power supply unit, incl. 2 non-grouped digital inputs and 6 grouped digital inputs
- X2** – OR6: Assembly Group with 6 Output Relays (Changeover / Form C)
- X3** – TI: Standard current measuring card
- X4** – TU-OR5: Voltage measuring (0 ... 300 VAC) assembly group with 5 additional Output Relays (NO / Form A)
- X5** – DI8-OR4: Assembly Group with 8 Digital Inputs and 4 Output Relays (NO / Form A)
- X6** – DI8-OR4: Assembly Group with 8 Digital Inputs and 4 Output Relays (NO / Form A)
- X100** – IEC 61850 / Modbus TCP / DNP3.0 TCP/UDP, Ethernet interface, 100 Mbit/s, RJ45 (BASE100-FX)
- X104** – IRIG-B00X, incl. System Contact (Supervision Contact)

MRA4-2E0BIA

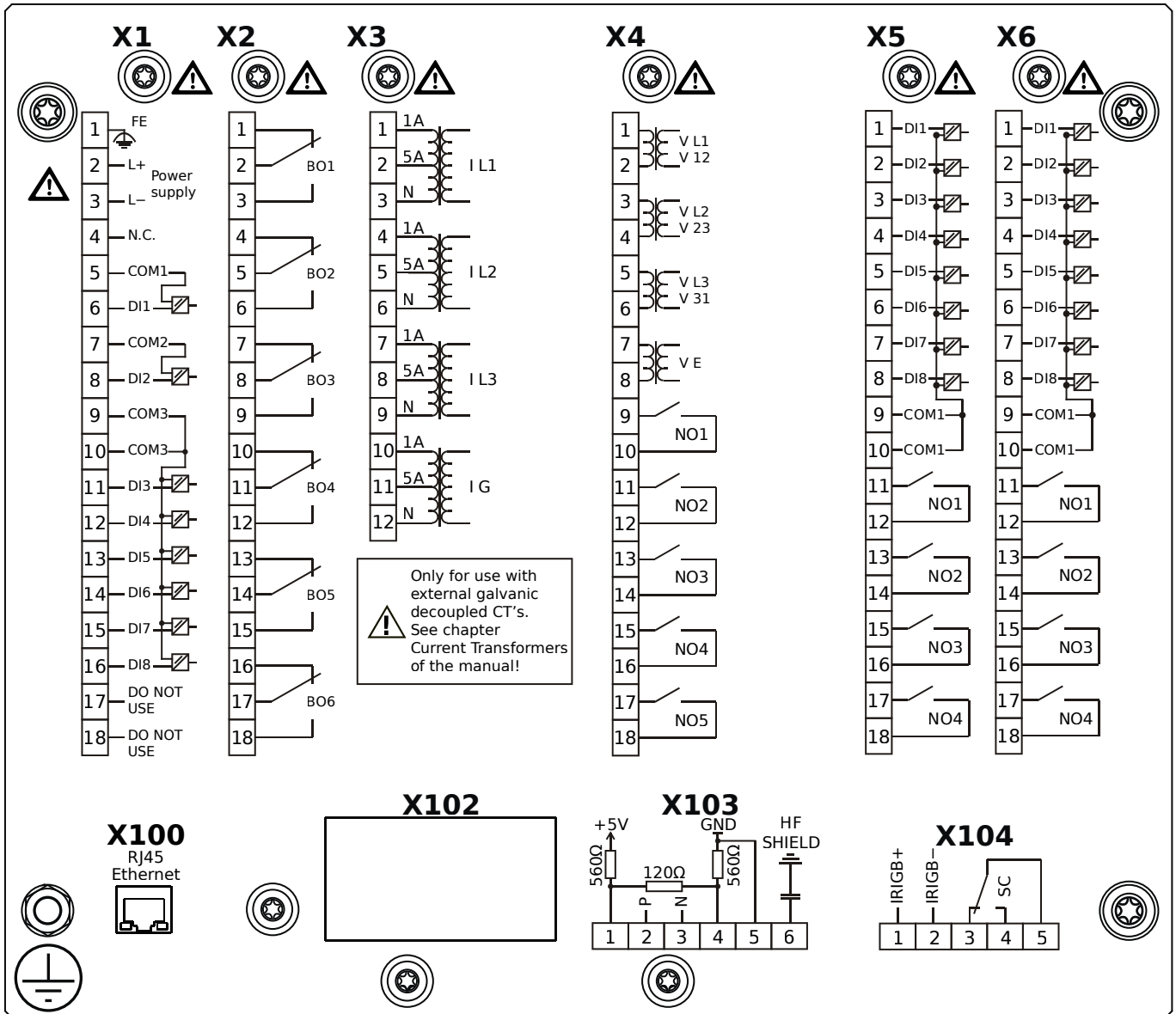

Housing B2, small display, 19" rack mounting

- X1** – DI8-X1: Wide-range power supply unit, incl. 2 non-grouped digital inputs and 6 grouped digital inputs
- X2** – OR6: Assembly Group with 6 Output Relays (Changeover / Form C)
- X3** – TI: Standard current measuring card
- X4** – TU-OR5: Voltage measuring (0 ... 300 VAC) assembly group with 5 additional Output Relays (NO / Form A)
- X5** – DI8-OR4: Assembly Group with 8 Digital Inputs and 4 Output Relays (NO / Form A)
- X6** – DI8-OR4: Assembly Group with 8 Digital Inputs and 4 Output Relays (NO / Form A)
- X100** – Modbus TCP / DNP3.0 TCP/UDP, Ethernet interface, 100 Mbit/s, RJ45 (BASE100-FX)
- X103** – IEC 60870-5-103 / Modbus RTU / DNP3.0 RTU, RS485, Terminals
- X104** – IRIG-B00X, incl. System Contact (Supervision Contact)

MRA4-2E0BIB

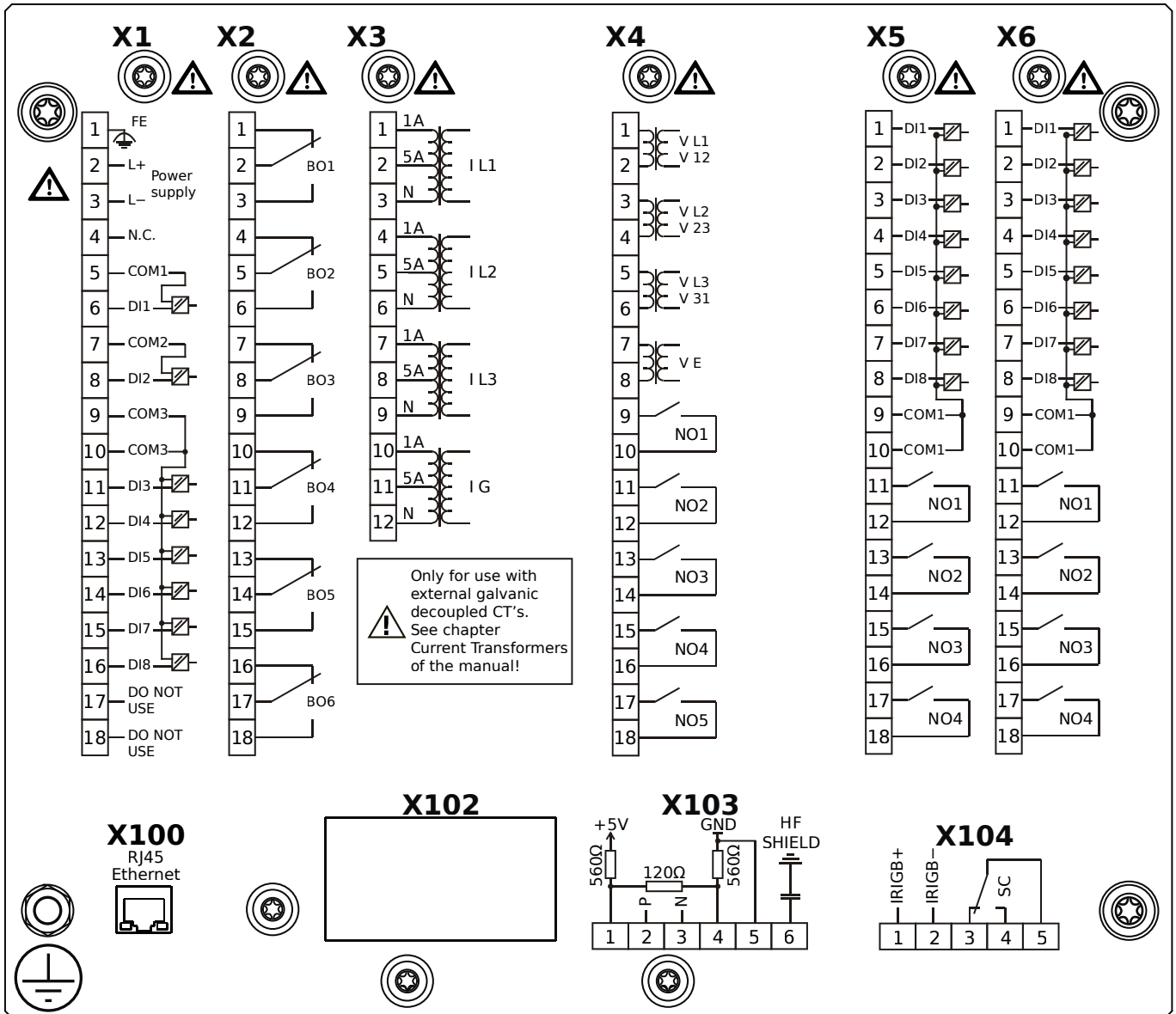

Housing B2, small display, 19" rack mounting

+ Conformal Coating (for installations in harsh environment)

- X1** – DI8-X1: Wide-range power supply unit, incl. 2 non-grouped digital inputs and 6 grouped digital inputs
- X2** – OR6: Assembly Group with 6 Output Relays (Changeover / Form C)
- X3** – TI: Standard current measuring card
- X4** – TU-OR5: Voltage measuring (0 ... 300 VAC) assembly group with 5 additional Output Relays (NO / Form A)
- X5** – DI8-OR4: Assembly Group with 8 Digital Inputs and 4 Output Relays (NO / Form A)
- X6** – DI8-OR4: Assembly Group with 8 Digital Inputs and 4 Output Relays (NO / Form A)
- X100** – Modbus TCP / DNP3.0 TCP/UDP, Ethernet interface, 100 Mbit/s, RJ45 (BASE100-FX)
- X103** – IEC 60870-5-103 / Modbus RTU / DNP3.0 RTU, RS485, Terminals
- X104** – IRIG-B00X, incl. System Contact (Supervision Contact)

MRA4-2E0BKA

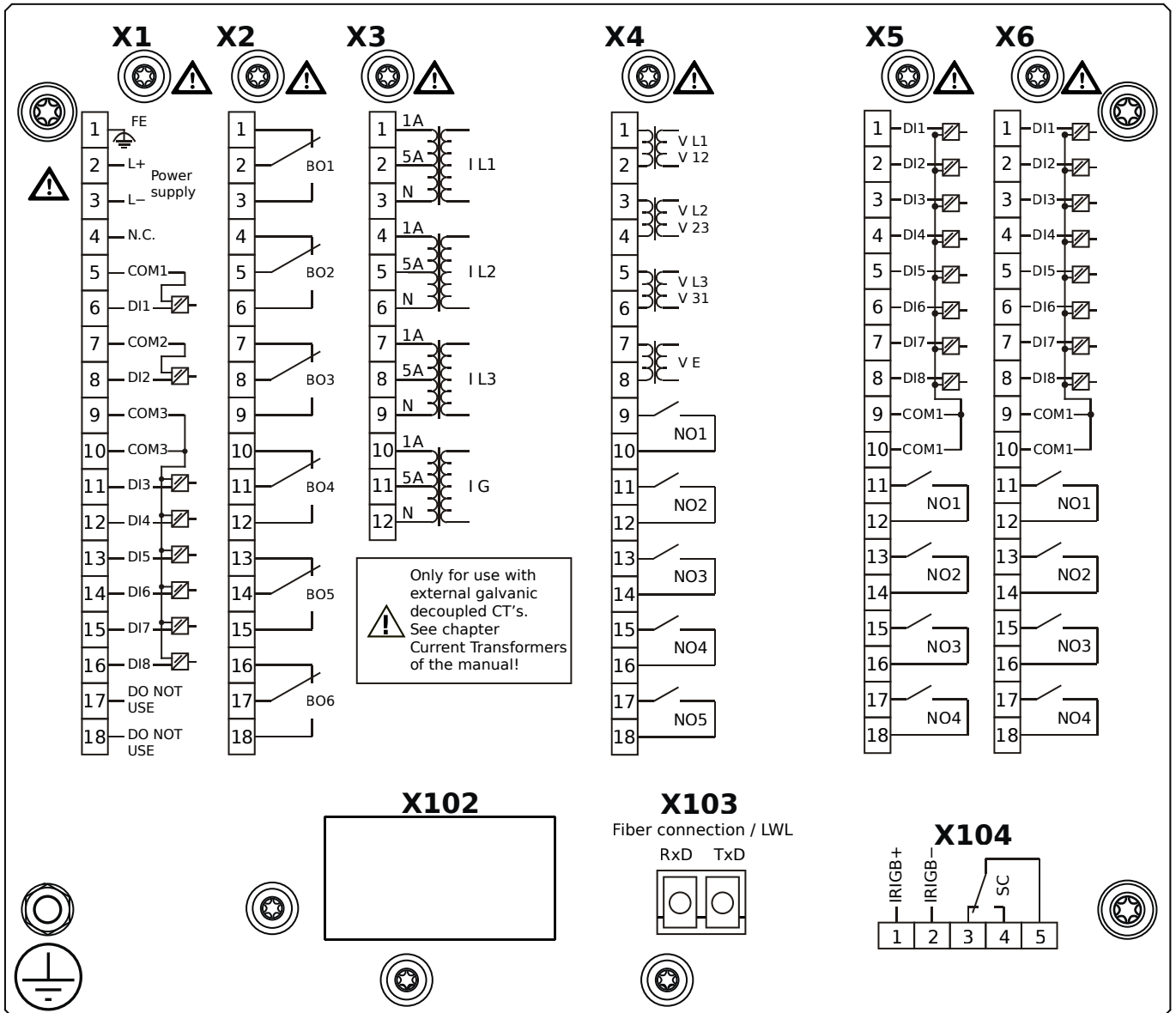

Housing B2, small display, 19" rack mounting

- X1** – DI8-X1: Wide-range power supply unit, incl. 2 non-grouped digital inputs and 6 grouped digital inputs
- X2** – OR6: Assembly Group with 6 Output Relays (Changeover / Form C)
- X3** – TI: Standard current measuring card
- X4** – TU-OR5: Voltage measuring (0 ... 300 VAC) assembly group with 5 additional Output Relays (NO / Form A)
- X5** – DI8-OR4: Assembly Group with 8 Digital Inputs and 4 Output Relays (NO / Form A)
- X6** – DI8-OR4: Assembly Group with 8 Digital Inputs and 4 Output Relays (NO / Form A)
- X103** – IEC 61850 / Modbus TCP / DNP3.0 TCP/UDP, Fiber optics interface, LC Connector
- X104** – IRIGB-00X, incl. System Contact (Supervision Contact)

MRA4-2E0BKB

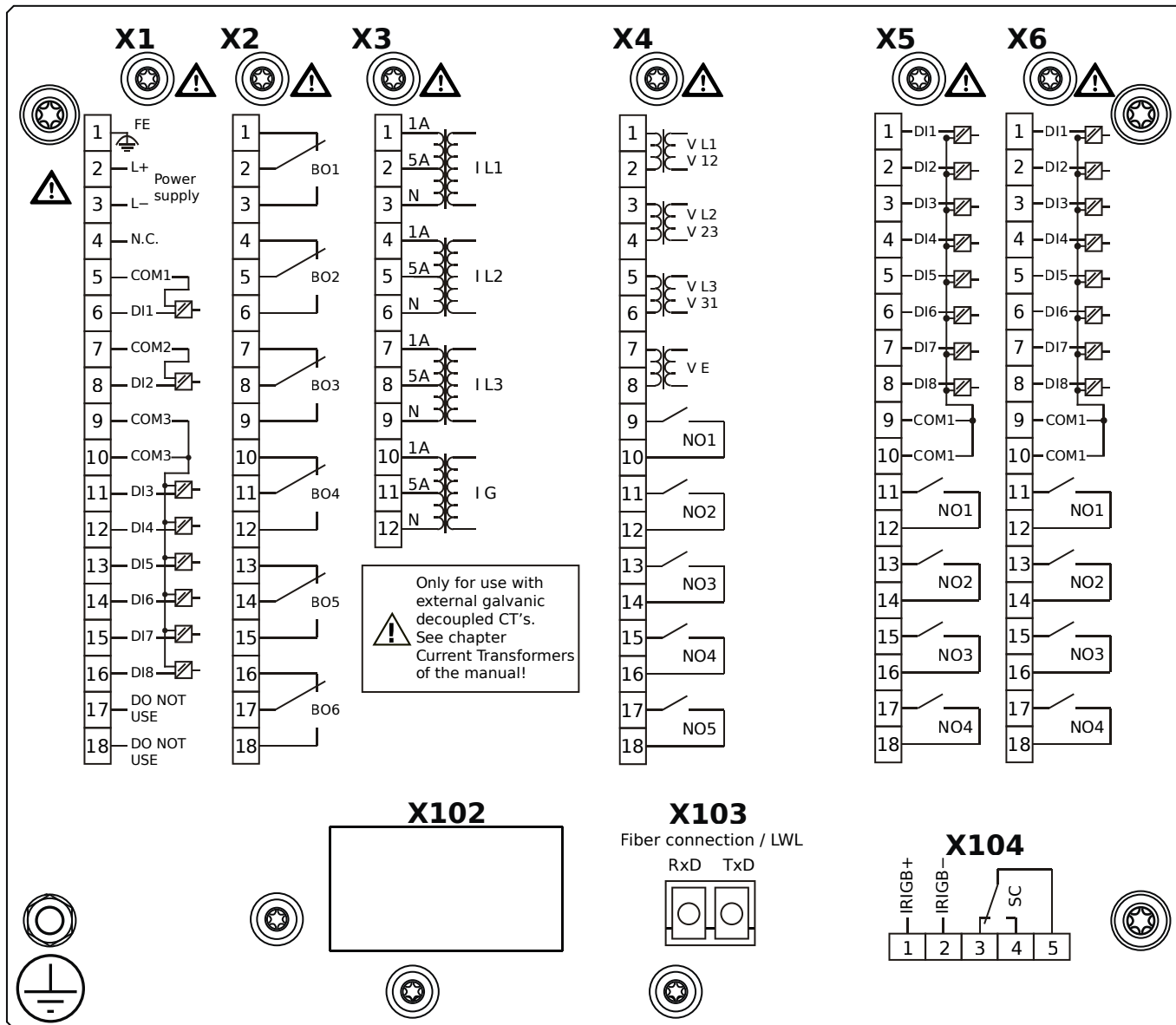

Housing B2, small display, 19" rack mounting

+ Conformal Coating (for installations in harsh environment)

- X1** – DI8-X1: Wide-range power supply unit, incl. 2 non-grouped digital inputs and 6 grouped digital inputs
- X2** – OR6: Assembly Group with 6 Output Relays (Changeover / Form C)
- X3** – TI: Standard current measuring card
- X4** – TU-OR5: Voltage measuring (0 ... 300 VAC) assembly group with 5 additional Output Relays (NO / Form A)
- X5** – DI8-OR4: Assembly Group with 8 Digital Inputs and 4 Output Relays (NO / Form A)
- X6** – DI8-OR4: Assembly Group with 8 Digital Inputs and 4 Output Relays (NO / Form A)
- X103** – IEC 61850 / Modbus TCP / DNP3.0 TCP/UDP, Fiber optics interface, LC Connector
- X104** – IRIG-B00X, incl. System Contact (Supervision Contact)

MRA4-2E0BLA

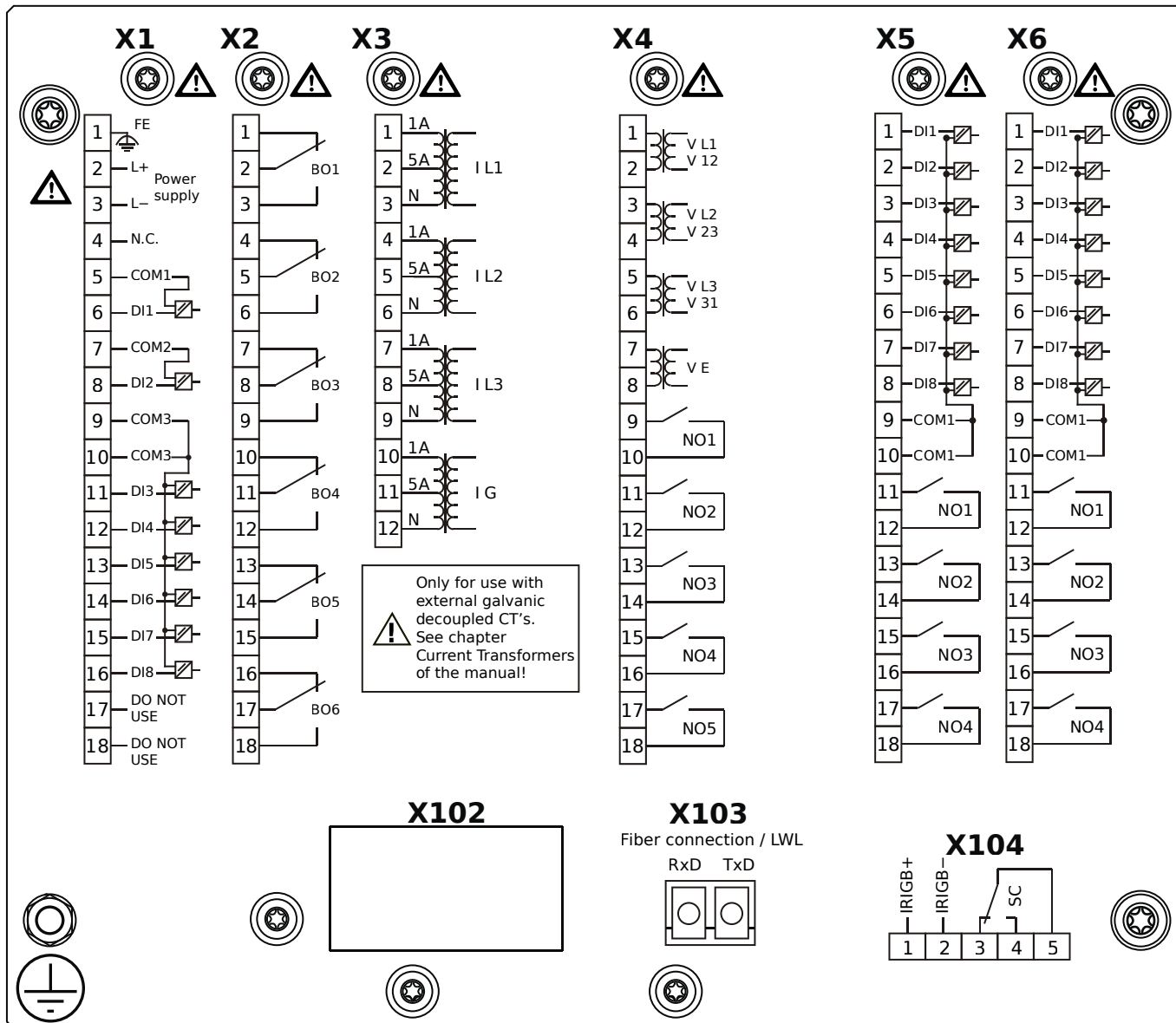

Housing B2, small display, 19" rack mounting

- X1** – DI8-X1: Wide-range power supply unit, incl. 2 non-grouped digital inputs and 6 grouped digital inputs
- X2** – OR6: Assembly Group with 6 Output Relays (Changeover / Form C)
- X3** – TI: Standard current measuring card
- X4** – TU-OR5: Voltage measuring (0 ... 300 VAC) assembly group with 5 additional Output Relays (NO / Form A)
- X5** – DI8-OR4: Assembly Group with 8 Digital Inputs and 4 Output Relays (NO / Form A)
- X6** – DI8-OR4: Assembly Group with 8 Digital Inputs and 4 Output Relays (NO / Form A)
- X103** – Modbus TCP / DNP3.0 TCP/UDP, Fiber optics interface, LC Connector
- X104** – IRIG-B00X, incl. System Contact (Supervision Contact)

MRA4-2E0BLB

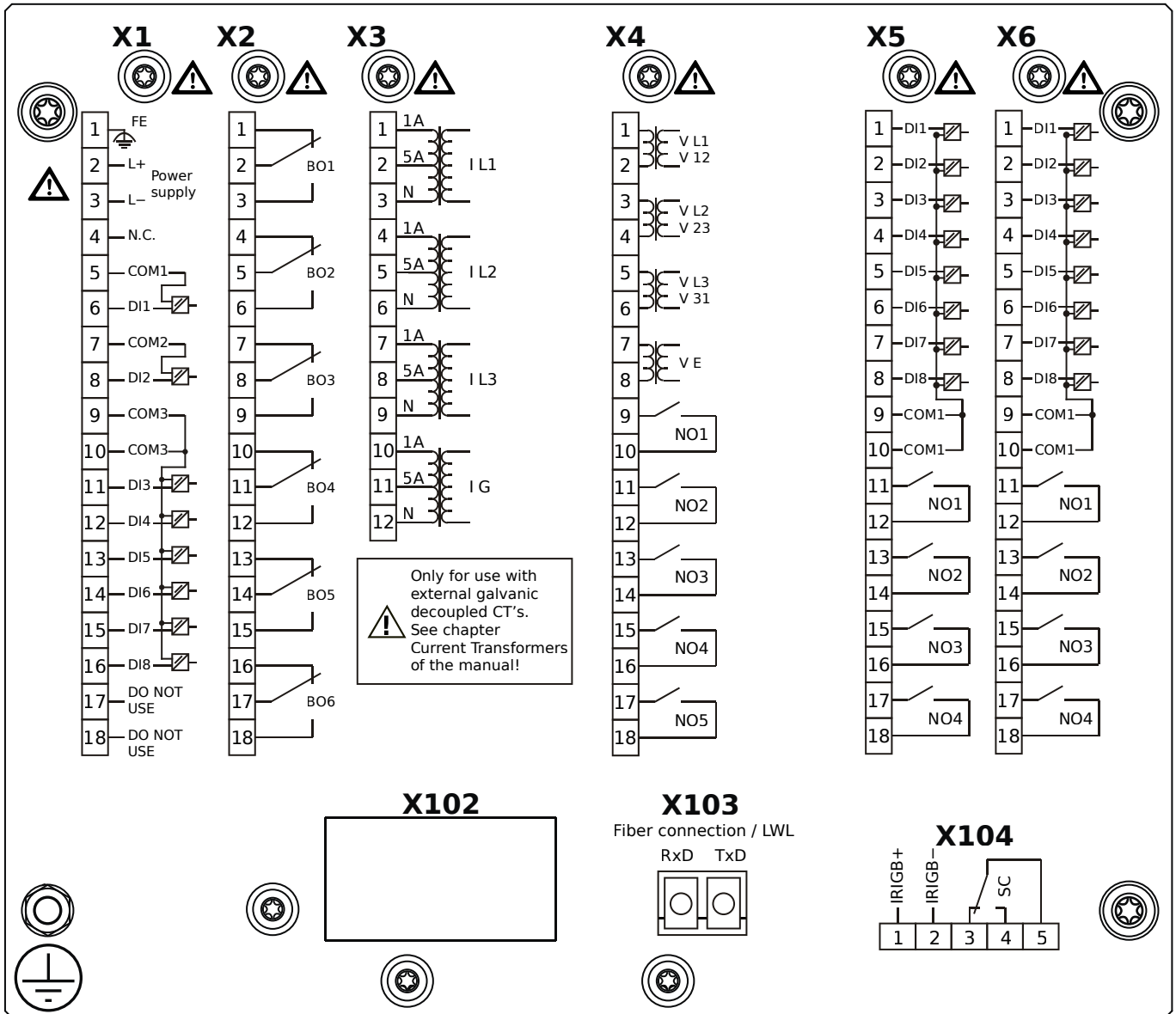

Housing B2, small display, 19" rack mounting

- + Conformal Coating (for installations in harsh environment)

- X1** – DI8-X1: Wide-range power supply unit, incl. 2 non-grouped digital inputs and 6 grouped digital inputs
- X2** – OR6: Assembly Group with 6 Output Relays (Changeover / Form C)
- X3** – TI: Standard current measuring card
- X4** – TU-OR5: Voltage measuring (0 ... 300 VAC) assembly group with 5 additional Output Relays (NO / Form A)
- X5** – DI8-OR4: Assembly Group with 8 Digital Inputs and 4 Output Relays (NO / Form A)
- X6** – DI8-OR4: Assembly Group with 8 Digital Inputs and 4 Output Relays (NO / Form A)
- X103** – Modbus TCP / DNP3.0 TCP/UDP, Fiber optics interface, LC Connector
- X104** – IRIG-B00X, incl. System Contact (Supervision Contact)

MRA4-2E0BTA

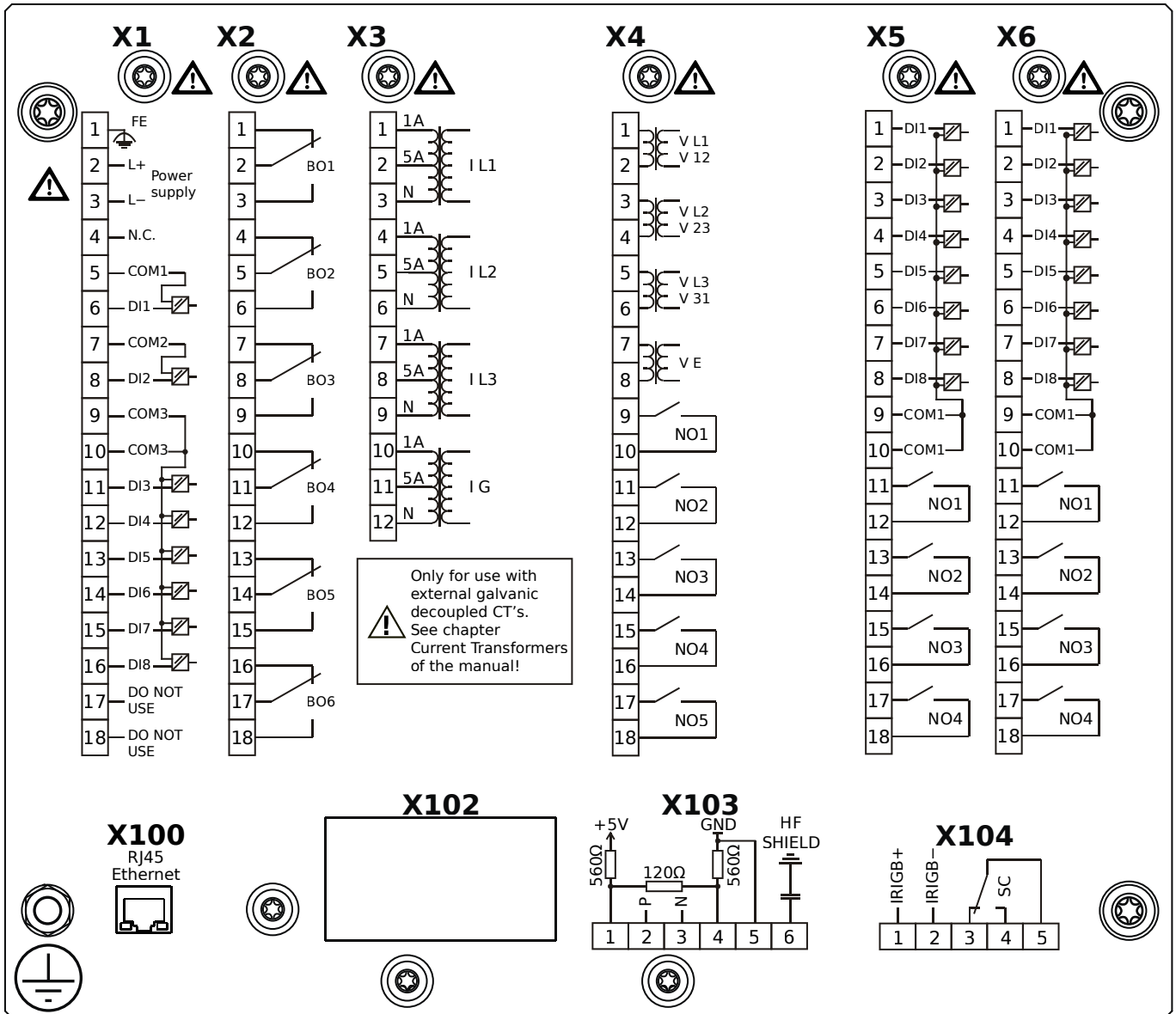

Housing B2, small display, 19" rack mounting

- X1** – DI8-X1: Wide-range power supply unit, incl. 2 non-grouped digital inputs and 6 grouped digital inputs
- X2** – OR6: Assembly Group with 6 Output Relays (Changeover / Form C)
- X3** – TI: Standard current measuring card
- X4** – TU-OR5: Voltage measuring (0 ... 300 VAC) assembly group with 5 additional Output Relays (NO / Form A)
- X5** – DI8-OR4: Assembly Group with 8 Digital Inputs and 4 Output Relays (NO / Form A)
- X6** – DI8-OR4: Assembly Group with 8 Digital Inputs and 4 Output Relays (NO / Form A)
- X100** – IEC 61850 / Modbus TCP / DNP3.0 TCP/UDP, Ethernet interface, 100 Mbit/s, RJ45 (BASE100-FX)
- X103** – IEC 60870-5-103 / Modbus RTU / DNP3.0 RTU, RS485, Terminals
- X104** – IRIG-B00X, incl. System Contact (Supervision Contact)

MRA4-2E0BTB

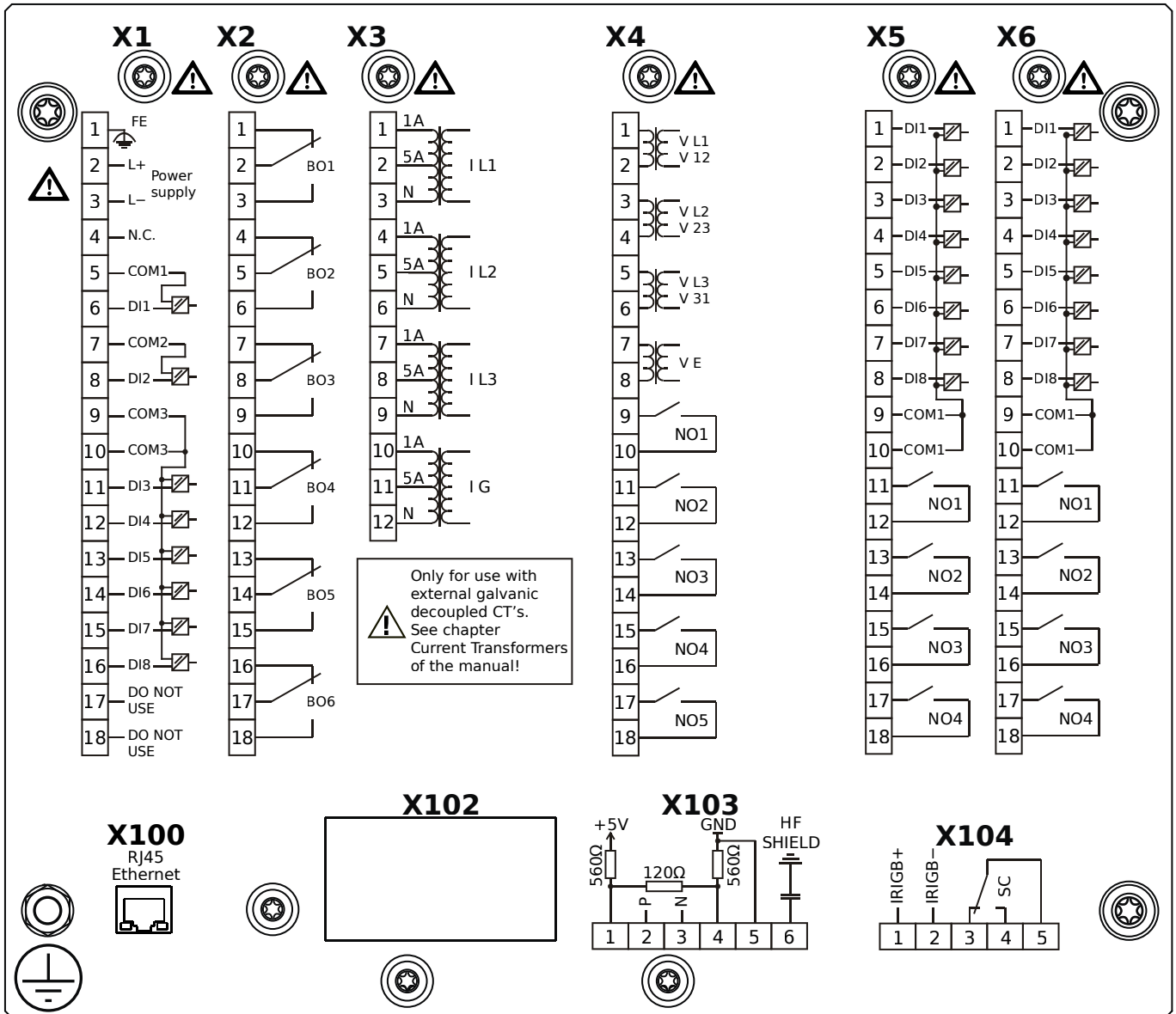

Housing B2, small display, 19" rack mounting

- + Conformal Coating (for installations in harsh environment)

- X1** – DI8-X1: Wide-range power supply unit, incl. 2 non-grouped digital inputs and 6 grouped digital inputs
- X2** – OR6: Assembly Group with 6 Output Relays (Changeover / Form C)
- X3** – TI: Standard current measuring card
- X4** – TU-OR5: Voltage measuring (0 ... 300 VAC) assembly group with 5 additional Output Relays (NO / Form A)
- X5** – DI8-OR4: Assembly Group with 8 Digital Inputs and 4 Output Relays (NO / Form A)
- X6** – DI8-OR4: Assembly Group with 8 Digital Inputs and 4 Output Relays (NO / Form A)
- X100** – IEC 61850 / Modbus TCP / DNP3.0 TCP/UDP, Ethernet interface, 100 Mbit/s, RJ45 (BASE100-FX)
- X103** – IEC 60870-5-103 / Modbus RTU / DNP3.0 RTU, RS485, Terminals
- X104** – IRIG-B00X, incl. System Contact (Supervision Contact)

MRA4-2E1AAA

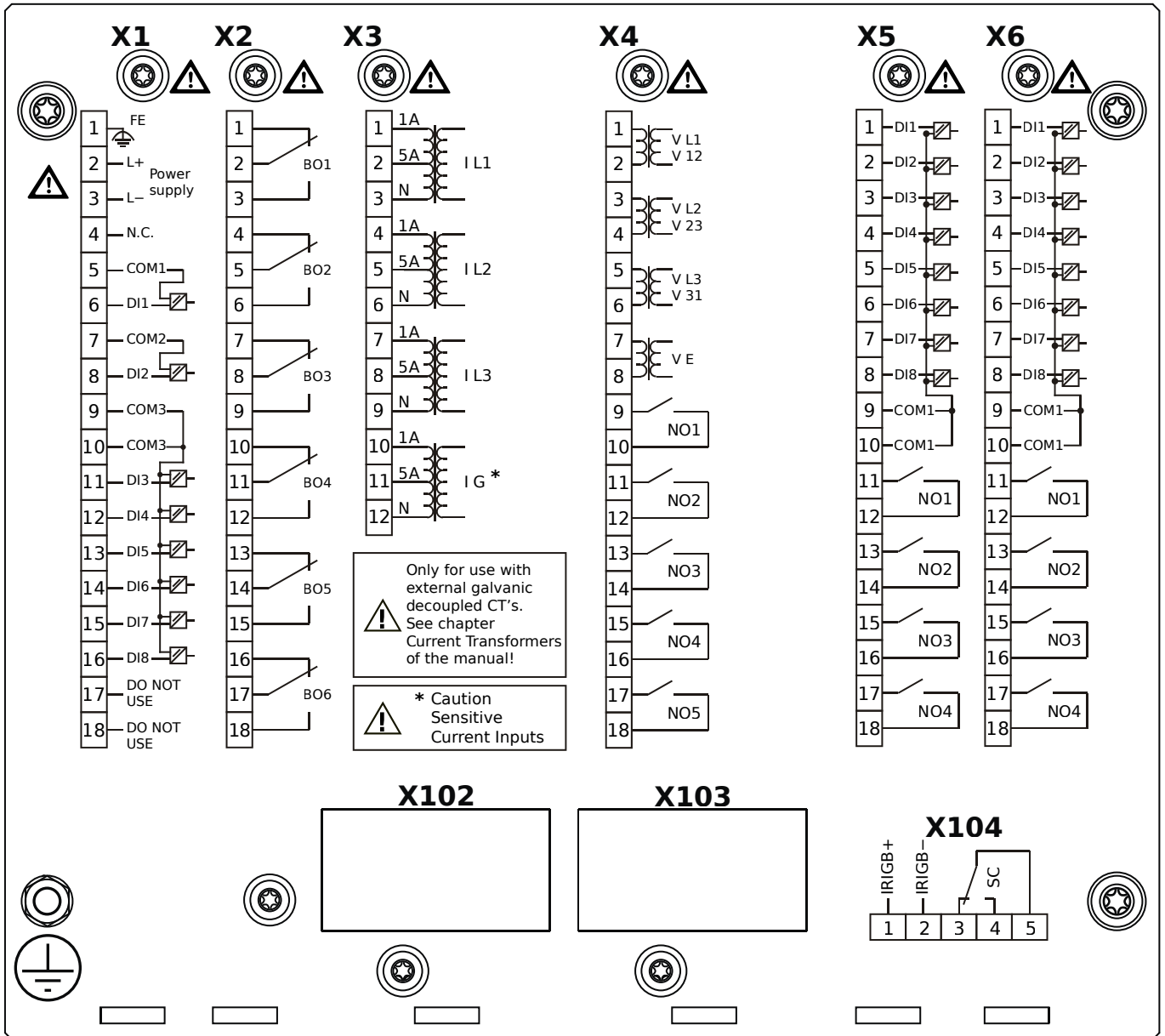

Housing B2, small display, door mounting

- X1** – DI8-X1: Wide-range power supply unit, incl. 2 non-grouped digital inputs and 6 grouped digital inputs
- X2** – OR6: Assembly Group with 6 Output Relays (Changeover / Form C)
- X3** – TIs: Standard phase current measuring card and sensitive ground current measuring
- X4** – TU-OR5: Voltage measuring (0 ... 300 VAC) assembly group with 5 additional Output Relays (NO / Form A)
- X5** – DI8-OR4: Assembly Group with 8 Digital Inputs and 4 Output Relays (NO / Form A)
- X6** – DI8-OR4: Assembly Group with 8 Digital Inputs and 4 Output Relays (NO / Form A)
- X104** – IRIG-B00X, incl. System Contact (Supervision Contact)

MRA4-2E1AAB

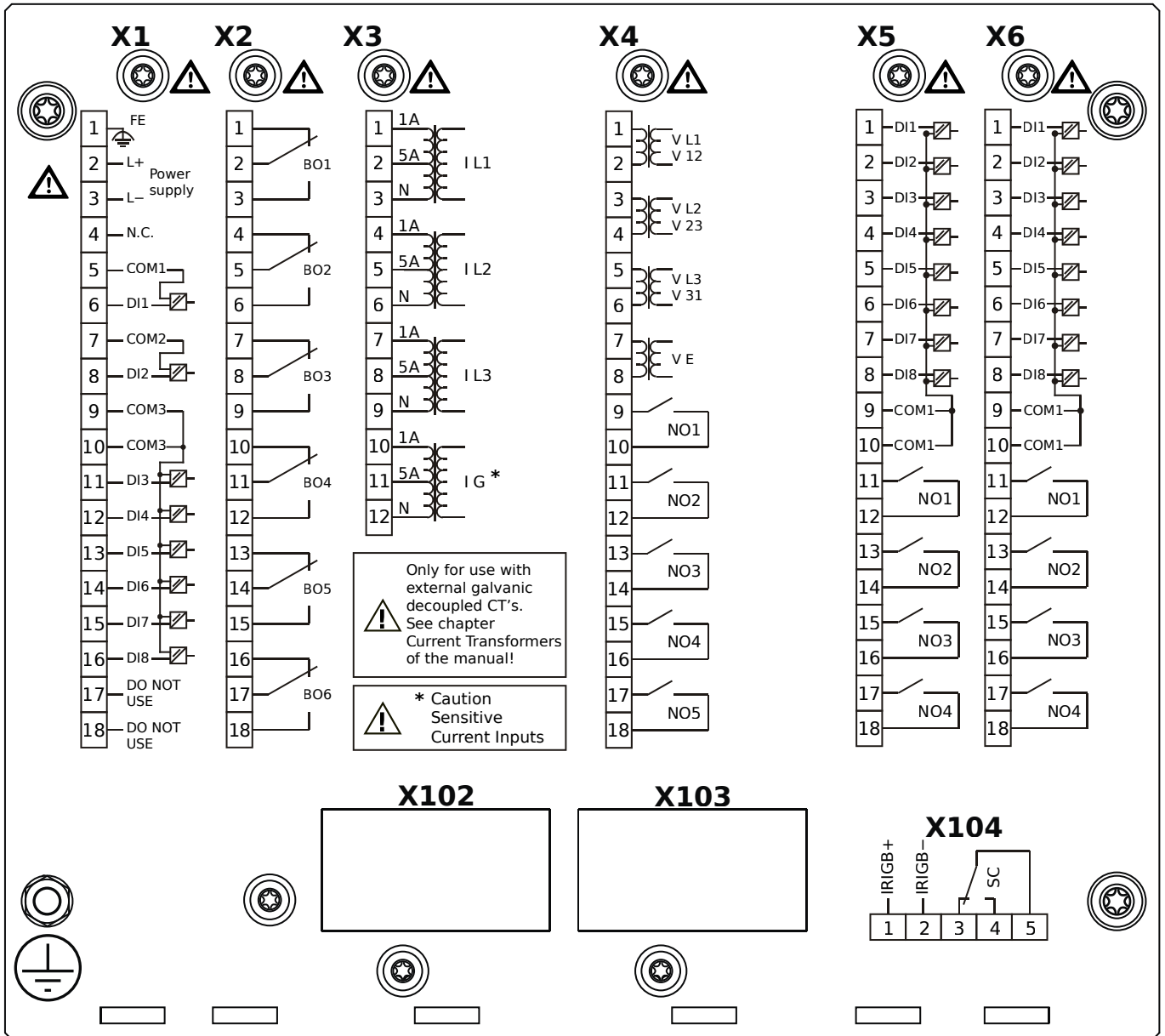

Housing B2, small display, door mounting

+ Conformal Coating (for installations in harsh environment)

- X1** – DI8-X1: Wide-range power supply unit, incl. 2 non-grouped digital inputs and 6 grouped digital inputs
- X2** – OR6: Assembly Group with 6 Output Relays (Changeover / Form C)
- X3** – TIs: Standard phase current measuring card and sensitive ground current measuring
- X4** – TU-OR5: Voltage measuring (0 ... 300 VAC) assembly group with 5 additional Output Relays (NO / Form A)
- X5** – DI8-OR4: Assembly Group with 8 Digital Inputs and 4 Output Relays (NO / Form A)
- X6** – DI8-OR4: Assembly Group with 8 Digital Inputs and 4 Output Relays (NO / Form A)
- X104** – IRIG-B00X, incl. System Contact (Supervision Contact)

MRA4-2E1ABA

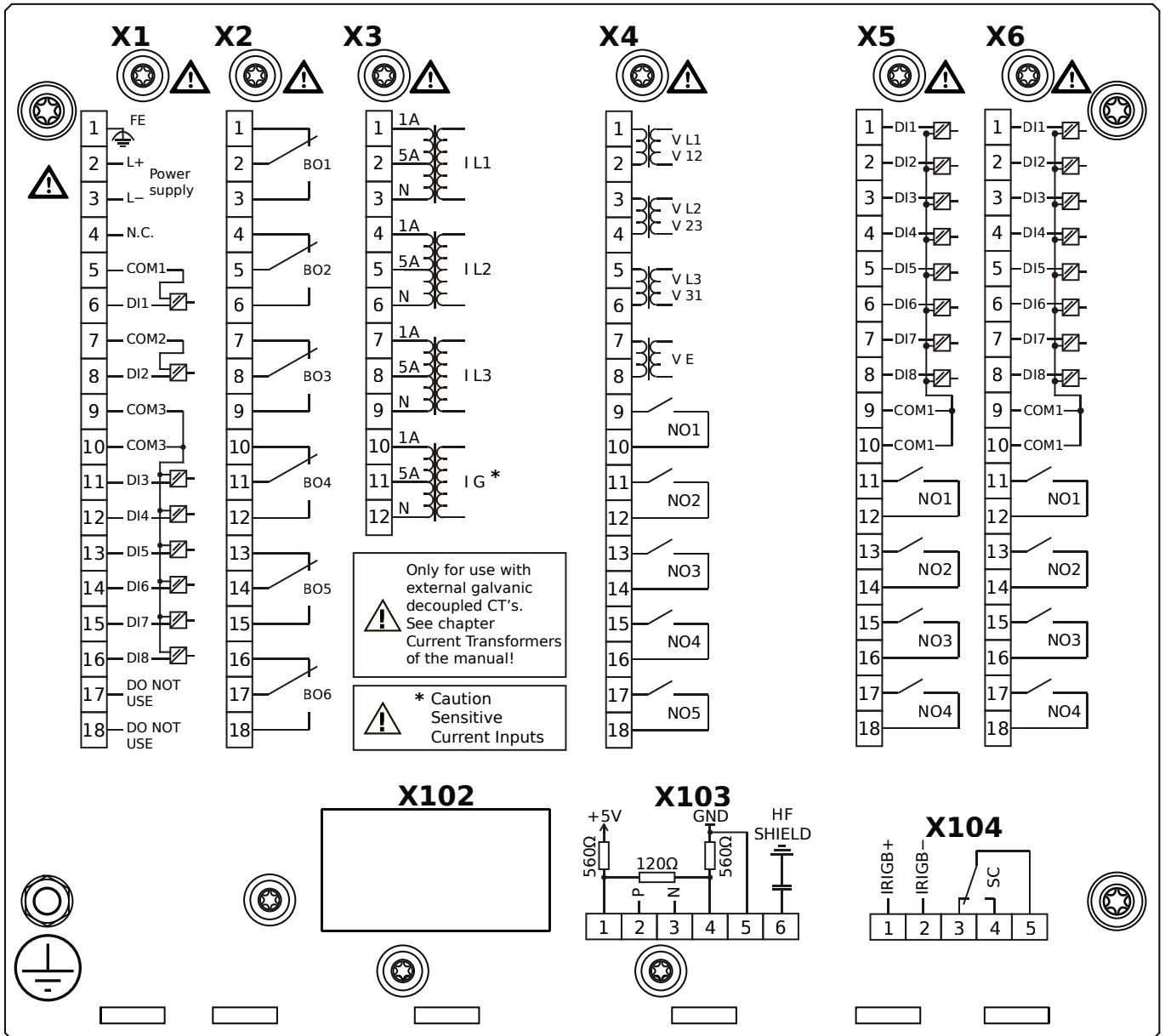

Housing B2, small display, door mounting

- X1** – DI8-X1: Wide-range power supply unit, incl. 2 non-grouped digital inputs and 6 grouped digital inputs
- X2** – OR6: Assembly Group with 6 Output Relays (Changeover / Form C)
- X3** – TIs: Standard phase current measuring card and sensitive ground current measuring
- X4** – TU-OR5: Voltage measuring (0 ... 300 VAC) assembly group with 5 additional Output Relays (NO / Form A)
- X5** – DI8-OR4: Assembly Group with 8 Digital Inputs and 4 Output Relays (NO / Form A)
- X6** – DI8-OR4: Assembly Group with 8 Digital Inputs and 4 Output Relays (NO / Form A)
- X103** – Modbus RTU / IEC 60870-5-103 / DNP3.0 RTU, RS485, Terminals
- X104** – IRIG-B00X, incl. System Contact (Supervision Contact)

MRA4-2E1ABB

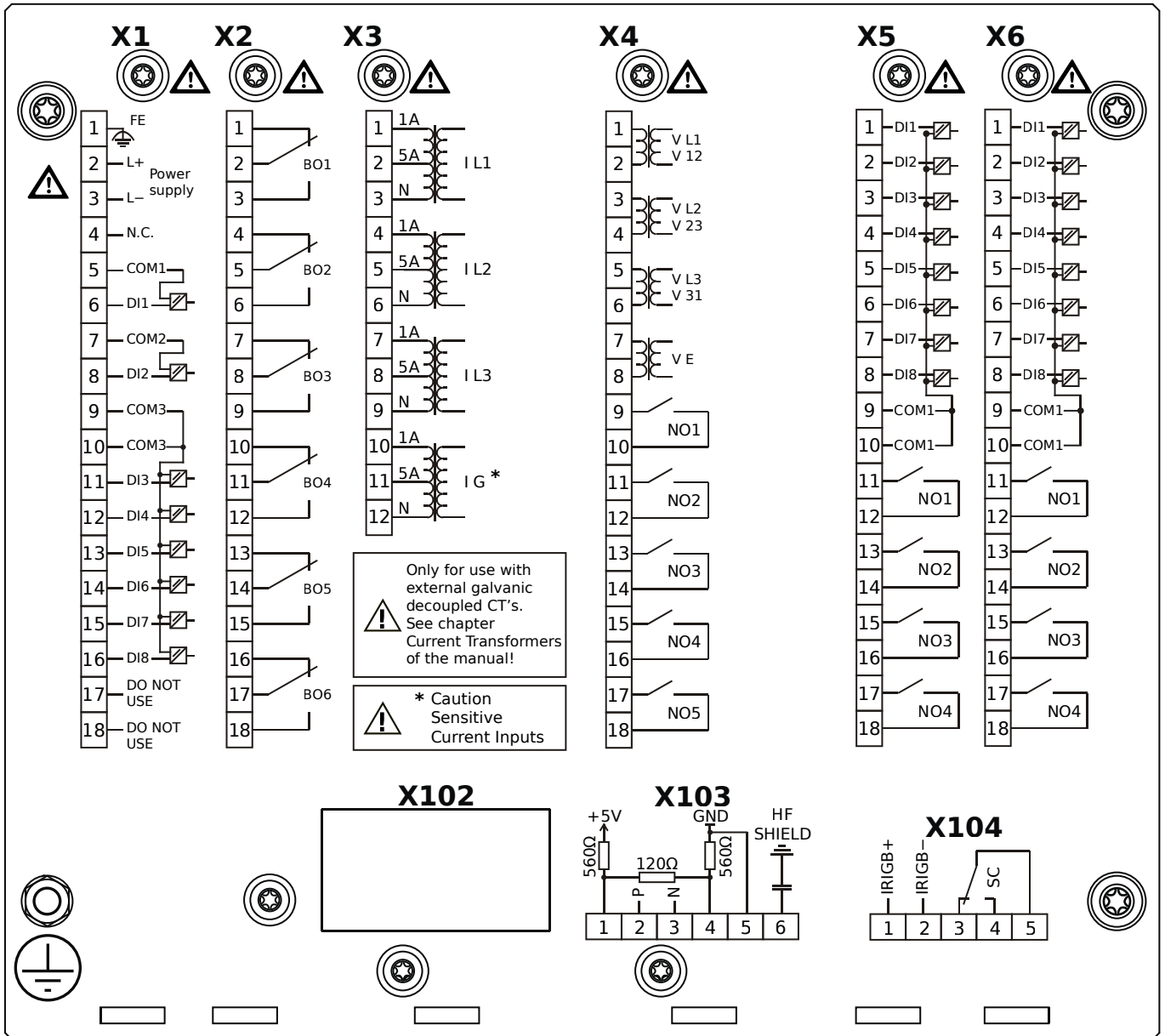

Housing B2, small display, door mounting

+ Conformal Coating (for installations in harsh environment)

- X1** – DI8-X1: Wide-range power supply unit, incl. 2 non-grouped digital inputs and 6 grouped digital inputs
- X2** – OR6: Assembly Group with 6 Output Relays (Changeover / Form C)
- X3** – TIs: Standard phase current measuring card and sensitive ground current measuring
- X4** – TU-OR5: Voltage measuring (0 ... 300 VAC) assembly group with 5 additional Output Relays (NO / Form A)
- X5** – DI8-OR4: Assembly Group with 8 Digital Inputs and 4 Output Relays (NO / Form A)
- X6** – DI8-OR4: Assembly Group with 8 Digital Inputs and 4 Output Relays (NO / Form A)
- X103** – Modbus RTU / IEC 60870-5-103 / DNP3.0 RTU, RS485, Terminals
- X104** – IREG-B00X, incl. System Contact (Supervision Contact)

MRA4-2E1ACA

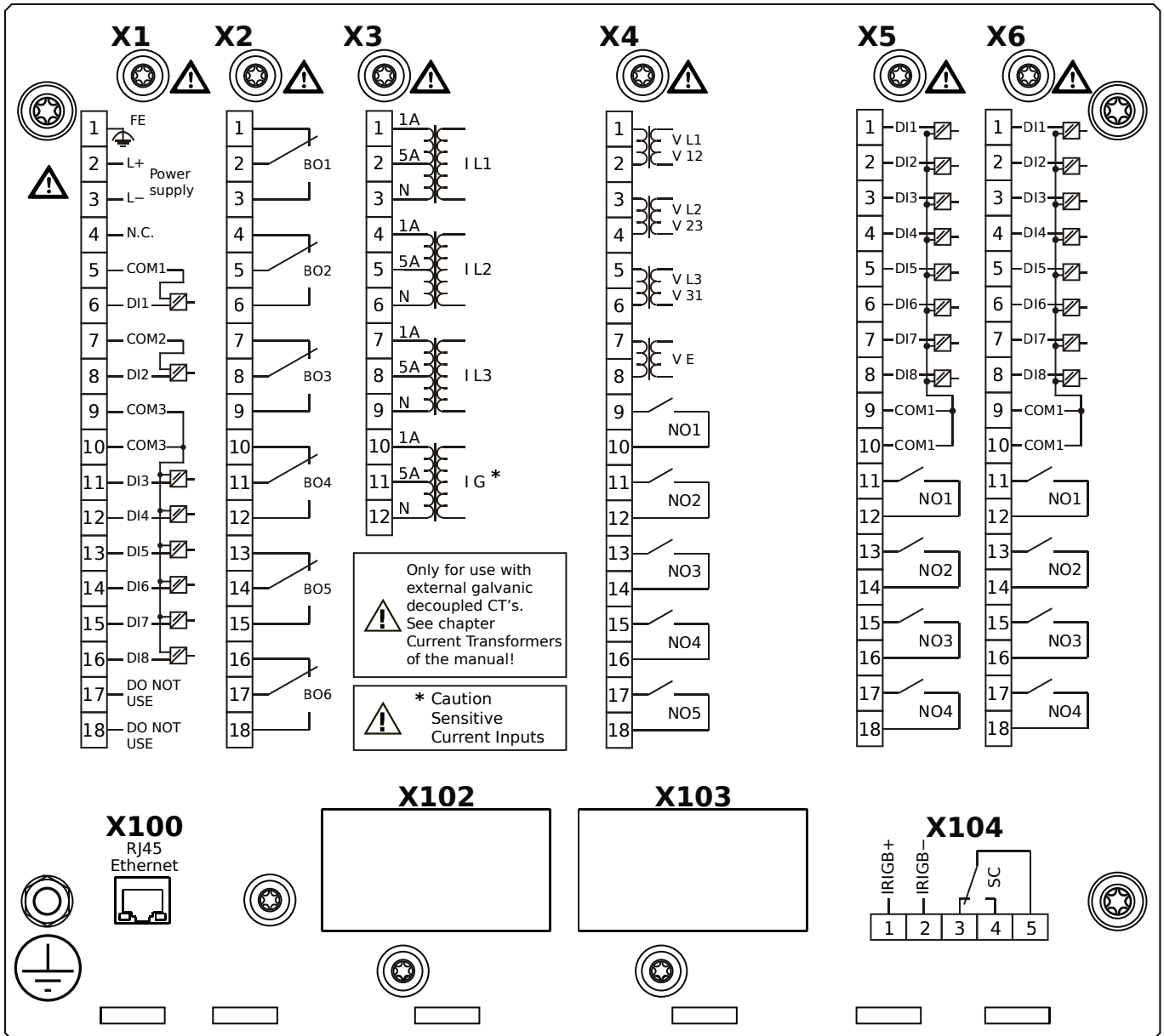

Housing B2, small display, door mounting

- X1** – DI8-X1: Wide-range power supply unit, incl. 2 non-grouped digital inputs and 6 grouped digital inputs
- X2** – OR6: Assembly Group with 6 Output Relays (Changeover / Form C)
- X3** – TIs: Standard phase current measuring card and sensitive ground current measuring
- X4** – TU-OR5: Voltage measuring (0 ... 300 VAC) assembly group with 5 additional Output Relays (NO / Form A)
- X5** – DI8-OR4: Assembly Group with 8 Digital Inputs and 4 Output Relays (NO / Form A)
- X6** – DI8-OR4: Assembly Group with 8 Digital Inputs and 4 Output Relays (NO / Form A)
- X100** – Modbus TCP / DNP3.0 TCP/UDP, Ethernet interface, 100 Mbit/s, RJ45 (BASE100-FX)
- X104** – IRIG-B00X, incl. System Contact (Supervision Contact)

MRA4-2E1ACB

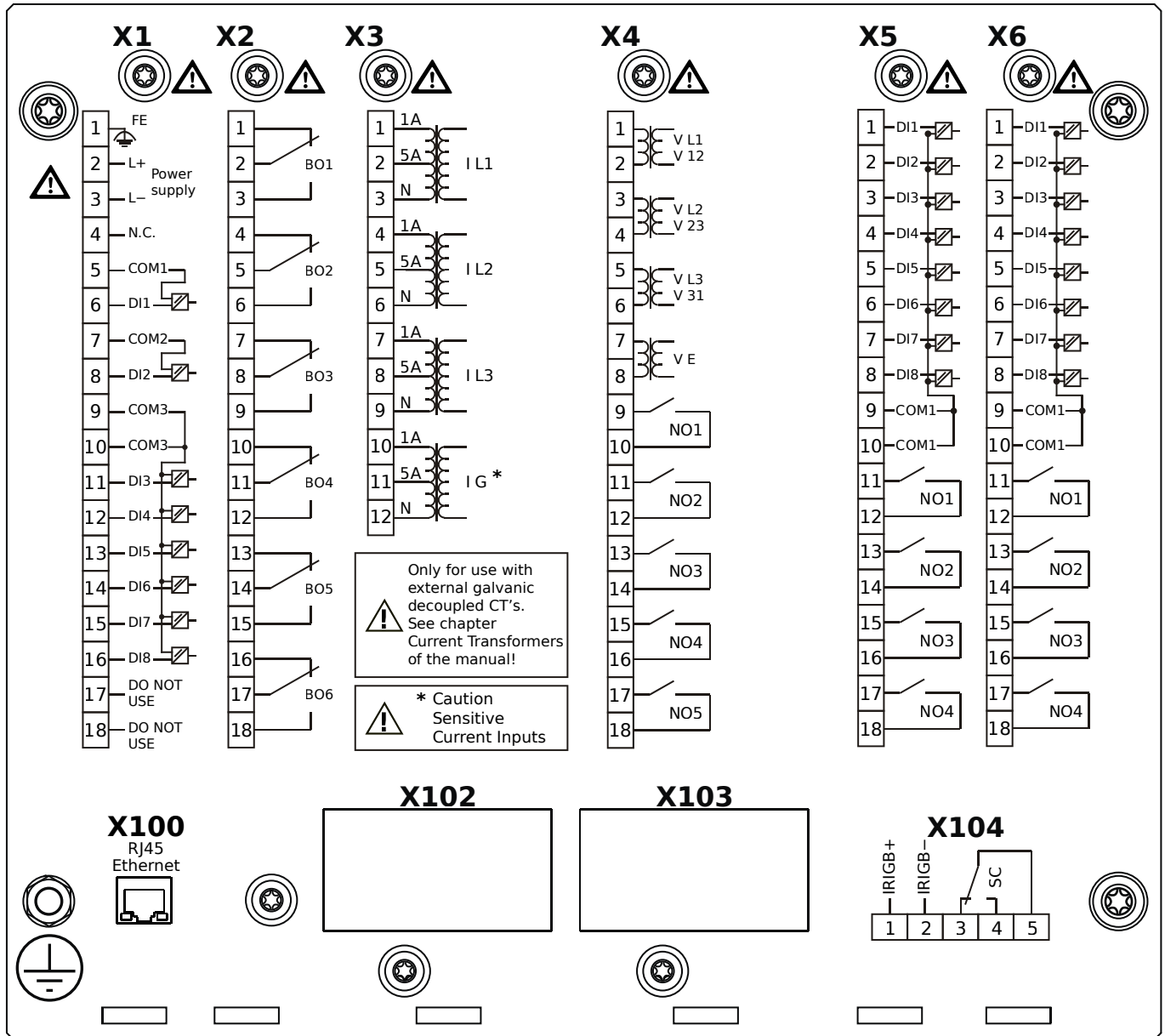

Housing B2, small display, door mounting

+ Conformal Coating (for installations in harsh environment)

- X1** – DI8-X1: Wide-range power supply unit, incl. 2 non-grouped digital inputs and 6 grouped digital inputs
- X2** – OR6: Assembly Group with 6 Output Relays (Changeover / Form C)
- X3** – TIs: Standard phase current measuring card and sensitive ground current measuring
- X4** – TU-OR5: Voltage measuring (0 ... 300 VAC) assembly group with 5 additional Output Relays (NO / Form A)
- X5** – DI8-OR4: Assembly Group with 8 Digital Inputs and 4 Output Relays (NO / Form A)
- X6** – DI8-OR4: Assembly Group with 8 Digital Inputs and 4 Output Relays (NO / Form A)
- X100** – Modbus TCP / DNP3.0 TCP/UDP, Ethernet interface, 100 Mbit/s, RJ45 (BASE100-FX)
- X104** – IRIG-B00X, incl. System Contact (Supervision Contact)

MRA4-2E1ADA

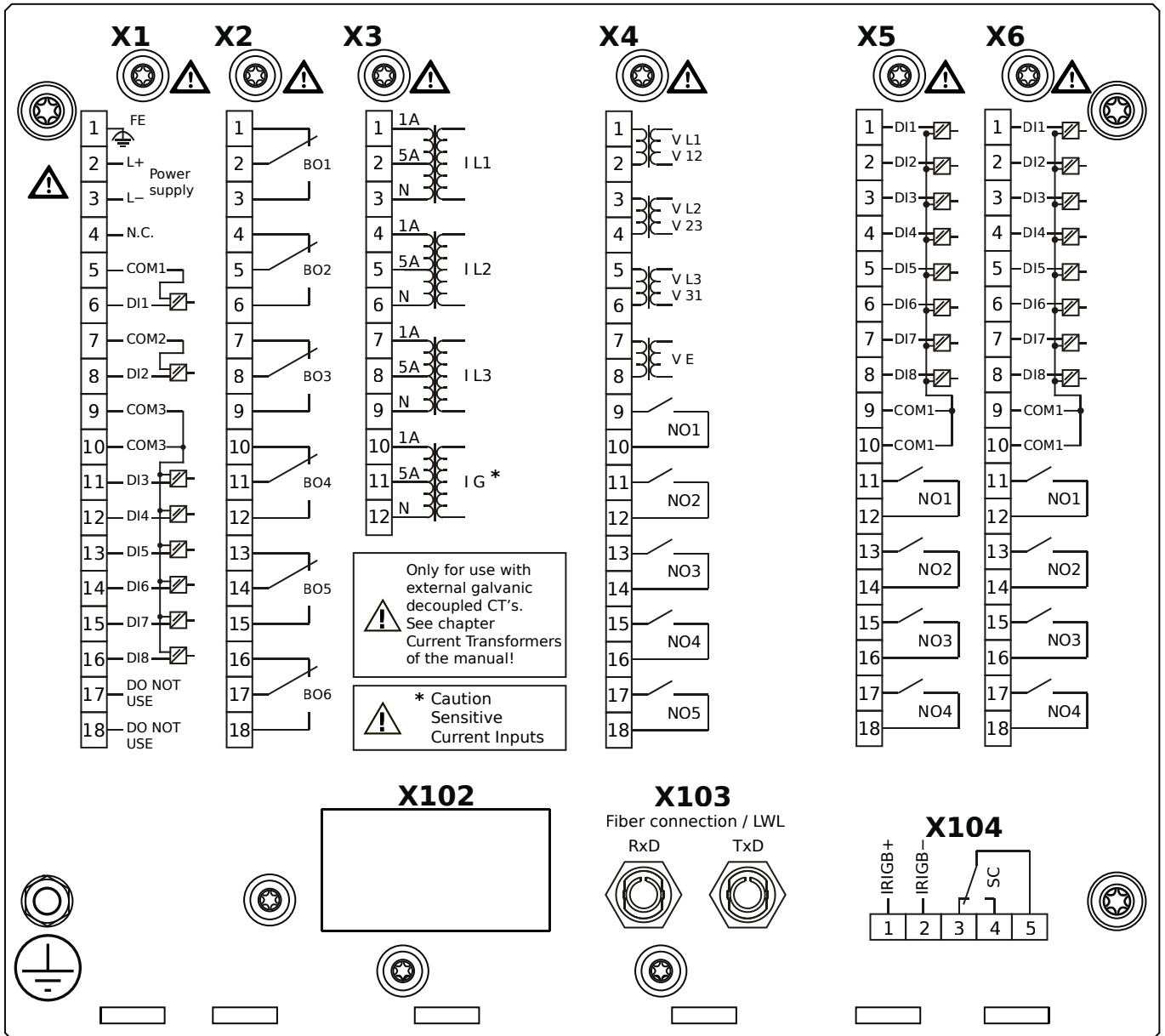

Housing B2, small display, door mounting

- X1** – DI8-X1: Wide-range power supply unit, incl. 2 non-grouped digital inputs and 6 grouped digital inputs
- X2** – OR6: Assembly Group with 6 Output Relays (Changeover / Form C)
- X3** – TIs: Standard phase current measuring card and sensitive ground current measuring
- X4** – TU-OR5: Voltage measuring (0 ... 300 VAC) assembly group with 5 additional Output Relays (NO / Form A)
- X5** – DI8-OR4: Assembly Group with 8 Digital Inputs and 4 Output Relays (NO / Form A)
- X6** – DI8-OR4: Assembly Group with 8 Digital Inputs and 4 Output Relays (NO / Form A)
- X103** – Profibus-DP, Fiber optics interface, ST Connector
- X104** – IRIG-B00X, incl. System Contact (Supervision Contact)

MRA4-2E1ADB

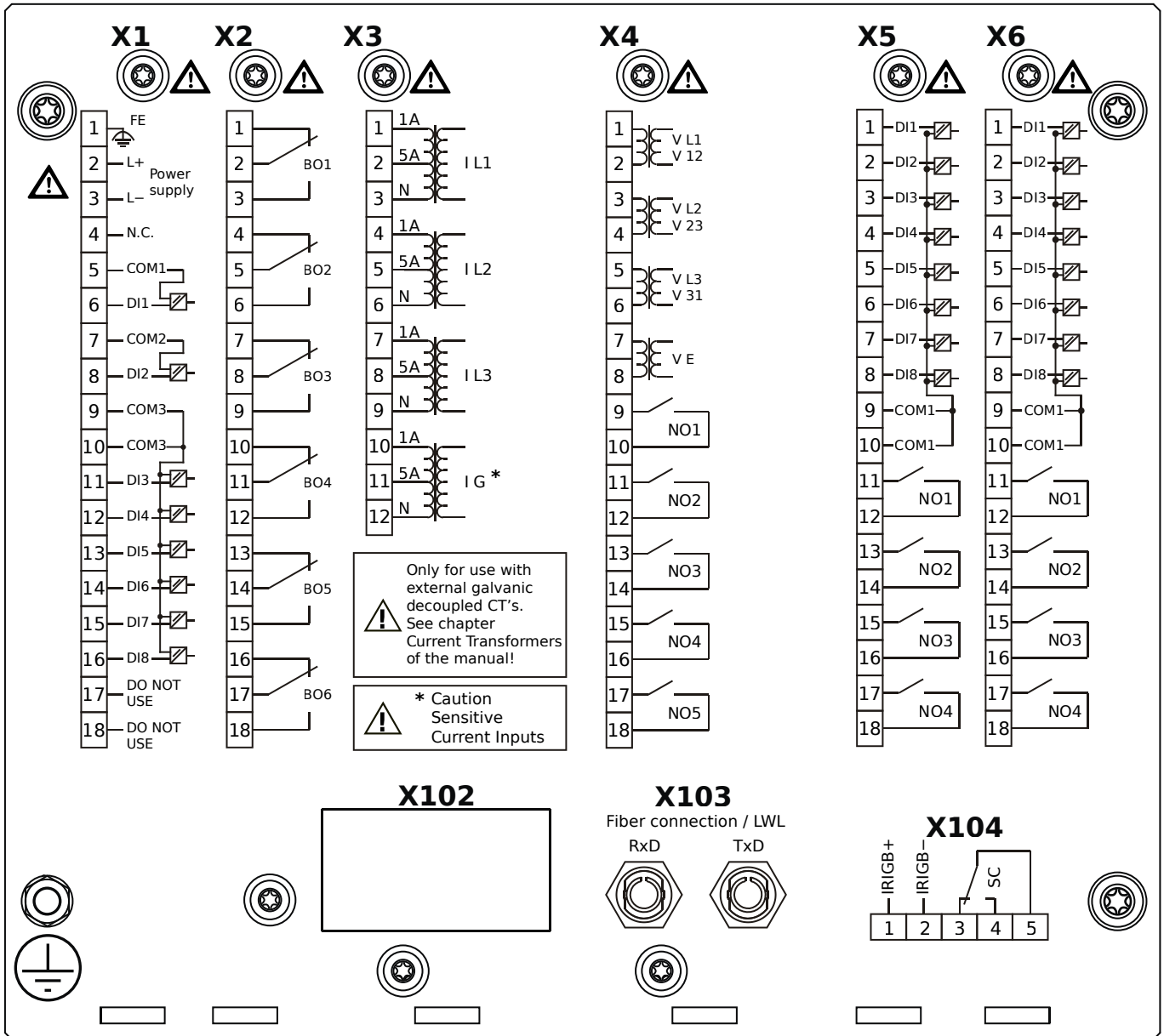

Housing B2, small display, door mounting

+ Conformal Coating (for installations in harsh environment)

- X1** – DI8-X1: Wide-range power supply unit, incl. 2 non-grouped digital inputs and 6 grouped digital inputs
- X2** – OR6: Assembly Group with 6 Output Relays (Changeover / Form C)
- X3** – TIs: Standard phase current measuring card and sensitive ground current measuring
- X4** – TU-OR5: Voltage measuring (0 ... 300 VAC) assembly group with 5 additional Output Relays (NO / Form A)
- X5** – DI8-OR4: Assembly Group with 8 Digital Inputs and 4 Output Relays (NO / Form A)
- X6** – DI8-OR4: Assembly Group with 8 Digital Inputs and 4 Output Relays (NO / Form A)
- X103** – Profibus-DP, Fiber optics interface, ST Connector
- X104** – IRIG-B00X, incl. System Contact (Supervision Contact)

MRA4-2E1AEA

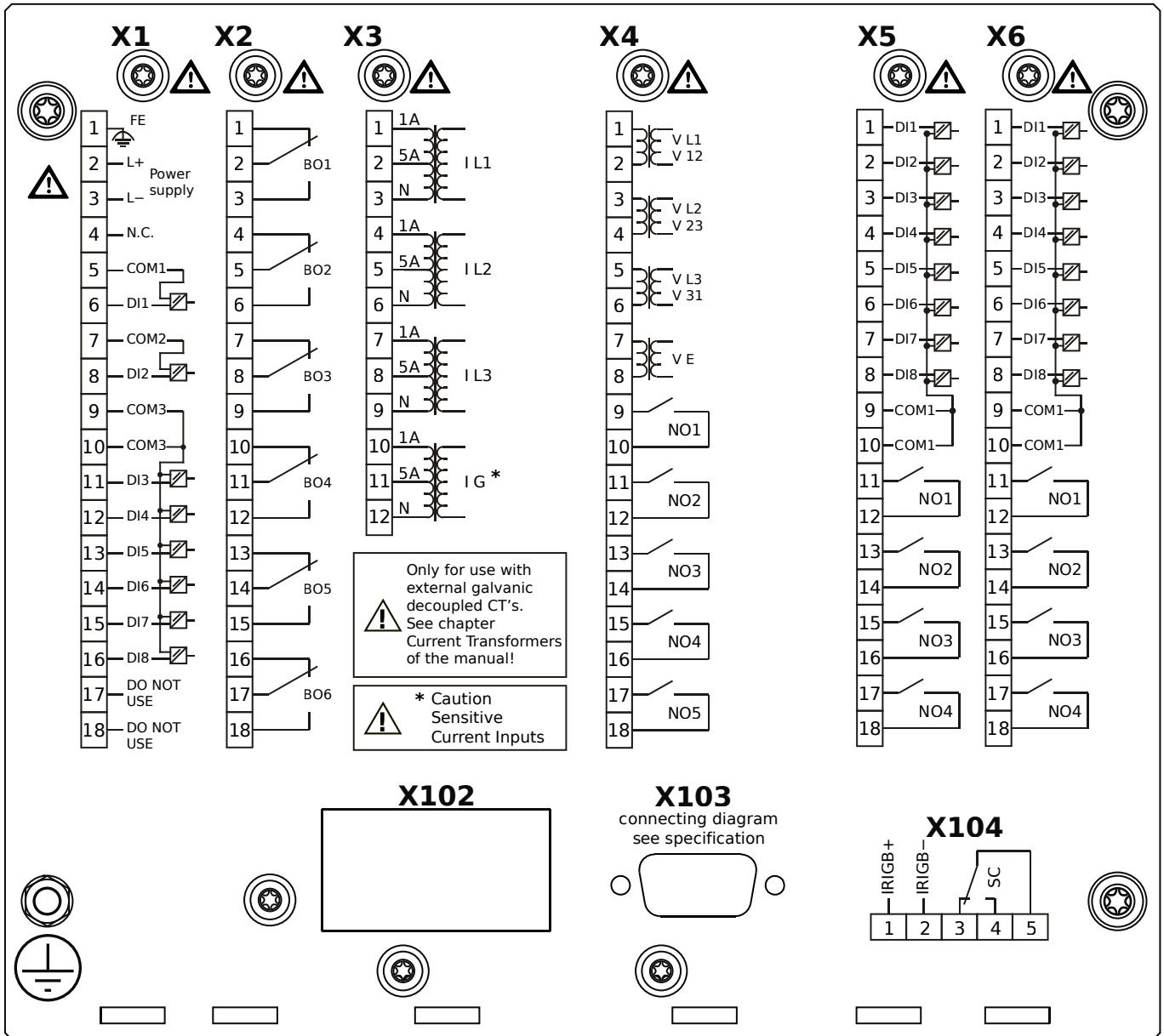

Housing B2, small display, door mounting

- X1** – DI8-X1: Wide-range power supply unit, incl. 2 non-grouped digital inputs and 6 grouped digital inputs
- X2** – OR6: Assembly Group with 6 Output Relays (Changeover / Form C)
- X3** – TIs: Standard phase current measuring card and sensitive ground current measuring
- X4** – TU-OR5: Voltage measuring (0 ... 300 VAC) assembly group with 5 additional Output Relays (NO / Form A)
- X5** – DI8-OR4: Assembly Group with 8 Digital Inputs and 4 Output Relays (NO / Form A)
- X6** – DI8-OR4: Assembly Group with 8 Digital Inputs and 4 Output Relays (NO / Form A)
- X103** – Profibus-DP, RS485, D-SUB
- X104** – IRIG-B00X, incl. System Contact (Supervision Contact)

MRA4-2E1AEB

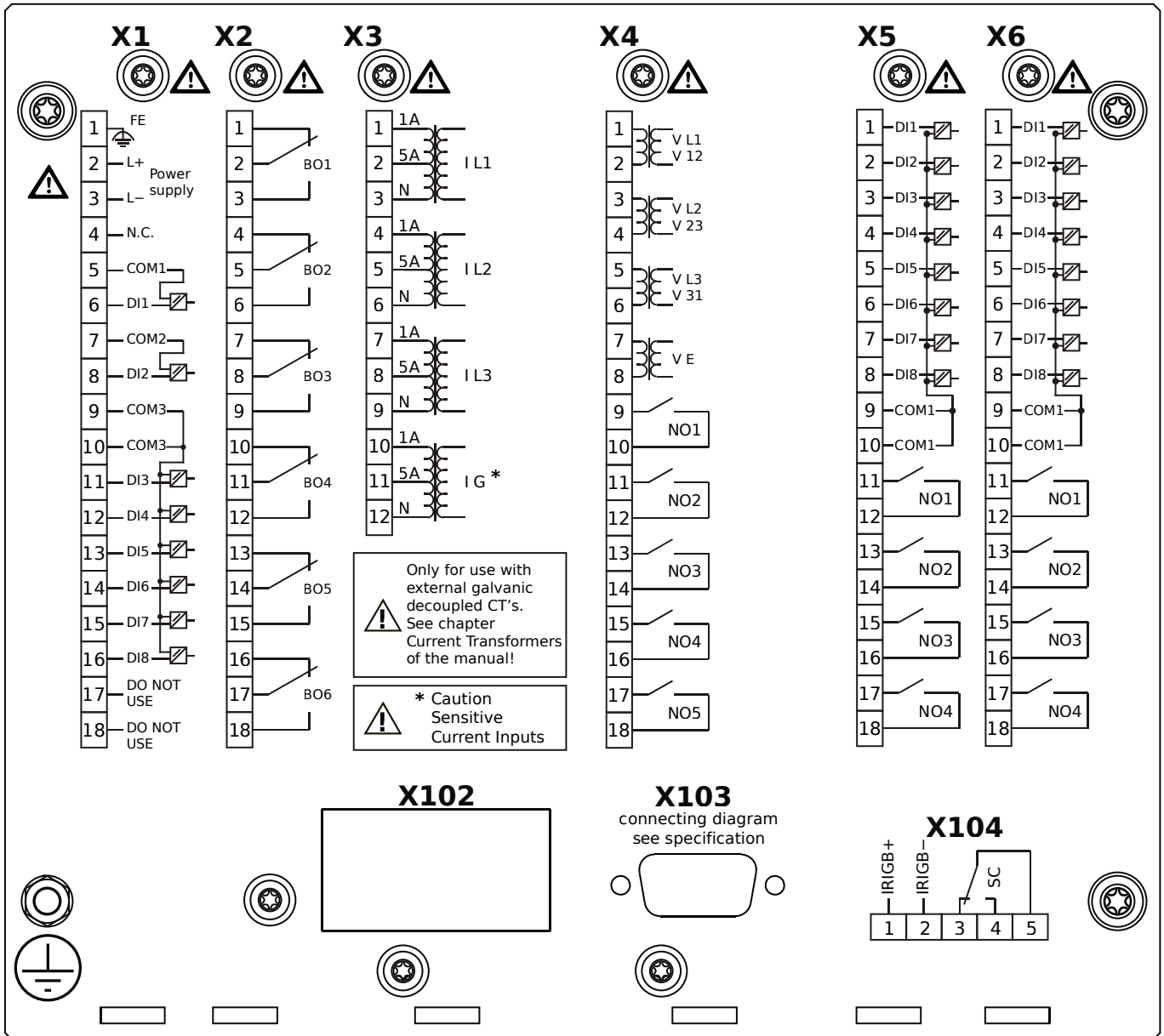

Housing B2, small display, door mounting

+ Conformal Coating (for installations in harsh environment)

- X1** – DI8-X1: Wide-range power supply unit, incl. 2 non-grouped digital inputs and 6 grouped digital inputs
- X2** – OR6: Assembly Group with 6 Output Relays (Changeover / Form C)
- X3** – TIs: Standard phase current measuring card and sensitive ground current measuring
- X4** – TU-OR5: Voltage measuring (0 ... 300 VAC) assembly group with 5 additional Output Relays (NO / Form A)
- X5** – DI8-OR4: Assembly Group with 8 Digital Inputs and 4 Output Relays (NO / Form A)
- X6** – DI8-OR4: Assembly Group with 8 Digital Inputs and 4 Output Relays (NO / Form A)
- X103** – Profibus-DP, RS485, D-SUB
- X104** – IRIG-B00X, incl. System Contact (Supervision Contact)

MRA4-2E1AFA

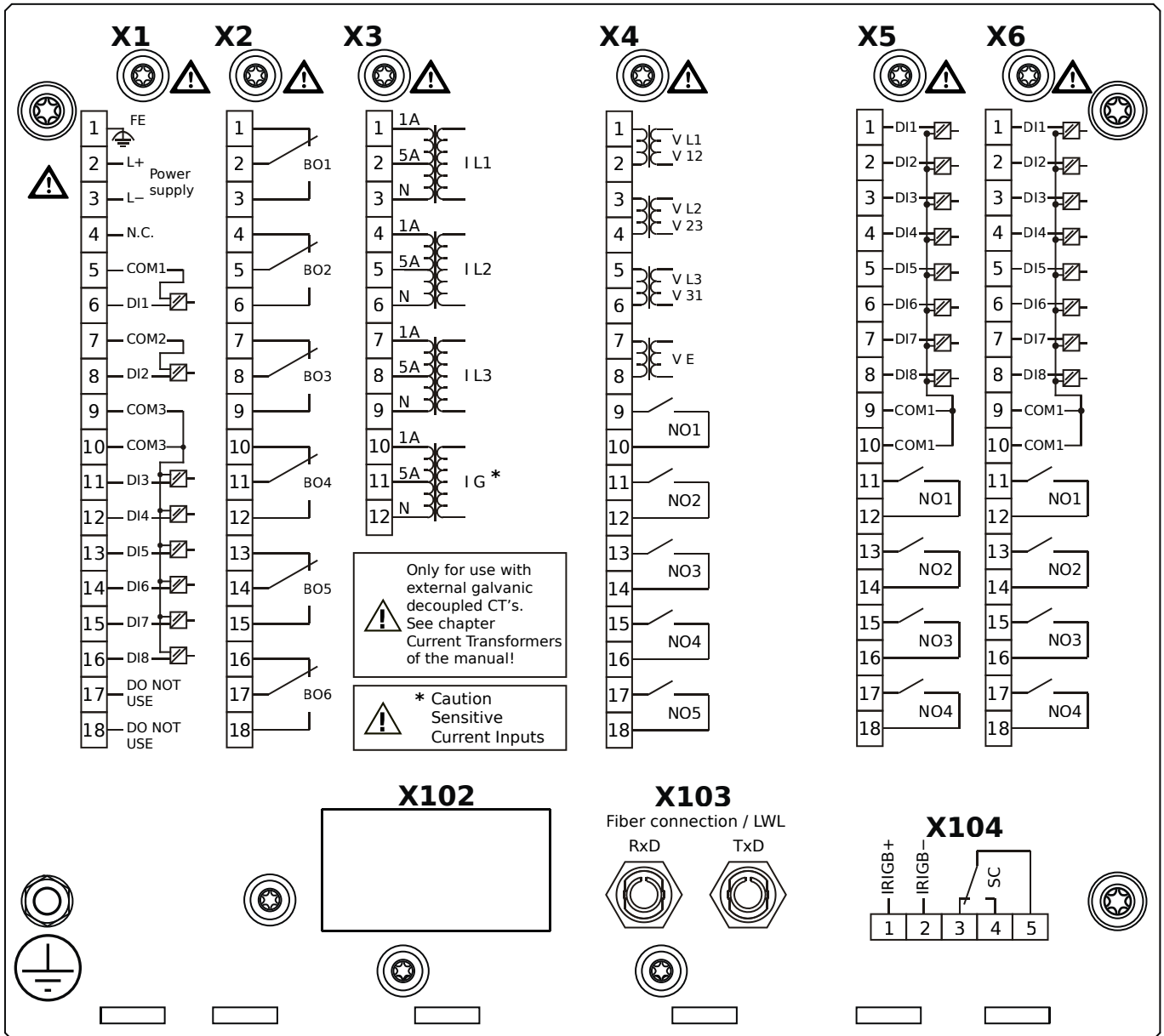

Housing B2, small display, door mounting

- X1** – DI8-X1: Wide-range power supply unit, incl. 2 non-grouped digital inputs and 6 grouped digital inputs
- X2** – OR6: Assembly Group with 6 Output Relays (Changeover / Form C)
- X3** – TIs: Standard phase current measuring card and sensitive ground current measuring
- X4** – TU-OR5: Voltage measuring (0 ... 300 VAC) assembly group with 5 additional Output Relays (NO / Form A)
- X5** – DI8-OR4: Assembly Group with 8 Digital Inputs and 4 Output Relays (NO / Form A)
- X6** – DI8-OR4: Assembly Group with 8 Digital Inputs and 4 Output Relays (NO / Form A)
- X103** – Modbus RTU / IEC 60870-5-103 / DNP3.0 RTU, Fiber optics interface, ST Connector
- X104** – IRIG-B00X, incl. System Contact (Supervision Contact)

MRA4-2E1AFB

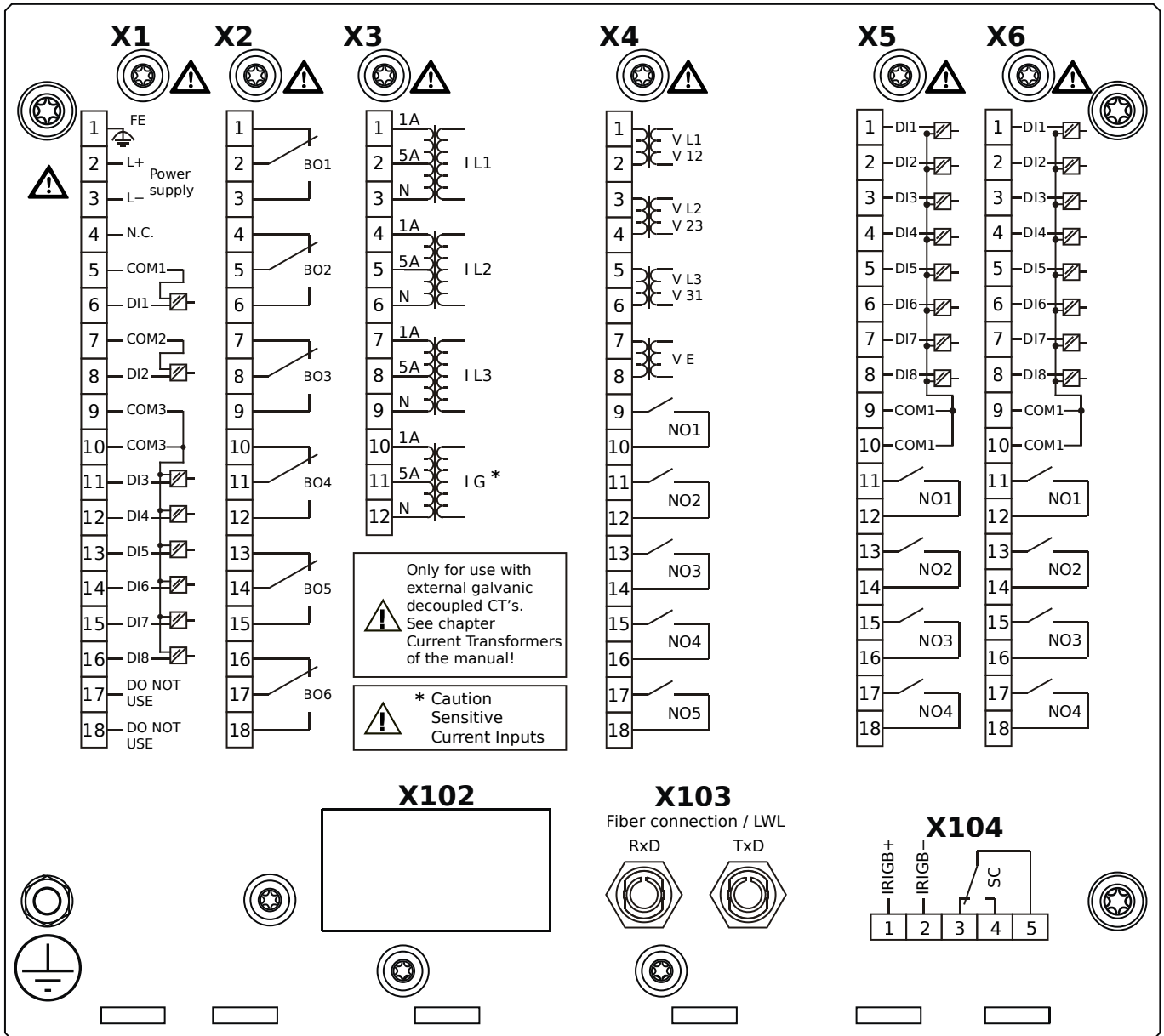

Housing B2, small display, door mounting

+ Conformal Coating (for installations in harsh environment)

- X1** – DI8-X1: Wide-range power supply unit, incl. 2 non-grouped digital inputs and 6 grouped digital inputs
- X2** – OR6: Assembly Group with 6 Output Relays (Changeover / Form C)
- X3** – TIs: Standard phase current measuring card and sensitive ground current measuring
- X4** – TU-OR5: Voltage measuring (0 ... 300 VAC) assembly group with 5 additional Output Relays (NO / Form A)
- X5** – DI8-OR4: Assembly Group with 8 Digital Inputs and 4 Output Relays (NO / Form A)
- X6** – DI8-OR4: Assembly Group with 8 Digital Inputs and 4 Output Relays (NO / Form A)
- X103** – Modbus RTU / IEC 60870-5-103 / DNP3.0 RTU, Fiber optics interface, ST Connector
- X104** – IRIG-B00X, incl. System Contact (Supervision Contact)

MRA4-2E1AGA

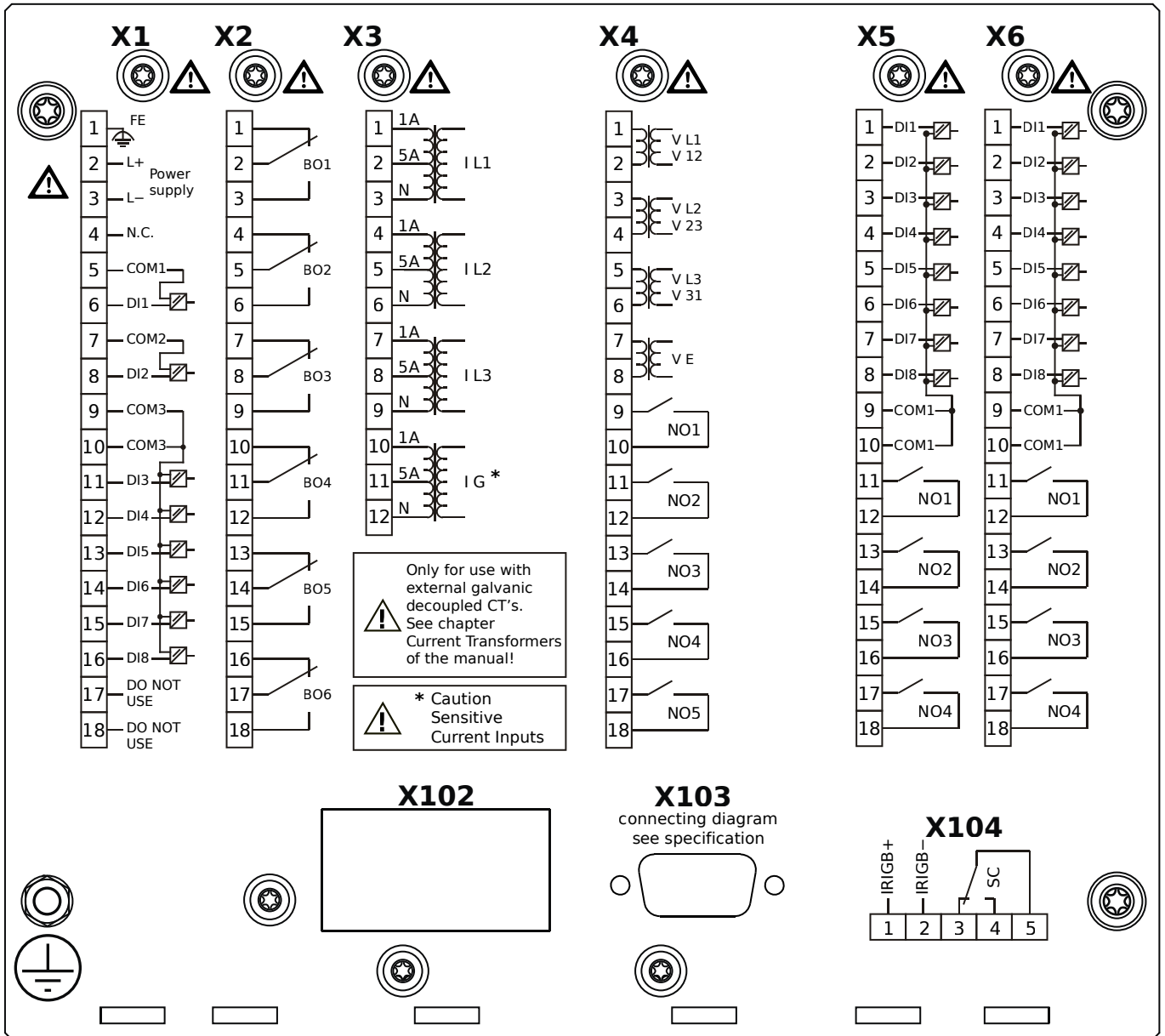

Housing B2, small display, door mounting

- X1** – DI8-X1: Wide-range power supply unit, incl. 2 non-grouped digital inputs and 6 grouped digital inputs
- X2** – OR6: Assembly Group with 6 Output Relays (Changeover / Form C)
- X3** – TIs: Standard phase current measuring card and sensitive ground current measuring
- X4** – TU-OR5: Voltage measuring (0 ... 300 VAC) assembly group with 5 additional Output Relays (NO / Form A)
- X5** – DI8-OR4: Assembly Group with 8 Digital Inputs and 4 Output Relays (NO / Form A)
- X6** – DI8-OR4: Assembly Group with 8 Digital Inputs and 4 Output Relays (NO / Form A)
- X103** – Modbus RTU / IEC 60870-5-103 / DNP3.0 RTU, RS485, D-SUB
- X104** – IRIG-B00X, incl. System Contact (Supervision Contact)

MRA4-2E1AGB

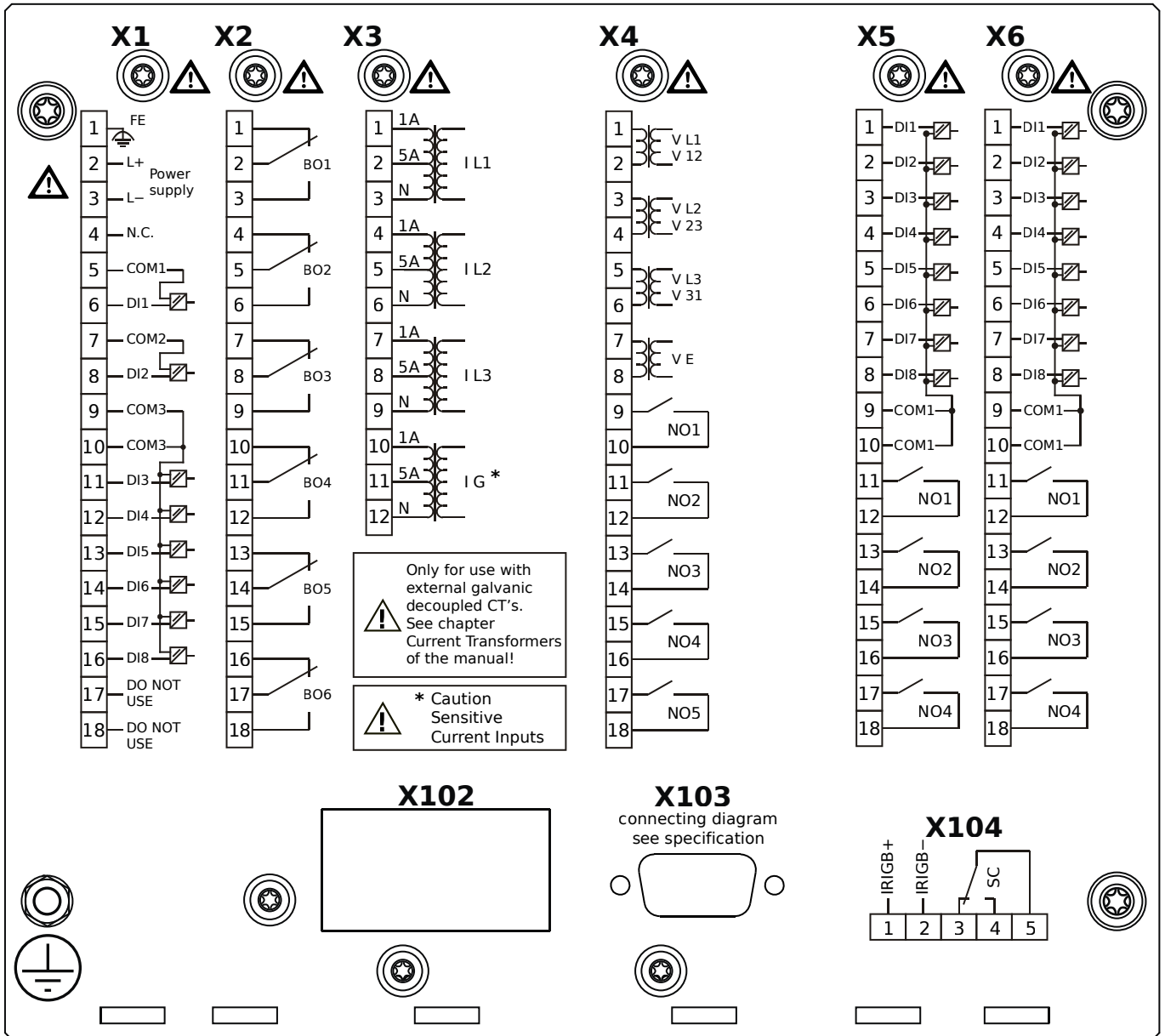

Housing B2, small display, door mounting

+ Conformal Coating (for installations in harsh environment)

- X1** – DI8-X1: Wide-range power supply unit, incl. 2 non-grouped digital inputs and 6 grouped digital inputs
- X2** – OR6: Assembly Group with 6 Output Relays (Changeover / Form C)
- X3** – TIs: Standard phase current measuring card and sensitive ground current measuring
- X4** – TU-OR5: Voltage measuring (0 ... 300 VAC) assembly group with 5 additional Output Relays (NO / Form A)
- X5** – DI8-OR4: Assembly Group with 8 Digital Inputs and 4 Output Relays (NO / Form A)
- X6** – DI8-OR4: Assembly Group with 8 Digital Inputs and 4 Output Relays (NO / Form A)
- X103** – Modbus RTU / IEC 60870-5-103 / DNP3.0 RTU, RS485, D-SUB
- X104** – IRIG-B00X, incl. System Contact (Supervision Contact)

MRA4-2E1AHA

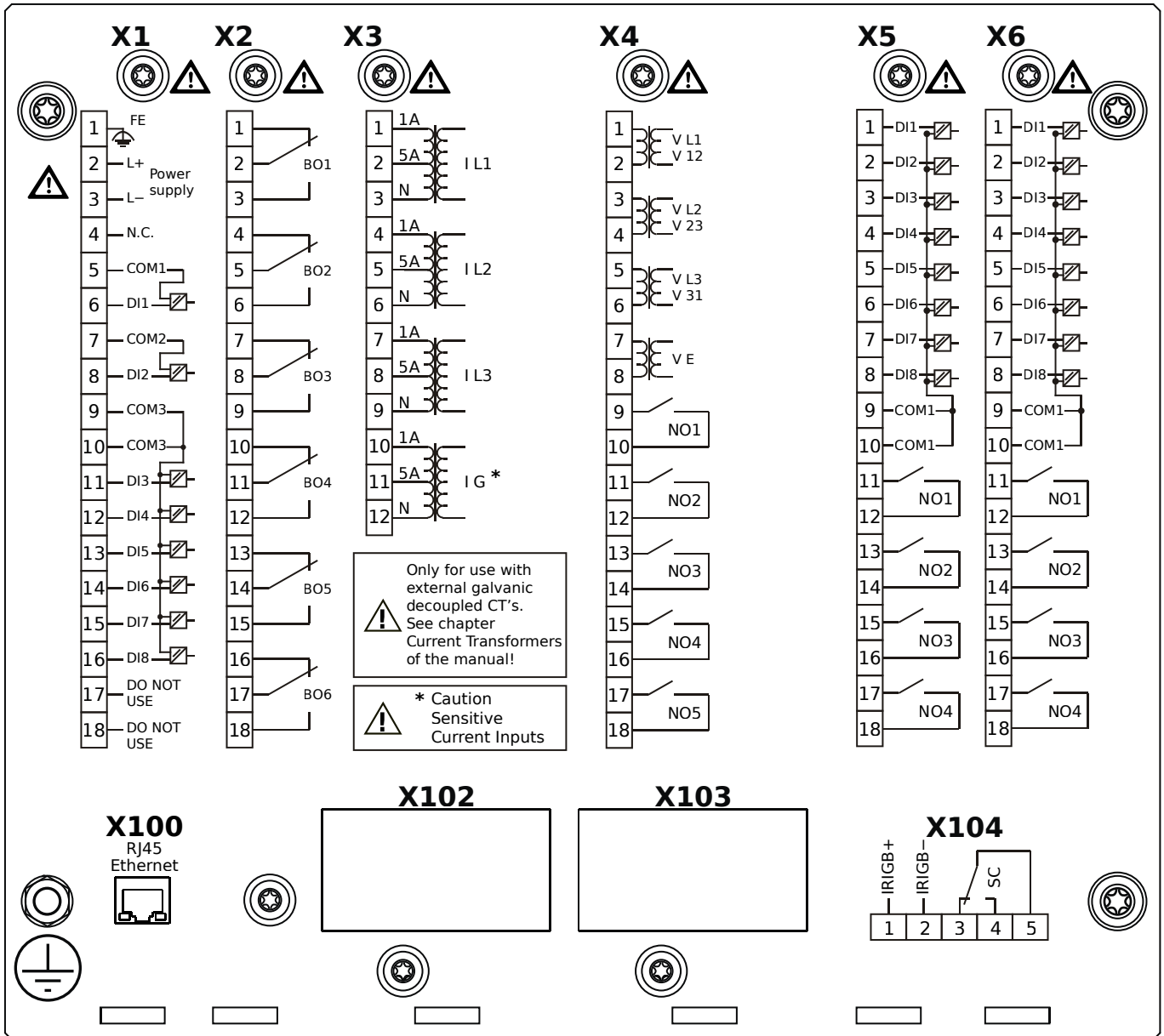

Housing B2, small display, door mounting

- X1** – DI8-X1: Wide-range power supply unit, incl. 2 non-grouped digital inputs and 6 grouped digital inputs
- X2** – OR6: Assembly Group with 6 Output Relays (Changeover / Form C)
- X3** – TIs: Standard phase current measuring card and sensitive ground current measuring
- X4** – TU-OR5: Voltage measuring (0 ... 300 VAC) assembly group with 5 additional Output Relays (NO / Form A)
- X5** – DI8-OR4: Assembly Group with 8 Digital Inputs and 4 Output Relays (NO / Form A)
- X6** – DI8-OR4: Assembly Group with 8 Digital Inputs and 4 Output Relays (NO / Form A)
- X100** – IEC 61850 / Modbus TCP / DNP3.0 TCP/UDP, Ethernet interface, 100 Mbit/s, RJ45 (BASE100-FX)
- X104** – IRIG-B00X, incl. System Contact (Supervision Contact)

MRA4-2E1AHB

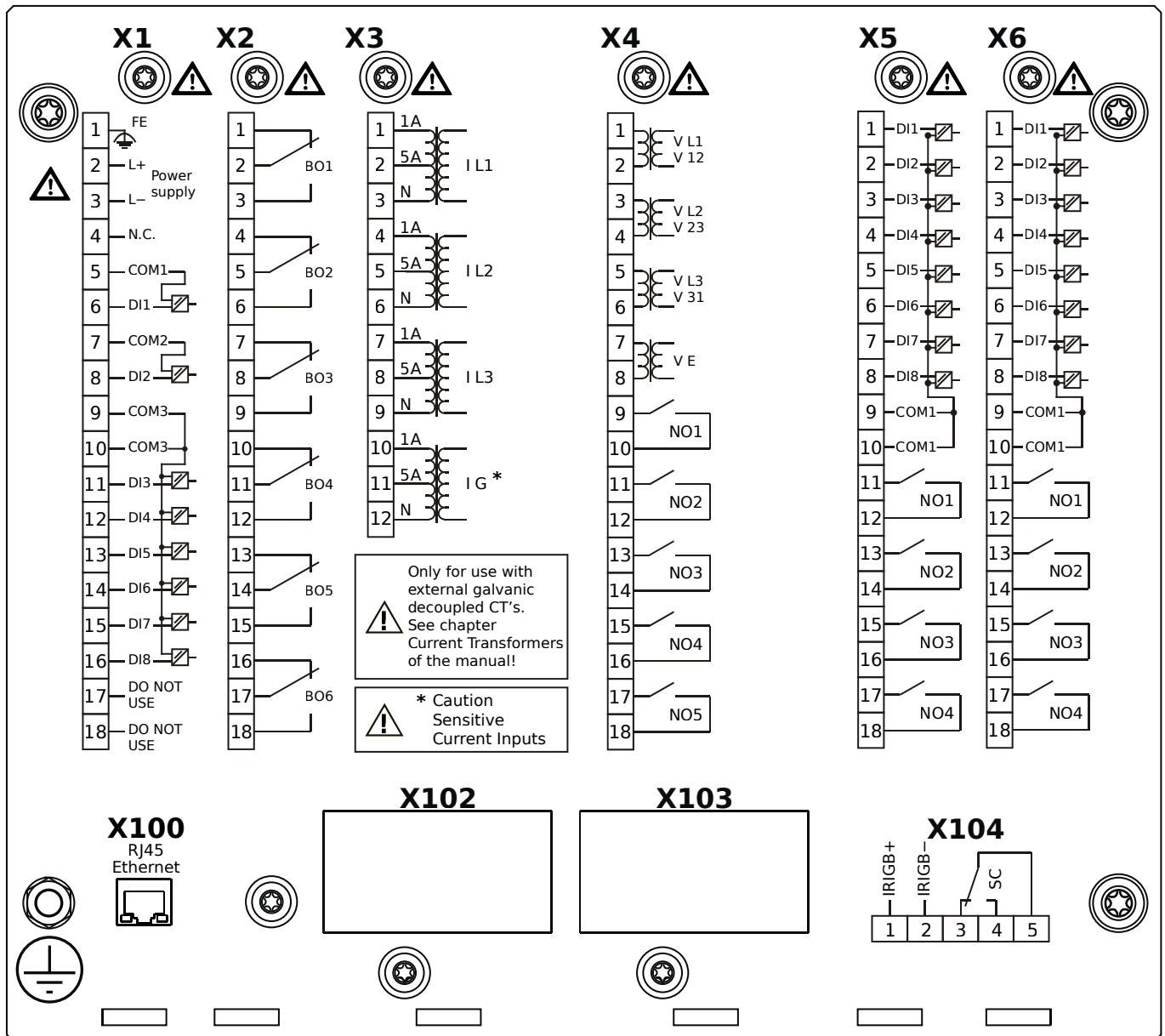

Housing B2, small display, door mounting

+ Conformal Coating (for installations in harsh environment)

- X1** – DI8-X1: Wide-range power supply unit, incl. 2 non-grouped digital inputs and 6 grouped digital inputs
- X2** – OR6: Assembly Group with 6 Output Relays (Changeover / Form C)
- X3** – TIs: Standard phase current measuring card and sensitive ground current measuring
- X4** – TU-OR5: Voltage measuring (0 ... 300 VAC) assembly group with 5 additional Output Relays (NO / Form A)
- X5** – DI8-OR4: Assembly Group with 8 Digital Inputs and 4 Output Relays (NO / Form A)
- X6** – DI8-OR4: Assembly Group with 8 Digital Inputs and 4 Output Relays (NO / Form A)
- X100** – IEC 61850 / Modbus TCP / DNP3.0 TCP/UDP, Ethernet interface, 100 Mbit/s, RJ45 (BASE100-FX)
- X104** – IRIG-B00X, incl. System Contact (Supervision Contact)

MRA4-2E1AIA

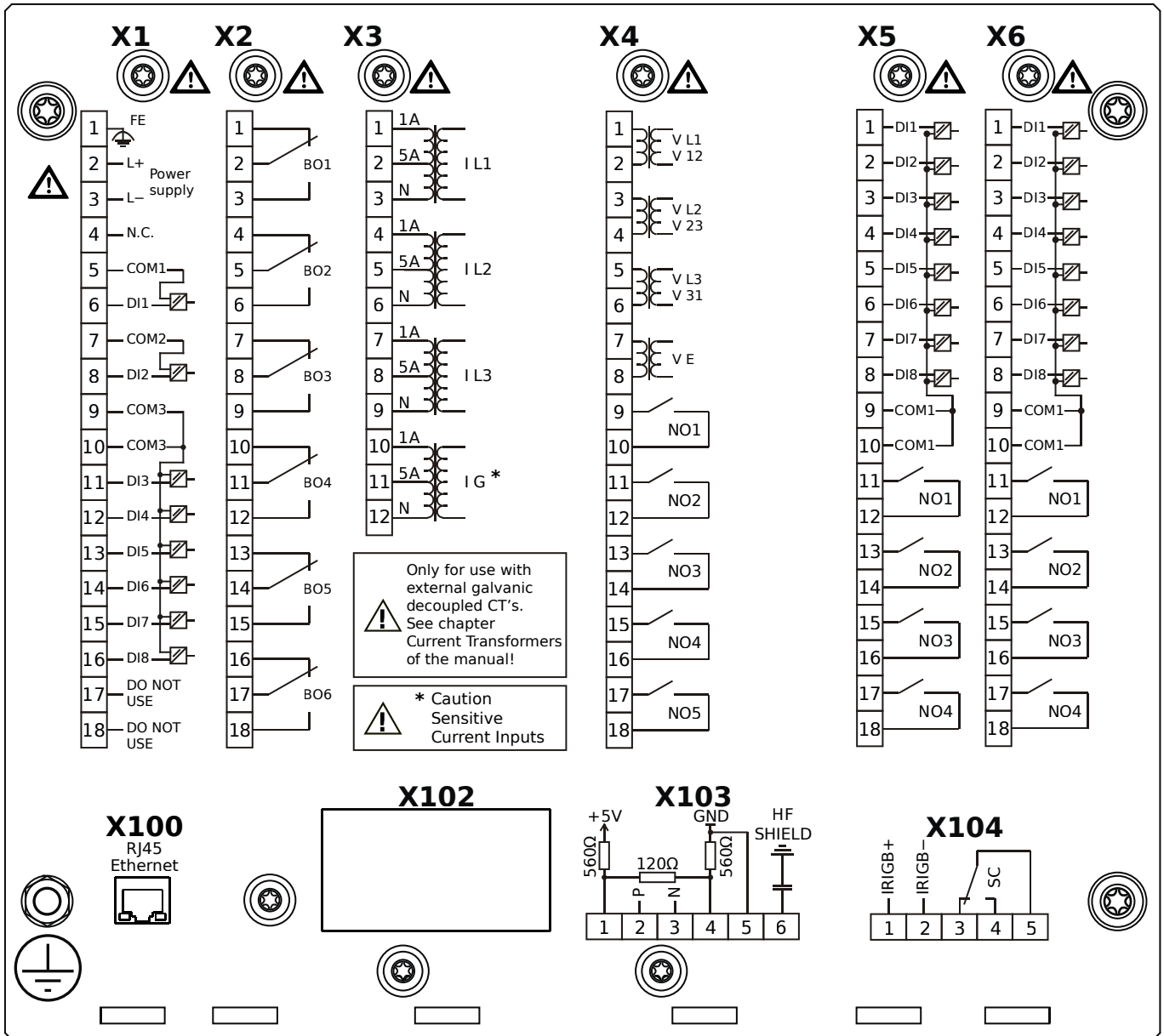

Housing B2, small display, door mounting

- X1** – DI8-X1: Wide-range power supply unit, incl. 2 non-grouped digital inputs and 6 grouped digital inputs
- X2** – OR6: Assembly Group with 6 Output Relays (Changeover / Form C)
- X3** – TIs: Standard phase current measuring card and sensitive ground current measuring
- X4** – TU-OR5: Voltage measuring (0 ... 300 VAC) assembly group with 5 additional Output Relays (NO / Form A)
- X5** – DI8-OR4: Assembly Group with 8 Digital Inputs and 4 Output Relays (NO / Form A)
- X6** – DI8-OR4: Assembly Group with 8 Digital Inputs and 4 Output Relays (NO / Form A)
- X100** – Modbus TCP / DNP3.0 TCP/UDP, Ethernet interface, 100 Mbit/s, RJ45 (BASE100-FX)
- X103** – IEC 60870-5-103 / Modbus RTU / DNP3.0 RTU, RS485, Terminals
- X104** – IRIG-B00X, incl. System Contact (Supervision Contact)

MRA4-2E1AIB

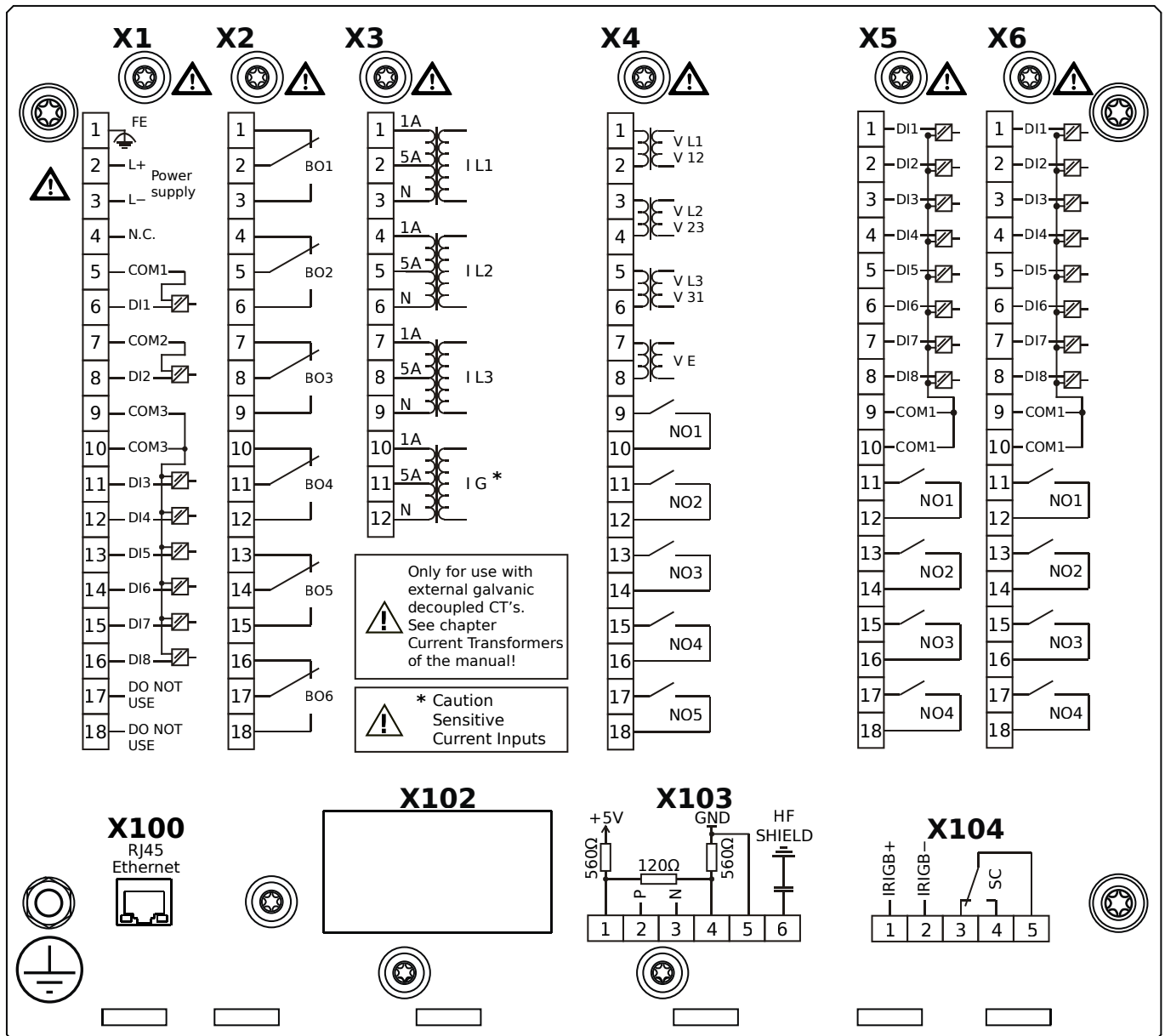

Housing B2, small display, door mounting

+ Conformal Coating (for installations in harsh environment)

- X1** – DI8-X1: Wide-range power supply unit, incl. 2 non-grouped digital inputs and 6 grouped digital inputs
- X2** – OR6: Assembly Group with 6 Output Relays (Changeover / Form C)
- X3** – TIs: Standard phase current measuring card and sensitive ground current measuring
- X4** – TU-OR5: Voltage measuring (0 ... 300 VAC) assembly group with 5 additional Output Relays (NO / Form A)
- X5** – DI8-OR4: Assembly Group with 8 Digital Inputs and 4 Output Relays (NO / Form A)
- X6** – DI8-OR4: Assembly Group with 8 Digital Inputs and 4 Output Relays (NO / Form A)
- X100** – Modbus TCP / DNP3.0 TCP/UDP, Ethernet interface, 100 Mbit/s, RJ45 (BASE100-FX)
- X103** – IEC 60870-5-103 / Modbus RTU / DNP3.0 RTU, RS485, Terminals
- X104** – IRIG-B00X, incl. System Contact (Supervision Contact)

MRA4-2E1AKA

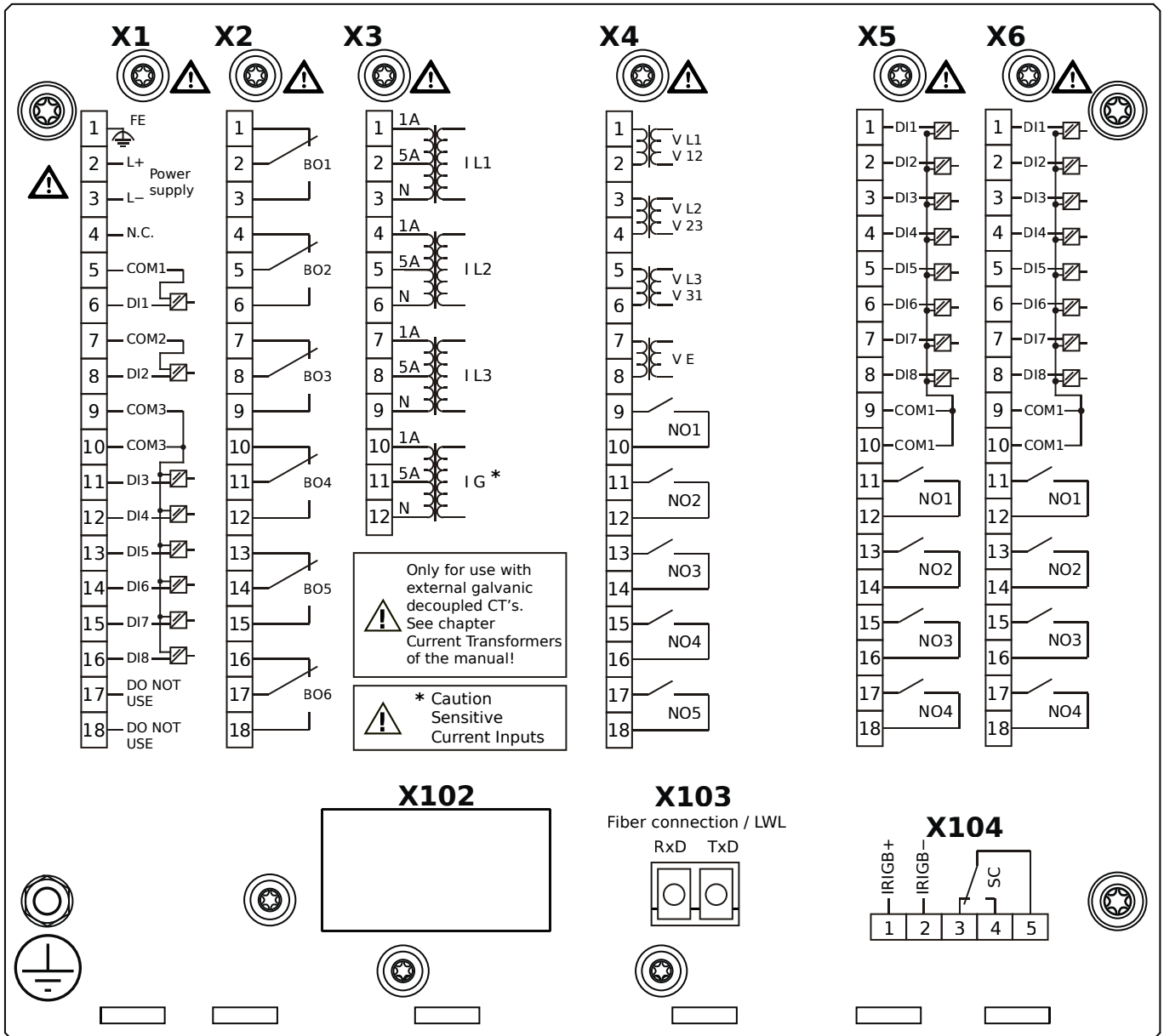

Housing B2, small display, door mounting

- X1** – DI8-X1: Wide-range power supply unit, incl. 2 non-grouped digital inputs and 6 grouped digital inputs
- X2** – OR6: Assembly Group with 6 Output Relays (Changeover / Form C)
- X3** – TIs: Standard phase current measuring card and sensitive ground current measuring
- X4** – TU-OR5: Voltage measuring (0 ... 300 VAC) assembly group with 5 additional Output Relays (NO / Form A)
- X5** – DI8-OR4: Assembly Group with 8 Digital Inputs and 4 Output Relays (NO / Form A)
- X6** – DI8-OR4: Assembly Group with 8 Digital Inputs and 4 Output Relays (NO / Form A)
- X103** – IEC 61850 / Modbus TCP / DNP3.0 TCP/UDP, Fiber optics interface, LC Connector
- X104** – IRIG-B00X, incl. System Contact (Supervision Contact)

MRA4-2E1AKB

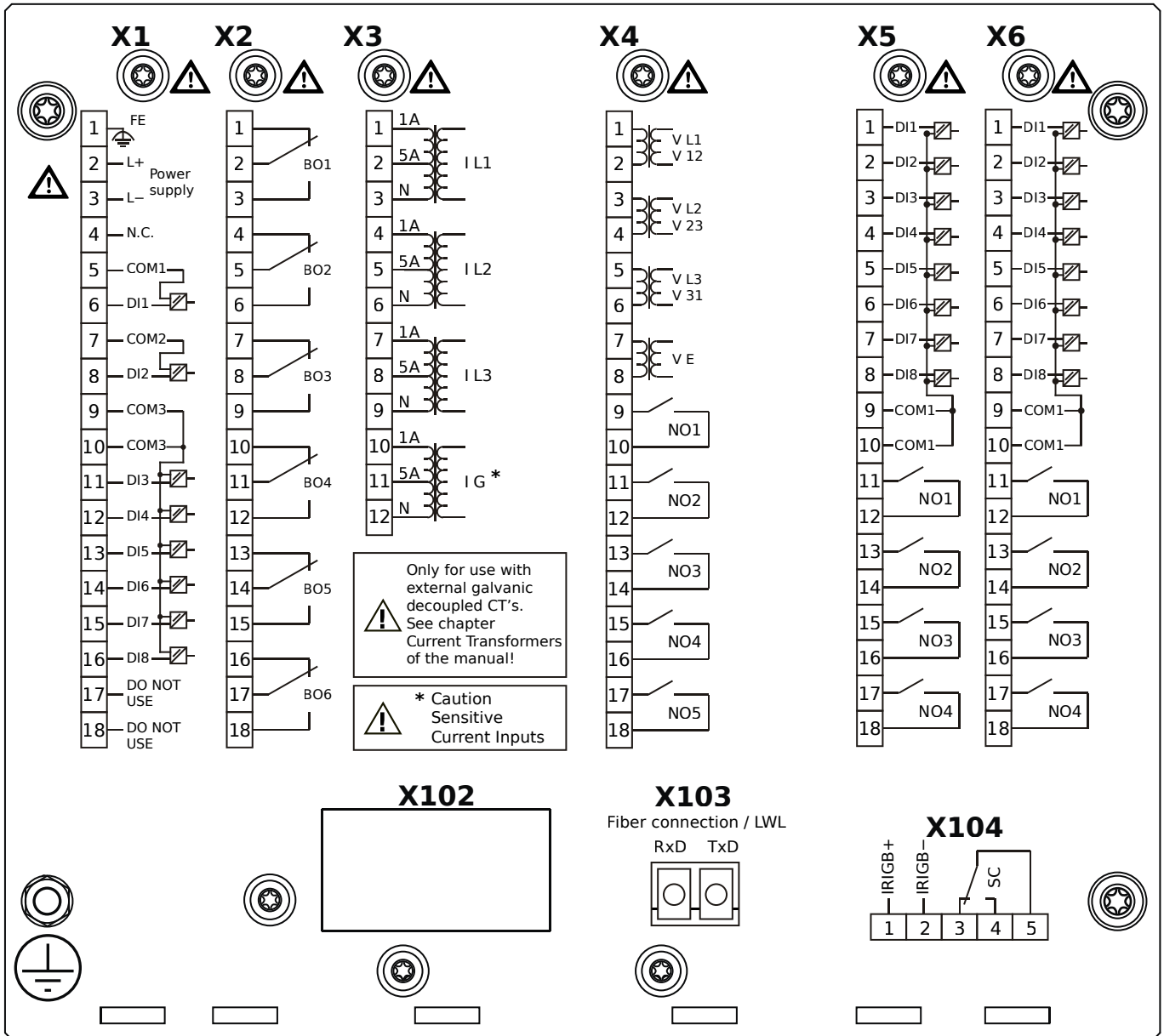

Housing B2, small display, door mounting

+ Conformal Coating (for installations in harsh environment)

- X1** – DI8-X1: Wide-range power supply unit, incl. 2 non-grouped digital inputs and 6 grouped digital inputs
- X2** – OR6: Assembly Group with 6 Output Relays (Changeover / Form C)
- X3** – TIs: Standard phase current measuring card and sensitive ground current measuring
- X4** – TU-OR5: Voltage measuring (0 ... 300 VAC) assembly group with 5 additional Output Relays (NO / Form A)
- X5** – DI8-OR4: Assembly Group with 8 Digital Inputs and 4 Output Relays (NO / Form A)
- X6** – DI8-OR4: Assembly Group with 8 Digital Inputs and 4 Output Relays (NO / Form A)
- X103** – IEC 61850 / Modbus TCP / DNP3.0 TCP/UDP, Fiber optics interface, LC Connector
- X104** – IRIG-B00X, incl. System Contact (Supervision Contact)

MRA4-2E1ALA

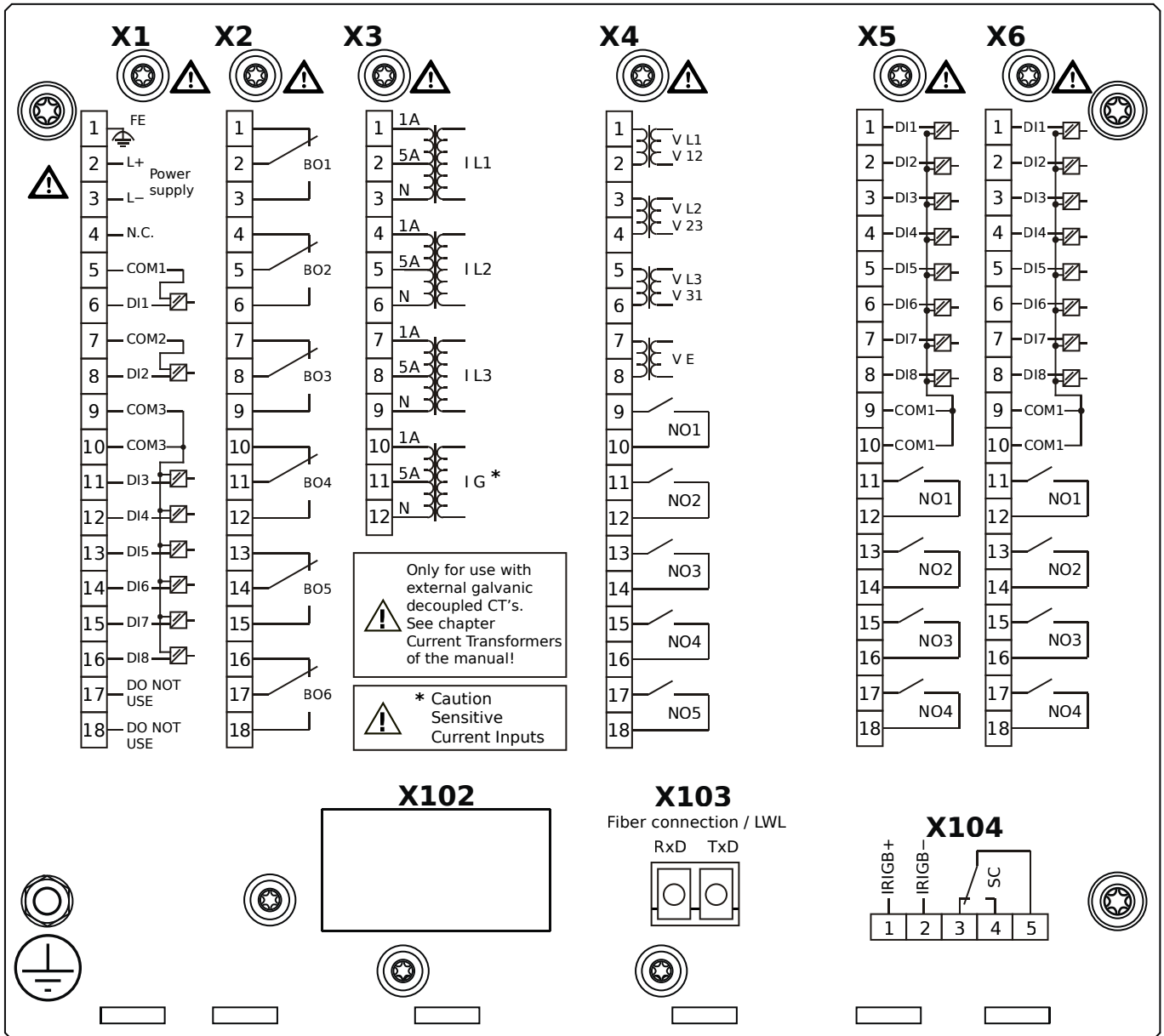

Housing B2, small display, door mounting

- X1** – DI8-X1: Wide-range power supply unit, incl. 2 non-grouped digital inputs and 6 grouped digital inputs
- X2** – OR6: Assembly Group with 6 Output Relays (Changeover / Form C)
- X3** – TIs: Standard phase current measuring card and sensitive ground current measuring
- X4** – TU-OR5: Voltage measuring (0 ... 300 VAC) assembly group with 5 additional Output Relays (NO / Form A)
- X5** – DI8-OR4: Assembly Group with 8 Digital Inputs and 4 Output Relays (NO / Form A)
- X6** – DI8-OR4: Assembly Group with 8 Digital Inputs and 4 Output Relays (NO / Form A)
- X103** – Modbus TCP / DNP3.0 TCP/UDP, Fiber optics interface, LC Connector
- X104** – IRIG-B00X, incl. System Contact (Supervision Contact)

MRA4-2E1ALB

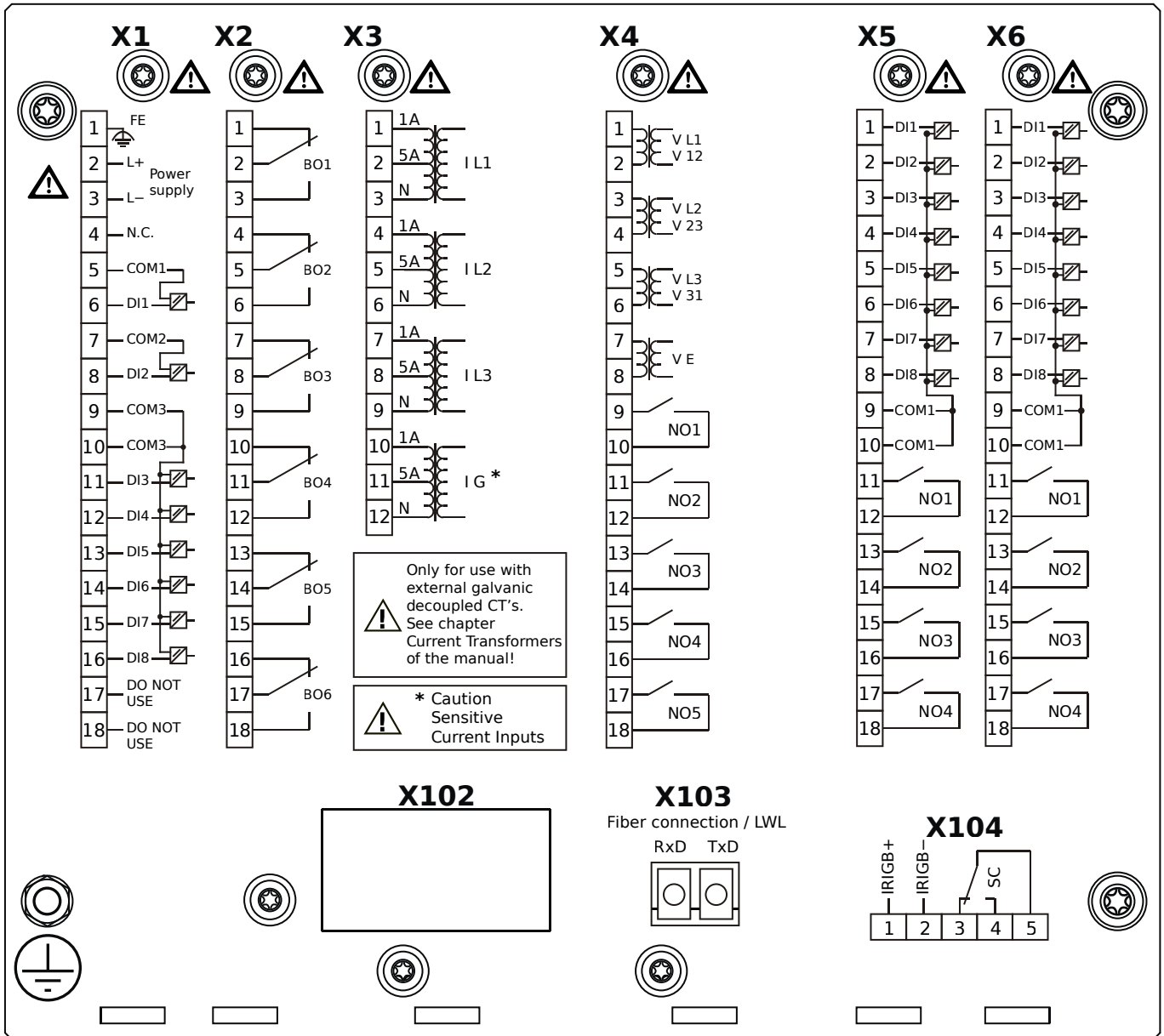

Housing B2, small display, door mounting

+ Conformal Coating (for installations in harsh environment)

- X1** – DI8-X1: Wide-range power supply unit, incl. 2 non-grouped digital inputs and 6 grouped digital inputs
- X2** – OR6: Assembly Group with 6 Output Relays (Changeover / Form C)
- X3** – TIs: Standard phase current measuring card and sensitive ground current measuring
- X4** – TU-OR5: Voltage measuring (0 ... 300 VAC) assembly group with 5 additional Output Relays (NO / Form A)
- X5** – DI8-OR4: Assembly Group with 8 Digital Inputs and 4 Output Relays (NO / Form A)
- X6** – DI8-OR4: Assembly Group with 8 Digital Inputs and 4 Output Relays (NO / Form A)
- X103** – Modbus TCP / DNP3.0 TCP/UDP, Fiber optics interface, LC Connector
- X104** – IRIG-B00X, incl. System Contact (Supervision Contact)

MRA4-2E1ATA

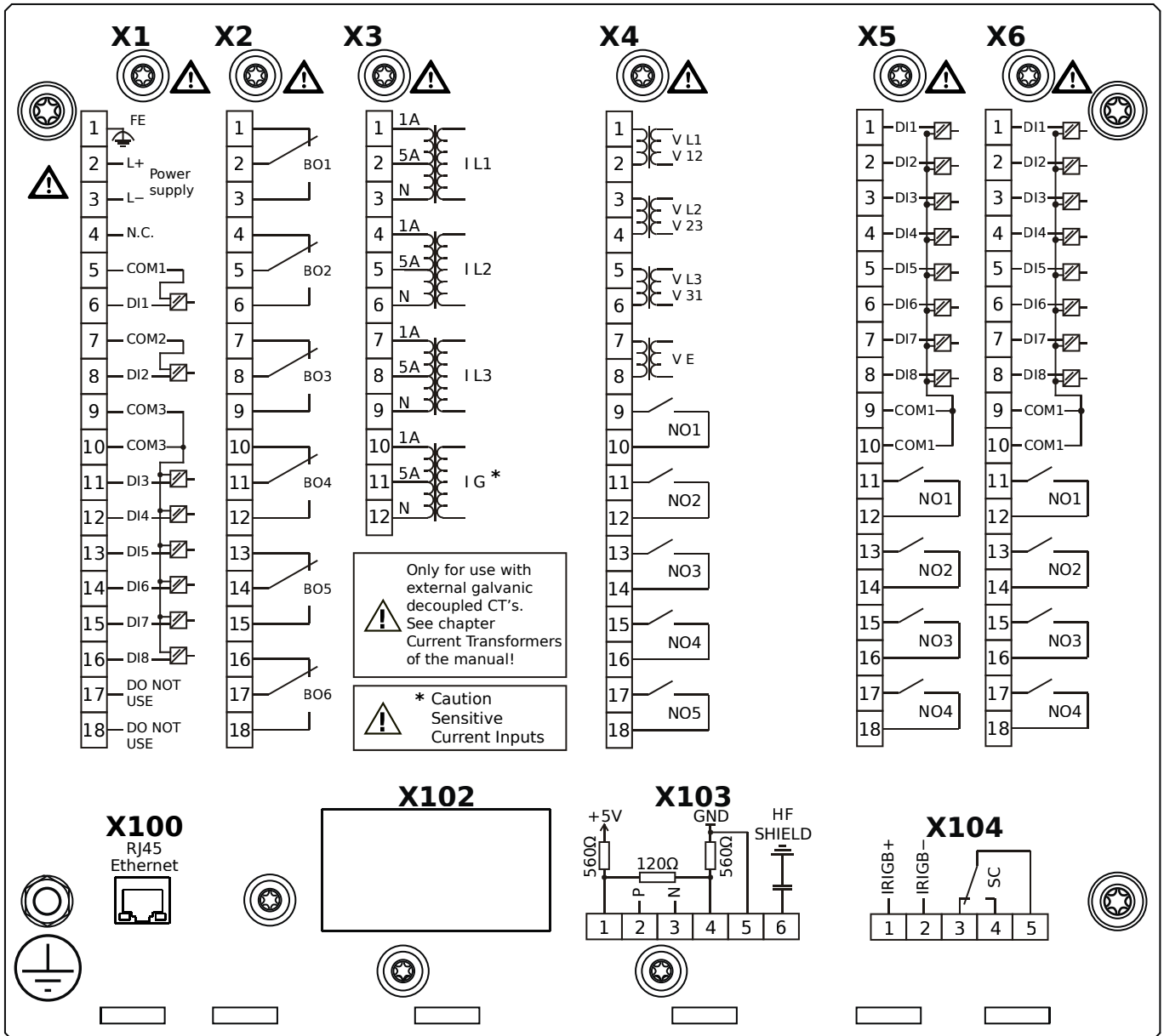

Housing B2, small display, door mounting

- X1** – DI8-X1: Wide-range power supply unit, incl. 2 non-grouped digital inputs and 6 grouped digital inputs
- X2** – OR6: Assembly Group with 6 Output Relays (Changeover / Form C)
- X3** – TIs: Standard phase current measuring card and sensitive ground current measuring
- X4** – TU-OR5: Voltage measuring (0 ... 300 VAC) assembly group with 5 additional Output Relays (NO / Form A)
- X5** – DI8-OR4: Assembly Group with 8 Digital Inputs and 4 Output Relays (NO / Form A)
- X6** – DI8-OR4: Assembly Group with 8 Digital Inputs and 4 Output Relays (NO / Form A)
- X100** – IEC 61850 / Modbus TCP / DNP3.0 TCP/UDP, Ethernet interface, 100 Mbit/s, RJ45 (BASE100-FX)
- X103** – IEC 60870-5-103 / Modbus RTU / DNP3.0 RTU, RS485, Terminals
- X104** – IRIG-B00X, incl. System Contact (Supervision Contact)

MRA4-2E1ATB

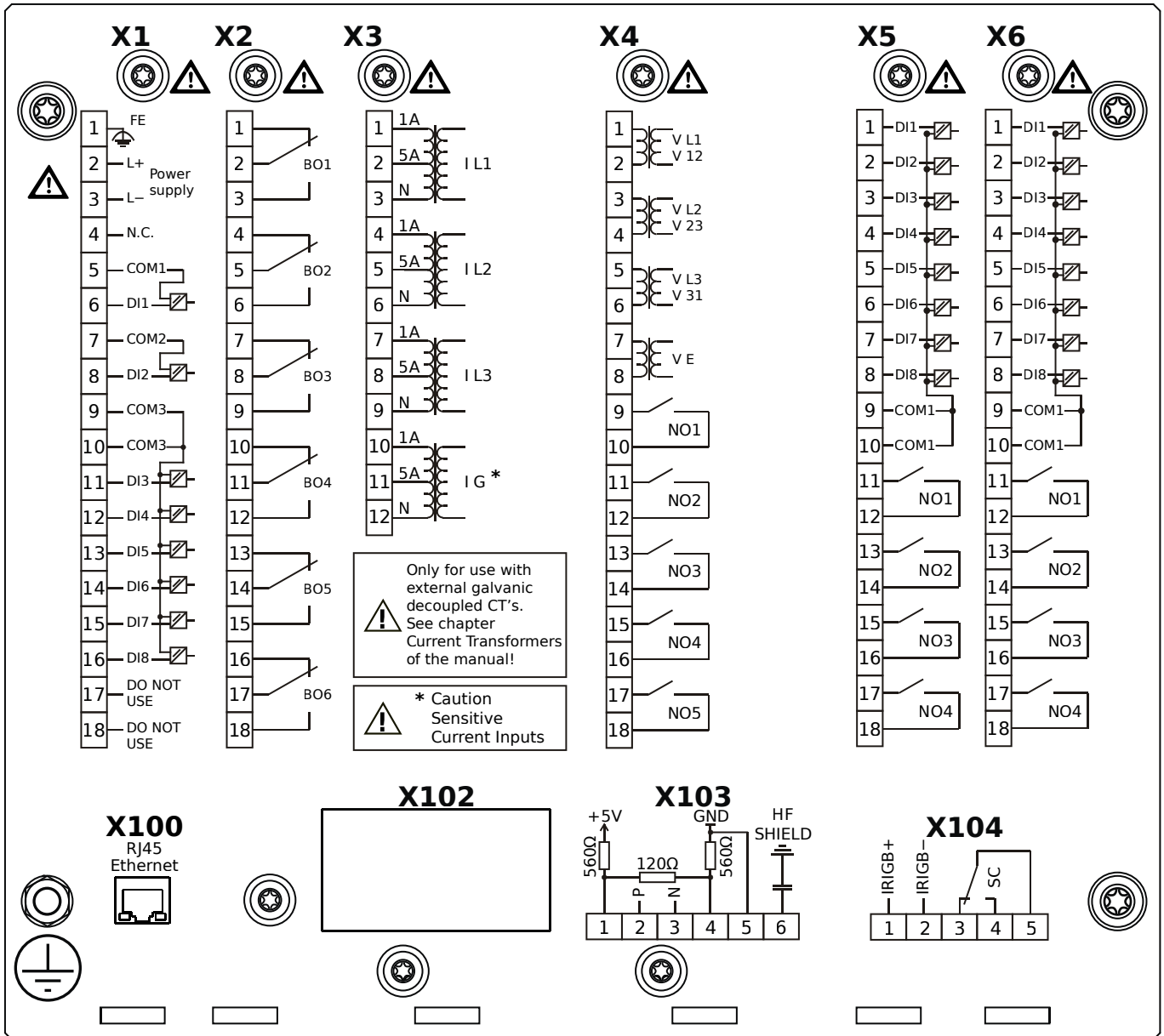

Housing B2, small display, door mounting

+ Conformal Coating (for installations in harsh environment)

- X1** – DI8-X1: Wide-range power supply unit, incl. 2 non-grouped digital inputs and 6 grouped digital inputs
- X2** – OR6: Assembly Group with 6 Output Relays (Changeover / Form C)
- X3** – TIs: Standard phase current measuring card and sensitive ground current measuring
- X4** – TU-OR5: Voltage measuring (0 ... 300 VAC) assembly group with 5 additional Output Relays (NO / Form A)
- X5** – DI8-OR4: Assembly Group with 8 Digital Inputs and 4 Output Relays (NO / Form A)
- X6** – DI8-OR4: Assembly Group with 8 Digital Inputs and 4 Output Relays (NO / Form A)
- X100** – IEC 61850 / Modbus TCP / DNP3.0 TCP/UDP, Ethernet interface, 100 Mbit/s, RJ45 (BASE100-FX)
- X103** – IEC 60870-5-103 / Modbus RTU / DNP3.0 RTU, RS485, Terminals
- X104** – IRIG-B00X, incl. System Contact (Supervision Contact)

MRA4-2E1BAA

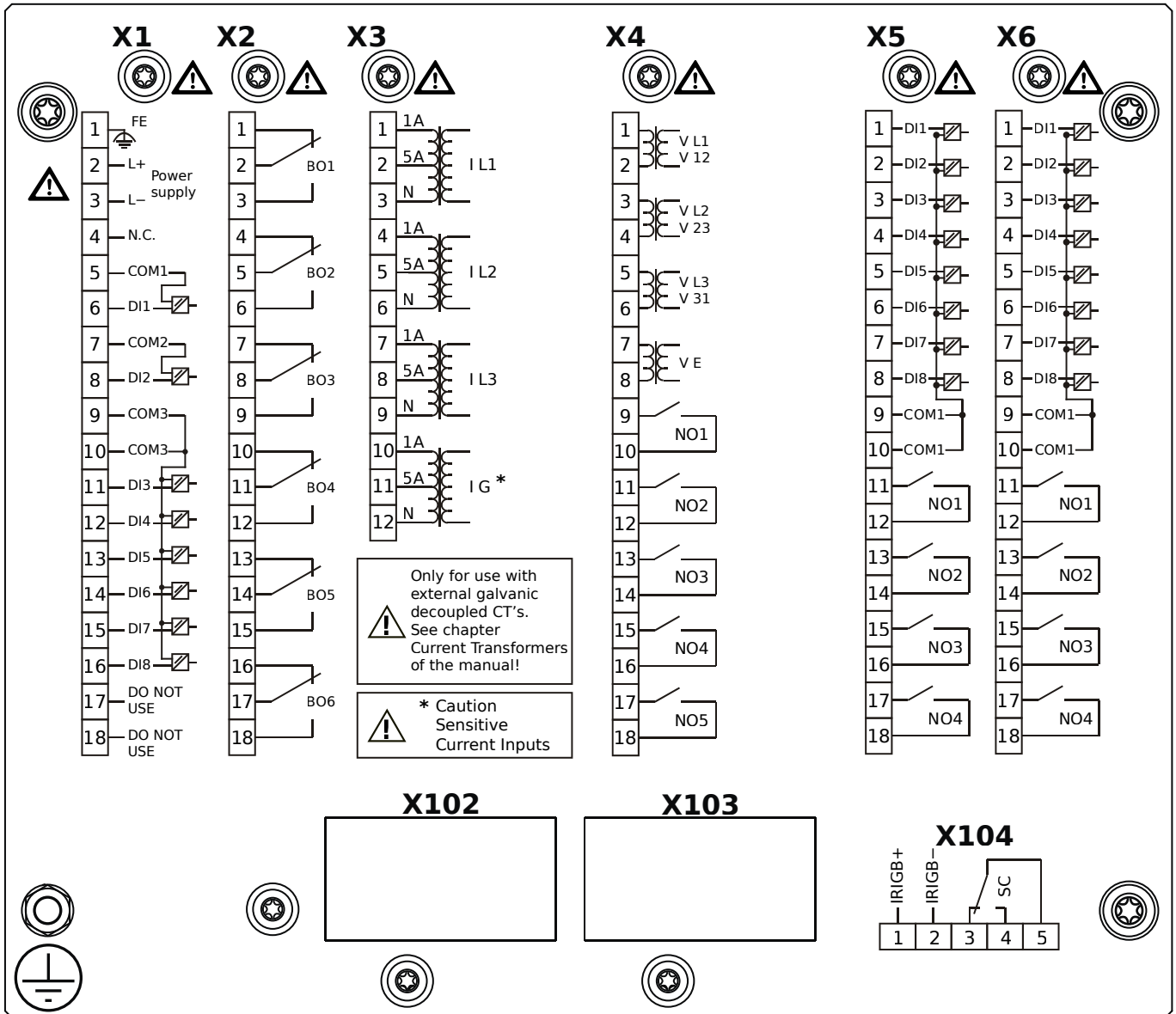

Housing B2, small display, 19" rack mounting

- X1** – DI8-X1: Wide-range power supply unit, incl. 2 non-grouped digital inputs and 6 grouped digital inputs
- X2** – OR6: Assembly Group with 6 Output Relays (Changeover / Form C)
- X3** – TIs: Standard phase current measuring card and sensitive ground current measuring
- X4** – TU-OR5: Voltage measuring (0 ... 300 VAC) assembly group with 5 additional Output Relays (NO / Form A)
- X5** – DI8-OR4: Assembly Group with 8 Digital Inputs and 4 Output Relays (NO / Form A)
- X6** – DI8-OR4: Assembly Group with 8 Digital Inputs and 4 Output Relays (NO / Form A)
- X104** – IRIG-B00X, incl. System Contact (Supervision Contact)

MRA4-2E1BAB

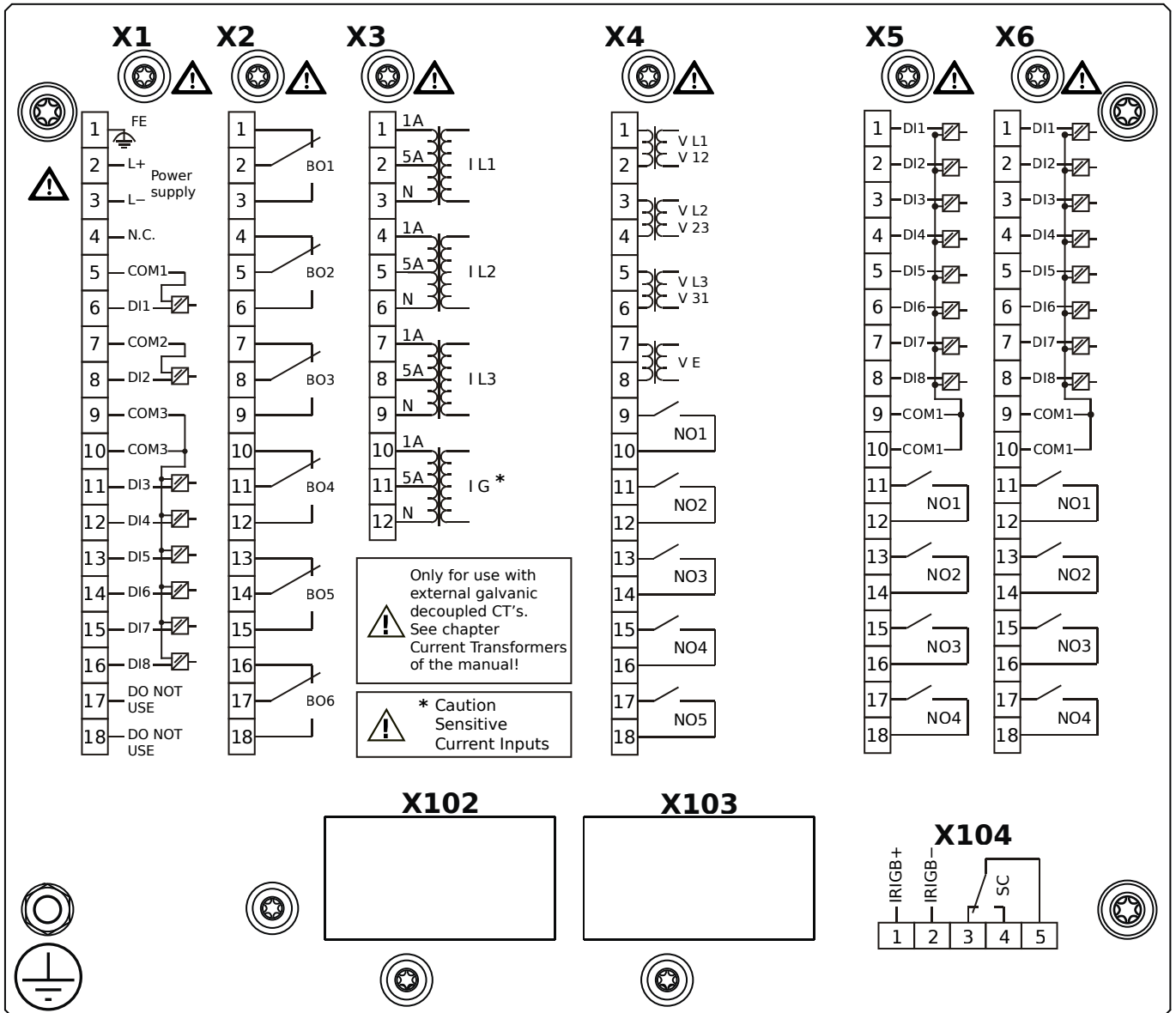

Housing B2, small display, 19" rack mounting

+ Conformal Coating (for installations in harsh environment)

- X1** – DI8-X1: Wide-range power supply unit, incl. 2 non-grouped digital inputs and 6 grouped digital inputs
- X2** – OR6: Assembly Group with 6 Output Relays (Changeover / Form C)
- X3** – TIs: Standard phase current measuring card and sensitive ground current measuring
- X4** – TU-OR5: Voltage measuring (0 ... 300 VAC) assembly group with 5 additional Output Relays (NO / Form A)
- X5** – DI8-OR4: Assembly Group with 8 Digital Inputs and 4 Output Relays (NO / Form A)
- X6** – DI8-OR4: Assembly Group with 8 Digital Inputs and 4 Output Relays (NO / Form A)
- X104** – IRIG-B00X, incl. System Contact (Supervision Contact)

MRA4-2E1BBA

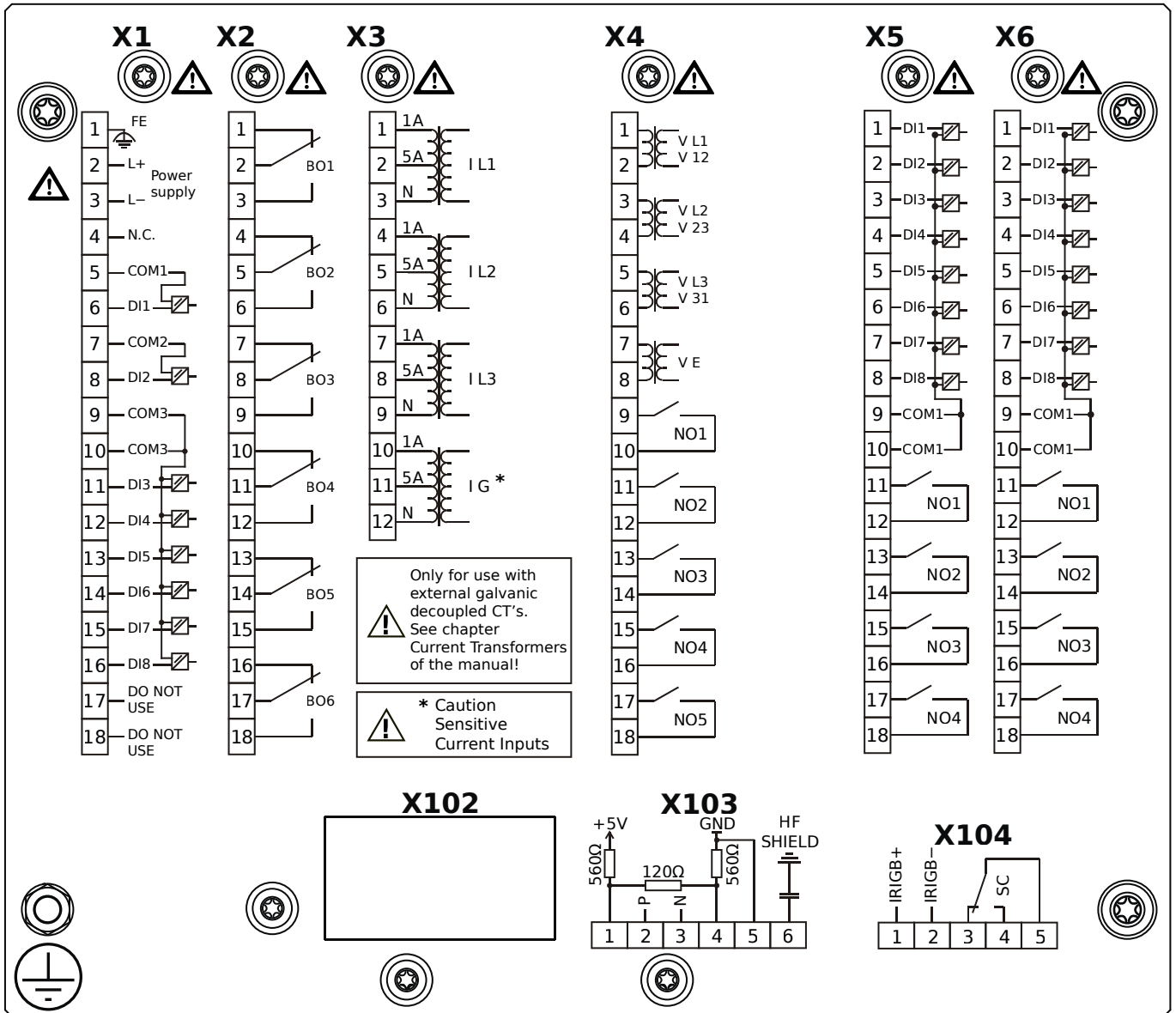

Housing B2, small display, 19" rack mounting

- X1** – DI8-X1: Wide-range power supply unit, incl. 2 non-grouped digital inputs and 6 grouped digital inputs
- X2** – OR6: Assembly Group with 6 Output Relays (Changeover / Form C)
- X3** – TIs: Standard phase current measuring card and sensitive ground current measuring
- X4** – TU-OR5: Voltage measuring (0 ... 300 VAC) assembly group with 5 additional Output Relays (NO / Form A)
- X5** – DI8-OR4: Assembly Group with 8 Digital Inputs and 4 Output Relays (NO / Form A)
- X6** – DI8-OR4: Assembly Group with 8 Digital Inputs and 4 Output Relays (NO / Form A)
- X103** – Modbus RTU / IEC 60870-5-103 / DNP3.0 RTU, RS485, Terminals
- X104** – IRIG-B00X, incl. System Contact (Supervision Contact)

MRA4-2E1BBB

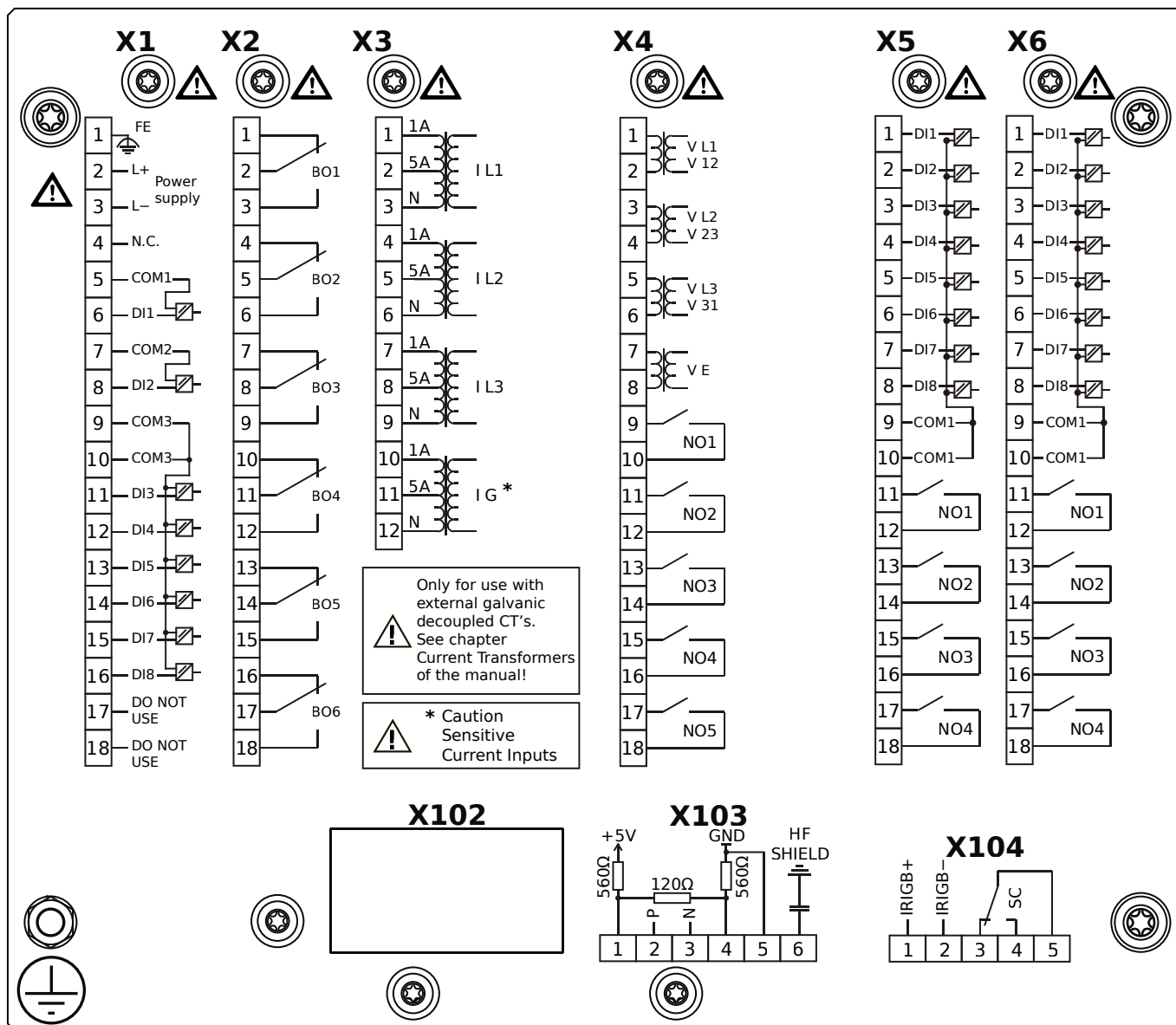

Housing B2, small display, 19" rack mounting

+ Conformal Coating (for installations in harsh environment)

- X1** – DI8-X1: Wide-range power supply unit, incl. 2 non-grouped digital inputs and 6 grouped digital inputs
- X2** – OR6: Assembly Group with 6 Output Relays (Changeover / Form C)
- X3** – TIs: Standard phase current measuring card and sensitive ground current measuring
- X4** – TU-OR5: Voltage measuring (0 ... 300 VAC) assembly group with 5 additional Output Relays (NO / Form A)
- X5** – DI8-OR4: Assembly Group with 8 Digital Inputs and 4 Output Relays (NO / Form A)
- X6** – DI8-OR4: Assembly Group with 8 Digital Inputs and 4 Output Relays (NO / Form A)
- X103** – Modbus RTU / IEC 60870-5-103 / DNP3.0 RTU, RS485, Terminals
- X104** – IRIG-B00X, incl. System Contact (Supervision Contact)

MRA4-2E1BCA

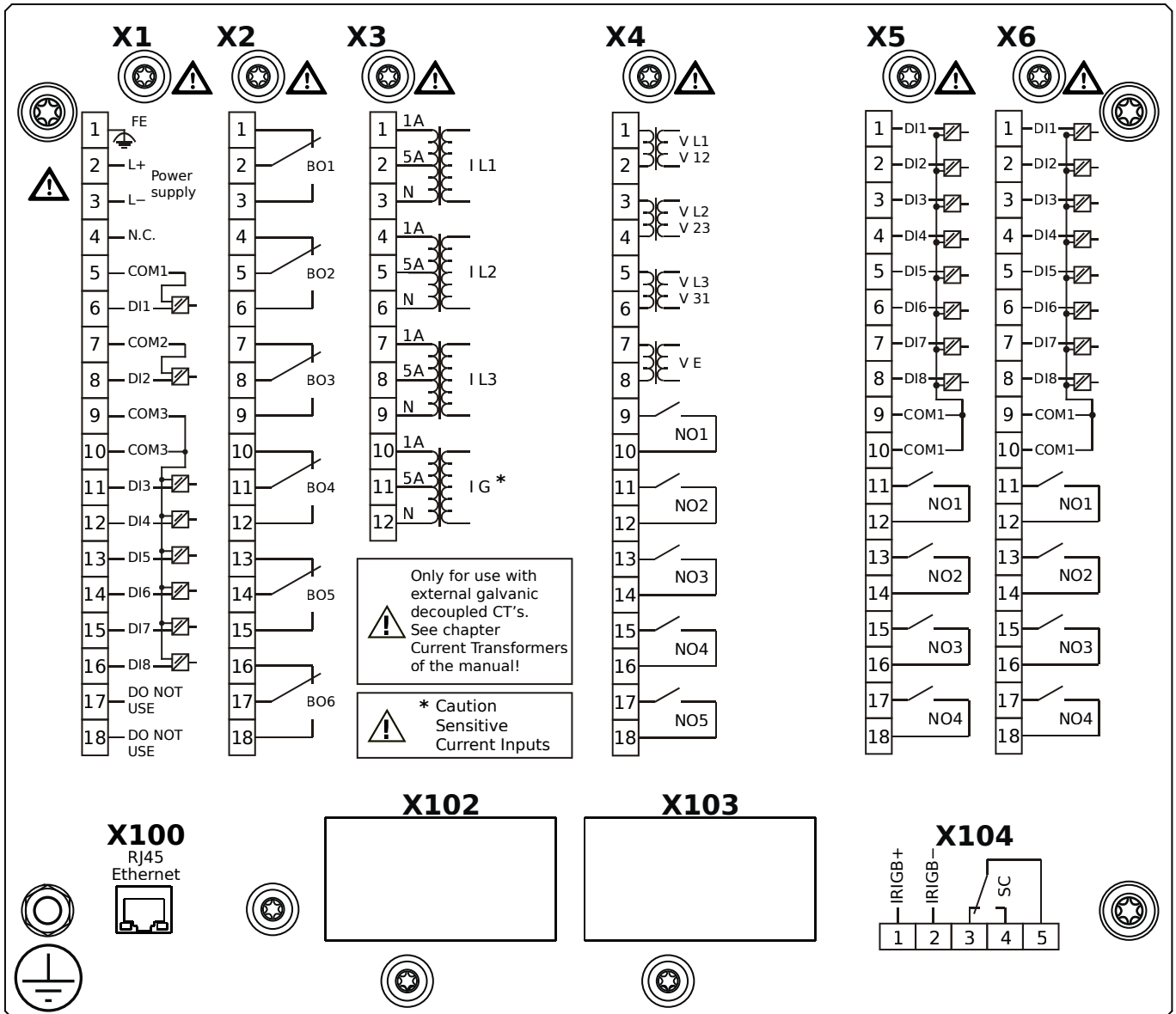

Housing B2, small display, 19" rack mounting

- X1** – DI8-X1: Wide-range power supply unit, incl. 2 non-grouped digital inputs and 6 grouped digital inputs
- X2** – OR6: Assembly Group with 6 Output Relays (Changeover / Form C)
- X3** – TIs: Standard phase current measuring card and sensitive ground current measuring
- X4** – TU-OR5: Voltage measuring (0 ... 300 VAC) assembly group with 5 additional Output Relays (NO / Form A)
- X5** – DI8-OR4: Assembly Group with 8 Digital Inputs and 4 Output Relays (NO / Form A)
- X6** – DI8-OR4: Assembly Group with 8 Digital Inputs and 4 Output Relays (NO / Form A)
- X100** – Modbus TCP / DNP3.0 TCP/UDP, Ethernet interface, 100 Mbit/s, RJ45 (BASE100-FX)
- X104** – IRIG-B00X, incl. System Contact (Supervision Contact)

MRA4-2E1BCB

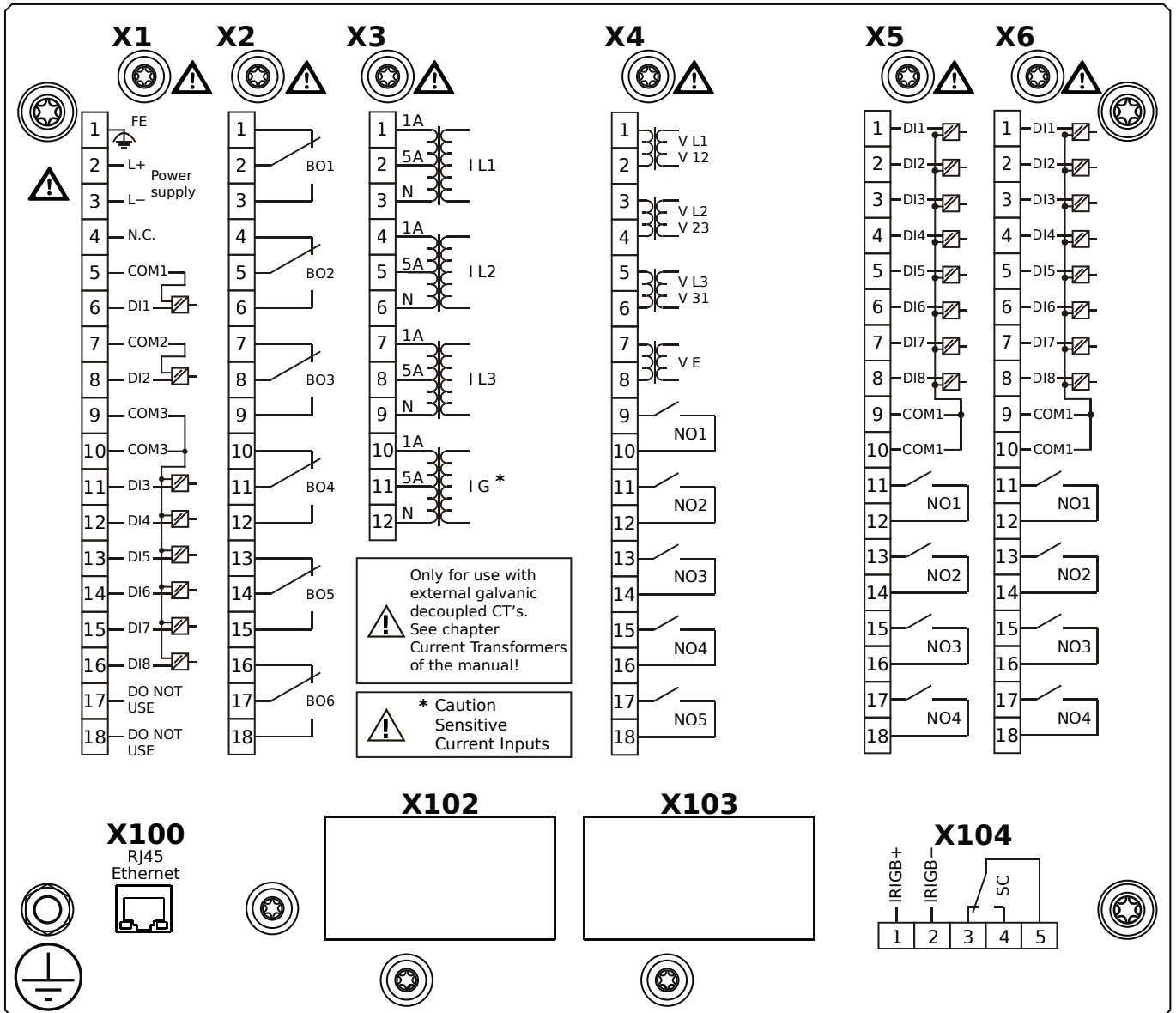

Housing B2, small display, 19" rack mounting

+ Conformal Coating (for installations in harsh environment)

- X1** – DI8-X1: Wide-range power supply unit, incl. 2 non-grouped digital inputs and 6 grouped digital inputs
- X2** – OR6: Assembly Group with 6 Output Relays (Changeover / Form C)
- X3** – TIs: Standard phase current measuring card and sensitive ground current measuring
- X4** – TU-OR5: Voltage measuring (0 ... 300 VAC) assembly group with 5 additional Output Relays (NO / Form A)
- X5** – DI8-OR4: Assembly Group with 8 Digital Inputs and 4 Output Relays (NO / Form A)
- X6** – DI8-OR4: Assembly Group with 8 Digital Inputs and 4 Output Relays (NO / Form A)
- X100** – Modbus TCP / DNP3.0 TCP/UDP, Ethernet interface, 100 Mbit/s, RJ45 (BASE100-FX)
- X104** – IRIG-B00X, incl. System Contact (Supervision Contact)

MRA4-2E1BDA

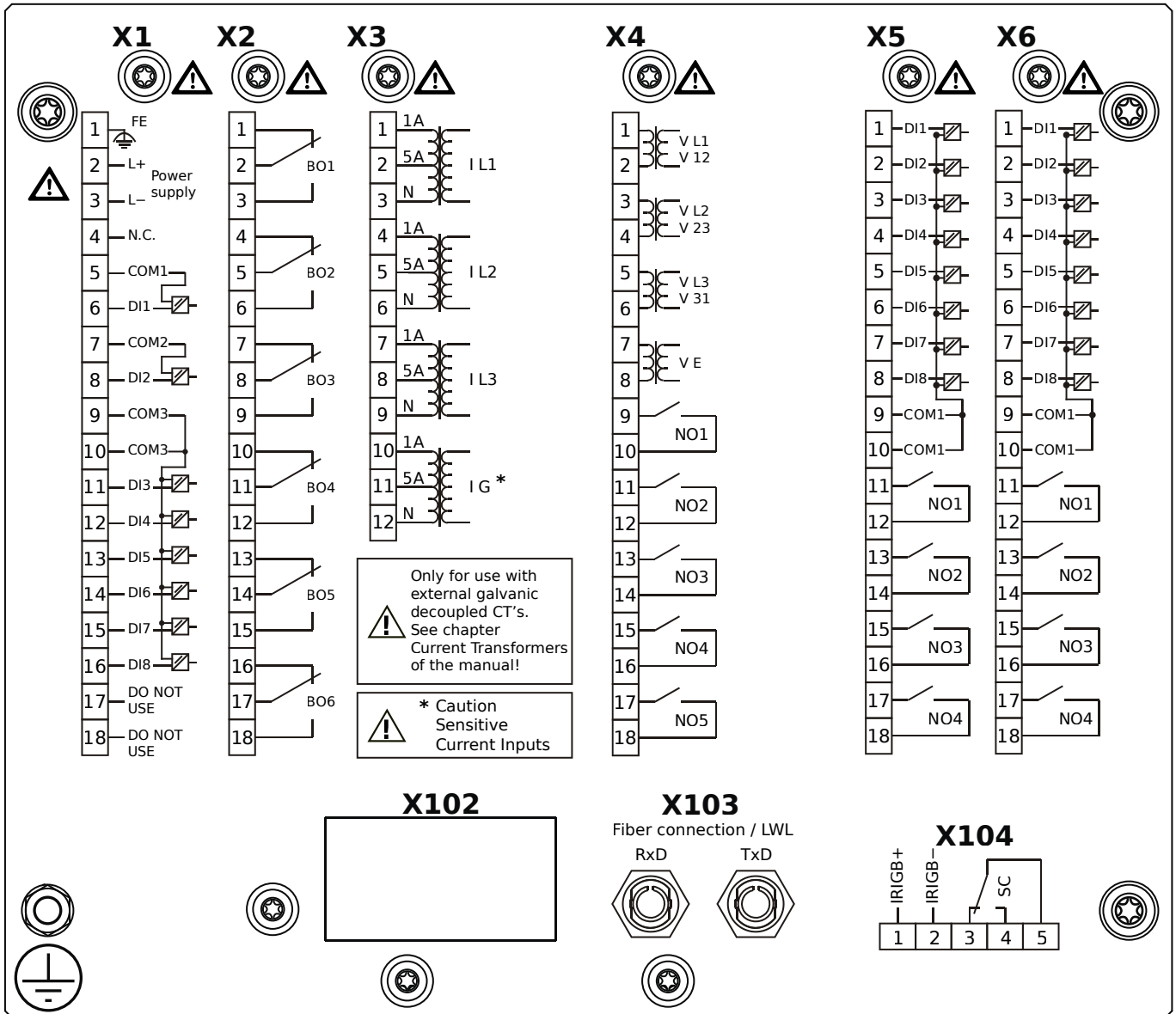

Housing B2, small display, 19" rack mounting

- X1** – DI8-X1: Wide-range power supply unit, incl. 2 non-grouped digital inputs and 6 grouped digital inputs
- X2** – OR6: Assembly Group with 6 Output Relays (Changeover / Form C)
- X3** – TIs: Standard phase current measuring card and sensitive ground current measuring
- X4** – TU-OR5: Voltage measuring (0 ... 300 VAC) assembly group with 5 additional Output Relays (NO / Form A)
- X5** – DI8-OR4: Assembly Group with 8 Digital Inputs and 4 Output Relays (NO / Form A)
- X6** – DI8-OR4: Assembly Group with 8 Digital Inputs and 4 Output Relays (NO / Form A)
- X103** – Profibus-DP, Fiber optics interface, ST Connector
- X104** – IRIG-B00X, incl. System Contact (Supervision Contact)

MRA4-2E1BDB

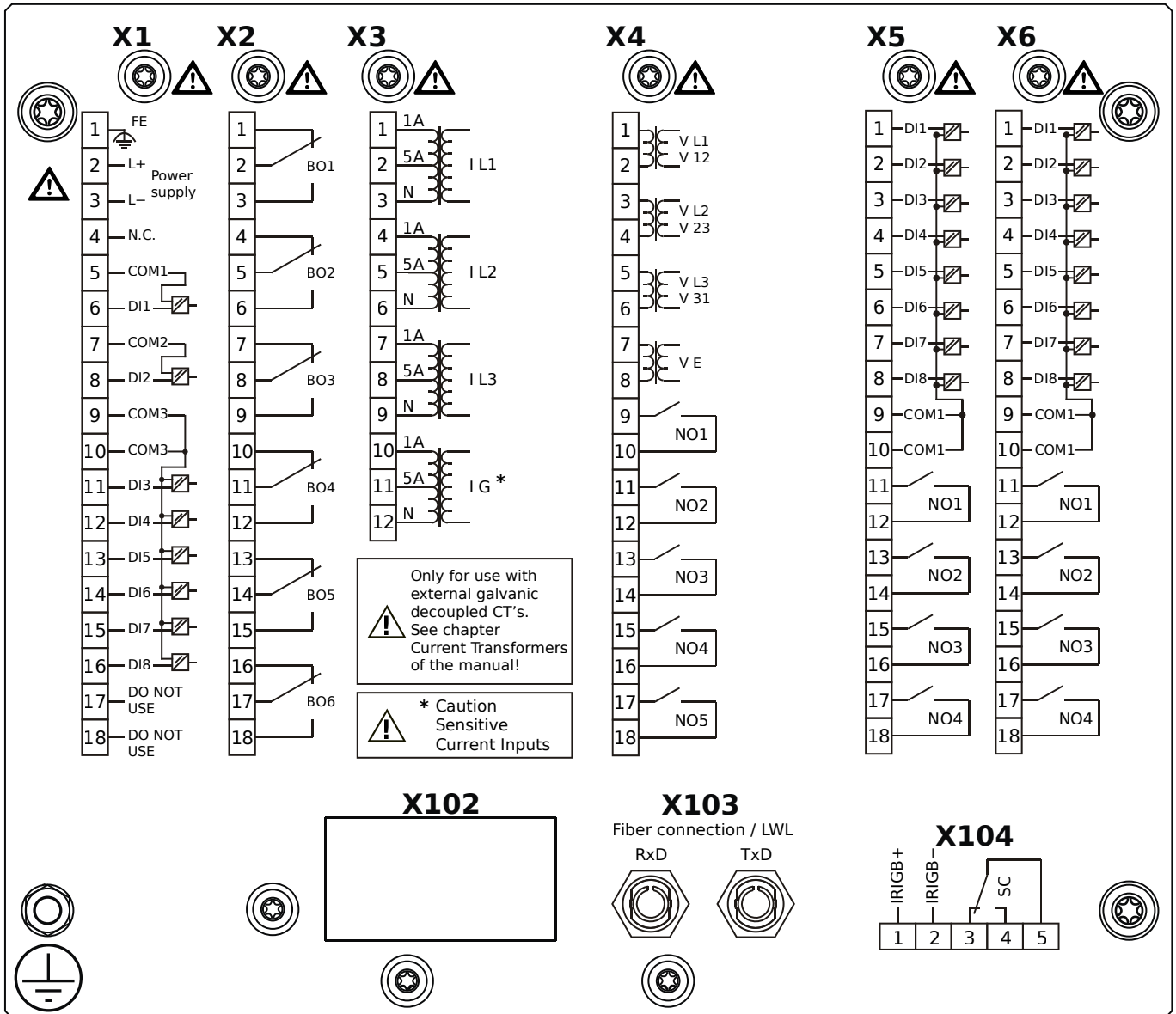

Housing B2, small display, 19" rack mounting

+ Conformal Coating (for installations in harsh environment)

- X1** – DI8-X1: Wide-range power supply unit, incl. 2 non-grouped digital inputs and 6 grouped digital inputs
- X2** – OR6: Assembly Group with 6 Output Relays (Changeover / Form C)
- X3** – TIs: Standard phase current measuring card and sensitive ground current measuring
- X4** – TU-OR5: Voltage measuring (0 ... 300 VAC) assembly group with 5 additional Output Relays (NO / Form A)
- X5** – DI8-OR4: Assembly Group with 8 Digital Inputs and 4 Output Relays (NO / Form A)
- X6** – DI8-OR4: Assembly Group with 8 Digital Inputs and 4 Output Relays (NO / Form A)
- X103** – Profibus-DP, Fiber optics interface, ST Connector
- X104** – IRIG-B00X, incl. System Contact (Supervision Contact)

MRA4-2E1BEA

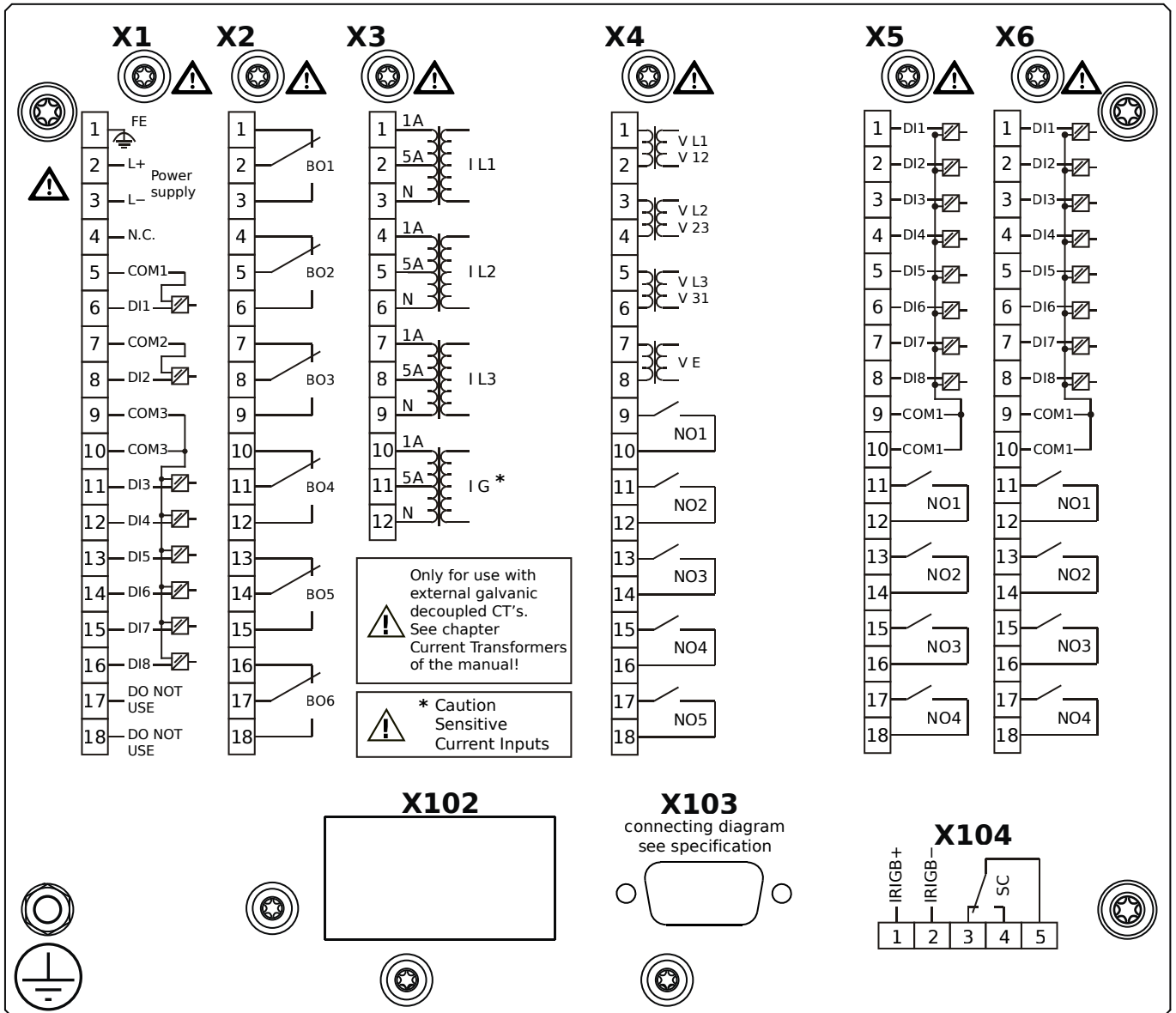

Housing B2, small display, 19" rack mounting

- X1** – DI8-X1: Wide-range power supply unit, incl. 2 non-grouped digital inputs and 6 grouped digital inputs
- X2** – OR6: Assembly Group with 6 Output Relays (Changeover / Form C)
- X3** – TIs: Standard phase current measuring card and sensitive ground current measuring
- X4** – TU-OR5: Voltage measuring (0 ... 300 VAC) assembly group with 5 additional Output Relays (NO / Form A)
- X5** – DI8-OR4: Assembly Group with 8 Digital Inputs and 4 Output Relays (NO / Form A)
- X6** – DI8-OR4: Assembly Group with 8 Digital Inputs and 4 Output Relays (NO / Form A)
- X103** – Profibus-DP, RS485, D-SUB
- X104** – IRIG-B00X, incl. System Contact (Supervision Contact)

MRA4-2E1BEB

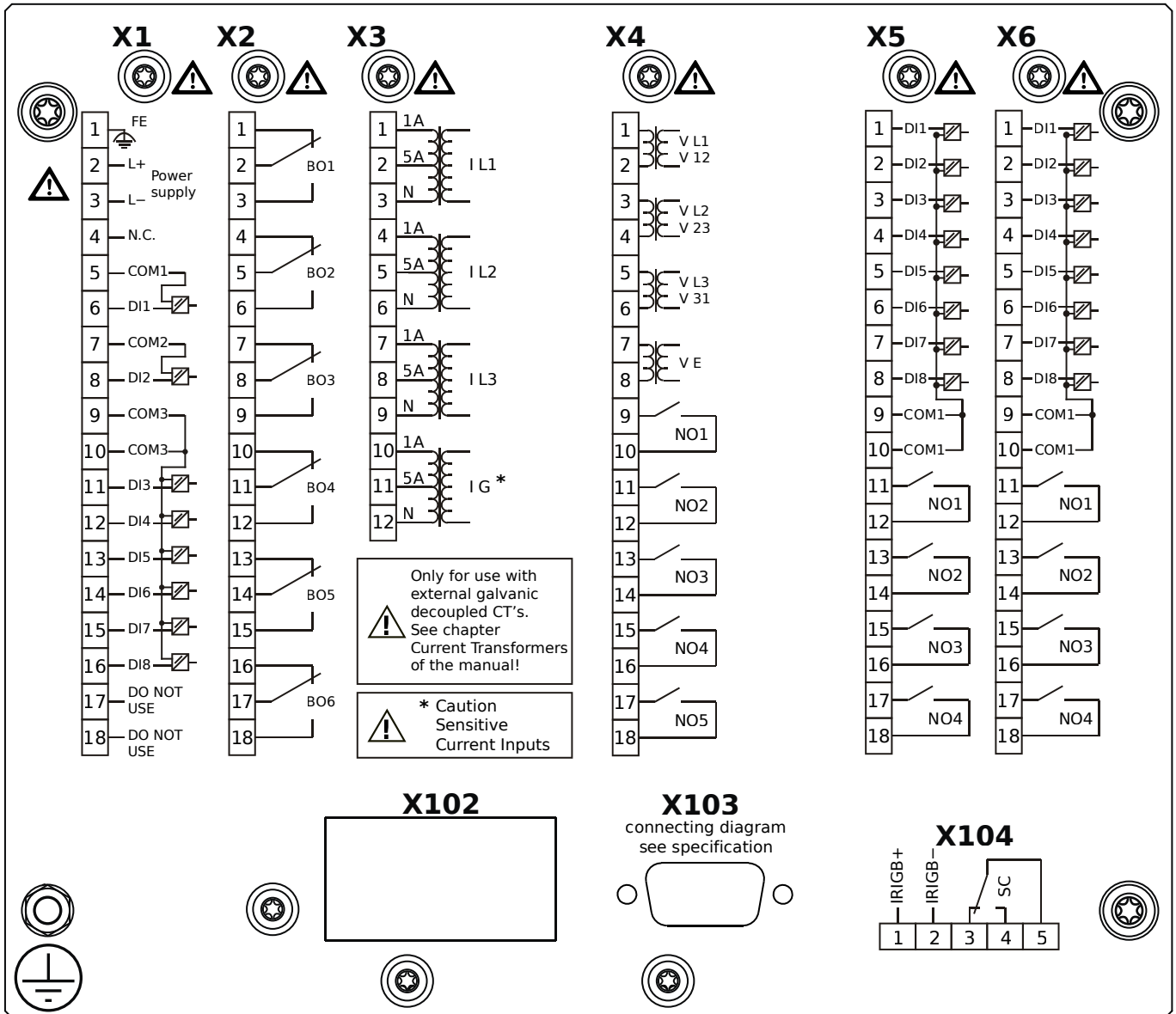

Housing B2, small display, 19" rack mounting

+ Conformal Coating (for installations in harsh environment)

- X1** – DI8-X1: Wide-range power supply unit, incl. 2 non-grouped digital inputs and 6 grouped digital inputs
- X2** – OR6: Assembly Group with 6 Output Relays (Changeover / Form C)
- X3** – TIs: Standard phase current measuring card and sensitive ground current measuring
- X4** – TU-OR5: Voltage measuring (0 ... 300 VAC) assembly group with 5 additional Output Relays (NO / Form A)
- X5** – DI8-OR4: Assembly Group with 8 Digital Inputs and 4 Output Relays (NO / Form A)
- X6** – DI8-OR4: Assembly Group with 8 Digital Inputs and 4 Output Relays (NO / Form A)
- X103** – Profibus-DP, RS485, D-SUB
- X104** – IRIG-B00X, incl. System Contact (Supervision Contact)

MRA4-2E1BFA

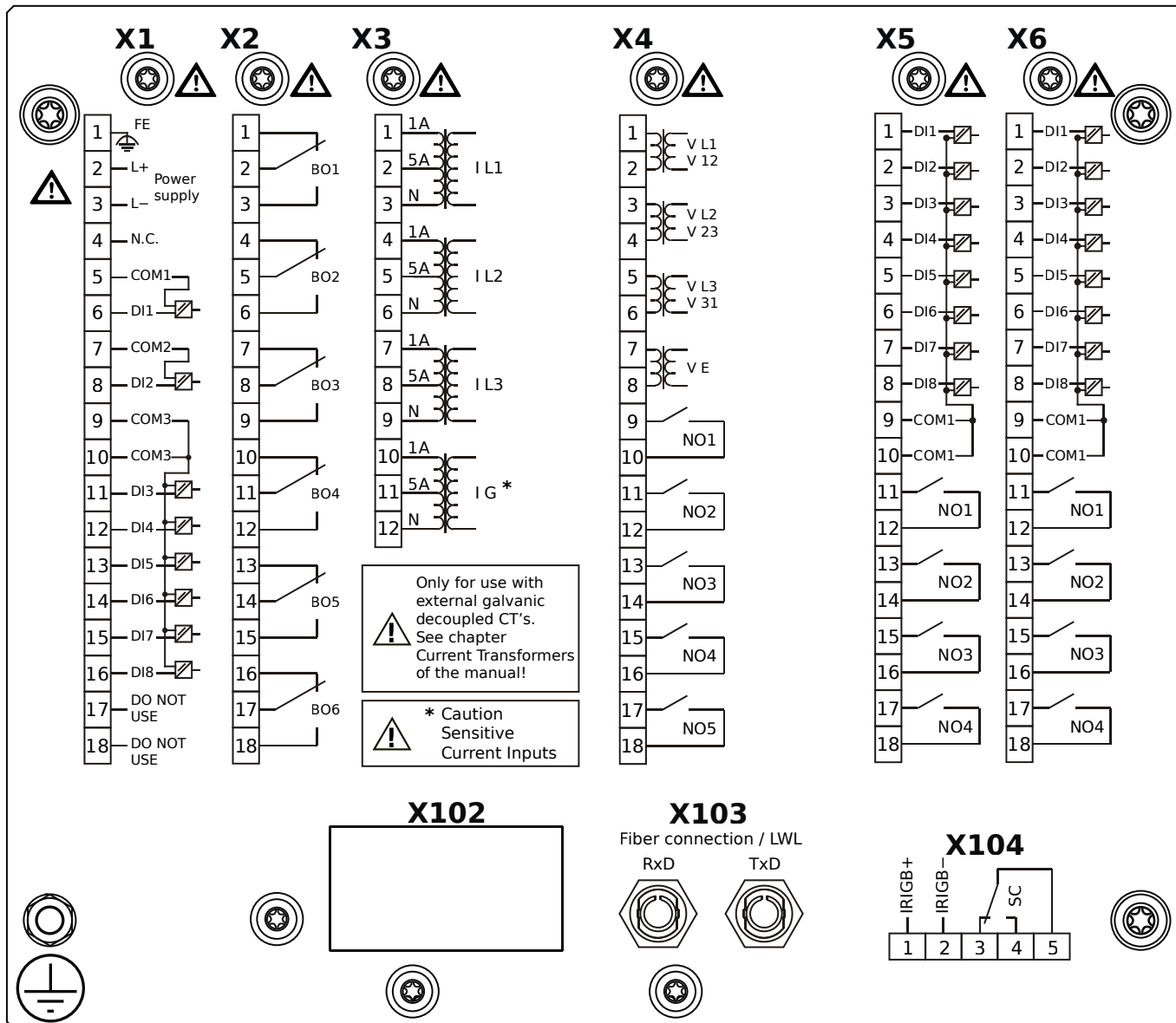

Housing B2, small display, 19" rack mounting

- X1** – DI8-X1: Wide-range power supply unit, incl. 2 non-grouped digital inputs and 6 grouped digital inputs
- X2** – OR6: Assembly Group with 6 Output Relays (Changeover / Form C)
- X3** – TIs: Standard phase current measuring card and sensitive ground current measuring
- X4** – TU-OR5: Voltage measuring (0 ... 300 VAC) assembly group with 5 additional Output Relays (NO / Form A)
- X5** – DI8-OR4: Assembly Group with 8 Digital Inputs and 4 Output Relays (NO / Form A)
- X6** – DI8-OR4: Assembly Group with 8 Digital Inputs and 4 Output Relays (NO / Form A)
- X103** – Modbus RTU / IEC 60870-5-103 / DNP3.0 RTU, Fiber optics interface, ST Connector
- X104** – IRIG-B00X, incl. System Contact (Supervision Contact)

MRA4-2E1BFB

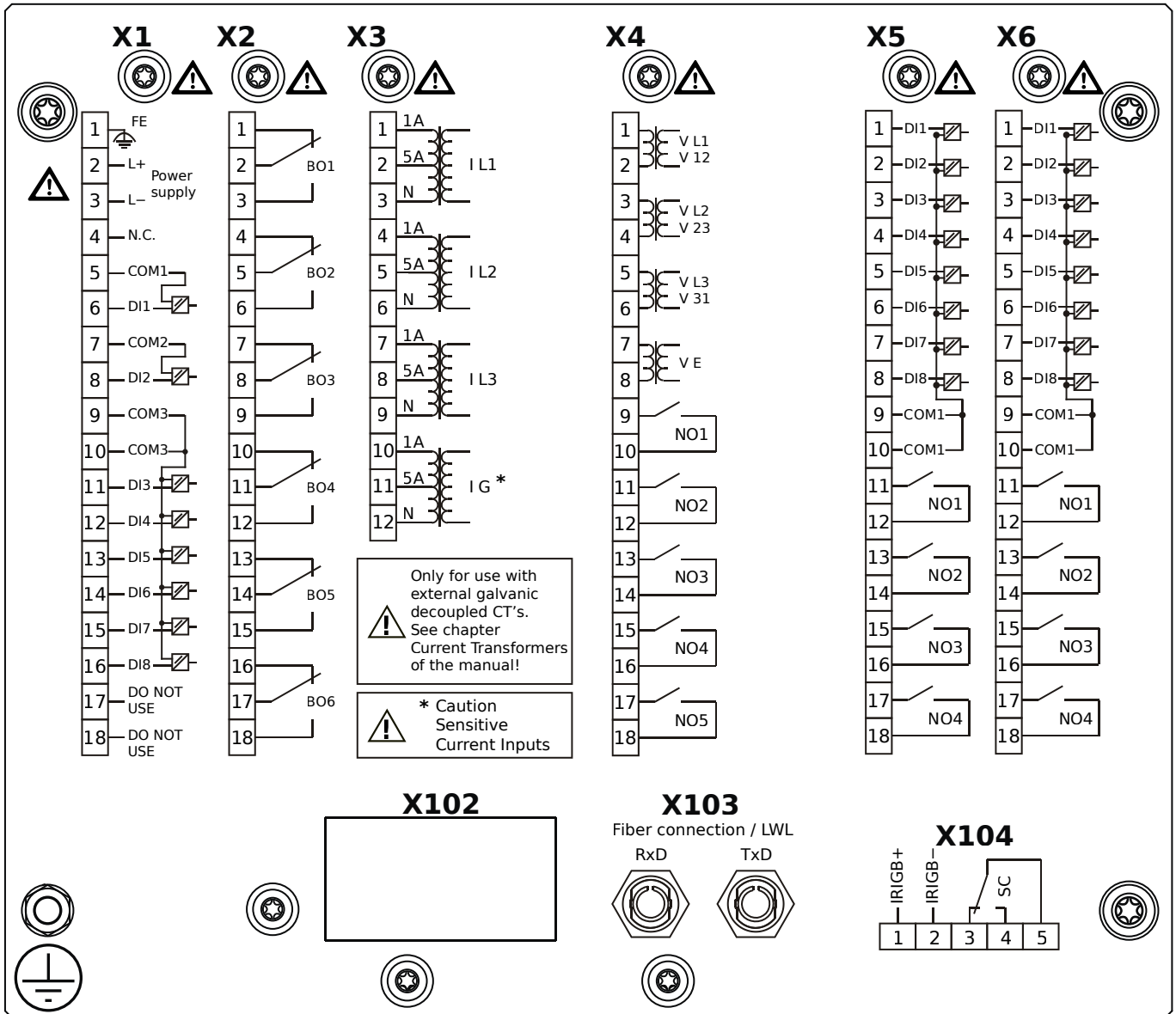

Housing B2, small display, 19" rack mounting

+ Conformal Coating (for installations in harsh environment)

- X1** – DI8-X1: Wide-range power supply unit, incl. 2 non-grouped digital inputs and 6 grouped digital inputs
- X2** – OR6: Assembly Group with 6 Output Relays (Changeover / Form C)
- X3** – TIs: Standard phase current measuring card and sensitive ground current measuring
- X4** – TU-OR5: Voltage measuring (0 ... 300 VAC) assembly group with 5 additional Output Relays (NO / Form A)
- X5** – DI8-OR4: Assembly Group with 8 Digital Inputs and 4 Output Relays (NO / Form A)
- X6** – DI8-OR4: Assembly Group with 8 Digital Inputs and 4 Output Relays (NO / Form A)
- X103** – Modbus RTU / IEC 60870-5-103 / DNP3.0 RTU, Fiber optics interface, ST Connector
- X104** – IRIG-B00X, incl. System Contact (Supervision Contact)

MRA4-2E1BGA

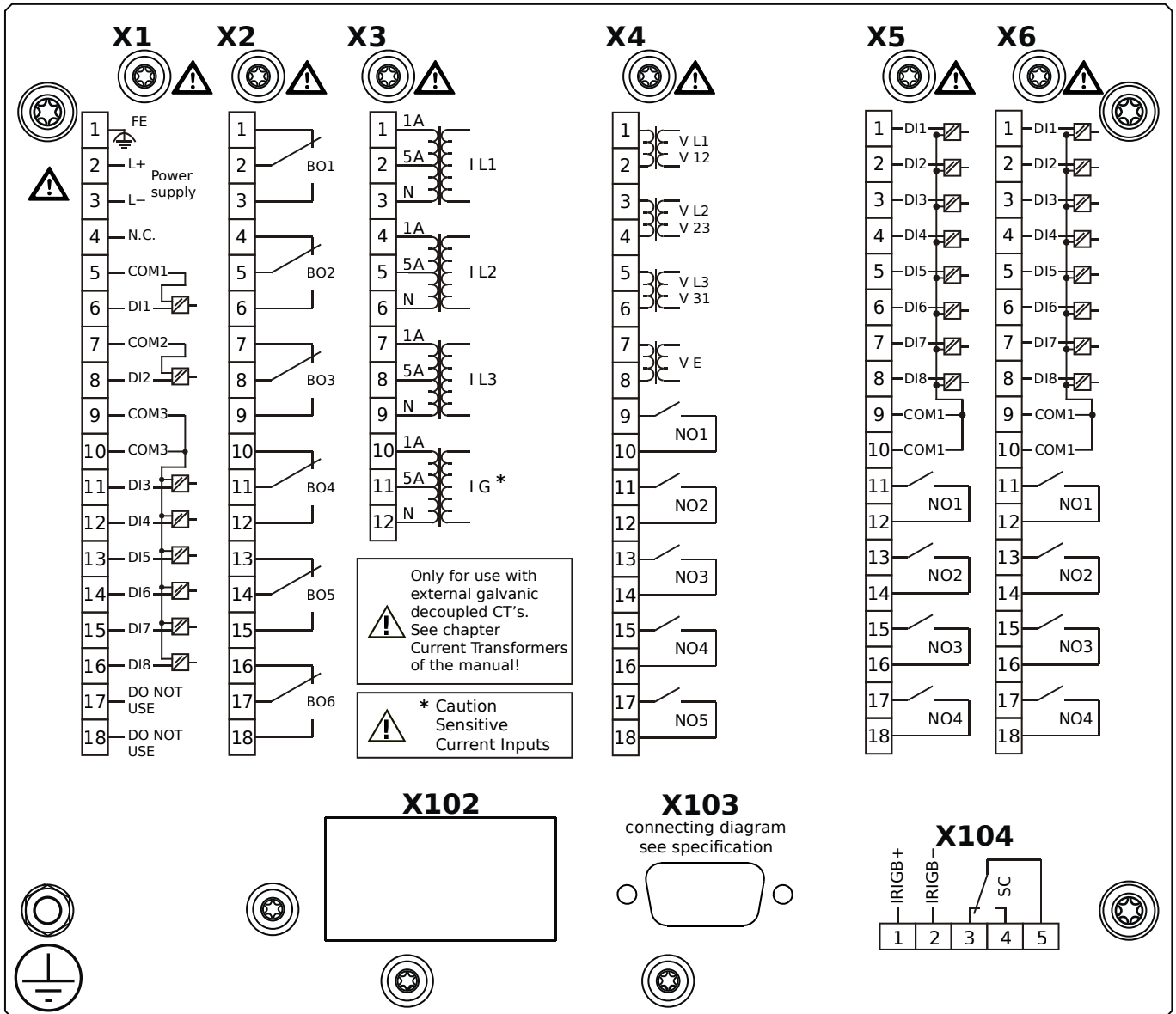

Housing B2, small display, 19" rack mounting

- X1** – DI8-X1: Wide-range power supply unit, incl. 2 non-grouped digital inputs and 6 grouped digital inputs
- X2** – OR6: Assembly Group with 6 Output Relays (Changeover / Form C)
- X3** – TIs: Standard phase current measuring card and sensitive ground current measuring
- X4** – TU-OR5: Voltage measuring (0 ... 300 VAC) assembly group with 5 additional Output Relays (NO / Form A)
- X5** – DI8-OR4: Assembly Group with 8 Digital Inputs and 4 Output Relays (NO / Form A)
- X6** – DI8-OR4: Assembly Group with 8 Digital Inputs and 4 Output Relays (NO / Form A)
- X103** – Modbus RTU / IEC 60870-5-103 / DNP3.0 RTU, RS485, D-SUB
- X104** – IRIG-B00X, incl. System Contact (Supervision Contact)

MRA4-2E1BGB

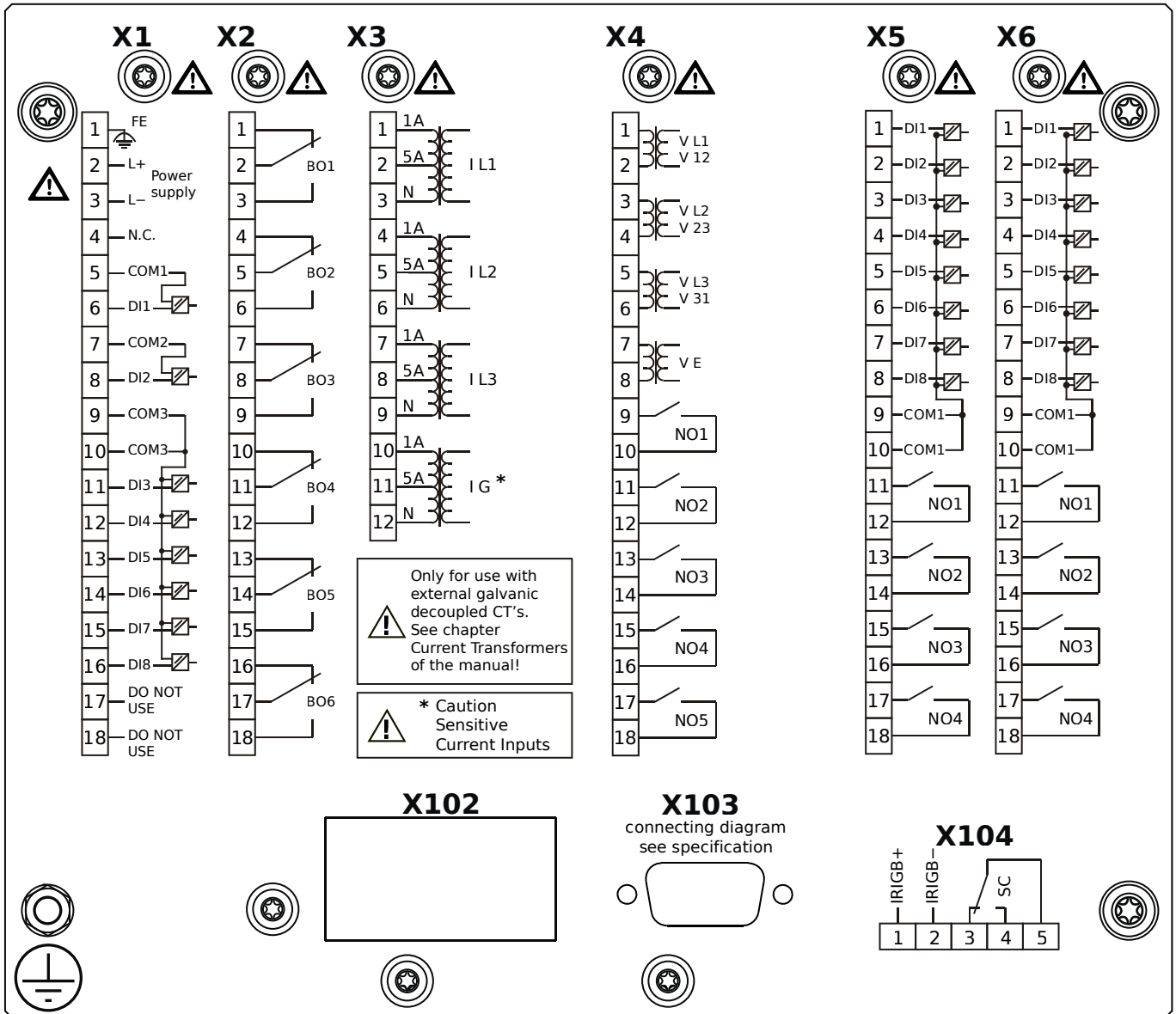

Housing B2, small display, 19" rack mounting

+ Conformal Coating (for installations in harsh environment)

- X1** – DI8-X1: Wide-range power supply unit, incl. 2 non-grouped digital inputs and 6 grouped digital inputs
- X2** – OR6: Assembly Group with 6 Output Relays (Changeover / Form C)
- X3** – TIs: Standard phase current measuring card and sensitive ground current measuring
- X4** – TU-OR5: Voltage measuring (0 ... 300 VAC) assembly group with 5 additional Output Relays (NO / Form A)
- X5** – DI8-OR4: Assembly Group with 8 Digital Inputs and 4 Output Relays (NO / Form A)
- X6** – DI8-OR4: Assembly Group with 8 Digital Inputs and 4 Output Relays (NO / Form A)
- X103** – Modbus RTU / IEC 60870-5-103 / DNP3.0 RTU, RS485, D-SUB
- X104** – IRIG-B00X, incl. System Contact (Supervision Contact)

MRA4-2E1BHA

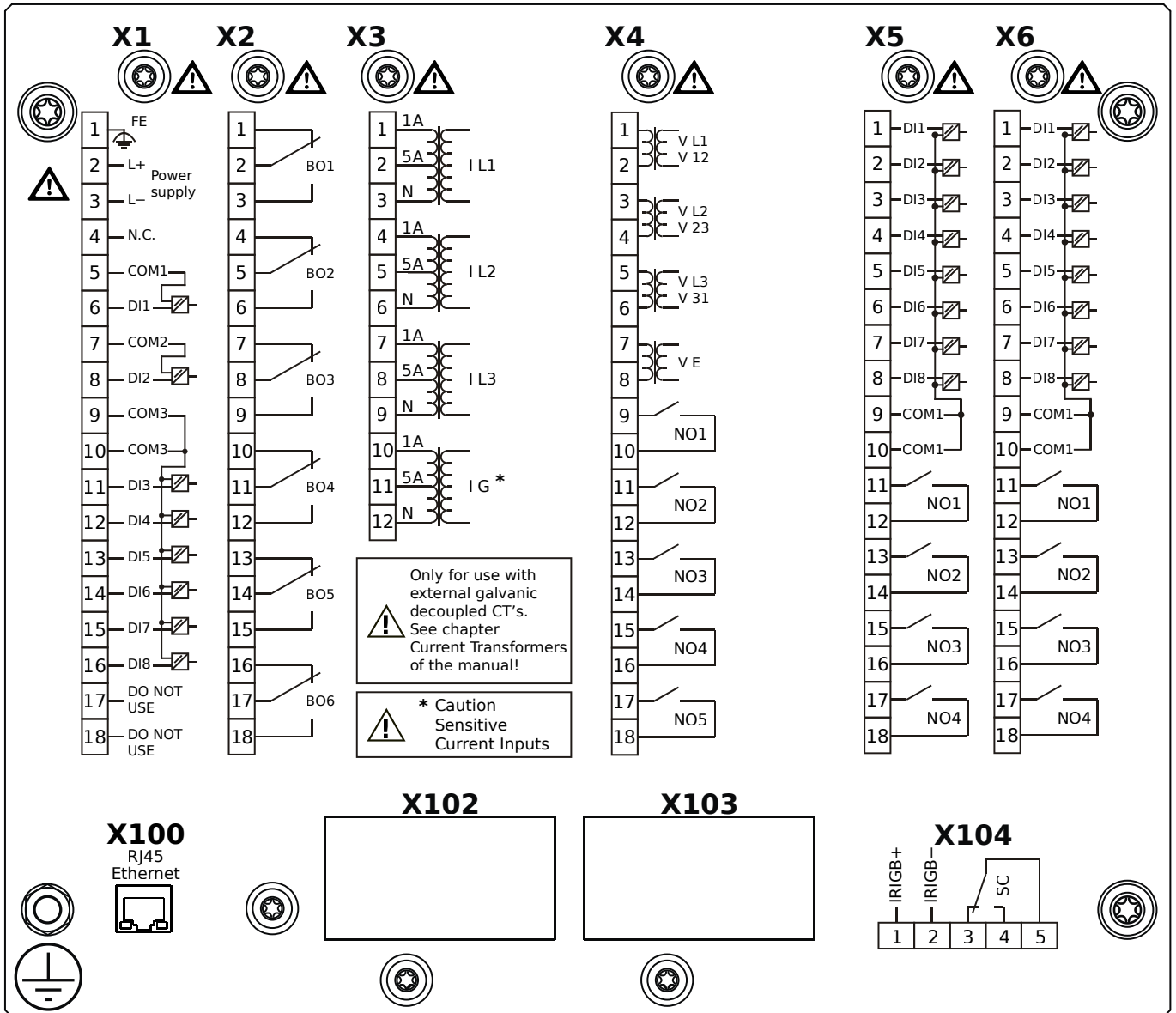

Housing B2, small display, 19" rack mounting

- X1** – DI8-X1: Wide-range power supply unit, incl. 2 non-grouped digital inputs and 6 grouped digital inputs
- X2** – OR6: Assembly Group with 6 Output Relays (Changeover / Form C)
- X3** – TIs: Standard phase current measuring card and sensitive ground current measuring
- X4** – TU-OR5: Voltage measuring (0 ... 300 VAC) assembly group with 5 additional Output Relays (NO / Form A)
- X5** – DI8-OR4: Assembly Group with 8 Digital Inputs and 4 Output Relays (NO / Form A)
- X6** – DI8-OR4: Assembly Group with 8 Digital Inputs and 4 Output Relays (NO / Form A)
- X100** – IEC 61850 / Modbus TCP / DNP3.0 TCP/UDP, Ethernet interface, 100 Mbit/s, RJ45 (BASE100-FX)
- X104** – IRIG-B00X, incl. System Contact (Supervision Contact)

MRA4-2E1BHB

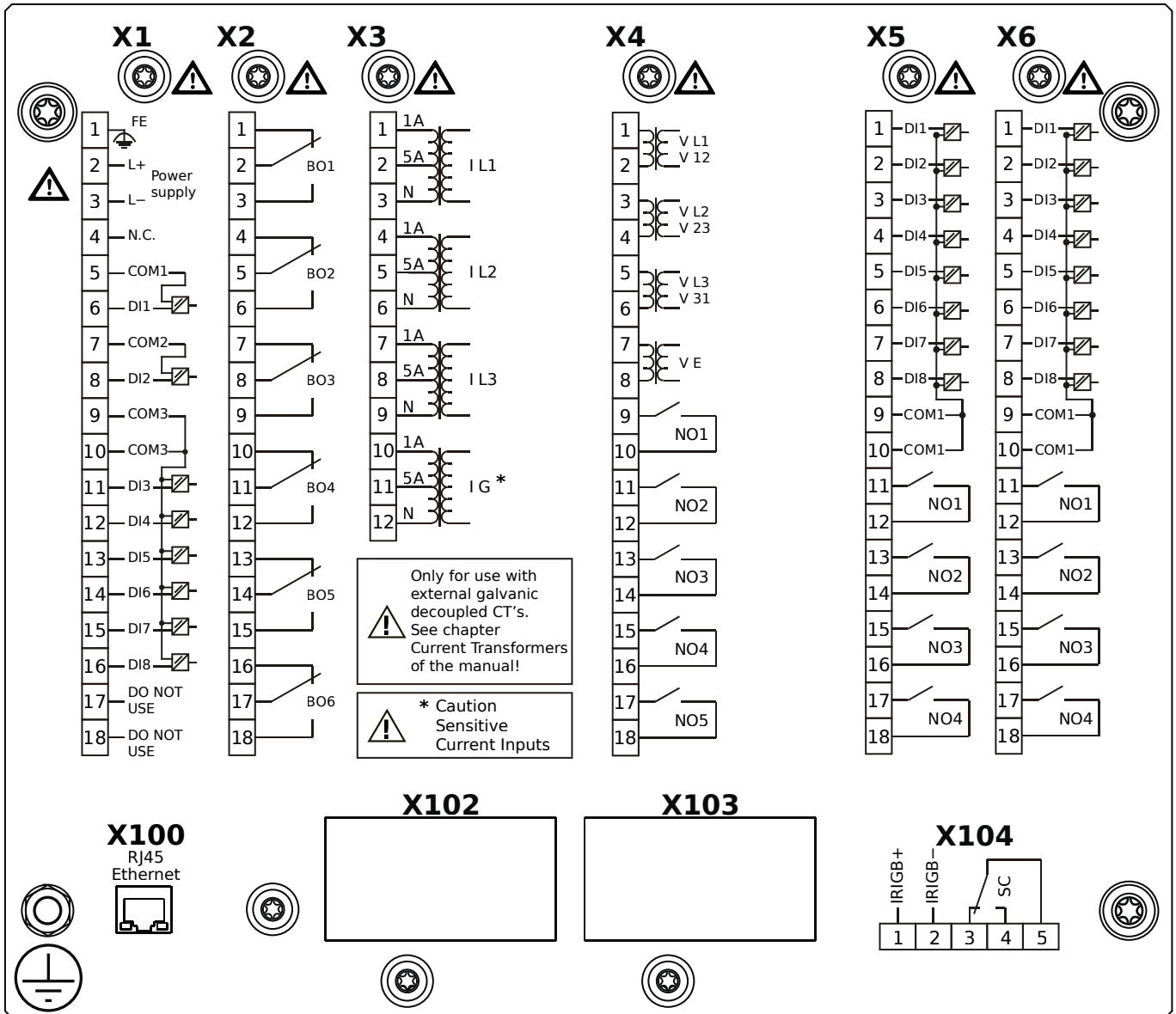

Housing B2, small display, 19" rack mounting

+ Conformal Coating (for installations in harsh environment)

- X1** – DI8-X1: Wide-range power supply unit, incl. 2 non-grouped digital inputs and 6 grouped digital inputs
- X2** – OR6: Assembly Group with 6 Output Relays (Changeover / Form C)
- X3** – TIs: Standard phase current measuring card and sensitive ground current measuring
- X4** – TU-OR5: Voltage measuring (0 ... 300 VAC) assembly group with 5 additional Output Relays (NO / Form A)
- X5** – DI8-OR4: Assembly Group with 8 Digital Inputs and 4 Output Relays (NO / Form A)
- X6** – DI8-OR4: Assembly Group with 8 Digital Inputs and 4 Output Relays (NO / Form A)
- X100** – IEC 61850 / Modbus TCP / DNP3.0 TCP/UDP, Ethernet interface, 100 Mbit/s, RJ45 (BASE100-FX)
- X104** – IRIG-B00X, incl. System Contact (Supervision Contact)

MRA4-2E1BIA

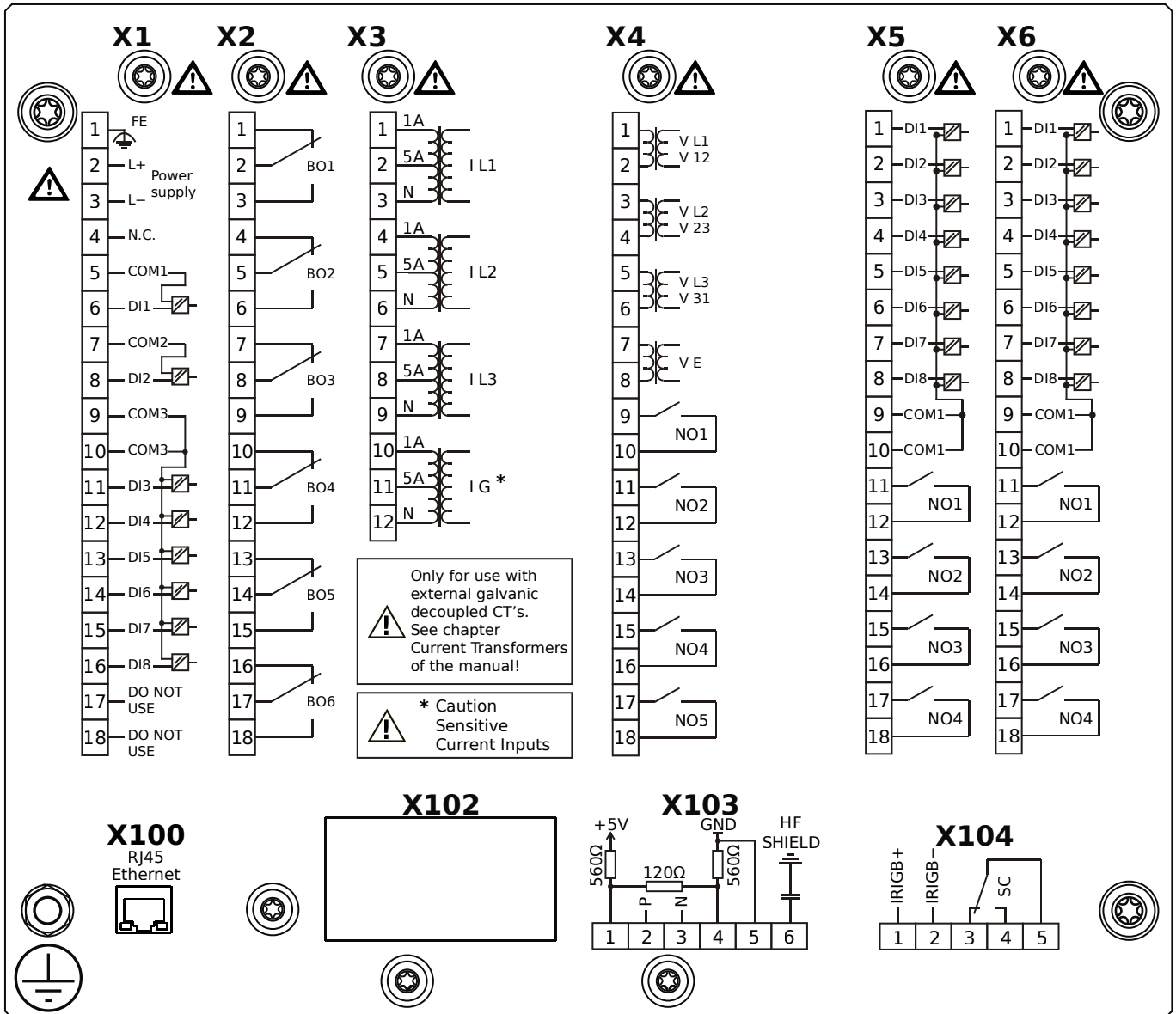

Housing B2, small display, 19" rack mounting

- X1** – DI8-X1: Wide-range power supply unit, incl. 2 non-grouped digital inputs and 6 grouped digital inputs
- X2** – OR6: Assembly Group with 6 Output Relays (Changeover / Form C)
- X3** – TIs: Standard phase current measuring card and sensitive ground current measuring
- X4** – TU-OR5: Voltage measuring (0 ... 300 VAC) assembly group with 5 additional Output Relays (NO / Form A)
- X5** – DI8-OR4: Assembly Group with 8 Digital Inputs and 4 Output Relays (NO / Form A)
- X6** – DI8-OR4: Assembly Group with 8 Digital Inputs and 4 Output Relays (NO / Form A)
- X100** – Modbus TCP / DNP3.0 TCP/UDP, Ethernet interface, 100 Mbit/s, RJ45 (BASE100-FX)
- X103** – IEC 60870-5-103 / Modbus RTU / DNP3.0 RTU, RS485, Terminals
- X104** – IRIG-B00X, incl. System Contact (Supervision Contact)

MRA4-2E1BIB

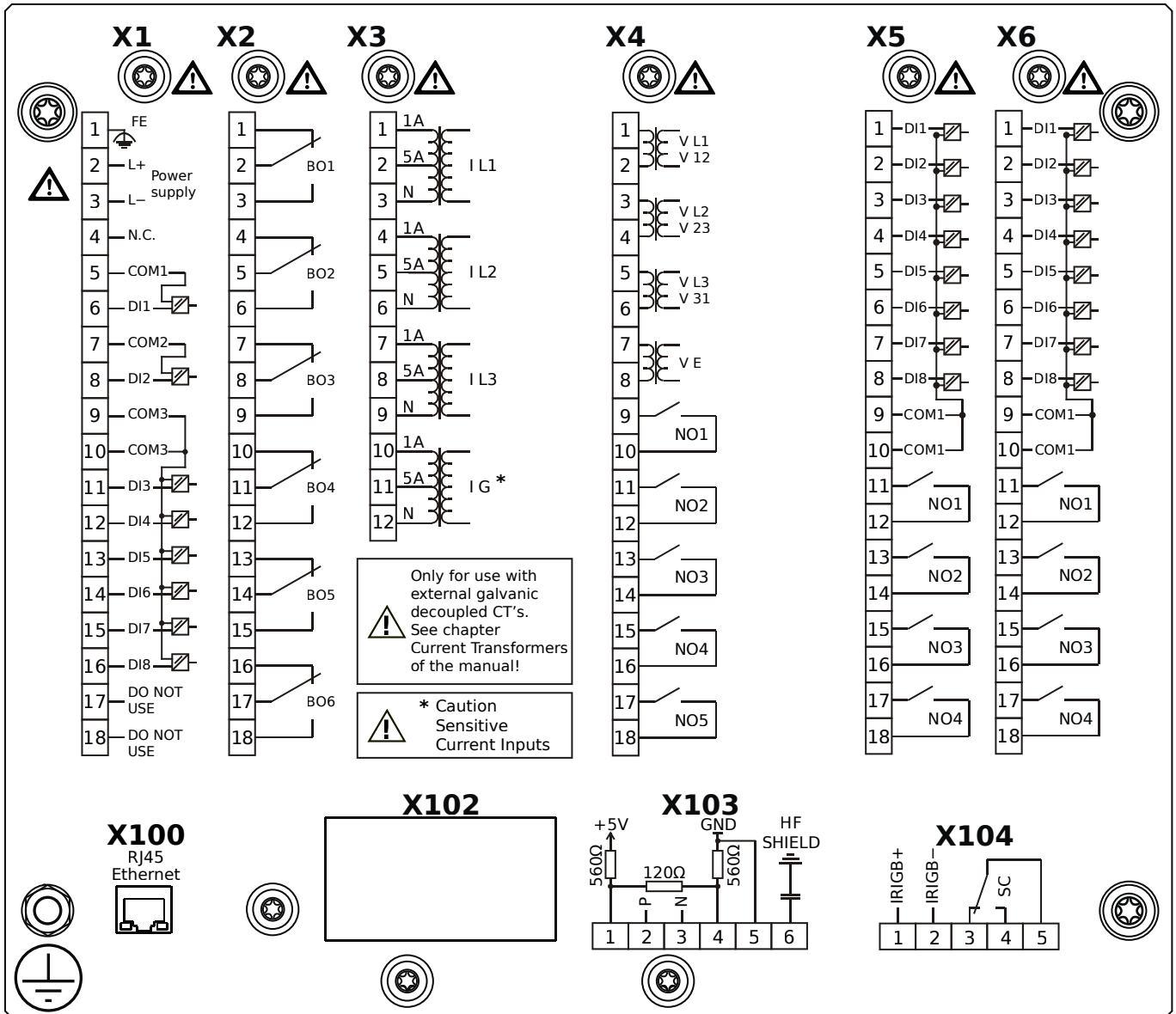

Housing B2, small display, 19" rack mounting

+ Conformal Coating (for installations in harsh environment)

- X1** – DI8-X1: Wide-range power supply unit, incl. 2 non-grouped digital inputs and 6 grouped digital inputs
- X2** – OR6: Assembly Group with 6 Output Relays (Changeover / Form C)
- X3** – TIs: Standard phase current measuring card and sensitive ground current measuring
- X4** – TU-OR5: Voltage measuring (0 ... 300 VAC) assembly group with 5 additional Output Relays (NO / Form A)
- X5** – DI8-OR4: Assembly Group with 8 Digital Inputs and 4 Output Relays (NO / Form A)
- X6** – DI8-OR4: Assembly Group with 8 Digital Inputs and 4 Output Relays (NO / Form A)
- X100** – Modbus TCP / DNP3.0 TCP/UDP, Ethernet interface, 100 Mbit/s, RJ45 (BASE100-FX)
- X103** – IEC 60870-5-103 / Modbus RTU / DNP3.0 RTU, RS485, Terminals
- X104** – IRIG-B00X, incl. System Contact (Supervision Contact)

MRA4-2E1BKA

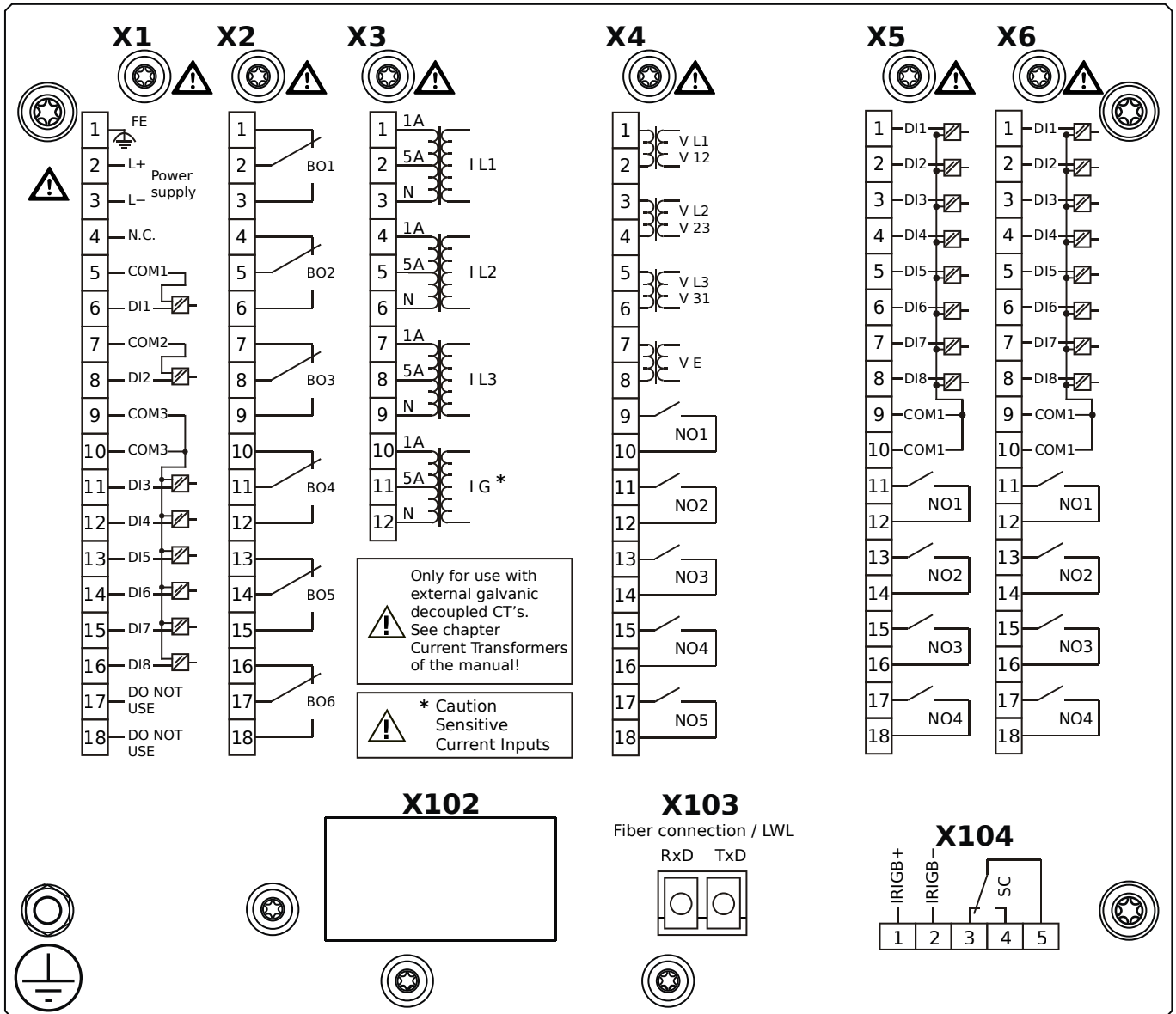

Housing B2, small display, 19" rack mounting

- X1** – DI8-X1: Wide-range power supply unit, incl. 2 non-grouped digital inputs and 6 grouped digital inputs
- X2** – OR6: Assembly Group with 6 Output Relays (Changeover / Form C)
- X3** – TIs: Standard phase current measuring card and sensitive ground current measuring
- X4** – TU-OR5: Voltage measuring (0 ... 300 VAC) assembly group with 5 additional Output Relays (NO / Form A)
- X5** – DI8-OR4: Assembly Group with 8 Digital Inputs and 4 Output Relays (NO / Form A)
- X6** – DI8-OR4: Assembly Group with 8 Digital Inputs and 4 Output Relays (NO / Form A)
- X103** – IEC 61850 / Modbus TCP / DNP3.0 TCP/UDP, Fiber optics interface, LC Connector
- X104** – IRIG-B00X, incl. System Contact (Supervision Contact)

MRA4-2E1BKB

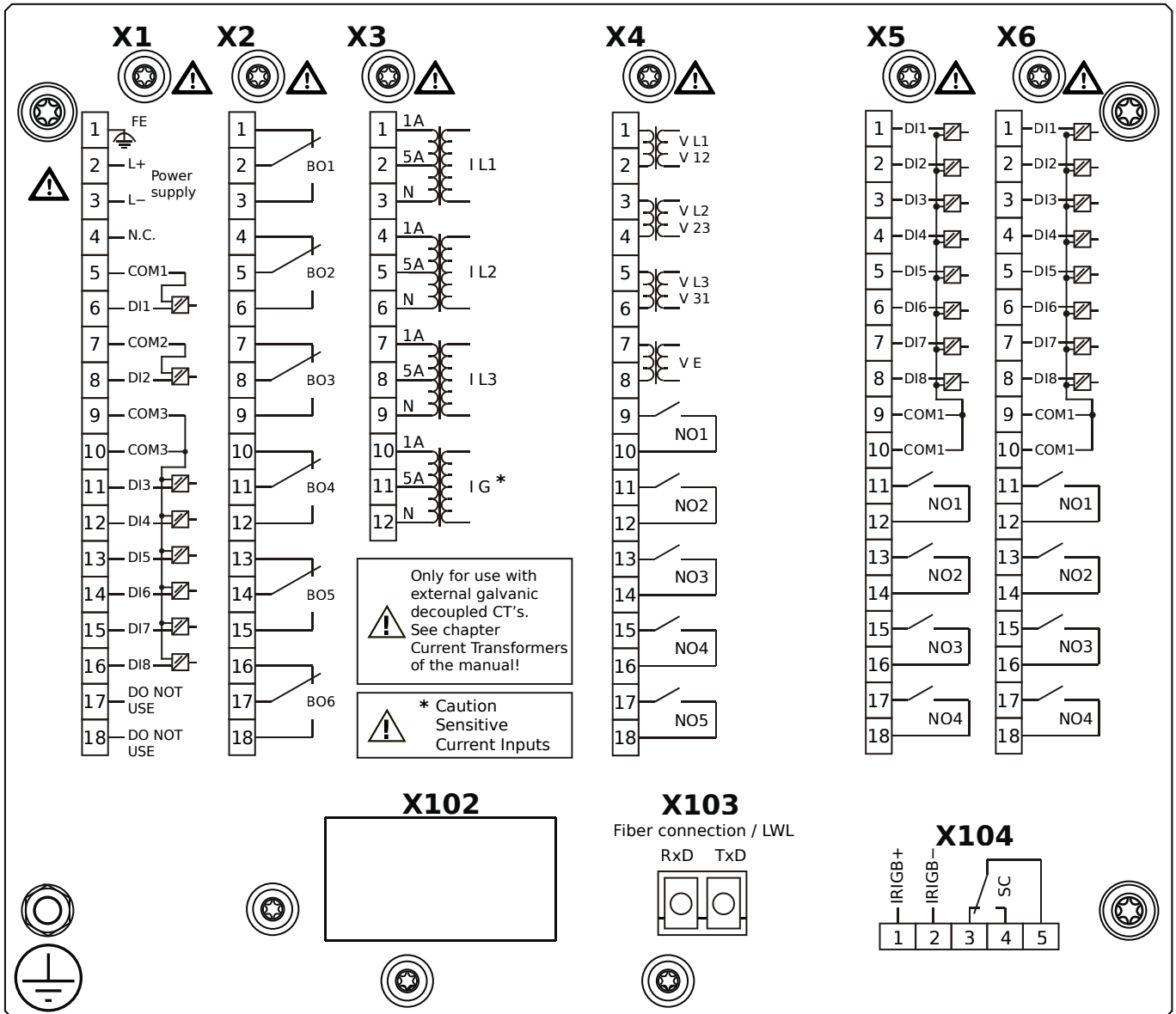

Housing B2, small display, 19" rack mounting

+ Conformal Coating (for installations in harsh environment)

- X1** – DI8-X1: Wide-range power supply unit, incl. 2 non-grouped digital inputs and 6 grouped digital inputs
- X2** – OR6: Assembly Group with 6 Output Relays (Changeover / Form C)
- X3** – TIs: Standard phase current measuring card and sensitive ground current measuring
- X4** – TU-OR5: Voltage measuring (0 ... 300 VAC) assembly group with 5 additional Output Relays (NO / Form A)
- X5** – DI8-OR4: Assembly Group with 8 Digital Inputs and 4 Output Relays (NO / Form A)
- X6** – DI8-OR4: Assembly Group with 8 Digital Inputs and 4 Output Relays (NO / Form A)
- X103** – IEC 61850 / Modbus TCP / DNP3.0 TCP/UDP, Fiber optics interface, LC Connector
- X104** – IRIG-B00X, incl. System Contact (Supervision Contact)

MRA4-2E1BLA

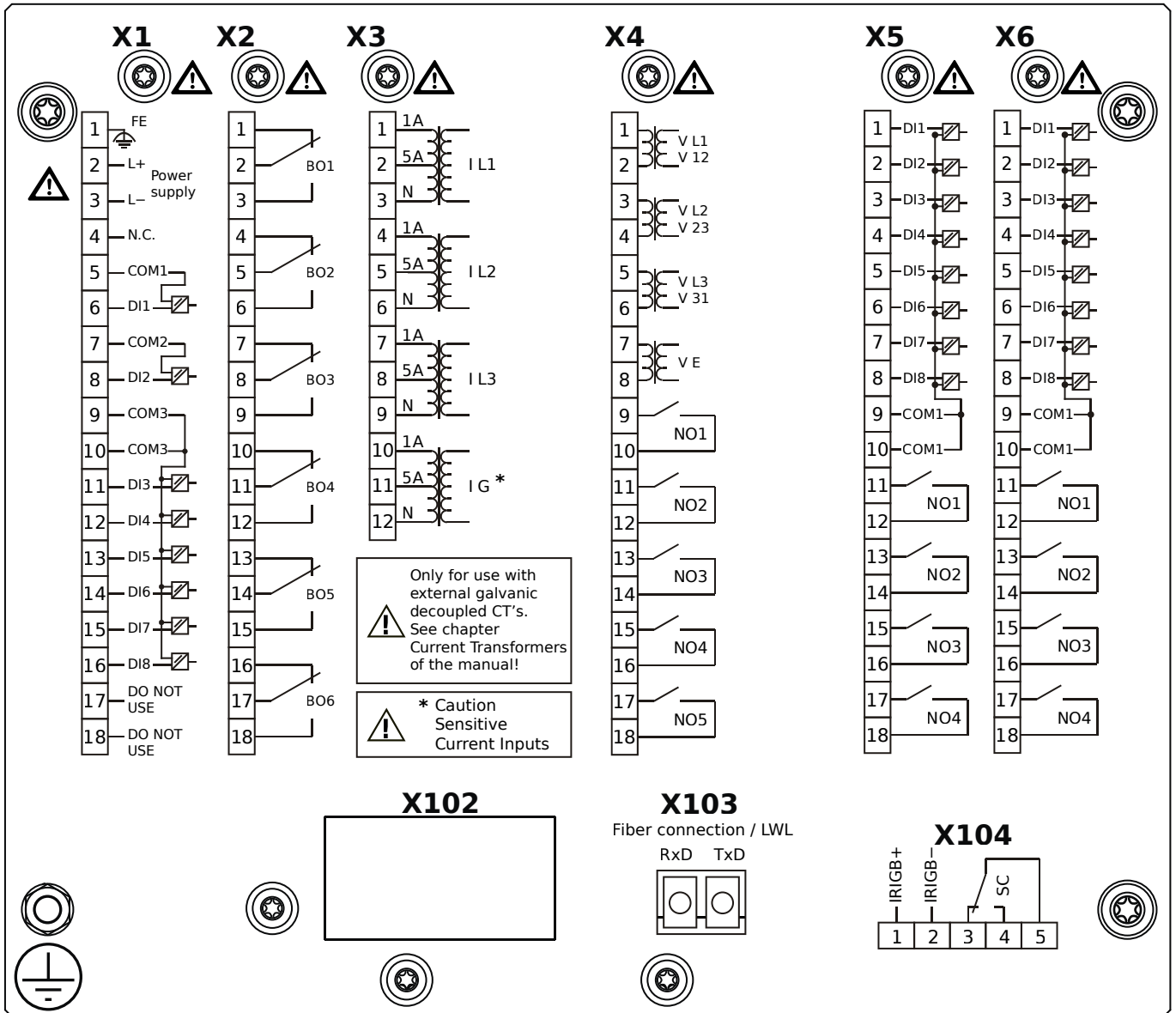

Housing B2, small display, 19" rack mounting

- X1** – DI8-X1: Wide-range power supply unit, incl. 2 non-grouped digital inputs and 6 grouped digital inputs
- X2** – OR6: Assembly Group with 6 Output Relays (Changeover / Form C)
- X3** – TIs: Standard phase current measuring card and sensitive ground current measuring
- X4** – TU-OR5: Voltage measuring (0 ... 300 VAC) assembly group with 5 additional Output Relays (NO / Form A)
- X5** – DI8-OR4: Assembly Group with 8 Digital Inputs and 4 Output Relays (NO / Form A)
- X6** – DI8-OR4: Assembly Group with 8 Digital Inputs and 4 Output Relays (NO / Form A)
- X103** – Modbus TCP / DNP3.0 TCP/UDP, Fiber optics interface, LC Connector
- X104** – IRIG-B00X, incl. System Contact (Supervision Contact)

MRA4-2E1BLB

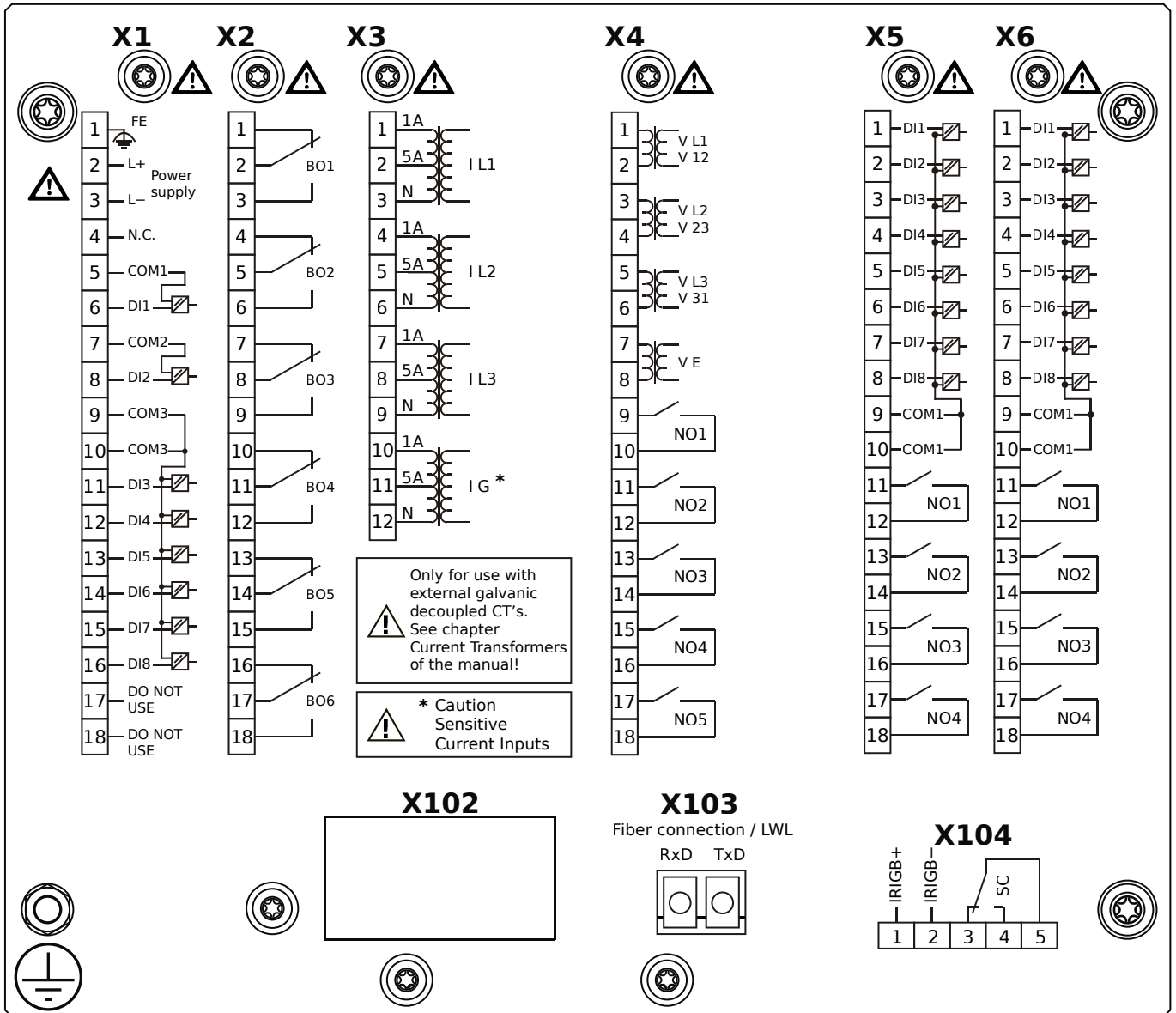

Housing B2, small display, 19" rack mounting

+ Conformal Coating (for installations in harsh environment)

- X1** – DI8-X1: Wide-range power supply unit, incl. 2 non-grouped digital inputs and 6 grouped digital inputs
- X2** – OR6: Assembly Group with 6 Output Relays (Changeover / Form C)
- X3** – TIs: Standard phase current measuring card and sensitive ground current measuring
- X4** – TU-OR5: Voltage measuring (0 ... 300 VAC) assembly group with 5 additional Output Relays (NO / Form A)
- X5** – DI8-OR4: Assembly Group with 8 Digital Inputs and 4 Output Relays (NO / Form A)
- X6** – DI8-OR4: Assembly Group with 8 Digital Inputs and 4 Output Relays (NO / Form A)
- X103** – Modbus TCP / DNP3.0 TCP/UDP, Fiber optics interface, LC Connector
- X104** – IRIG-B00X, incl. System Contact (Supervision Contact)

MRA4-2E1BTA

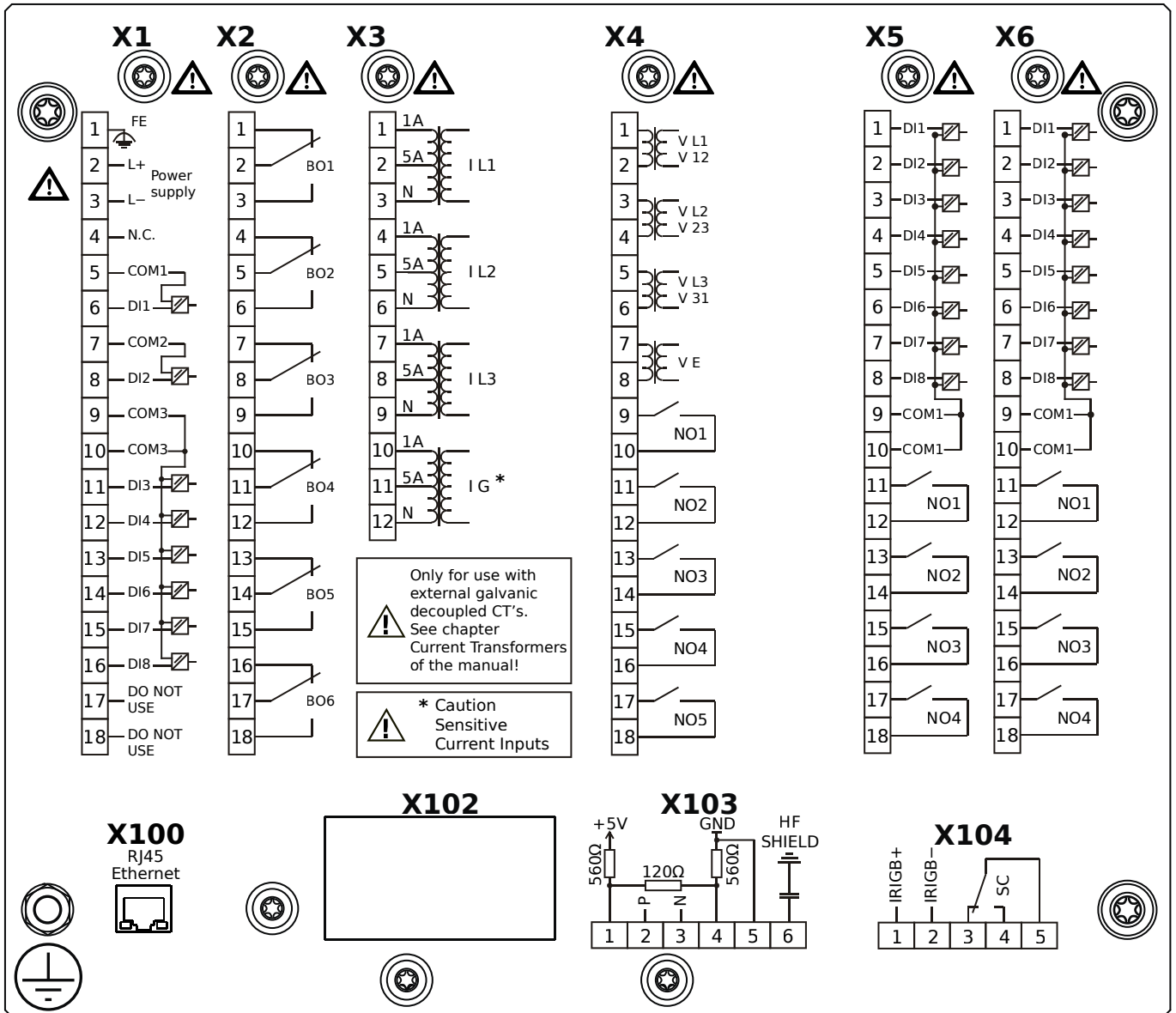

Housing B2, small display, 19" rack mounting

- X1** – DI8-X1: Wide-range power supply unit, incl. 2 non-grouped digital inputs and 6 grouped digital inputs
- X2** – OR6: Assembly Group with 6 Output Relays (Changeover / Form C)
- X3** – TIs: Standard phase current measuring card and sensitive ground current measuring
- X4** – TU-OR5: Voltage measuring (0 ... 300 VAC) assembly group with 5 additional Output Relays (NO / Form A)
- X5** – DI8-OR4: Assembly Group with 8 Digital Inputs and 4 Output Relays (NO / Form A)
- X6** – DI8-OR4: Assembly Group with 8 Digital Inputs and 4 Output Relays (NO / Form A)
- X100** – IEC 61850 / Modbus TCP / DNP3.0 TCP/UDP, Ethernet interface, 100 Mbit/s, RJ45 (BASE100-FX)
- X103** – IEC 60870-5-103 / Modbus RTU / DNP3.0 RTU, RS485, Terminals
- X104** – IRIG-B00X, incl. System Contact (Supervision Contact)

MRA4-2E1BTB

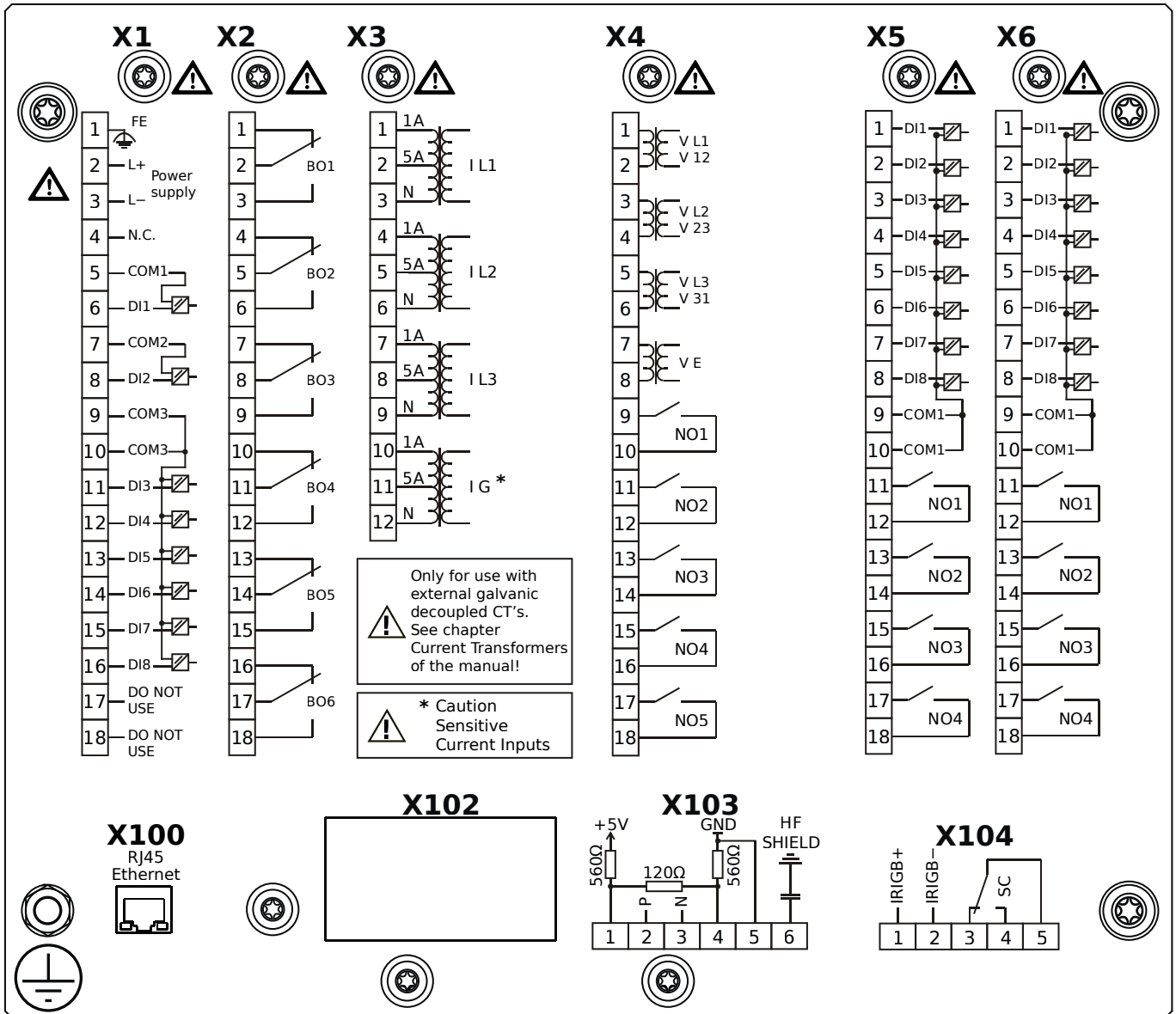

Housing B2, small display, 19" rack mounting

+ Conformal Coating (for installations in harsh environment)

- X1** – DI8-X1: Wide-range power supply unit, incl. 2 non-grouped digital inputs and 6 grouped digital inputs
- X2** – OR6: Assembly Group with 6 Output Relays (Changeover / Form C)
- X3** – TIs: Standard phase current measuring card and sensitive ground current measuring
- X4** – TU-OR5: Voltage measuring (0 ... 300 VAC) assembly group with 5 additional Output Relays (NO / Form A)
- X5** – DI8-OR4: Assembly Group with 8 Digital Inputs and 4 Output Relays (NO / Form A)
- X6** – DI8-OR4: Assembly Group with 8 Digital Inputs and 4 Output Relays (NO / Form A)
- X100** – IEC 61850 / Modbus TCP / DNP3.0 TCP/UDP, Ethernet interface, 100 Mbit/s, RJ45 (BASE100-FX)
- X103** – IEC 60870-5-103 / Modbus RTU / DNP3.0 RTU, RS485, Terminals
- X104** – IRIG-B00X, incl. System Contact (Supervision Contact)

MRA4-2F0AAA

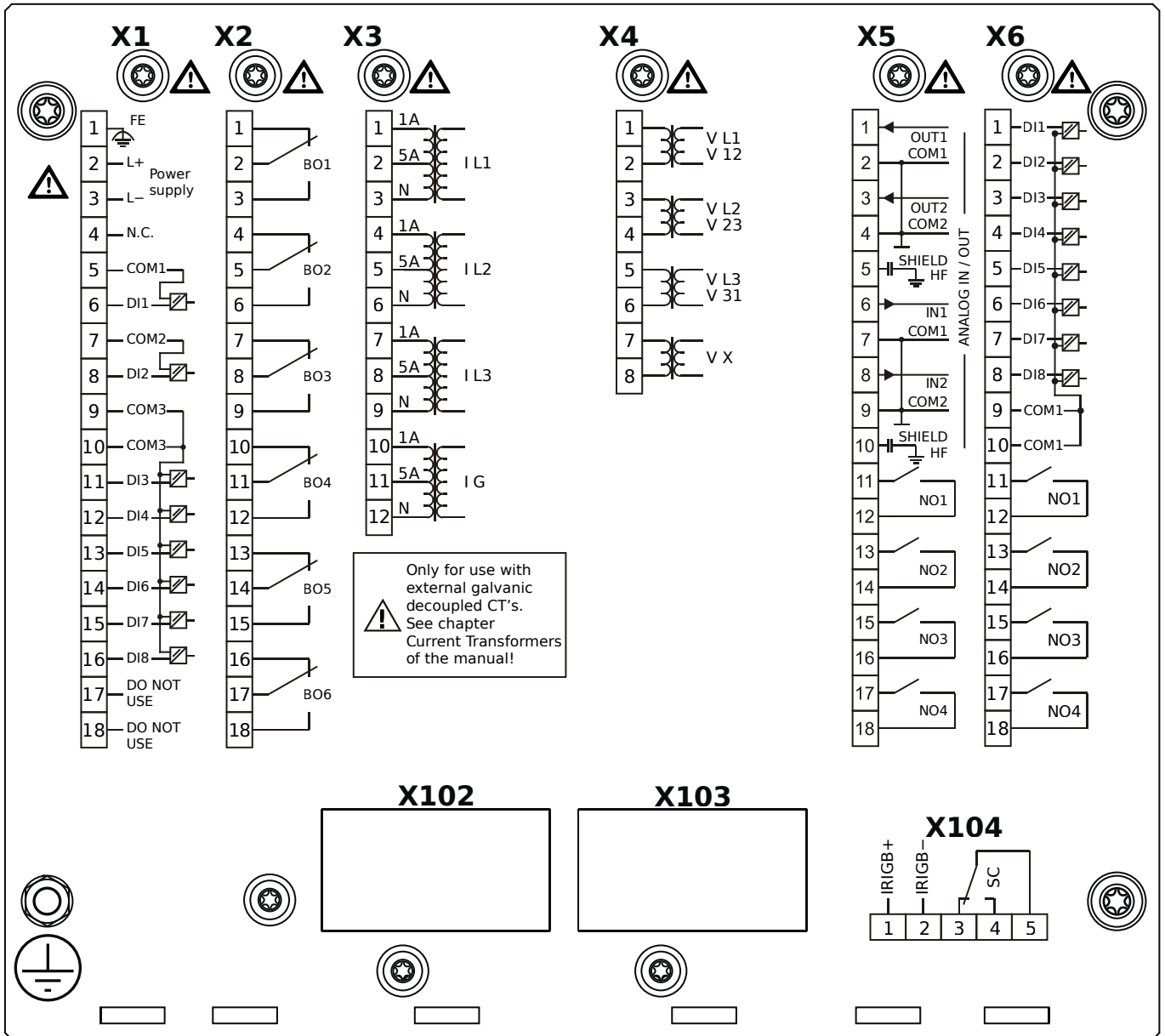

Housing B2, small display, door mounting

- X1** – DI8-X1: Wide-range power supply unit, incl. 2 non-grouped digital inputs and 6 grouped digital inputs
- X2** – OR6: Assembly Group with 6 Output Relays (Changeover / Form C)
- X3** – TI: Standard current measuring card
- X4** – TU: Card with 4 voltage transformer measuring inputs (0 ... 800 VAC, under UL: 0 ... 600 VAC)
- X5** – AnIO2-OR4: Assembly Group with 2 Analog Inputs, 2 Analog Outputs and 4 Output Relays
- X6** – DI8-OR4: Assembly Group with 8 Digital Inputs and 4 Output Relays (NO / Form A)
- X104** – IRIG-B00X, incl. System Contact (Supervision Contact)

MRA4-2F0AAB

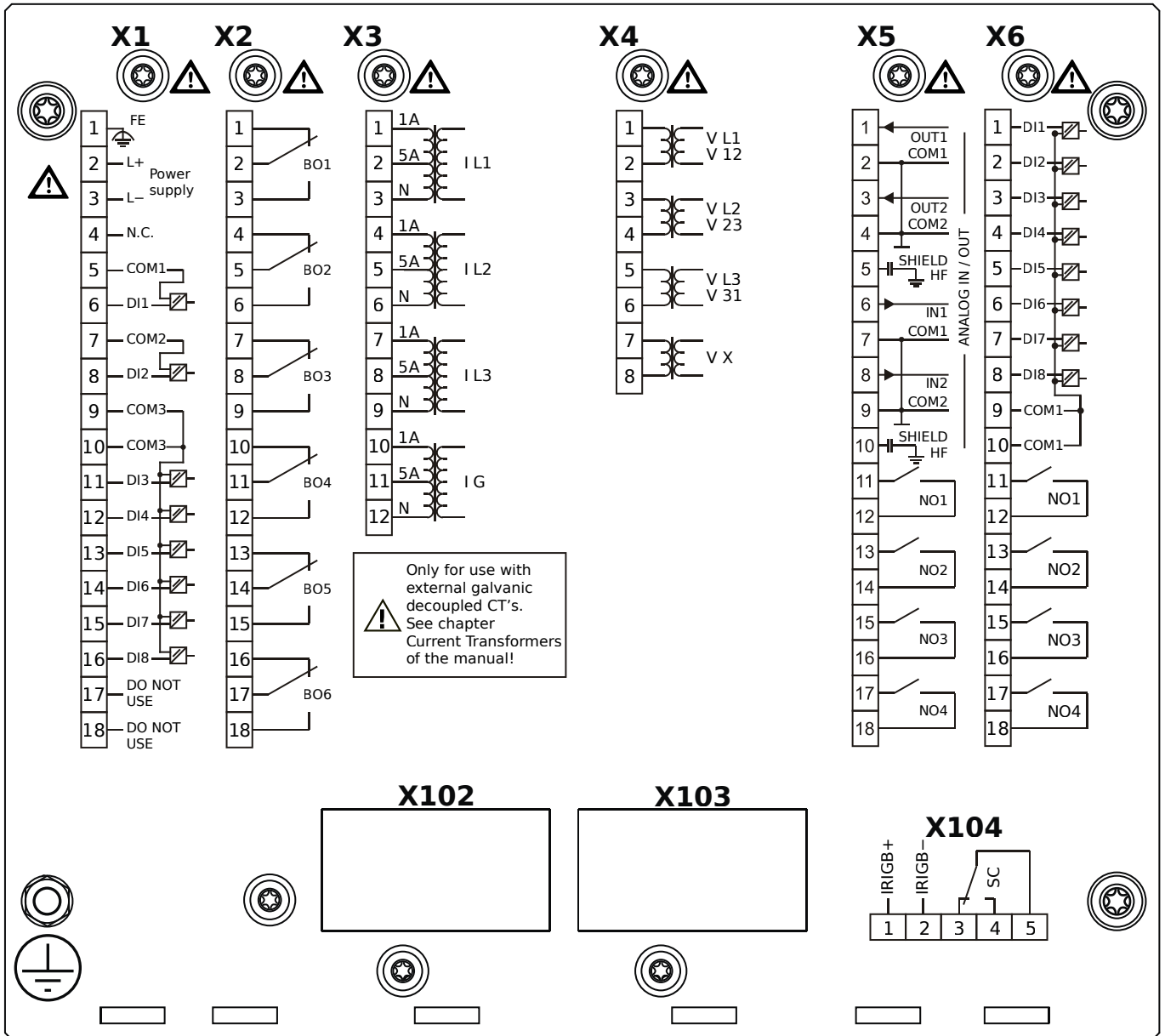

Housing B2, small display, door mounting

- + Conformal Coating (for installations in harsh environment)
- X1** – DI8-X1: Wide-range power supply unit, incl. 2 non-grouped digital inputs and 6 grouped digital inputs
- X2** – OR6: Assembly Group with 6 Output Relays (Changeover / Form C)
- X3** – TI: Standard current measuring card
- X4** – TU: Card with 4 voltage transformer measuring inputs (0 ... 800 VAC, under UL: 0 ... 600 VAC)
- X5** – AnIO2-OR4: Assembly Group with 2 Analog Inputs, 2 Analog Outputs and 4 Output Relays
- X6** – DI8-OR4: Assembly Group with 8 Digital Inputs and 4 Output Relays (NO / Form A)
- X104** – IRIG-B00X, incl. System Contact (Supervision Contact)

MRA4-2F0ABA

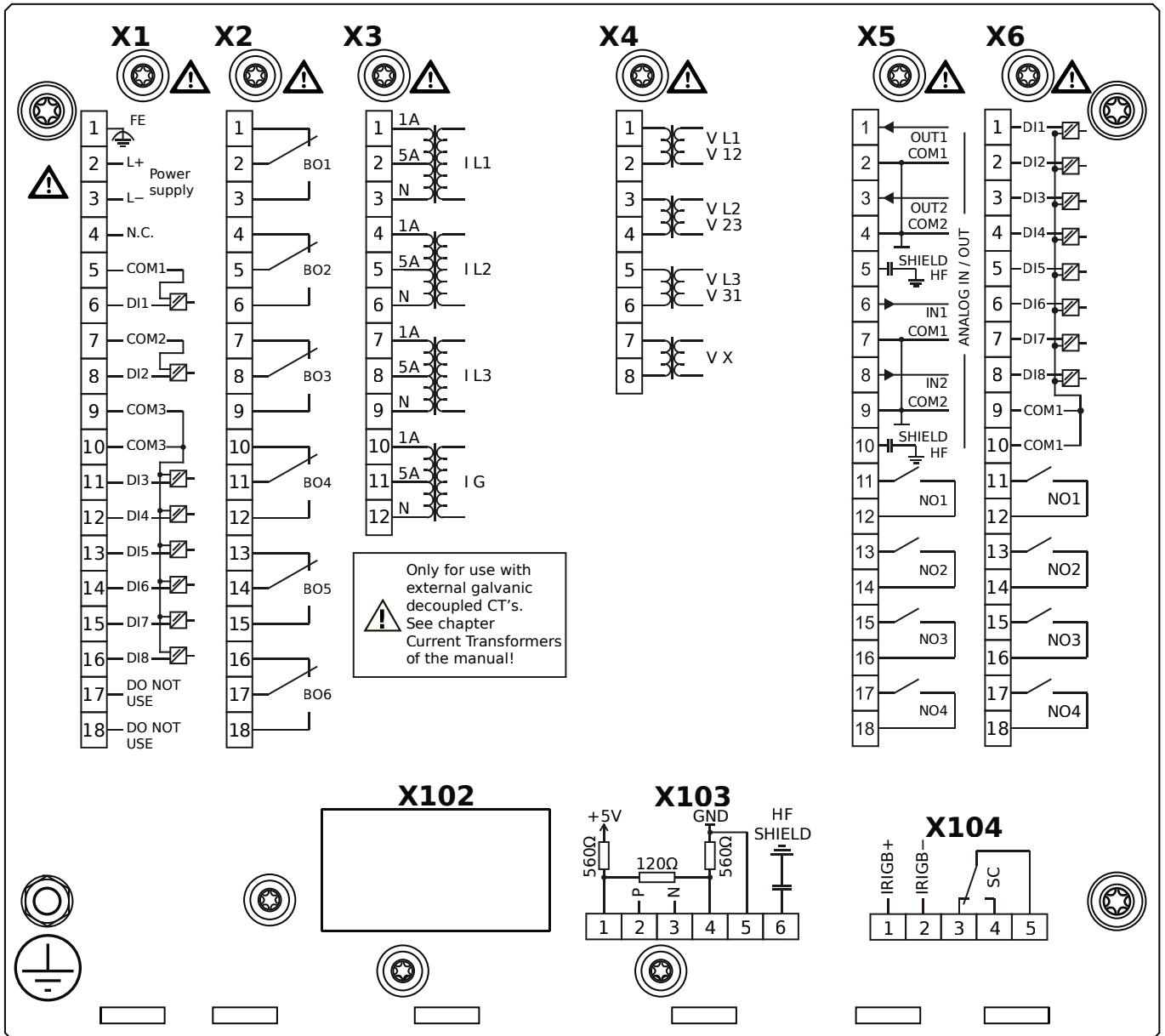

Housing B2, small display, door mounting

- X1** – DI8-X1: Wide-range power supply unit, incl. 2 non-grouped digital inputs and 6 grouped digital inputs
- X2** – OR6: Assembly Group with 6 Output Relays (Changeover / Form C)
- X3** – TI: Standard current measuring card
- X4** – TU: Card with 4 voltage transformer measuring inputs (0 ... 800 VAC, under UL: 0 ... 600 VAC)
- X5** – AnIO2-OR4: Assembly Group with 2 Analog Inputs, 2 Analog Outputs and 4 Output Relays
- X6** – DI8-OR4: Assembly Group with 8 Digital Inputs and 4 Output Relays (NO / Form A)
- X103** – Modbus RTU / IEC 60870-5-103 / DNP3.0 RTU, RS485, Terminals
- X104** – IRIG-B00X, incl. System Contact (Supervision Contact)

MRA4-2F0ABB

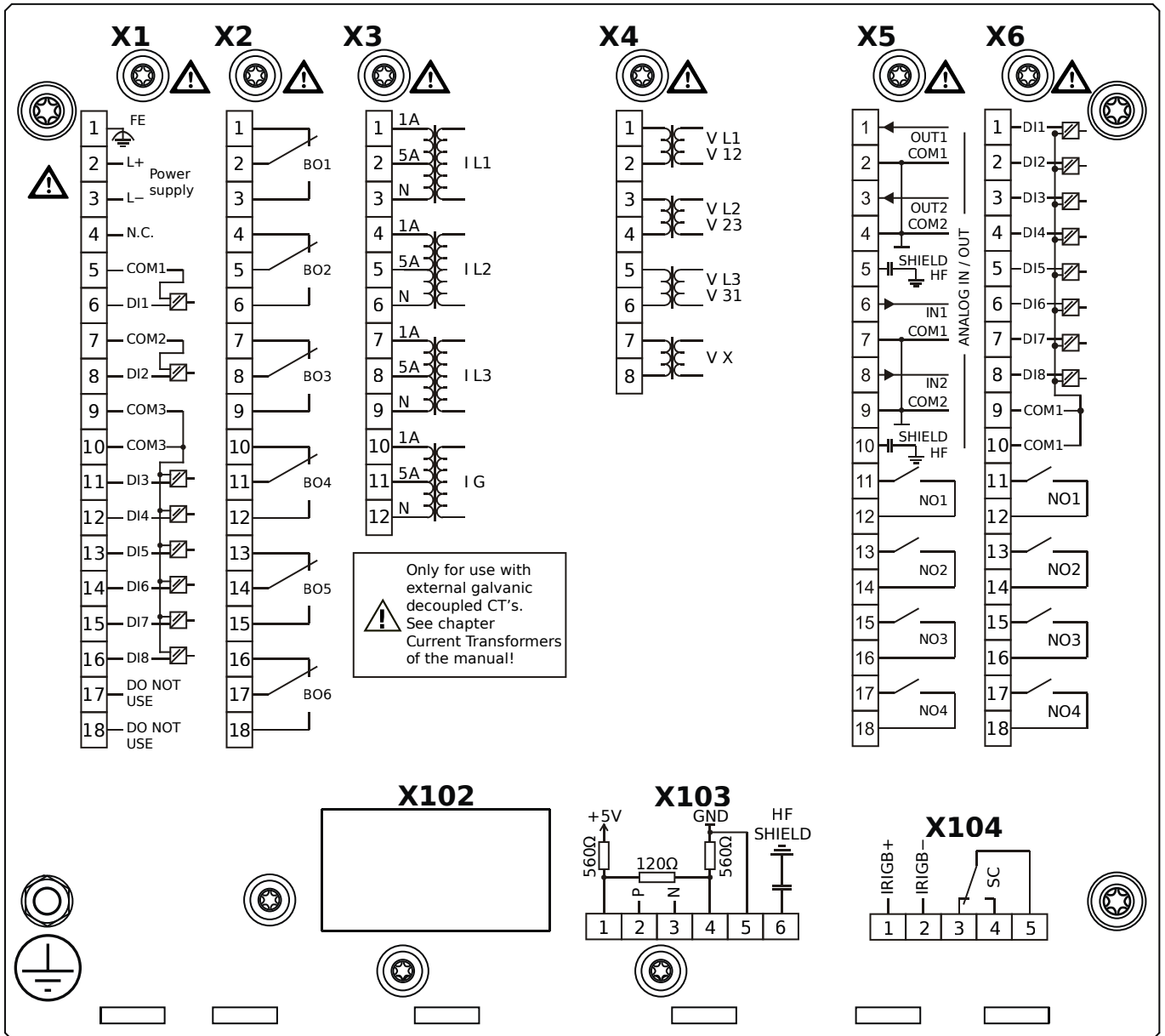

Housing B2, small display, door mounting

+ Conformal Coating (for installations in harsh environment)

- X1** – DI8-X1: Wide-range power supply unit, incl. 2 non-grouped digital inputs and 6 grouped digital inputs
- X2** – OR6: Assembly Group with 6 Output Relays (Changeover / Form C)
- X3** – TI: Standard current measuring card
- X4** – TU: Card with 4 voltage transformer measuring inputs (0 ... 800 VAC, under UL: 0 ... 600 VAC)
- X5** – AnIO2-OR4: Assembly Group with 2 Analog Inputs, 2 Analog Outputs and 4 Output Relays
- X6** – DI8-OR4: Assembly Group with 8 Digital Inputs and 4 Output Relays (NO / Form A)
- X103** – Modbus RTU / IEC 60870-5-103 / DNP3.0 RTU, RS485, Terminals
- X104** – IRIG-B00X, incl. System Contact (Supervision Contact)

MRA4-2F0ACA

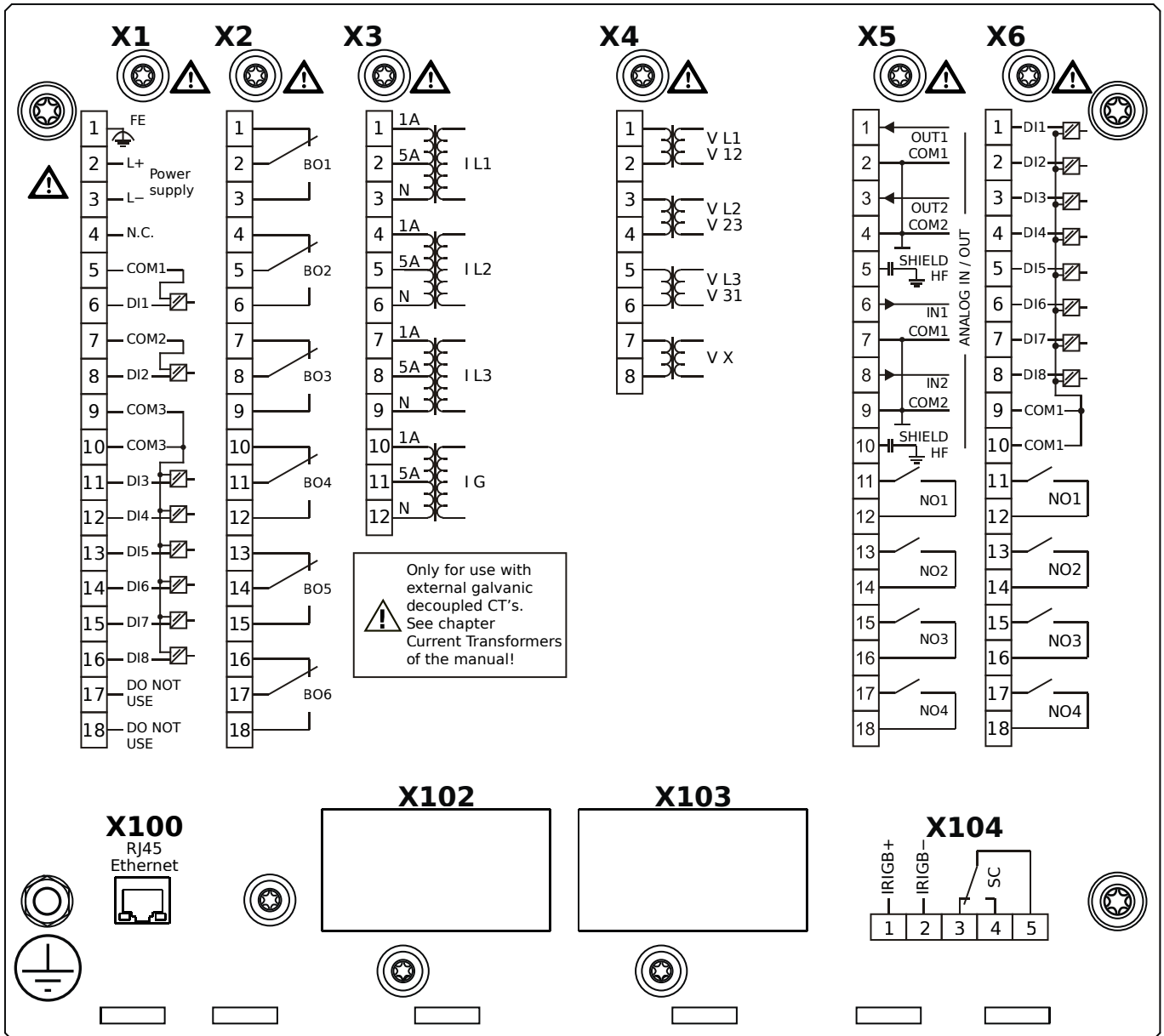

Housing B2, small display, door mounting

- X1** – DI8-X1: Wide-range power supply unit, incl. 2 non-grouped digital inputs and 6 grouped digital inputs
- X2** – OR6: Assembly Group with 6 Output Relays (Changeover / Form C)
- X3** – TI: Standard current measuring card
- X4** – TU: Card with 4 voltage transformer measuring inputs (0 ... 800 VAC, under UL: 0 ... 600 VAC)
- X5** – AnIO2-OR4: Assembly Group with 2 Analog Inputs, 2 Analog Outputs and 4 Output Relays
- X6** – DI8-OR4: Assembly Group with 8 Digital Inputs and 4 Output Relays (NO / Form A)
- X100** – Modbus TCP / DNP3.0 TCP/UDP, Ethernet interface, 100 Mbit/s, RJ45 (BASE100-FX)
- X104** – IRIG-B00X, incl. System Contact (Supervision Contact)

MRA4-2F0ACB

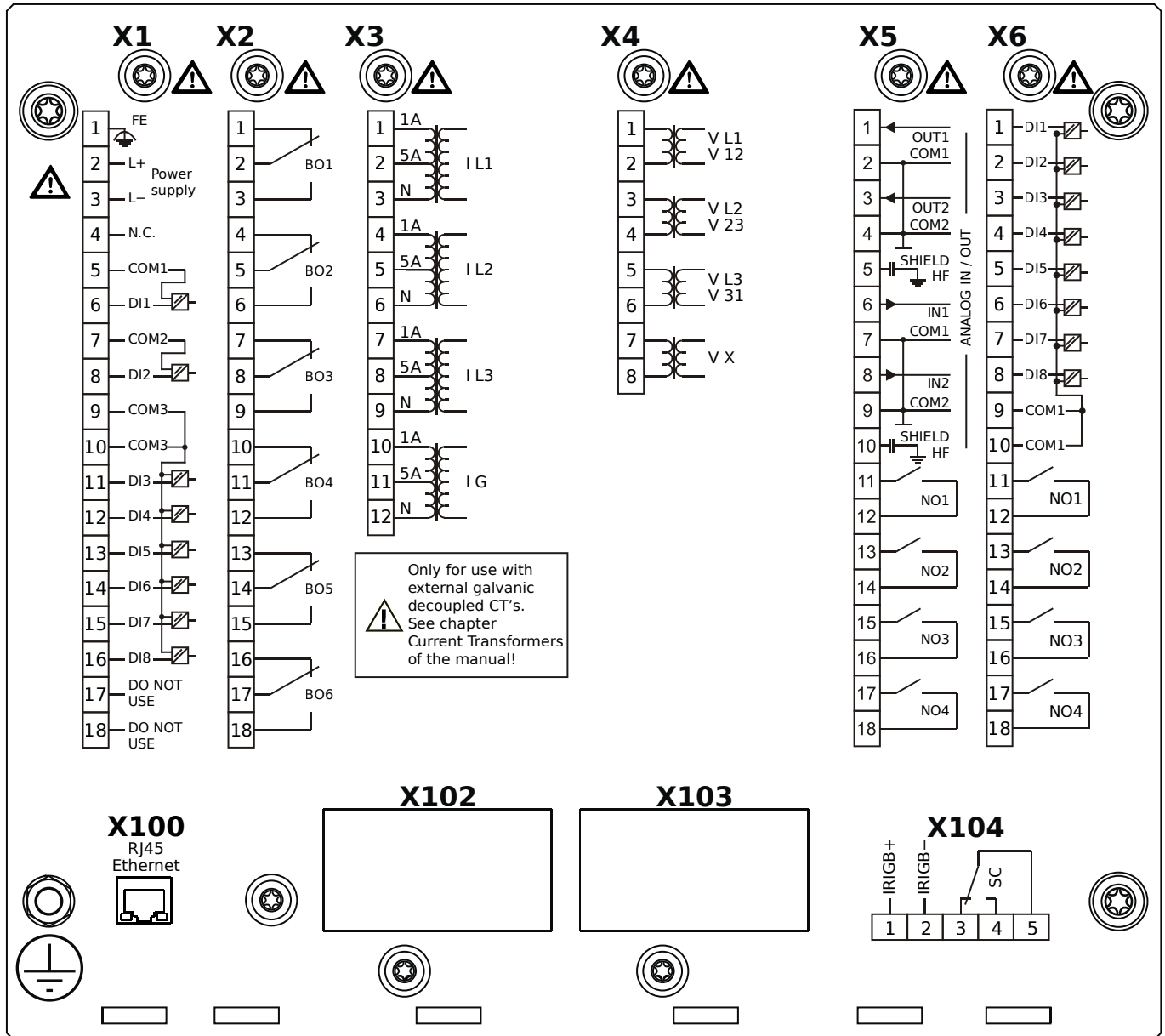

Housing B2, small display, door mounting

- + Conformal Coating (for installations in harsh environment)

- X1** – DI8-X1: Wide-range power supply unit, incl. 2 non-grouped digital inputs and 6 grouped digital inputs
- X2** – OR6: Assembly Group with 6 Output Relays (Changeover / Form C)
- X3** – TI: Standard current measuring card
- X4** – TU: Card with 4 voltage transformer measuring inputs (0 ... 800 VAC, under UL: 0 ... 600 VAC)
- X5** – AnIO2-OR4: Assembly Group with 2 Analog Inputs, 2 Analog Outputs and 4 Output Relays
- X6** – DI8-OR4: Assembly Group with 8 Digital Inputs and 4 Output Relays (NO / Form A)
- X100** – Modbus TCP / DNP3.0 TCP/UDP, Ethernet interface, 100 Mbit/s, RJ45 (BASE100-FX)
- X104** – IRIG-B00X, incl. System Contact (Supervision Contact)

MRA4-2F0ADA

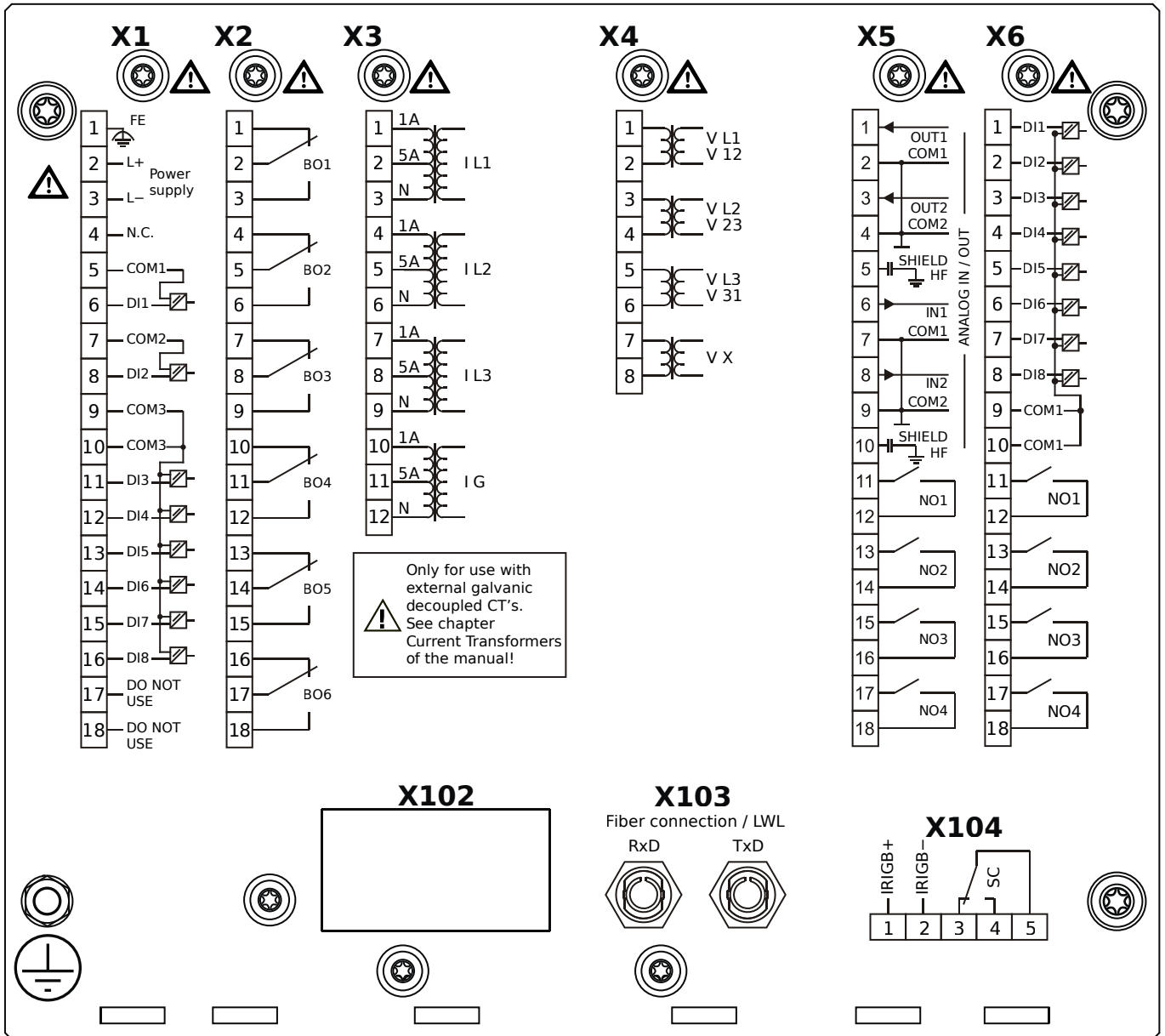

Housing B2, small display, door mounting

- X1** – DI8-X1: Wide-range power supply unit, incl. 2 non-grouped digital inputs and 6 grouped digital inputs
- X2** – OR6: Assembly Group with 6 Output Relays (Changeover / Form C)
- X3** – TI: Standard current measuring card
- X4** – TU: Card with 4 voltage transformer measuring inputs (0 ... 800 VAC, under UL: 0 ... 600 VAC)
- X5** – AnIO2-OR4: Assembly Group with 2 Analog Inputs, 2 Analog Outputs and 4 Output Relays
- X6** – DI8-OR4: Assembly Group with 8 Digital Inputs and 4 Output Relays (NO / Form A)
- X103** – Profibus-DP, Fiber optics interface, ST Connector
- X104** – IRIG-B00X, incl. System Contact (Supervision Contact)

MRA4-2F0ADB

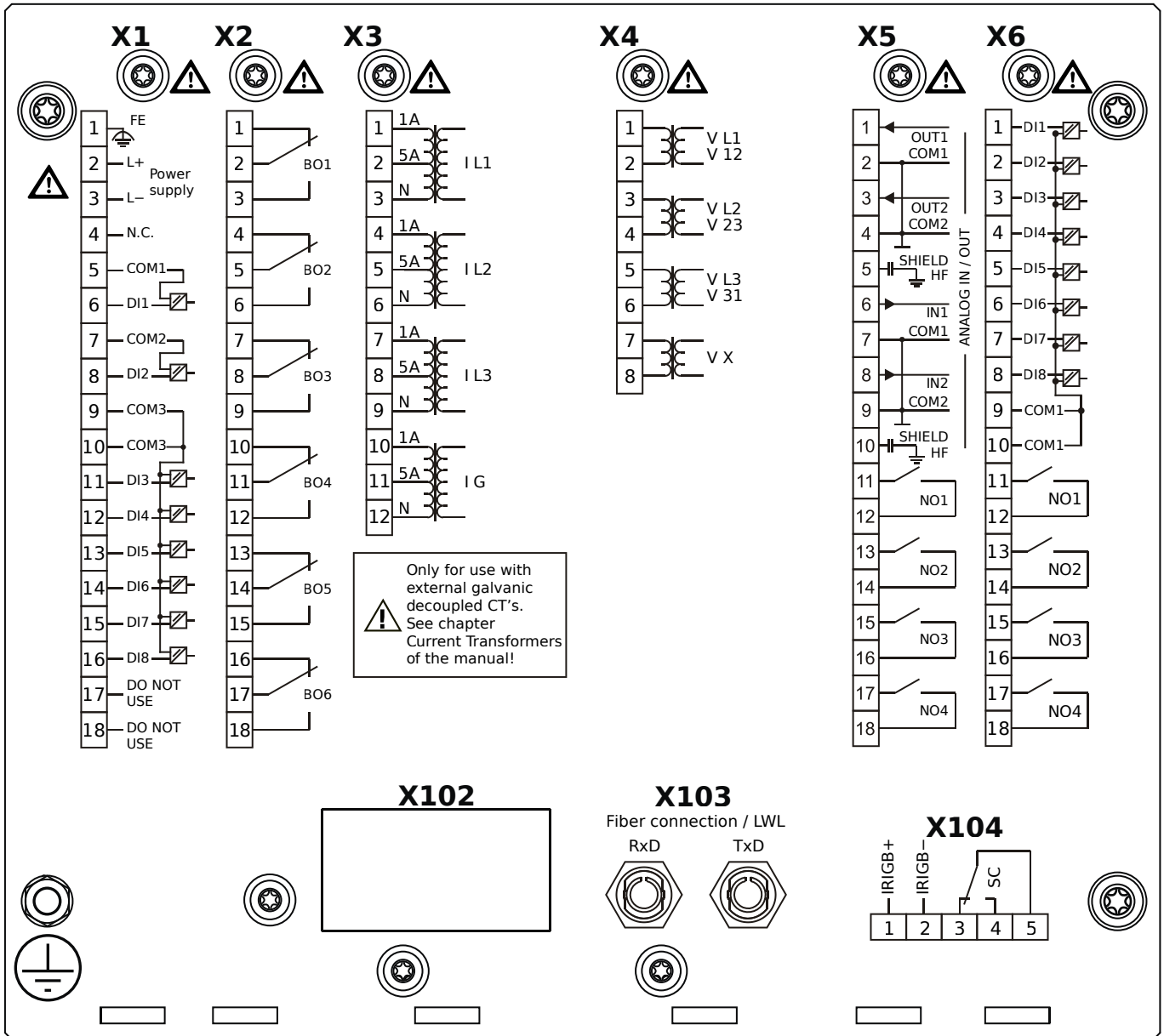

Housing B2, small display, door mounting

+ Conformal Coating (for installations in harsh environment)

- X1** – DI8-X1: Wide-range power supply unit, incl. 2 non-grouped digital inputs and 6 grouped digital inputs
- X2** – OR6: Assembly Group with 6 Output Relays (Changeover / Form C)
- X3** – TI: Standard current measuring card
- X4** – TU: Card with 4 voltage transformer measuring inputs (0 ... 800 VAC, under UL: 0 ... 600 VAC)
- X5** – AnIO2-OR4: Assembly Group with 2 Analog Inputs, 2 Analog Outputs and 4 Output Relays
- X6** – DI8-OR4: Assembly Group with 8 Digital Inputs and 4 Output Relays (NO / Form A)
- X103** – Profibus-DP, Fiber optics interface, ST Connector
- X104** – IRIG-B00X, incl. System Contact (Supervision Contact)

MRA4-2F0AEA

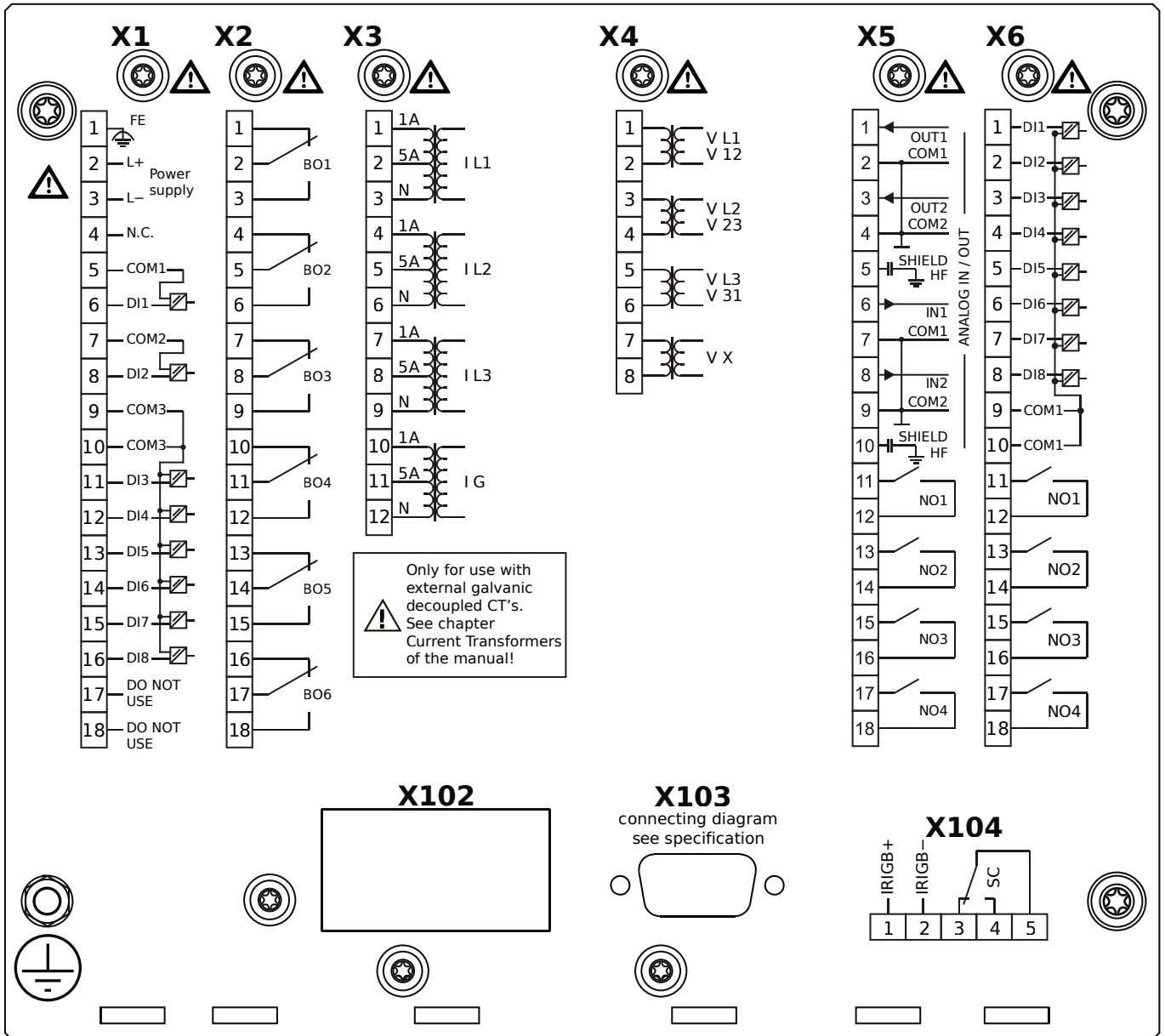

Housing B2, small display, door mounting

- X1** – DI8-X1: Wide-range power supply unit, incl. 2 non-grouped digital inputs and 6 grouped digital inputs
- X2** – OR6: Assembly Group with 6 Output Relays (Changeover / Form C)
- X3** – TI: Standard current measuring card
- X4** – TU: Card with 4 voltage transformer measuring inputs (0 ... 800 VAC, under UL: 0 ... 600 VAC)
- X5** – AnIO2-OR4: Assembly Group with 2 Analog Inputs, 2 Analog Outputs and 4 Output Relays
- X6** – DI8-OR4: Assembly Group with 8 Digital Inputs and 4 Output Relays (NO / Form A)
- X103** – Profibus-DP, RS485, D-SUB
- X104** – IRIG-B00X, incl. System Contact (Supervision Contact)

MRA4-2F0AEB

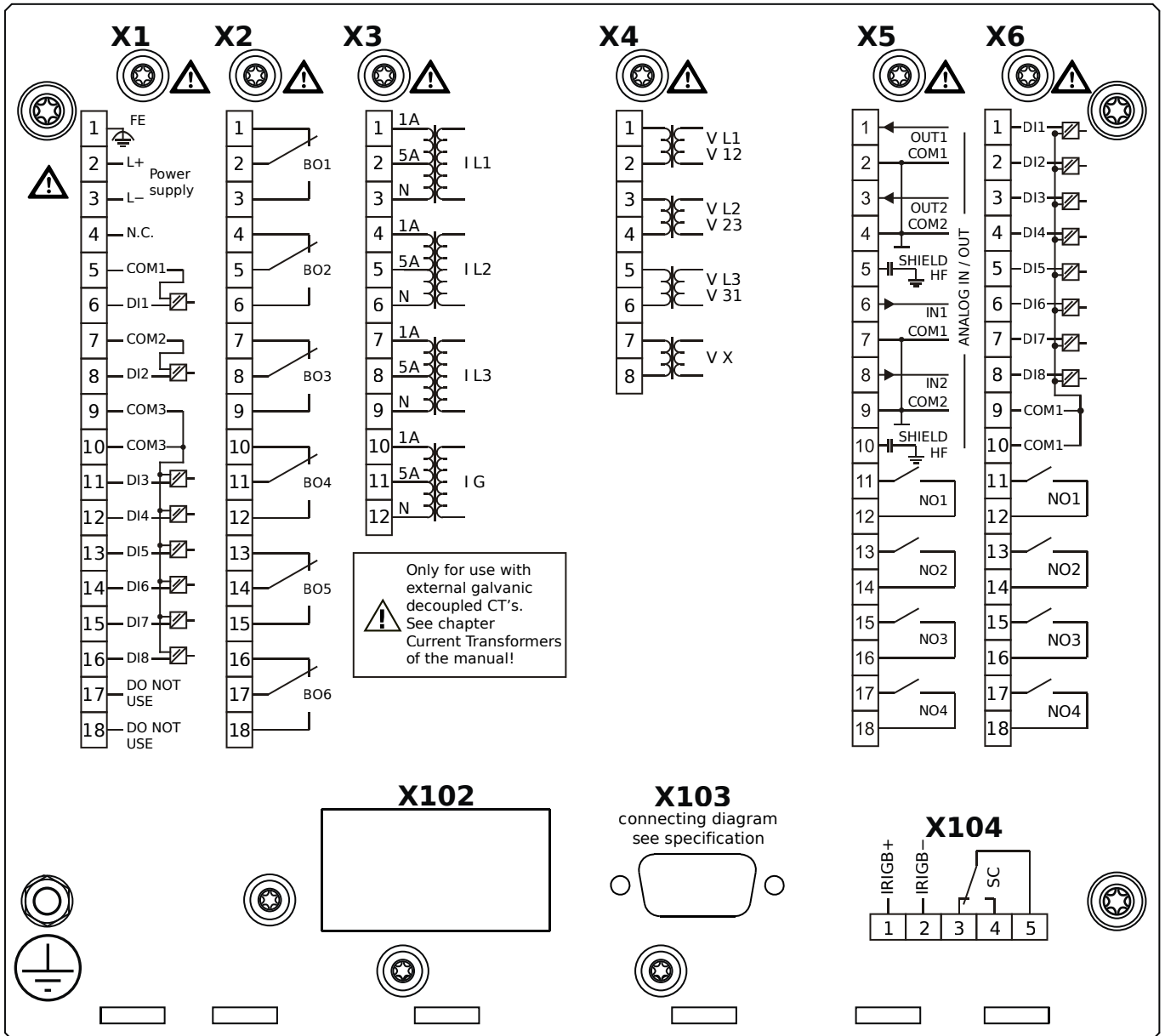

Housing B2, small display, door mounting

- + Conformal Coating (for installations in harsh environment)

- X1** – DI8-X1: Wide-range power supply unit, incl. 2 non-grouped digital inputs and 6 grouped digital inputs
- X2** – OR6: Assembly Group with 6 Output Relays (Changeover / Form C)
- X3** – TI: Standard current measuring card
- X4** – TU: Card with 4 voltage transformer measuring inputs (0 ... 800 VAC, under UL: 0 ... 600 VAC)
- X5** – AnIO2-OR4: Assembly Group with 2 Analog Inputs, 2 Analog Outputs and 4 Output Relays
- X6** – DI8-OR4: Assembly Group with 8 Digital Inputs and 4 Output Relays (NO / Form A)
- X103** – Profibus-DP, RS485, D-SUB
- X104** – IRIG-B00X, incl. System Contact (Supervision Contact)

MRA4-2F0AFA

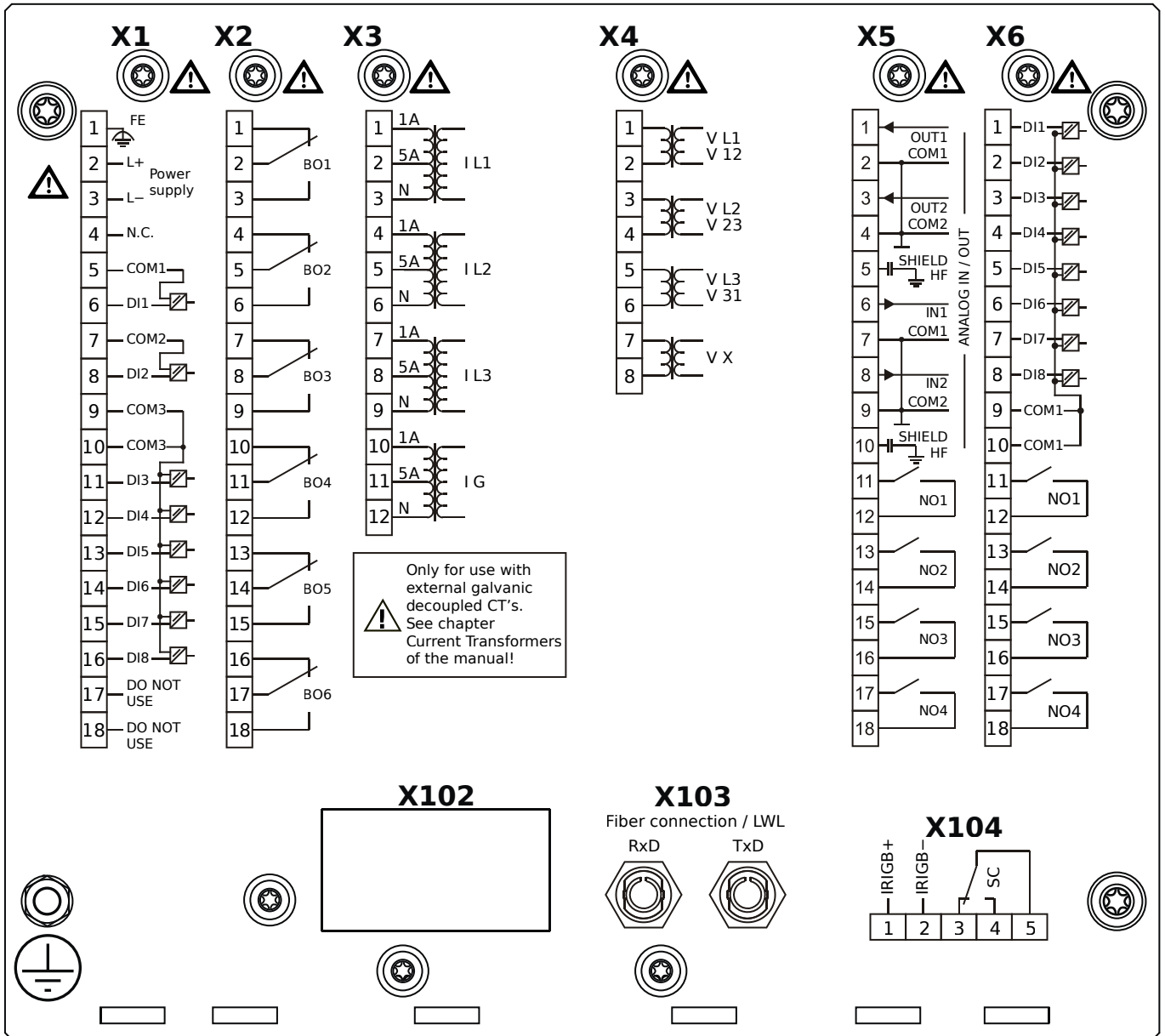

Housing B2, small display, door mounting

- X1** – DI8-X1: Wide-range power supply unit, incl. 2 non-grouped digital inputs and 6 grouped digital inputs
- X2** – OR6: Assembly Group with 6 Output Relays (Changeover / Form C)
- X3** – TI: Standard current measuring card
- X4** – TU: Card with 4 voltage transformer measuring inputs (0 ... 800 VAC, under UL: 0 ... 600 VAC)
- X5** – AnIO2-OR4: Assembly Group with 2 Analog Inputs, 2 Analog Outputs and 4 Output Relays
- X6** – DI8-OR4: Assembly Group with 8 Digital Inputs and 4 Output Relays (NO / Form A)
- X103** – Modbus RTU / IEC 60870-5-103 / DNP3.0 RTU, Fiber optics interface, ST Connector
- X104** – IRIG-B00X, incl. System Contact (Supervision Contact)

MRA4-2F0AFB

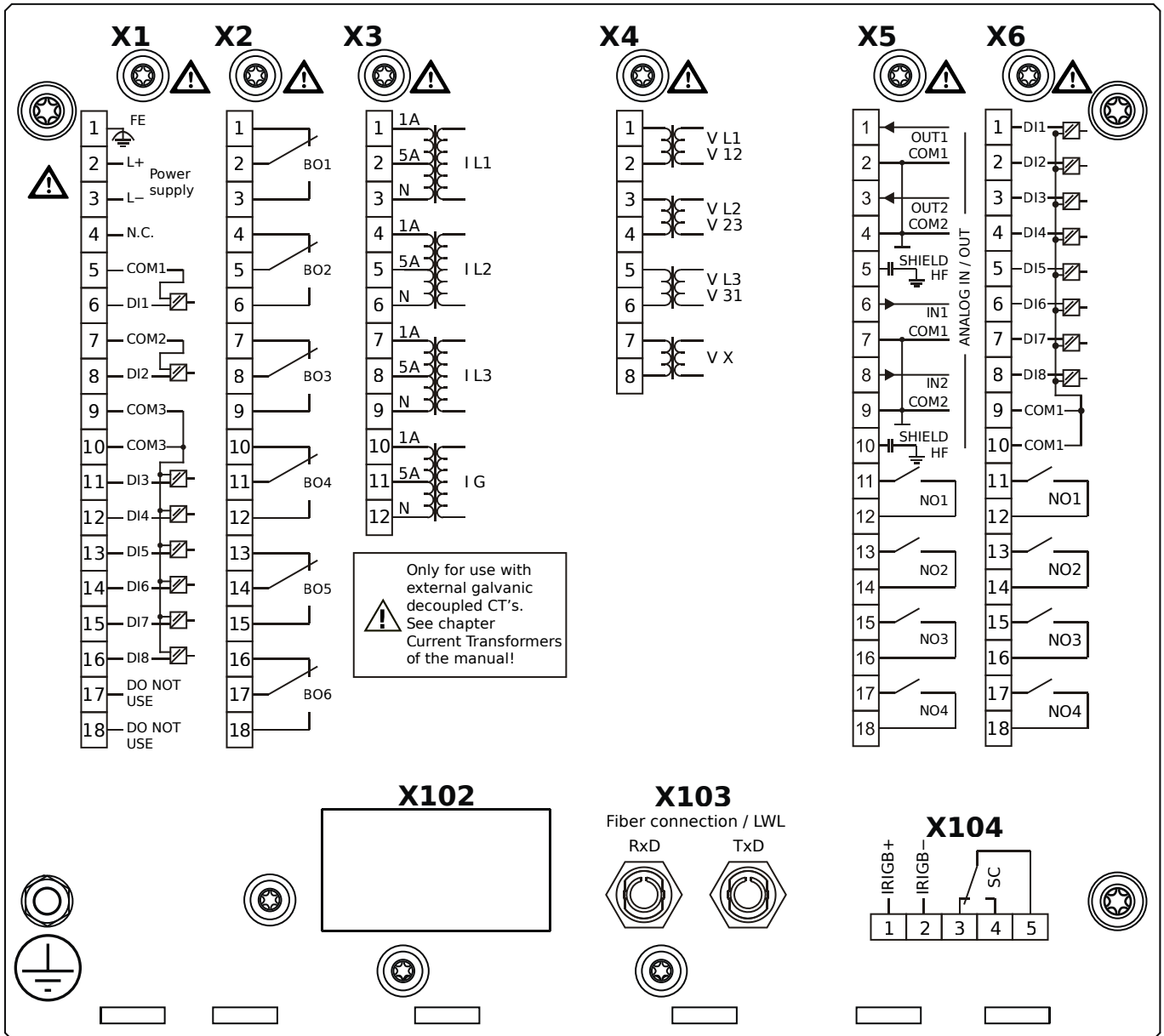

Housing B2, small display, door mounting

- + Conformal Coating (for installations in harsh environment)

- X1** – DI8-X1: Wide-range power supply unit, incl. 2 non-grouped digital inputs and 6 grouped digital inputs
- X2** – OR6: Assembly Group with 6 Output Relays (Changeover / Form C)
- X3** – TI: Standard current measuring card
- X4** – TU: Card with 4 voltage transformer measuring inputs (0 ... 800 VAC, under UL: 0 ... 600 VAC)
- X5** – AnIO2-OR4: Assembly Group with 2 Analog Inputs, 2 Analog Outputs and 4 Output Relays
- X6** – DI8-OR4: Assembly Group with 8 Digital Inputs and 4 Output Relays (NO / Form A)
- X103** – Modbus RTU / IEC 60870-5-103 / DNP3.0 RTU, Fiber optics interface, ST Connector
- X104** – IRIG-B00X, incl. System Contact (Supervision Contact)

MRA4-2F0AGA

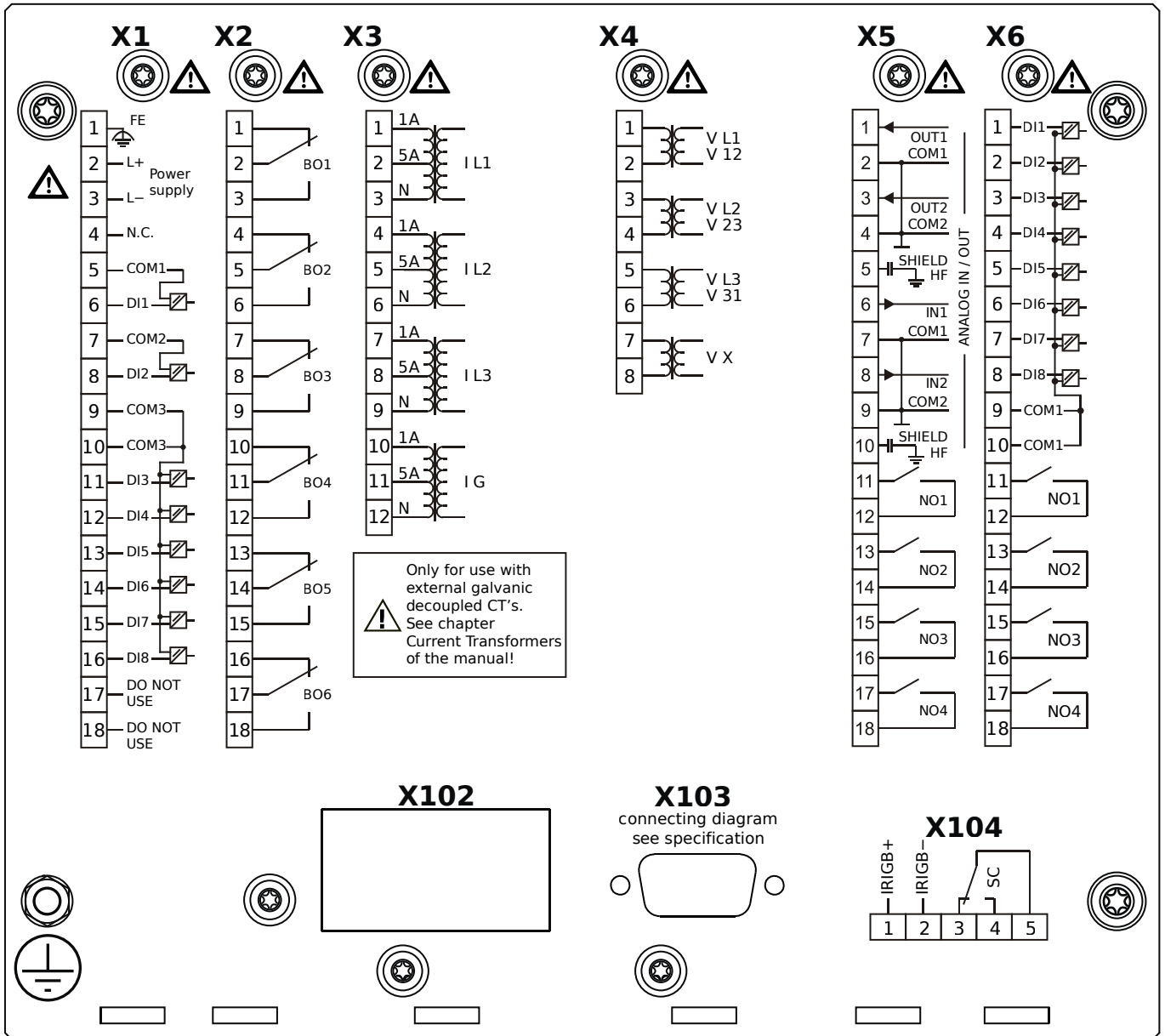

Housing B2, small display, door mounting

- X1** – DI8-X1: Wide-range power supply unit, incl. 2 non-grouped digital inputs and 6 grouped digital inputs
- X2** – OR6: Assembly Group with 6 Output Relays (Changeover / Form C)
- X3** – TI: Standard current measuring card
- X4** – TU: Card with 4 voltage transformer measuring inputs (0 ... 800 VAC, under UL: 0 ... 600 VAC)
- X5** – AnIO2-OR4: Assembly Group with 2 Analog Inputs, 2 Analog Outputs and 4 Output Relays
- X6** – DI8-OR4: Assembly Group with 8 Digital Inputs and 4 Output Relays (NO / Form A)
- X103** – Modbus RTU / IEC 60870-5-103 / DNP3.0 RTU, RS485, D-SUB
- X104** – IRIG-B00X, incl. System Contact (Supervision Contact)

MRA4-2F0AGB

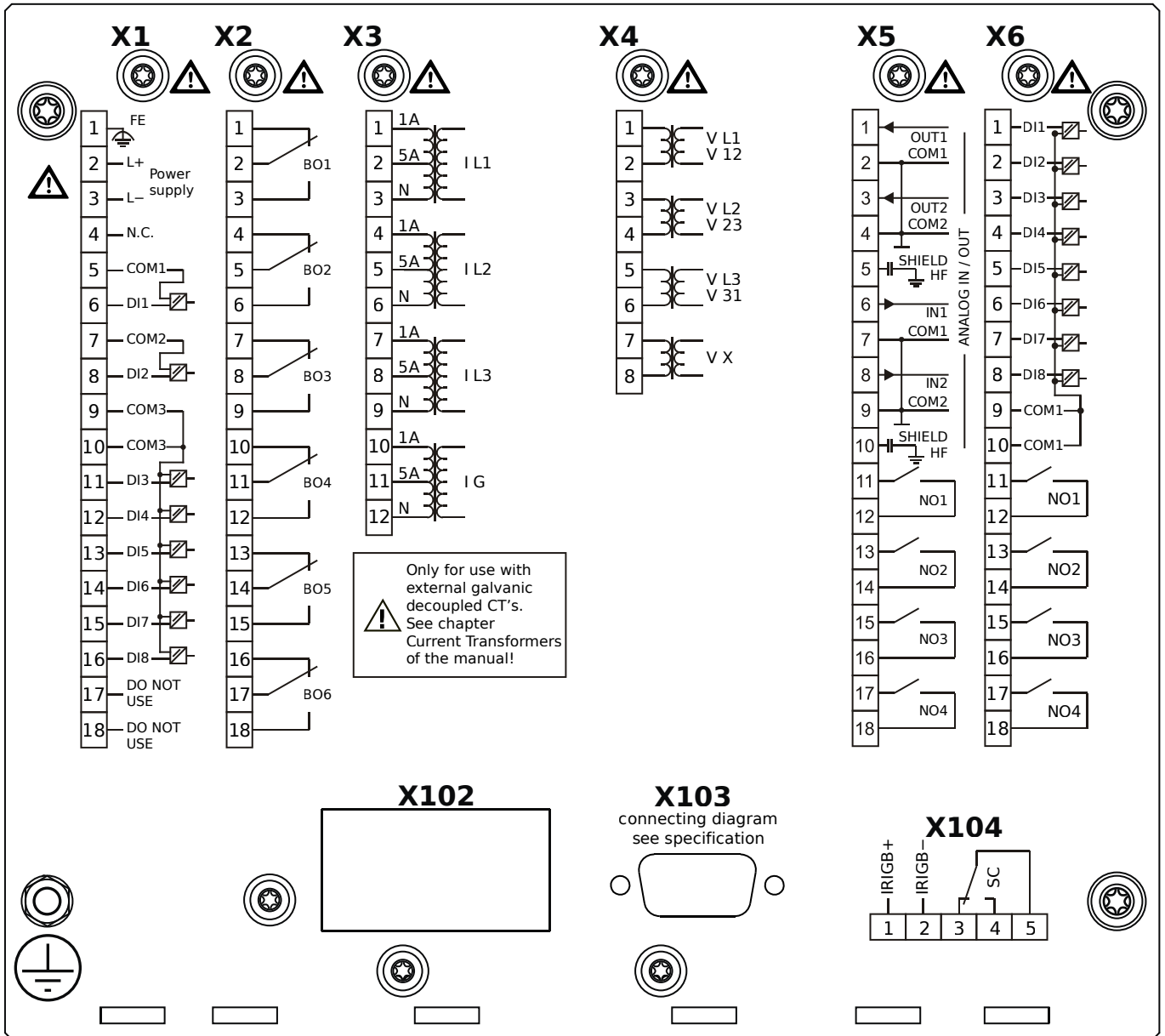

Housing B2, small display, door mounting

+ Conformal Coating (for installations in harsh environment)

- X1** – DI8-X1: Wide-range power supply unit, incl. 2 non-grouped digital inputs and 6 grouped digital inputs
- X2** – OR6: Assembly Group with 6 Output Relays (Changeover / Form C)
- X3** – TI: Standard current measuring card
- X4** – TU: Card with 4 voltage transformer measuring inputs (0 ... 800 VAC, under UL: 0 ... 600 VAC)
- X5** – AnIO2-OR4: Assembly Group with 2 Analog Inputs, 2 Analog Outputs and 4 Output Relays
- X6** – DI8-OR4: Assembly Group with 8 Digital Inputs and 4 Output Relays (NO / Form A)
- X103** – Modbus RTU / IEC 60870-5-103 / DNP3.0 RTU, RS485, D-SUB
- X104** – IRIG-B00X, incl. System Contact (Supervision Contact)

MRA4-2F0AHA

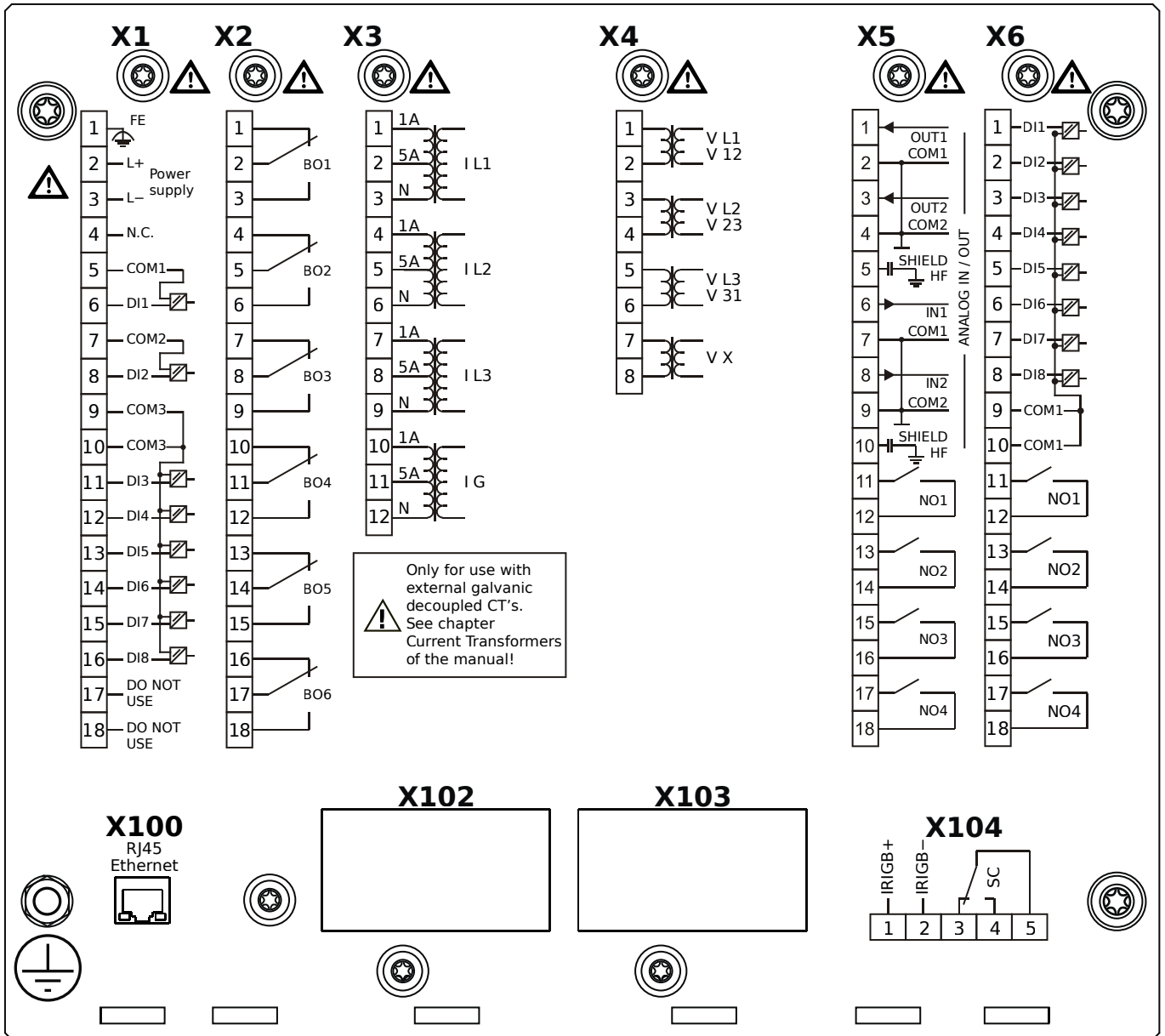

Housing B2, small display, door mounting

- X1** – DI8-X1: Wide-range power supply unit, incl. 2 non-grouped digital inputs and 6 grouped digital inputs
- X2** – OR6: Assembly Group with 6 Output Relays (Changeover / Form C)
- X3** – TI: Standard current measuring card
- X4** – TU: Card with 4 voltage transformer measuring inputs (0 ... 800 VAC, under UL: 0 ... 600 VAC)
- X5** – AnIO2-OR4: Assembly Group with 2 Analog Inputs, 2 Analog Outputs and 4 Output Relays
- X6** – DI8-OR4: Assembly Group with 8 Digital Inputs and 4 Output Relays (NO / Form A)
- X100** – IEC 61850 / Modbus TCP / DNP3.0 TCP/UDP, Ethernet interface, 100 Mbit/s, RJ45 (BASE100-FX)
- X104** – IRIG-B00X, incl. System Contact (Supervision Contact)

MRA4-2F0AHB

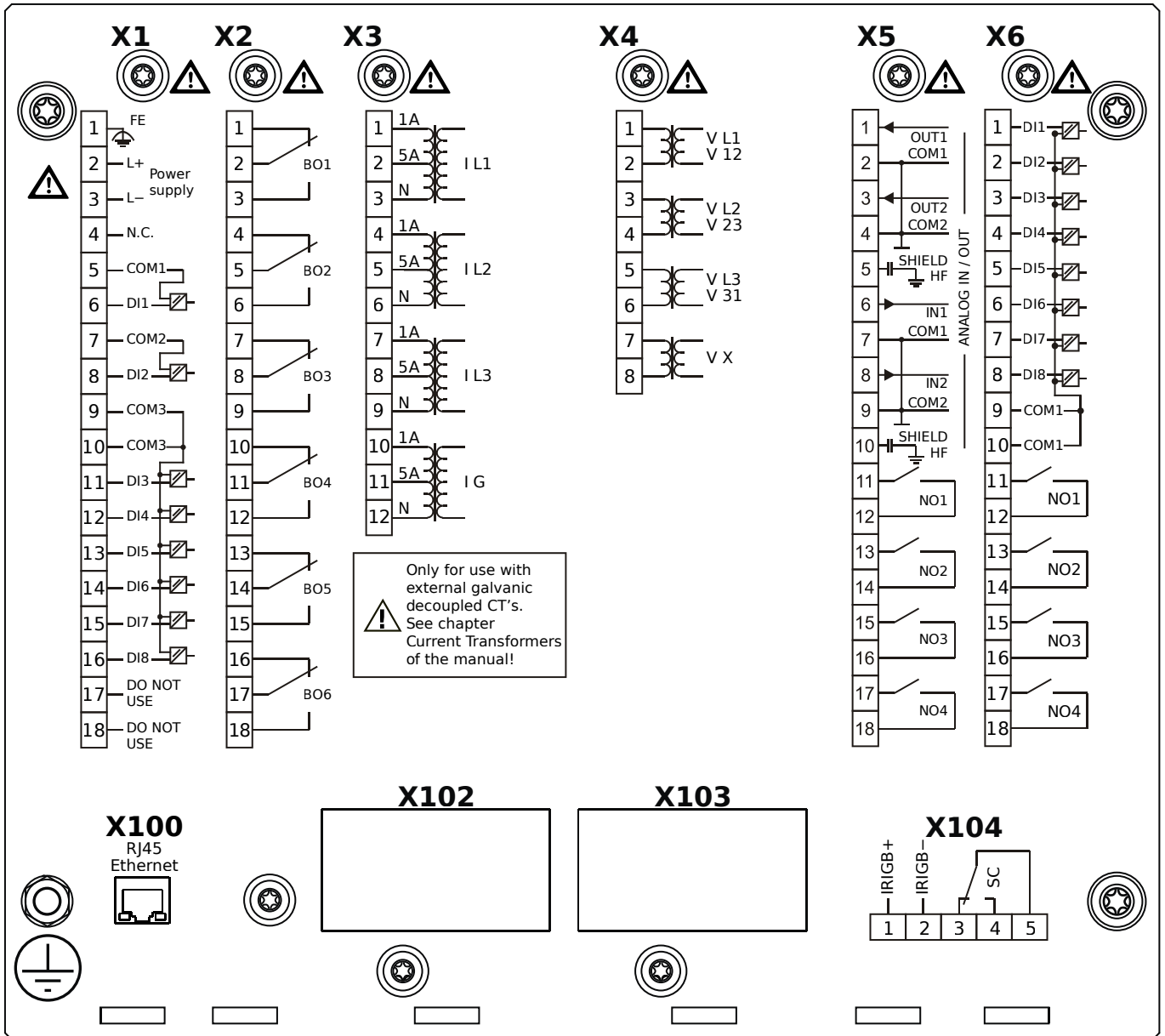

Housing B2, small display, door mounting

+ Conformal Coating (for installations in harsh environment)

- X1** – DI8-X1: Wide-range power supply unit, incl. 2 non-grouped digital inputs and 6 grouped digital inputs
- X2** – OR6: Assembly Group with 6 Output Relays (Changeover / Form C)
- X3** – TI: Standard current measuring card
- X4** – TU: Card with 4 voltage transformer measuring inputs (0 ... 800 VAC, under UL: 0 ... 600 VAC)
- X5** – AnIO2-OR4: Assembly Group with 2 Analog Inputs, 2 Analog Outputs and 4 Output Relays
- X6** – DI8-OR4: Assembly Group with 8 Digital Inputs and 4 Output Relays (NO / Form A)
- X100** – IEC 61850 / Modbus TCP / DNP3.0 TCP/UDP, Ethernet interface, 100 Mbit/s, RJ45 (BASE100-FX)
- X104** – IRIG-B00X, incl. System Contact (Supervision Contact)

MRA4-2F0AIA

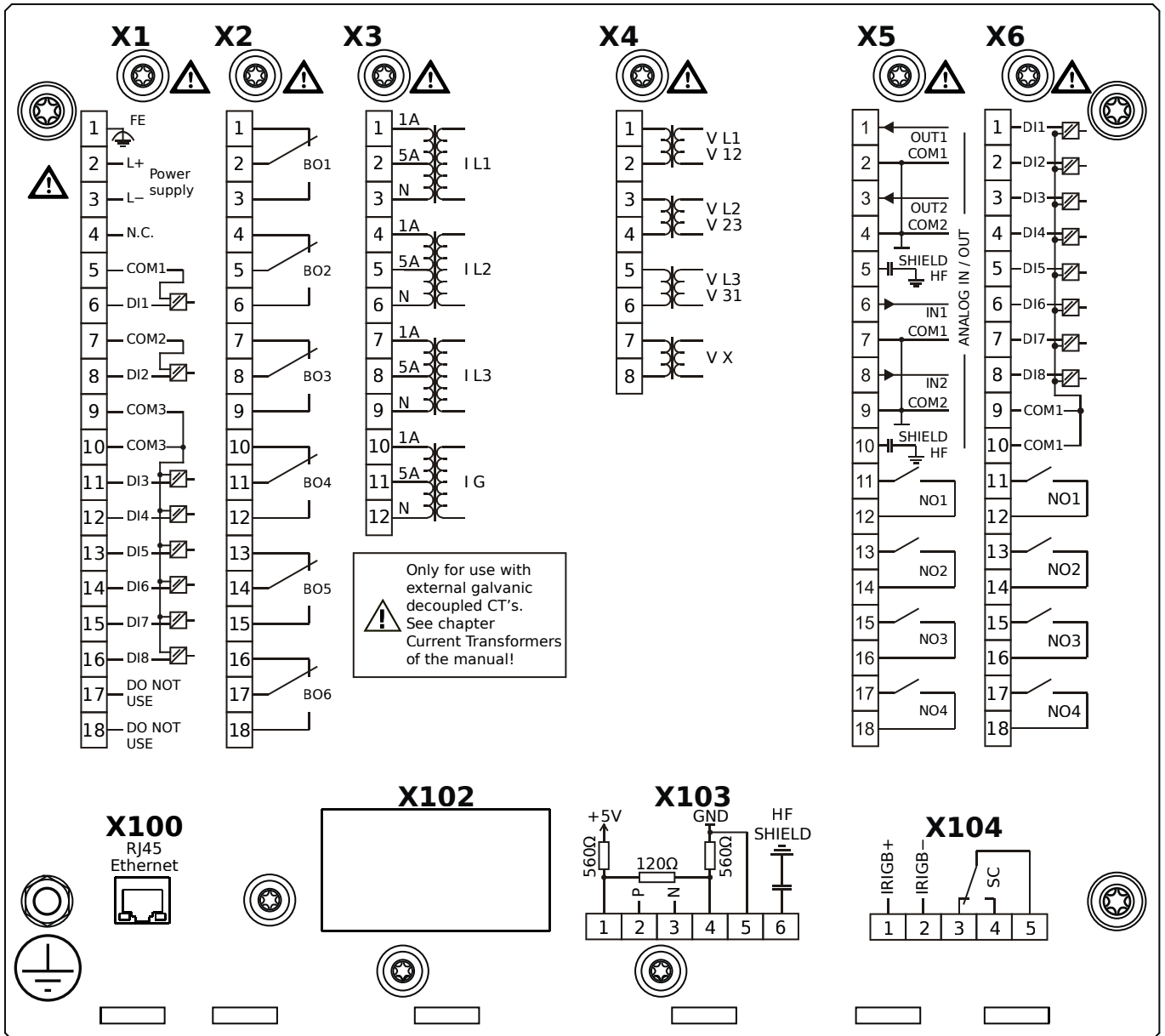

Housing B2, small display, door mounting

- X1** – DI8-X1: Wide-range power supply unit, incl. 2 non-grouped digital inputs and 6 grouped digital inputs
- X2** – OR6: Assembly Group with 6 Output Relays (Changeover / Form C)
- X3** – TI: Standard current measuring card
- X4** – TU: Card with 4 voltage transformer measuring inputs (0 ... 800 VAC, under UL: 0 ... 600 VAC)
- X5** – AnIO2-OR4: Assembly Group with 2 Analog Inputs, 2 Analog Outputs and 4 Output Relays
- X6** – DI8-OR4: Assembly Group with 8 Digital Inputs and 4 Output Relays (NO / Form A)
- X100** – Modbus TCP / DNP3.0 TCP/UDP, Ethernet interface, 100 Mbit/s, RJ45 (BASE100-FX)
- X103** – IEC 60870-5-103 / Modbus RTU / DNP3.0 RTU, RS485, Terminals
- X104** – IRIG-B00X, incl. System Contact (Supervision Contact)

MRA4-2F0AIB

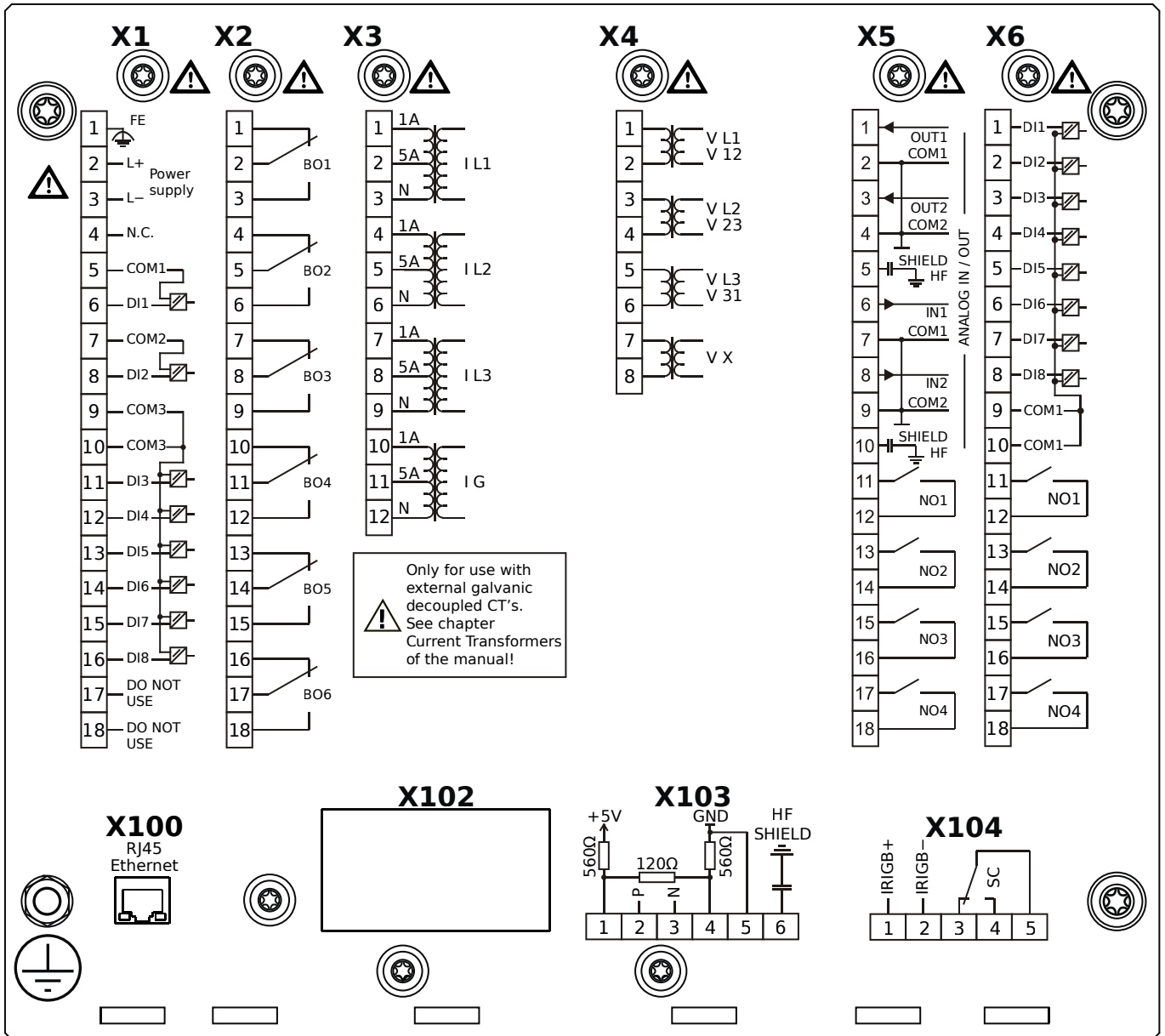

Housing B2, small display, door mounting

- + Conformal Coating (for installations in harsh environment)

- X1** – DI8-X1: Wide-range power supply unit, incl. 2 non-grouped digital inputs and 6 grouped digital inputs
- X2** – OR6: Assembly Group with 6 Output Relays (Changeover / Form C)
- X3** – TI: Standard current measuring card
- X4** – TU: Card with 4 voltage transformer measuring inputs (0 ... 800 VAC, under UL: 0 ... 600 VAC)
- X5** – AnIO2-OR4: Assembly Group with 2 Analog Inputs, 2 Analog Outputs and 4 Output Relays
- X6** – DI8-OR4: Assembly Group with 8 Digital Inputs and 4 Output Relays (NO / Form A)
- X100** – Modbus TCP / DNP3.0 TCP/UDP, Ethernet interface, 100 Mbit/s, RJ45 (BASE100-FX)
- X103** – IEC 60870-5-103 / Modbus RTU / DNP3.0 RTU, RS485, Terminals
- X104** – IRIG-B00X, incl. System Contact (Supervision Contact)

MRA4-2F0AKA

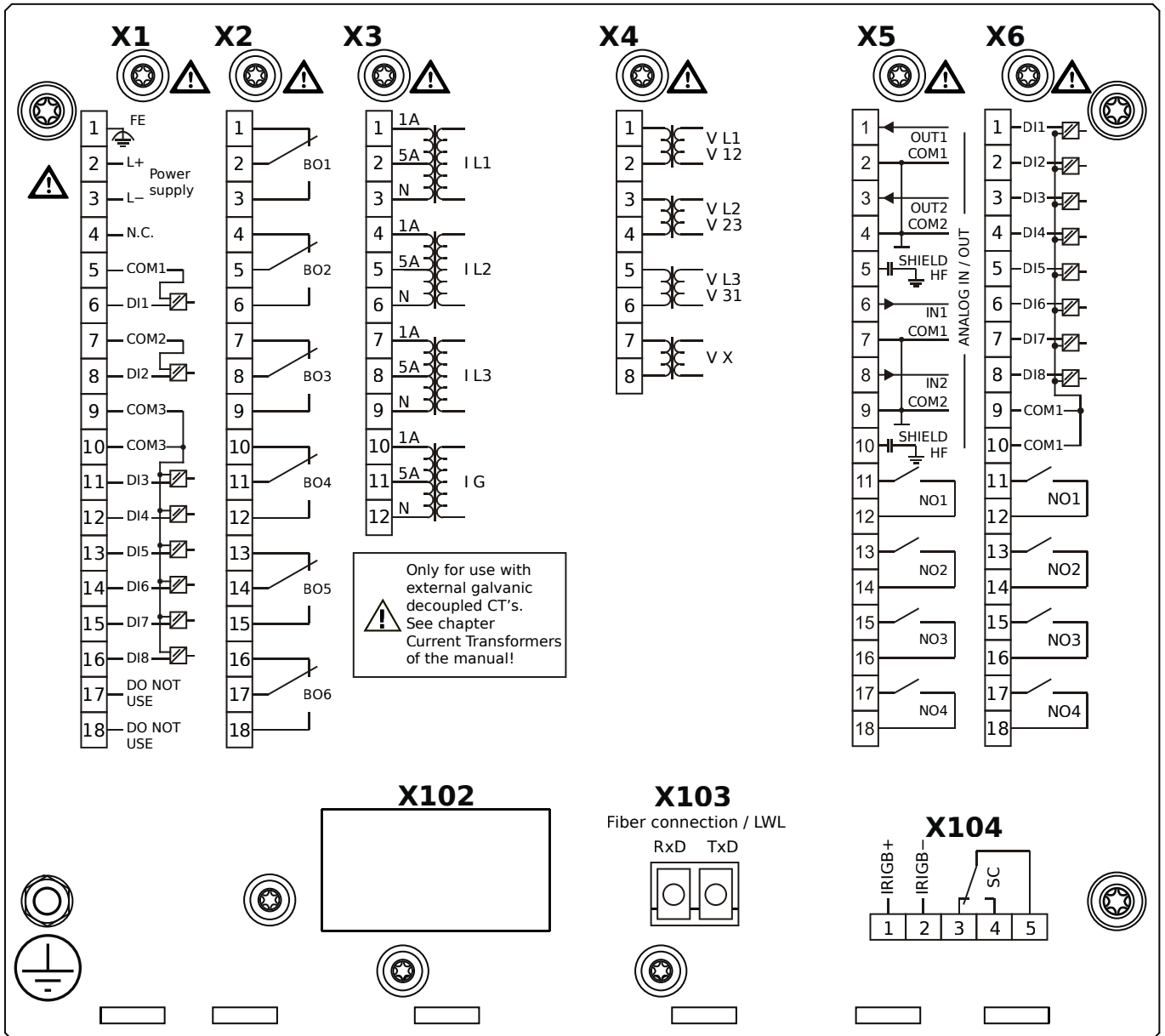

Housing B2, small display, door mounting

- X1** – DI8-X1: Wide-range power supply unit, incl. 2 non-grouped digital inputs and 6 grouped digital inputs
- X2** – OR6: Assembly Group with 6 Output Relays (Changeover / Form C)
- X3** – TI: Standard current measuring card
- X4** – TU: Card with 4 voltage transformer measuring inputs (0 ... 800 VAC, under UL: 0 ... 600 VAC)
- X5** – AnIO2-OR4: Assembly Group with 2 Analog Inputs, 2 Analog Outputs and 4 Output Relays
- X6** – DI8-OR4: Assembly Group with 8 Digital Inputs and 4 Output Relays (NO / Form A)
- X103** – IEC 61850 / Modbus TCP / DNP3.0 TCP/UDP, Fiber optics interface, LC Connector
- X104** – IRIG-B00X, incl. System Contact (Supervision Contact)

MRA4-2F0AKB

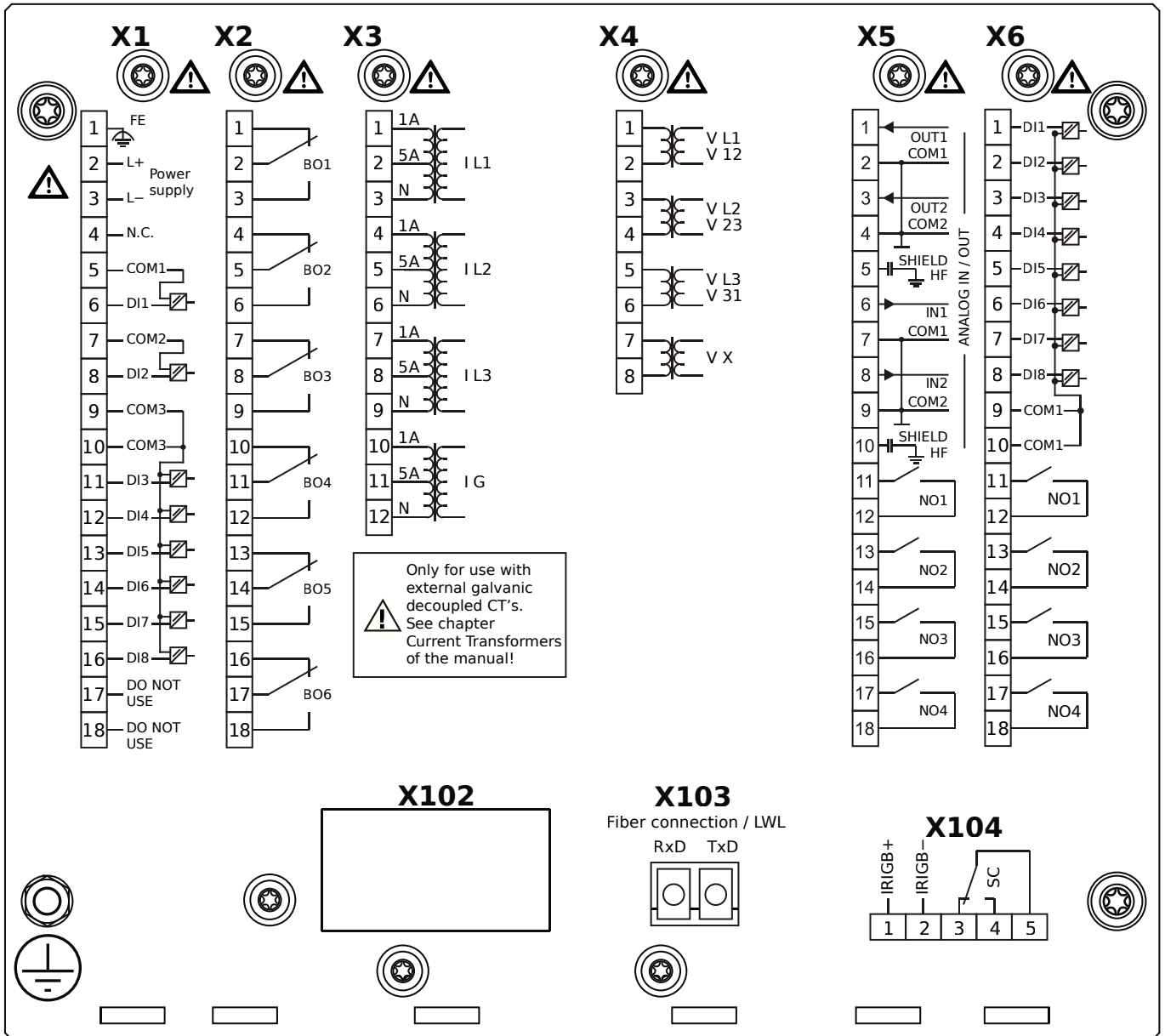

Housing B2, small display, door mounting

- + Conformal Coating (for installations in harsh environment)

- X1** – DI8-X1: Wide-range power supply unit, incl. 2 non-grouped digital inputs and 6 grouped digital inputs
- X2** – OR6: Assembly Group with 6 Output Relays (Changeover / Form C)
- X3** – TI: Standard current measuring card
- X4** – TU: Card with 4 voltage transformer measuring inputs (0 ... 800 VAC, under UL: 0 ... 600 VAC)
- X5** – AnIO2-OR4: Assembly Group with 2 Analog Inputs, 2 Analog Outputs and 4 Output Relays
- X6** – DI8-OR4: Assembly Group with 8 Digital Inputs and 4 Output Relays (NO / Form A)
- X103** – IEC 61850 / Modbus TCP / DNP3.0 TCP/UDP, Fiber optics interface, LC Connector
- X104** – IRIG-B00X, incl. System Contact (Supervision Contact)

MRA4-2F0ALA

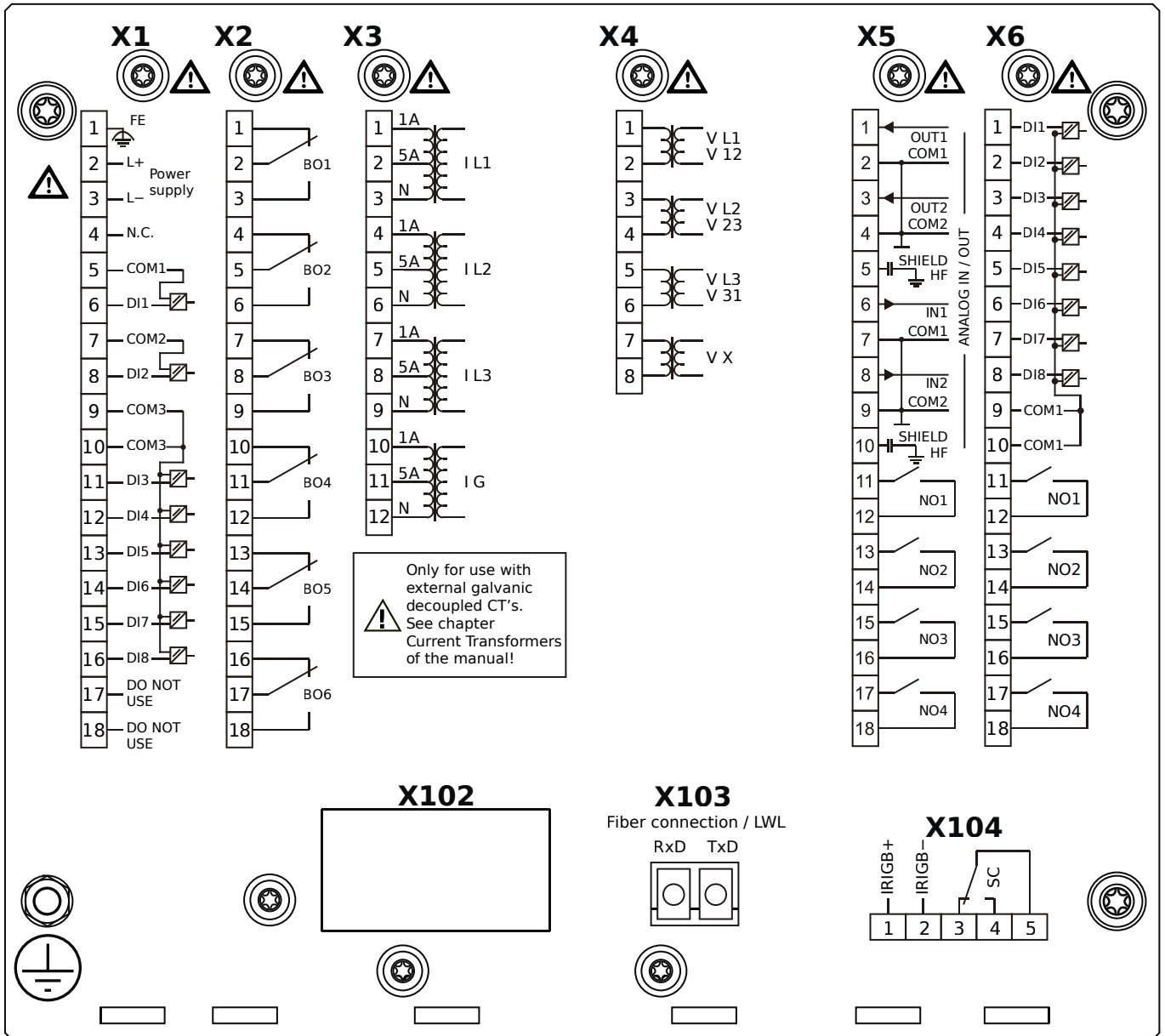

Housing B2, small display, door mounting

- X1** – DI8-X1: Wide-range power supply unit, incl. 2 non-grouped digital inputs and 6 grouped digital inputs
- X2** – OR6: Assembly Group with 6 Output Relays (Changeover / Form C)
- X3** – TI: Standard current measuring card
- X4** – TU: Card with 4 voltage transformer measuring inputs (0 ... 800 VAC, under UL: 0 ... 600 VAC)
- X5** – AnIO2-OR4: Assembly Group with 2 Analog Inputs, 2 Analog Outputs and 4 Output Relays
- X6** – DI8-OR4: Assembly Group with 8 Digital Inputs and 4 Output Relays (NO / Form A)
- X103** – Modbus TCP / DNP3.0 TCP/UDP, Fiber optics interface, LC Connector
- X104** – IRIG-B00X, incl. System Contact (Supervision Contact)

MRA4-2F0ALB

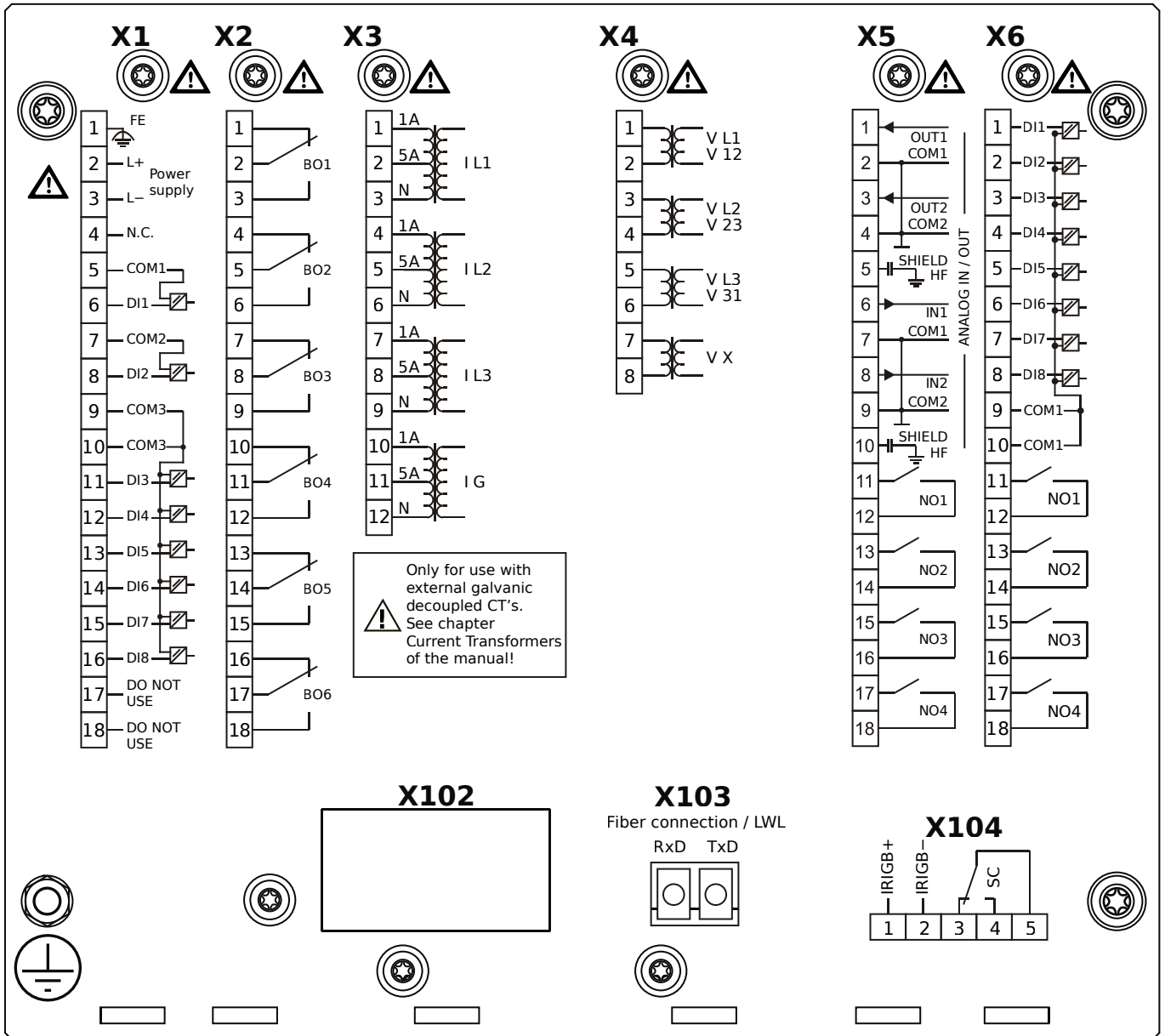

Housing B2, small display, door mounting

- + Conformal Coating (for installations in harsh environment)

- X1** – DI8-X1: Wide-range power supply unit, incl. 2 non-grouped digital inputs and 6 grouped digital inputs
- X2** – OR6: Assembly Group with 6 Output Relays (Changeover / Form C)
- X3** – TI: Standard current measuring card
- X4** – TU: Card with 4 voltage transformer measuring inputs (0 ... 800 VAC, under UL: 0 ... 600 VAC)
- X5** – AnIO2-OR4: Assembly Group with 2 Analog Inputs, 2 Analog Outputs and 4 Output Relays
- X6** – DI8-OR4: Assembly Group with 8 Digital Inputs and 4 Output Relays (NO / Form A)
- X103** – Modbus TCP / DNP3.0 TCP/UDP, Fiber optics interface, LC Connector
- X104** – IRIG-B00X, incl. System Contact (Supervision Contact)

MRA4-2F0ATA

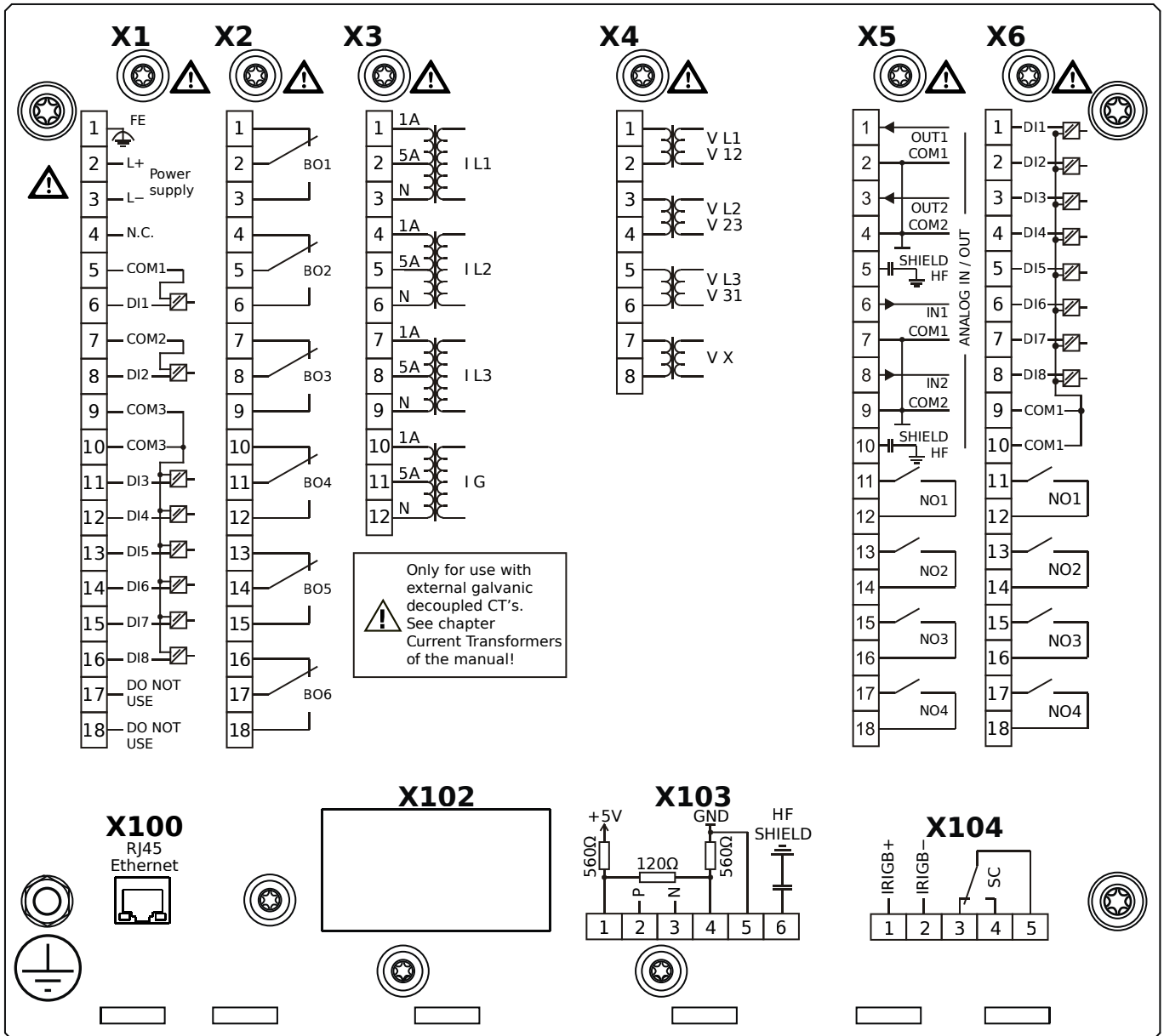

Housing B2, small display, door mounting

- X1** – DI8-X1: Wide-range power supply unit, incl. 2 non-grouped digital inputs and 6 grouped digital inputs
- X2** – OR6: Assembly Group with 6 Output Relays (Changeover / Form C)
- X3** – TI: Standard current measuring card
- X4** – TU: Card with 4 voltage transformer measuring inputs (0 ... 800 VAC, under UL: 0 ... 600 VAC)
- X5** – AnIO2-OR4: Assembly Group with 2 Analog Inputs, 2 Analog Outputs and 4 Output Relays
- X6** – DI8-OR4: Assembly Group with 8 Digital Inputs and 4 Output Relays (NO / Form A)
- X100** – IEC 61850 / Modbus TCP / DNP3.0 TCP/UDP, Ethernet interface, 100 Mbit/s, RJ45 (BASE100-FX)
- X103** – IEC 60870-5-103 / Modbus RTU / DNP3.0 RTU, RS485, Terminals
- X104** – IRIG-B00X, incl. System Contact (Supervision Contact)

MRA4-2F0ATB

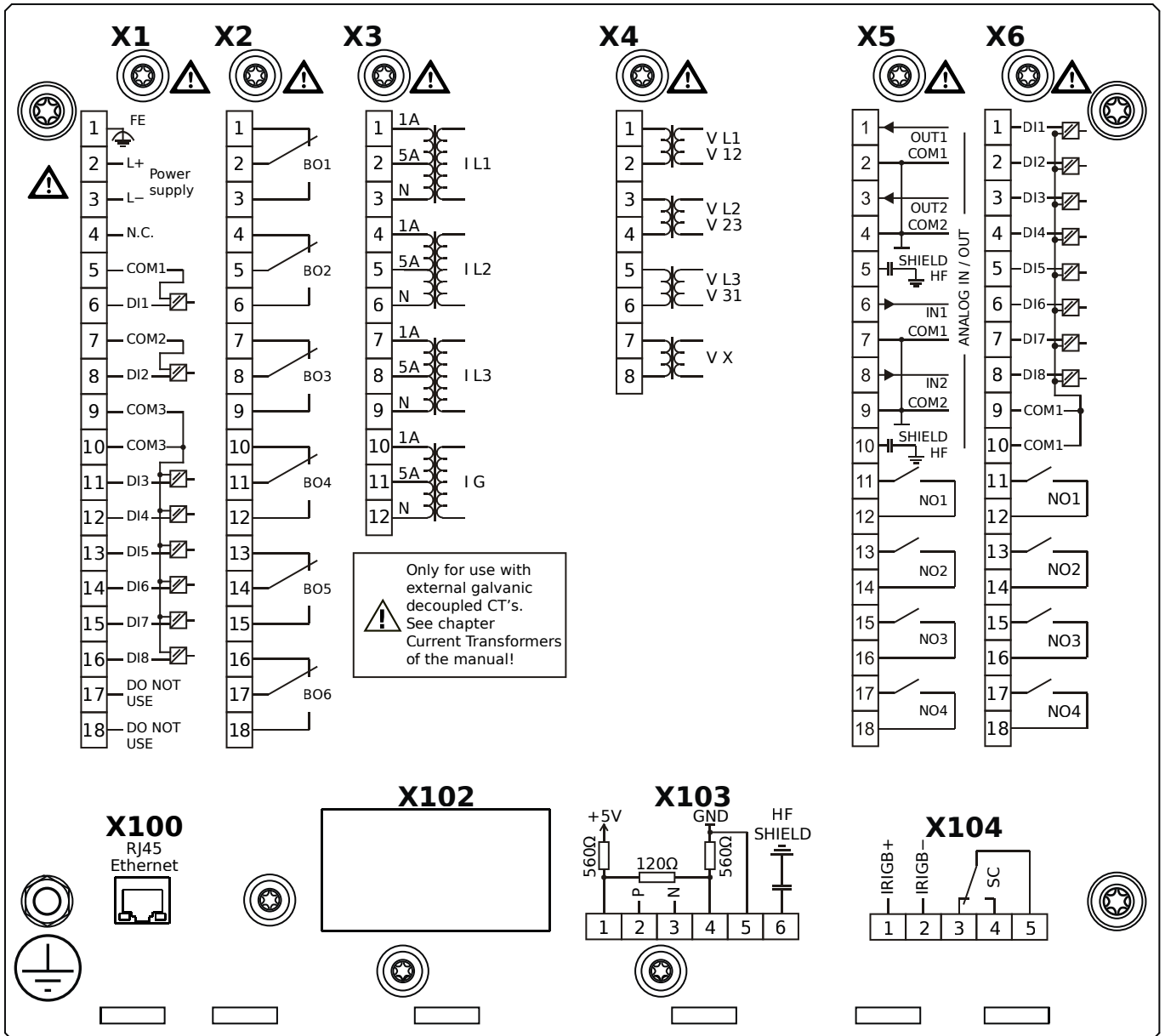

Housing B2, small display, door mounting

- + Conformal Coating (for installations in harsh environment)

- X1** – DI8-X1: Wide-range power supply unit, incl. 2 non-grouped digital inputs and 6 grouped digital inputs
- X2** – OR6: Assembly Group with 6 Output Relays (Changeover / Form C)
- X3** – TI: Standard current measuring card
- X4** – TU: Card with 4 voltage transformer measuring inputs (0 ... 800 VAC, under UL: 0 ... 600 VAC)
- X5** – AnIO2-OR4: Assembly Group with 2 Analog Inputs, 2 Analog Outputs and 4 Output Relays
- X6** – DI8-OR4: Assembly Group with 8 Digital Inputs and 4 Output Relays (NO / Form A)
- X100** – IEC 61850 / Modbus TCP / DNP3.0 TCP/UDP, Ethernet interface, 100 Mbit/s, RJ45 (BASE100-FX)
- X103** – IEC 60870-5-103 / Modbus RTU / DNP3.0 RTU, RS485, Terminals
- X104** – IRIG-B00X, incl. System Contact (Supervision Contact)

MRA4-2F0BAA

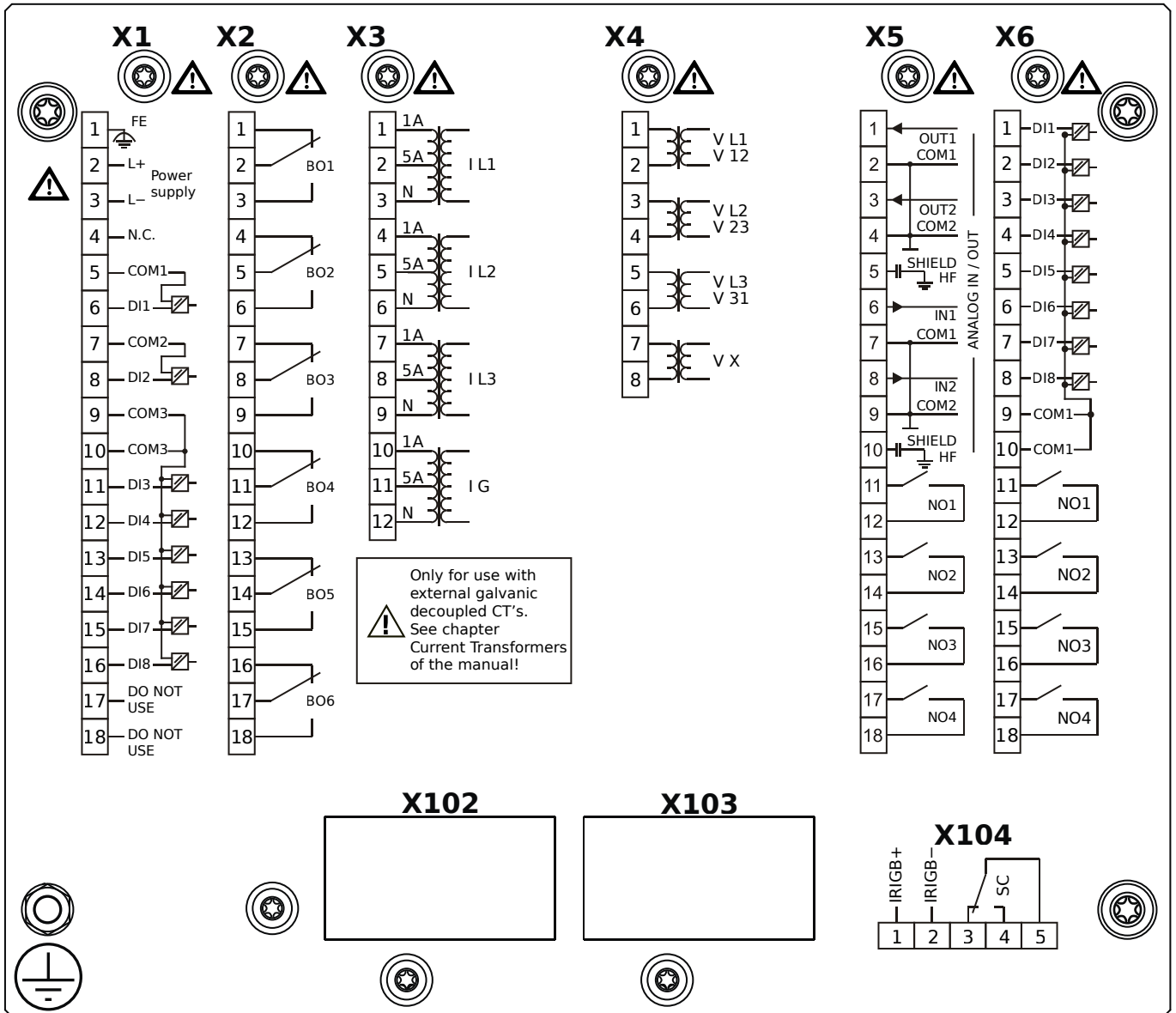

Housing B2, small display, 19" rack mounting

- X1** – DI8-X1: Wide-range power supply unit, incl. 2 non-grouped digital inputs and 6 grouped digital inputs
- X2** – OR6: Assembly Group with 6 Output Relays (Changeover / Form C)
- X3** – TI: Standard current measuring card
- X4** – TU: Card with 4 voltage transformer measuring inputs (0 ... 800 VAC, under UL: 0 ... 600 VAC)
- X5** – AnIO2-OR4: Assembly Group with 2 Analog Inputs, 2 Analog Outputs and 4 Output Relays
- X6** – DI8-OR4: Assembly Group with 8 Digital Inputs and 4 Output Relays (NO / Form A)
- X104** – IRIG-B00X, incl. System Contact (Supervision Contact)

MRA4-2F0BAB

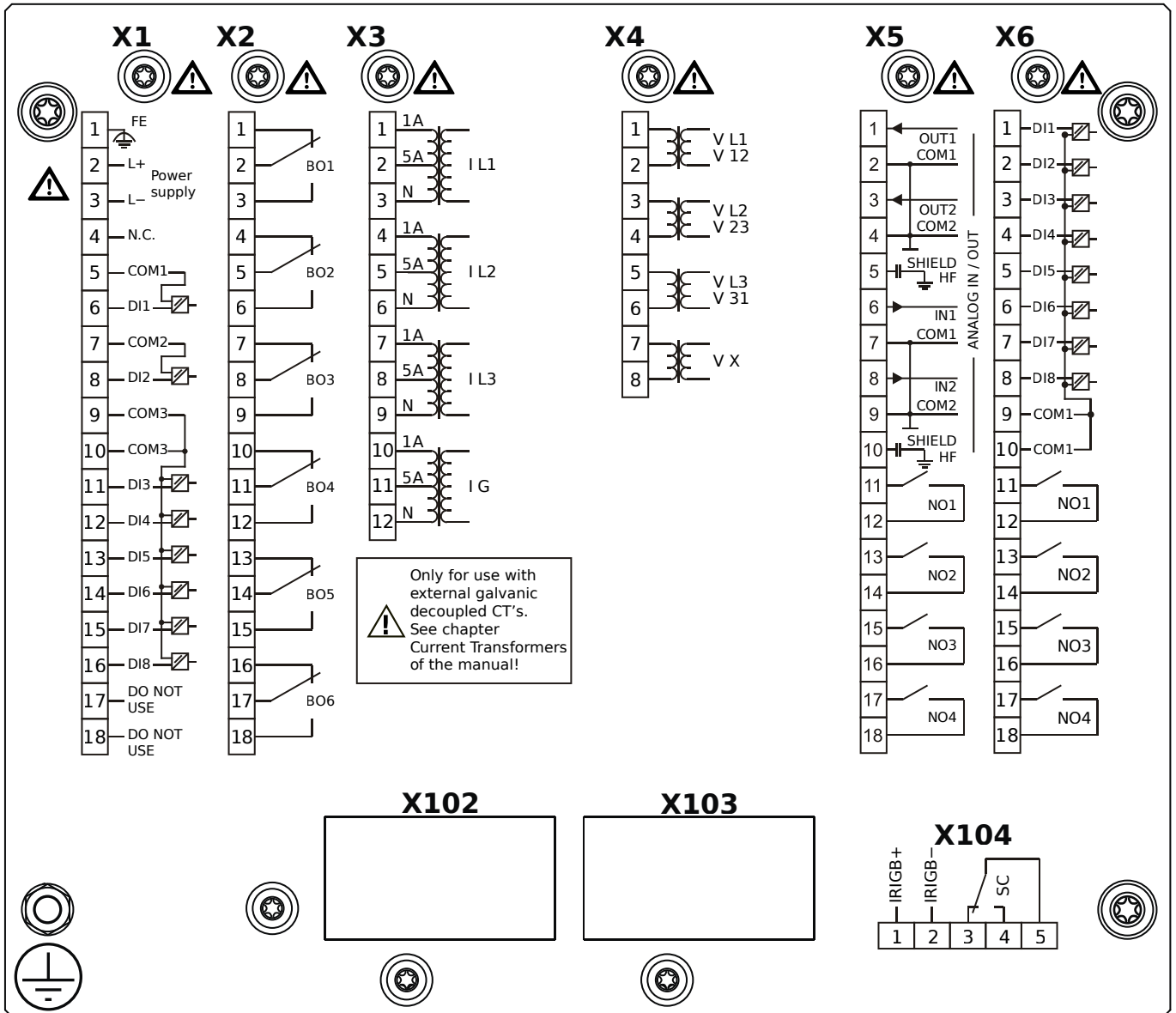

Housing B2, small display, 19" rack mounting

+ Conformal Coating (for installations in harsh environment)

- X1** – DI8-X1: Wide-range power supply unit, incl. 2 non-grouped digital inputs and 6 grouped digital inputs
- X2** – OR6: Assembly Group with 6 Output Relays (Changeover / Form C)
- X3** – TI: Standard current measuring card
- X4** – TU: Card with 4 voltage transformer measuring inputs (0 ... 800 VAC, under UL: 0 ... 600 VAC)
- X5** – AnIO2-OR4: Assembly Group with 2 Analog Inputs, 2 Analog Outputs and 4 Output Relays
- X6** – DI8-OR4: Assembly Group with 8 Digital Inputs and 4 Output Relays (NO / Form A)
- X104** – IRIG-B00X, incl. System Contact (Supervision Contact)

MRA4-2F0BBA

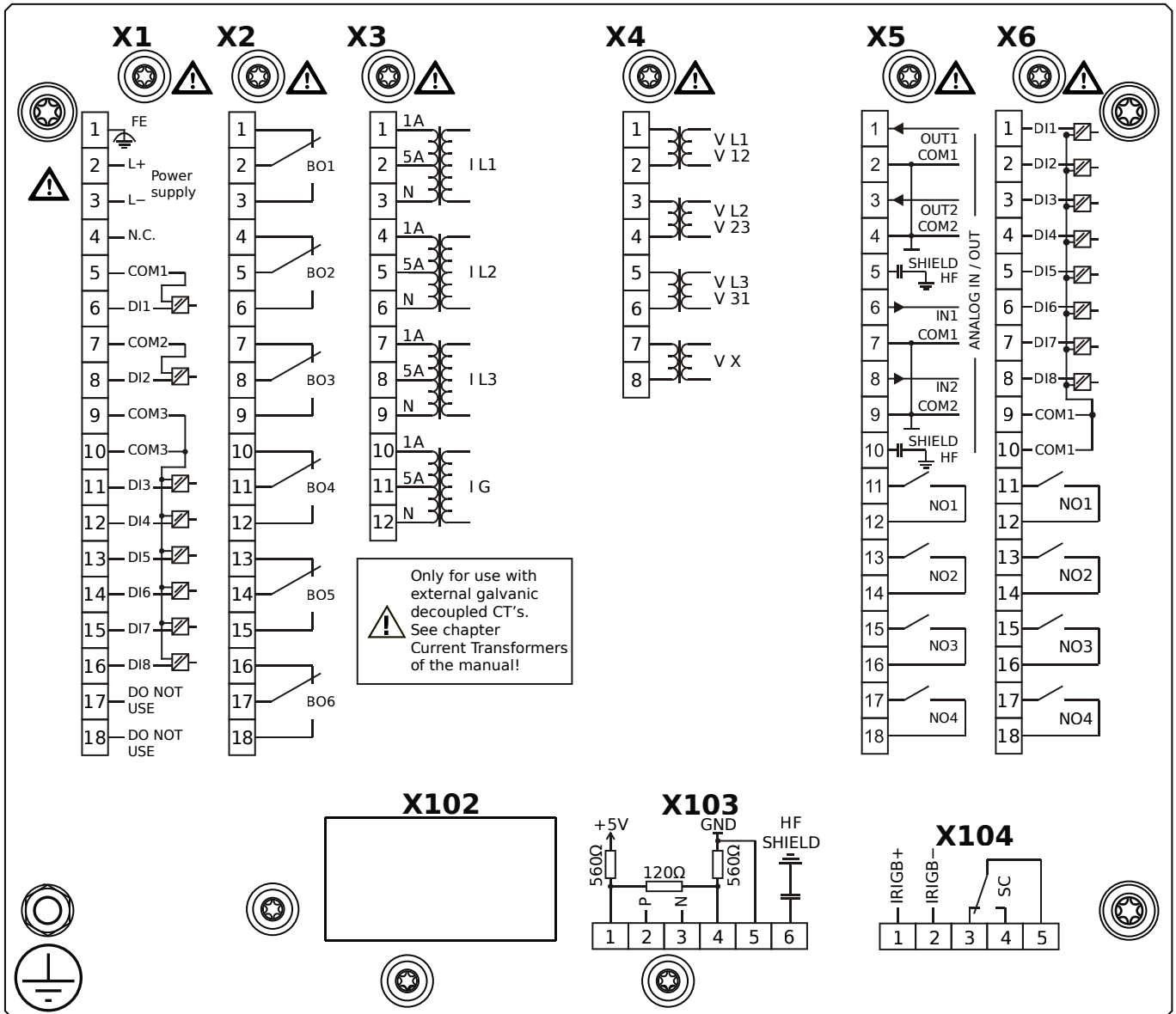

Housing B2, small display, 19" rack mounting

- X1** – DI8-X1: Wide-range power supply unit, incl. 2 non-grouped digital inputs and 6 grouped digital inputs
- X2** – OR6: Assembly Group with 6 Output Relays (Changeover / Form C)
- X3** – TI: Standard current measuring card
- X4** – TU: Card with 4 voltage transformer measuring inputs (0 ... 800 VAC, under UL: 0 ... 600 VAC)
- X5** – AnIO2-OR4: Assembly Group with 2 Analog Inputs, 2 Analog Outputs and 4 Output Relays
- X6** – DI8-OR4: Assembly Group with 8 Digital Inputs and 4 Output Relays (NO / Form A)
- X103** – Modbus RTU / IEC 60870-5-103 / DNP3.0 RTU, RS485, Terminals
- X104** – IRIG-B00X, incl. System Contact (Supervision Contact)

MRA4-2F0BBB

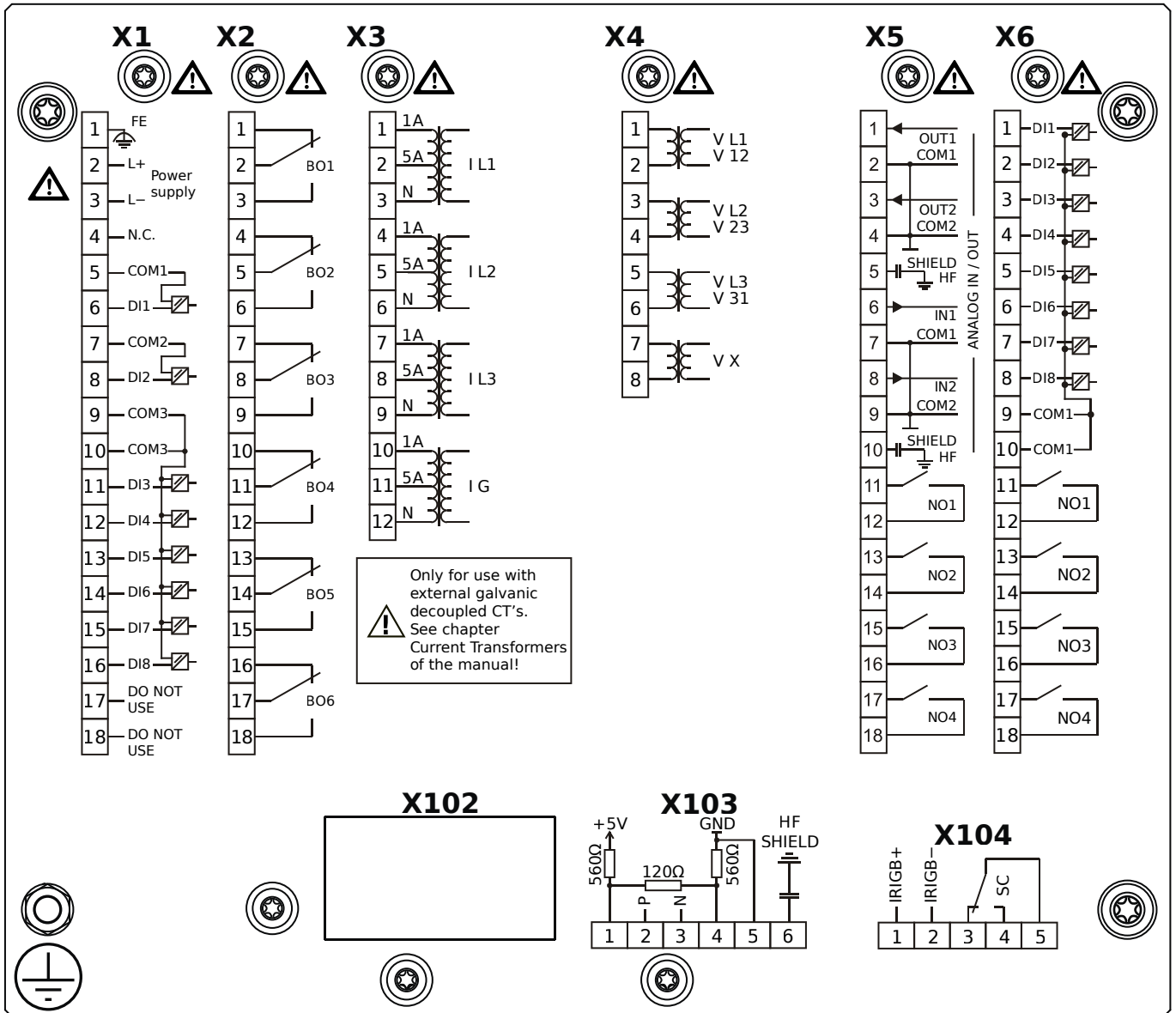

Housing B2, small display, 19" rack mounting

+ Conformal Coating (for installations in harsh environment)

- X1** – DI8-X1: Wide-range power supply unit, incl. 2 non-grouped digital inputs and 6 grouped digital inputs
- X2** – OR6: Assembly Group with 6 Output Relays (Changeover / Form C)
- X3** – TI: Standard current measuring card
- X4** – TU: Card with 4 voltage transformer measuring inputs (0 ... 800 VAC, under UL: 0 ... 600 VAC)
- X5** – AnIO2-OR4: Assembly Group with 2 Analog Inputs, 2 Analog Outputs and 4 Output Relays
- X6** – DI8-OR4: Assembly Group with 8 Digital Inputs and 4 Output Relays (NO / Form A)
- X103** – Modbus RTU / IEC 60870-5-103 / DNP3.0 RTU, RS485, Terminals
- X104** – IRIG-B00X, incl. System Contact (Supervision Contact)

MRA4-2F0BCA

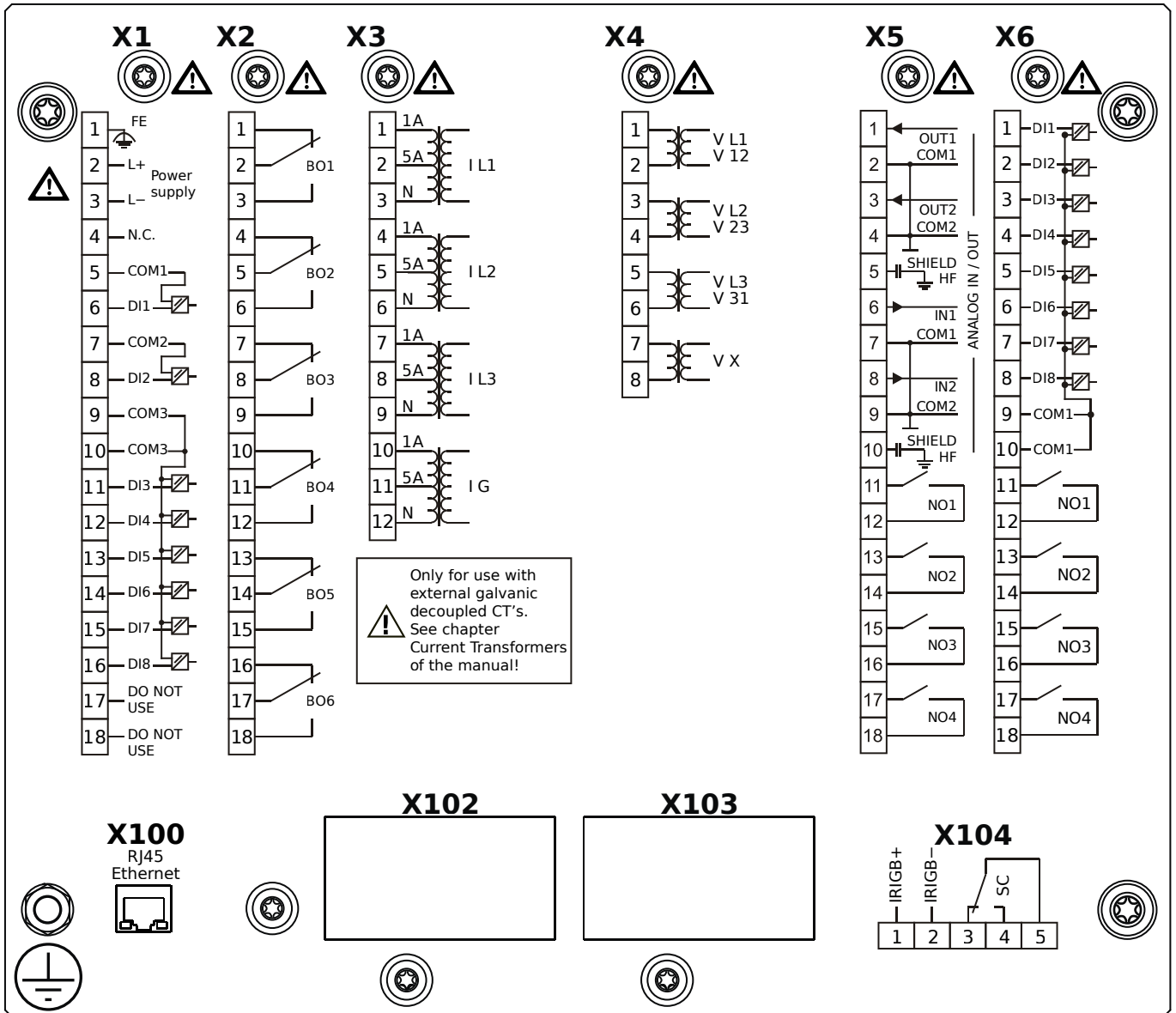

Housing B2, small display, 19" rack mounting

- X1** – DI8-X1: Wide-range power supply unit, incl. 2 non-grouped digital inputs and 6 grouped digital inputs
- X2** – OR6: Assembly Group with 6 Output Relays (Changeover / Form C)
- X3** – TI: Standard current measuring card
- X4** – TU: Card with 4 voltage transformer measuring inputs (0 ... 800 VAC, under UL: 0 ... 600 VAC)
- X5** – AnIO2-OR4: Assembly Group with 2 Analog Inputs, 2 Analog Outputs and 4 Output Relays
- X6** – DI8-OR4: Assembly Group with 8 Digital Inputs and 4 Output Relays (NO / Form A)
- X100** – Modbus TCP / DNP3.0 TCP/UDP, Ethernet interface, 100 Mbit/s, RJ45 (BASE100-FX)
- X104** – IRIG-B00X, incl. System Contact (Supervision Contact)

MRA4-2F0BCB

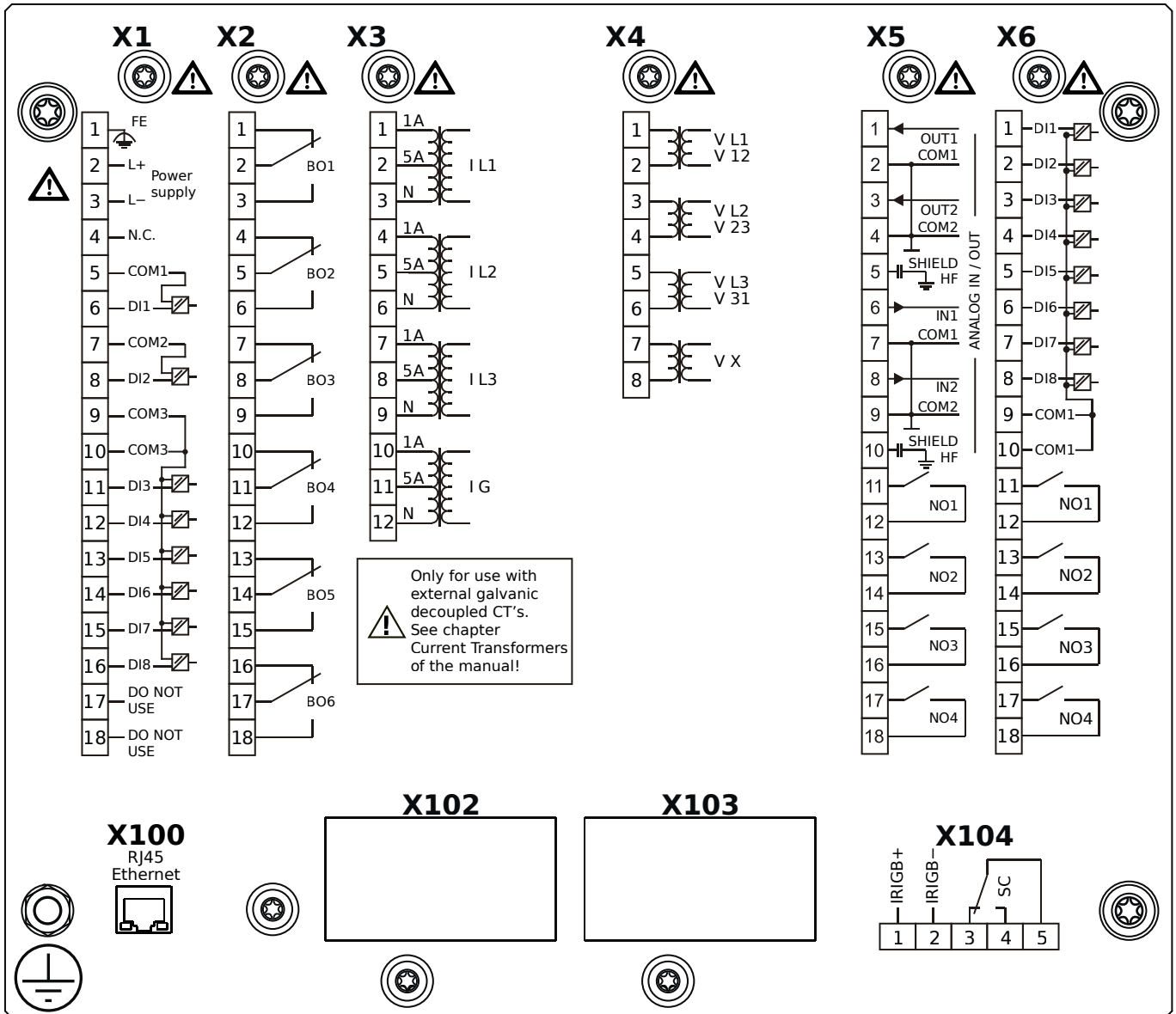

Housing B2, small display, 19" rack mounting

- + Conformal Coating (for installations in harsh environment)

- X1** – DI8-X1: Wide-range power supply unit, incl. 2 non-grouped digital inputs and 6 grouped digital inputs
- X2** – OR6: Assembly Group with 6 Output Relays (Changeover / Form C)
- X3** – TI: Standard current measuring card
- X4** – TU: Card with 4 voltage transformer measuring inputs (0 ... 800 VAC, under UL: 0 ... 600 VAC)
- X5** – AnIO2-OR4: Assembly Group with 2 Analog Inputs, 2 Analog Outputs and 4 Output Relays
- X6** – DI8-OR4: Assembly Group with 8 Digital Inputs and 4 Output Relays (NO / Form A)
- X100** – Modbus TCP / DNP3.0 TCP/UDP, Ethernet interface, 100 Mbit/s, RJ45 (BASE100-FX)
- X104** – IRIG-B00X, incl. System Contact (Supervision Contact)

MRA4-2F0BDA

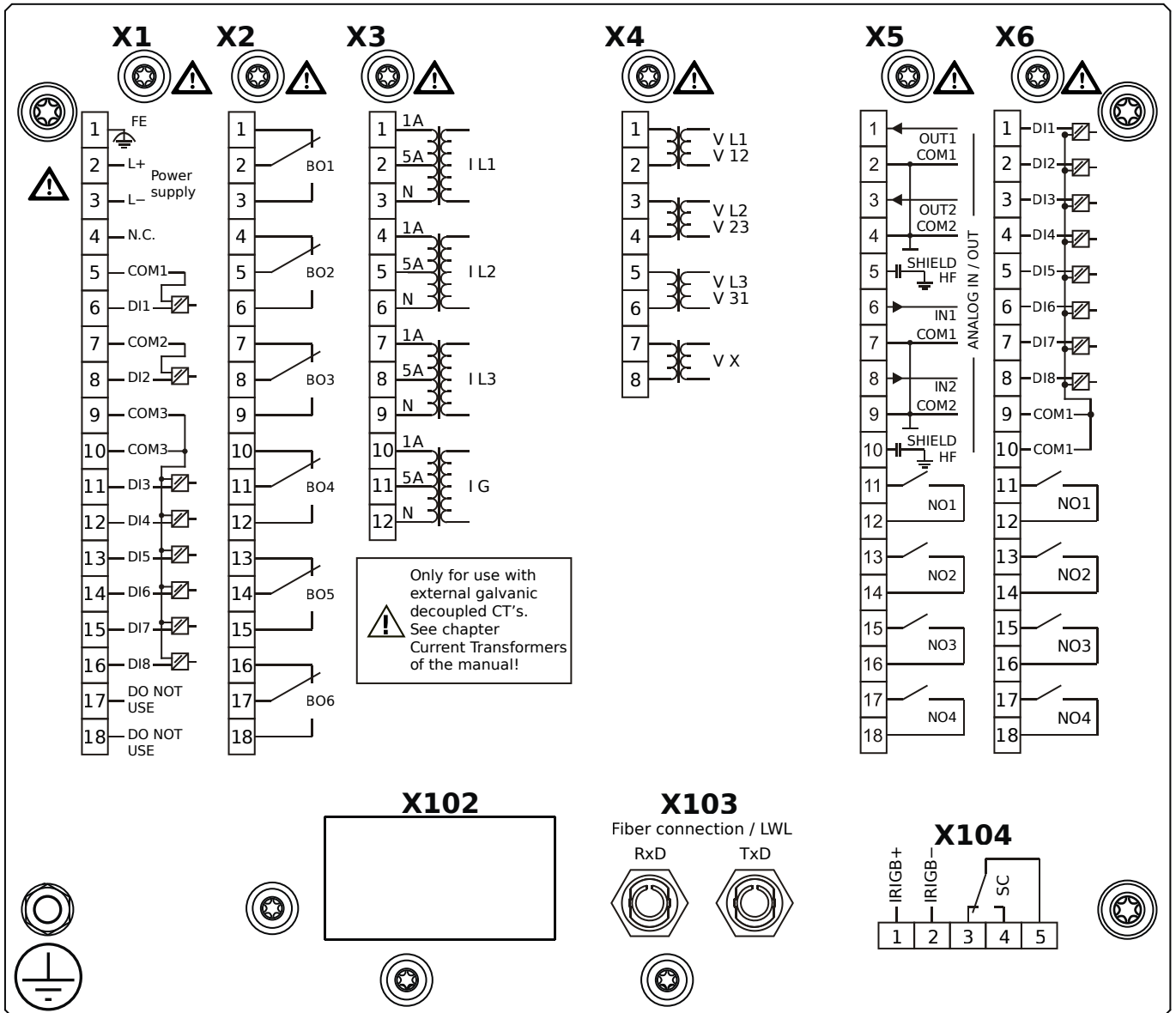

Housing B2, small display, 19" rack mounting

- X1** – DI8-X1: Wide-range power supply unit, incl. 2 non-grouped digital inputs and 6 grouped digital inputs
- X2** – OR6: Assembly Group with 6 Output Relays (Changeover / Form C)
- X3** – TI: Standard current measuring card
- X4** – TU: Card with 4 voltage transformer measuring inputs (0 ... 800 VAC, under UL: 0 ... 600 VAC)
- X5** – AnIO2-OR4: Assembly Group with 2 Analog Inputs, 2 Analog Outputs and 4 Output Relays
- X6** – DI8-OR4: Assembly Group with 8 Digital Inputs and 4 Output Relays (NO / Form A)
- X103** – Profibus-DP, Fiber optics interface, ST Connector
- X104** – IRIG-B00X, incl. System Contact (Supervision Contact)

MRA4-2F0BDB

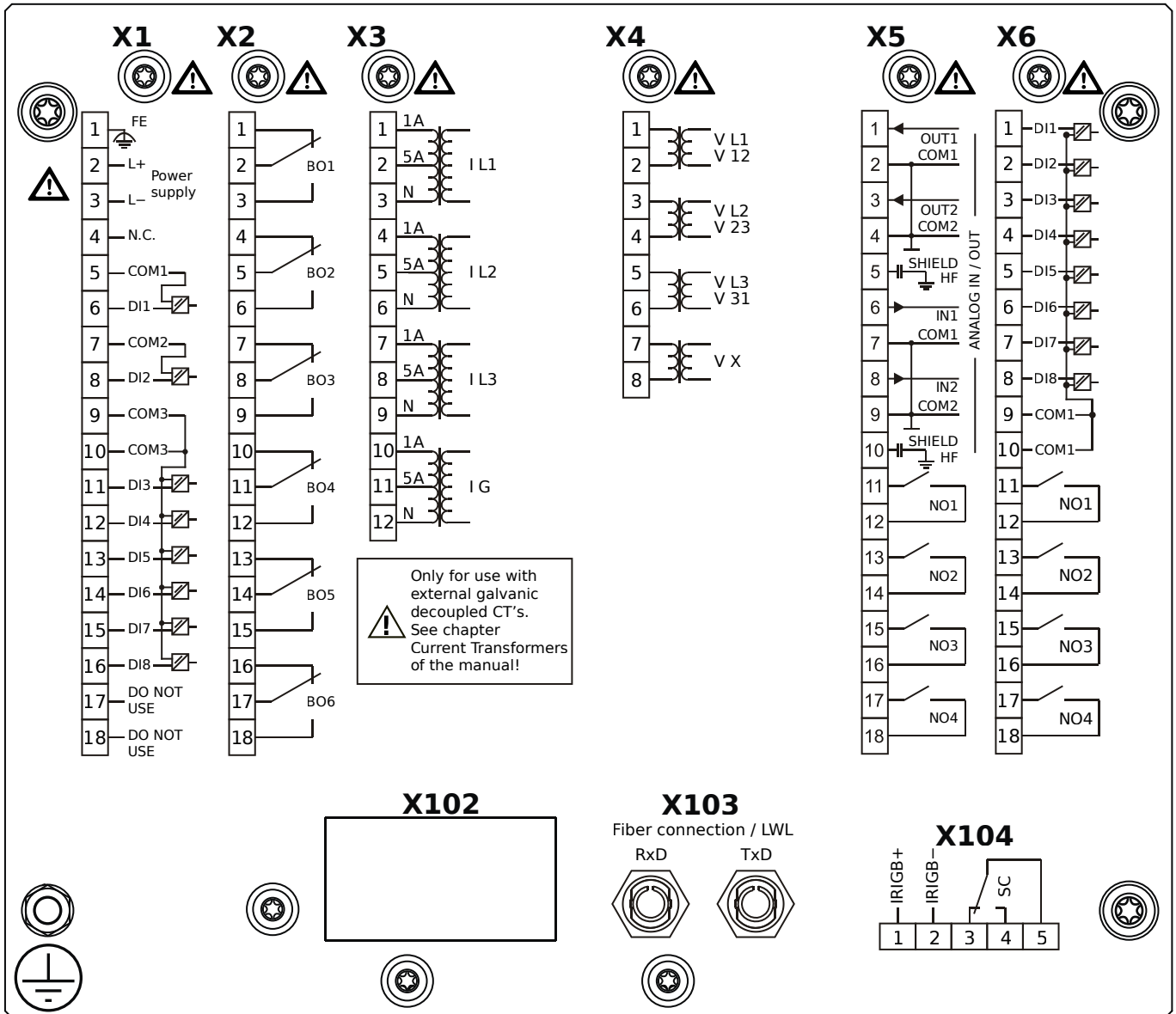

Housing B2, small display, 19" rack mounting

+ Conformal Coating (for installations in harsh environment)

- X1** – DI8-X1: Wide-range power supply unit, incl. 2 non-grouped digital inputs and 6 grouped digital inputs
- X2** – OR6: Assembly Group with 6 Output Relays (Changeover / Form C)
- X3** – TI: Standard current measuring card
- X4** – TU: Card with 4 voltage transformer measuring inputs (0 ... 800 VAC, under UL: 0 ... 600 VAC)
- X5** – AnIO2-OR4: Assembly Group with 2 Analog Inputs, 2 Analog Outputs and 4 Output Relays
- X6** – DI8-OR4: Assembly Group with 8 Digital Inputs and 4 Output Relays (NO / Form A)
- X103** – Profibus-DP, Fiber optics interface, ST Connector
- X104** – IRIG-B00X, incl. System Contact (Supervision Contact)

MRA4-2F0BEA

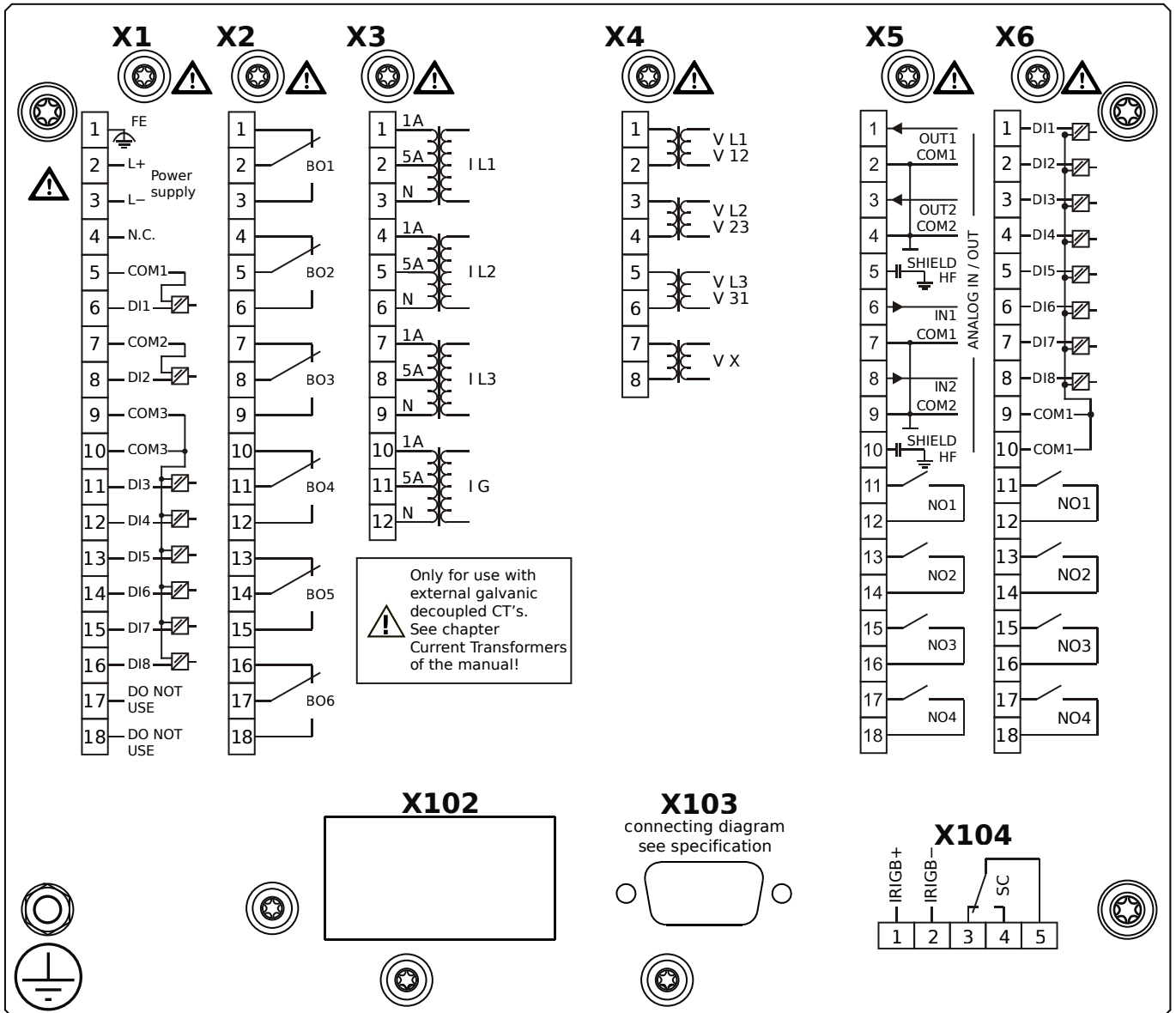

Housing B2, small display, 19" rack mounting

- X1** – DI8-X1: Wide-range power supply unit, incl. 2 non-grouped digital inputs and 6 grouped digital inputs
- X2** – OR6: Assembly Group with 6 Output Relays (Changeover / Form C)
- X3** – TI: Standard current measuring card
- X4** – TU: Card with 4 voltage transformer measuring inputs (0 ... 800 VAC, under UL: 0 ... 600 VAC)
- X5** – AnIO2-OR4: Assembly Group with 2 Analog Inputs, 2 Analog Outputs and 4 Output Relays
- X6** – DI8-OR4: Assembly Group with 8 Digital Inputs and 4 Output Relays (NO / Form A)
- X103** – Profibus-DP, RS485, D-SUB
- X104** – IRIG-B00X, incl. System Contact (Supervision Contact)

MRA4-2F0BEB

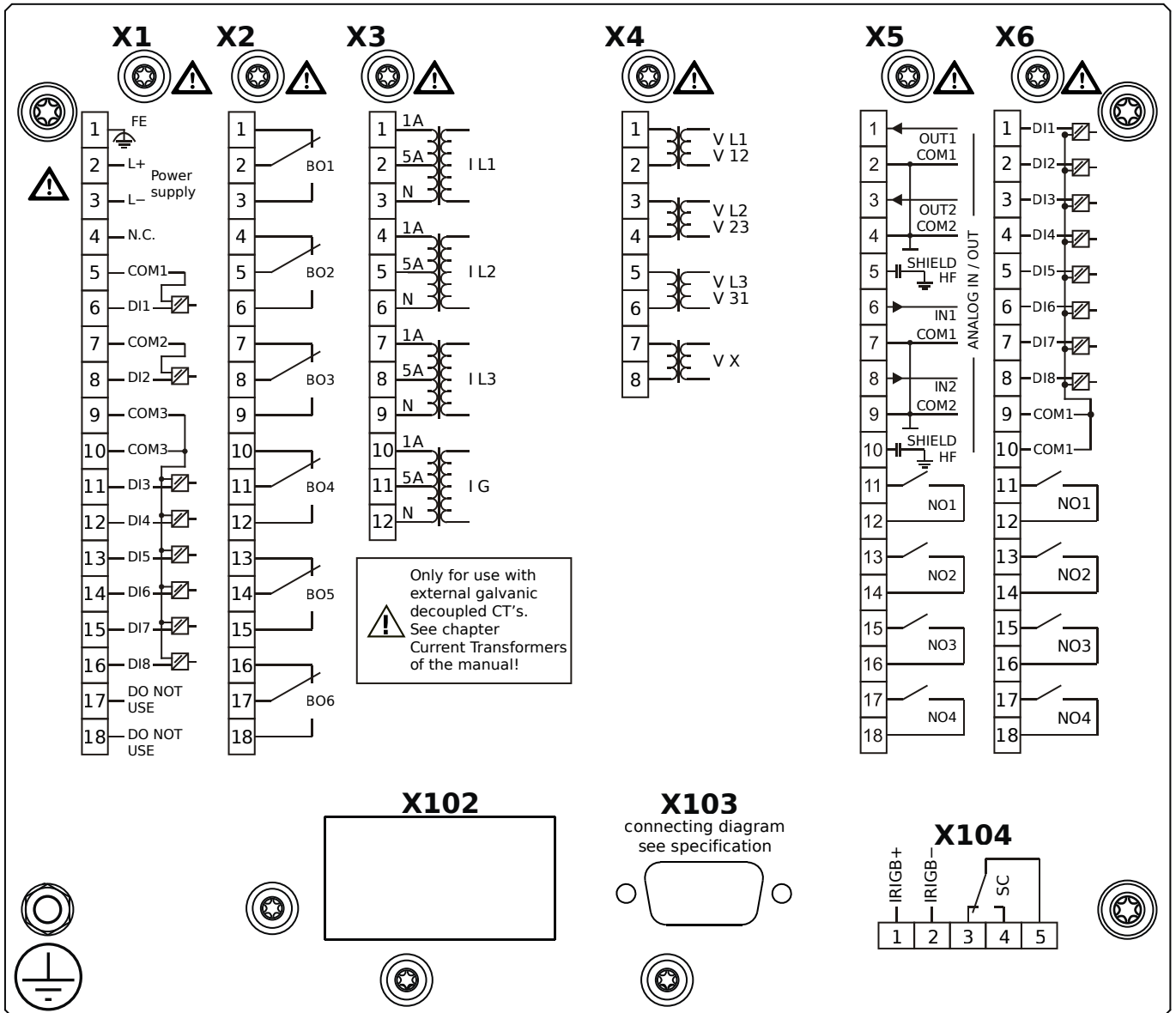

Housing B2, small display, 19" rack mounting

+ Conformal Coating (for installations in harsh environment)

- X1** – DI8-X1: Wide-range power supply unit, incl. 2 non-grouped digital inputs and 6 grouped digital inputs
- X2** – OR6: Assembly Group with 6 Output Relays (Changeover / Form C)
- X3** – TI: Standard current measuring card
- X4** – TU: Card with 4 voltage transformer measuring inputs (0 ... 800 VAC, under UL: 0 ... 600 VAC)
- X5** – AnIO2-OR4: Assembly Group with 2 Analog Inputs, 2 Analog Outputs and 4 Output Relays
- X6** – DI8-OR4: Assembly Group with 8 Digital Inputs and 4 Output Relays (NO / Form A)
- X103** – Profibus-DP, RS485, D-SUB
- X104** – IRIG-B00X, incl. System Contact (Supervision Contact)

MRA4-2F0BFA

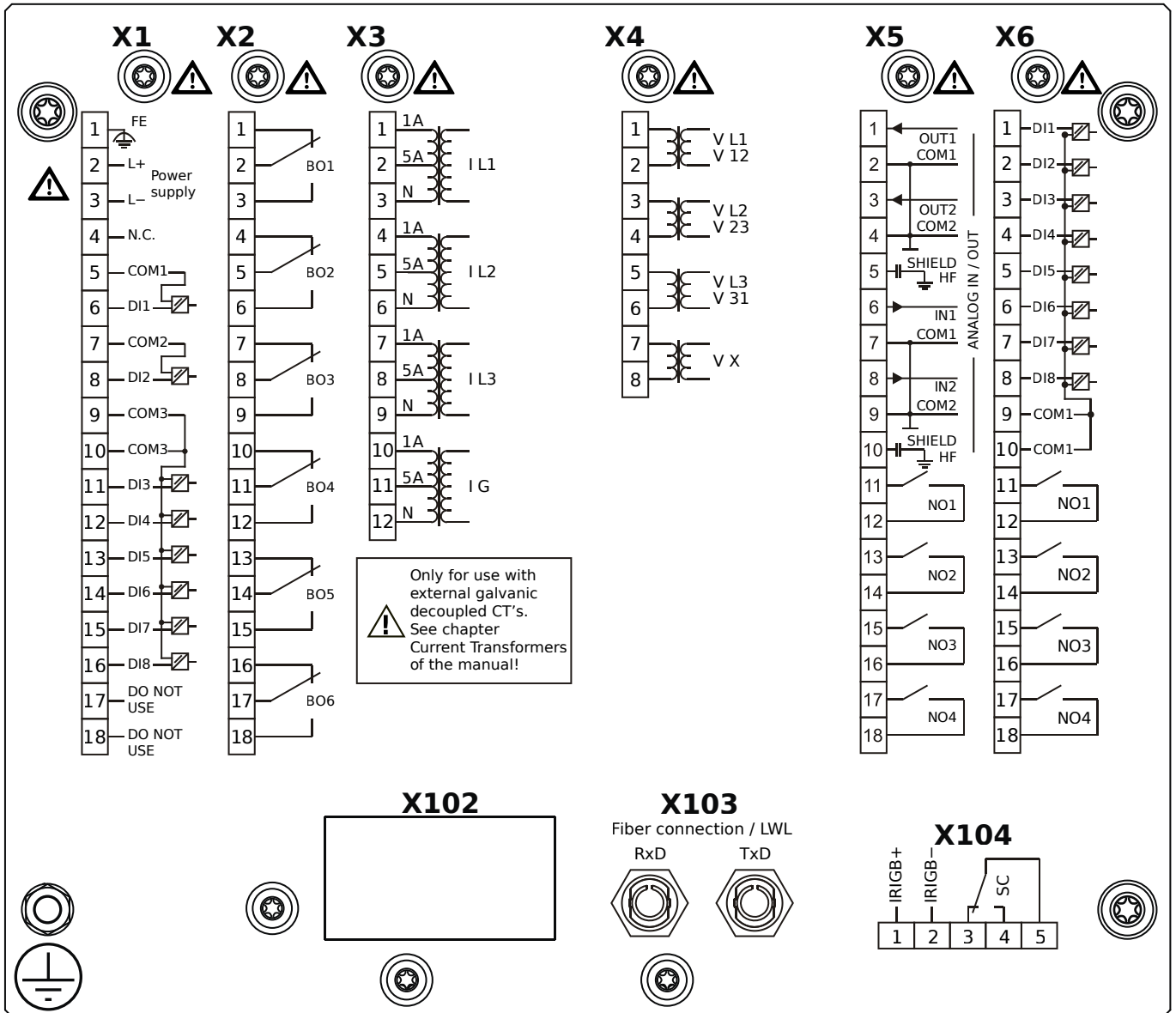

Housing B2, small display, 19" rack mounting

- X1** – DI8-X1: Wide-range power supply unit, incl. 2 non-grouped digital inputs and 6 grouped digital inputs
- X2** – OR6: Assembly Group with 6 Output Relays (Changeover / Form C)
- X3** – TI: Standard current measuring card
- X4** – TU: Card with 4 voltage transformer measuring inputs (0 ... 800 VAC, under UL: 0 ... 600 VAC)
- X5** – AnIO2-OR4: Assembly Group with 2 Analog Inputs, 2 Analog Outputs and 4 Output Relays
- X6** – DI8-OR4: Assembly Group with 8 Digital Inputs and 4 Output Relays (NO / Form A)
- X103** – Modbus RTU / IEC 60870-5-103 / DNP3.0 RTU, Fiber optics interface, ST Connector
- X104** – IRIG-B00X, incl. System Contact (Supervision Contact)

MRA4-2F0BFB

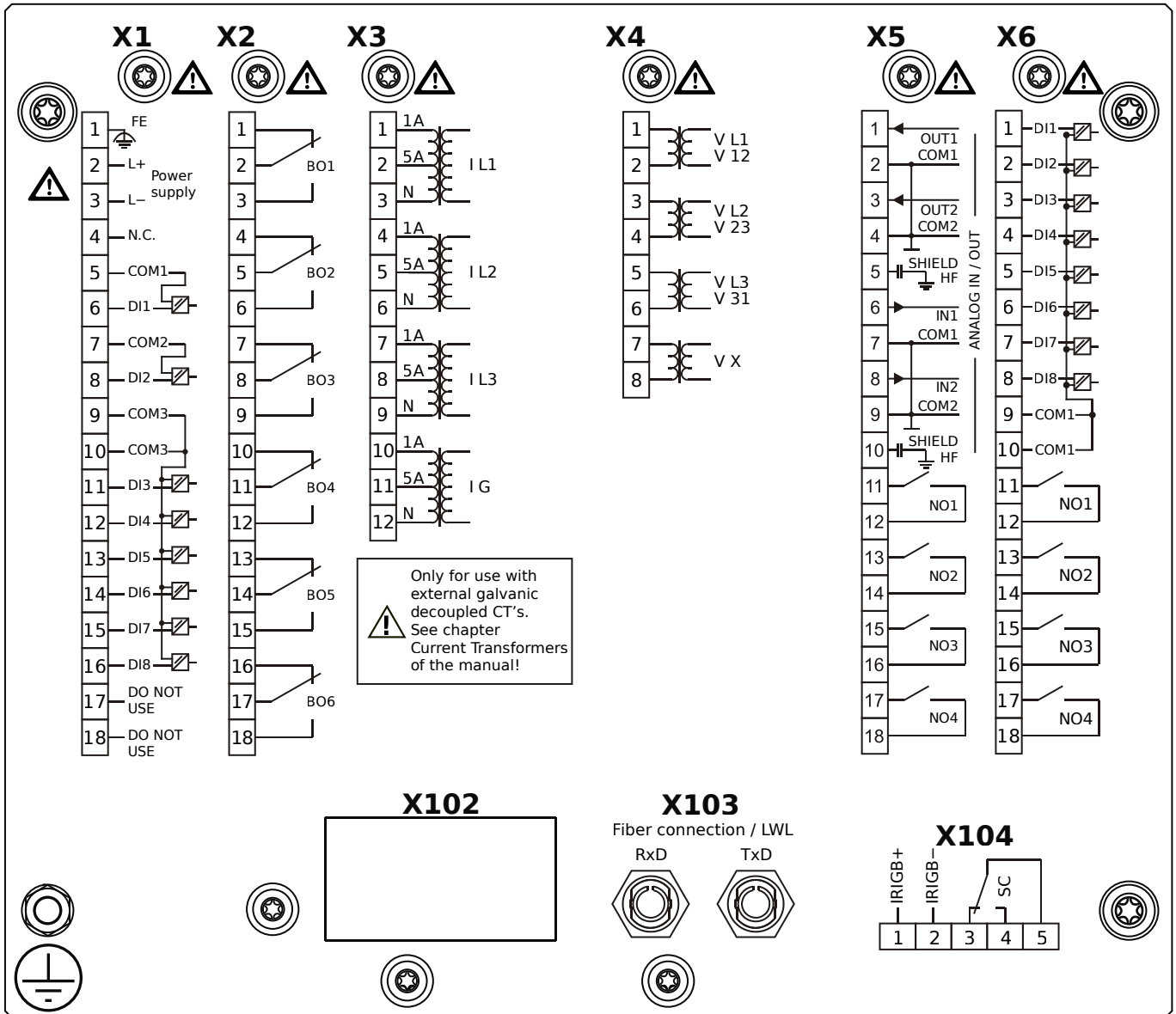

Housing B2, small display, 19" rack mounting

- + Conformal Coating (for installations in harsh environment)

- X1** – DI8-X1: Wide-range power supply unit, incl. 2 non-grouped digital inputs and 6 grouped digital inputs
- X2** – OR6: Assembly Group with 6 Output Relays (Changeover / Form C)
- X3** – TI: Standard current measuring card
- X4** – TU: Card with 4 voltage transformer measuring inputs (0 ... 800 VAC, under UL: 0 ... 600 VAC)
- X5** – AnIO2-OR4: Assembly Group with 2 Analog Inputs, 2 Analog Outputs and 4 Output Relays
- X6** – DI8-OR4: Assembly Group with 8 Digital Inputs and 4 Output Relays (NO / Form A)
- X103** – Modbus RTU / IEC 60870-5-103 / DNP3.0 RTU, Fiber optics interface, ST Connector
- X104** – IRIG-B00X, incl. System Contact (Supervision Contact)

MRA4-2F0BGA

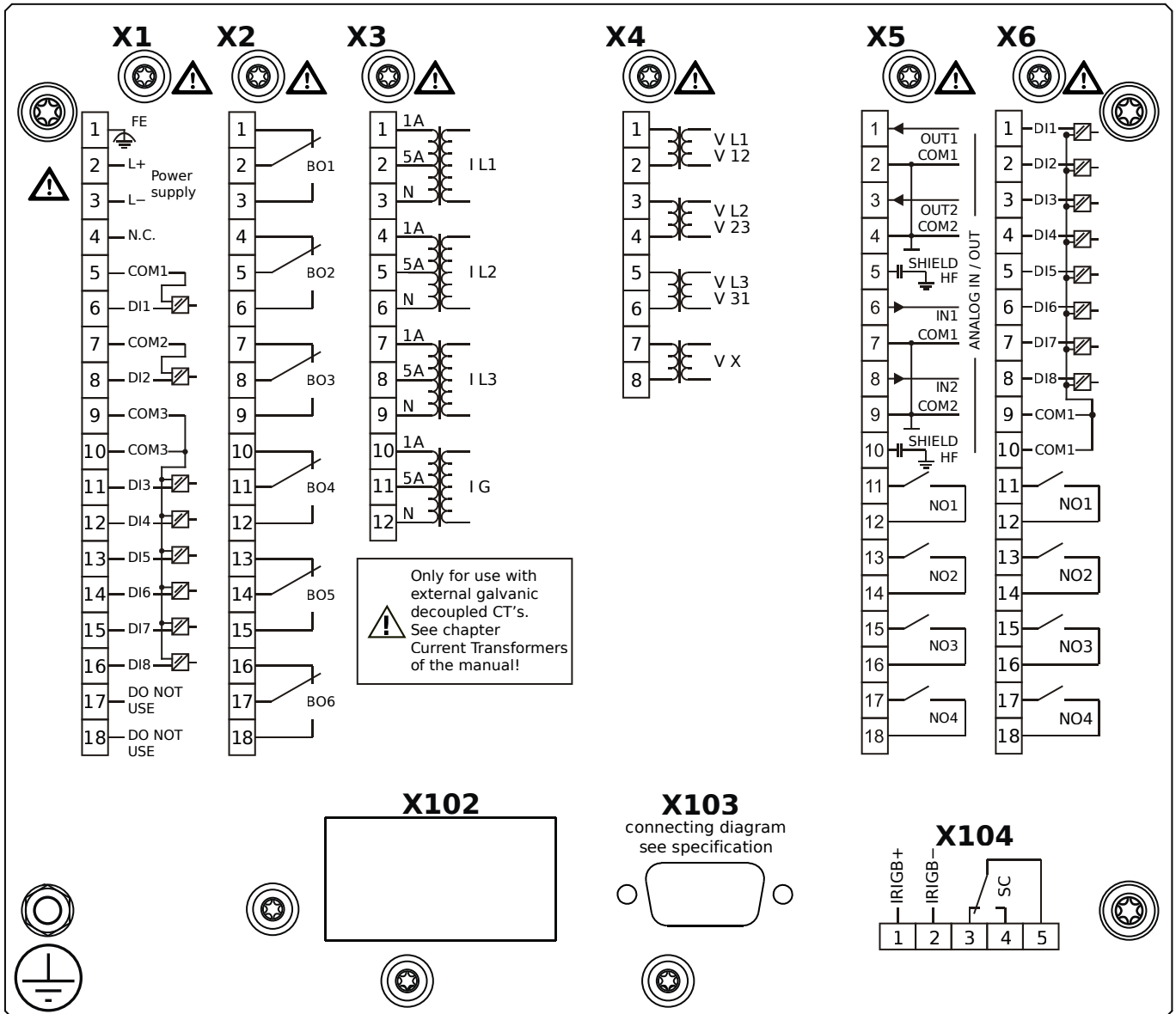

Housing B2, small display, 19" rack mounting

- X1** – DI8-X1: Wide-range power supply unit, incl. 2 non-grouped digital inputs and 6 grouped digital inputs
- X2** – OR6: Assembly Group with 6 Output Relays (Changeover / Form C)
- X3** – TI: Standard current measuring card
- X4** – TU: Card with 4 voltage transformer measuring inputs (0 ... 800 VAC, under UL: 0 ... 600 VAC)
- X5** – AnIO2-OR4: Assembly Group with 2 Analog Inputs, 2 Analog Outputs and 4 Output Relays
- X6** – DI8-OR4: Assembly Group with 8 Digital Inputs and 4 Output Relays (NO / Form A)
- X103** – Modbus RTU / IEC 60870-5-103 / DNP3.0 RTU, RS485, D-SUB
- X104** – IRIG-B00X, incl. System Contact (Supervision Contact)

MRA4-2F0BGB

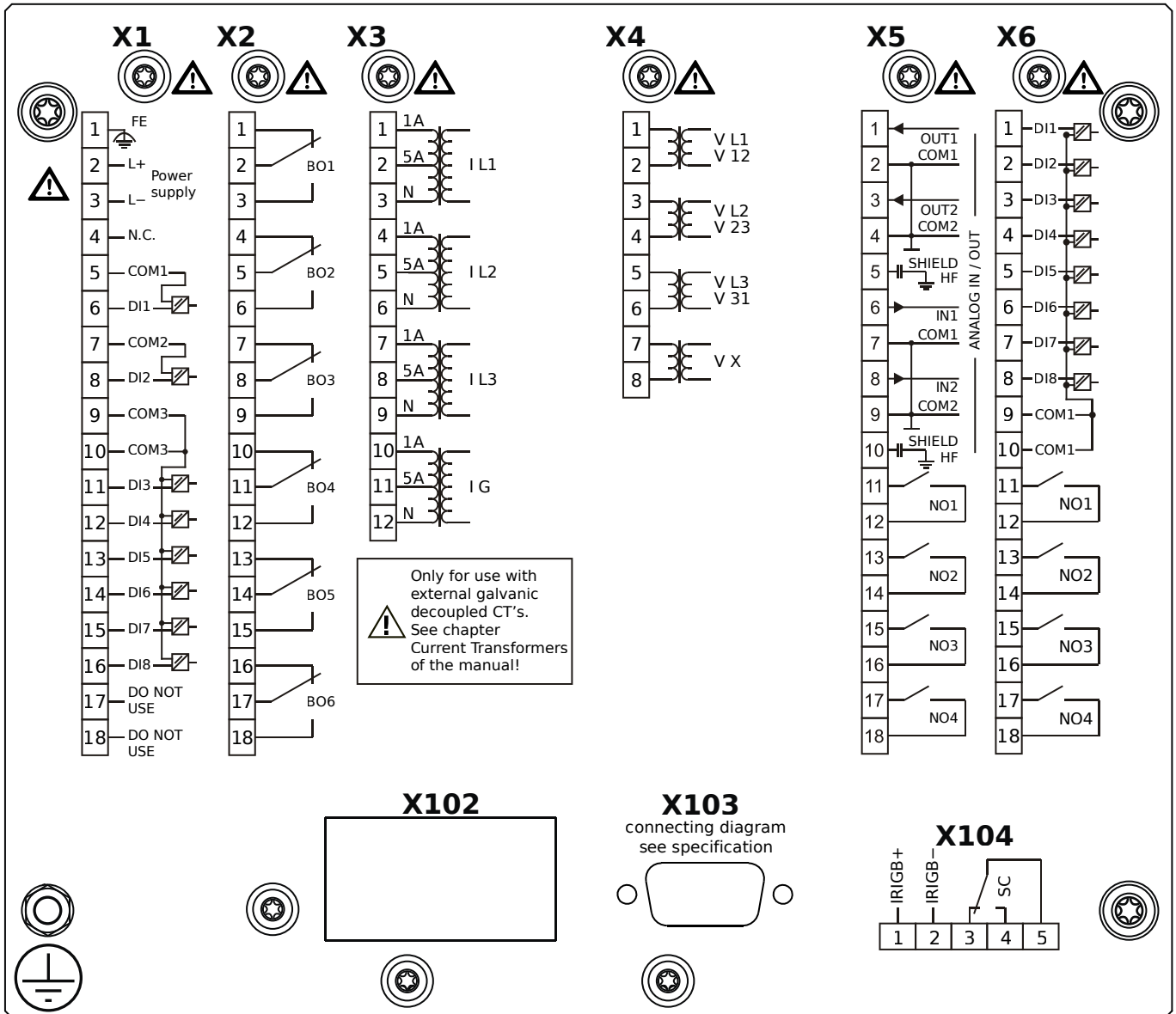

Housing B2, small display, 19" rack mounting

+ Conformal Coating (for installations in harsh environment)

- X1** – DI8-X1: Wide-range power supply unit, incl. 2 non-grouped digital inputs and 6 grouped digital inputs
- X2** – OR6: Assembly Group with 6 Output Relays (Changeover / Form C)
- X3** – TI: Standard current measuring card
- X4** – TU: Card with 4 voltage transformer measuring inputs (0 ... 800 VAC, under UL: 0 ... 600 VAC)
- X5** – AnIO2-OR4: Assembly Group with 2 Analog Inputs, 2 Analog Outputs and 4 Output Relays
- X6** – DI8-OR4: Assembly Group with 8 Digital Inputs and 4 Output Relays (NO / Form A)
- X103** – Modbus RTU / IEC 60870-5-103 / DNP3.0 RTU, RS485, D-SUB
- X104** – IRIG-B00X, incl. System Contact (Supervision Contact)

MRA4-2F0BHA

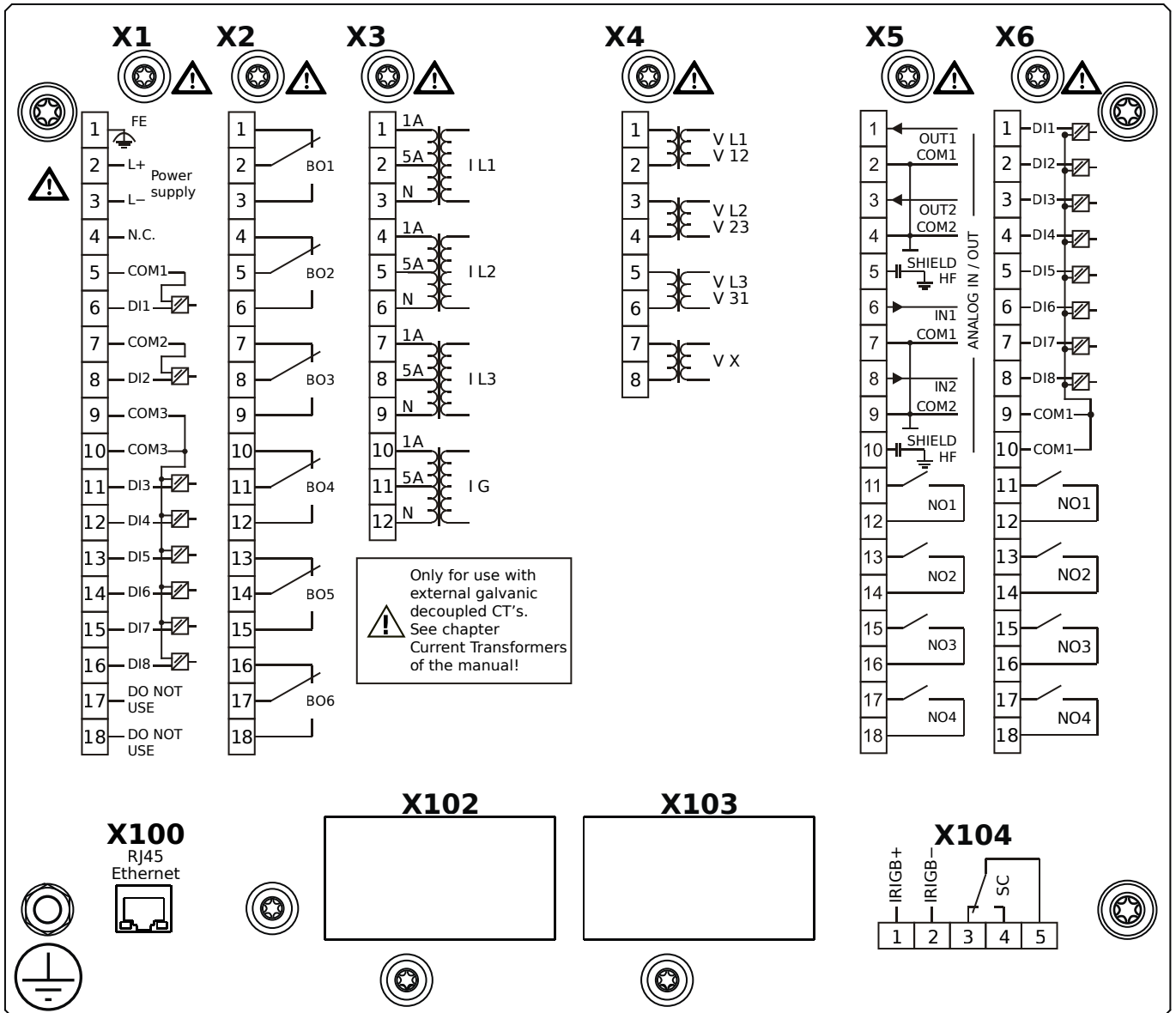

Housing B2, small display, 19" rack mounting

- X1** – DI8-X1: Wide-range power supply unit, incl. 2 non-grouped digital inputs and 6 grouped digital inputs
- X2** – OR6: Assembly Group with 6 Output Relays (Changeover / Form C)
- X3** – TI: Standard current measuring card
- X4** – TU: Card with 4 voltage transformer measuring inputs (0 ... 800 VAC, under UL: 0 ... 600 VAC)
- X5** – AnIO2-OR4: Assembly Group with 2 Analog Inputs, 2 Analog Outputs and 4 Output Relays
- X6** – DI8-OR4: Assembly Group with 8 Digital Inputs and 4 Output Relays (NO / Form A)
- X100** – IEC 61850 / Modbus TCP / DNP3.0 TCP/UDP, Ethernet interface, 100 Mbit/s, RJ45 (BASE100-FX)
- X104** – IRIG-B00X, incl. System Contact (Supervision Contact)

MRA4-2F0BHB

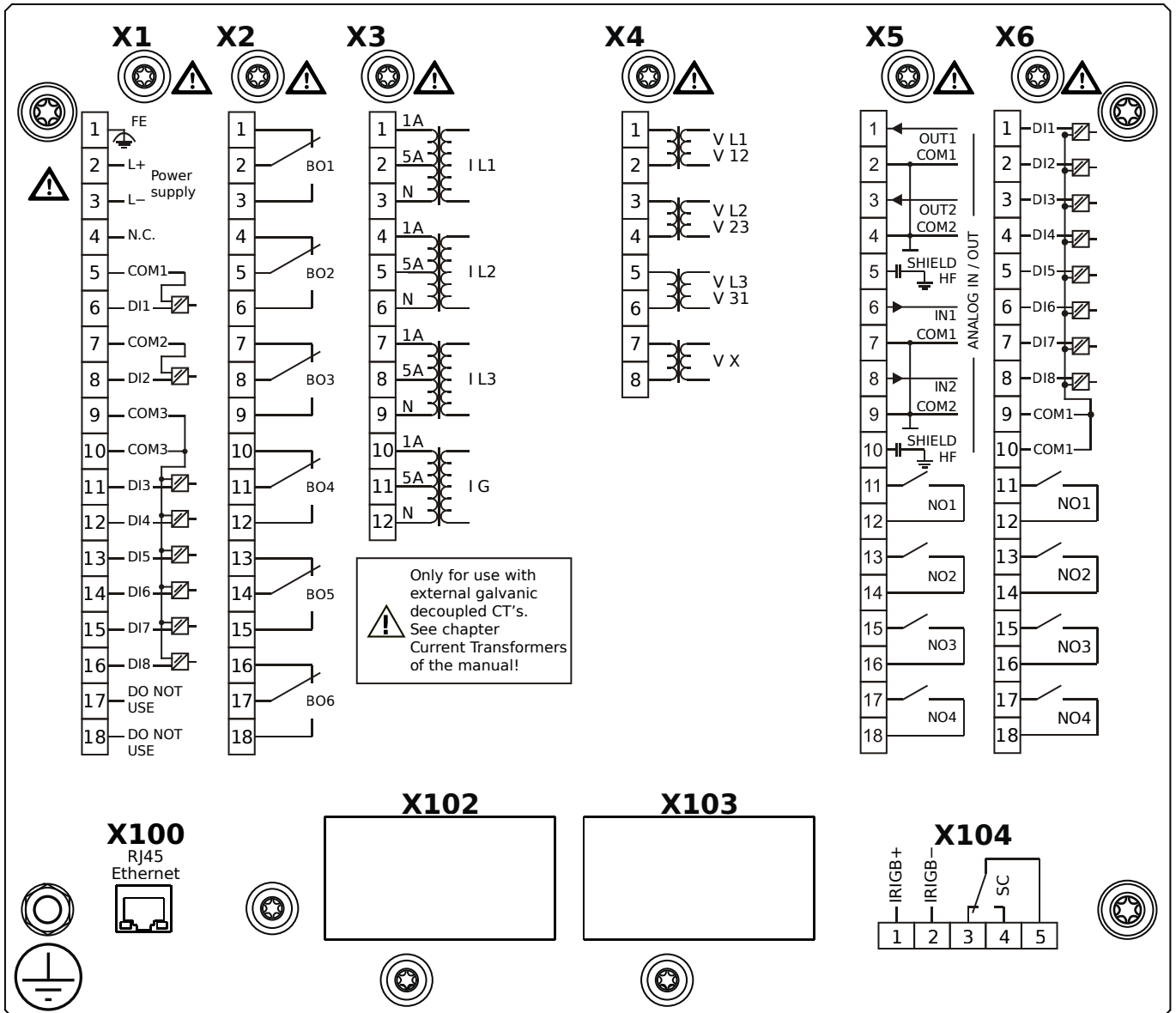

Housing B2, small display, 19" rack mounting

- + Conformal Coating (for installations in harsh environment)

- X1** – DI8-X1: Wide-range power supply unit, incl. 2 non-grouped digital inputs and 6 grouped digital inputs
- X2** – OR6: Assembly Group with 6 Output Relays (Changeover / Form C)
- X3** – TI: Standard current measuring card
- X4** – TU: Card with 4 voltage transformer measuring inputs (0 ... 800 VAC, under UL: 0 ... 600 VAC)
- X5** – AnIO2-OR4: Assembly Group with 2 Analog Inputs, 2 Analog Outputs and 4 Output Relays
- X6** – DI8-OR4: Assembly Group with 8 Digital Inputs and 4 Output Relays (NO / Form A)
- X100** – IEC 61850 / Modbus TCP / DNP3.0 TCP/UDP, Ethernet interface, 100 Mbit/s, RJ45 (BASE100-FX)
- X104** – IRIG-B00X, incl. System Contact (Supervision Contact)

MRA4-2F0BIA

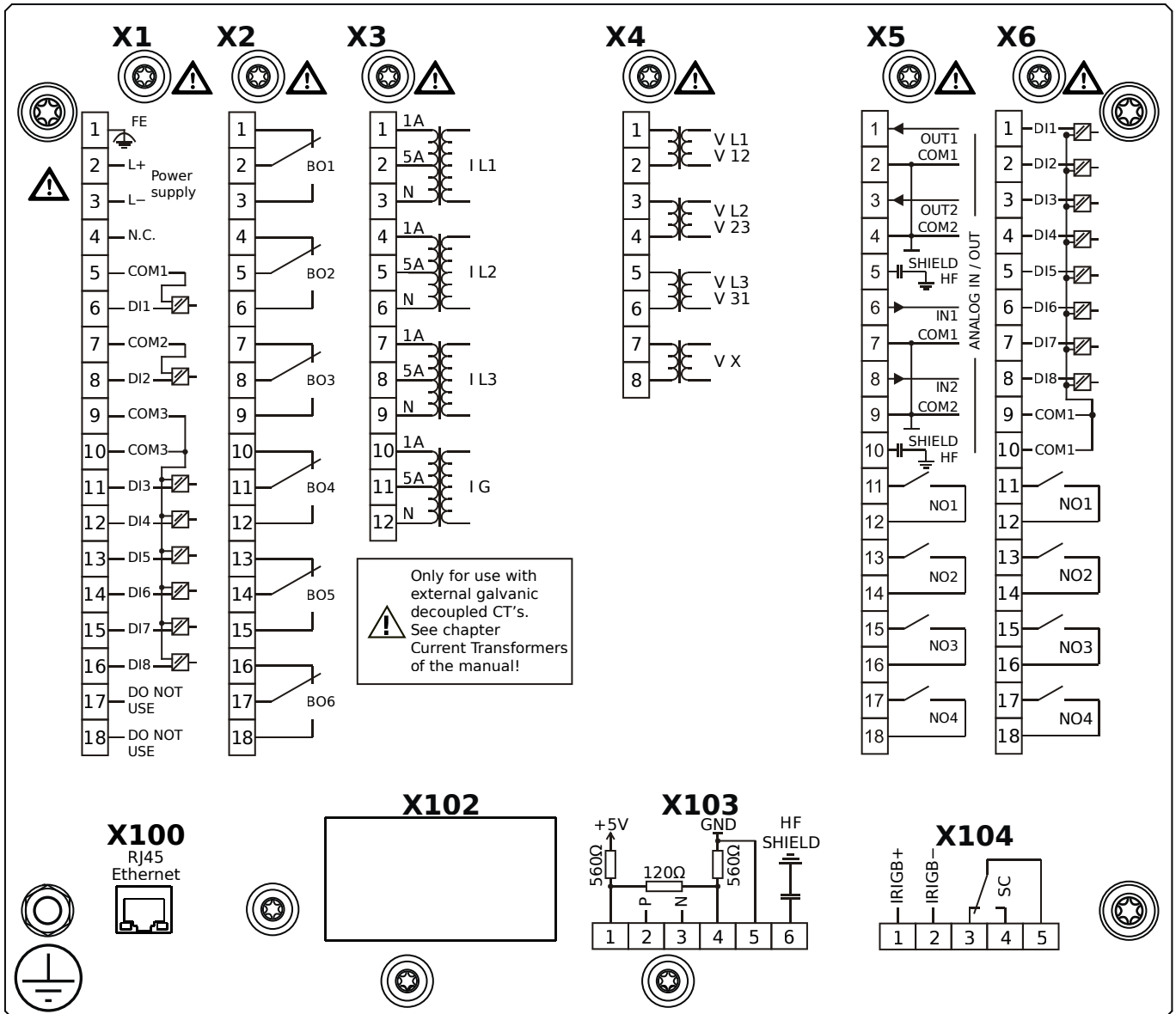

Housing B2, small display, 19" rack mounting

- X1** – DI8-X1: Wide-range power supply unit, incl. 2 non-grouped digital inputs and 6 grouped digital inputs
- X2** – OR6: Assembly Group with 6 Output Relays (Changeover / Form C)
- X3** – TI: Standard current measuring card
- X4** – TU: Card with 4 voltage transformer measuring inputs (0 ... 800 VAC, under UL: 0 ... 600 VAC)
- X5** – AnIO2-OR4: Assembly Group with 2 Analog Inputs, 2 Analog Outputs and 4 Output Relays
- X6** – DI8-OR4: Assembly Group with 8 Digital Inputs and 4 Output Relays (NO / Form A)
- X100** – Modbus TCP / DNP3.0 TCP/UDP, Ethernet interface, 100 Mbit/s, RJ45 (BASE100-FX)
- X103** – IEC 60870-5-103 / Modbus RTU / DNP3.0 RTU, RS485, Terminals
- X104** – IRIG-B00X, incl. System Contact (Supervision Contact)

MRA4-2F0BIB

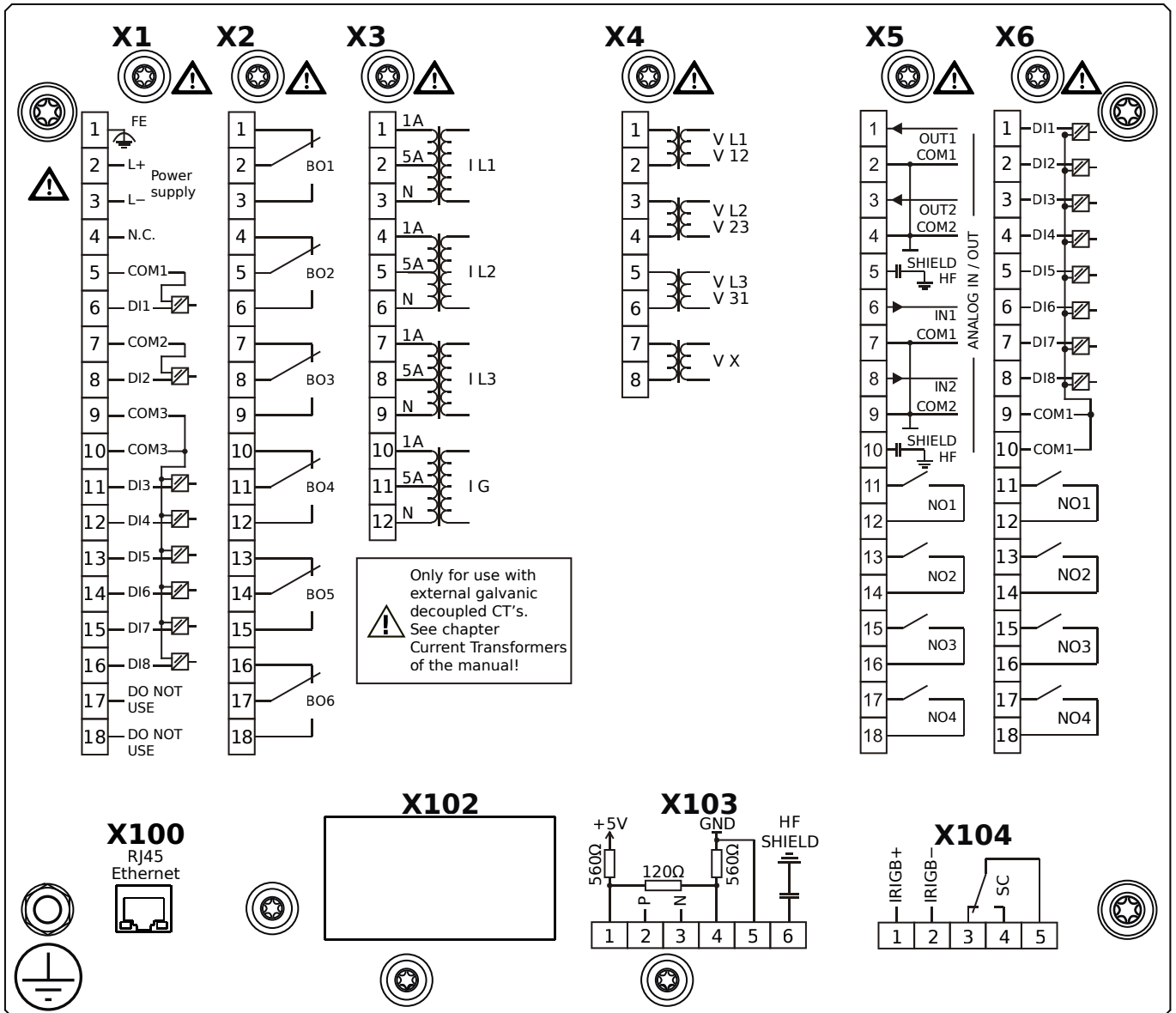

Housing B2, small display, 19" rack mounting

+ Conformal Coating (for installations in harsh environment)

- X1** – DI8-X1: Wide-range power supply unit, incl. 2 non-grouped digital inputs and 6 grouped digital inputs
- X2** – OR6: Assembly Group with 6 Output Relays (Changeover / Form C)
- X3** – TI: Standard current measuring card
- X4** – TU: Card with 4 voltage transformer measuring inputs (0 ... 800 VAC, under UL: 0 ... 600 VAC)
- X5** – AnIO2-OR4: Assembly Group with 2 Analog Inputs, 2 Analog Outputs and 4 Output Relays
- X6** – DI8-OR4: Assembly Group with 8 Digital Inputs and 4 Output Relays (NO / Form A)
- X100** – Modbus TCP / DNP3.0 TCP/UDP, Ethernet interface, 100 Mbit/s, RJ45 (BASE100-FX)
- X103** – IEC 60870-5-103 / Modbus RTU / DNP3.0 RTU, RS485, Terminals
- X104** – IRIG-B00X, incl. System Contact (Supervision Contact)

MRA4-2F0BKA

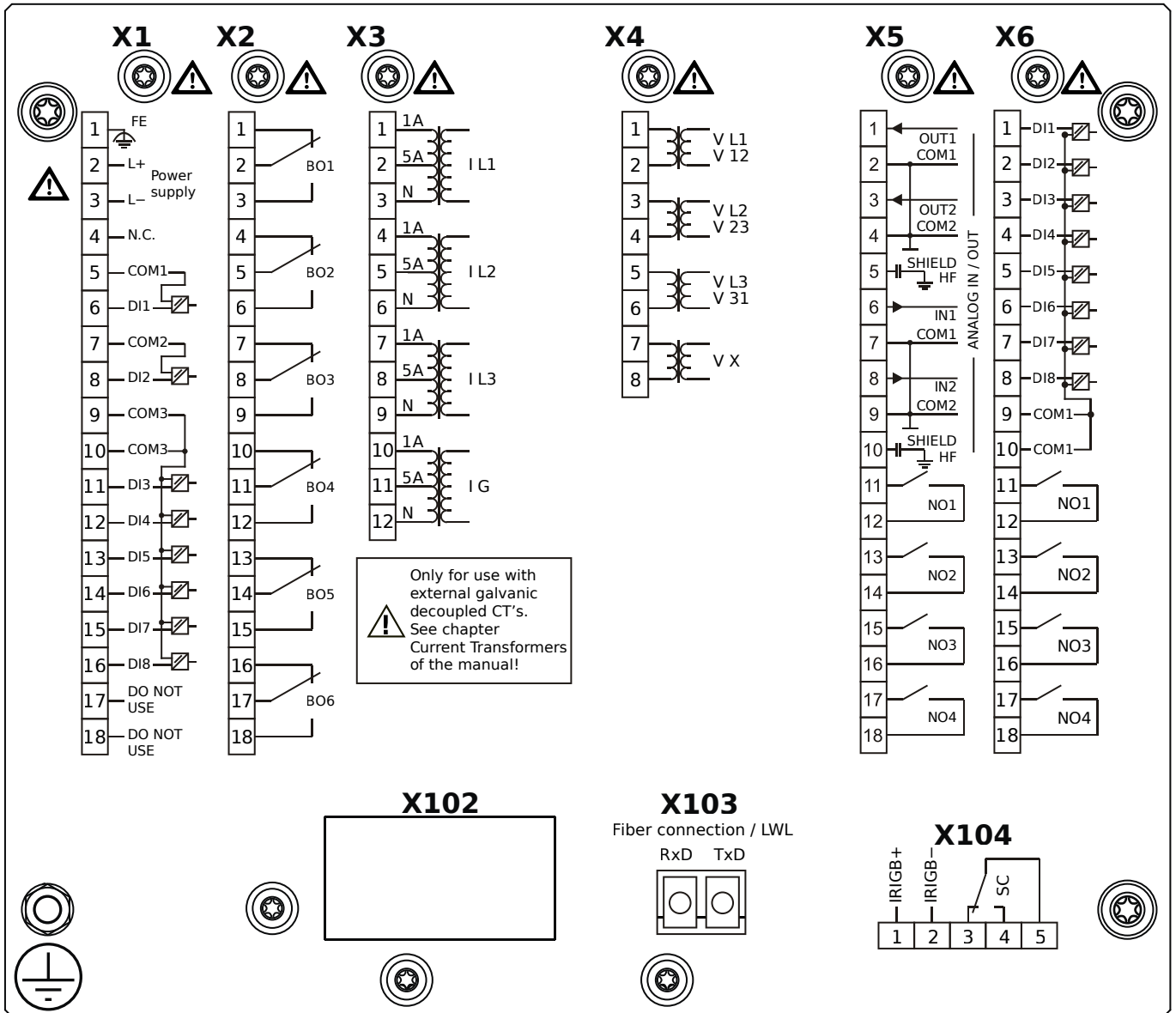

Housing B2, small display, 19" rack mounting

- X1** – DI8-X1: Wide-range power supply unit, incl. 2 non-grouped digital inputs and 6 grouped digital inputs
- X2** – OR6: Assembly Group with 6 Output Relays (Changeover / Form C)
- X3** – TI: Standard current measuring card
- X4** – TU: Card with 4 voltage transformer measuring inputs (0 ... 800 VAC, under UL: 0 ... 600 VAC)
- X5** – AnIO2-OR4: Assembly Group with 2 Analog Inputs, 2 Analog Outputs and 4 Output Relays
- X6** – DI8-OR4: Assembly Group with 8 Digital Inputs and 4 Output Relays (NO / Form A)
- X103** – IEC 61850 / Modbus TCP / DNP3.0 TCP/UDP, Fiber optics interface, LC Connector
- X104** – IRIG-B00X, incl. System Contact (Supervision Contact)

MRA4-2F0BKB

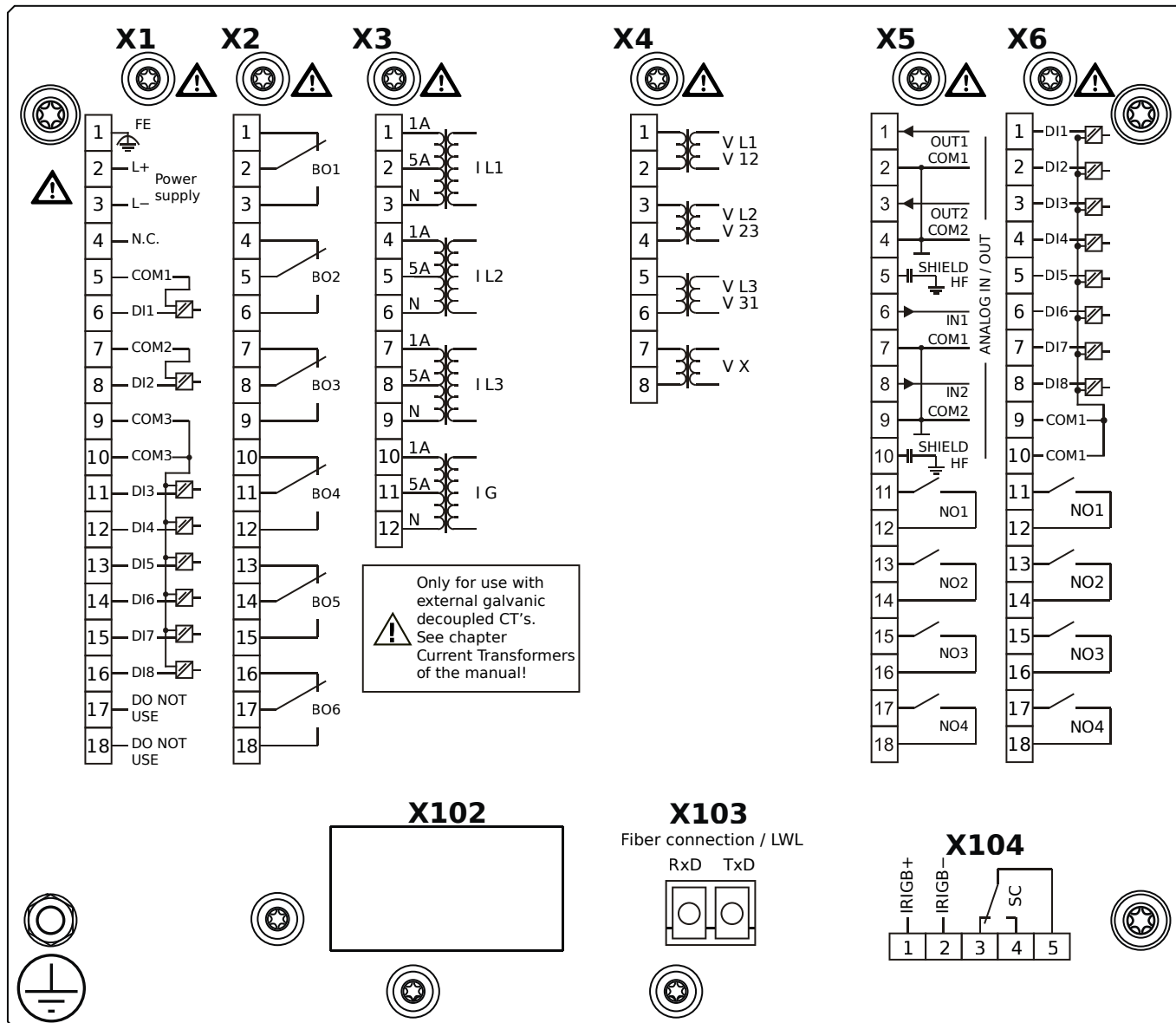

Housing B2, small display, 19" rack mounting

- + Conformal Coating (for installations in harsh environment)

- X1** – DI8-X1: Wide-range power supply unit, incl. 2 non-grouped digital inputs and 6 grouped digital inputs
- X2** – OR6: Assembly Group with 6 Output Relays (Changeover / Form C)
- X3** – TI: Standard current measuring card
- X4** – TU: Card with 4 voltage transformer measuring inputs (0 ... 800 VAC, under UL: 0 ... 600 VAC)
- X5** – AnIO2-OR4: Assembly Group with 2 Analog Inputs, 2 Analog Outputs and 4 Output Relays
- X6** – DI8-OR4: Assembly Group with 8 Digital Inputs and 4 Output Relays (NO / Form A)
- X103** – IEC 61850 / Modbus TCP / DNP3.0 TCP/UDP, Fiber optics interface, LC Connector
- X104** – IRIG-B00X, incl. System Contact (Supervision Contact)

MRA4-2F0BLA

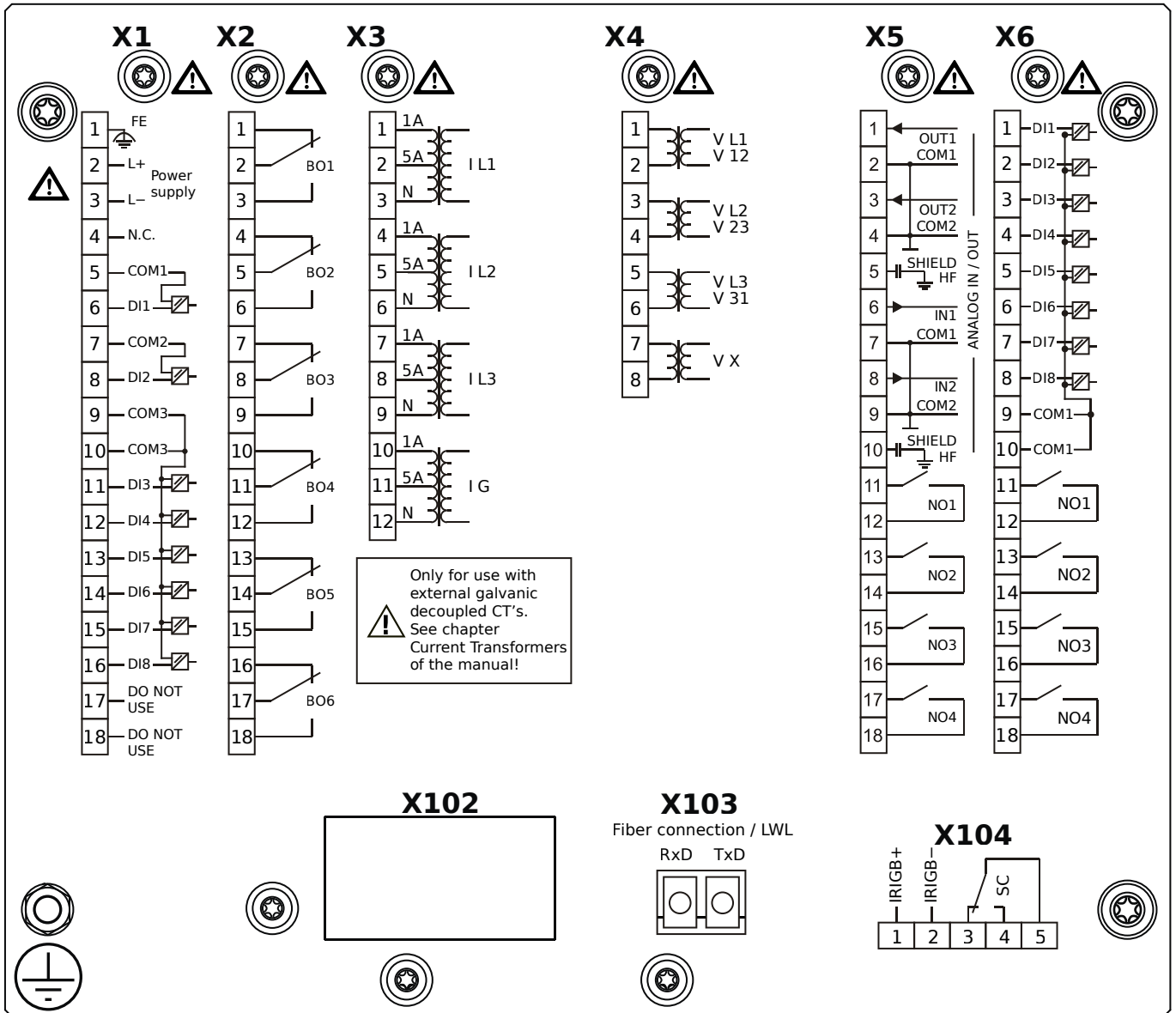

Housing B2, small display, 19" rack mounting

- X1** – DI8-X1: Wide-range power supply unit, incl. 2 non-grouped digital inputs and 6 grouped digital inputs
- X2** – OR6: Assembly Group with 6 Output Relays (Changeover / Form C)
- X3** – TI: Standard current measuring card
- X4** – TU: Card with 4 voltage transformer measuring inputs (0 ... 800 VAC, under UL: 0 ... 600 VAC)
- X5** – AnIO2-OR4: Assembly Group with 2 Analog Inputs, 2 Analog Outputs and 4 Output Relays
- X6** – DI8-OR4: Assembly Group with 8 Digital Inputs and 4 Output Relays (NO / Form A)
- X103** – Modbus TCP / DNP3.0 TCP/UDP, Fiber optics interface, LC Connector
- X104** – IRIG-B00X, incl. System Contact (Supervision Contact)

MRA4-2F0BLB

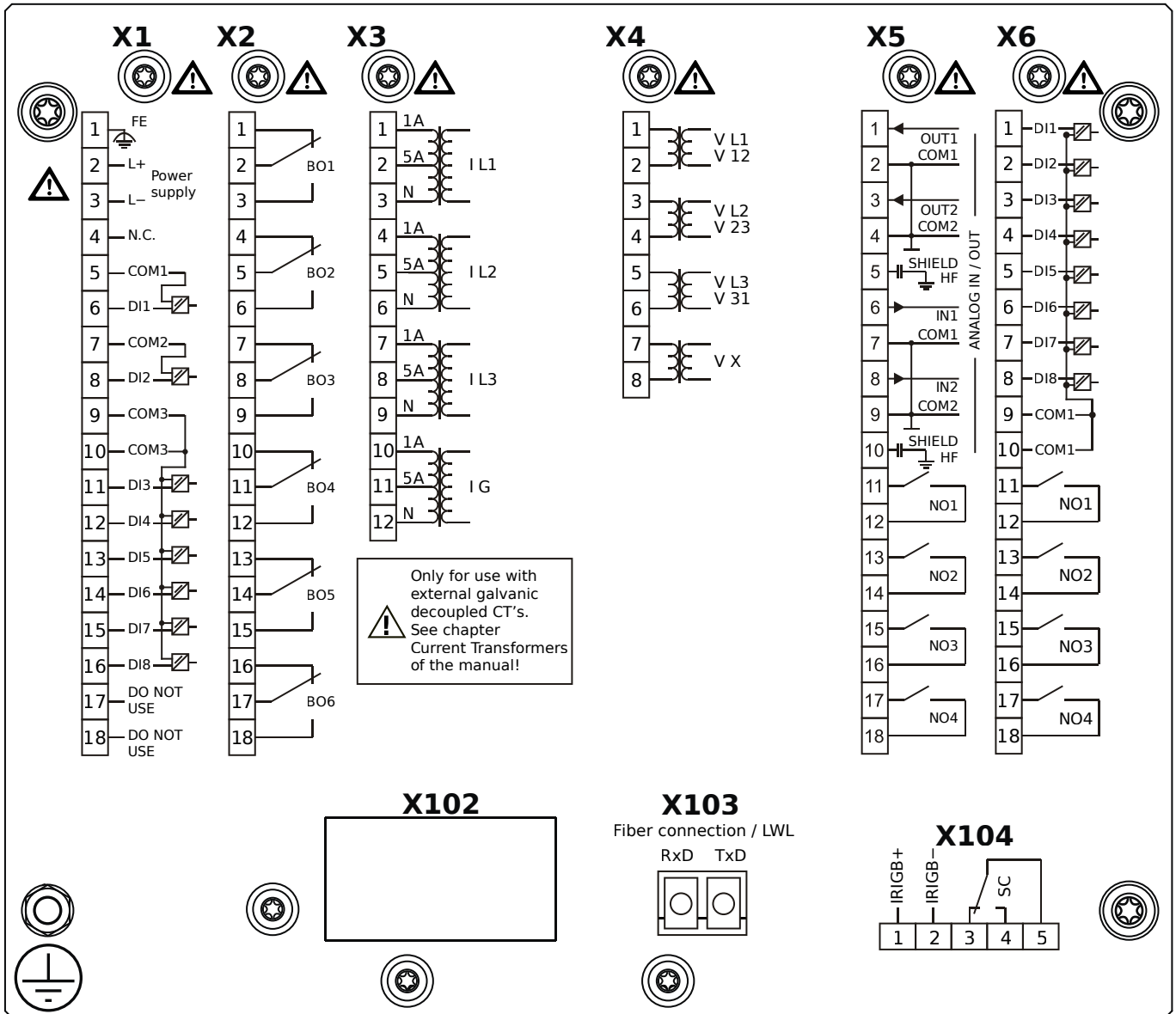

Housing B2, small display, 19" rack mounting

- + Conformal Coating (for installations in harsh environment)

- X1** – DI8-X1: Wide-range power supply unit, incl. 2 non-grouped digital inputs and 6 grouped digital inputs
- X2** – OR6: Assembly Group with 6 Output Relays (Changeover / Form C)
- X3** – TI: Standard current measuring card
- X4** – TU: Card with 4 voltage transformer measuring inputs (0 ... 800 VAC, under UL: 0 ... 600 VAC)
- X5** – AnIO2-OR4: Assembly Group with 2 Analog Inputs, 2 Analog Outputs and 4 Output Relays
- X6** – DI8-OR4: Assembly Group with 8 Digital Inputs and 4 Output Relays (NO / Form A)
- X103** – Modbus TCP / DNP3.0 TCP/UDP, Fiber optics interface, LC Connector
- X104** – IRIG-B00X, incl. System Contact (Supervision Contact)

MRA4-2F0BTA

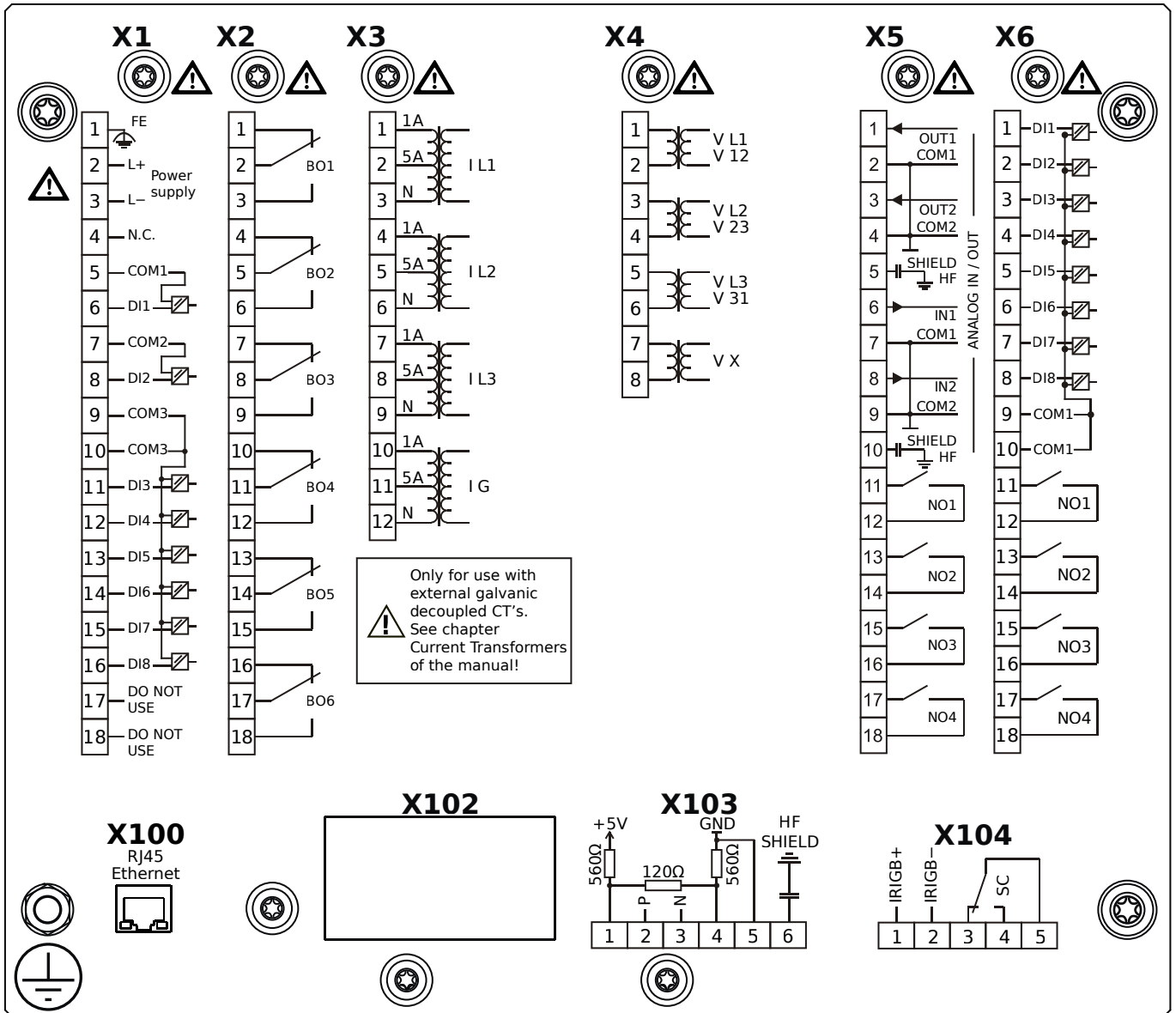

Housing B2, small display, 19" rack mounting

- X1** – DI8-X1: Wide-range power supply unit, incl. 2 non-grouped digital inputs and 6 grouped digital inputs
- X2** – OR6: Assembly Group with 6 Output Relays (Changeover / Form C)
- X3** – TI: Standard current measuring card
- X4** – TU: Card with 4 voltage transformer measuring inputs (0 ... 800 VAC, under UL: 0 ... 600 VAC)
- X5** – AnIO2-OR4: Assembly Group with 2 Analog Inputs, 2 Analog Outputs and 4 Output Relays
- X6** – DI8-OR4: Assembly Group with 8 Digital Inputs and 4 Output Relays (NO / Form A)
- X100** – IEC 61850 / Modbus TCP / DNP3.0 TCP/UDP, Ethernet interface, 100 Mbit/s, RJ45 (BASE100-FX)
- X103** – IEC 60870-5-103 / Modbus RTU / DNP3.0 RTU, RS485, Terminals
- X104** – IRIG-B00X, incl. System Contact (Supervision Contact)

MRA4-2F0BTB

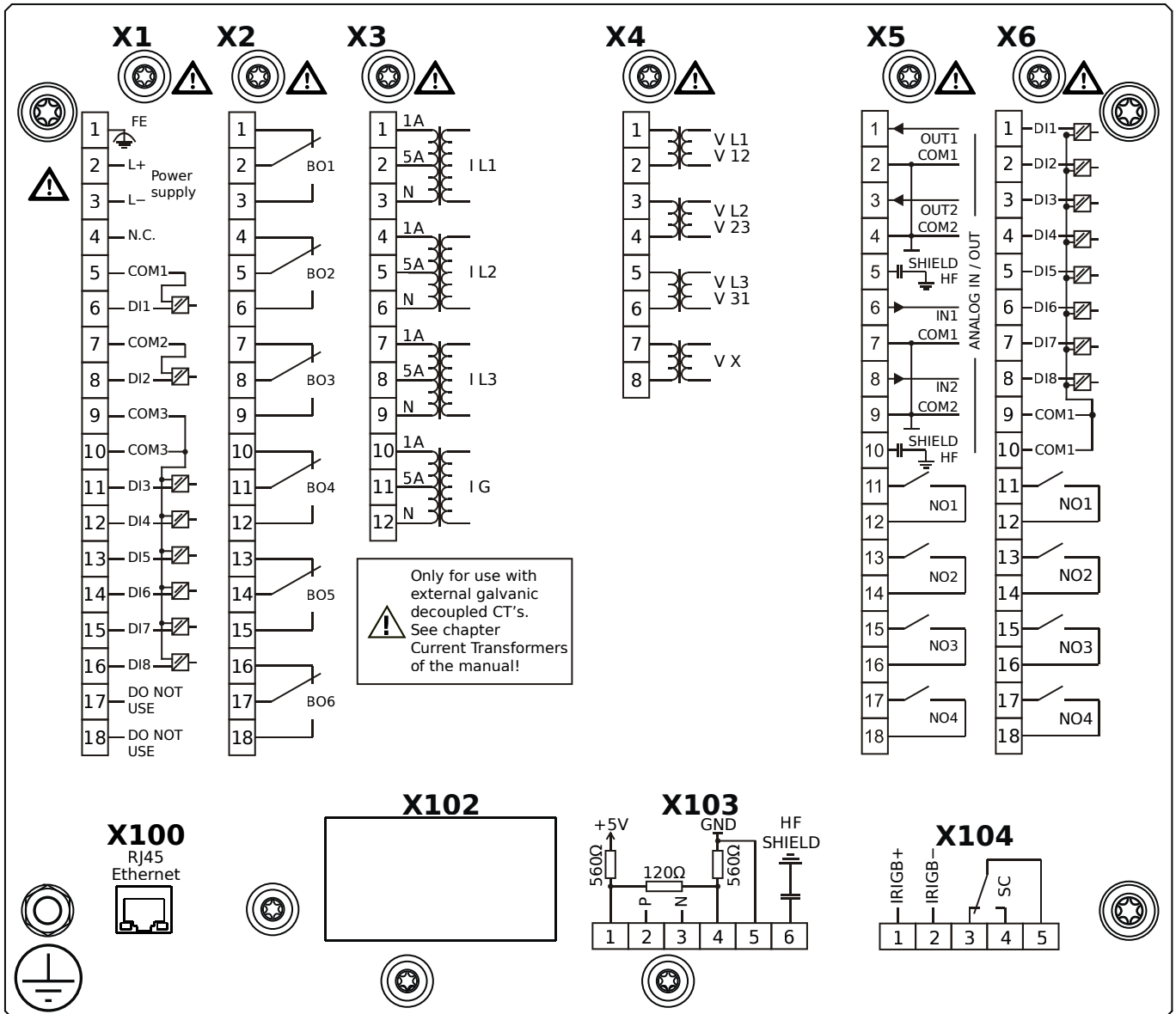

Housing B2, small display, 19" rack mounting

- + Conformal Coating (for installations in harsh environment)

- X1** – DI8-X1: Wide-range power supply unit, incl. 2 non-grouped digital inputs and 6 grouped digital inputs
- X2** – OR6: Assembly Group with 6 Output Relays (Changeover / Form C)
- X3** – TI: Standard current measuring card
- X4** – TU: Card with 4 voltage transformer measuring inputs (0 ... 800 VAC, under UL: 0 ... 600 VAC)
- X5** – AnIO2-OR4: Assembly Group with 2 Analog Inputs, 2 Analog Outputs and 4 Output Relays
- X6** – DI8-OR4: Assembly Group with 8 Digital Inputs and 4 Output Relays (NO / Form A)
- X100** – IEC 61850 / Modbus TCP / DNP3.0 TCP/UDP, Ethernet interface, 100 Mbit/s, RJ45 (BASE100-FX)
- X103** – IEC 60870-5-103 / Modbus RTU / DNP3.0 RTU, RS485, Terminals
- X104** – IRIG-B00X, incl. System Contact (Supervision Contact)

MRA4-2F1AAA

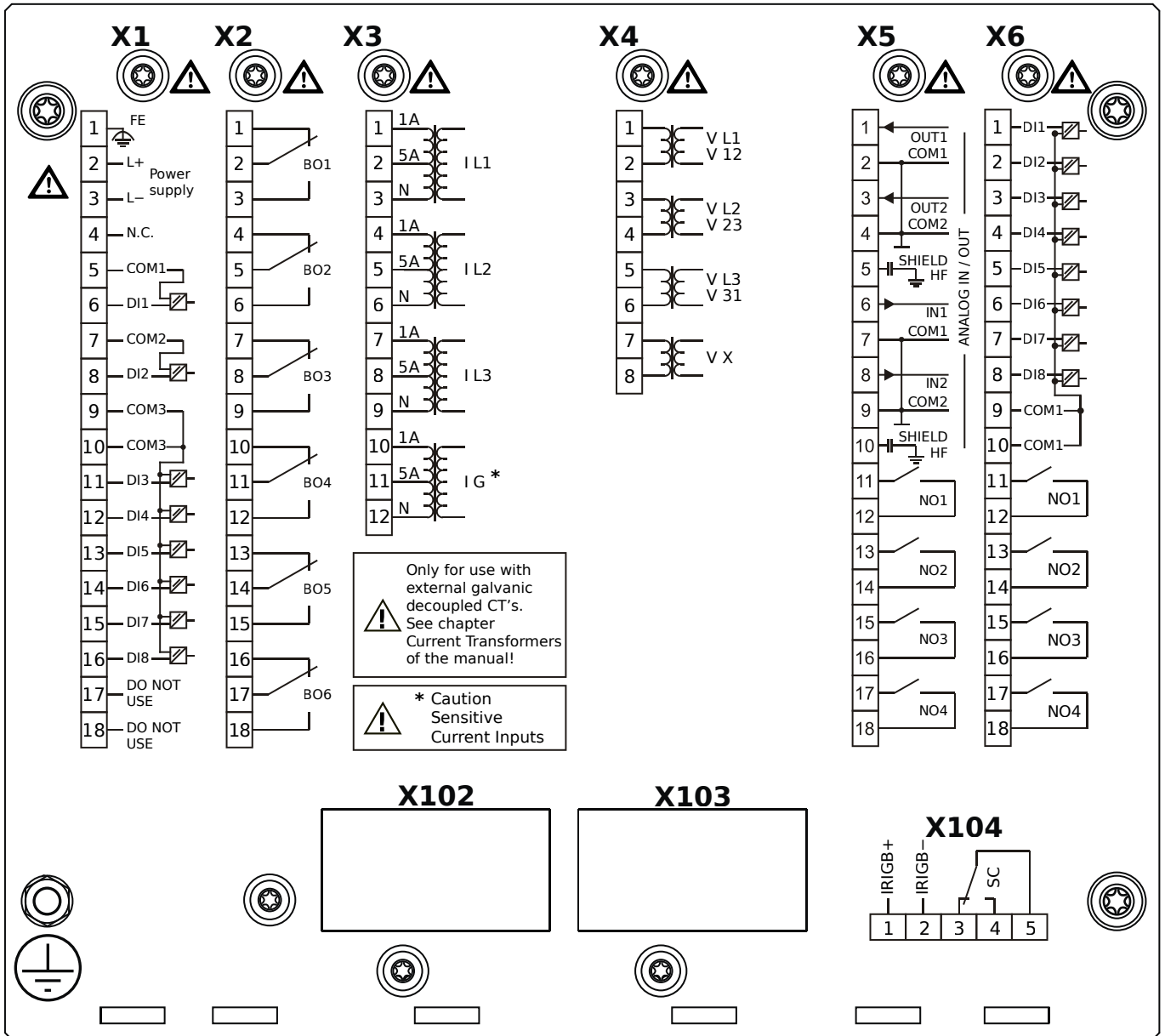

Housing B2, small display, door mounting

- X1** – DI8-X1: Wide-range power supply unit, incl. 2 non-grouped digital inputs and 6 grouped digital inputs
- X2** – OR6: Assembly Group with 6 Output Relays (Changeover / Form C)
- X3** – TIs: Standard phase current measuring card and sensitive ground current measuring
- X4** – TU: Card with 4 voltage transformer measuring inputs (0 ... 800 VAC, under UL: 0 ... 600 VAC)
- X5** – AnIO2-OR4: Assembly Group with 2 Analog Inputs, 2 Analog Outputs and 4 Output Relays
- X6** – DI8-OR4: Assembly Group with 8 Digital Inputs and 4 Output Relays (NO / Form A)
- X104** – IRIG-B00X, incl. System Contact (Supervision Contact)

MRA4-2F1AAB

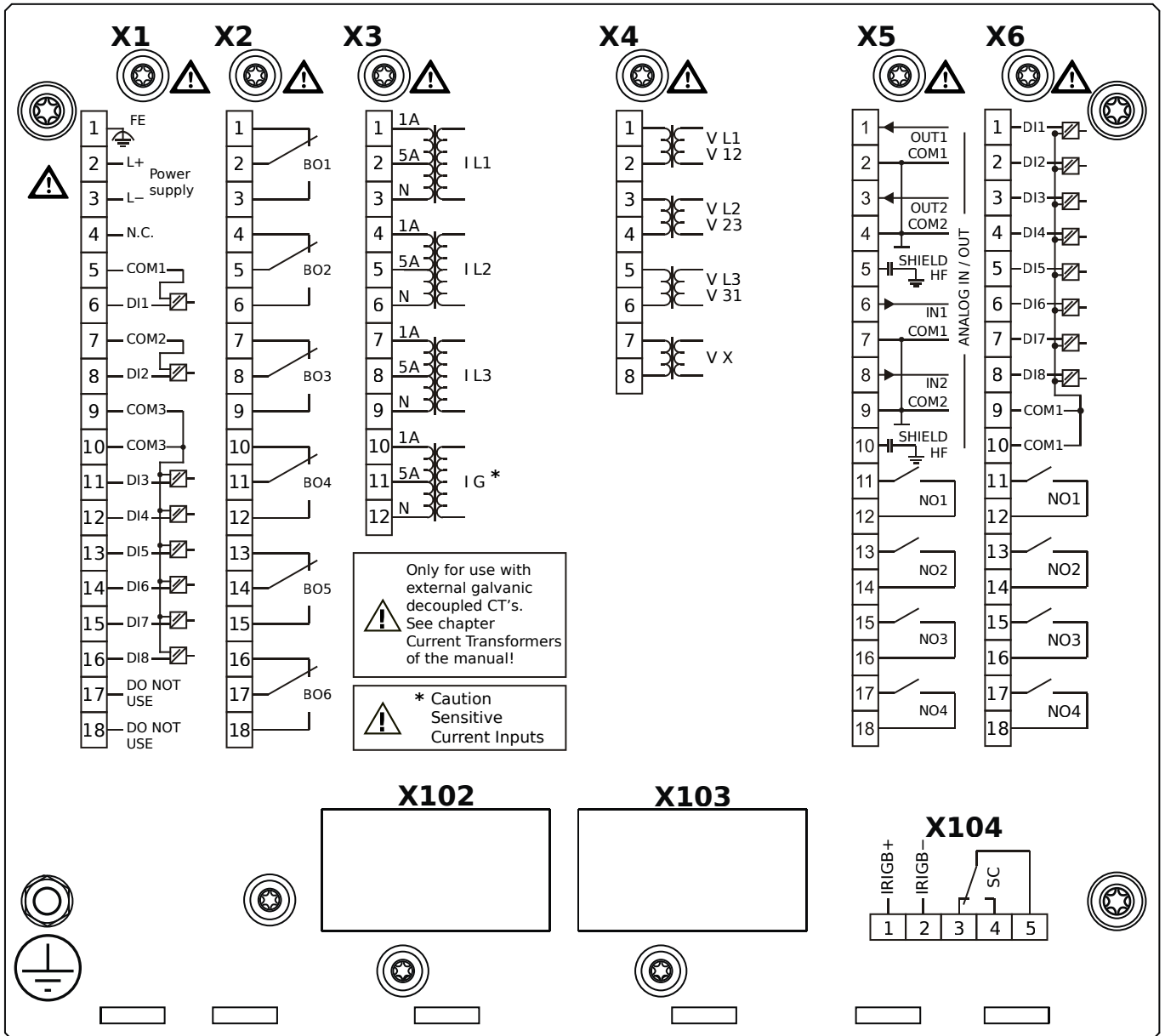

Housing B2, small display, door mounting

+ Conformal Coating (for installations in harsh environment)

- X1** – DI8-X1: Wide-range power supply unit, incl. 2 non-grouped digital inputs and 6 grouped digital inputs
- X2** – OR6: Assembly Group with 6 Output Relays (Changeover / Form C)
- X3** – TIs: Standard phase current measuring card and sensitive ground current measuring
- X4** – TU: Card with 4 voltage transformer measuring inputs (0 ... 800 VAC, under UL: 0 ... 600 VAC)
- X5** – AnIO2-OR4: Assembly Group with 2 Analog Inputs, 2 Analog Outputs and 4 Output Relays
- X6** – DI8-OR4: Assembly Group with 8 Digital Inputs and 4 Output Relays (NO / Form A)
- X104** – IRIG-B00X, incl. System Contact (Supervision Contact)

MRA4-2F1ABA

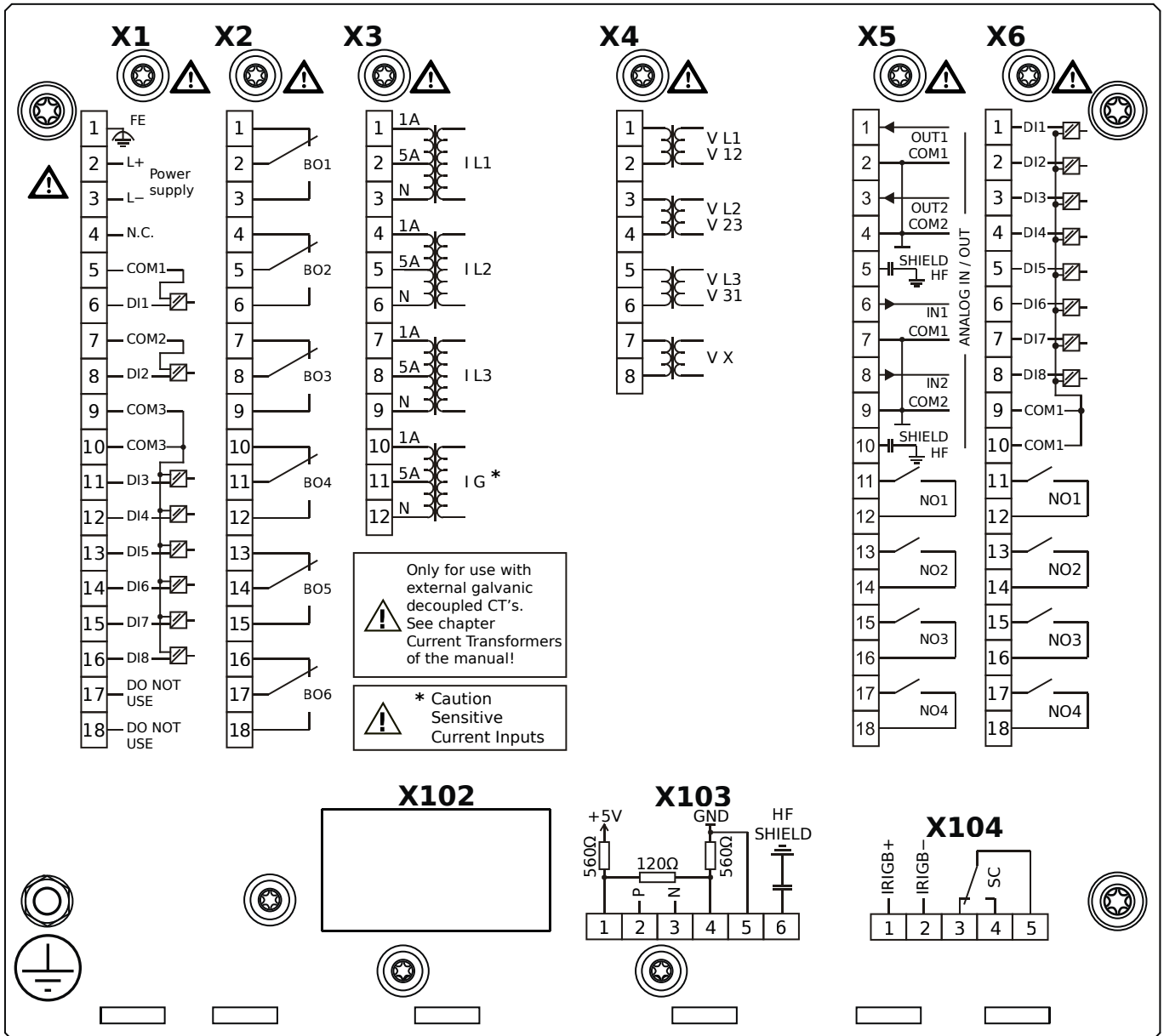

Housing B2, small display, door mounting

- X1** – DI8-X1: Wide-range power supply unit, incl. 2 non-grouped digital inputs and 6 grouped digital inputs
- X2** – OR6: Assembly Group with 6 Output Relays (Changeover / Form C)
- X3** – TIs: Standard phase current measuring card and sensitive ground current measuring
- X4** – TU: Card with 4 voltage transformer measuring inputs (0 ... 800 VAC, under UL: 0 ... 600 VAC)
- X5** – AnIO2-OR4: Assembly Group with 2 Analog Inputs, 2 Analog Outputs and 4 Output Relays
- X6** – DI8-OR4: Assembly Group with 8 Digital Inputs and 4 Output Relays (NO / Form A)
- X103** – Modbus RTU / IEC 60870-5-103 / DNP3.0 RTU, RS485, Terminals
- X104** – IRIG-B00X, incl. System Contact (Supervision Contact)

MRA4-2F1ABB

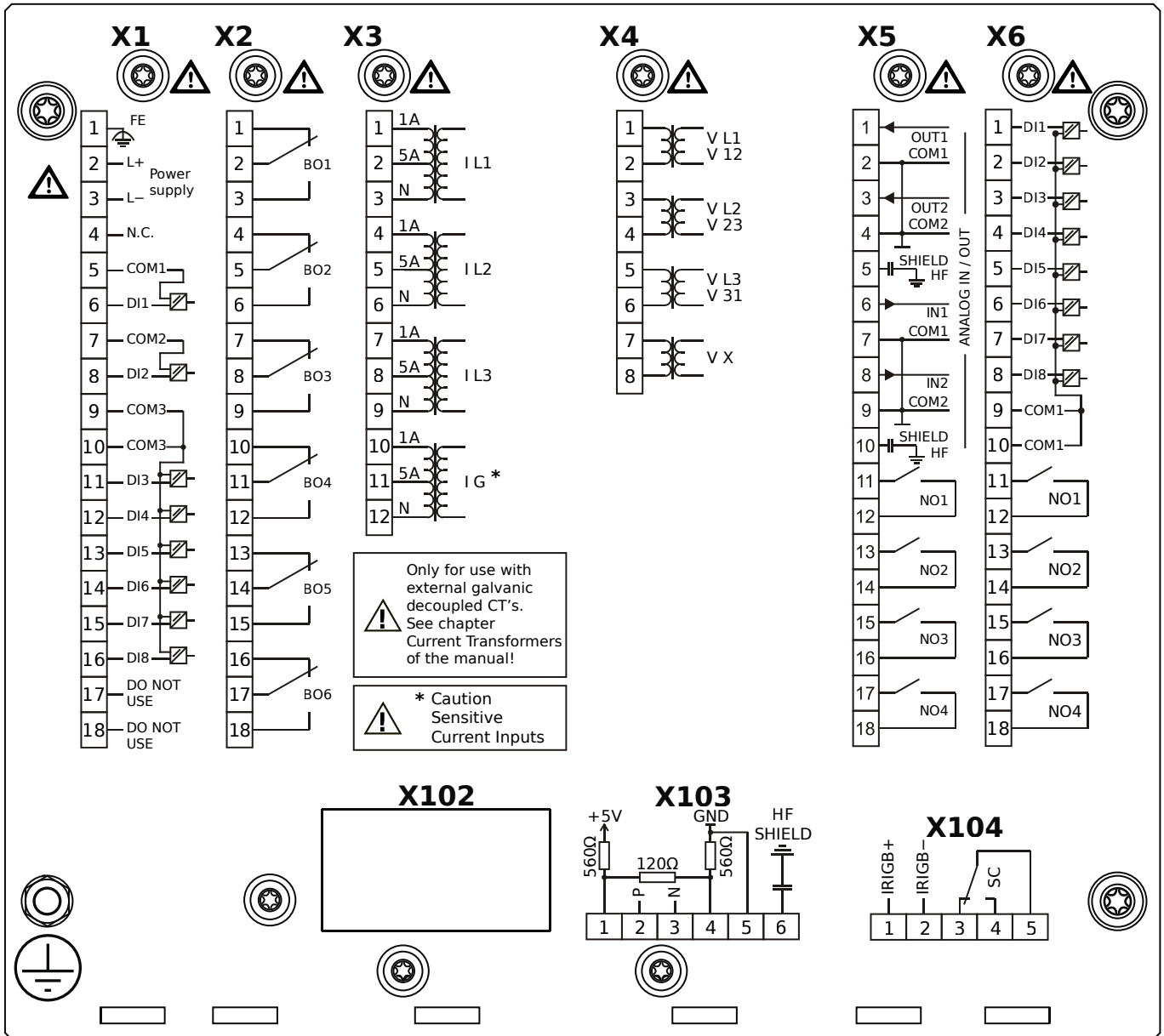

Housing B2, small display, door mounting

+ Conformal Coating (for installations in harsh environment)

- X1** – DI8-X1: Wide-range power supply unit, incl. 2 non-grouped digital inputs and 6 grouped digital inputs
- X2** – OR6: Assembly Group with 6 Output Relays (Changeover / Form C)
- X3** – TIs: Standard phase current measuring card and sensitive ground current measuring
- X4** – TU: Card with 4 voltage transformer measuring inputs (0 ... 800 VAC, under UL: 0 ... 600 VAC)
- X5** – AnIO2-OR4: Assembly Group with 2 Analog Inputs, 2 Analog Outputs and 4 Output Relays
- X6** – DI8-OR4: Assembly Group with 8 Digital Inputs and 4 Output Relays (NO / Form A)
- X103** – Modbus RTU / IEC 60870-5-103 / DNP3.0 RTU, RS485, Terminals
- X104** – IRIG-B00X, incl. System Contact (Supervision Contact)

MRA4-2F1ACA

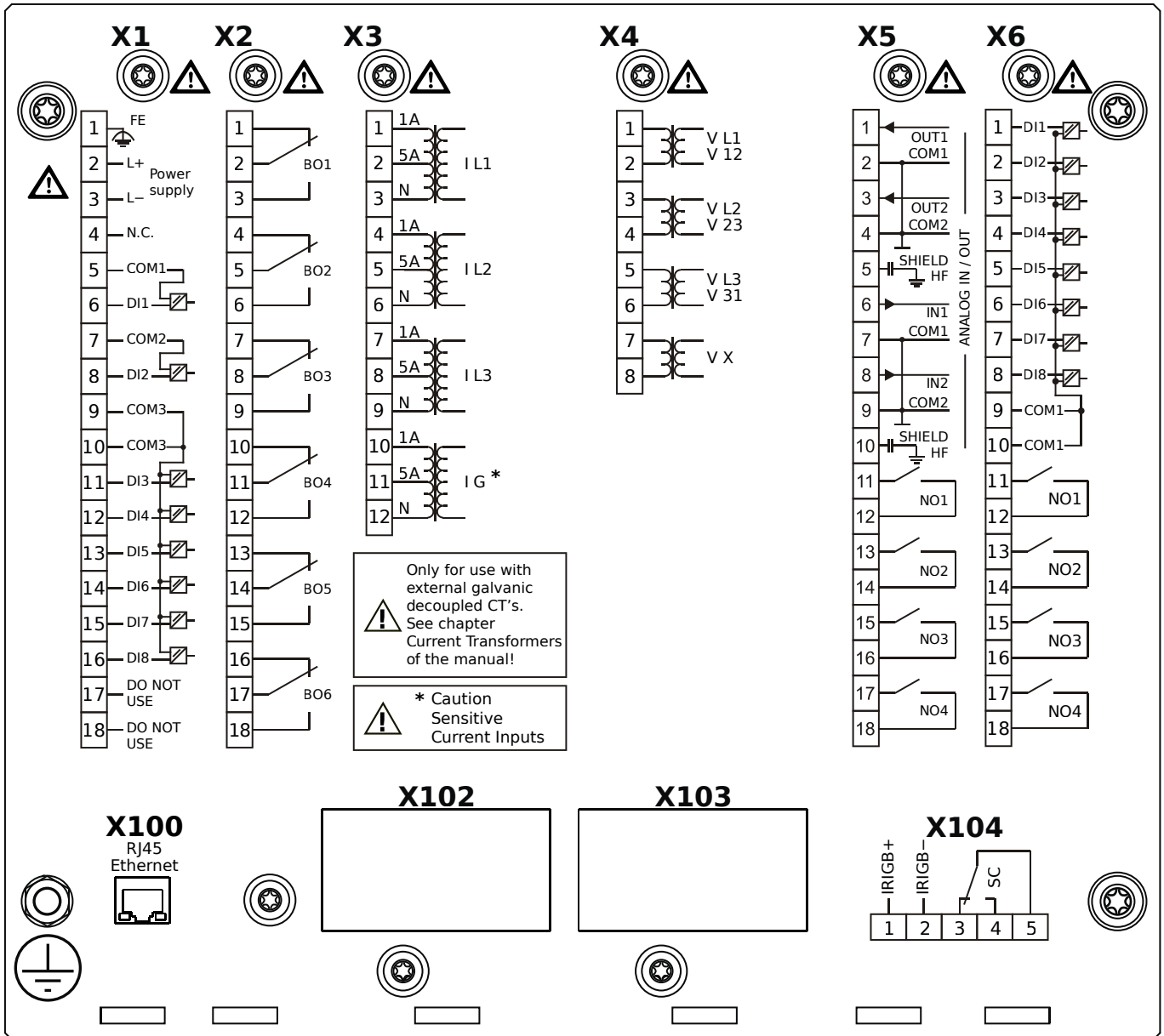

Housing B2, small display, door mounting

- X1** – DI8-X1: Wide-range power supply unit, incl. 2 non-grouped digital inputs and 6 grouped digital inputs
- X2** – OR6: Assembly Group with 6 Output Relays (Changeover / Form C)
- X3** – TIs: Standard phase current measuring card and sensitive ground current measuring
- X4** – TU: Card with 4 voltage transformer measuring inputs (0 ... 800 VAC, under UL: 0 ... 600 VAC)
- X5** – AnIO2-OR4: Assembly Group with 2 Analog Inputs, 2 Analog Outputs and 4 Output Relays
- X6** – DI8-OR4: Assembly Group with 8 Digital Inputs and 4 Output Relays (NO / Form A)
- X100** – Modbus TCP / DNP3.0 TCP/UDP, Ethernet interface, 100 Mbit/s, RJ45 (BASE100-FX)
- X104** – IRIG-B00X, incl. System Contact (Supervision Contact)

MRA4-2F1ACB

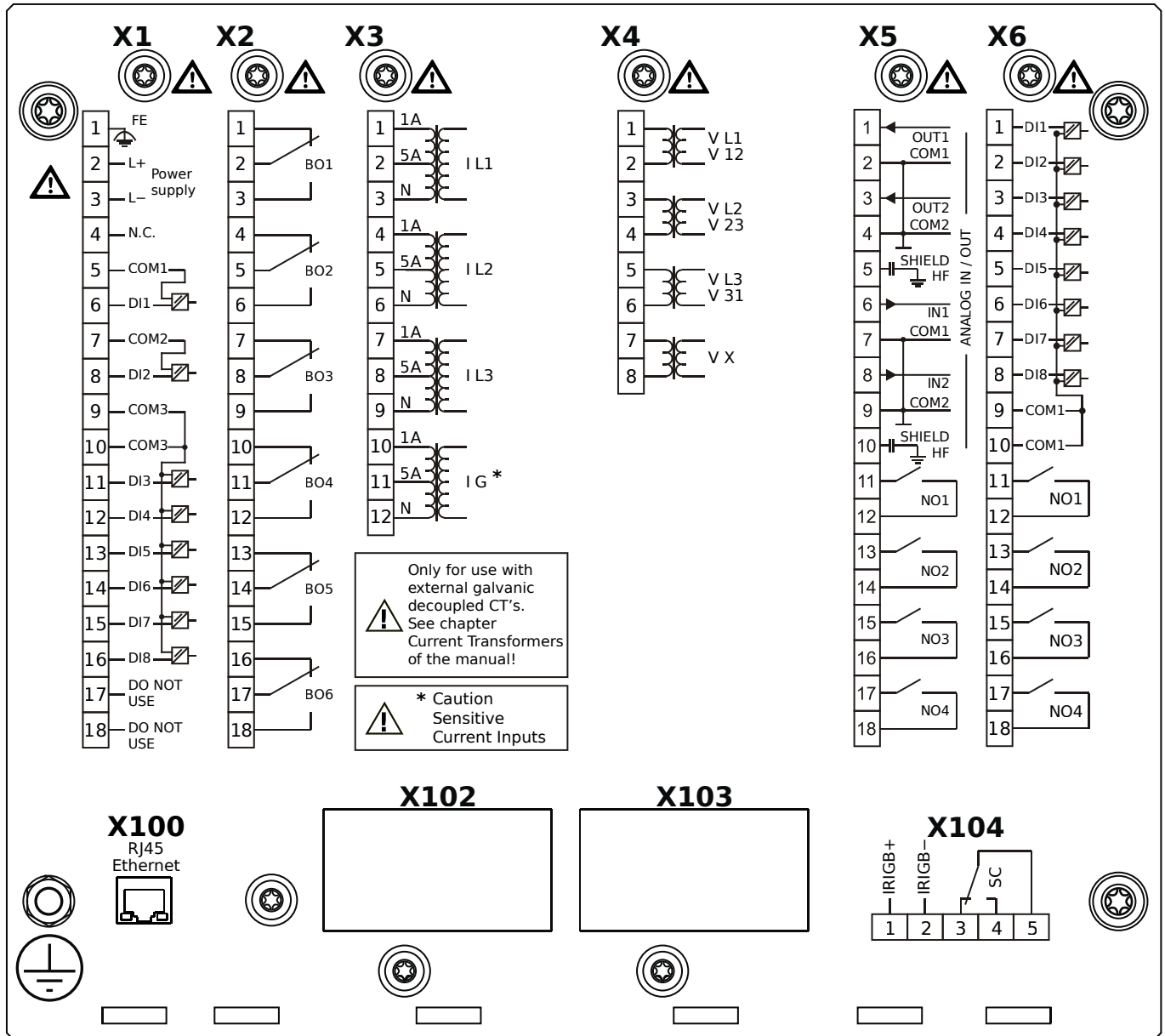

Housing B2, small display, door mounting

+ Conformal Coating (for installations in harsh environment)

- X1** – DI8-X1: Wide-range power supply unit, incl. 2 non-grouped digital inputs and 6 grouped digital inputs
- X2** – OR6: Assembly Group with 6 Output Relays (Changeover / Form C)
- X3** – TIs: Standard phase current measuring card and sensitive ground current measuring
- X4** – TU: Card with 4 voltage transformer measuring inputs (0 ... 800 VAC, under UL: 0 ... 600 VAC)
- X5** – AnIO2-OR4: Assembly Group with 2 Analog Inputs, 2 Analog Outputs and 4 Output Relays
- X6** – DI8-OR4: Assembly Group with 8 Digital Inputs and 4 Output Relays (NO / Form A)
- X100** – Modbus TCP / DNP3.0 TCP/UDP, Ethernet interface, 100 Mbit/s, RJ45 (BASE100-FX)
- X104** – IRIG-B00X, incl. System Contact (Supervision Contact)

MRA4-2F1ADA

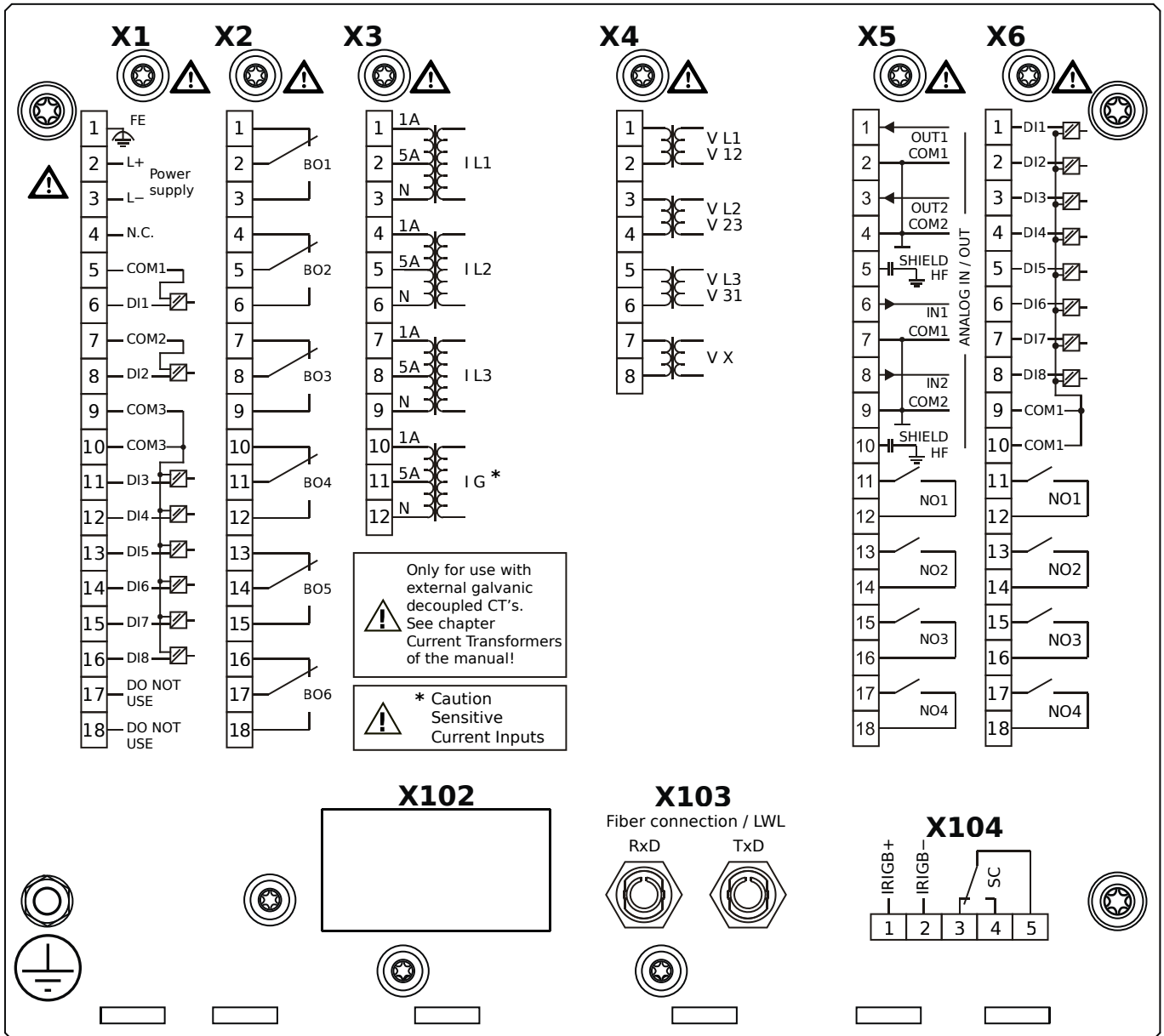

Housing B2, small display, door mounting

- X1** – DI8-X1: Wide-range power supply unit, incl. 2 non-grouped digital inputs and 6 grouped digital inputs
- X2** – OR6: Assembly Group with 6 Output Relays (Changeover / Form C)
- X3** – TIs: Standard phase current measuring card and sensitive ground current measuring
- X4** – TU: Card with 4 voltage transformer measuring inputs (0 ... 800 VAC, under UL: 0 ... 600 VAC)
- X5** – AnIO2-OR4: Assembly Group with 2 Analog Inputs, 2 Analog Outputs and 4 Output Relays
- X6** – DI8-OR4: Assembly Group with 8 Digital Inputs and 4 Output Relays (NO / Form A)
- X103** – Profibus-DP, Fiber optics interface, ST Connector
- X104** – IRIG-B00X, incl. System Contact (Supervision Contact)

MRA4-2F1ADB

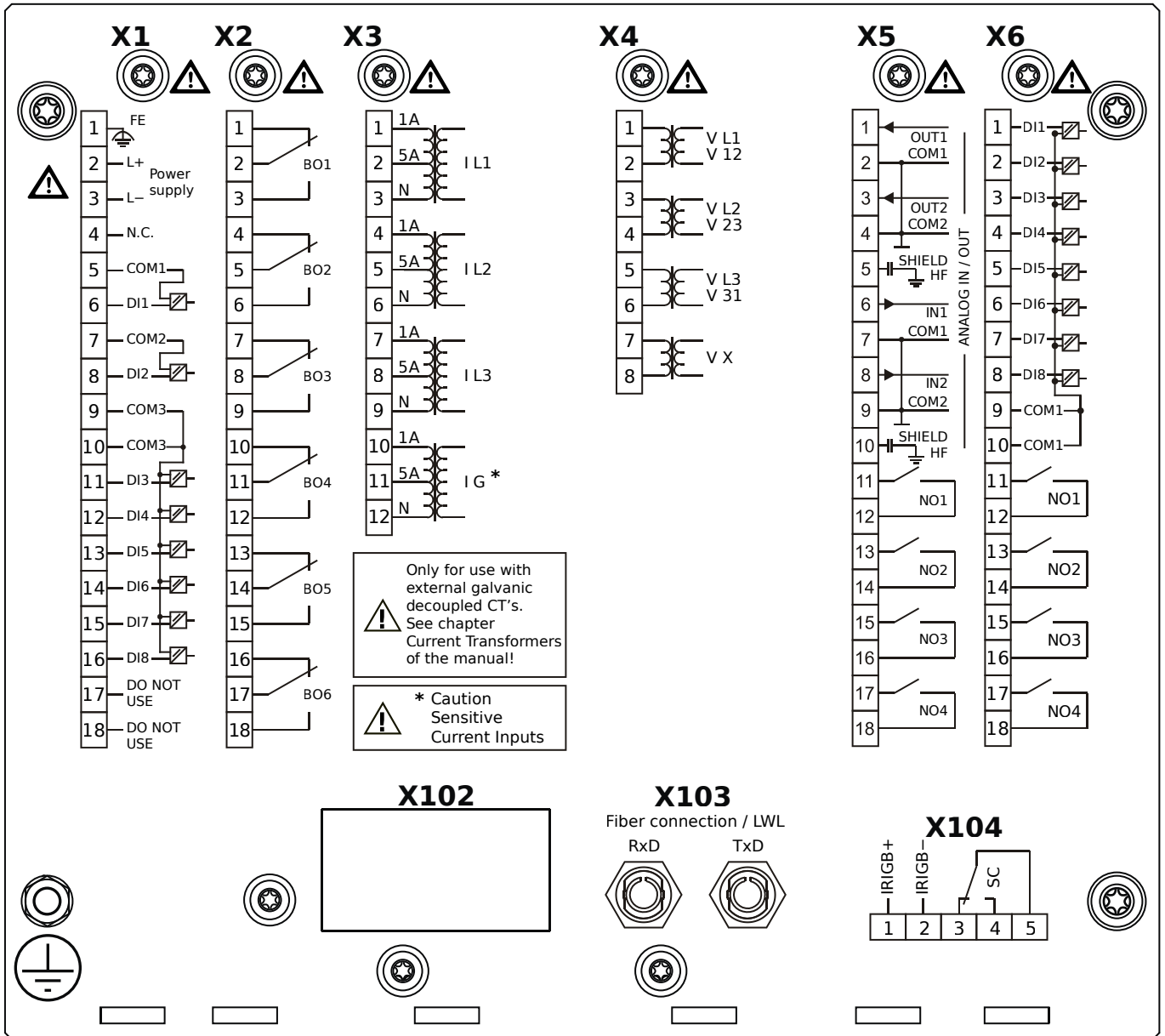

Housing B2, small display, door mounting

+ Conformal Coating (for installations in harsh environment)

- X1** – DI8-X1: Wide-range power supply unit, incl. 2 non-grouped digital inputs and 6 grouped digital inputs
- X2** – OR6: Assembly Group with 6 Output Relays (Changeover / Form C)
- X3** – TIs: Standard phase current measuring card and sensitive ground current measuring
- X4** – TU: Card with 4 voltage transformer measuring inputs (0 ... 800 VAC, under UL: 0 ... 600 VAC)
- X5** – AnIO2-OR4: Assembly Group with 2 Analog Inputs, 2 Analog Outputs and 4 Output Relays
- X6** – DI8-OR4: Assembly Group with 8 Digital Inputs and 4 Output Relays (NO / Form A)
- X103** – Profibus-DP, Fiber optics interface, ST Connector
- X104** – IRIG-B00X, incl. System Contact (Supervision Contact)

MRA4-2F1AEA

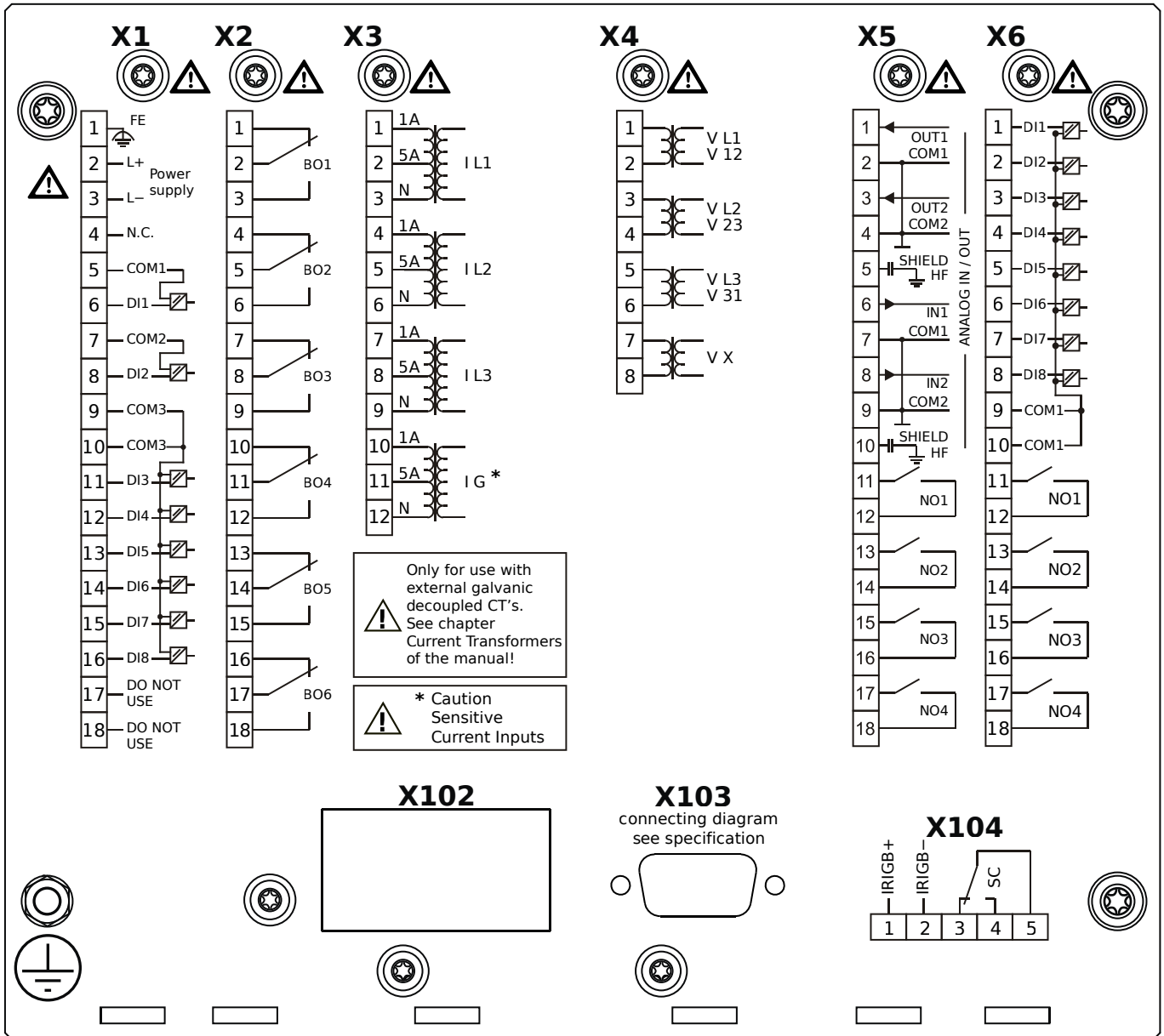

Housing B2, small display, door mounting

- X1** – DI8-X1: Wide-range power supply unit, incl. 2 non-grouped digital inputs and 6 grouped digital inputs
- X2** – OR6: Assembly Group with 6 Output Relays (Changeover / Form C)
- X3** – TIs: Standard phase current measuring card and sensitive ground current measuring
- X4** – TU: Card with 4 voltage transformer measuring inputs (0 ... 800 VAC, under UL: 0 ... 600 VAC)
- X5** – AnIO2-OR4: Assembly Group with 2 Analog Inputs, 2 Analog Outputs and 4 Output Relays
- X6** – DI8-OR4: Assembly Group with 8 Digital Inputs and 4 Output Relays (NO / Form A)
- X103** – Profibus-DP, RS485, D-SUB
- X104** – IRIG-B00X, incl. System Contact (Supervision Contact)

MRA4-2F1AEB

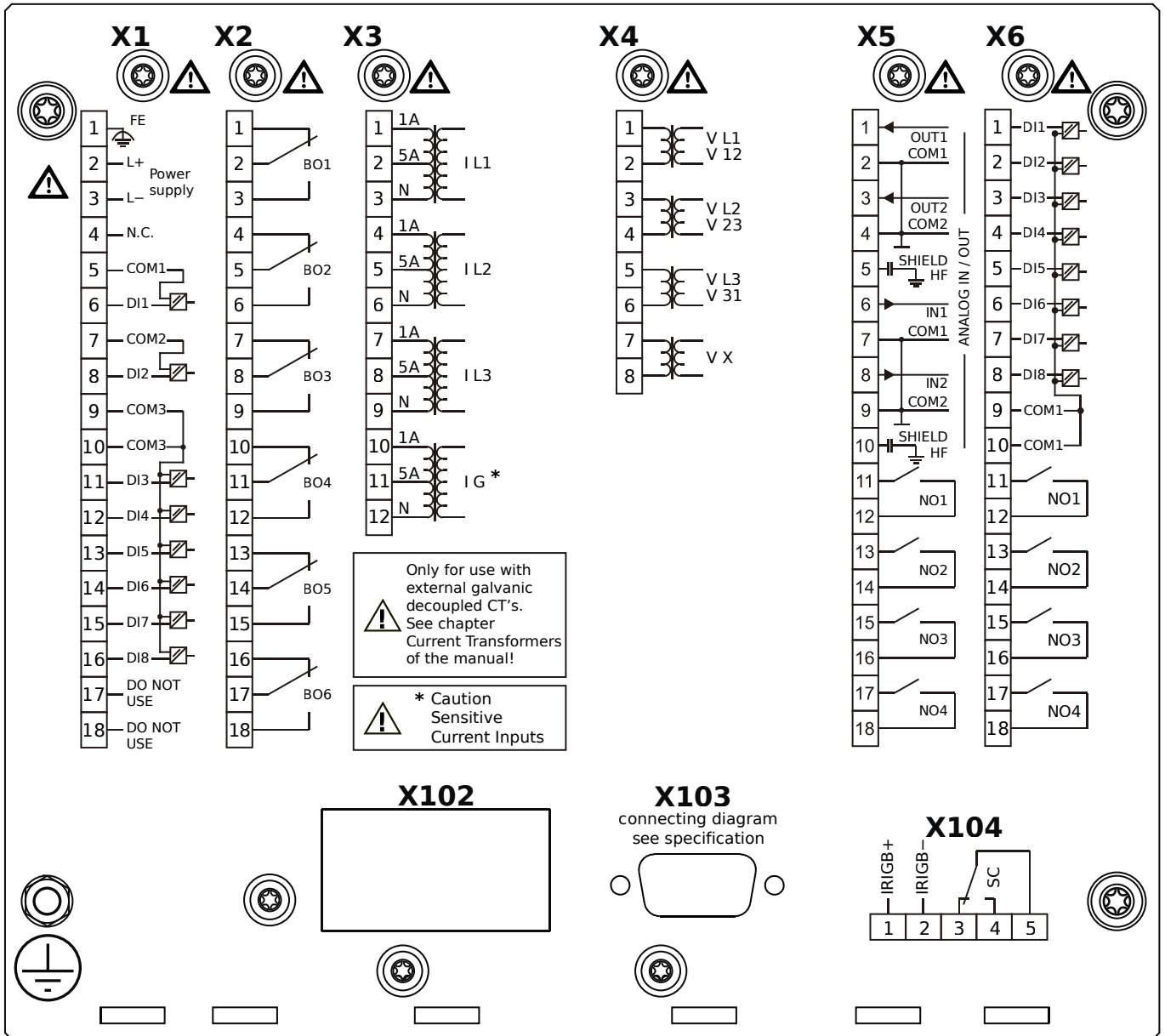

Housing B2, small display, door mounting

+ Conformal Coating (for installations in harsh environment)

- X1** – DI8-X1: Wide-range power supply unit, incl. 2 non-grouped digital inputs and 6 grouped digital inputs
- X2** – OR6: Assembly Group with 6 Output Relays (Changeover / Form C)
- X3** – TIs: Standard phase current measuring card and sensitive ground current measuring
- X4** – TU: Card with 4 voltage transformer measuring inputs (0 ... 800 VAC, under UL: 0 ... 600 VAC)
- X5** – AnIO2-OR4: Assembly Group with 2 Analog Inputs, 2 Analog Outputs and 4 Output Relays
- X6** – DI8-OR4: Assembly Group with 8 Digital Inputs and 4 Output Relays (NO / Form A)
- X103** – Profibus-DP, RS485, D-SUB
- X104** – IRIG-B00X, incl. System Contact (Supervision Contact)

MRA4-2F1AFA

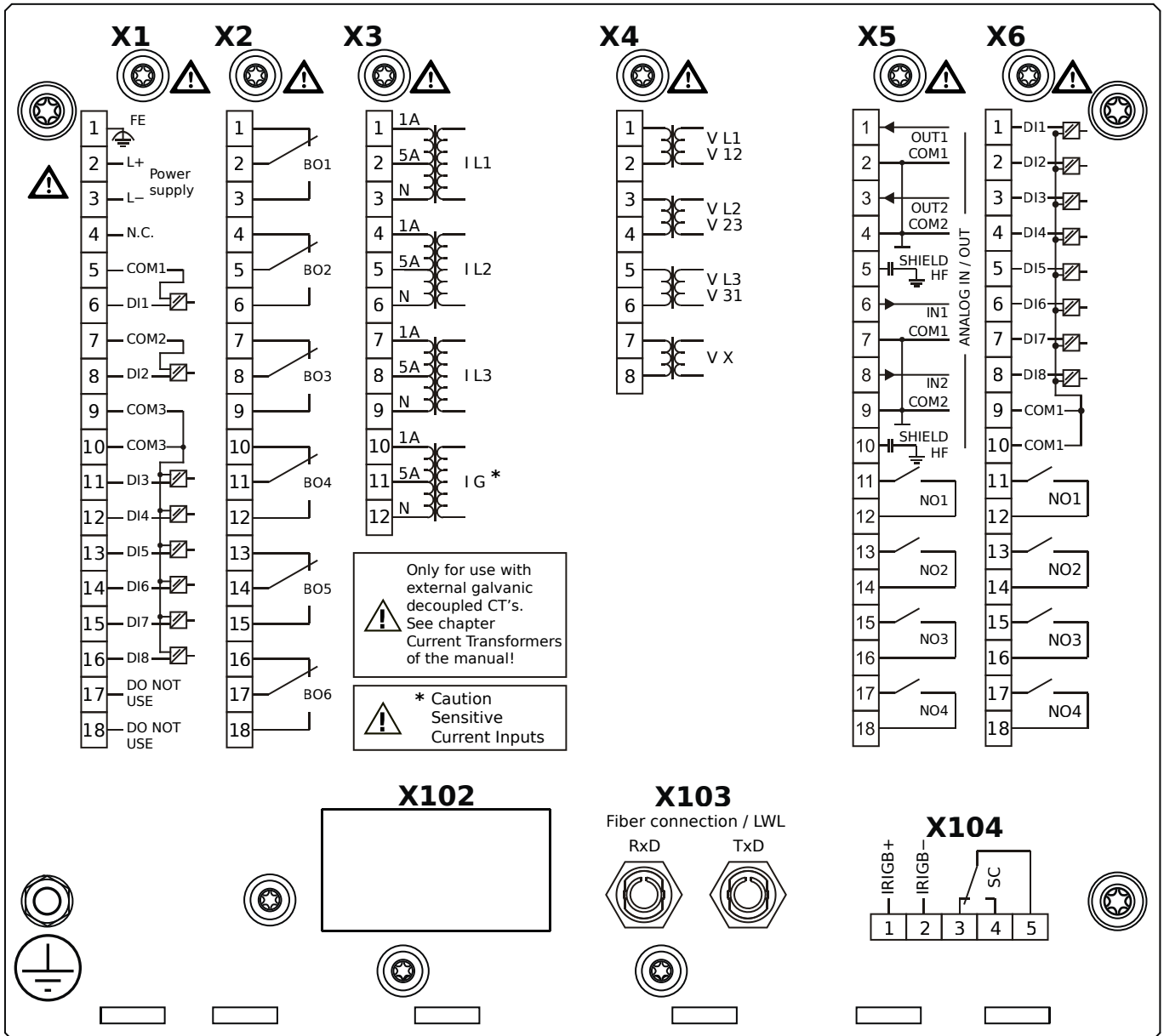

Housing B2, small display, door mounting

- X1** – DI8-X1: Wide-range power supply unit, incl. 2 non-grouped digital inputs and 6 grouped digital inputs
- X2** – OR6: Assembly Group with 6 Output Relays (Changeover / Form C)
- X3** – TIs: Standard phase current measuring card and sensitive ground current measuring
- X4** – TU: Card with 4 voltage transformer measuring inputs (0 ... 800 VAC, under UL: 0 ... 600 VAC)
- X5** – AnIO2-OR4: Assembly Group with 2 Analog Inputs, 2 Analog Outputs and 4 Output Relays
- X6** – DI8-OR4: Assembly Group with 8 Digital Inputs and 4 Output Relays (NO / Form A)
- X103** – Modbus RTU / IEC 60870-5-103 / DNP3.0 RTU, Fiber optics interface, ST Connector
- X104** – IRIG-B00X, incl. System Contact (Supervision Contact)

MRA4-2F1AFB

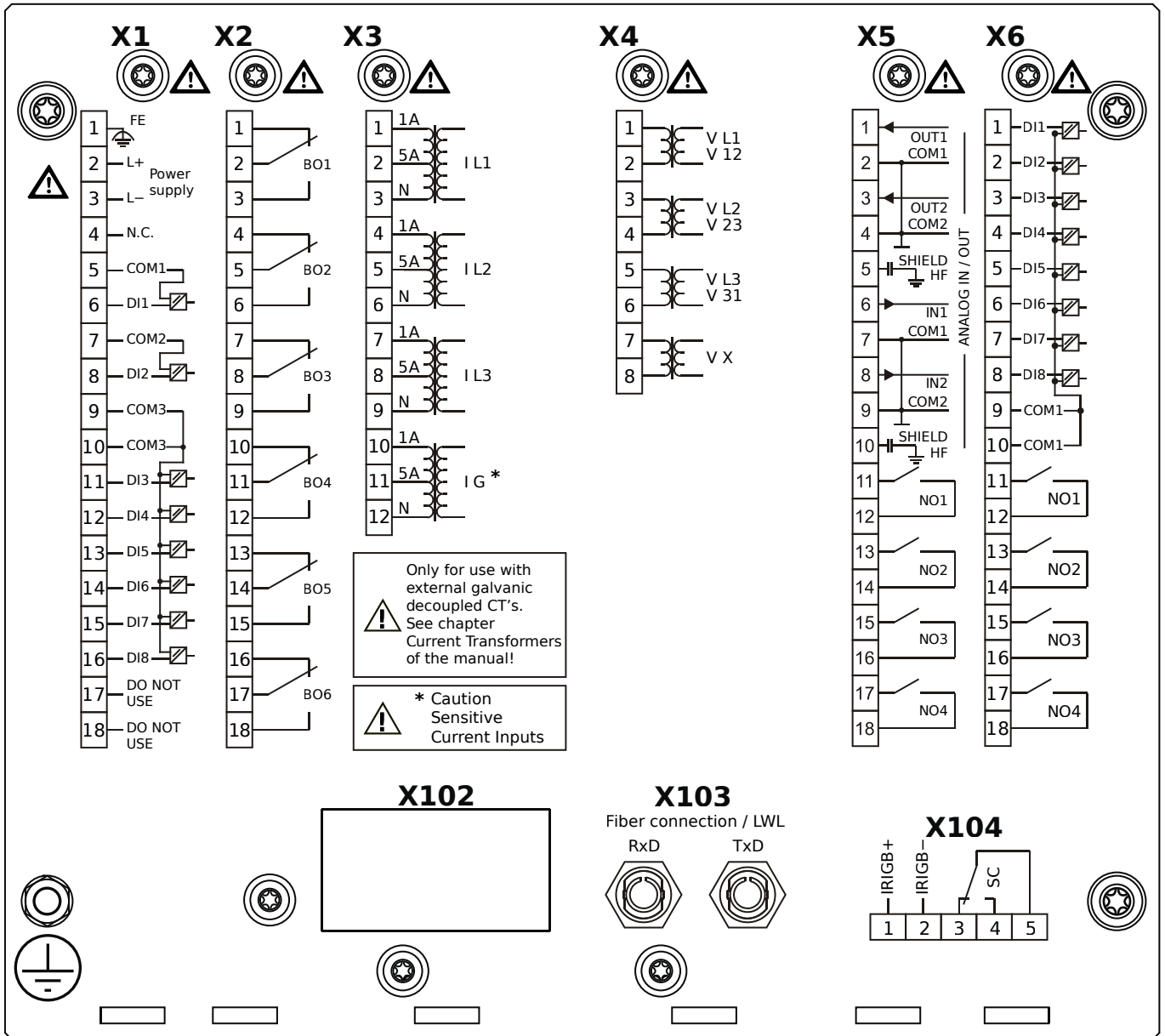

Housing B2, small display, door mounting

+ Conformal Coating (for installations in harsh environment)

- X1** – DI8-X1: Wide-range power supply unit, incl. 2 non-grouped digital inputs and 6 grouped digital inputs
- X2** – OR6: Assembly Group with 6 Output Relays (Changeover / Form C)
- X3** – TIs: Standard phase current measuring card and sensitive ground current measuring
- X4** – TU: Card with 4 voltage transformer measuring inputs (0 ... 800 VAC, under UL: 0 ... 600 VAC)
- X5** – AnIO2-OR4: Assembly Group with 2 Analog Inputs, 2 Analog Outputs and 4 Output Relays
- X6** – DI8-OR4: Assembly Group with 8 Digital Inputs and 4 Output Relays (NO / Form A)
- X103** – Modbus RTU / IEC 60870-5-103 / DNP3.0 RTU, Fiber optics interface, ST Connector
- X104** – IRIG-B00X, incl. System Contact (Supervision Contact)

MRA4-2F1AGA

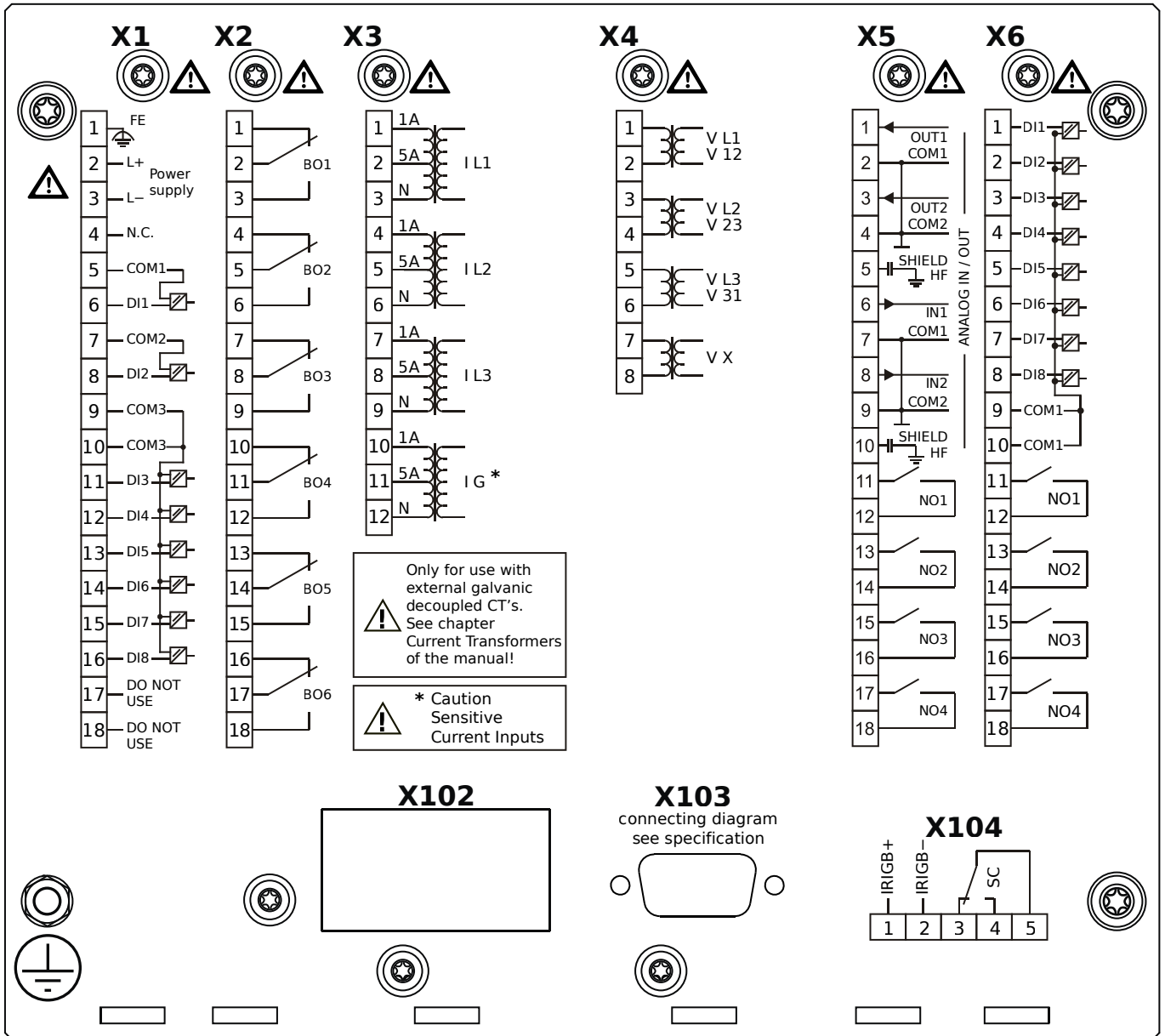

Housing B2, small display, door mounting

- X1** – DI8-X1: Wide-range power supply unit, incl. 2 non-grouped digital inputs and 6 grouped digital inputs
- X2** – OR6: Assembly Group with 6 Output Relays (Changeover / Form C)
- X3** – TIs: Standard phase current measuring card and sensitive ground current measuring
- X4** – TU: Card with 4 voltage transformer measuring inputs (0 ... 800 VAC, under UL: 0 ... 600 VAC)
- X5** – AnIO2-OR4: Assembly Group with 2 Analog Inputs, 2 Analog Outputs and 4 Output Relays
- X6** – DI8-OR4: Assembly Group with 8 Digital Inputs and 4 Output Relays (NO / Form A)
- X103** – Modbus RTU / IEC 60870-5-103 / DNP3.0 RTU, RS485, D-SUB
- X104** – IRIG-B00X, incl. System Contact (Supervision Contact)

MRA4-2F1AGB

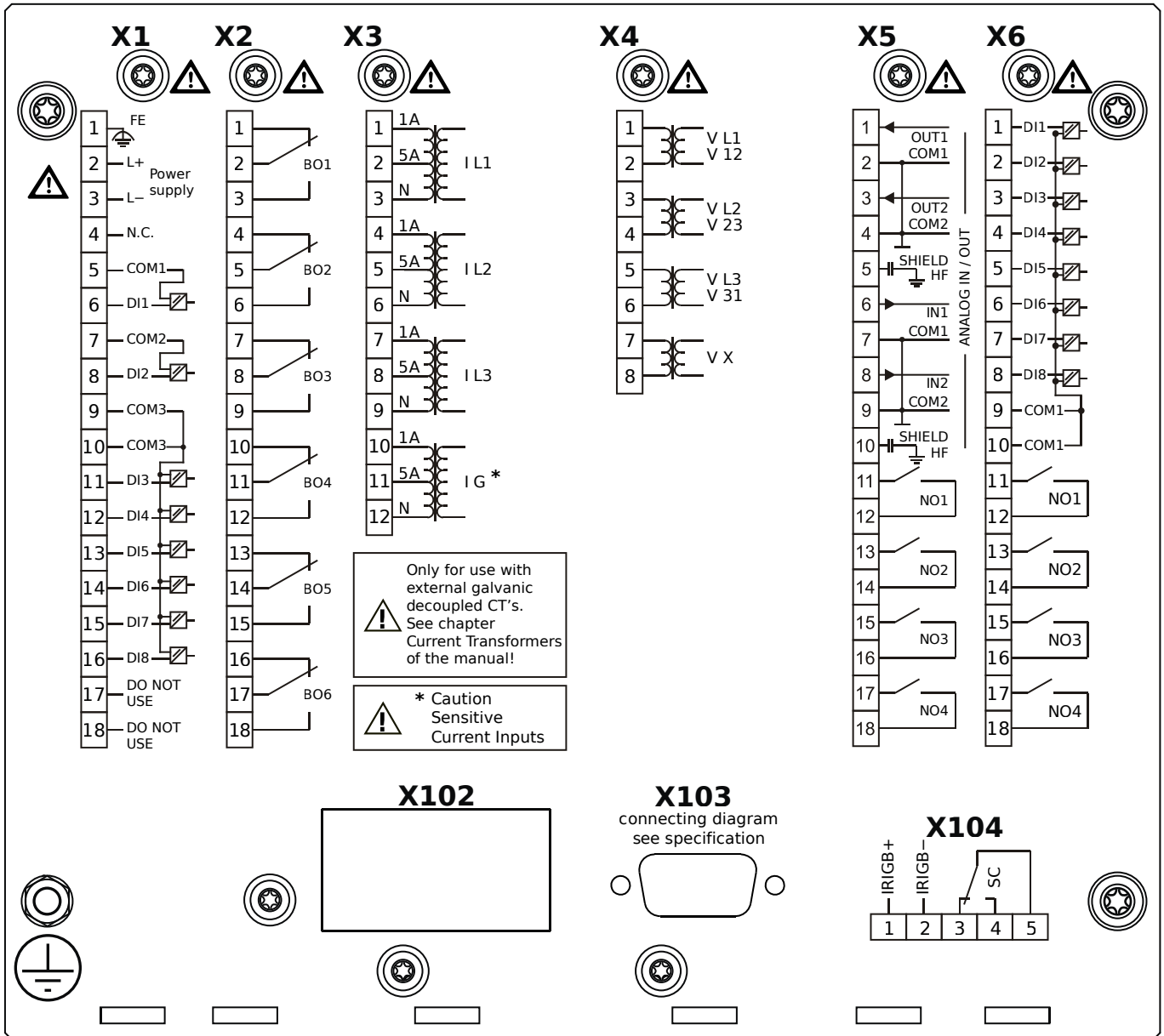

Housing B2, small display, door mounting

+ Conformal Coating (for installations in harsh environment)

- X1** – DI8-X1: Wide-range power supply unit, incl. 2 non-grouped digital inputs and 6 grouped digital inputs
- X2** – OR6: Assembly Group with 6 Output Relays (Changeover / Form C)
- X3** – TIs: Standard phase current measuring card and sensitive ground current measuring
- X4** – TU: Card with 4 voltage transformer measuring inputs (0 ... 800 VAC, under UL: 0 ... 600 VAC)
- X5** – AnIO2-OR4: Assembly Group with 2 Analog Inputs, 2 Analog Outputs and 4 Output Relays
- X6** – DI8-OR4: Assembly Group with 8 Digital Inputs and 4 Output Relays (NO / Form A)
- X103** – Modbus RTU / IEC 60870-5-103 / DNP3.0 RTU, RS485, D-SUB
- X104** – IRIG-B00X, incl. System Contact (Supervision Contact)

MRA4-2F1AHA

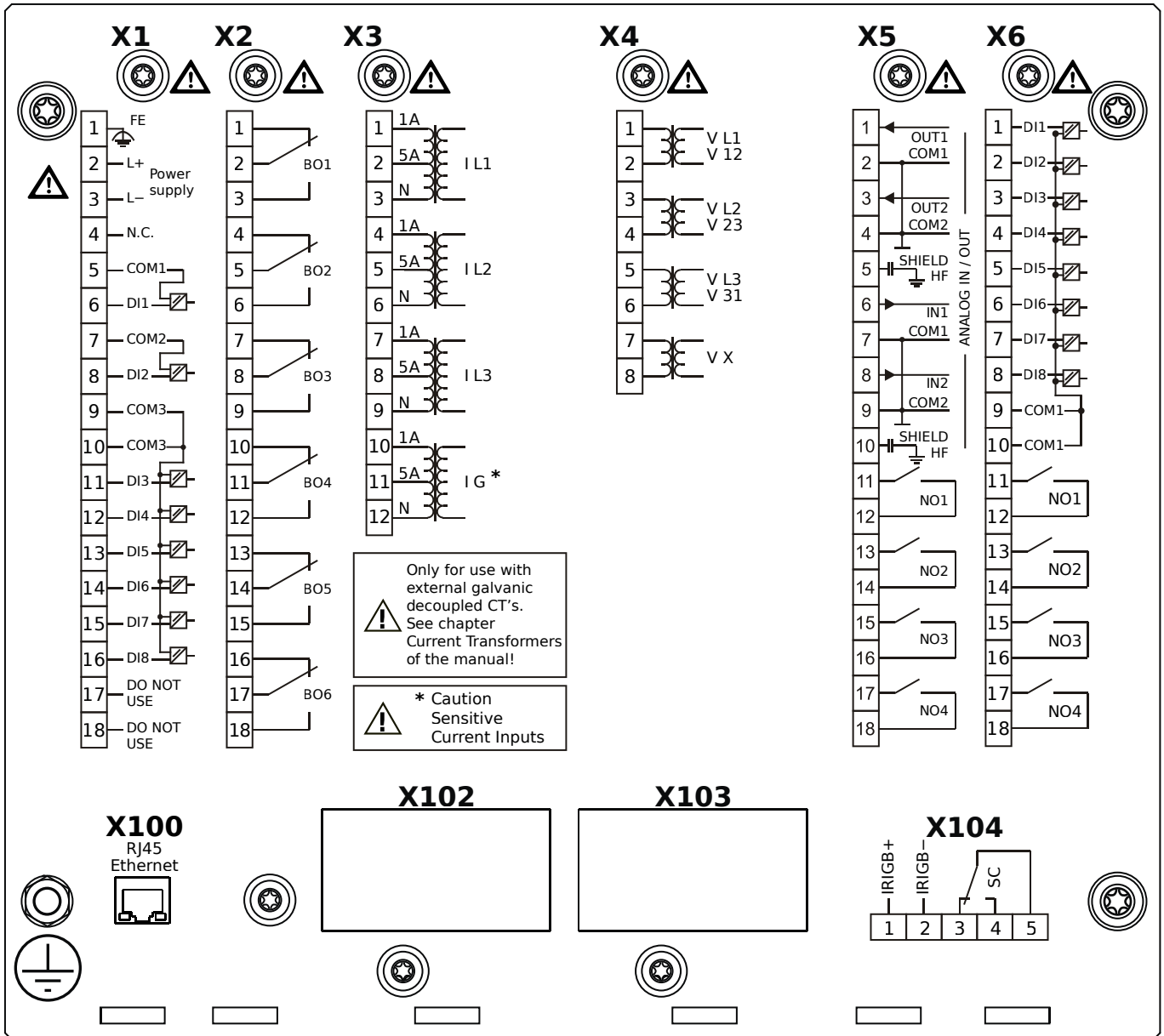

Housing B2, small display, door mounting

- X1** – DI8-X1: Wide-range power supply unit, incl. 2 non-grouped digital inputs and 6 grouped digital inputs
- X2** – OR6: Assembly Group with 6 Output Relays (Changeover / Form C)
- X3** – TIs: Standard phase current measuring card and sensitive ground current measuring
- X4** – TU: Card with 4 voltage transformer measuring inputs (0 ... 800 VAC, under UL: 0 ... 600 VAC)
- X5** – AnIO2-OR4: Assembly Group with 2 Analog Inputs, 2 Analog Outputs and 4 Output Relays
- X6** – DI8-OR4: Assembly Group with 8 Digital Inputs and 4 Output Relays (NO / Form A)
- X100** – IEC 61850 / Modbus TCP / DNP3.0 TCP/UDP, Ethernet interface, 100 Mbit/s, RJ45 (BASE100-FX)
- X104** – IRIG-B00X, incl. System Contact (Supervision Contact)

MRA4-2F1AHB

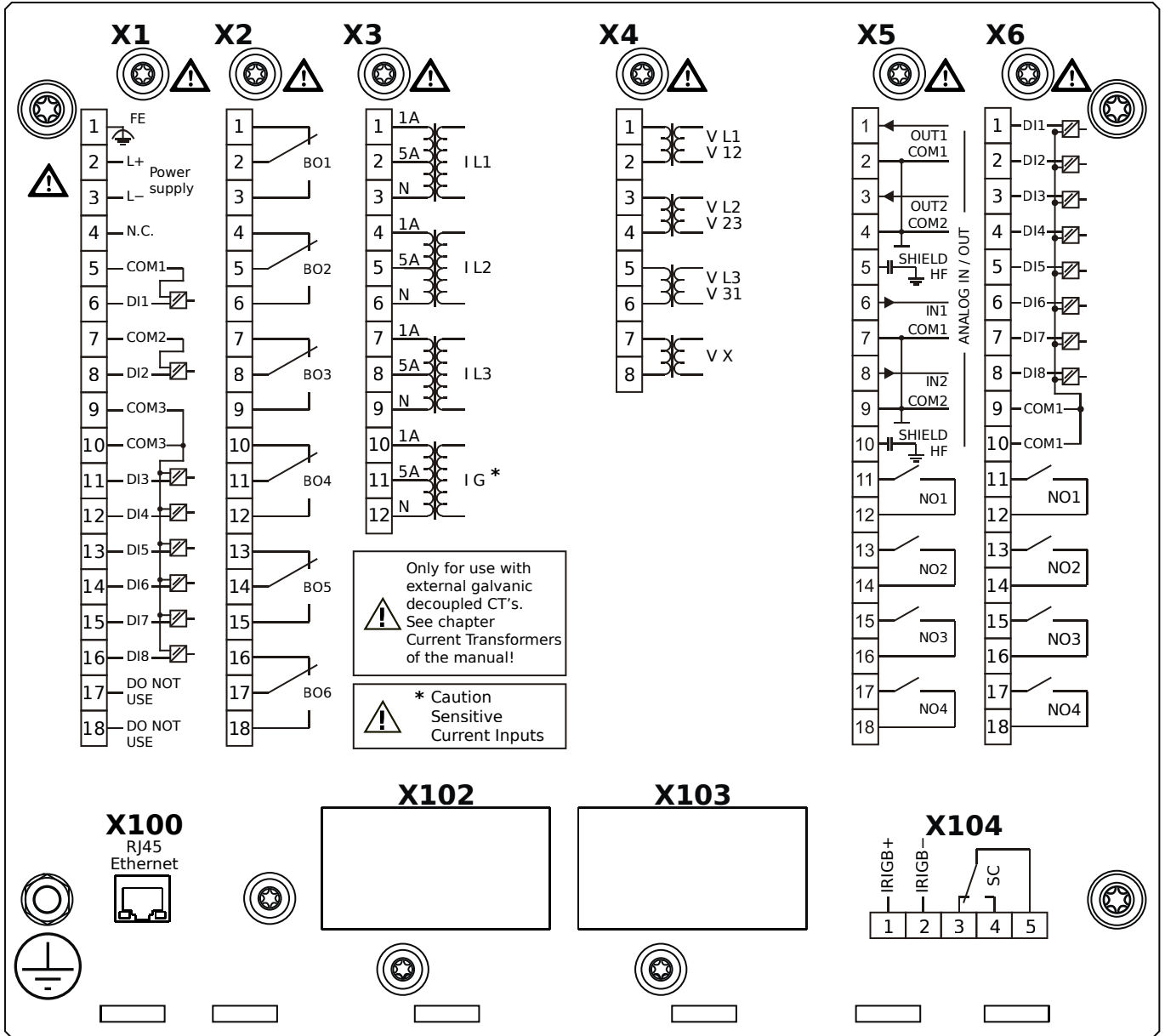

Housing B2, small display, door mounting

+ Conformal Coating (for installations in harsh environment)

- X1** – DI8-X1: Wide-range power supply unit, incl. 2 non-grouped digital inputs and 6 grouped digital inputs
- X2** – OR6: Assembly Group with 6 Output Relays (Changeover / Form C)
- X3** – TIs: Standard phase current measuring card and sensitive ground current measuring
- X4** – TU: Card with 4 voltage transformer measuring inputs (0 ... 800 VAC, under UL: 0 ... 600 VAC)
- X5** – AnIO2-OR4: Assembly Group with 2 Analog Inputs, 2 Analog Outputs and 4 Output Relays
- X6** – DI8-OR4: Assembly Group with 8 Digital Inputs and 4 Output Relays (NO / Form A)
- X100** – IEC 61850 / Modbus TCP / DNP3.0 TCP/UDP, Ethernet interface, 100 Mbit/s, RJ45 (BASE100-FX)
- X104** – IRIG-B00X, incl. System Contact (Supervision Contact)

MRA4-2F1AIA

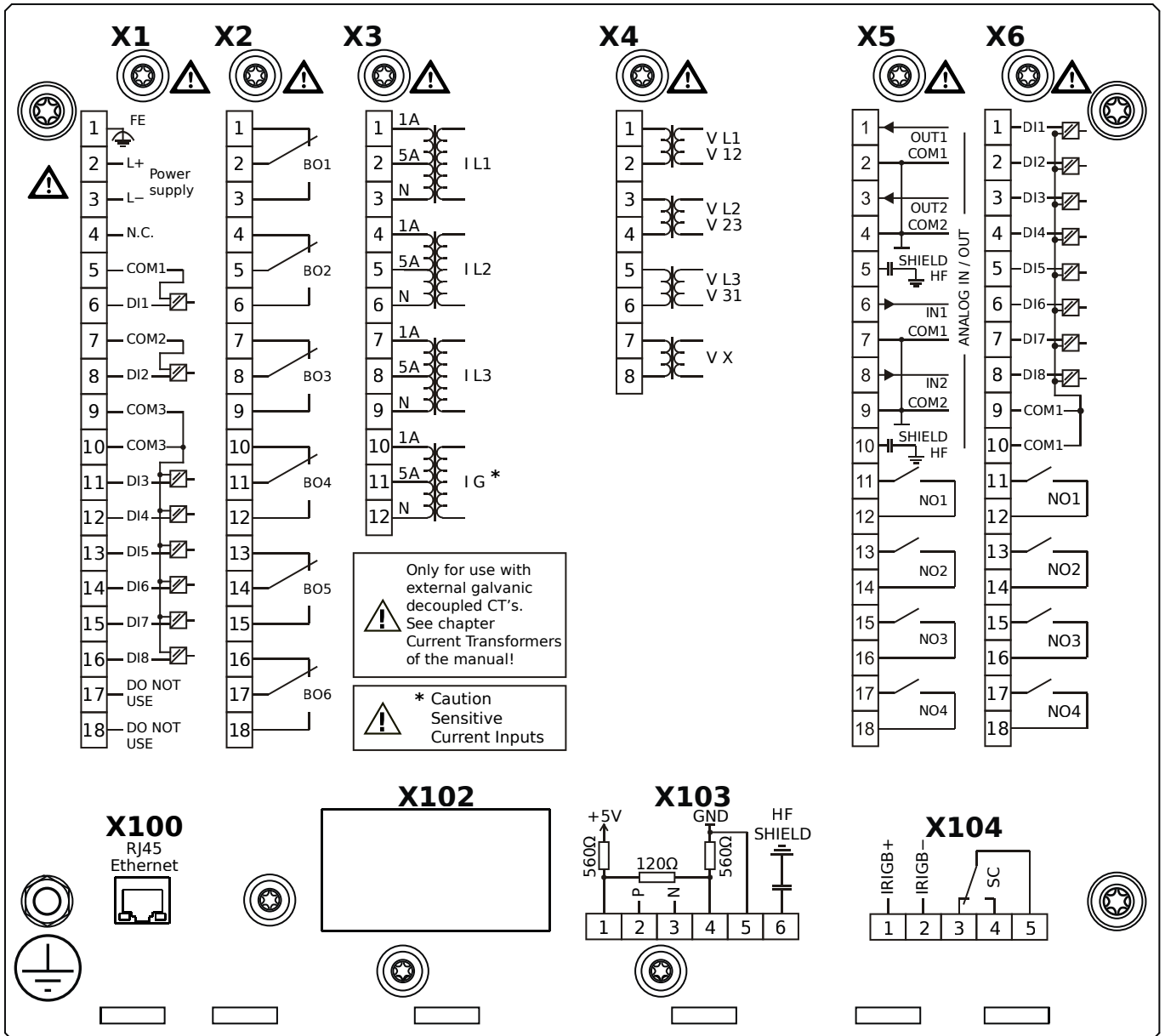

Housing B2, small display, door mounting

- X1** – DI8-X1: Wide-range power supply unit, incl. 2 non-grouped digital inputs and 6 grouped digital inputs
- X2** – OR6: Assembly Group with 6 Output Relays (Changeover / Form C)
- X3** – TIs: Standard phase current measuring card and sensitive ground current measuring
- X4** – TU: Card with 4 voltage transformer measuring inputs (0 ... 800 VAC, under UL: 0 ... 600 VAC)
- X5** – AnIO2-OR4: Assembly Group with 2 Analog Inputs, 2 Analog Outputs and 4 Output Relays
- X6** – DI8-OR4: Assembly Group with 8 Digital Inputs and 4 Output Relays (NO / Form A)
- X100** – Modbus TCP / DNP3.0 TCP/UDP, Ethernet interface, 100 Mbit/s, RJ45 (BASE100-FX)
- X103** – IEC 60870-5-103 / Modbus RTU / DNP3.0 RTU, RS485, Terminals
- X104** – IRIG-B00X, incl. System Contact (Supervision Contact)

MRA4-2F1AIB

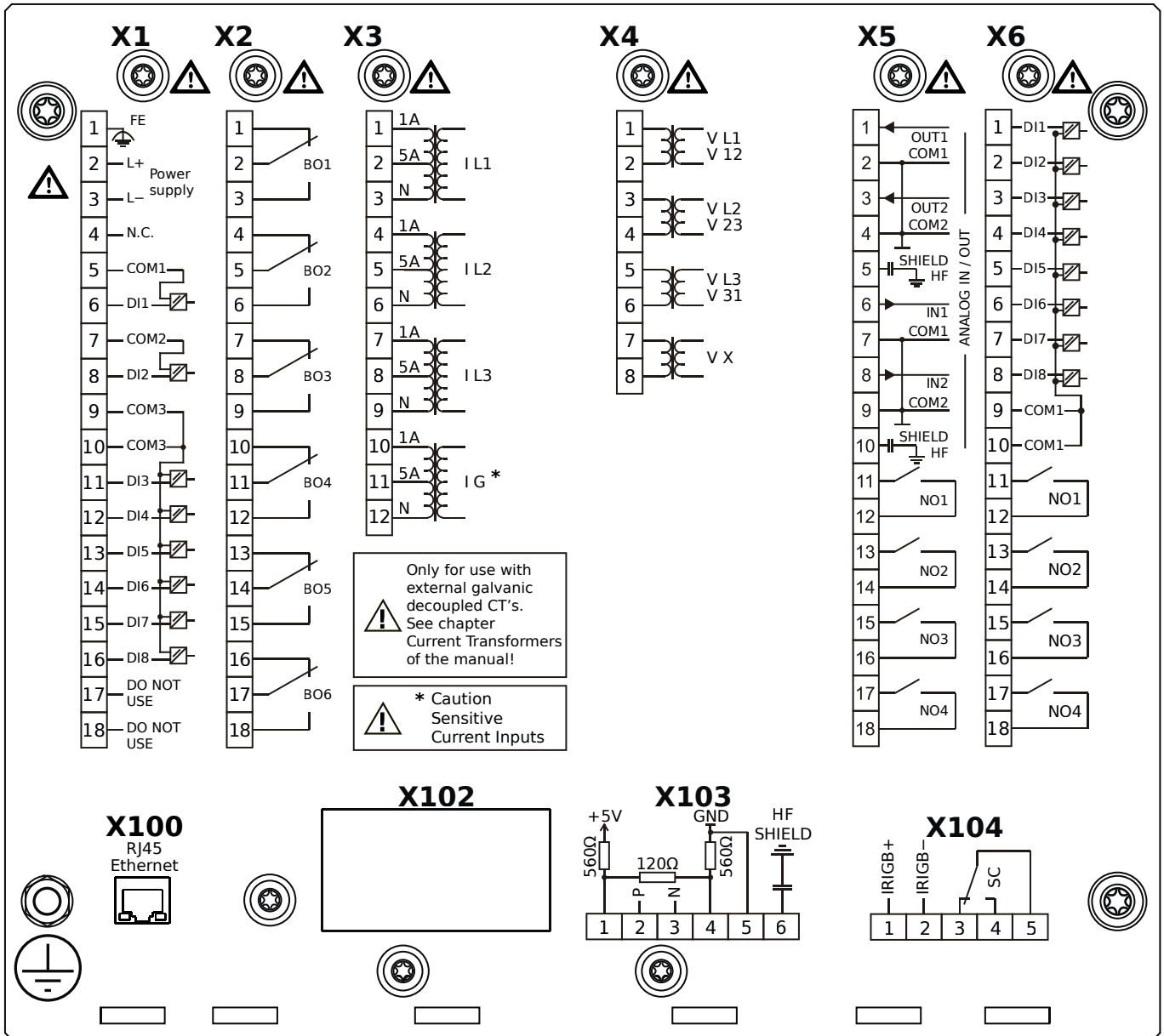

Housing B2, small display, door mounting

+ Conformal Coating (for installations in harsh environment)

- X1** – DI8-X1: Wide-range power supply unit, incl. 2 non-grouped digital inputs and 6 grouped digital inputs
- X2** – OR6: Assembly Group with 6 Output Relays (Changeover / Form C)
- X3** – TIs: Standard phase current measuring card and sensitive ground current measuring
- X4** – TU: Card with 4 voltage transformer measuring inputs (0 ... 800 VAC, under UL: 0 ... 600 VAC)
- X5** – AnIO2-OR4: Assembly Group with 2 Analog Inputs, 2 Analog Outputs and 4 Output Relays
- X6** – DI8-OR4: Assembly Group with 8 Digital Inputs and 4 Output Relays (NO / Form A)
- X100** – Modbus TCP / DNP3.0 TCP/UDP, Ethernet interface, 100 Mbit/s, RJ45 (BASE100-FX)
- X103** – IEC 60870-5-103 / Modbus RTU / DNP3.0 RTU, RS485, Terminals
- X104** – IRIG-B00X, incl. System Contact (Supervision Contact)

MRA4-2F1AKA

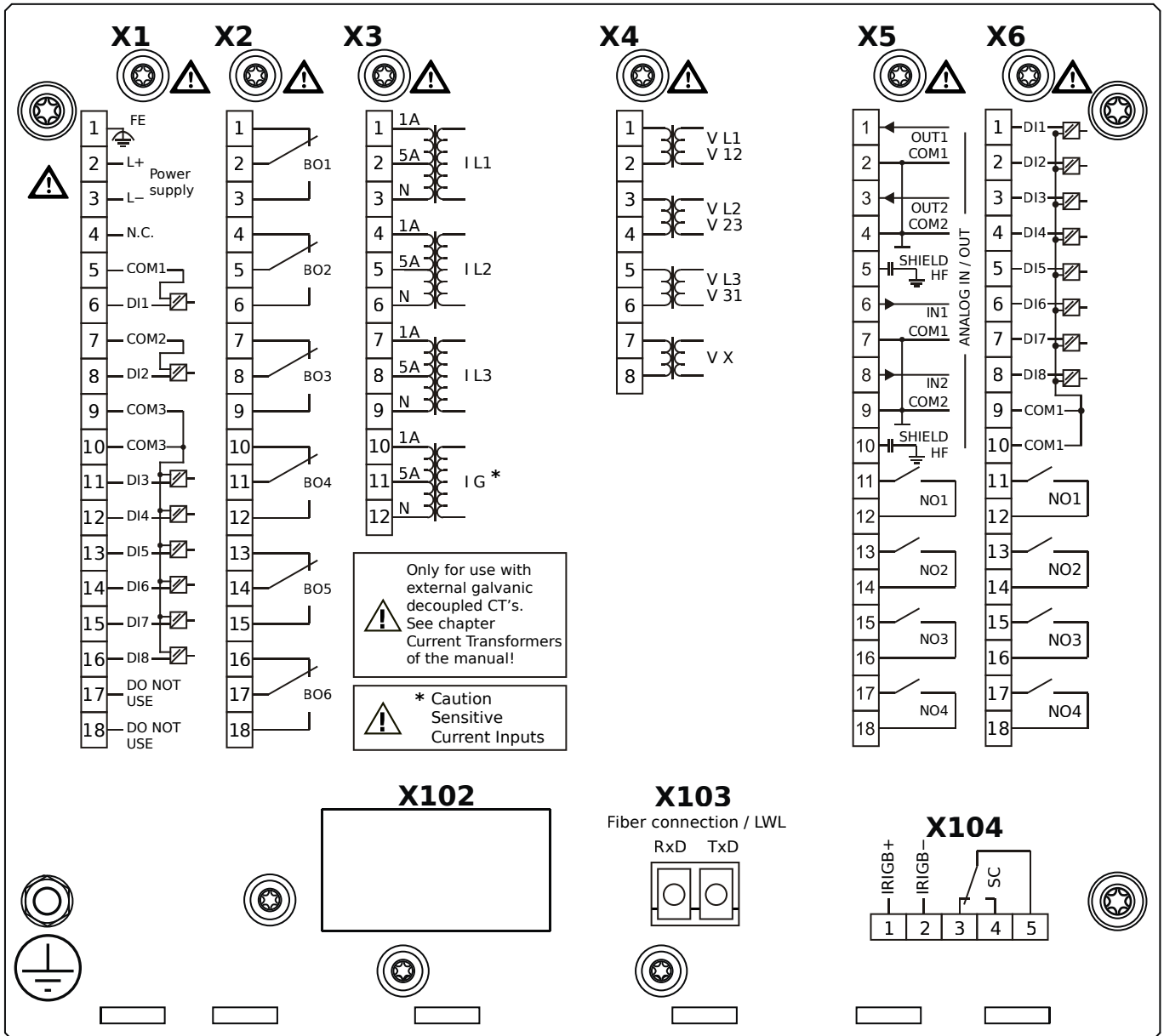

Housing B2, small display, door mounting

- X1** – DI8-X1: Wide-range power supply unit, incl. 2 non-grouped digital inputs and 6 grouped digital inputs
- X2** – OR6: Assembly Group with 6 Output Relays (Changeover / Form C)
- X3** – TIs: Standard phase current measuring card and sensitive ground current measuring
- X4** – TU: Card with 4 voltage transformer measuring inputs (0 ... 800 VAC, under UL: 0 ... 600 VAC)
- X5** – AnIO2-OR4: Assembly Group with 2 Analog Inputs, 2 Analog Outputs and 4 Output Relays
- X6** – DI8-OR4: Assembly Group with 8 Digital Inputs and 4 Output Relays (NO / Form A)
- X103** – IEC 61850 / Modbus TCP / DNP3.0 TCP/UDP, Fiber optics interface, LC Connector
- X104** – IRIG-B00X, incl. System Contact (Supervision Contact)

MRA4-2F1AKB

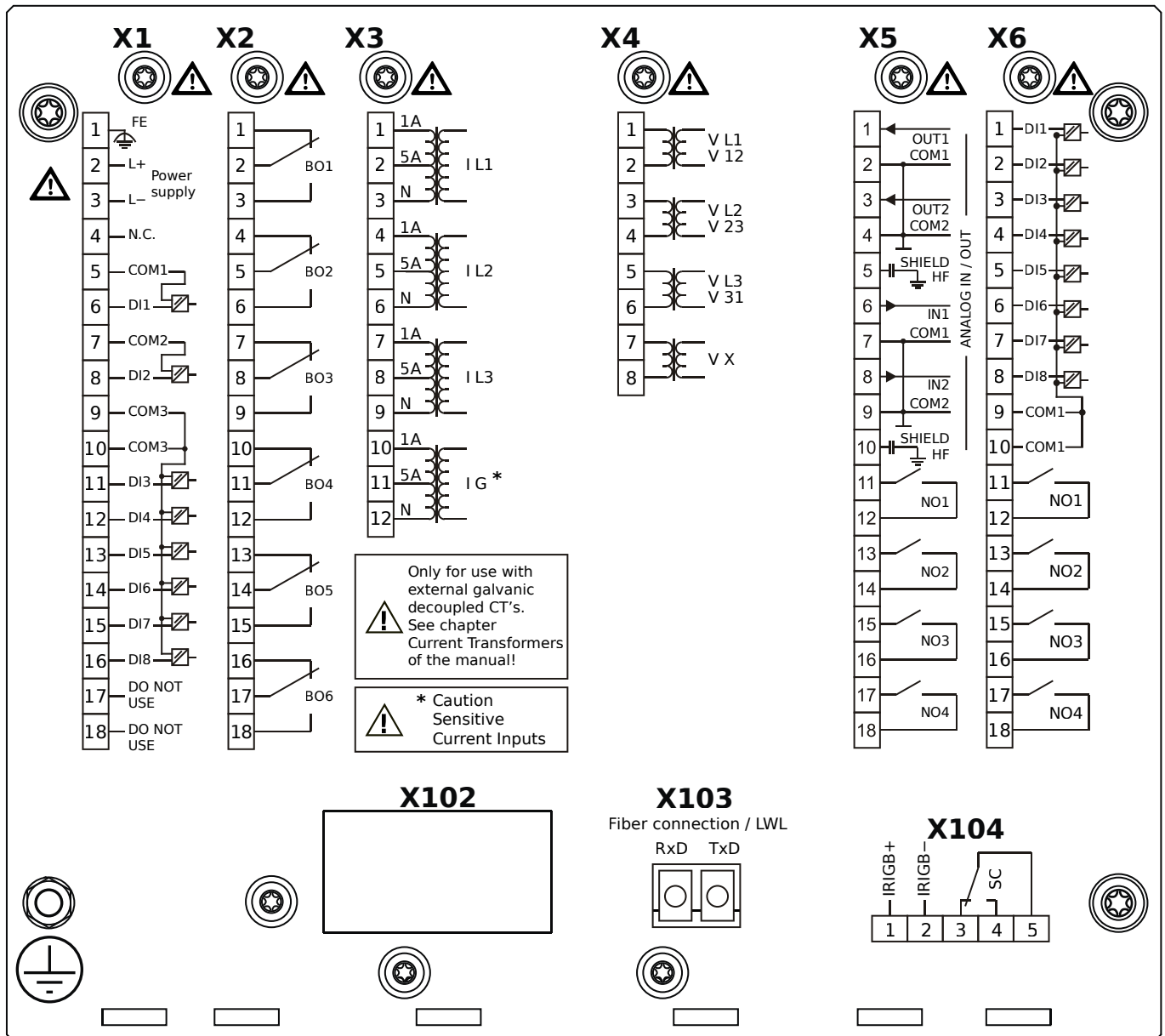

Housing B2, small display, door mounting

+ Conformal Coating (for installations in harsh environment)

- X1** – DI8-X1: Wide-range power supply unit, incl. 2 non-grouped digital inputs and 6 grouped digital inputs
- X2** – OR6: Assembly Group with 6 Output Relays (Changeover / Form C)
- X3** – TIs: Standard phase current measuring card and sensitive ground current measuring
- X4** – TU: Card with 4 voltage transformer measuring inputs (0 ... 800 VAC, under UL: 0 ... 600 VAC)
- X5** – AnIO2-OR4: Assembly Group with 2 Analog Inputs, 2 Analog Outputs and 4 Output Relays
- X6** – DI8-OR4: Assembly Group with 8 Digital Inputs and 4 Output Relays (NO / Form A)
- X103** – IEC 61850 / Modbus TCP / DNP3.0 TCP/UDP, Fiber optics interface, LC Connector
- X104** – IRIG-B00X, incl. System Contact (Supervision Contact)

MRA4-2F1ALA

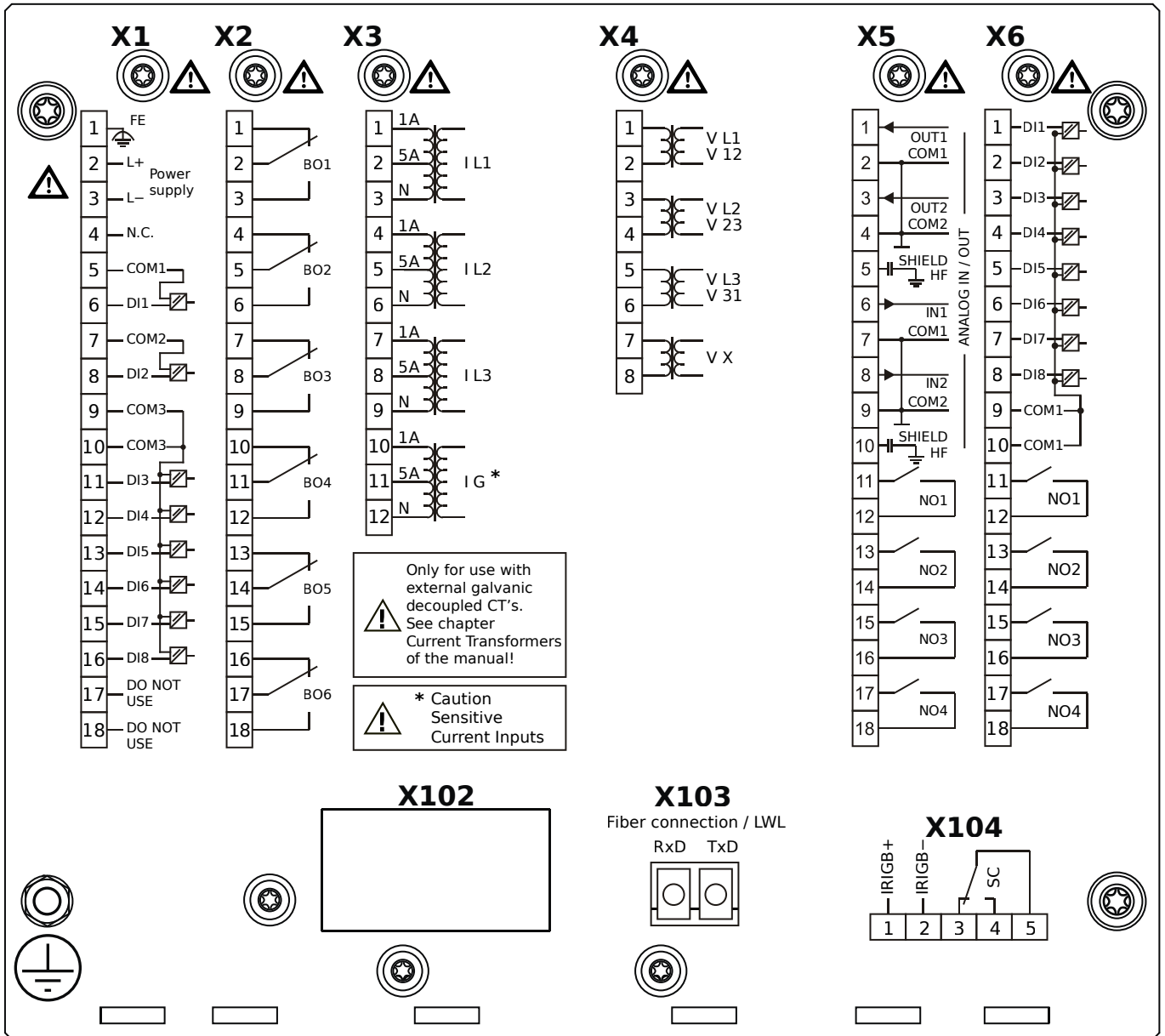

Housing B2, small display, door mounting

- X1** – DI8-X1: Wide-range power supply unit, incl. 2 non-grouped digital inputs and 6 grouped digital inputs
- X2** – OR6: Assembly Group with 6 Output Relays (Changeover / Form C)
- X3** – TIs: Standard phase current measuring card and sensitive ground current measuring
- X4** – TU: Card with 4 voltage transformer measuring inputs (0 ... 800 VAC, under UL: 0 ... 600 VAC)
- X5** – AnIO2-OR4: Assembly Group with 2 Analog Inputs, 2 Analog Outputs and 4 Output Relays
- X6** – DI8-OR4: Assembly Group with 8 Digital Inputs and 4 Output Relays (NO / Form A)
- X103** – Modbus TCP / DNP3.0 TCP/UDP, Fiber optics interface, LC Connector
- X104** – IRIG-B00X, incl. System Contact (Supervision Contact)

MRA4-2F1ALB

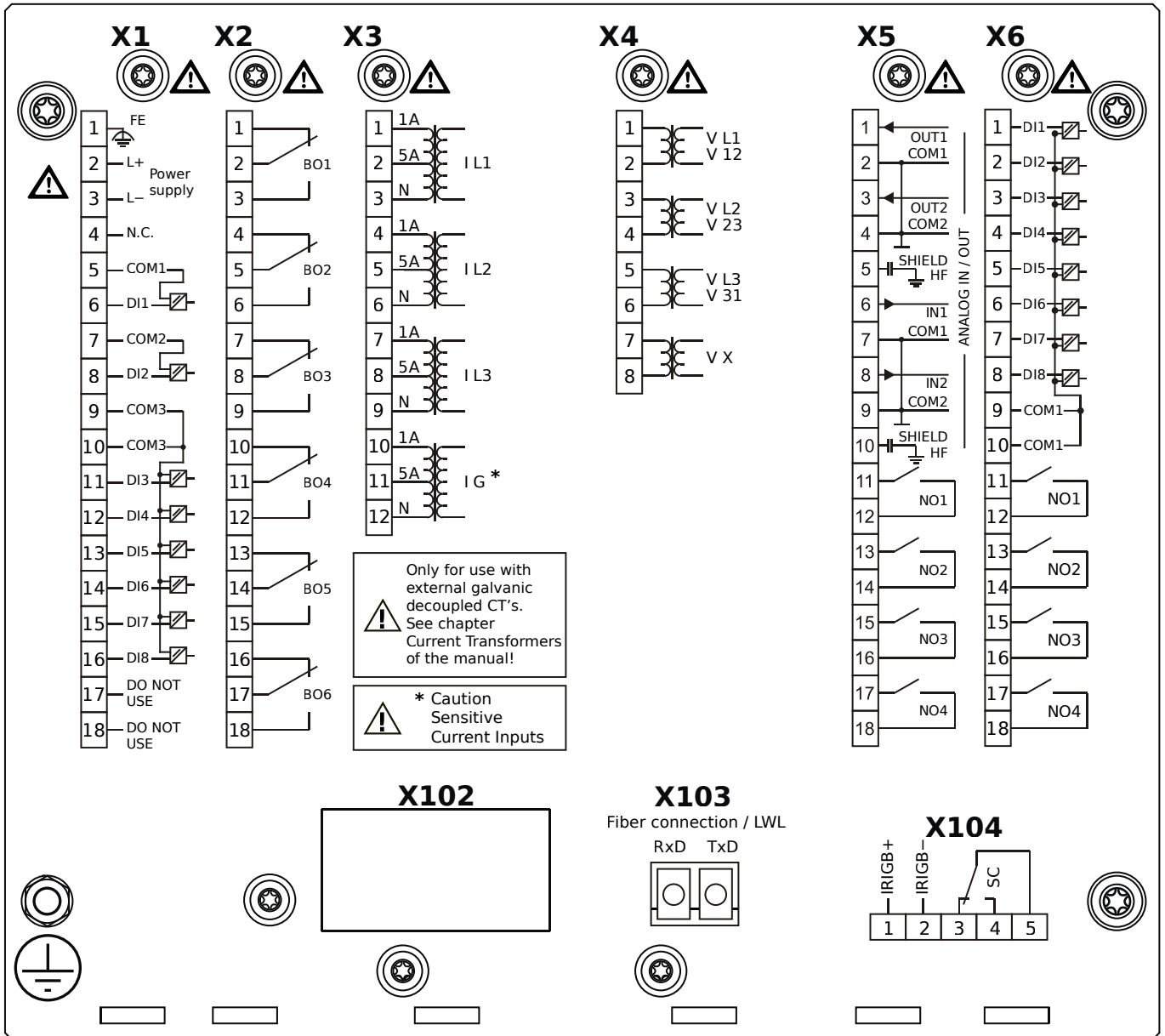

Housing B2, small display, door mounting

+ Conformal Coating (for installations in harsh environment)

- X1** – DI8-X1: Wide-range power supply unit, incl. 2 non-grouped digital inputs and 6 grouped digital inputs
- X2** – OR6: Assembly Group with 6 Output Relays (Changeover / Form C)
- X3** – TIs: Standard phase current measuring card and sensitive ground current measuring
- X4** – TU: Card with 4 voltage transformer measuring inputs (0 ... 800 VAC, under UL: 0 ... 600 VAC)
- X5** – AnIO2-OR4: Assembly Group with 2 Analog Inputs, 2 Analog Outputs and 4 Output Relays
- X6** – DI8-OR4: Assembly Group with 8 Digital Inputs and 4 Output Relays (NO / Form A)
- X103** – Modbus TCP / DNP3.0 TCP/UDP, Fiber optics interface, LC Connector
- X104** – IRIG-B00X, incl. System Contact (Supervision Contact)

MRA4-2F1ATA

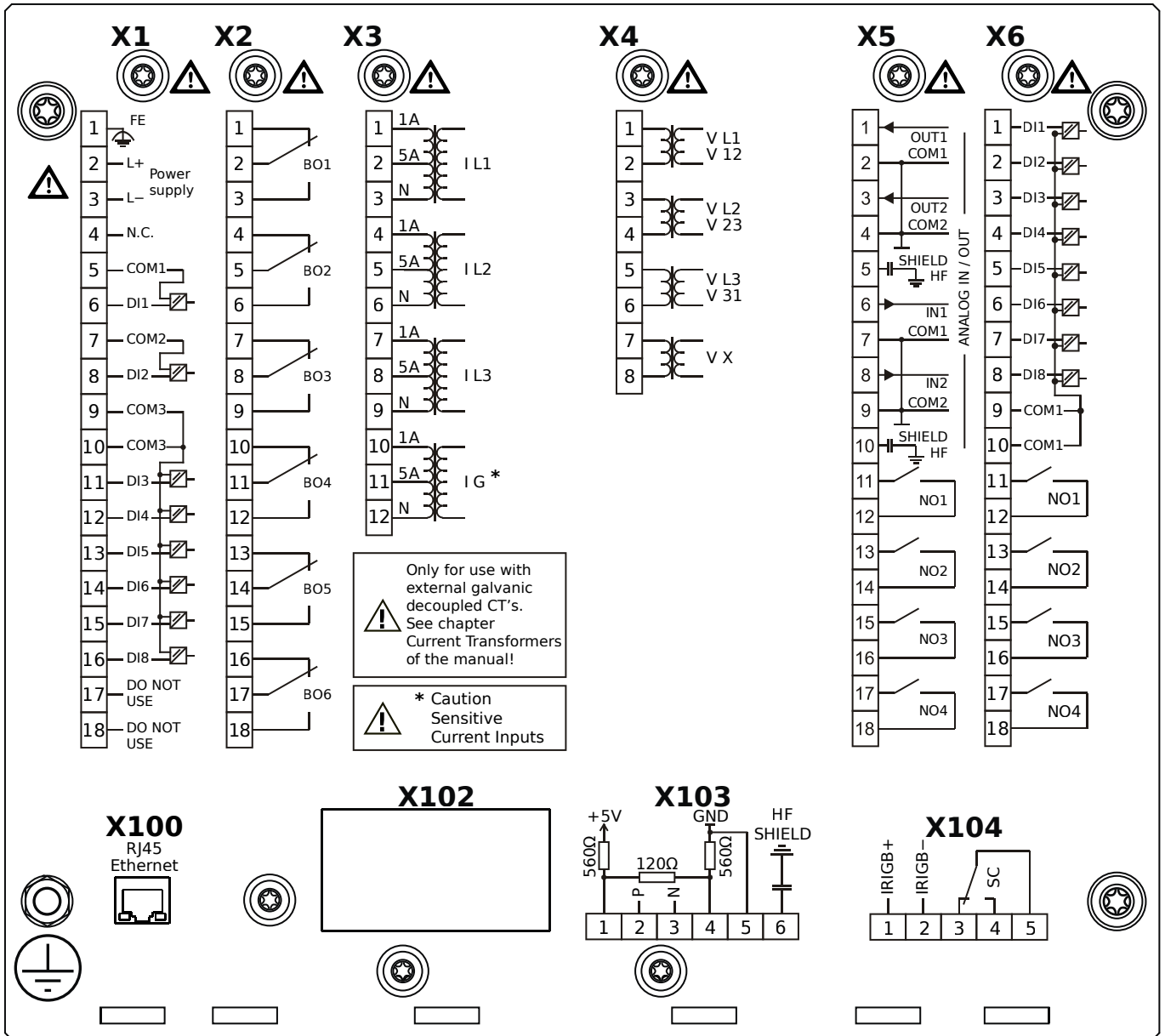

Housing B2, small display, door mounting

- X1** – DI8-X1: Wide-range power supply unit, incl. 2 non-grouped digital inputs and 6 grouped digital inputs
- X2** – OR6: Assembly Group with 6 Output Relays (Changeover / Form C)
- X3** – TIs: Standard phase current measuring card and sensitive ground current measuring
- X4** – TU: Card with 4 voltage transformer measuring inputs (0 ... 800 VAC, under UL: 0 ... 600 VAC)
- X5** – AnIO2-OR4: Assembly Group with 2 Analog Inputs, 2 Analog Outputs and 4 Output Relays
- X6** – DI8-OR4: Assembly Group with 8 Digital Inputs and 4 Output Relays (NO / Form A)
- X100** – IEC 61850 / Modbus TCP / DNP3.0 TCP/UDP, Ethernet interface, 100 Mbit/s, RJ45 (BASE100-FX)
- X103** – IEC 60870-5-103 / Modbus RTU / DNP3.0 RTU, RS485, Terminals
- X104** – IRIG-B00X, incl. System Contact (Supervision Contact)

MRA4-2F1ATB

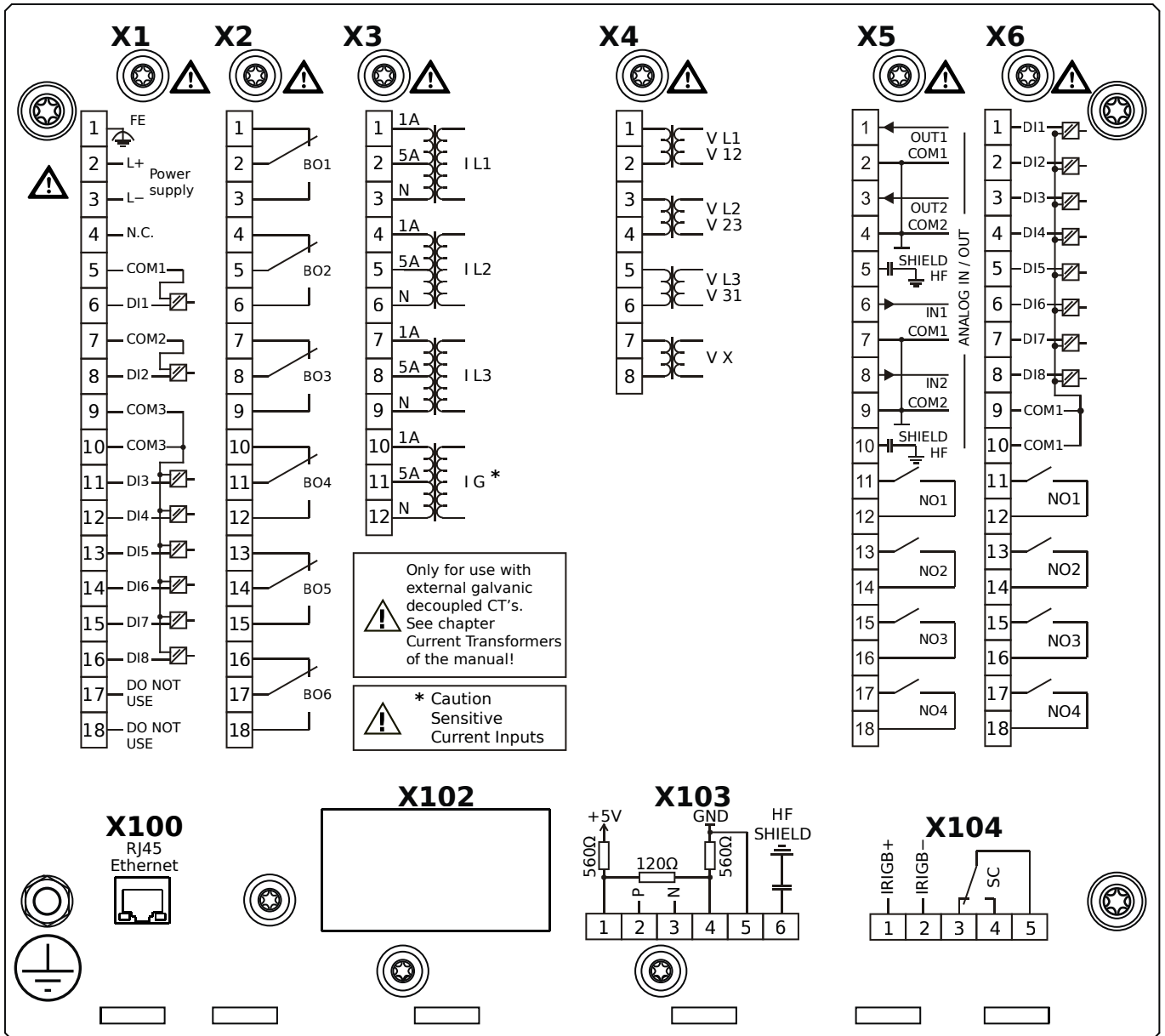

Housing B2, small display, door mounting

+ Conformal Coating (for installations in harsh environment)

- X1** – DI8-X1: Wide-range power supply unit, incl. 2 non-grouped digital inputs and 6 grouped digital inputs
- X2** – OR6: Assembly Group with 6 Output Relays (Changeover / Form C)
- X3** – TIs: Standard phase current measuring card and sensitive ground current measuring
- X4** – TU: Card with 4 voltage transformer measuring inputs (0 ... 800 VAC, under UL: 0 ... 600 VAC)
- X5** – AnIO2-OR4: Assembly Group with 2 Analog Inputs, 2 Analog Outputs and 4 Output Relays
- X6** – DI8-OR4: Assembly Group with 8 Digital Inputs and 4 Output Relays (NO / Form A)
- X100** – IEC 61850 / Modbus TCP / DNP3.0 TCP/UDP, Ethernet interface, 100 Mbit/s, RJ45 (BASE100-FX)
- X103** – IEC 60870-5-103 / Modbus RTU / DNP3.0 RTU, RS485, Terminals
- X104** – IRIG-B00X, incl. System Contact (Supervision Contact)

MRA4-2F1BAA

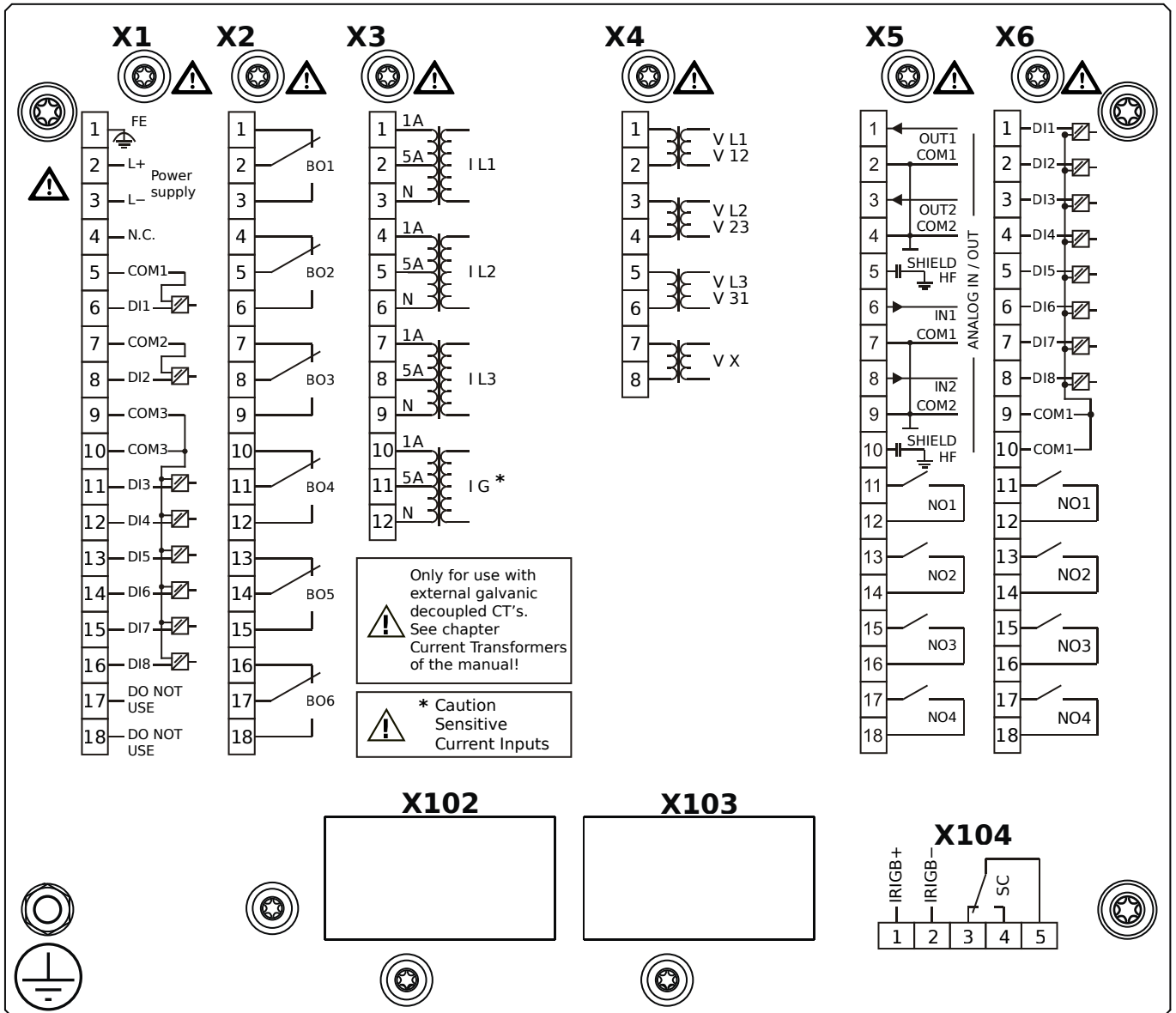

Housing B2, small display, 19" rack mounting

- X1** – DI8-X1: Wide-range power supply unit, incl. 2 non-grouped digital inputs and 6 grouped digital inputs
- X2** – OR6: Assembly Group with 6 Output Relays (Changeover / Form C)
- X3** – TIs: Standard phase current measuring card and sensitive ground current measuring
- X4** – TU: Card with 4 voltage transformer measuring inputs (0 ... 800 VAC, under UL: 0 ... 600 VAC)
- X5** – AnIO2-OR4: Assembly Group with 2 Analog Inputs, 2 Analog Outputs and 4 Output Relays
- X6** – DI8-OR4: Assembly Group with 8 Digital Inputs and 4 Output Relays (NO / Form A)
- X104** – IRIG-B00X, incl. System Contact (Supervision Contact)

MRA4-2F1BAB

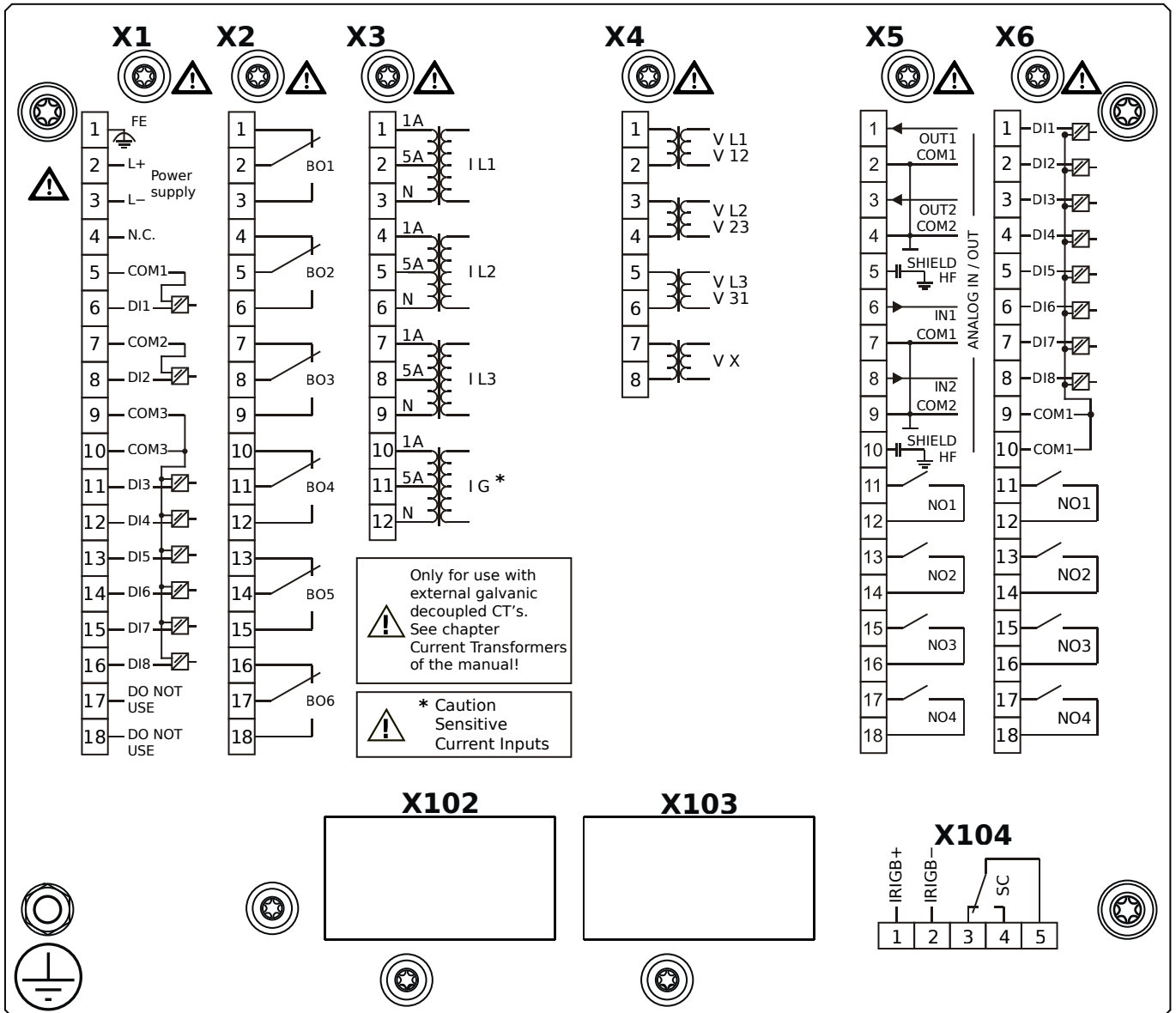

Housing B2, small display, 19" rack mounting

+ Conformal Coating (for installations in harsh environment)

- X1** – DI8-X1: Wide-range power supply unit, incl. 2 non-grouped digital inputs and 6 grouped digital inputs
- X2** – OR6: Assembly Group with 6 Output Relays (Changeover / Form C)
- X3** – TIs: Standard phase current measuring card and sensitive ground current measuring
- X4** – TU: Card with 4 voltage transformer measuring inputs (0 ... 800 VAC, under UL: 0 ... 600 VAC)
- X5** – AnIO2-OR4: Assembly Group with 2 Analog Inputs, 2 Analog Outputs and 4 Output Relays
- X6** – DI8-OR4: Assembly Group with 8 Digital Inputs and 4 Output Relays (NO / Form A)
- X104** – IRIG-B00X, incl. System Contact (Supervision Contact)

MRA4-2F1BBA

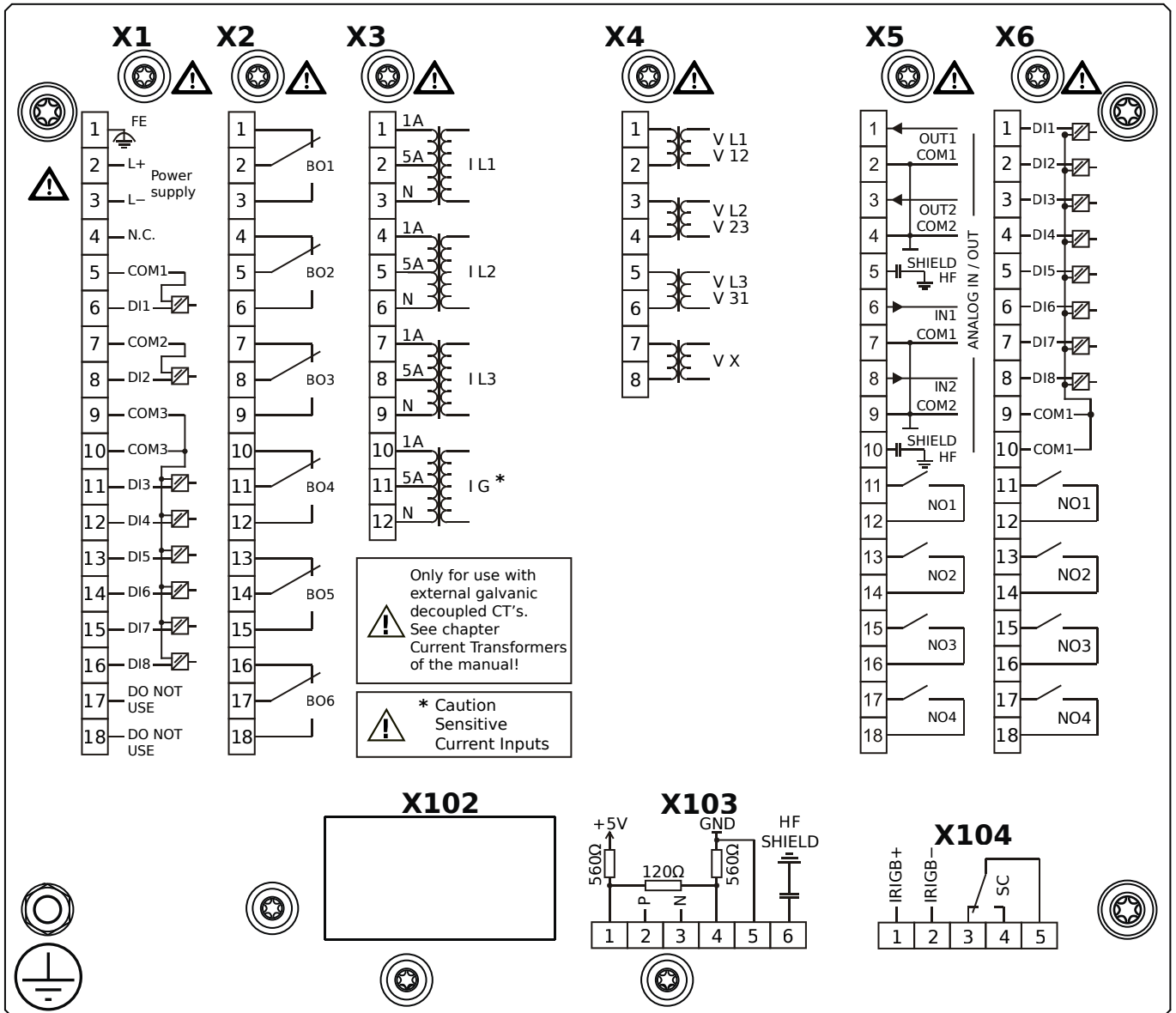

Housing B2, small display, 19" rack mounting

- X1** – DI8-X1: Wide-range power supply unit, incl. 2 non-grouped digital inputs and 6 grouped digital inputs
- X2** – OR6: Assembly Group with 6 Output Relays (Changeover / Form C)
- X3** – TIs: Standard phase current measuring card and sensitive ground current measuring
- X4** – TU: Card with 4 voltage transformer measuring inputs (0 ... 800 VAC, under UL: 0 ... 600 VAC)
- X5** – AnIO2-OR4: Assembly Group with 2 Analog Inputs, 2 Analog Outputs and 4 Output Relays
- X6** – DI8-OR4: Assembly Group with 8 Digital Inputs and 4 Output Relays (NO / Form A)
- X103** – Modbus RTU / IEC 60870-5-103 / DNP3.0 RTU, RS485, Terminals
- X104** – IRIG-B00X, incl. System Contact (Supervision Contact)

MRA4-2F1BBB

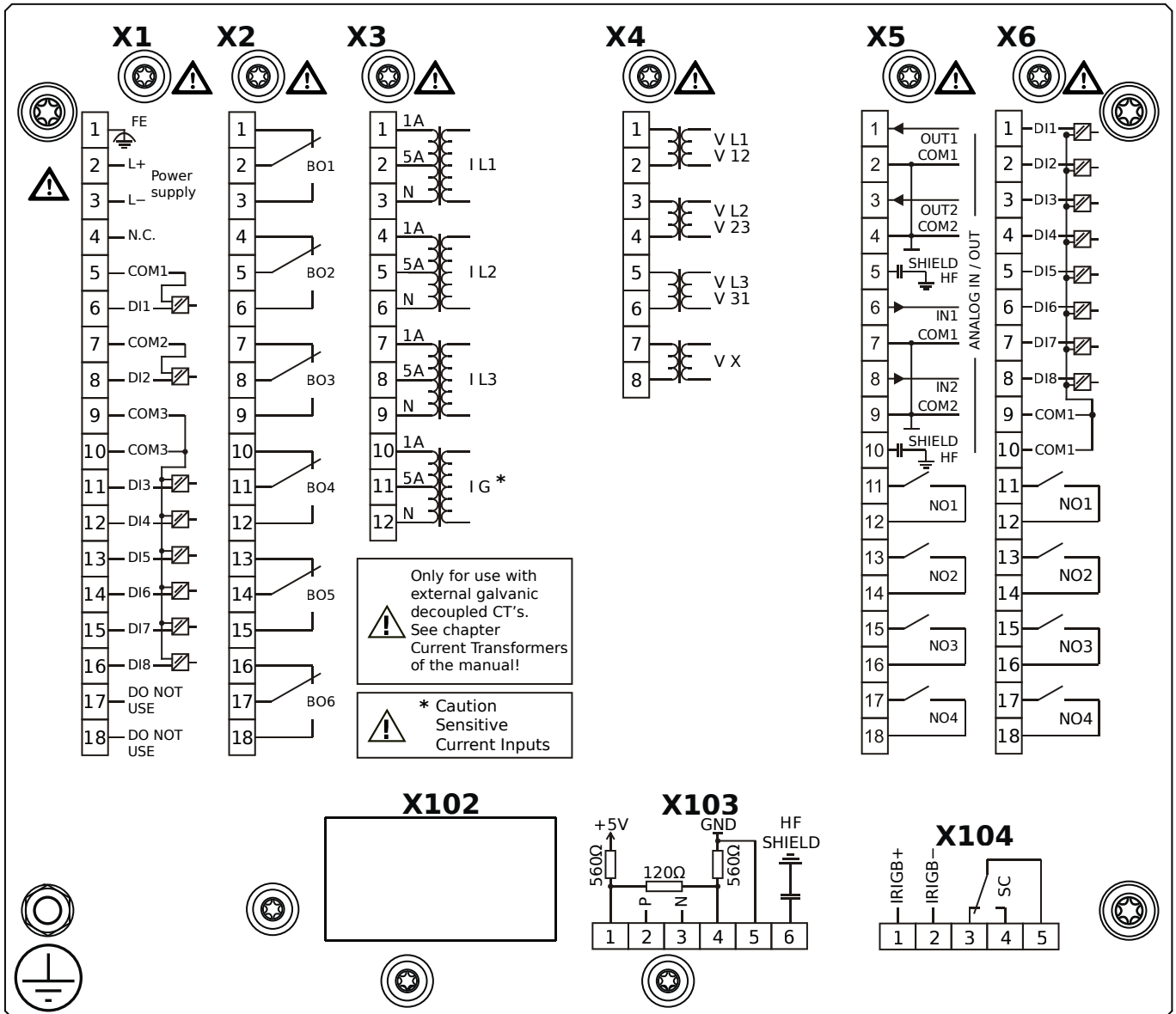

Housing B2, small display, 19" rack mounting

+ Conformal Coating (for installations in harsh environment)

- X1** – DI8-X1: Wide-range power supply unit, incl. 2 non-grouped digital inputs and 6 grouped digital inputs
- X2** – OR6: Assembly Group with 6 Output Relays (Changeover / Form C)
- X3** – TIs: Standard phase current measuring card and sensitive ground current measuring
- X4** – TU: Card with 4 voltage transformer measuring inputs (0 ... 800 VAC, under UL: 0 ... 600 VAC)
- X5** – AnIO2-OR4: Assembly Group with 2 Analog Inputs, 2 Analog Outputs and 4 Output Relays
- X6** – DI8-OR4: Assembly Group with 8 Digital Inputs and 4 Output Relays (NO / Form A)
- X103** – Modbus RTU / IEC 60870-5-103 / DNP3.0 RTU, RS485, Terminals
- X104** – IRIG-B00X, incl. System Contact (Supervision Contact)

MRA4-2F1BCA

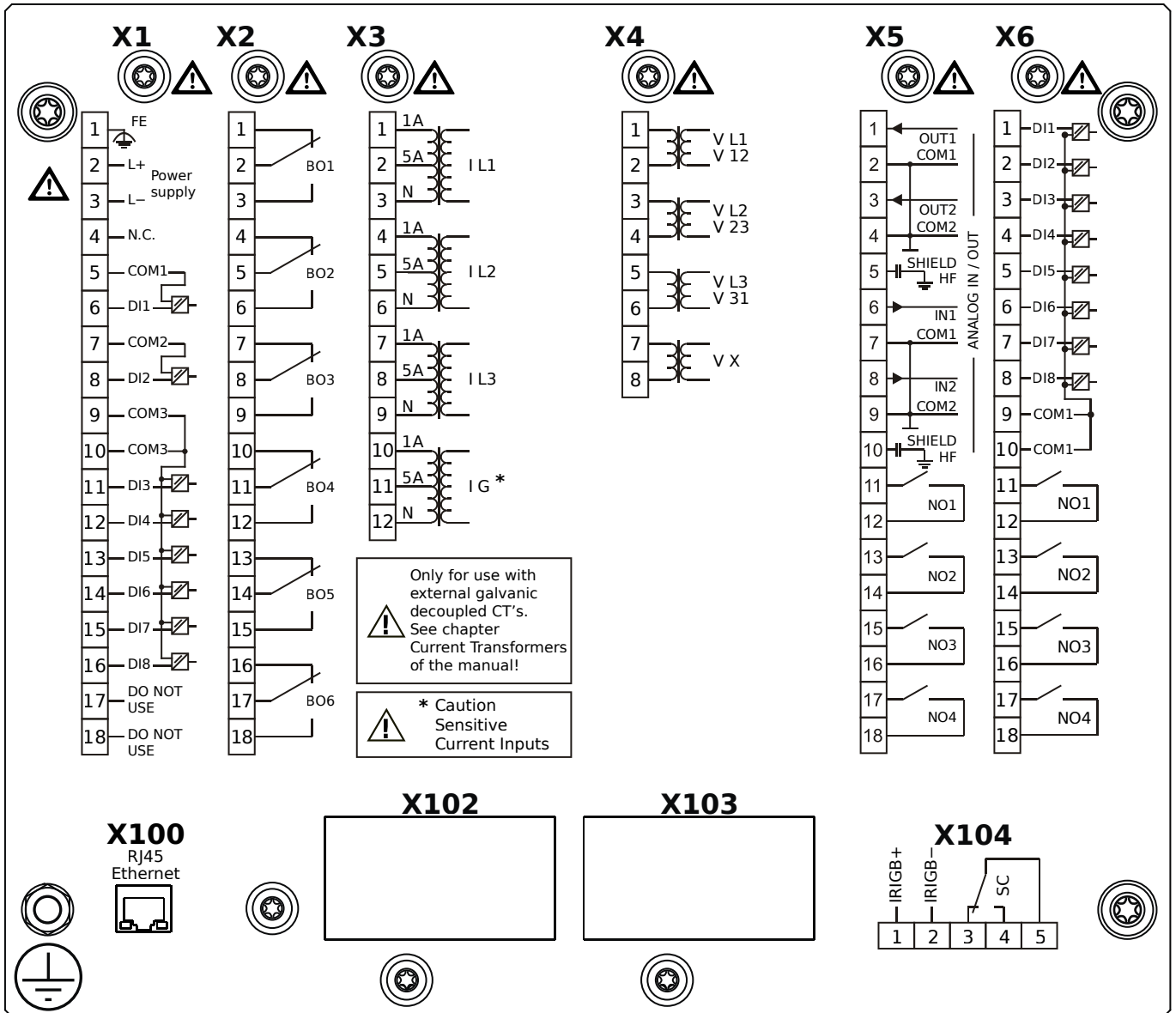

Housing B2, small display, 19" rack mounting

- X1** – DI8-X1: Wide-range power supply unit, incl. 2 non-grouped digital inputs and 6 grouped digital inputs
- X2** – OR6: Assembly Group with 6 Output Relays (Changeover / Form C)
- X3** – TIs: Standard phase current measuring card and sensitive ground current measuring
- X4** – TU: Card with 4 voltage transformer measuring inputs (0 ... 800 VAC, under UL: 0 ... 600 VAC)
- X5** – AnIO2-OR4: Assembly Group with 2 Analog Inputs, 2 Analog Outputs and 4 Output Relays
- X6** – DI8-OR4: Assembly Group with 8 Digital Inputs and 4 Output Relays (NO / Form A)
- X100** – Modbus TCP / DNP3.0 TCP/UDP, Ethernet interface, 100 Mbit/s, RJ45 (BASE100-FX)
- X104** – IRIG-B00X, incl. System Contact (Supervision Contact)

MRA4-2F1BCB

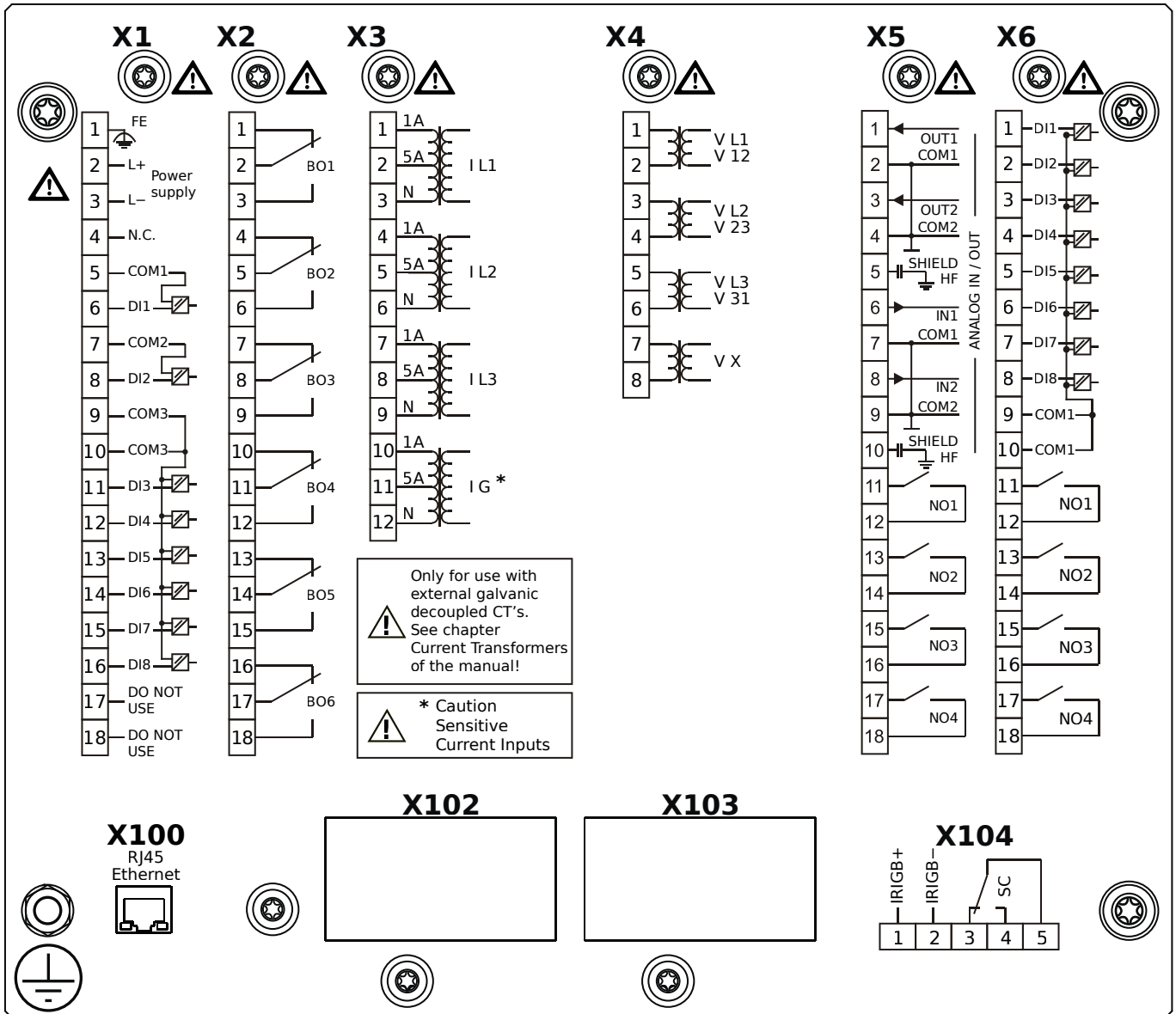

Housing B2, small display, 19" rack mounting

+ Conformal Coating (for installations in harsh environment)

- X1** – DI8-X1: Wide-range power supply unit, incl. 2 non-grouped digital inputs and 6 grouped digital inputs
- X2** – OR6: Assembly Group with 6 Output Relays (Changeover / Form C)
- X3** – TIs: Standard phase current measuring card and sensitive ground current measuring
- X4** – TU: Card with 4 voltage transformer measuring inputs (0 ... 800 VAC, under UL: 0 ... 600 VAC)
- X5** – AnIO2-OR4: Assembly Group with 2 Analog Inputs, 2 Analog Outputs and 4 Output Relays
- X6** – DI8-OR4: Assembly Group with 8 Digital Inputs and 4 Output Relays (NO / Form A)
- X100** – Modbus TCP / DNP3.0 TCP/UDP, Ethernet interface, 100 Mbit/s, RJ45 (BASE100-FX)
- X104** – IRIG-B00X, incl. System Contact (Supervision Contact)

MRA4-2F1BDA

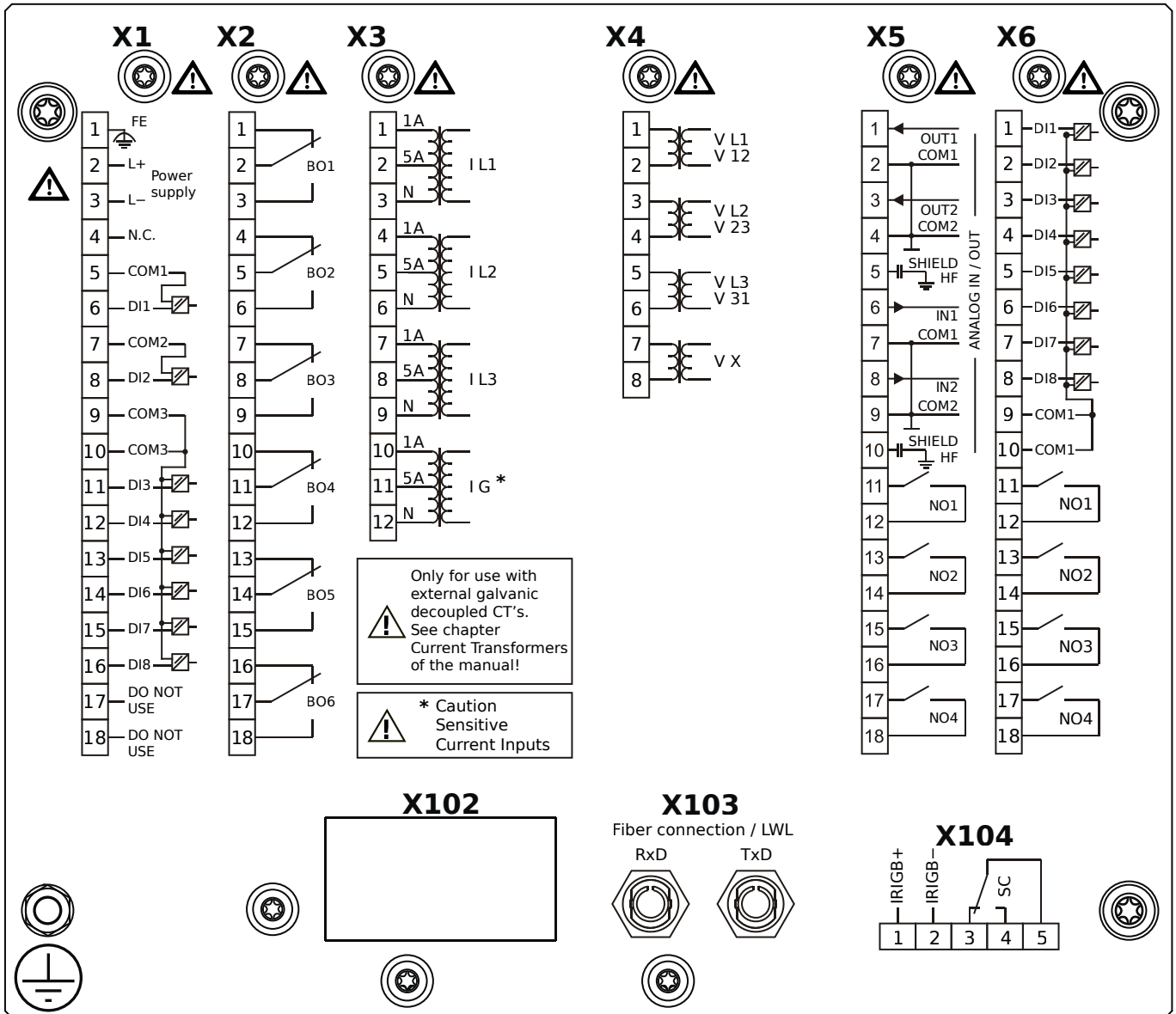

Housing B2, small display, 19" rack mounting

- X1** – DI8-X1: Wide-range power supply unit, incl. 2 non-grouped digital inputs and 6 grouped digital inputs
- X2** – OR6: Assembly Group with 6 Output Relays (Changeover / Form C)
- X3** – TIs: Standard phase current measuring card and sensitive ground current measuring
- X4** – TU: Card with 4 voltage transformer measuring inputs (0 ... 800 VAC, under UL: 0 ... 600 VAC)
- X5** – AnIO2-OR4: Assembly Group with 2 Analog Inputs, 2 Analog Outputs and 4 Output Relays
- X6** – DI8-OR4: Assembly Group with 8 Digital Inputs and 4 Output Relays (NO / Form A)
- X103** – Profibus-DP, Fiber optics interface, ST Connector
- X104** – IRIG-B00X, incl. System Contact (Supervision Contact)

MRA4-2F1BDB

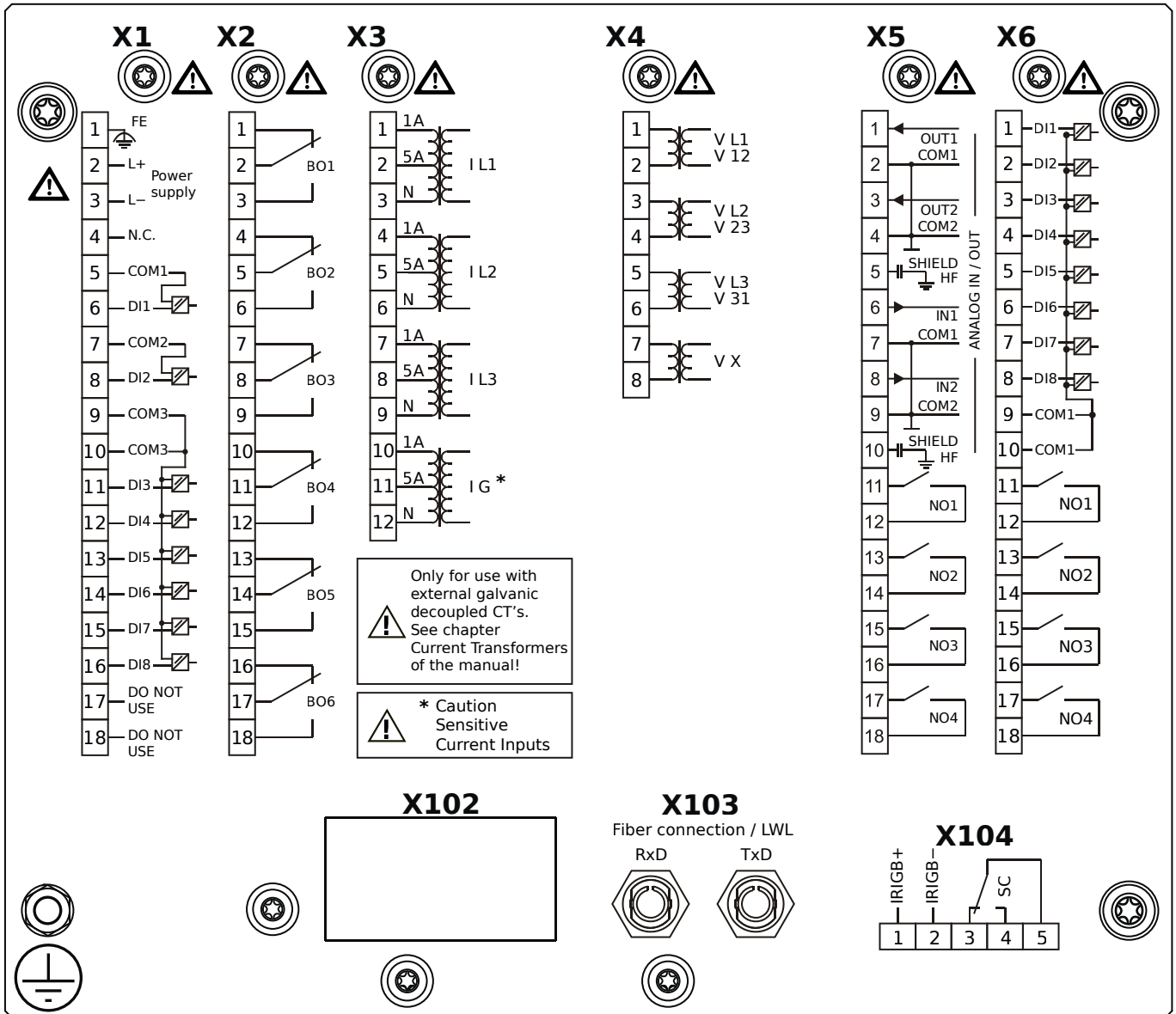

Housing B2, small display, 19" rack mounting

+ Conformal Coating (for installations in harsh environment)

- X1** – DI8-X1: Wide-range power supply unit, incl. 2 non-grouped digital inputs and 6 grouped digital inputs
- X2** – OR6: Assembly Group with 6 Output Relays (Changeover / Form C)
- X3** – TIs: Standard phase current measuring card and sensitive ground current measuring
- X4** – TU: Card with 4 voltage transformer measuring inputs (0 ... 800 VAC, under UL: 0 ... 600 VAC)
- X5** – AnIO2-OR4: Assembly Group with 2 Analog Inputs, 2 Analog Outputs and 4 Output Relays
- X6** – DI8-OR4: Assembly Group with 8 Digital Inputs and 4 Output Relays (NO / Form A)
- X103** – Profibus-DP, Fiber optics interface, ST Connector
- X104** – IRIG-B00X, incl. System Contact (Supervision Contact)

MRA4-2F1BEA

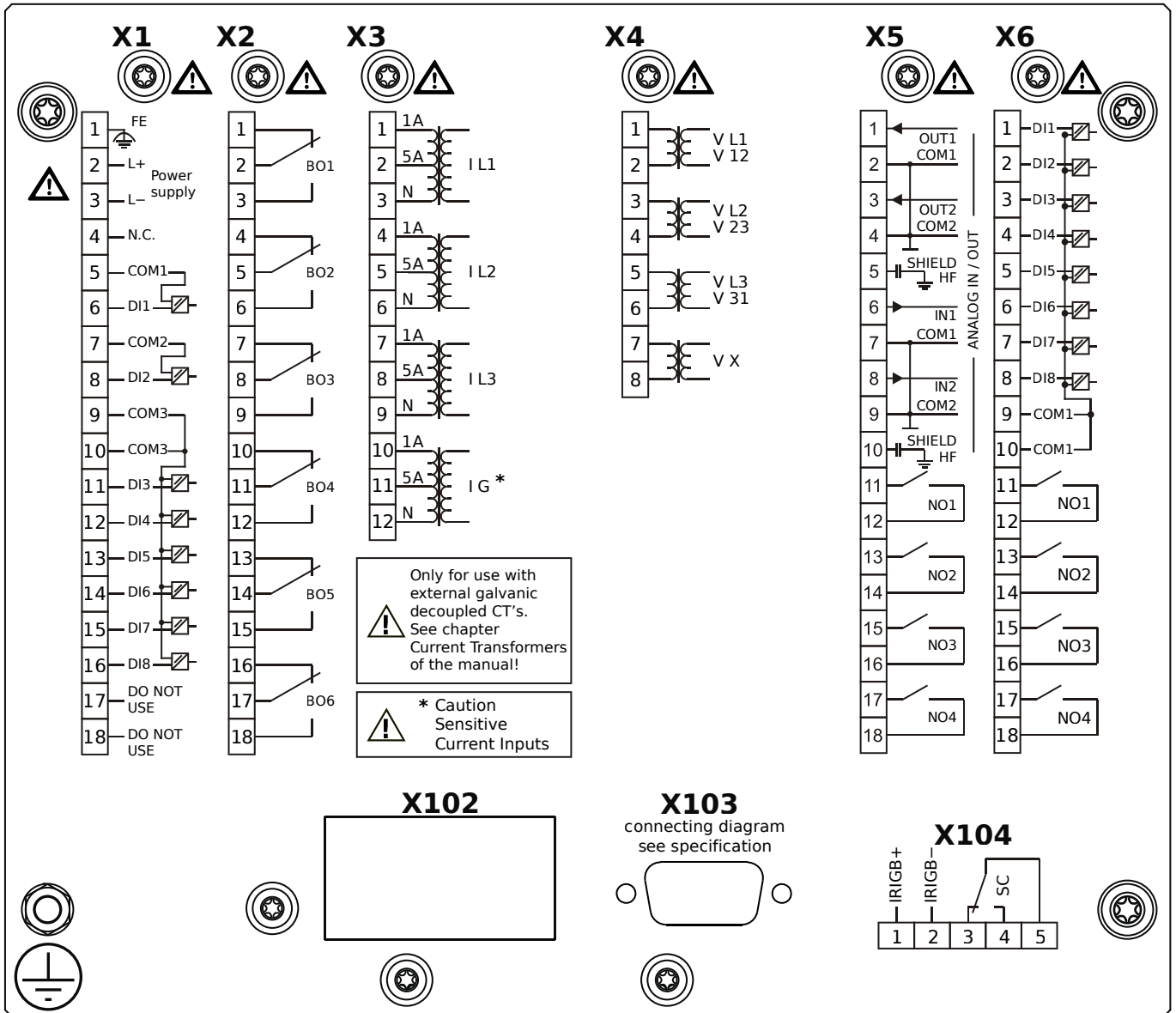

Housing B2, small display, 19" rack mounting

- X1** – DI8-X1: Wide-range power supply unit, incl. 2 non-grouped digital inputs and 6 grouped digital inputs
- X2** – OR6: Assembly Group with 6 Output Relays (Changeover / Form C)
- X3** – TIs: Standard phase current measuring card and sensitive ground current measuring
- X4** – TU: Card with 4 voltage transformer measuring inputs (0 ... 800 VAC, under UL: 0 ... 600 VAC)
- X5** – AnIO2-OR4: Assembly Group with 2 Analog Inputs, 2 Analog Outputs and 4 Output Relays
- X6** – DI8-OR4: Assembly Group with 8 Digital Inputs and 4 Output Relays (NO / Form A)
- X103** – Profibus-DP, RS485, D-SUB
- X104** – IRIG-B00X, incl. System Contact (Supervision Contact)

MRA4-2F1BEB

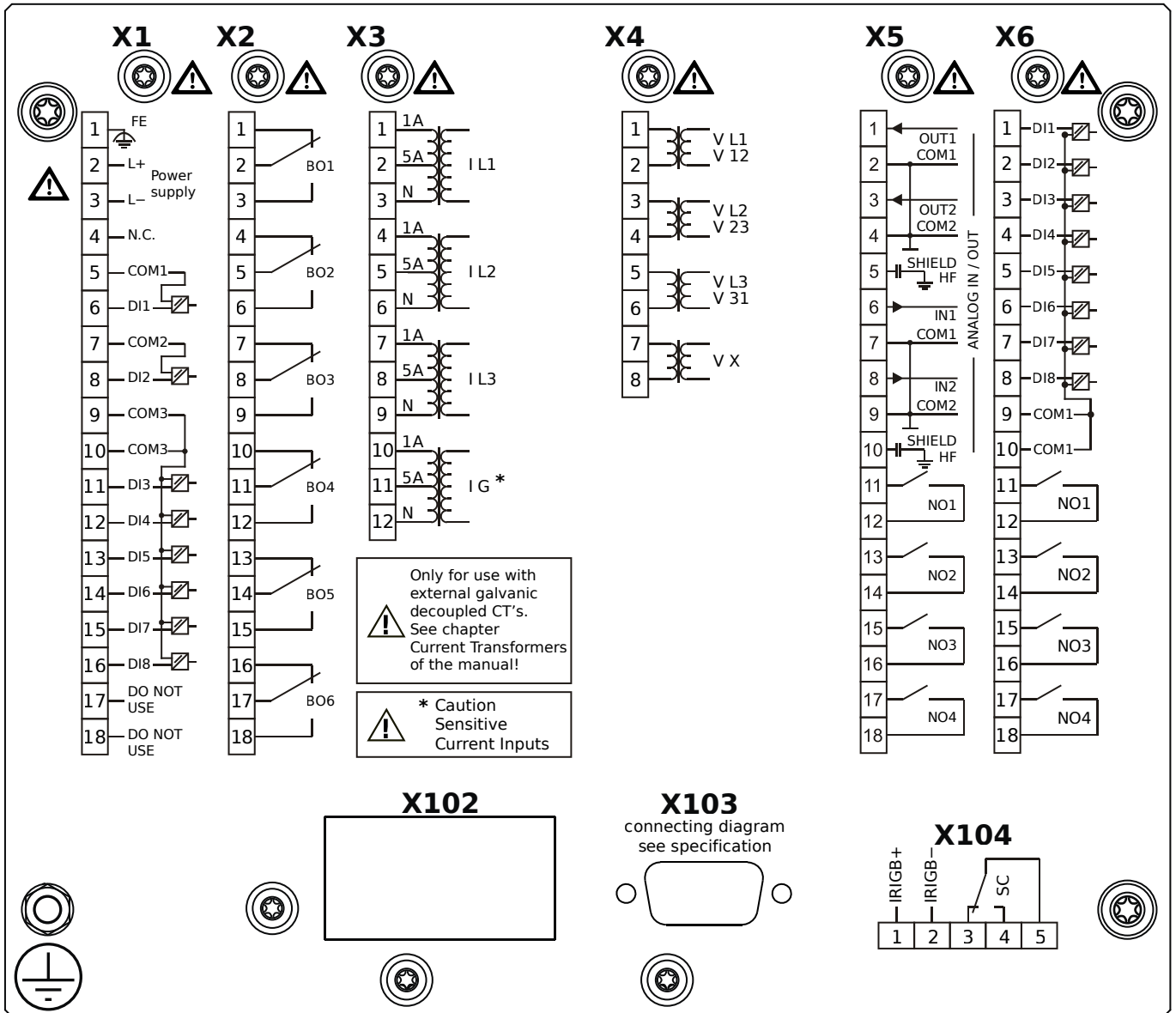

Housing B2, small display, 19" rack mounting

+ Conformal Coating (for installations in harsh environment)

- X1** – DI8-X1: Wide-range power supply unit, incl. 2 non-grouped digital inputs and 6 grouped digital inputs
- X2** – OR6: Assembly Group with 6 Output Relays (Changeover / Form C)
- X3** – TIs: Standard phase current measuring card and sensitive ground current measuring
- X4** – TU: Card with 4 voltage transformer measuring inputs (0 ... 800 VAC, under UL: 0 ... 600 VAC)
- X5** – AnIO2-OR4: Assembly Group with 2 Analog Inputs, 2 Analog Outputs and 4 Output Relays
- X6** – DI8-OR4: Assembly Group with 8 Digital Inputs and 4 Output Relays (NO / Form A)
- X103** – Profibus-DP, RS485, D-SUB
- X104** – IRIG-B00X, incl. System Contact (Supervision Contact)

MRA4-2F1BFA

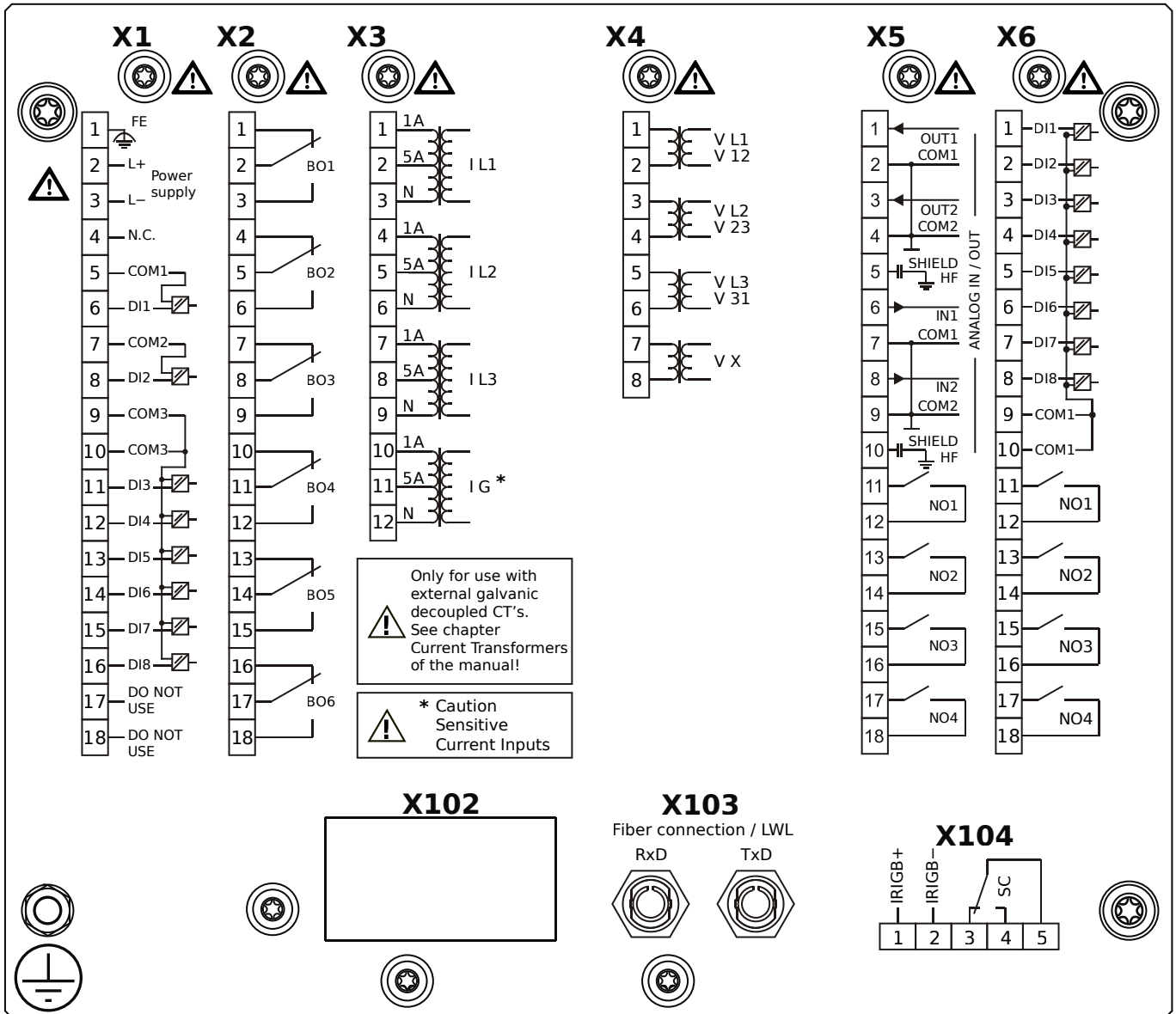

Housing B2, small display, 19" rack mounting

- X1** – DI8-X1: Wide-range power supply unit, incl. 2 non-grouped digital inputs and 6 grouped digital inputs
- X2** – OR6: Assembly Group with 6 Output Relays (Changeover / Form C)
- X3** – TIs: Standard phase current measuring card and sensitive ground current measuring
- X4** – TU: Card with 4 voltage transformer measuring inputs (0 ... 800 VAC, under UL: 0 ... 600 VAC)
- X5** – AnIO2-OR4: Assembly Group with 2 Analog Inputs, 2 Analog Outputs and 4 Output Relays
- X6** – DI8-OR4: Assembly Group with 8 Digital Inputs and 4 Output Relays (NO / Form A)
- X103** – Modbus RTU / IEC 60870-5-103 / DNP3.0 RTU, Fiber optics interface, ST Connector
- X104** – IRIG-B00X, incl. System Contact (Supervision Contact)

MRA4-2F1BFB

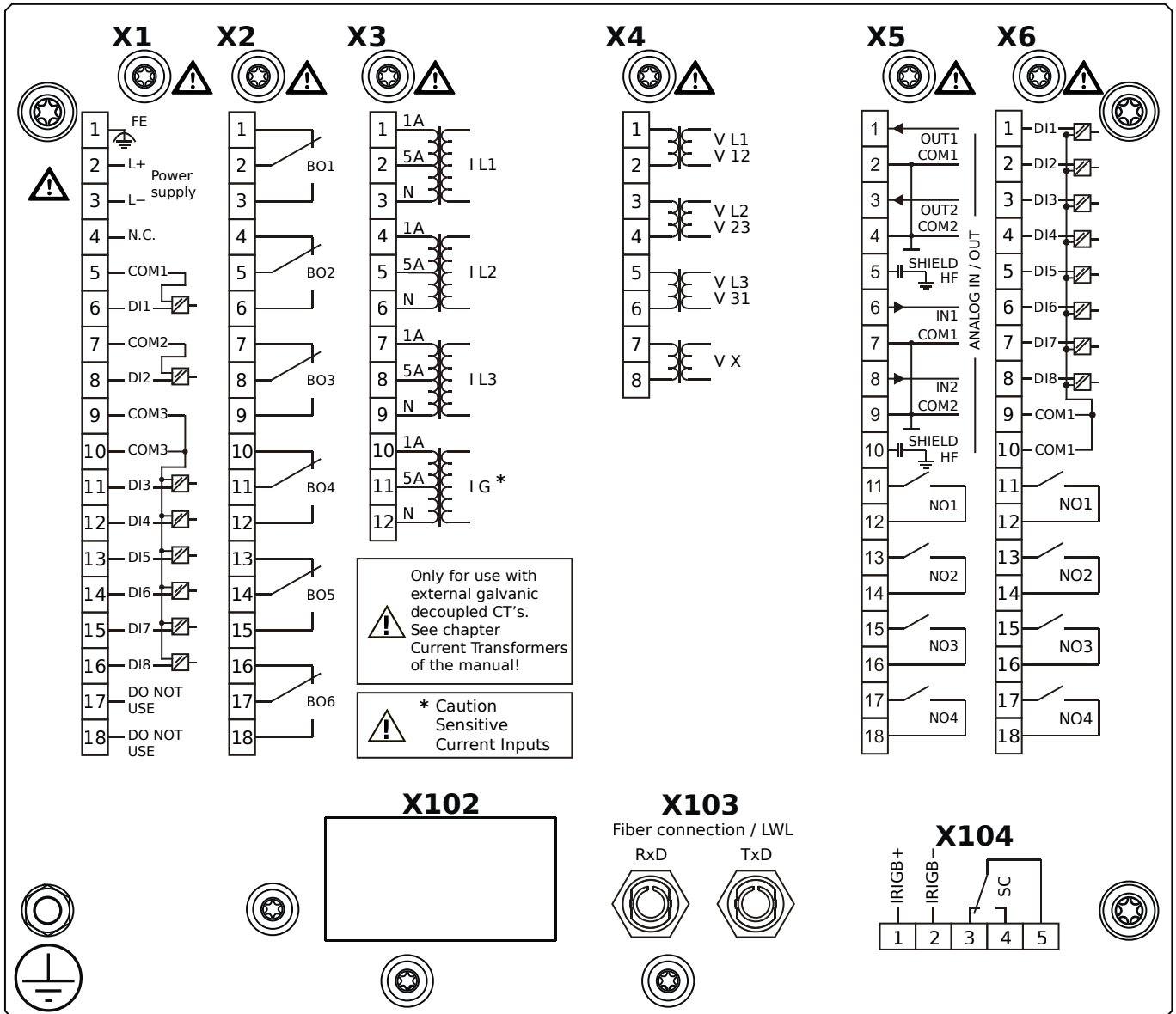

Housing B2, small display, 19" rack mounting

+ Conformal Coating (for installations in harsh environment)

- X1** – DI8-X1: Wide-range power supply unit, incl. 2 non-grouped digital inputs and 6 grouped digital inputs
- X2** – OR6: Assembly Group with 6 Output Relays (Changeover / Form C)
- X3** – TIs: Standard phase current measuring card and sensitive ground current measuring
- X4** – TU: Card with 4 voltage transformer measuring inputs (0 ... 800 VAC, under UL: 0 ... 600 VAC)
- X5** – AnIO2-OR4: Assembly Group with 2 Analog Inputs, 2 Analog Outputs and 4 Output Relays
- X6** – DI8-OR4: Assembly Group with 8 Digital Inputs and 4 Output Relays (NO / Form A)
- X103** – Modbus RTU / IEC 60870-5-103 / DNP3.0 RTU, Fiber optics interface, ST Connector
- X104** – IRIG-B00X, incl. System Contact (Supervision Contact)

MRA4-2F1BGA

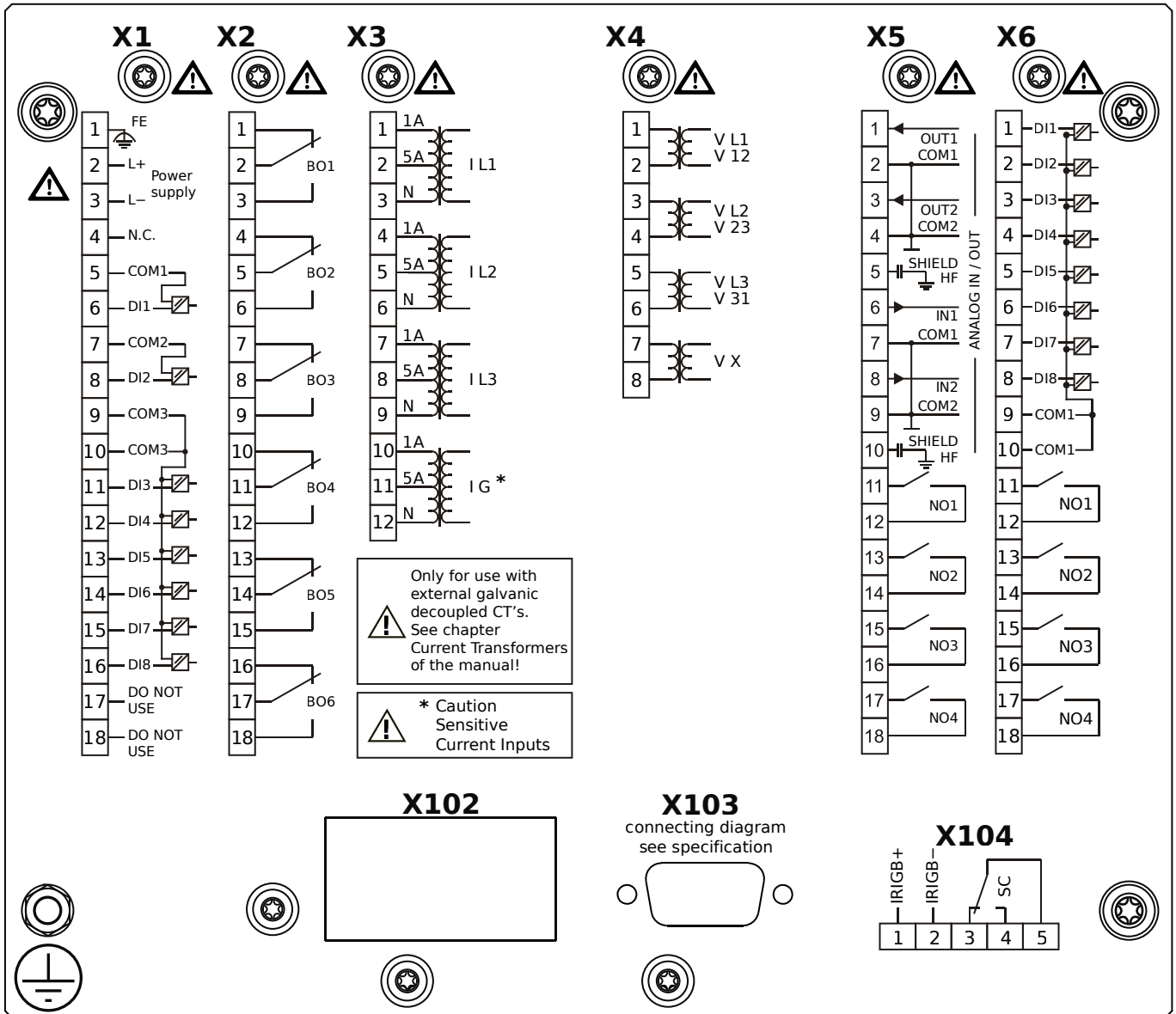

Housing B2, small display, 19" rack mounting

- X1** – DI8-X1: Wide-range power supply unit, incl. 2 non-grouped digital inputs and 6 grouped digital inputs
- X2** – OR6: Assembly Group with 6 Output Relays (Changeover / Form C)
- X3** – TIs: Standard phase current measuring card and sensitive ground current measuring
- X4** – TU: Card with 4 voltage transformer measuring inputs (0 ... 800 VAC, under UL: 0 ... 600 VAC)
- X5** – AnIO2-OR4: Assembly Group with 2 Analog Inputs, 2 Analog Outputs and 4 Output Relays
- X6** – DI8-OR4: Assembly Group with 8 Digital Inputs and 4 Output Relays (NO / Form A)
- X103** – Modbus RTU / IEC 60870-5-103 / DNP3.0 RTU, RS485, D-SUB
- X104** – IRIG-B00X, incl. System Contact (Supervision Contact)

MRA4-2F1BGB

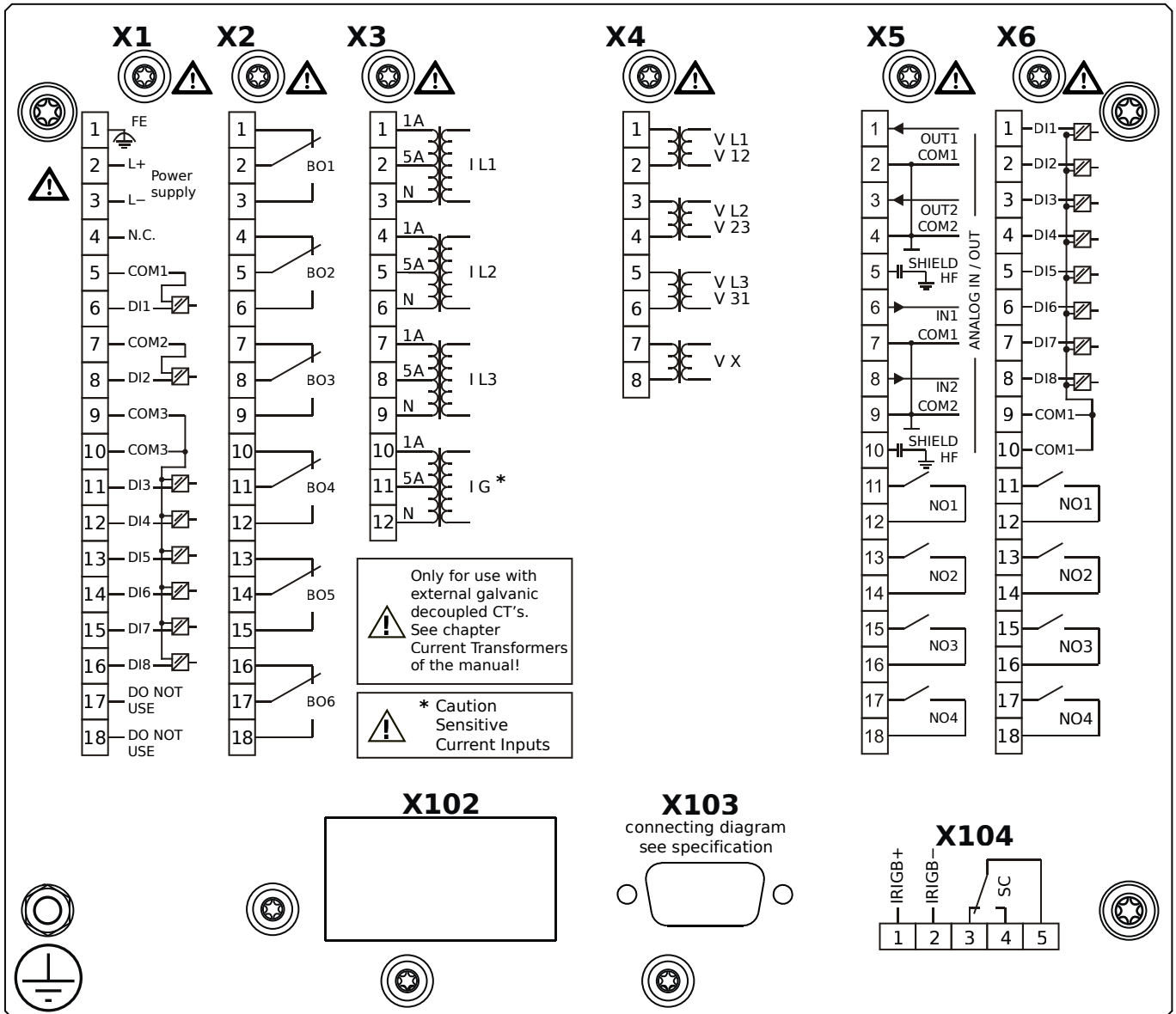

Housing B2, small display, 19" rack mounting

+ Conformal Coating (for installations in harsh environment)

- X1** – DI8-X1: Wide-range power supply unit, incl. 2 non-grouped digital inputs and 6 grouped digital inputs
- X2** – OR6: Assembly Group with 6 Output Relays (Changeover / Form C)
- X3** – TIs: Standard phase current measuring card and sensitive ground current measuring
- X4** – TU: Card with 4 voltage transformer measuring inputs (0 ... 800 VAC, under UL: 0 ... 600 VAC)
- X5** – AnIO2-OR4: Assembly Group with 2 Analog Inputs, 2 Analog Outputs and 4 Output Relays
- X6** – DI8-OR4: Assembly Group with 8 Digital Inputs and 4 Output Relays (NO / Form A)
- X103** – Modbus RTU / IEC 60870-5-103 / DNP3.0 RTU, RS485, D-SUB
- X104** – IRIG-B00X, incl. System Contact (Supervision Contact)

MRA4-2F1BHA

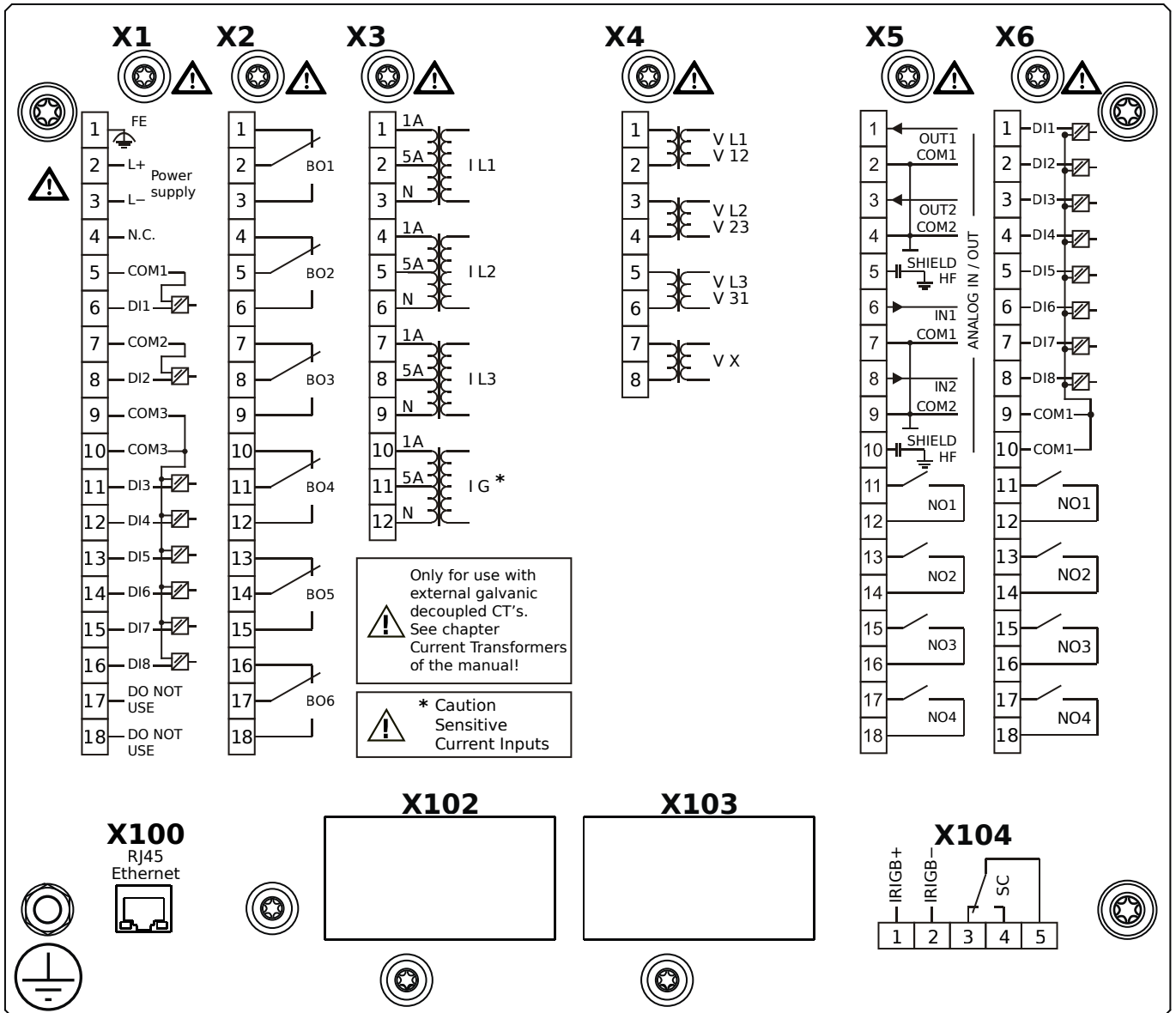

Housing B2, small display, 19" rack mounting

- X1** – DI8-X1: Wide-range power supply unit, incl. 2 non-grouped digital inputs and 6 grouped digital inputs
- X2** – OR6: Assembly Group with 6 Output Relays (Changeover / Form C)
- X3** – TIs: Standard phase current measuring card and sensitive ground current measuring
- X4** – TU: Card with 4 voltage transformer measuring inputs (0 ... 800 VAC, under UL: 0 ... 600 VAC)
- X5** – AnIO2-OR4: Assembly Group with 2 Analog Inputs, 2 Analog Outputs and 4 Output Relays
- X6** – DI8-OR4: Assembly Group with 8 Digital Inputs and 4 Output Relays (NO / Form A)
- X100** – IEC 61850 / Modbus TCP / DNP3.0 TCP/UDP, Ethernet interface, 100 Mbit/s, RJ45 (BASE100-FX)
- X104** – IRIG-B00X, incl. System Contact (Supervision Contact)

MRA4-2F1BHB

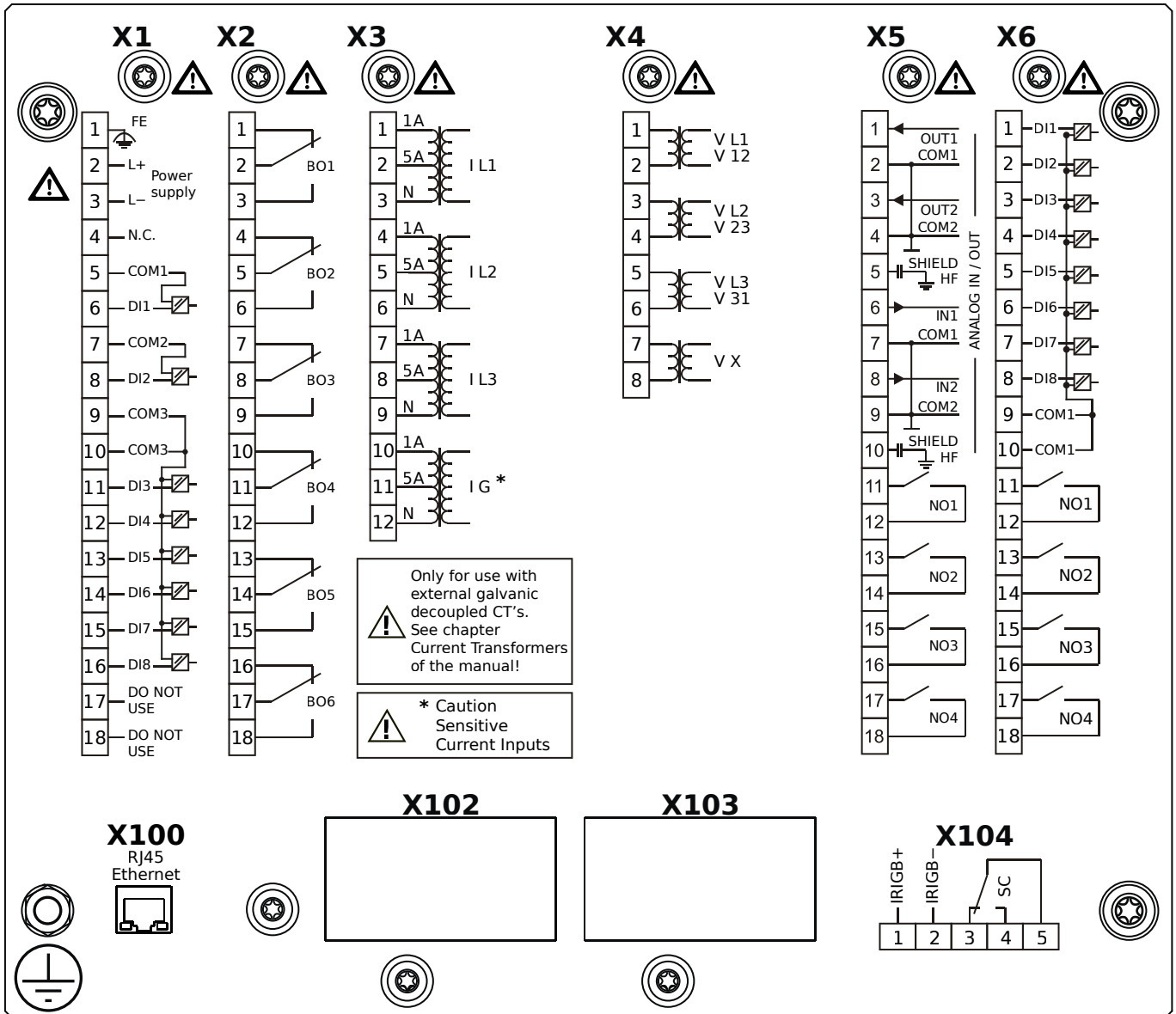

Housing B2, small display, 19" rack mounting

+ Conformal Coating (for installations in harsh environment)

- X1** – DI8-X1: Wide-range power supply unit, incl. 2 non-grouped digital inputs and 6 grouped digital inputs
- X2** – OR6: Assembly Group with 6 Output Relays (Changeover / Form C)
- X3** – TIs: Standard phase current measuring card and sensitive ground current measuring
- X4** – TU: Card with 4 voltage transformer measuring inputs (0 ... 800 VAC, under UL: 0 ... 600 VAC)
- X5** – AnIO2-OR4: Assembly Group with 2 Analog Inputs, 2 Analog Outputs and 4 Output Relays
- X6** – DI8-OR4: Assembly Group with 8 Digital Inputs and 4 Output Relays (NO / Form A)
- X100** – IEC 61850 / Modbus TCP / DNP3.0 TCP/UDP, Ethernet interface, 100 Mbit/s, RJ45 (BASE100-FX)
- X104** – IRIG-B00X, incl. System Contact (Supervision Contact)

MRA4-2F1BIA

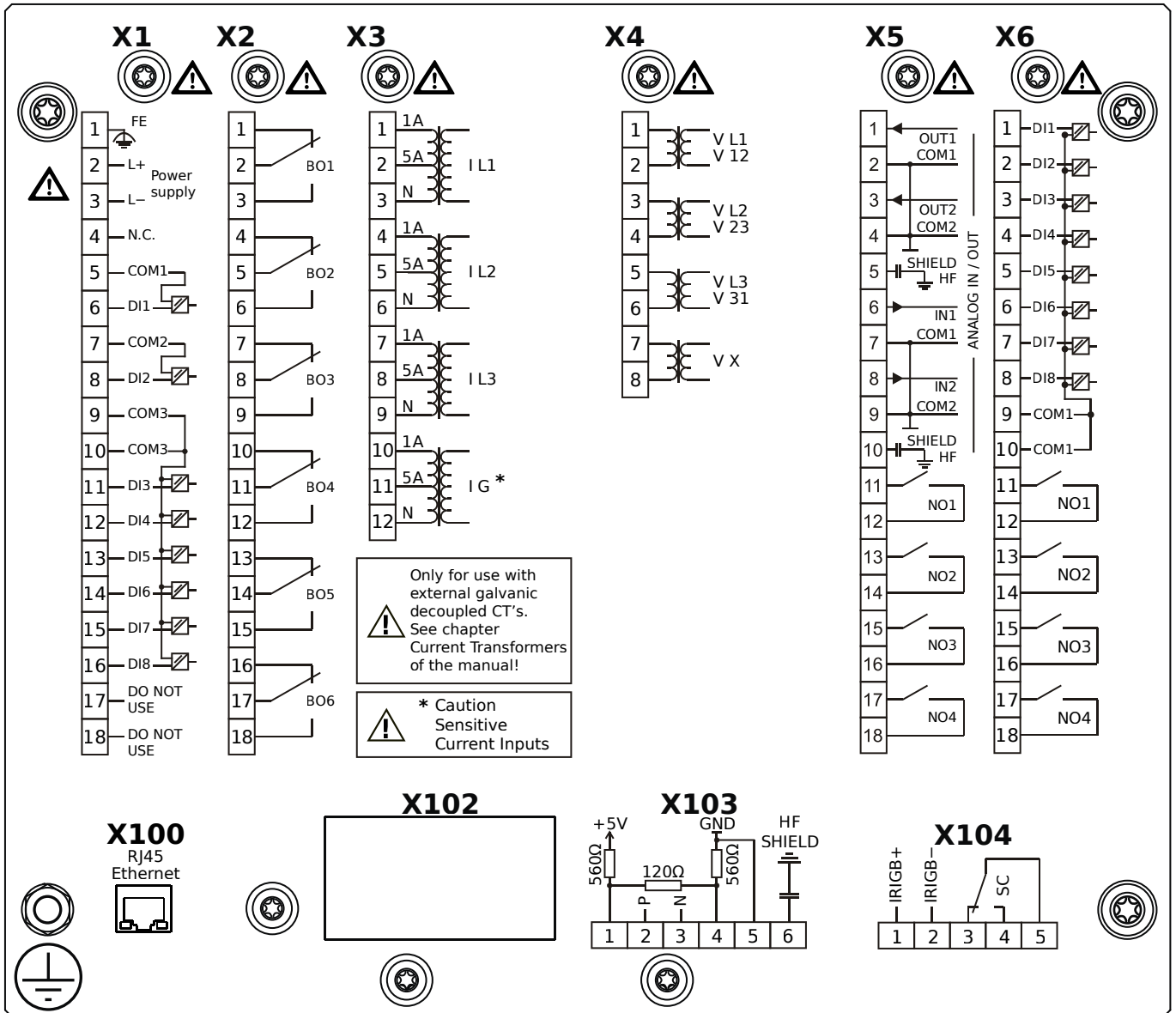

Housing B2, small display, 19" rack mounting

- X1** – DI8-X1: Wide-range power supply unit, incl. 2 non-grouped digital inputs and 6 grouped digital inputs
- X2** – OR6: Assembly Group with 6 Output Relays (Changeover / Form C)
- X3** – TIs: Standard phase current measuring card and sensitive ground current measuring
- X4** – TU: Card with 4 voltage transformer measuring inputs (0 ... 800 VAC, under UL: 0 ... 600 VAC)
- X5** – AnIO2-OR4: Assembly Group with 2 Analog Inputs, 2 Analog Outputs and 4 Output Relays
- X6** – DI8-OR4: Assembly Group with 8 Digital Inputs and 4 Output Relays (NO / Form A)
- X100** – Modbus TCP / DNP3.0 TCP/UDP, Ethernet interface, 100 Mbit/s, RJ45 (BASE100-FX)
- X103** – IEC 60870-5-103 / Modbus RTU / DNP3.0 RTU, RS485, Terminals
- X104** – IRIG-B00X, incl. System Contact (Supervision Contact)

MRA4-2F1BIB

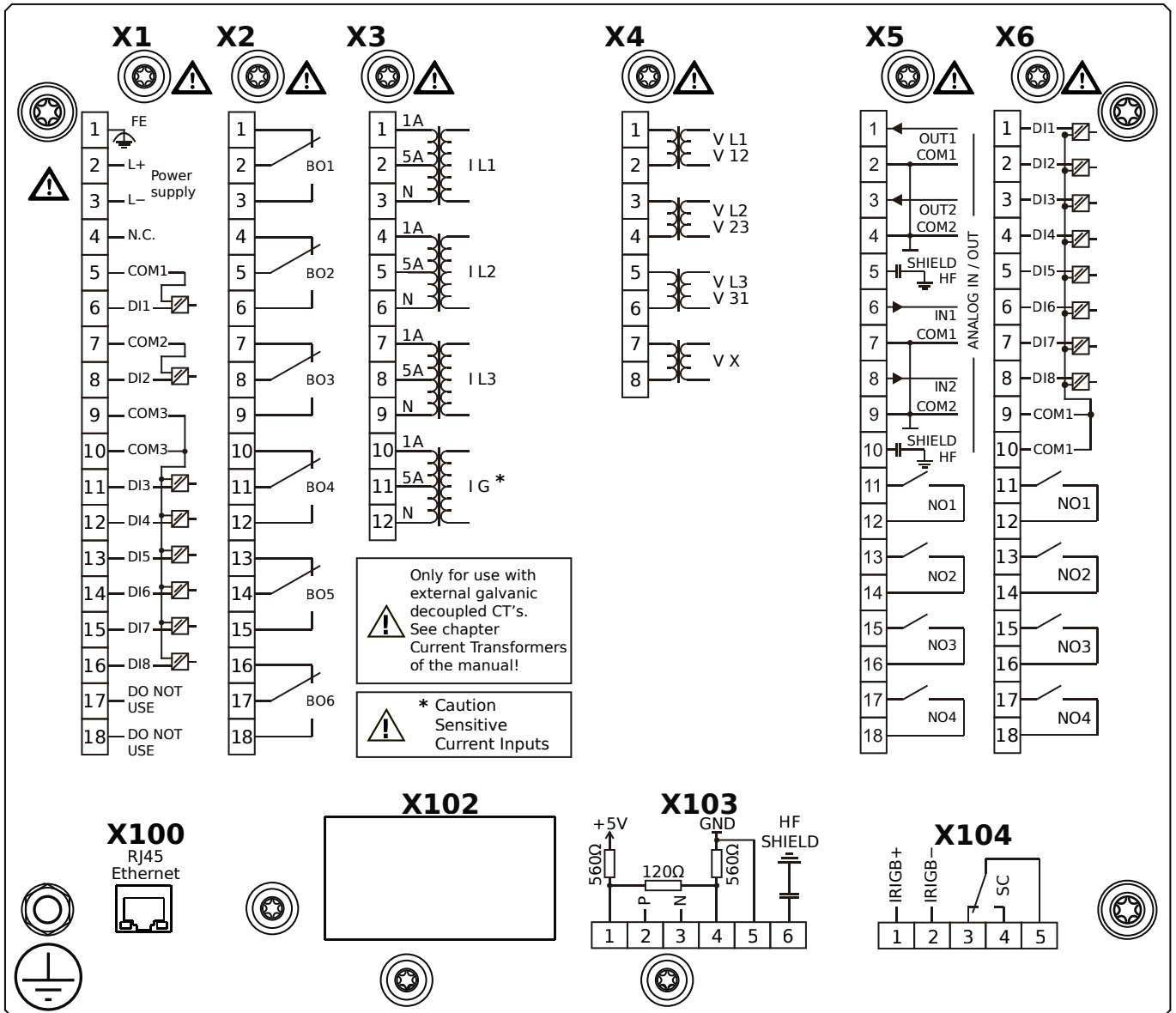

Housing B2, small display, 19" rack mounting

+ Conformal Coating (for installations in harsh environment)

- X1** – DI8-X1: Wide-range power supply unit, incl. 2 non-grouped digital inputs and 6 grouped digital inputs
- X2** – OR6: Assembly Group with 6 Output Relays (Changeover / Form C)
- X3** – TIs: Standard phase current measuring card and sensitive ground current measuring
- X4** – TU: Card with 4 voltage transformer measuring inputs (0 ... 800 VAC, under UL: 0 ... 600 VAC)
- X5** – AnIO2-OR4: Assembly Group with 2 Analog Inputs, 2 Analog Outputs and 4 Output Relays
- X6** – DI8-OR4: Assembly Group with 8 Digital Inputs and 4 Output Relays (NO / Form A)
- X100** – Modbus TCP / DNP3.0 TCP/UDP, Ethernet interface, 100 Mbit/s, RJ45 (BASE100-FX)
- X103** – IEC 60870-5-103 / Modbus RTU / DNP3.0 RTU, RS485, Terminals
- X104** – IRIG-B00X, incl. System Contact (Supervision Contact)

MRA4-2F1BKA

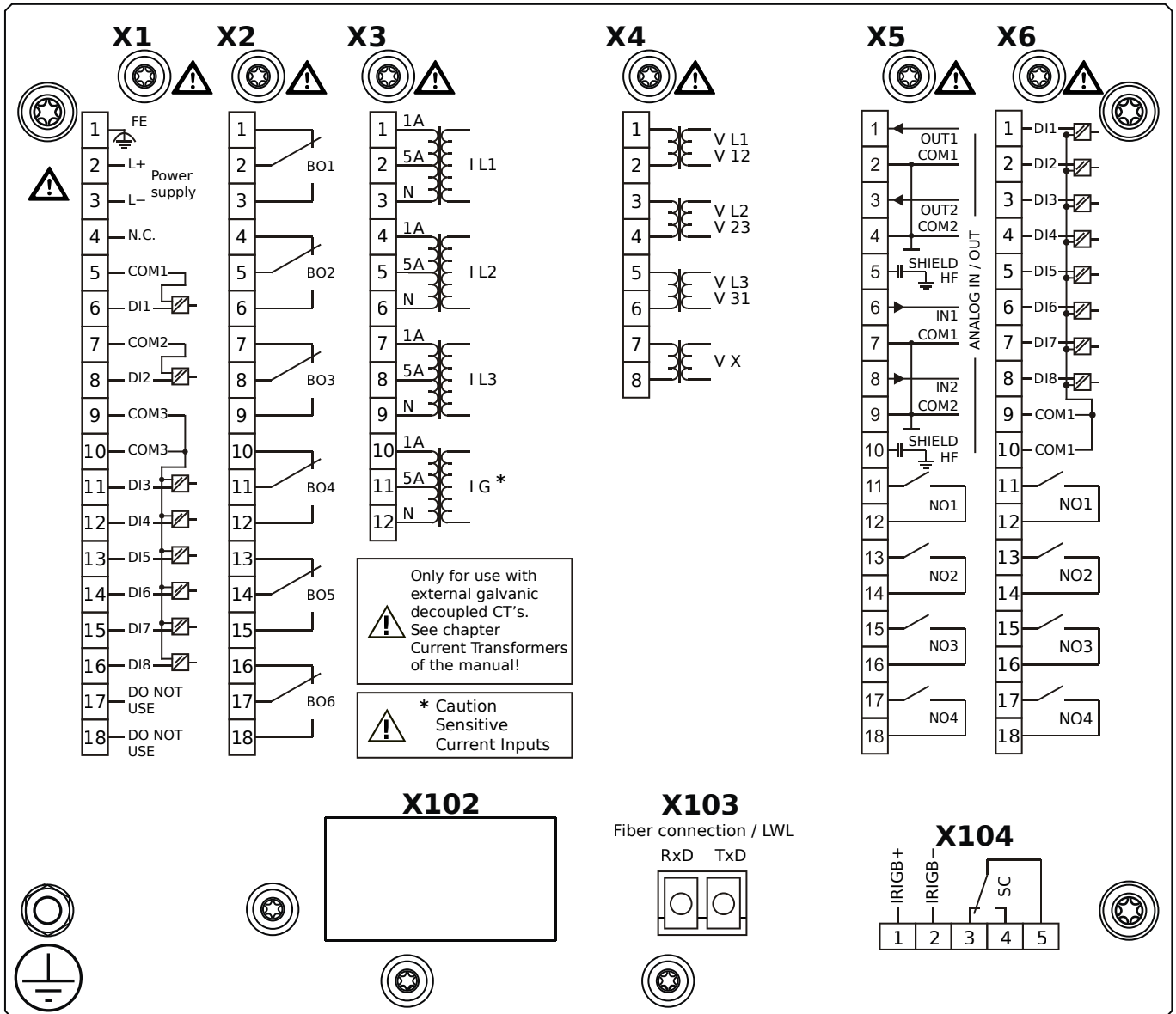

Housing B2, small display, 19" rack mounting

- X1** – DI8-X1: Wide-range power supply unit, incl. 2 non-grouped digital inputs and 6 grouped digital inputs
- X2** – OR6: Assembly Group with 6 Output Relays (Changeover / Form C)
- X3** – TIs: Standard phase current measuring card and sensitive ground current measuring
- X4** – TU: Card with 4 voltage transformer measuring inputs (0 ... 800 VAC, under UL: 0 ... 600 VAC)
- X5** – AnIO2-OR4: Assembly Group with 2 Analog Inputs, 2 Analog Outputs and 4 Output Relays
- X6** – DI8-OR4: Assembly Group with 8 Digital Inputs and 4 Output Relays (NO / Form A)
- X103** – IEC 61850 / Modbus TCP / DNP3.0 TCP/UDP, Fiber optics interface, LC Connector
- X104** – IRIG-B00X, incl. System Contact (Supervision Contact)

MRA4-2F1BKB

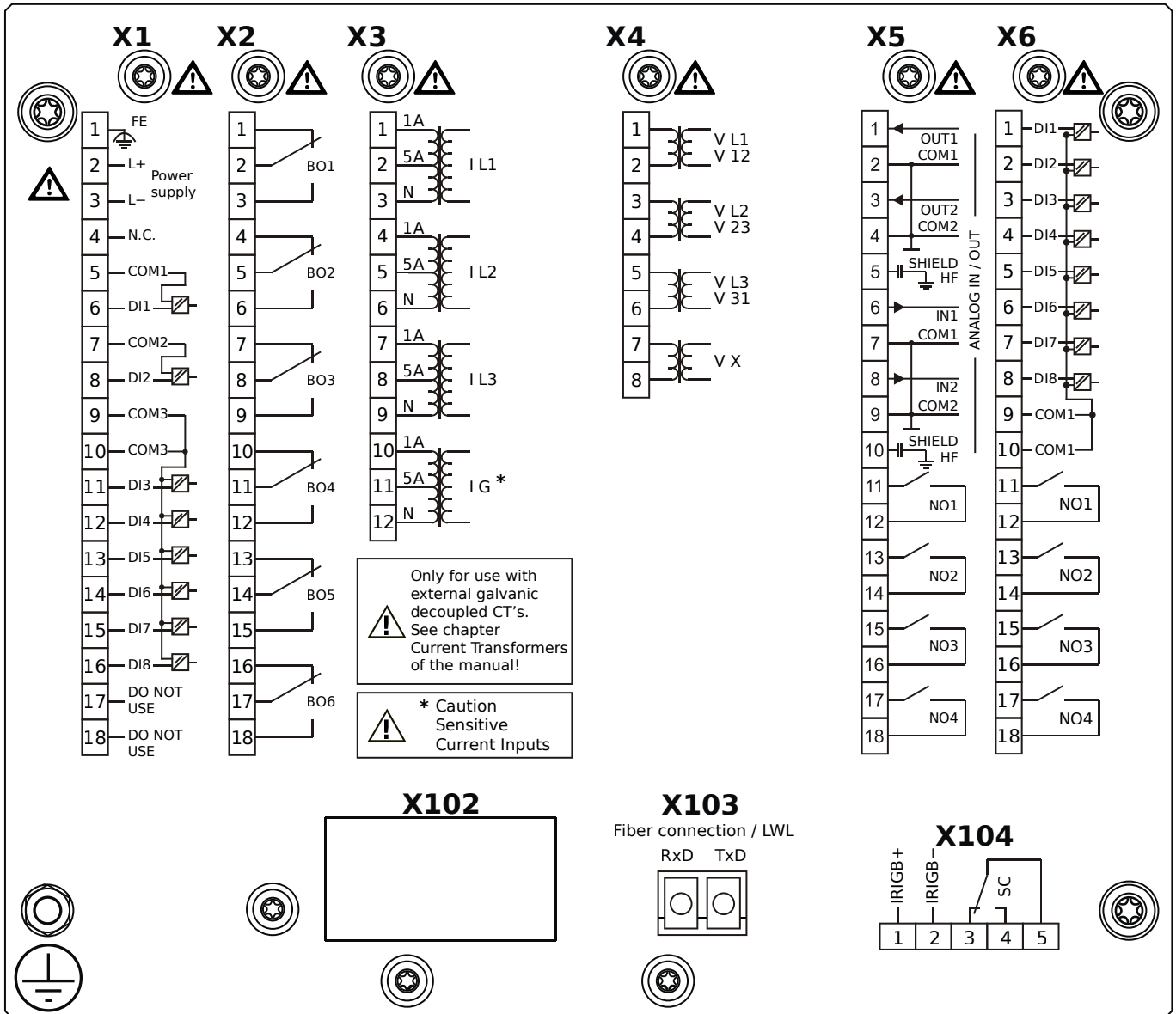

Housing B2, small display, 19" rack mounting

+ Conformal Coating (for installations in harsh environment)

- X1** – DI8-X1: Wide-range power supply unit, incl. 2 non-grouped digital inputs and 6 grouped digital inputs
- X2** – OR6: Assembly Group with 6 Output Relays (Changeover / Form C)
- X3** – TIs: Standard phase current measuring card and sensitive ground current measuring
- X4** – TU: Card with 4 voltage transformer measuring inputs (0 ... 800 VAC, under UL: 0 ... 600 VAC)
- X5** – AnIO2-OR4: Assembly Group with 2 Analog Inputs, 2 Analog Outputs and 4 Output Relays
- X6** – DI8-OR4: Assembly Group with 8 Digital Inputs and 4 Output Relays (NO / Form A)
- X103** – IEC 61850 / Modbus TCP / DNP3.0 TCP/UDP, Fiber optics interface, LC Connector
- X104** – IRIG-B00X, incl. System Contact (Supervision Contact)

MRA4-2F1BLA

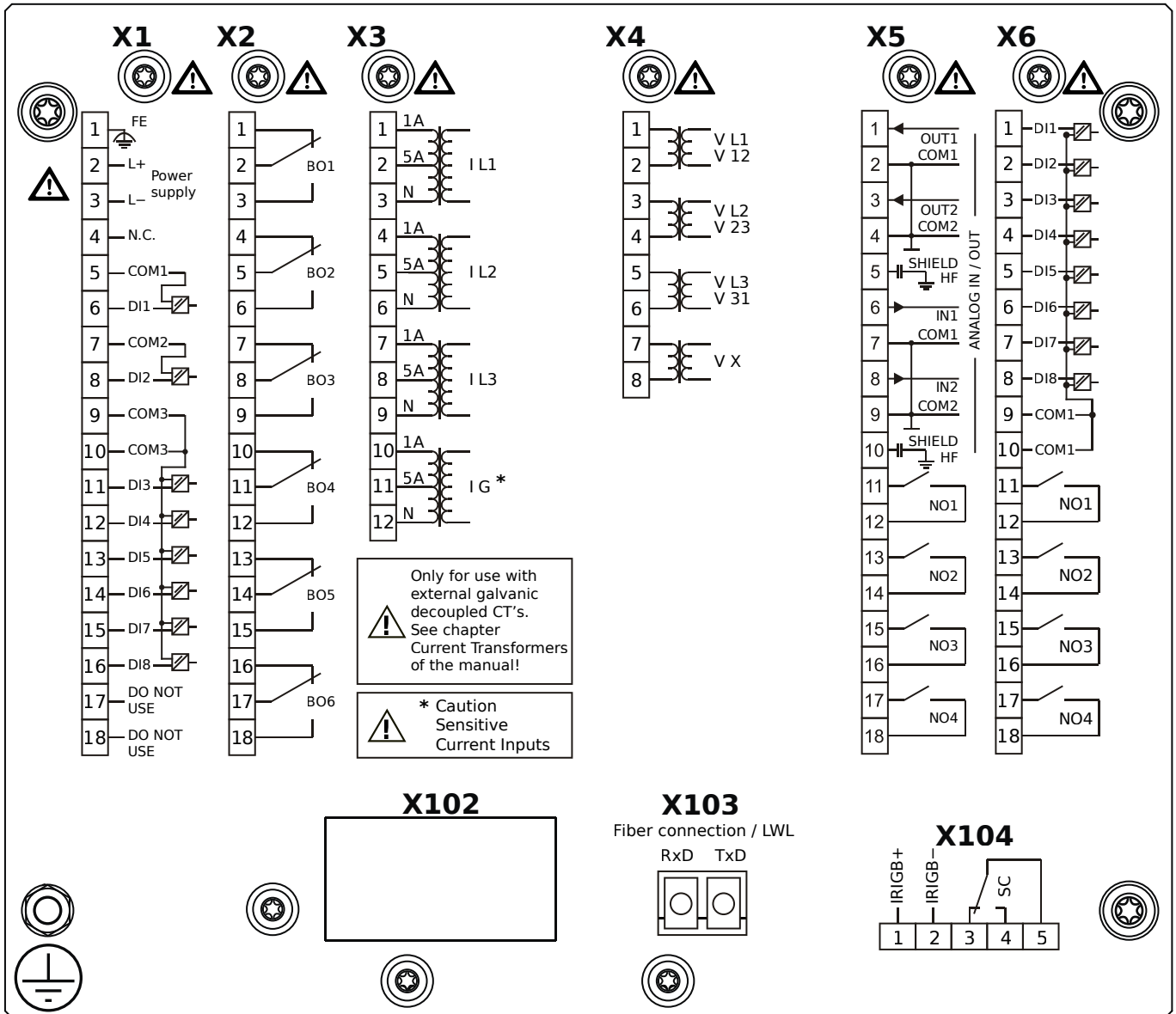

Housing B2, small display, 19" rack mounting

- X1** – DI8-X1: Wide-range power supply unit, incl. 2 non-grouped digital inputs and 6 grouped digital inputs
- X2** – OR6: Assembly Group with 6 Output Relays (Changeover / Form C)
- X3** – TIs: Standard phase current measuring card and sensitive ground current measuring
- X4** – TU: Card with 4 voltage transformer measuring inputs (0 ... 800 VAC, under UL: 0 ... 600 VAC)
- X5** – AnIO2-OR4: Assembly Group with 2 Analog Inputs, 2 Analog Outputs and 4 Output Relays
- X6** – DI8-OR4: Assembly Group with 8 Digital Inputs and 4 Output Relays (NO / Form A)
- X103** – Modbus TCP / DNP3.0 TCP/UDP, Fiber optics interface, LC Connector
- X104** – IRIG-B00X, incl. System Contact (Supervision Contact)

MRA4-2F1BLB

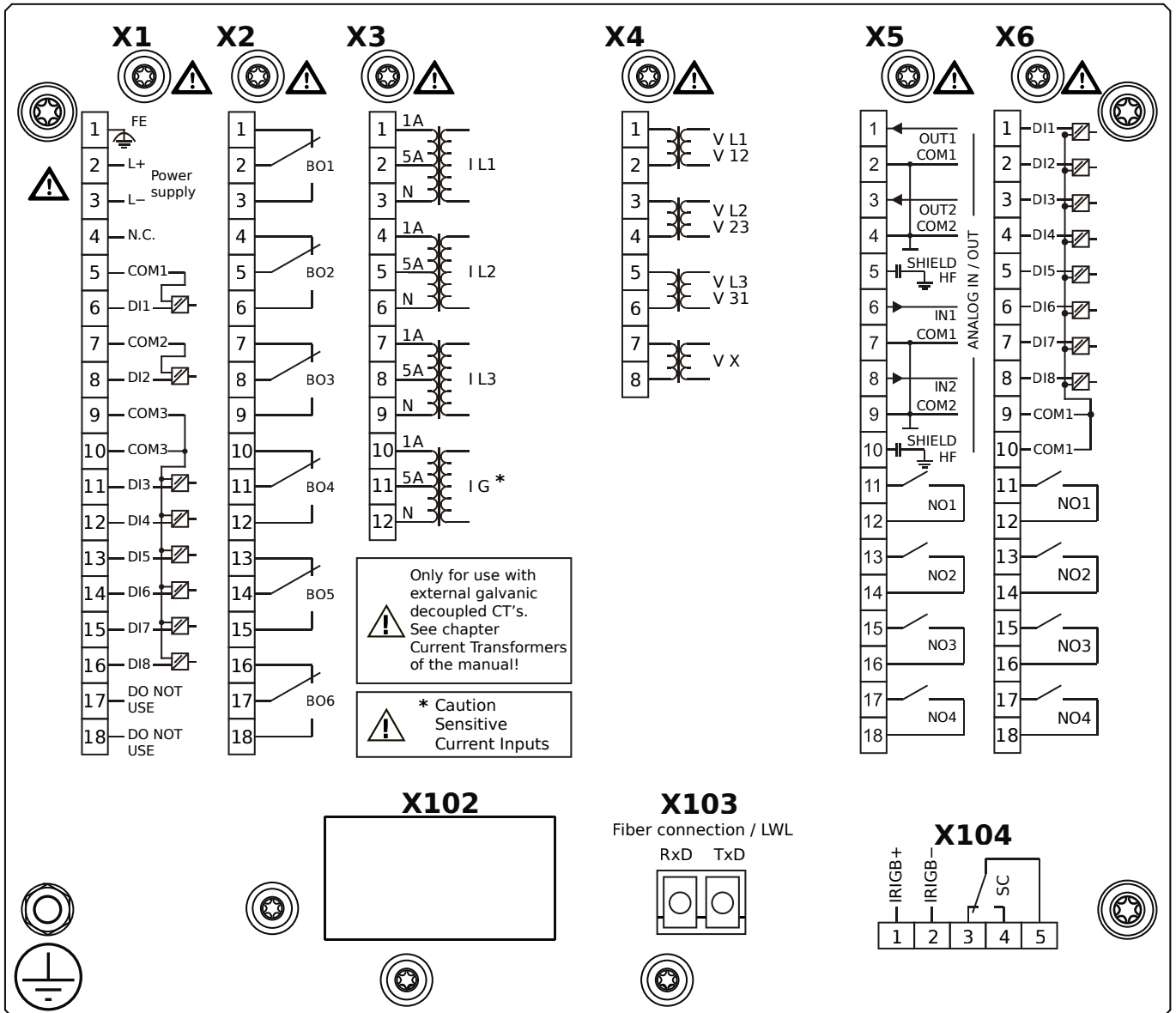

Housing B2, small display, 19" rack mounting

+ Conformal Coating (for installations in harsh environment)

- X1** – DI8-X1: Wide-range power supply unit, incl. 2 non-grouped digital inputs and 6 grouped digital inputs
- X2** – OR6: Assembly Group with 6 Output Relays (Changeover / Form C)
- X3** – TIs: Standard phase current measuring card and sensitive ground current measuring
- X4** – TU: Card with 4 voltage transformer measuring inputs (0 ... 800 VAC, under UL: 0 ... 600 VAC)
- X5** – AnIO2-OR4: Assembly Group with 2 Analog Inputs, 2 Analog Outputs and 4 Output Relays
- X6** – DI8-OR4: Assembly Group with 8 Digital Inputs and 4 Output Relays (NO / Form A)
- X103** – Modbus TCP / DNP3.0 TCP/UDP, Fiber optics interface, LC Connector
- X104** – IRIG-B00X, incl. System Contact (Supervision Contact)

MRA4-2F1BTA

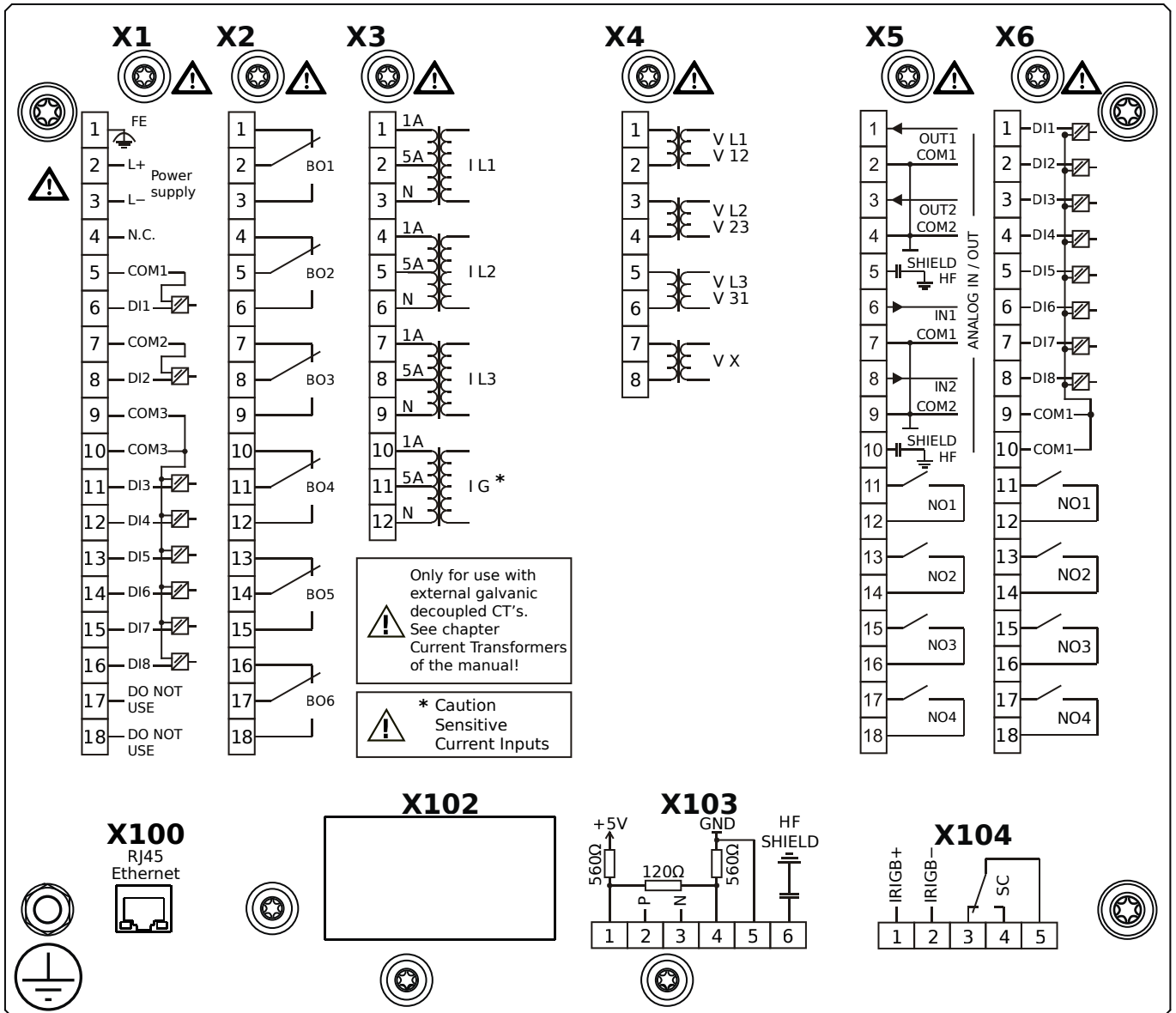

Housing B2, small display, 19" rack mounting

- X1** – DI8-X1: Wide-range power supply unit, incl. 2 non-grouped digital inputs and 6 grouped digital inputs
- X2** – OR6: Assembly Group with 6 Output Relays (Changeover / Form C)
- X3** – TIs: Standard phase current measuring card and sensitive ground current measuring
- X4** – TU: Card with 4 voltage transformer measuring inputs (0 ... 800 VAC, under UL: 0 ... 600 VAC)
- X5** – AnIO2-OR4: Assembly Group with 2 Analog Inputs, 2 Analog Outputs and 4 Output Relays
- X6** – DI8-OR4: Assembly Group with 8 Digital Inputs and 4 Output Relays (NO / Form A)
- X100** – IEC 61850 / Modbus TCP / DNP3.0 TCP/UDP, Ethernet interface, 100 Mbit/s, RJ45 (BASE100-FX)
- X103** – IEC 60870-5-103 / Modbus RTU / DNP3.0 RTU, RS485, Terminals
- X104** – IRIG-B00X, incl. System Contact (Supervision Contact)

MRA4-2F1BTB

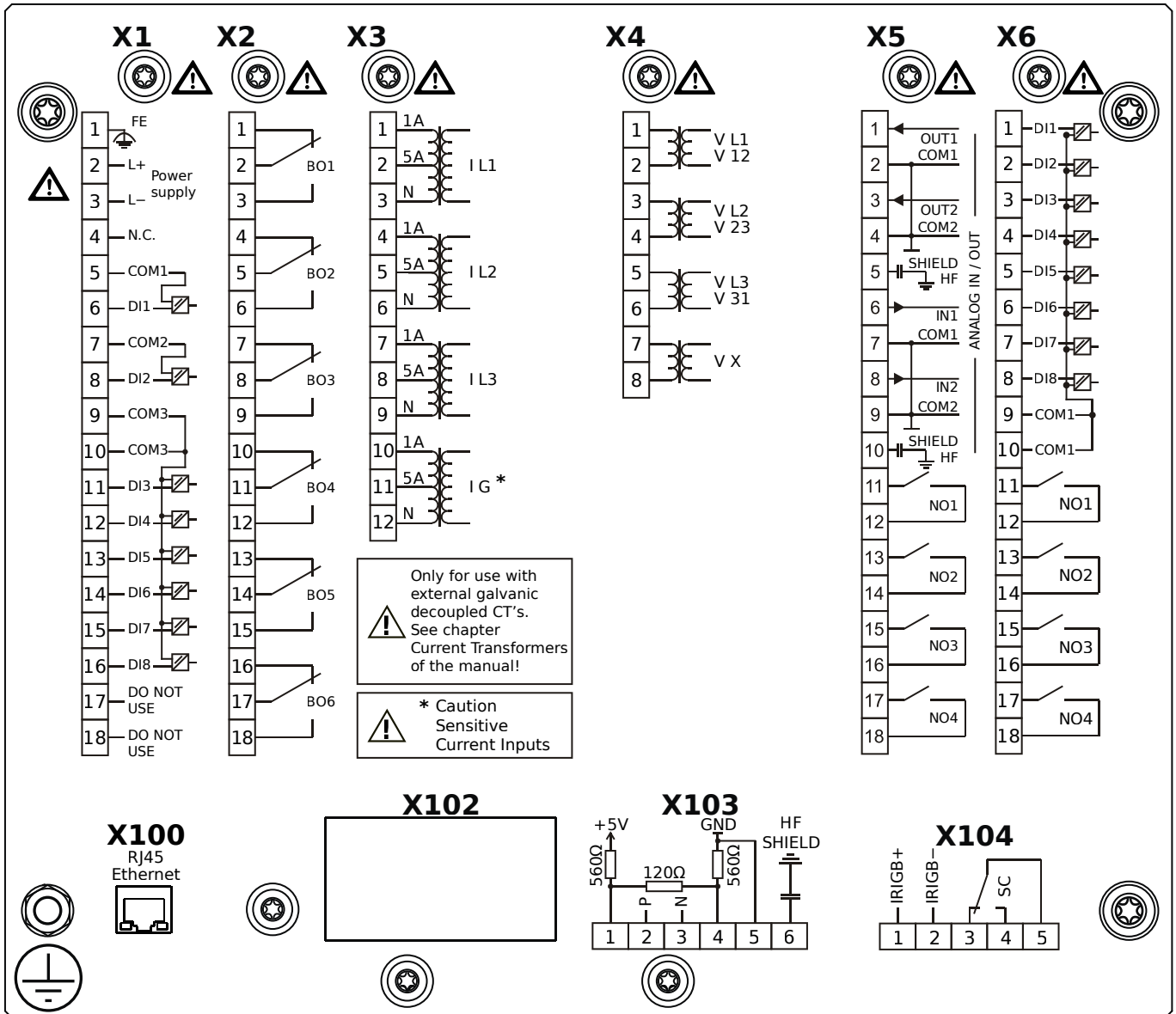

Housing B2, small display, 19" rack mounting

+ Conformal Coating (for installations in harsh environment)

- X1** – DI8-X1: Wide-range power supply unit, incl. 2 non-grouped digital inputs and 6 grouped digital inputs
- X2** – OR6: Assembly Group with 6 Output Relays (Changeover / Form C)
- X3** – TIs: Standard phase current measuring card and sensitive ground current measuring
- X4** – TU: Card with 4 voltage transformer measuring inputs (0 ... 800 VAC, under UL: 0 ... 600 VAC)
- X5** – AnIO2-OR4: Assembly Group with 2 Analog Inputs, 2 Analog Outputs and 4 Output Relays
- X6** – DI8-OR4: Assembly Group with 8 Digital Inputs and 4 Output Relays (NO / Form A)
- X100** – IEC 61850 / Modbus TCP / DNP3.0 TCP/UDP, Ethernet interface, 100 Mbit/s, RJ45 (BASE100-FX)
- X103** – IEC 60870-5-103 / Modbus RTU / DNP3.0 RTU, RS485, Terminals
- X104** – IRIG-B00X, incl. System Contact (Supervision Contact)

Appendix – Legend

In this legend designations of various device types are listed, e.g. transformer protection, motor protection, generator protection, etc. Therefore it can occur that not every designation actually appears on the wiring diagram of your device.

PE	– Connection of protective earth (see chapter Grounding in the Technical Manual).
FE	– Connection of functional earth (see chapter Grounding in the Technical Manual).
Power Supply	– Connection for auxiliary power supply.
IL1	– Phase current input L1 (in some countries designated as IA).
IL2	– Phase current input L2 (in some countries designated as IB).
IL3	– Phase current input L3 (in some countries designated as IC).
ILx C–D	– WIC1 Test windings.
ILx S1–S2	– WIC1 phase current inputs.
IL1 W1 ... IL3 W1	– Phase current input L1...L3, winding side 1.
IL1 W2 ... IL3 W2	– Phase current input L1...L3, winding side 2.
IG	– Ground (earth) current input.
IG W1, IG W2	– Ground (earth) current input, winding side 1 / 2.
VL1	– Phase-to-neutral voltage L1 (in some countries designated as VA).
VL2	– Phase-to-neutral voltage L2 (in some countries designated as VB).
VL3	– Phase-to-neutral voltage L3 (in some countries designated as VC).
VL12	– Phase-to-phase voltage V12 (in some countries designated as VAB).
VL23	– Phase-to-phase voltage V23 (in some countries designated as VBC).
VL31	– Phase-to-phase voltage V31 (in some countries designated as VCA).
VX	– 4th voltage measuring input for measuring residual voltage or synchro-check.
BO	– Binary output relay.
NO / NC	– Contact output, normally open (Form A) / closed (Form B).
DI	– Digital input.
COM	– Common connection of digital inputs.
Out+, AnOut	– Analog output + (0/4...20 mA or 0...10 V).
In–, AnIn	– Analog input + (0/4...20 mA or 0...10 V).
n.c.	– Not connected.
DO NOT USE	– Do not use. (Caution: Non-usable internal wiring may exist.)
SC	– Self-supervision contact.
HF SHIELD	– Connection cable shield.
Fiber Optics / LWL	– Fiber optic connection.

High **PROTEC**

MRA4

WIRING DIAGRAMS

