

			Datum	31.10.2023	SEG EPLAN MACRO	
			Bearb.	dennis.voelkel		
			Gepr		MCDLV4	
Änderung	Datum	Name	Urspr		Ersatz von	Ersetzt durch



MCDLV4-2A0A0AA

SEG_AB20231076

Blatt 1
Seite 1 / 11

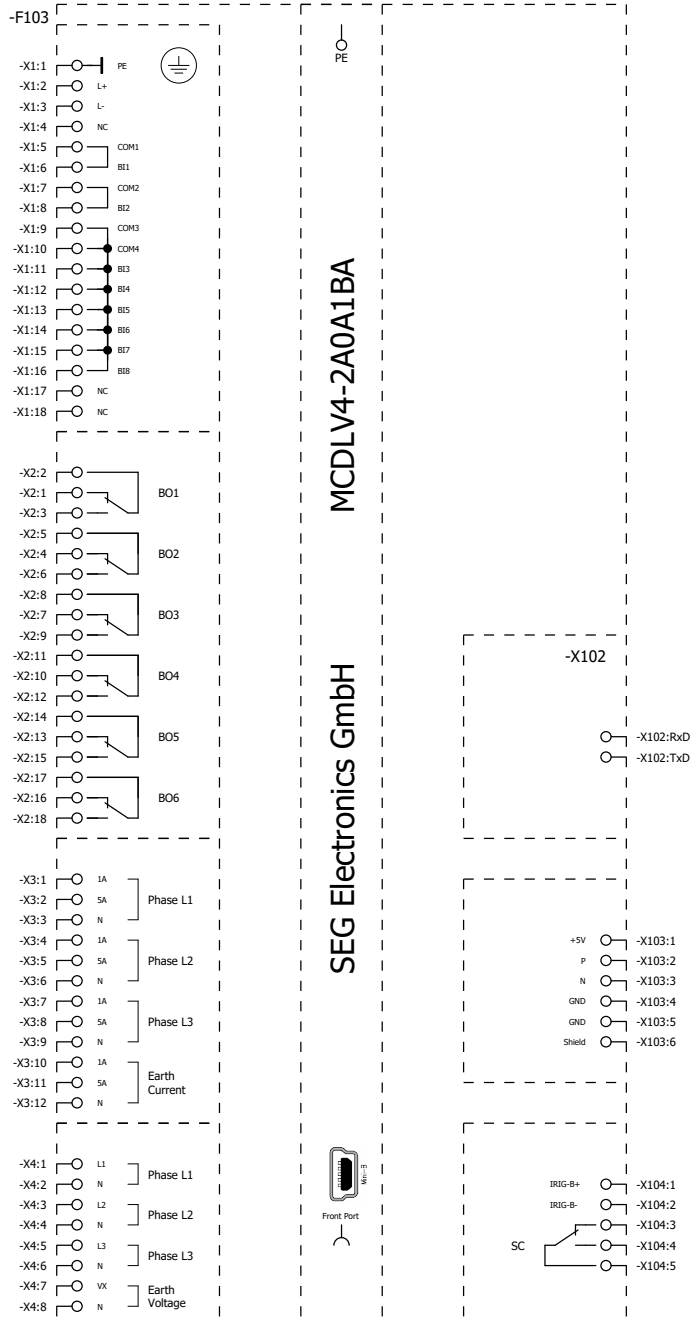

SEG Electronics GmbH MCDLV4-2A0A1BA

			Datum	20.10.2023	SEG EPLAN MACRO	
			Bearb.	dennis.voelkel		
			Gepr		MCDLV4	
Änderung	Datum	Name	Urspr	Ersatz von	Ersetzt durch	



MCDLV4-2A0A0BA

			=	
			+	
		SEG_AB20231076	Blatt	2
			Seite	2 / 11

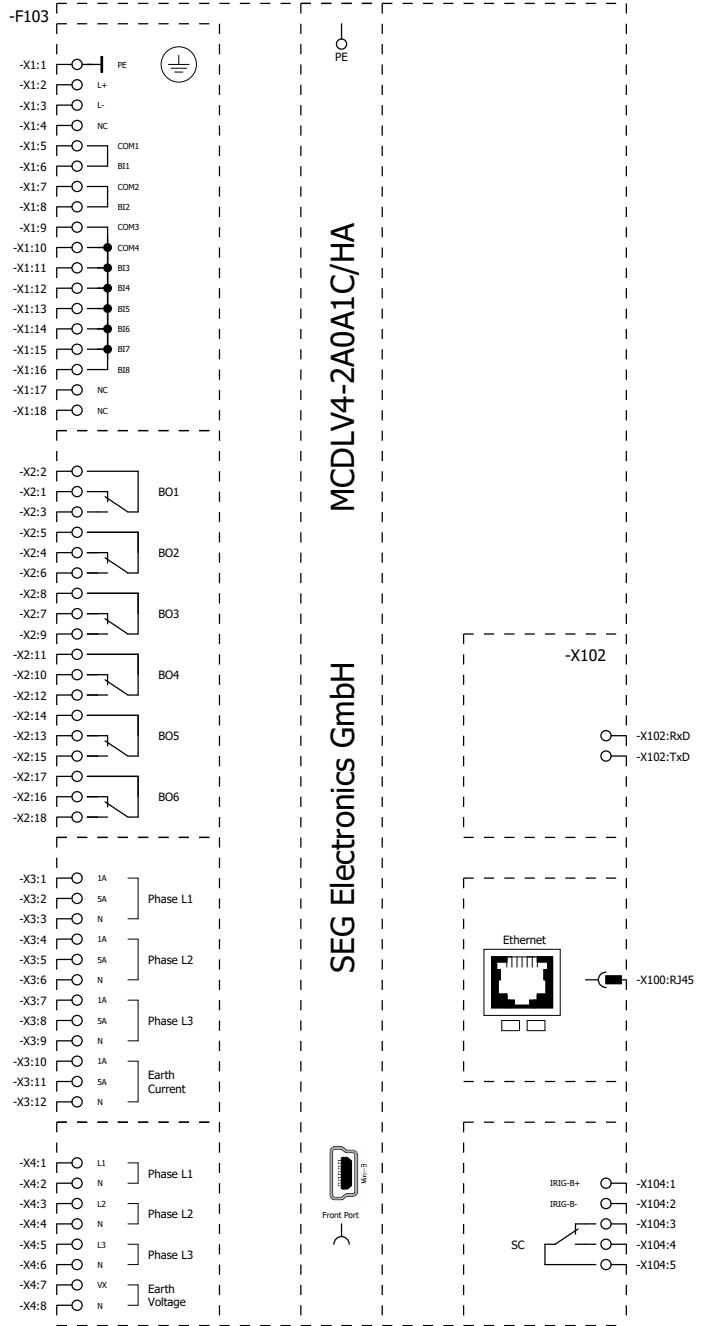

			Datum	20.10.2023	SEG EPLAN MACRO	
			Bearb.	dennis.voelkel		
			Gepr		MCDLV4	
Änderung	Datum	Name	Urspr	Ersatz von	Ersetzt durch	



MCDLV4-2A0A0C_HA

SEG_AB20231076

Blatt 3
Seite 3 / 11

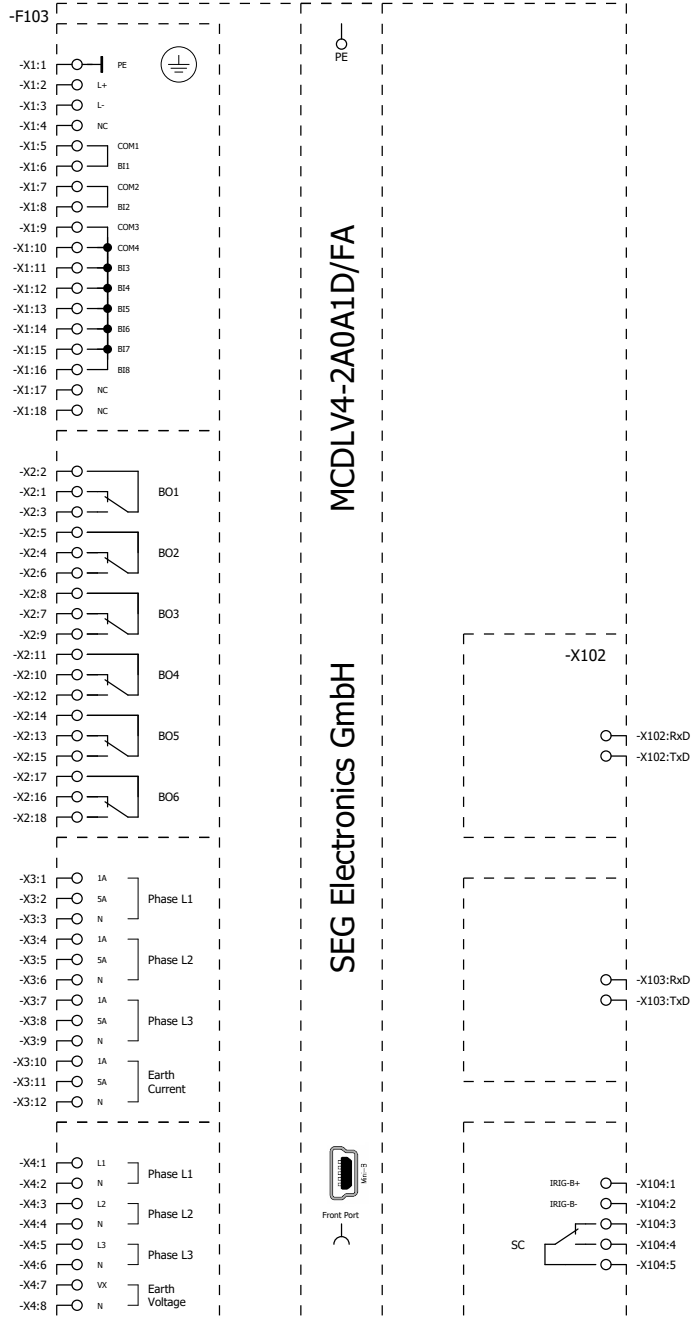

			Datum	20.10.2023	SEG EPLAN MACRO	
			Bearb.	dennis.voelkel		
			Gepr		MCDLV4	
Änderung	Datum	Name	Urspr	Ersatz von	Ersetzt durch	



MCDLV4-2A0A0D_FA

SEG_AB20231076

Blatt 4
Seite 4 / 11

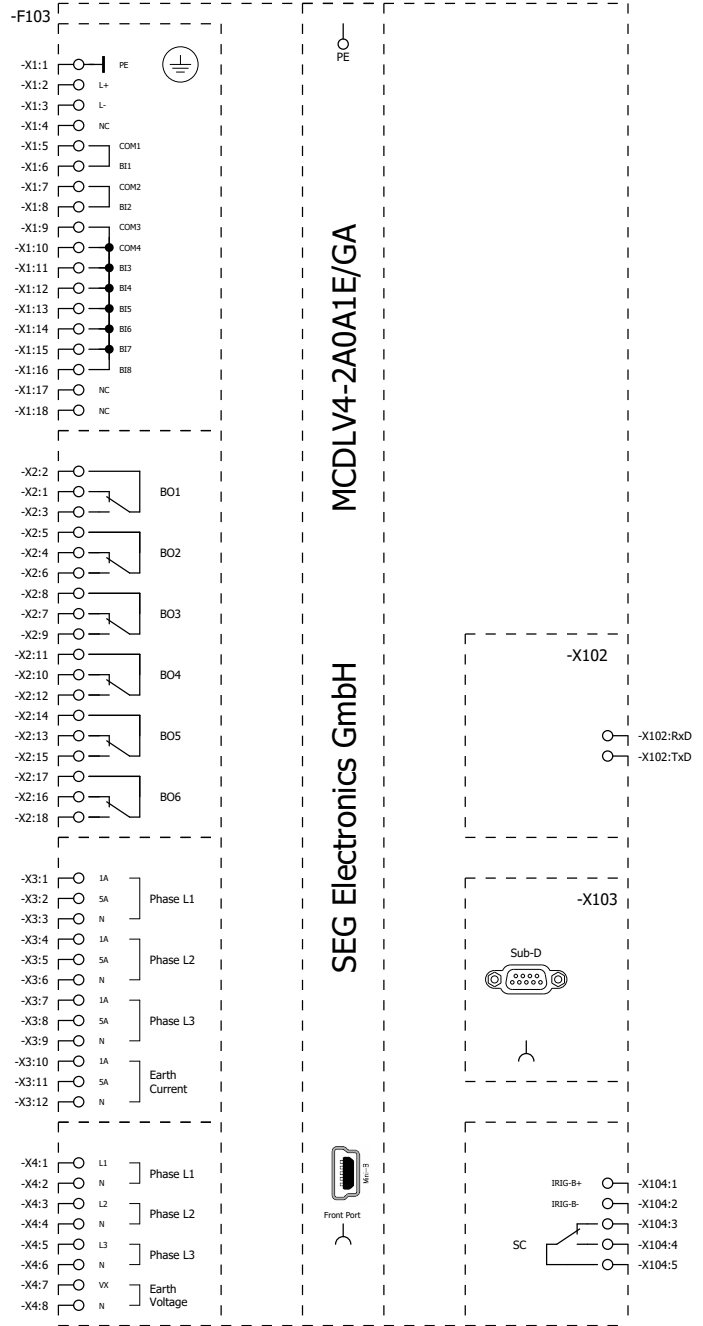

			Datum	20.10.2023	SEG EPLAN MACRO			MCDLV4-2A0A0E_GA		=
			Bearb.	dennis.voelkel	MCDLV4					+
			Gepr							
Änderung	Datum	Name	Urspr		Ersatz von	Ersetzt durch				Blatt 5
									SEG_AB20231076	Seite 5 / 11

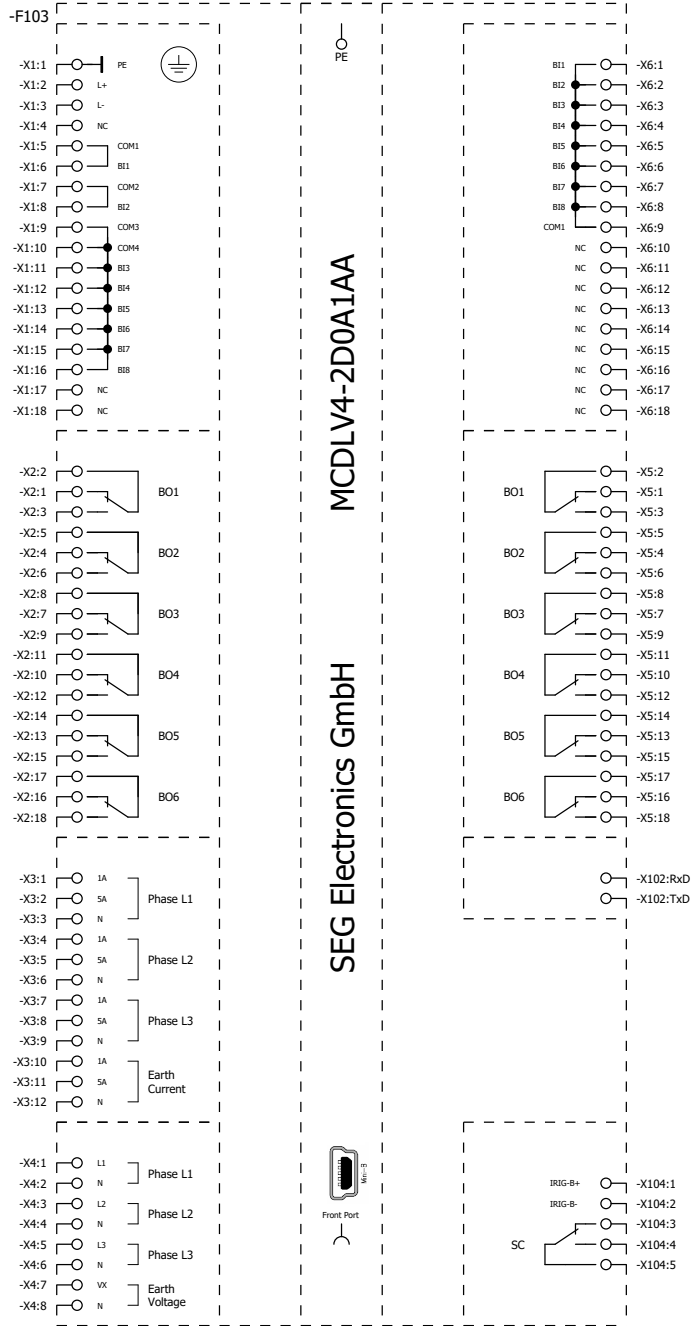

Datum	20.10.2023	SEG EPLAN MACRO	
Bearb.	dennis.voelkel	MCDLV4	
Gepr		Ersatz von	Ersetzt durch
Änderung	Datum	Name	Urspr



MCDLV4-2D0A1AA

SEG_AB20231076

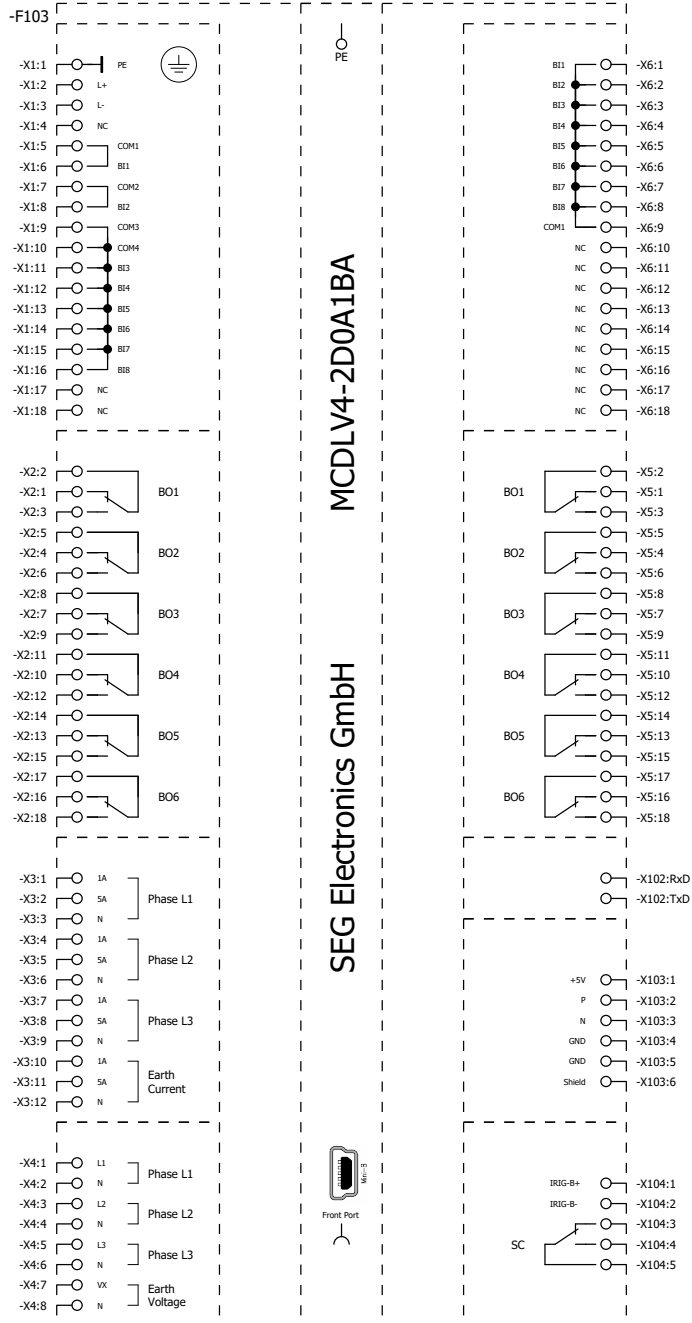

Datum	20.10.2023	SEG EPLAN MACRO
Bearb.	dennis.voelkel	
Gepr		MCDLV4
Änderung	Datum	Name
Urspr	Ersatz von	Ersetzt durch



MCDLV4-2D0A1BA

SEG_AB20231076

Blatt 7
Seite 7 / 11

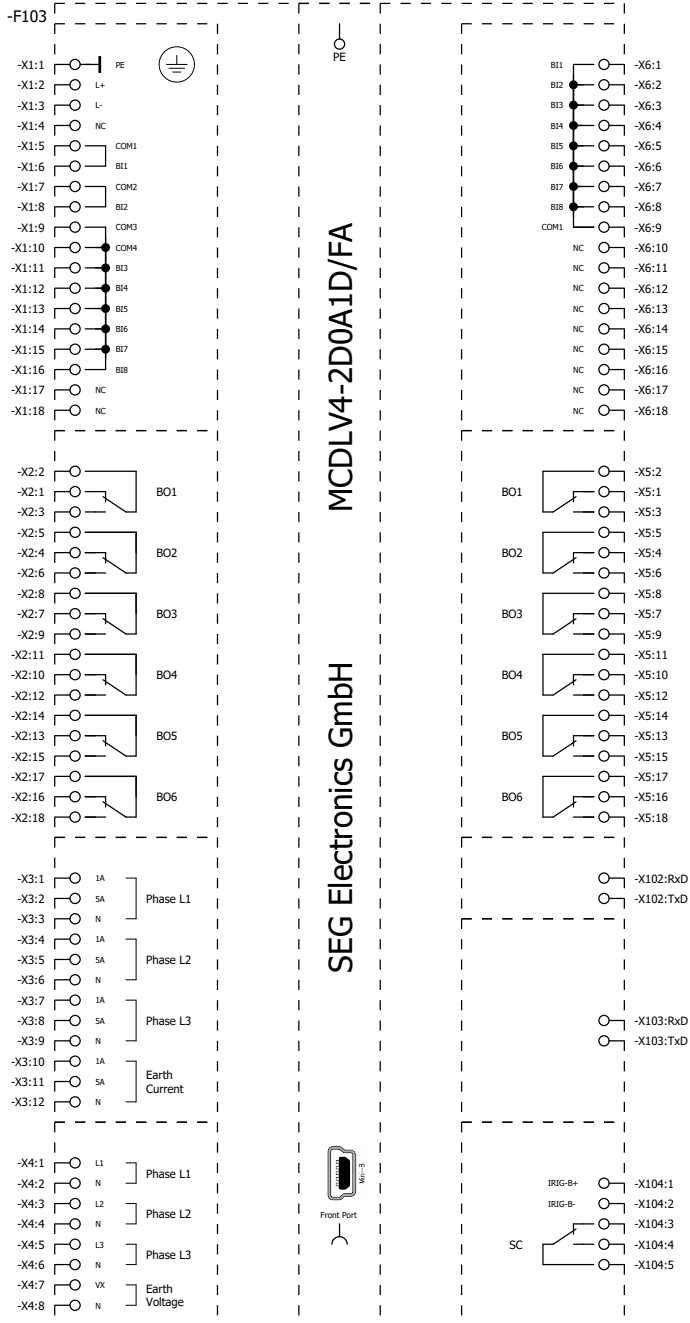

			Datum	20.10.2023	SEG EPLAN MACRO					
			Bearb.	dennis.voelkel	MCDLV4					
			Gepr							
Änderung	Datum	Name	Urspr	Ersatz von	Ersetzt durch					



MCDLV4-2D0A1D_FA

SEG_AB20231076

Blatt 10
Seite 9 / 11

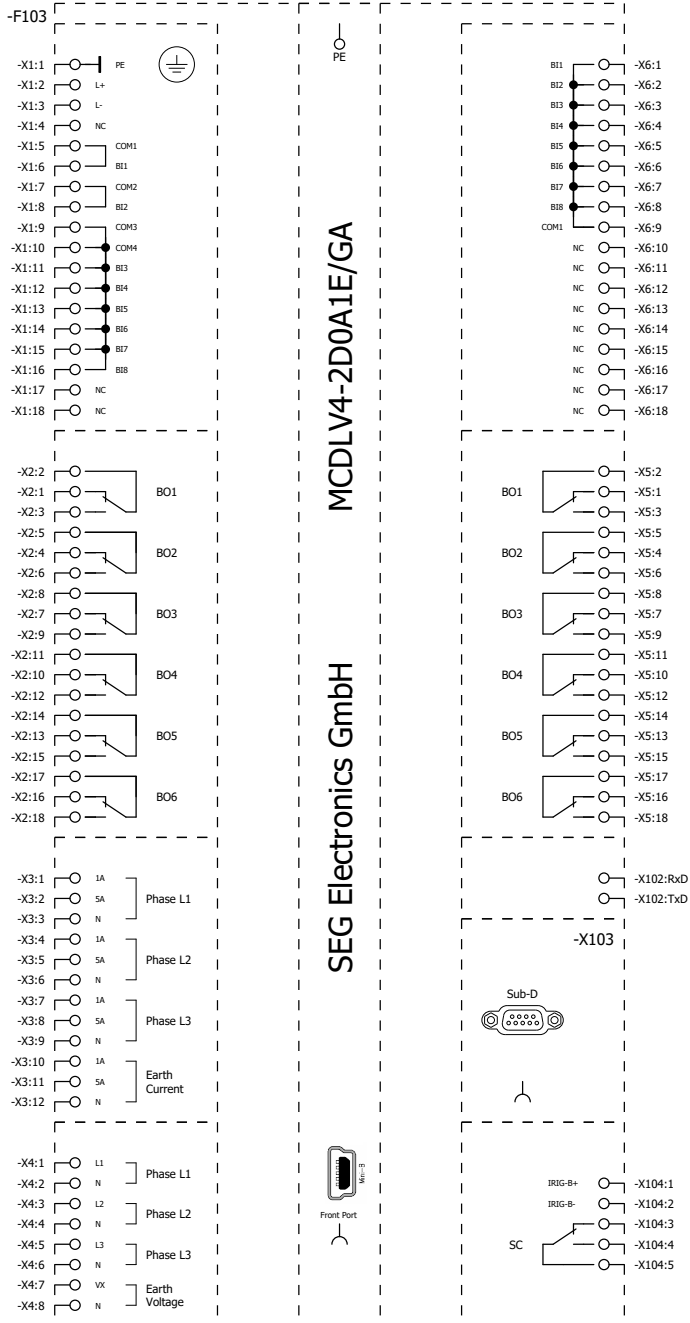

Datum	20.10.2023	SEG EPLAN MACRO
Bearb.	dennis.voelkel	
Gepr		MCDLV4
Änderung	Datum	Name
Urspr	Ersatz von	Ersetzt durch



MCDLV4-2D0A1E_GA

SEG_AB20231076

Blatt 11
Seite 10 / 11

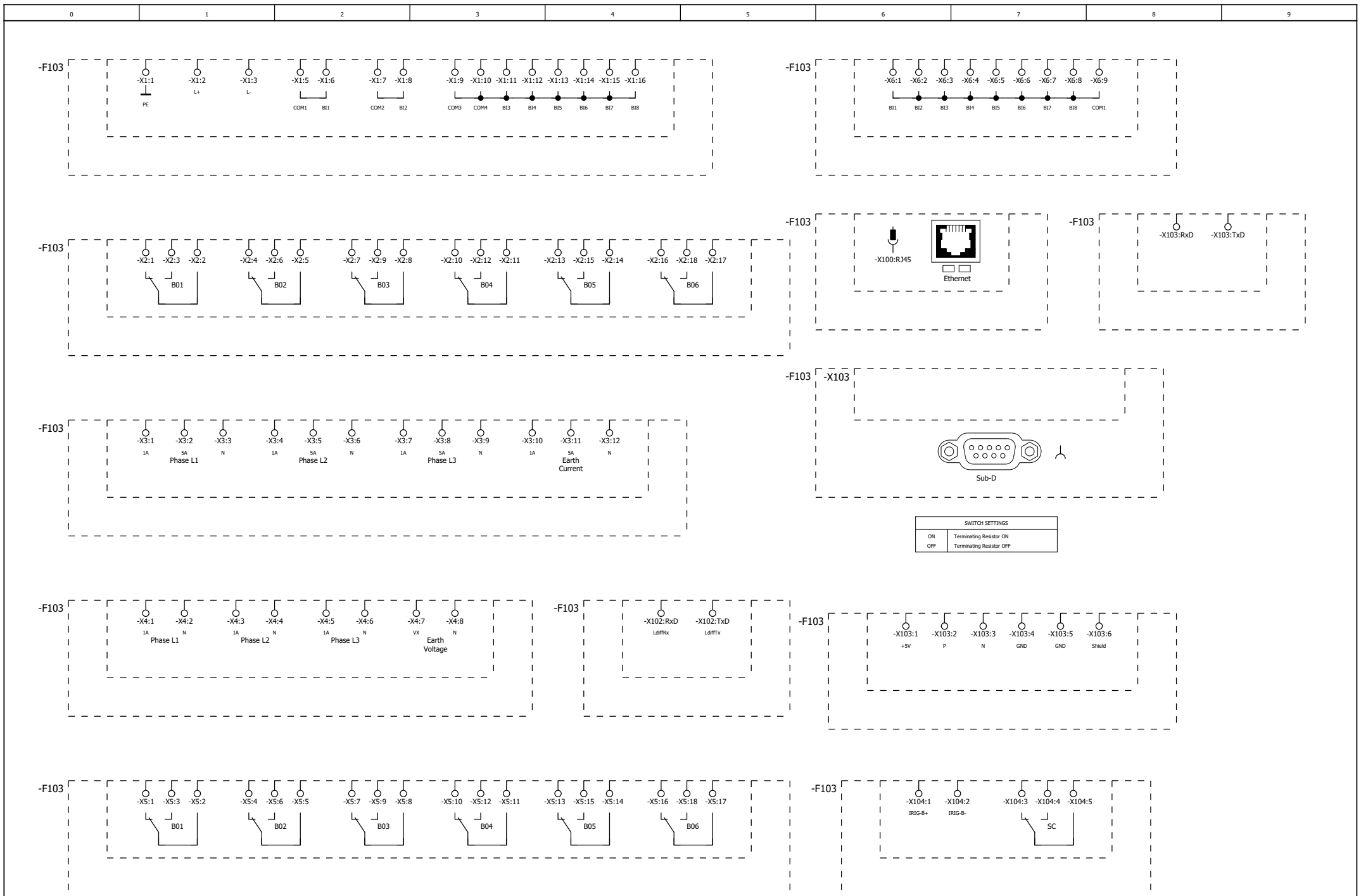

+ / 11

			Datum	31.10.2023	SEG EPLAN MACRO		Peripherie	=	+ PER	Blatt 12
			Bearb.	dennis.voelkel	MCDLV4					
			Gepr							
Änderung	Datum	Name	Urspr	Ersatz von	Ersetzt durch				SEG_AB20231076	Seite 11 / 11