

# HighPROTEC | PROTECTION TECHNOLOGY MADE SIMPLE

## MCA4 | FEEDER PROTECTION AND INTER- CONNECTION OF DECENTRALIZED ENERGY RESOURCES

### NEW FEATURES - Release 3.6

- VDE-AR-N 4110; VDE-AR-N 4120
- Wattmetric Ground Fault Protection
- IEC 60870-5-104
- SCADApter for Retrofit
- Usability improvements
- IT Security
- Improved Frequency and ROCOF precision\*

### APPLICATION

The MCA4 is a precise and reliable protection, control and monitoring relay for feeder, grid and generator applications. The latest generation series from Woodward (formerly SEG), the MCA4 incorporates all the ANSI and IEC concepts to comply with ever changing grid interconnection requirements. Flexibility in hardware, software, application, user interface and communications makes the MCA4 adaptable to requirements today and in the future. The protection functions of the MCA4 have been adapted to comply with the requirements of the VDE-AR-N-4110/4120:2018. The parameterizing and analyzing software Smart view is usable for each HighPROTEC device and free of charge.



### COMPREHENSIVE PROTECTION PACKAGE <sup>(1)</sup>

- Six elements phase overcurrent protection directional and non-directional (ANSI/IEC/51C/51V)
- Frequency measurement and ROCOF (df/dt) measurement is now user-adjustable. Furthermore, measurement precision has been improved.  
\*5mHz from 45-55 Hz
- Four elements earth fault protection <sup>(2)</sup> non-directional or directional (multi-polarising)
- Wattmetric Ground Fault Protection
- Two elements unbalanced load protection
- Voltage protection <sup>(2)</sup> six elements selectable: V<, V>, V<(t)
- Six elements unbalanced voltage supervision
- Flexible Fourth Voltage measuring input <sup>(2)</sup> 2 elements VE> or VX (for synch-check)
- Synchro-check options  
Generator-to-System or System-to-System
- Each of the six elements frequency protection can be used as:  
f<, f>, ROCOF, vector surge...
- Six elements power protection each can be used as:  
P>, P<, Pr, Q>, Q<, Qr, S>, S<
- Two elements power factor (PF)

### POWER QUALITY

- THD protection

### DEMAND MANAGEMENT/ PEAK VALUES

- Peak values of current and power, average current and energy demand

### INTERCONNECTION PACKAGE

The comprehensive interconnection package is summarized within one menu:

- Non-discriminating active power direction depending load shedding
- HVRT (High Voltage Ride Through)
- FRT (LVRT): Settable FRT-Profiles, optional AR coordinated
- QV-Protection: Undervoltage-Reactive Power protection
- Automatic Reconnection
- Frequency protection:  
Six elements configurable as  
f<, f>, df/dt (ROCOF), Vector Surge
- CB-Intertripping
- Synch Check (Generator to mains, mains-to-mains), options e.g. to switch onto dead bus

### RECORDERS

- Disturbance recorder: 120 s non volatile
- Fault recorder: 20 faults
- Event recorder: 300 events
- Trend recorder: 4000 non volatile entries

### PC TOOLS

- Setting and analyzing software Smart view for free
- Including page editor to design own pages
- SCADApter reassign Modbus and IEC 60870-5-104 registers for Retrofit projects

### CONTROL

- of up to six breakers (or isolators/grounding switches)
- Breaker wear

### COMMISSIONING SUPPORT

- USB connection
- Customizable Display (Single-Line, ...)
- Customizable Inserts
- Copy and compare parameter sets
- Configuration files are convertible
- Forcing and disarming of output relays
- Fault simulator: current and voltage
- Graphical display of tripping characteristics
- 8 languages selectable within the relay

### COMMUNICATION OPTIONS

- IEC 61850
- Profibus DP
- Modbus RTU and/or Modbus TCP
- IEC 60870-5-103
- IEC 60870-5-104
- DNP 3.0 (RTU, TCP, UDP)
- SCADApter

### IT SECURITY

- Menu for the activation of BDEW-Whitepaper-compliant security settings (e.g. hardening of interfaces)
- Security Logger
- Centralized Security Logs (Syslog)
- Encrypted Smart view - Device Connection
- Device specific certificates (No man in the middle attacks)

### LOGIC

- Up to 80 logic equations for protection, control and monitoring

### TIME SYNCHRONISATION

- SNTP, IRIG-B00X, Modbus, DNP 3.0, IEC 60870-5-103/-104

<sup>(1)</sup> DFT, True RMS or I2 based

<sup>(2)</sup> DFT or True RMS based

## FUNCTIONAL OVERVIEW

	Elements	ANSI
<b>Protective Functions</b>		
I, time overcurrent and short circuit protection, all elements can be configured for directional or non-directional supervision. Multiple reset options (instantaneous, definite time, reset characteristics according to IEC and ANSI).	6	50P, 51P, 67P
Voltage controlled overcurrent protection by means of adaptive parameters		51C
Voltage dependent overcurrent protection		51V
Negative phase sequence overcurrent protection		51Q
I2>, unbalanced load protection with evaluation of the negative phase sequence currents	2	46
IB, overload protection with thermal replica and separate pick-up values for alarm and trip functions	1	49
IH2/In, inrush detection with evaluation of the 2nd harmonic	1	Inrush
IG, earth overcurrent and short circuit protection, all elements can be configured for directional (multi-polarising) or non-directional supervision. Tremendous reset options (instantaneous, definite time, reset characteristics according to IEC and ANSI).	4	50N/G, 51N/G, 67N/G
V<, V>, V(t)<, under- and overvoltage protection, time dependent undervoltage protection	6	27, 59
Voltage asymmetry supervision (V012)		
V1, under and overvoltage in positive phase sequence system	6	47
V2, overvoltage in negative phase sequence system		
Each of the six frequency protection elements can be used as: f< fs, df, dt, ROCOF, DF/DT, vector surge, ...	6	81U/O, 81R, 78
VX, residual voltage protection or bus bar voltage for Synch Check	2	25 or 59N/G
AR, automatic reclosing	1	79
ExP, External alarm and trip functions	4	
PQS, Power protection	6	32, 37
PF, Power factor	2	55
FRT (optional coordination with AR-feature)	27 (t)	27 (t, AR)
HVRT (OVRT) High Voltage Ride Through	1	59
Q(V) Protection (undervolt. dep. directional reactive power protection with reclosing disengaging)		
UFLS (non-discriminating active power direction depending load shedding)		
10-Minutes-Mean-Square-Sliding Supervision: adjustable according to VDE-AR 4105		
Synch Check		25
<b>Control and Logic</b>		
Control: Position indication, supervision time management and interlockings for up to 6 breakers		
Logic: Up to 80 logic equations, each with 4 inputs, selectable logical gates, timers and memory function		
<b>Supervision Functions</b>		
CBF, circuit breaker failure protection	1	50BF
TCS, trip circuit supervision	1	74TC
LOP, loss of potential	1	60FL
FF, fuse failure protection via digital input	1	60FL
CTS, current transformer supervision	1	60L
CLPU, cold load pickup	1	
SOTF, switch onto fault	1	
Demand management and peak value supervision (current and power)		
THD supervision		
Breaker wear with programmable wear curves		
Recorders: Disturbance recorder, fault recorder, event recorder, trend recorder		

## FUNCTIONAL OVERVIEW IN ANSI FORM

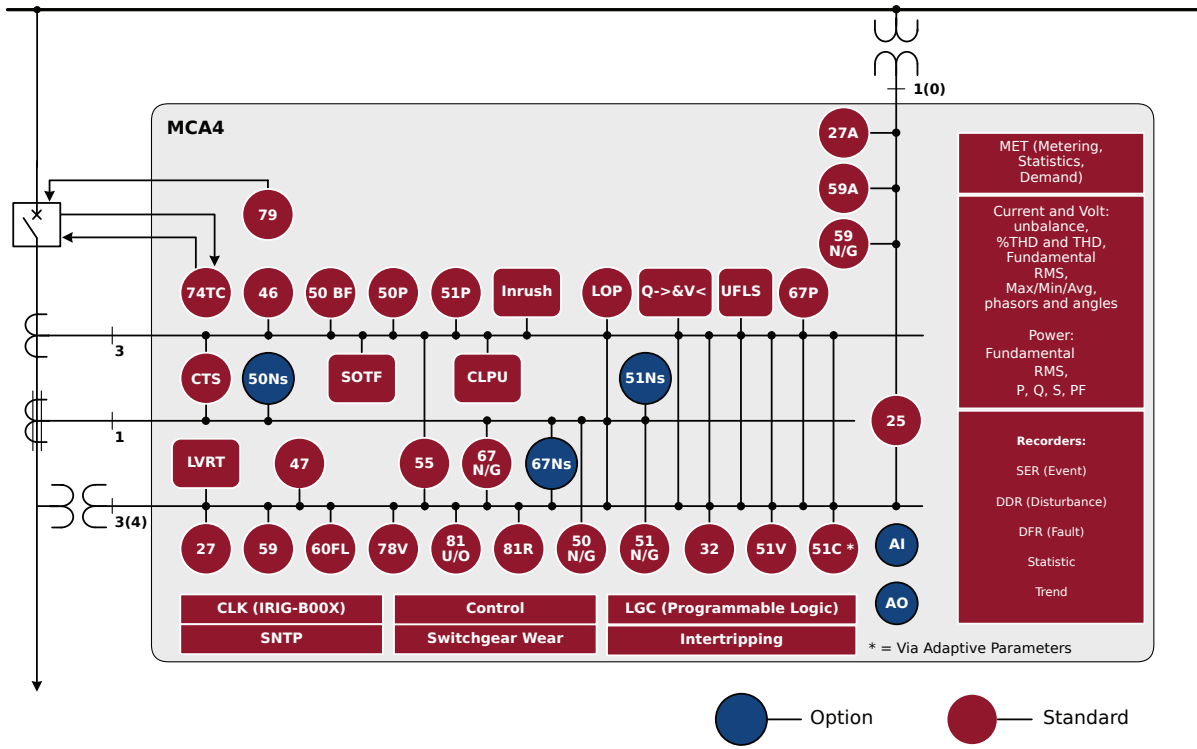

## APPROVALS



certified regarding UL508 (Industrial Controls)



certified regarding CSA-C22.2 No. 14 (Industrial Controls)



certified by EAC (Eurasian Conformity)



Type tested (and certified) regarding IEC60255-1 and regarding IEC61850



certified regarding "BDEW-Richtlinie für Erzeugungsanlagen am Mittelspannungsnetz, Ausgabe Juni 2008" (German grid code standard)



(Declaration of Identity)



Type Approval Certificate from CQC China complies with VDE-AR-N4110 and VDE-AR-N4120

## CONNECTIONS (EXAMPLE)

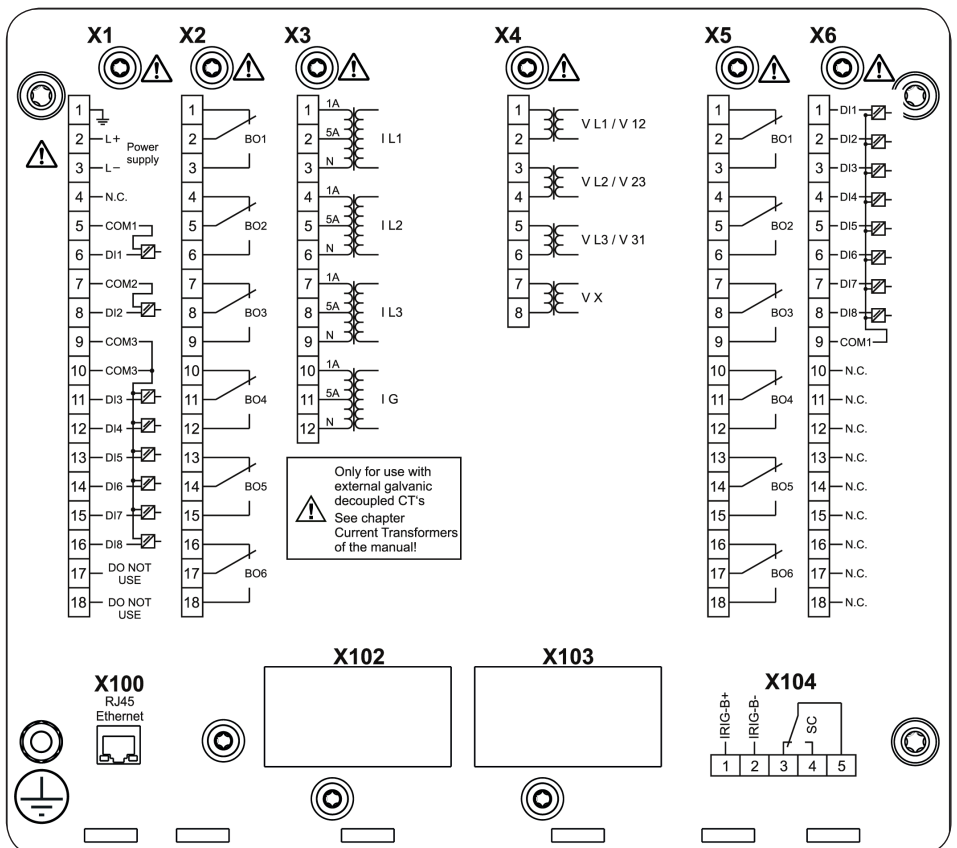

Complies with IEEE 1547-2003 Amended by IEEE 1547a-2014 Complies with ANSI C37.90-2005

Complies with „Engineering Recommendation G59 Issue 3 Amendment 4 - July 2018“

**ORDER FORM MCA4**

Directional Feeder Protection					MCA4	-2				
Version 2 with USB, enhanced communication and user options										
Analog In	Digital	Binary	Housing	Large						
Analog Out	Inputs	output relays		display						
-	8	7	B2	X						A
-	16	13	B2	X						D
-	24	20	B2	X						E
2+2	16	15	B2	X						F
<b>Hardware variant 2</b>										
Phase Current 5 A/1 A, Ground Current 5 A/1 A										0
Phase Current 5 A/1 A, Sensitive Ground Current 5 A/1 A										1
<b>Housing and mounting</b>										
Door mounting										A
Door mounting 19" (flush mounting)										B
<b>Communication protocol</b>										
Without protocol										A
Modbus RTU, IEC 60870-5-103, DNP 3.0 RTU   <i>RS485/terminals</i>										B*
Modbus TCP, DNP 3.0 TCP/UDP, IEC 60870-5-104   <i>Ethernet 100 MB/RJ45</i>										C*
Profibus-DP   <i>optic fiber/ST-connector</i>										D*
Profibus-DP   <i>RS485/D-SUB</i>										E*
Modbus RTU, IEC 60870-5-103, DNP 3.0 RTU   <i>optic fiber/ST-connector</i>										F*
Modbus RTU, IEC 60870-5-103, DNP 3.0 RTU   <i>RS485/D-SUB</i>										G*
IEC 61850, Modbus TCP, DNP 3.0 TCP/UDP, IEC 60870-5-104   <i>Ethernet 100MB/RJ45</i>										H*
IEC 60870-5-103, Modbus RTU, DNP 3.0 RTU   <i>RS485/terminals</i>										I*
Modbus TCP, DNP 3.0 TCP/UDP, IEC 60870-5-104   <i>Ethernet 100 MB/RJ45</i>										
IEC 61850, Modbus TCP, DNP 3.0 TCP/UDP, IEC 60870-5-104   <i>Optical Ethernet 100MB/LC duplex connector</i>										K*
Modbus TCP, DNP 3.0 TCP/UDP, IEC 60870-5-104   <i>Optical Ethernet 100MB/LC duplex connector</i>										L*
IEC 60870-5-103, Modbus RTU, DNP 3.0 RTU   <i>RS485/terminals</i>										
IEC 61850, Modbus TCP, DNP 3.0 TCP/UDP, IEC 60870-5-104   <i>Ethernet 100 MB/RJ45</i>										T*
<b>Harsh Environment Option</b>										
None										A
Conformal Coating										B
<b>Available menu languages (in every device)</b>										
English / German / Spanish / Russian / Polish / Portuguese / French / Romanian										

\* Within every communication option only one communication protocol is usable.

<b>Current inputs</b>	4 (1 A and 5 A) with automatic CT Disconnect
<b>Voltage inputs</b>	4 (0 ... 800 V)
<b>Digital Inputs</b>	Switching thresholds adjustable via software
<b>Power supply</b>	Wide range power supply 24 V <sub>DC</sub> – 270 V <sub>DC</sub> / 48 V <sub>AC</sub> – 230 V <sub>AC</sub> (–20/+10%)
<b>Terminals</b>	All terminals plug type
<b>Type of enclosure</b>	IP54
<b>Dimensions of housing (W x H x D)</b>	19" flush mounting: 212.7 mm x 173 mm x 208 mm 8.374 in. x 6.811 in. x 8.189 in. Door mounting: 212.7 mm x 183 mm x 208 mm 8.374 in. x 7.205 in. x 8.189 in.
<b>Weight (max. components)</b>	approx. 4.2 kg / 9.259 lb

**CONTACT:**

**North & Central America**

Phone: +1 970 962 7272  
+1 208 278 3370  
E-mail: SalesPGD\_NAandCA@woodward.com

**South America**

Phone: +55 19 3708 4760  
E-mail: SalesPGD\_SA@woodward.com

**Europe**

Phone (Kempen): +49 2152 145 331  
Phone (Stuttgart): +49 711 78954 510  
E-mail: SalesPGD\_EMEA@woodward.com

**Middle East & Africa**

Phone: +971 2 678 4424  
E-mail: SalesPGD\_EMEA@woodward.com

**Russia**

Phone: +49 711 78954 515  
E-mail: SalesPGD\_EMEA@woodward.com

**China**

Phone: +86 512 8818 5515  
E-mail: SalesPGD\_CHINA@woodward.com

**India**

Phone: +91 124 4399 500  
E-mail: Sales\_India@woodward.com

**ASEAN & Oceania**

Phone: +49 711 78954 510  
E-mail: SalesPGD\_ASEAN@woodward.com

For more information please contact: