

			Datum	06.10.2023	SEG EPLAN MACRO	
			Bearb.	dennis.voelkel		
			Gepr		MCA4	
Aenderung	Datum	Name	Urspr	Ersatz von	Ersetzt durch	

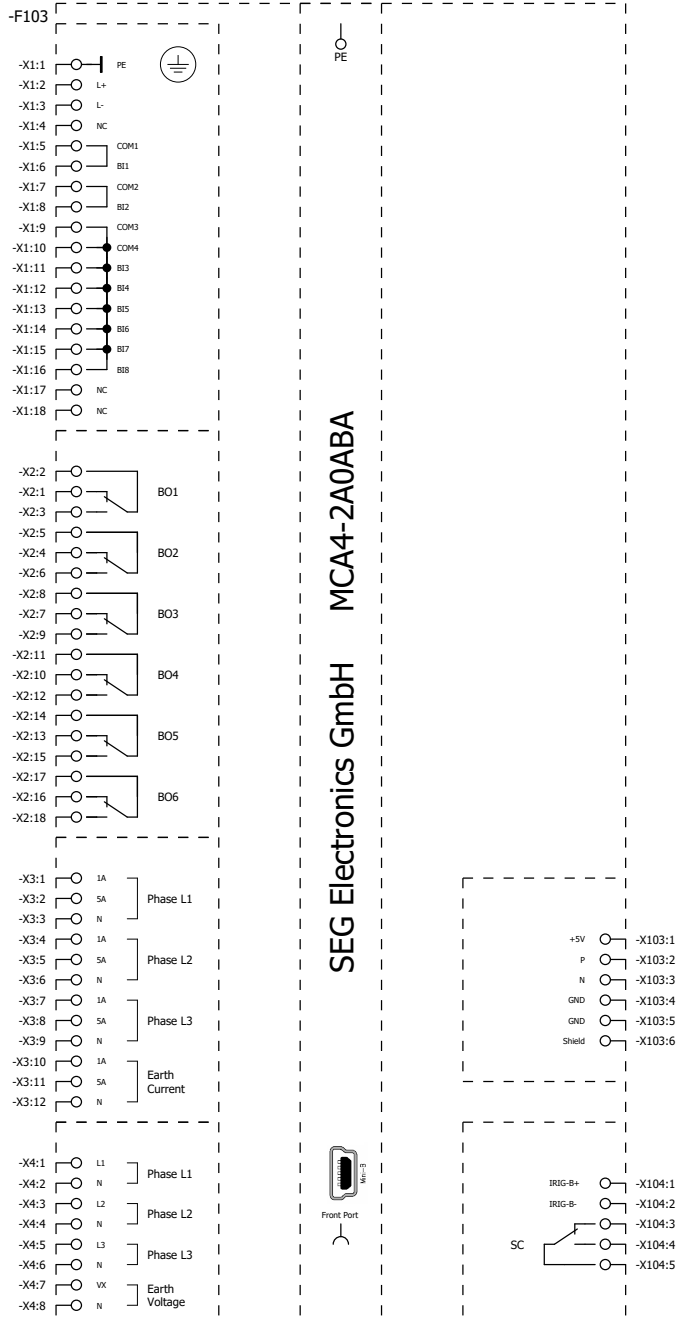

MCA4-2A0AAA

SEG\_AB20231076



SEG Electronics GmbH MCA4-2A0ABA

Datum	06.10.2023	SEG EPLAN MACRO	
Bearb.	dennis.voelkel	MCA4	
Gepr		Ersatz von	Ersetzt durch
Änderung	Datum	Name	Urspr



MCA4-2A0ABA

SEG\_AB20231076

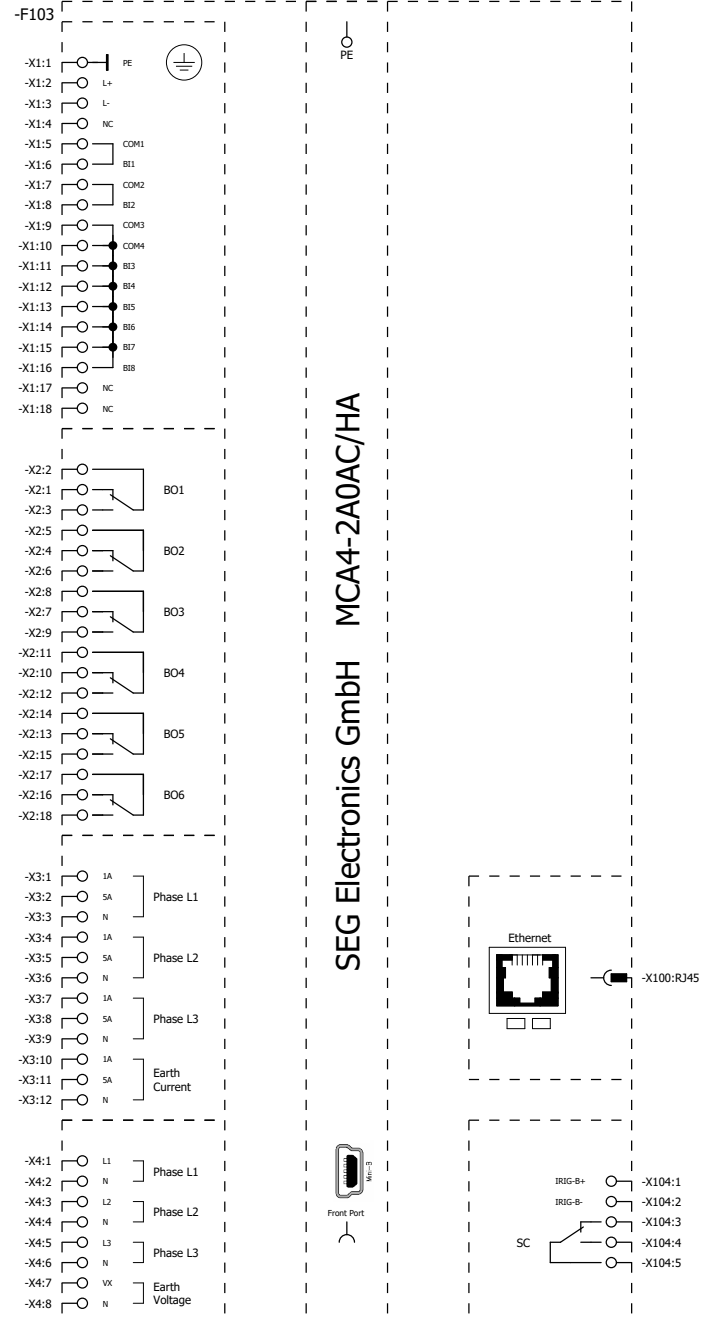

SEG Electronics GmbH MCA4-2A0AC/HA

			Datum	06.10.2023	SEG EPLAN MACRO	
			Bearb.	dennis.voelkel		
			Gepr		MCA4	
Aenderung	Datum	Name	Urspr		Ersatz von	Ersetzt durch



MCA4-2A0AC\_HA

SEG\_AB20231076

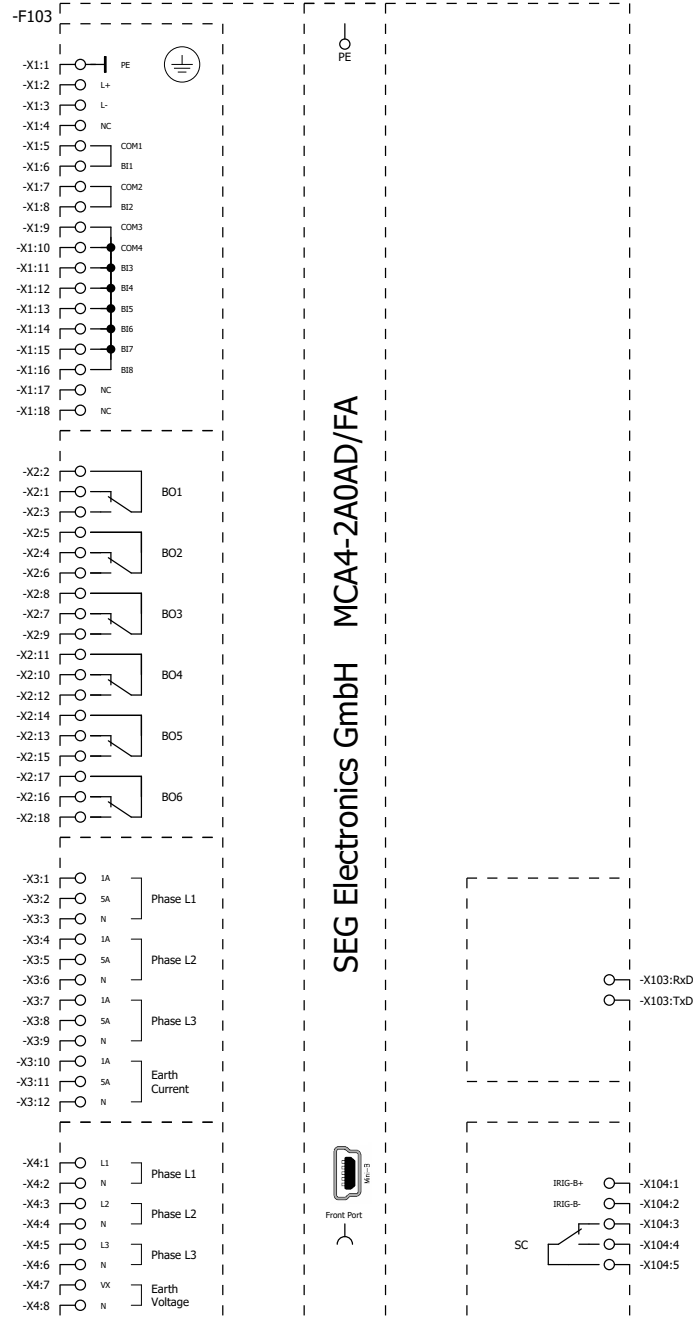

			Datum	06.10.2023	SEG EPLAN MACRO	
			Bearb.	dennis.voelkel		
			Gepr		MCA4	
Aenderung	Datum	Name	Urspr		Ersatz von	Ersetzt durch



MCA4-2A0AD\_FA

			=	
			+	
		SEG_AB20231076	Blatt	4
			Seite	4 / 11

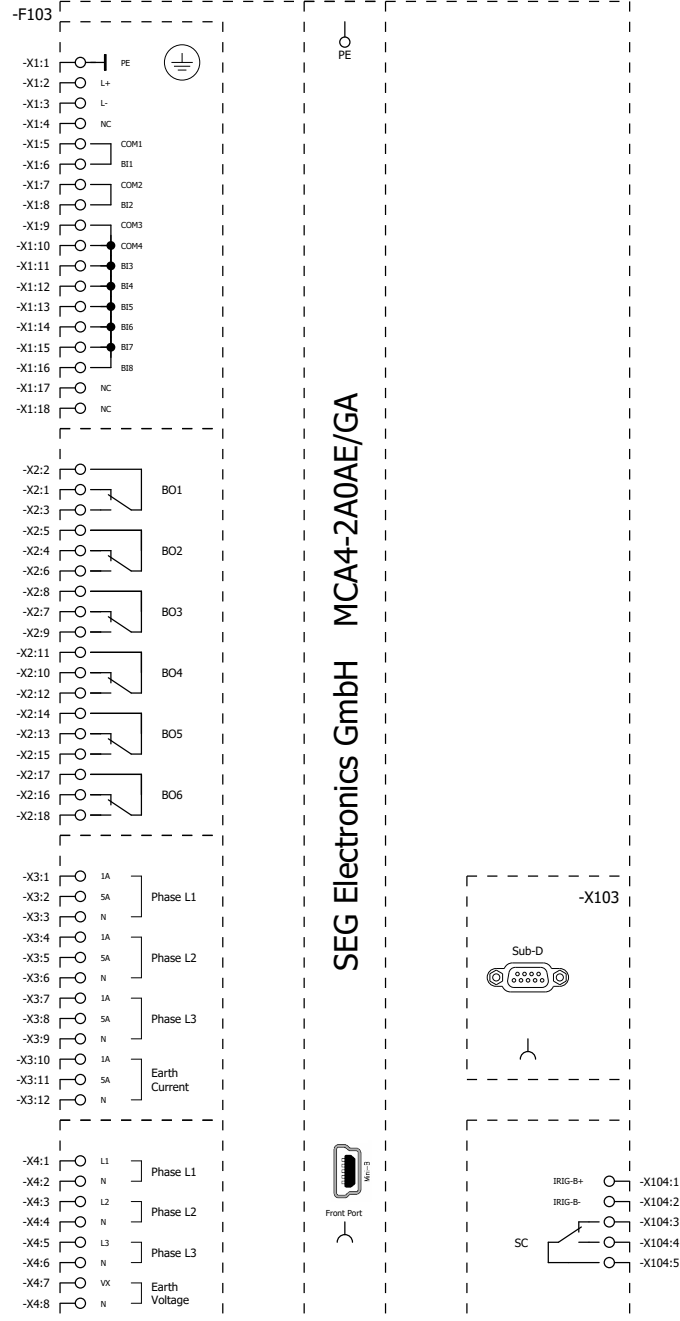

			Datum	06.10.2023	SEG EPLAN MACRO				
			Bearb.	dennis.voelkel					
			Gepr		MCA4				
Aenderung	Datum	Name	Urspr		Ersatz von	Ersetzt durch			
							SEG electronics	MCA4-2A0AE_GA	
								SEG_AB20231076	Blatt 5
									Seite 5 / 11

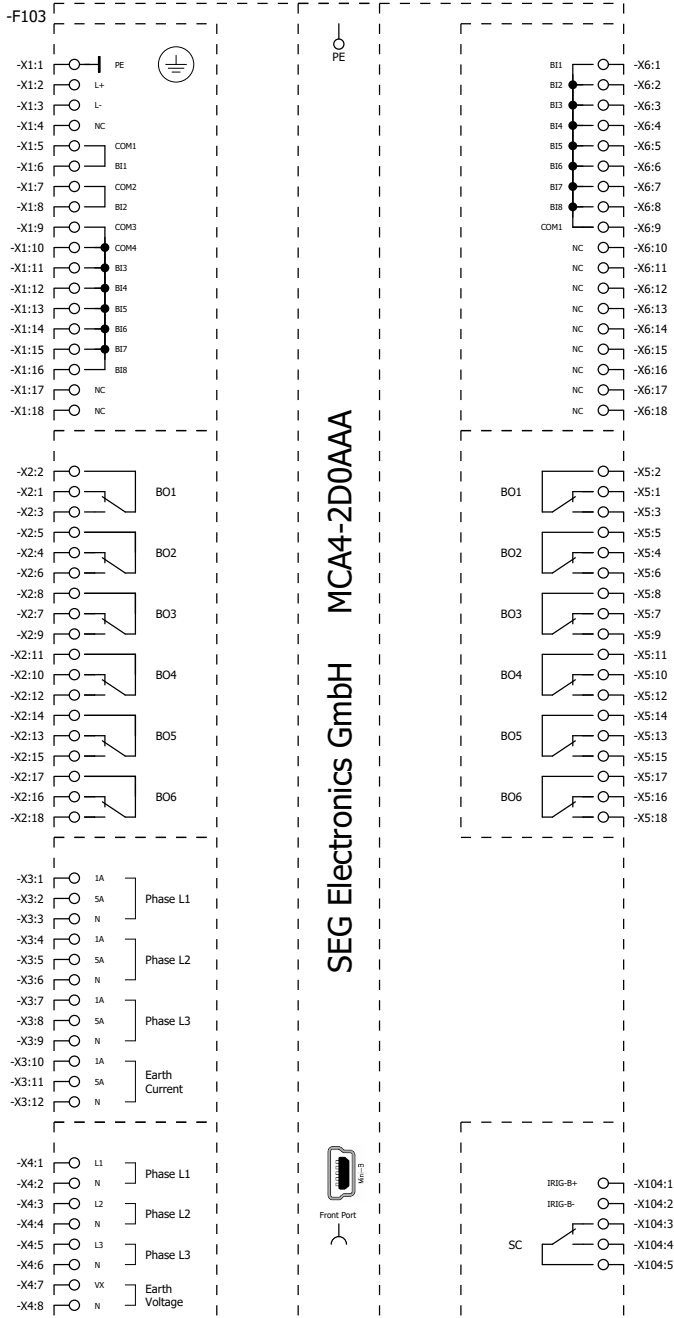

SEG Electronics GmbH MCA4-2D0AAA



			Datum	06.10.2023	SEG EPLAN MACRO		=
			Bearb.	dennis.voelkel			+
			Gepr		MCA4		
Änderung	Datum	Name	Urspr		Ersatz von	Ersetzt durch	
						MCA4-2D0AAA	
						SEG_AB20231076	Blatt 6
							Seite 6 / 11

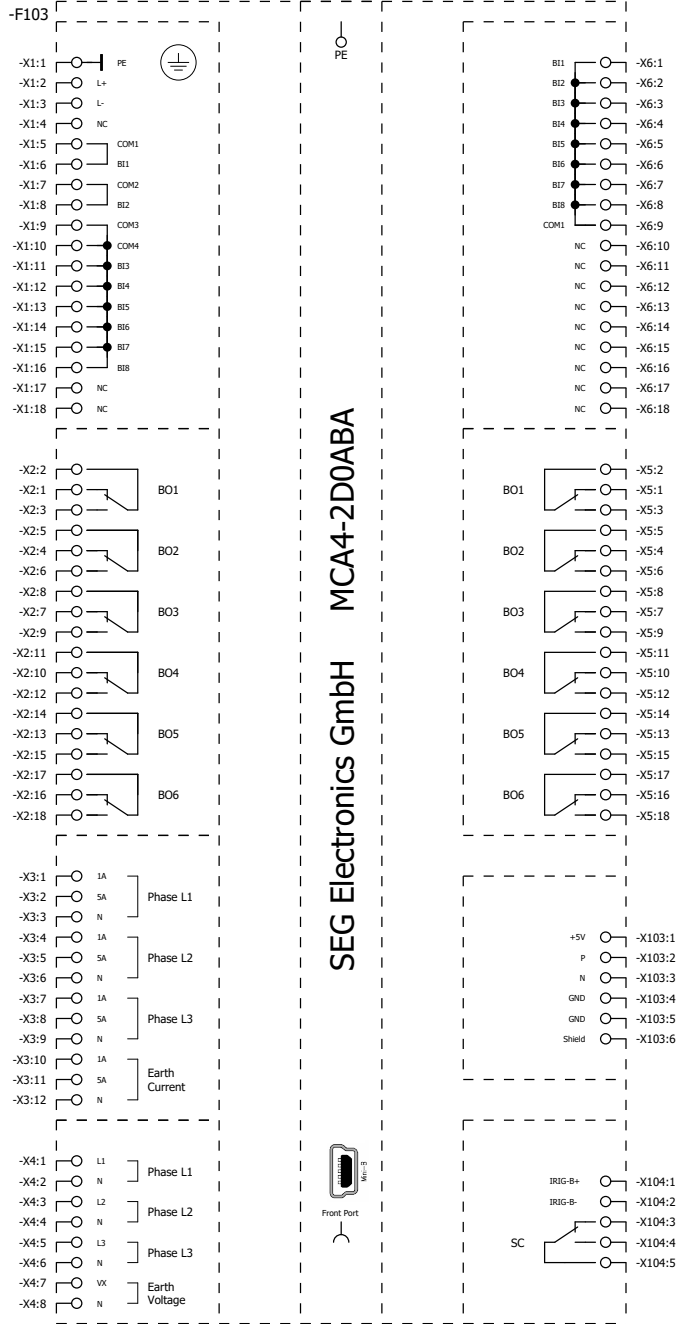

Datum	06.10.2023	SEG EPLAN MACRO	
Bearb.	dennis.voelkel		
Gepr		MCA4	
Änderung	Datum	Name	Urspr
			Ersatz von
			Ersetzt durch



MCA4-2D0ABA

SEG\_AB20231076

Blatt	7
Seite	7 / 11

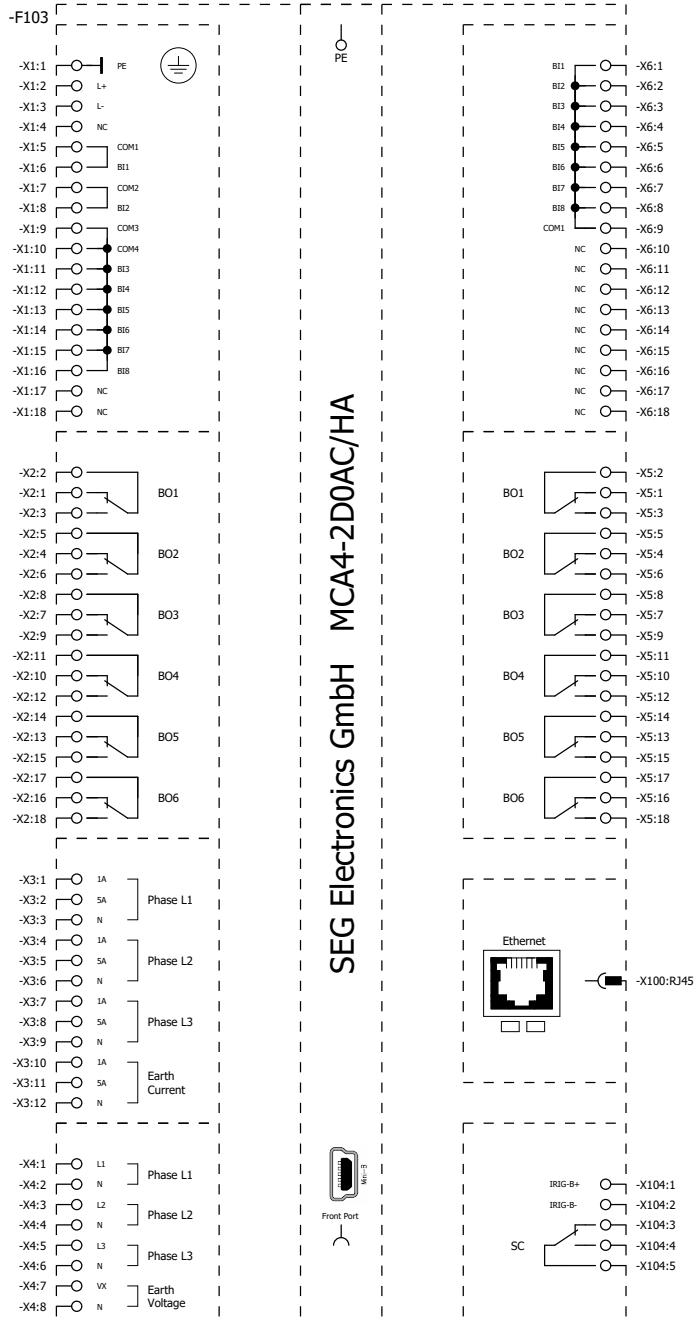

			Datum	06.10.2023	SEG EPLAN MACRO			MCA4-2D0AC_HA		=
			Bearb.	dennis.voelkel	MCA4					+
			Gepr							
Anderung	Datum	Name	Urspr		Ersatz von	Ersetzt durch				Blatt 9
									SEG_AB20231076	Seite 8 / 11



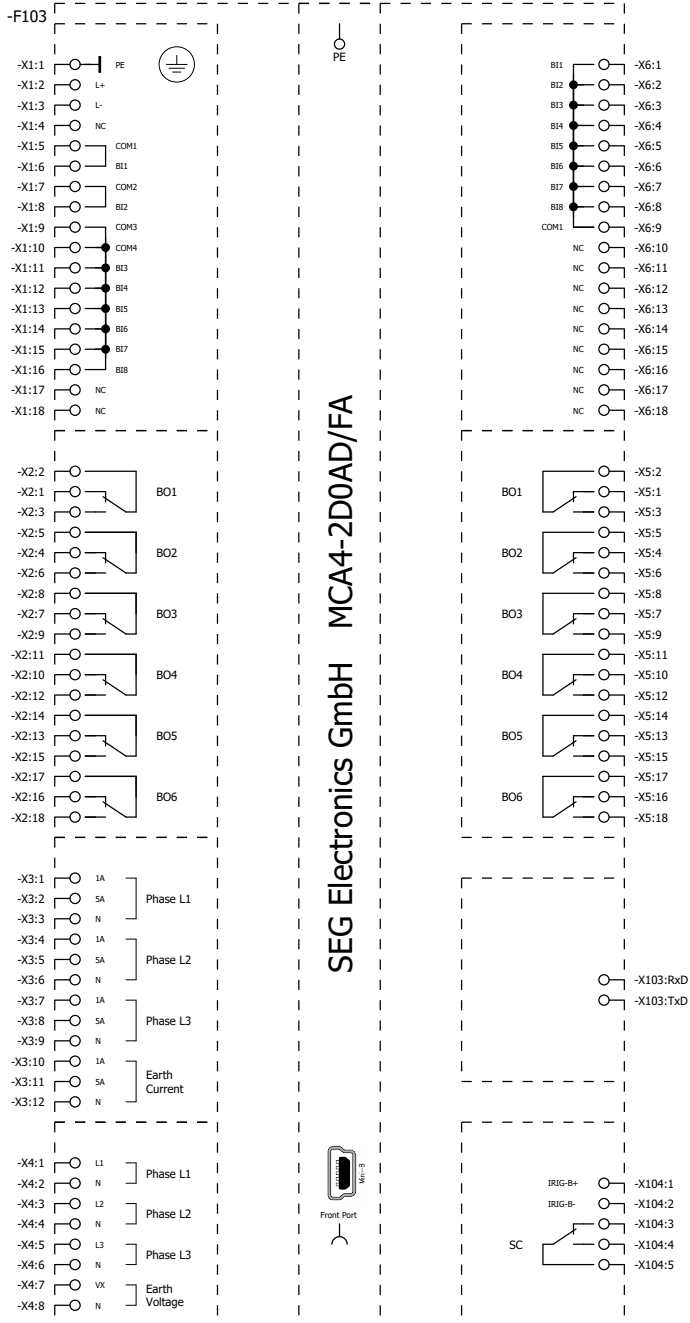

Datum	06.10.2023	SEG EPLAN MACRO	
Bearb.	dennis.voelkel	MCA4	
Gepr		Ersatz von	Ersetzt durch
Änderung	Datum	Name	Urspr



MCA4-2D0AD\_FA

SEG\_AB20231076

Blatt 10  
Seite 9 / 11

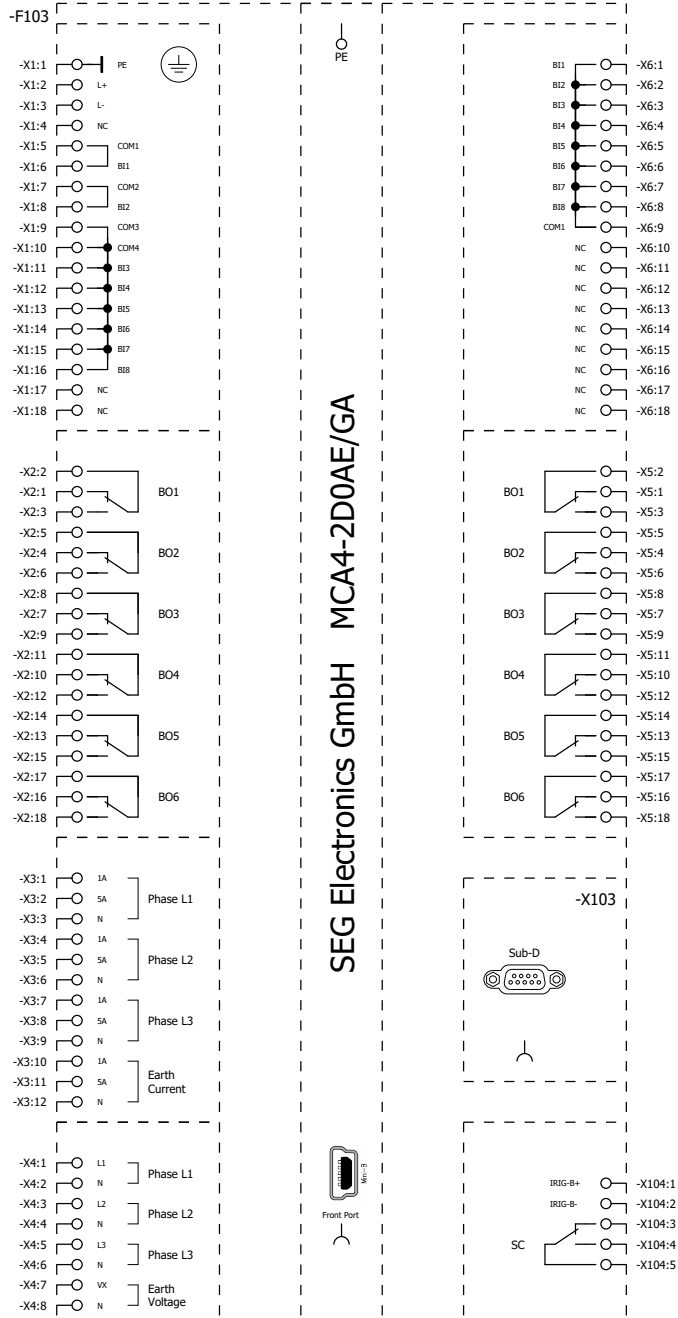

Datum	26.10.2023	SEG EPLAN MACRO
Bearb.	dennis.voelkel	
Gepr		MCA4
Urspr		Ersatz von
Ersetzt durch		



MCA4-2D0AE\_GA

SEG_AB20231076	Blatt 11
	Seite 10 / 11

