

# MANUAL

HighTECH Line | PROTECTION TECHNOLOGY  
MADE SIMPLE

MRM3 | MOTOR PROTECTION RELAY



## MOTOR PROTECTION RELAY

Original document

English

Revision: B

**SEG Electronics reserves the right to update any portion of this publication at any time.  
Information provided by SEG Electronics is believed to be correct and reliable.  
However, no responsibility is assumed by SEG Electronics unless otherwise expressly undertaken.**

**© SEG Electronics 1994–2020. All rights reserved.**

## Contents

<b>1.</b>	<b>Introduction and Application .....</b>	<b>6</b>
<b>2.</b>	<b>Characteristics and Features .....</b>	<b>7</b>
<b>3.</b>	<b>Design .....</b>	<b>8</b>
3.1	Connections .....	8
3.1.1	Analog Inputs .....	9
3.1.2	Output Relays .....	9
3.1.3	Digital Inputs .....	10
3.1.4	Low/High Range of the Digital Inputs .....	10
3.2	Front plate .....	11
3.2.1	Indicating LEDs .....	12
3.2.2	Adjusting LEDs .....	12
3.3	Analog part .....	12
3.4	Digital part .....	13
<b>4.</b>	<b>Working Principle .....</b>	<b>14</b>
4.1	Start Recognition .....	14
4.1.1	Criteria for Blocking the Start .....	16
4.2	Starting time .....	18
4.3	Thermal Image .....	18
4.4	Requirement on the Main Current Transformers .....	19
<b>5.</b>	<b>Operation and Adjustments .....</b>	<b>20</b>
5.1	Displayed text for parameter settings .....	20
5.2	Setting Procedure .....	21
5.3	System parameters .....	21
5.3.1	Presentation of Measuring Values as Primary Quantities on the Display ( $I_{\text{prim}}$ Phase) .....	21
5.3.2	Rated -Frequency .....	21
5.3.3	Operating Hour Meter (h) .....	21
5.3.4	Number of Motor Starts (No.) .....	21
5.3.5	Indication of pickup .....	21
5.3.6	Parameter Set Changeover Switch (P2) .....	22
5.4	Protection Parameters .....	22
5.4.1	Thermal Overload Protection ( $k \times I_B$ ) .....	22
5.4.2	Warning/Tripping with thermal Overload .....	22
5.4.3	Tripping Delay for Thermal Overload .....	22
5.4.4	Heating Period Constant $\tau_W$ and Cooling-Down Time Factor $\tau_C$ .....	22
5.4.5	$t_{2x}$ and $t_{6x}$ Minimal Trip Time During the Starting Process .....	23
5.4.6	Phase Undercurrent Element ( $I_{<}$ ) .....	23
5.4.7	Phase Over current Element ( $I_{>}$ ) .....	23
5.4.8	Trip Characteristics for the Phase Over current Element ( $I_{>}$ +CHAR) .....	23
5.4.9	Tripping Time or Time Factor for the Phase Over current Element ( $I_{>}$ + $t_{>}$ ) .....	24
5.4.10	Reset Mode for the Trip Characteristics in the Phase Current Path ( $I_{>}$ +CHAR+ $t_{>}$ ) .....	24
5.4.11	Phase Short-Circuit Trip ( $I_{>>}$ ) and ( $I_{>>}$ +Start) .....	24
5.4.12	Negative Phase Sequence .....	25
5.4.13	Earth Fault Element ( $I_{E>}$ ) .....	25
5.4.14	Switching Over Warning/Tripping .....	25
5.4.15	Trip Characteristics for the Earth-Fault Element ( $I_{E>}$ +CHAR) .....	25
5.4.16	Tripping Time or Time Factor for the Earth Fault Element ( $I_{E>}$ + $t_{>}$ ) .....	26
5.4.17	Reset Time for the Earth Fault Element ( $I_{E>}$ +CHAR+ $t_{>}$ ) .....	26
5.4.18	Tripping Time for the CB Failure-Protection (CB+ $t_{>}$ ) .....	26
5.4.19	External Trip (delayed)(Trip+ $t_{>}$ ) .....	26
5.4.20	Trip Blocking in case of Excessive Phase Current (Trip+Block) .....	26
5.5	Start Supervision .....	27
5.5.1	Duration of a Start Cycle (No.+Start) .....	27
5.5.2	Number of Starts per Cycle (No.+Start) .....	27
5.5.3	Start Blocking Time (Start+Block+ $t_{>}$ ) .....	27
5.5.4	Characteristic for the Starting Time .....	27
5.5.5	Rated starting current $I_{\text{Start}}$ .....	27
5.5.6	Maximal Start Time (Start+ $t_{>}$ ) .....	28

5.5.7	Start-up recognition time or Motor Running time.....	28
5.5.8	Stopping time.....	28
5.6	Interface Parameters.....	28
5.6.1	Adjustment of the Slave-Address (RS).....	28
5.6.2	Adjustment of the Baud-Rate (only for Modbus Protocol).....	28
5.6.3	Adjustment of the Parity (only for Modbus-Protocol).....	28
5.7	Recorder (FR).....	29
5.7.1	Fault Recorder or Disturbance Recorder.....	29
5.7.2	Number of Fault Recordings.....	30
5.7.3	Adjustment of the Trigger Event.....	30
5.7.4	Pre-Trigger Time ( $T_{vor}$ ).....	30
5.8	Setting of the Clock.....	31
5.9	Additional Functions.....	32
5.9.1	Blocking of the Protective Functions.....	32
5.9.2	Allocation of the Reset Functions.....	33
5.9.3	Allocation of the Output Relays.....	34
5.10	Measuring Value and Fault Indications.....	36
5.10.1	Measuring Value Indications.....	36
5.10.2	Units of the Displayed Measuring Values.....	36
5.10.3	Indication of the Fault Data.....	36
5.10.4	Fault Memory.....	37
5.11	Reset.....	38
5.11.1	Erasure of the Fault Memory.....	38
5.11.2	Reset of the Thermal Memory.....	38
5.12	Digital Inputs.....	39
5.12.1	Parameter Set Changeover Switch.....	39
5.12.2	External Trigger of the Fault Recorder.....	39
5.12.3	Recognition of "Motor Running" Condition.....	39
5.12.4	Undelayed External Trip.....	39
5.12.5	Delayed External Trip.....	39
<b>6.</b>	<b>Notes on Relay Tests and Commissioning.....</b>	<b>40</b>
6.1	Connection of the auxiliary voltage.....	40
6.2	Testing of Output Relays and LEDs.....	40
6.3	Test circuit for MRM3-2.....	41
6.3.1	Checking of Input Circuits and of the Measuring Values.....	41
6.3.2	Testing the START-STOP-RUNNING Recognition.....	41
6.3.3	Testing the Pick-Up and Disengaging Values.....	42
6.3.4	Testing the maximum starting time.....	42
6.3.5	Testing the thermal image.....	42
6.3.6	Testing the Control Inputs.....	42
6.3.7	Testing the CB Failure Protection.....	42
6.4	Primary Test.....	43
6.5	Maintenance.....	43
<b>7.</b>	<b>Technical Data.....</b>	<b>44</b>
7.1	Measuring input.....	44
7.2	Common data.....	44
7.3	Setting ranges and steps.....	45
7.3.1	System parameter.....	45
7.3.2	Time over current protection.....	46
7.3.3	Load Unbalance Protection.....	48
7.3.4	Earth fault protection.....	49
7.3.5	Circuit breaker failure protection.....	50
7.3.6	External trip delay.....	50
7.3.7	Trip blocking beginning with the adjusted rated current.....	50
7.3.8	Start parameter.....	51
7.3.9	Interface parameter.....	52
7.3.10	Fault recorder parameter.....	52
7.4	Tripping characteristics.....	53
7.4.1	Tripping characteristic for max. starting time.....	53
7.4.2	Thermal image.....	54

---

7.4.3	Initial load factor .....	54
7.4.4	Tripping of t2x and t6x - times.....	55
7.4.5	Inverse time over current protection.....	56
7.4.6	Trip characteristics .....	57
7.4.7	Inverse Time Characteristic for Load Unbalance.....	61
7.5	Output relays .....	61
<b>8.</b>	<b>Order form .....</b>	<b>62</b>

# 1. Introduction and Application

---

The motor protection relay MRM3-2 offers reliable protection for LV and MV motors which are either operated via power contactors or power circuit breakers.

The following functions are integrated into this relay:

- Overload protection acc. to IEC 255-8 in consideration of the initial load factor (thermal image)
- Definite undercurrent protection
- Definite time over current protection (DMT)
- Inverse time over current protection (IMT) with select-able trip characteristics
- Short-circuit protection
- Load unbalance supervision with definite or inverse trip characteristics
- Earth-fault detection with suppression of harmonics

The MRM3-2 recognizes the "Start-Up" and "Motor Running" phase.

Motors with a limited number of starts can be controlled by the start limiting function of the relay.

The earth-fault supervision is either realized in Holm-green connection or by means of a core-type current transformer.

The motor can be stopped in delayed or undelayed mode via digital inputs.

The MRM3-2 is available with rated currents of 1A or 5A.

**Important:**

For additional common data of all MR-relays please refer to manual "MR - Digital Multifunctional relays". On page 45 of this manual you can find the valid software versions.

## 2. Characteristics and Features

---

- Microprocessor technology with self-supervision,
- Measuring of phase currents as RMS value,
- Digital filtering of the earth current with discrete Fourier analysis, by which the influence of interference signals, such as harmonics and transient DC components during an earth-fault are suppressed.
- Two sets of parameters,
- Operating hour meter,
- Complies with the requirements of IEC 255-8, VDE435, part 301-1 for overload relays,
- Definite time undercurrent protection,
- Selectable protective functions : Definite time over-current protection (DMT) and inverse time over current protection (IMT)
- Selectable IMT trip characteristics of IEC 255-4:
  - Normal inverse (Type A)
  - Very inverse (Type B)
  - Extremely inverse (Type C)
  - Special-purpose characteristics
- Reset mode for DMT/IMT trip characteristics is selectable,
- Definite element for short-circuit high-speed trip
- Single-step earth fault supervision,
- Load unbalance protection with inverse or definite trip characteristics (NPS),
- CB failure protection,
- Display of the measuring values as primary quantities,
- Measuring of the phase currents during short-circuit free operation,
- Blocking of the individual protective elements or the trip elements can be set freely,
- The protective functions can be freely allocated to the output relays. (Relay Matrix),
- Suppression of an LED indication after activation (LED flash),
- „Manual/Automatic“ reset function of the trip elements adjustable via the configuration matrix,
- Saving of trip values and the switch-off times ( $t_{CBFP}$ ) of 25 fault events (voltage fail-safe)
- Recording of up to 8 fault events with time stamp,
- Display of date and time,
- Trip via digital inputs,
- Rack mounting, with self-acting short-circuit mechanism for CT circuits,
- Possibility of serial data exchange via the RS485 interface, optionally with RS485 Pro-Open-Data Protocol or Modbus Protocol.

# 3. Design

## 3.1 Connections

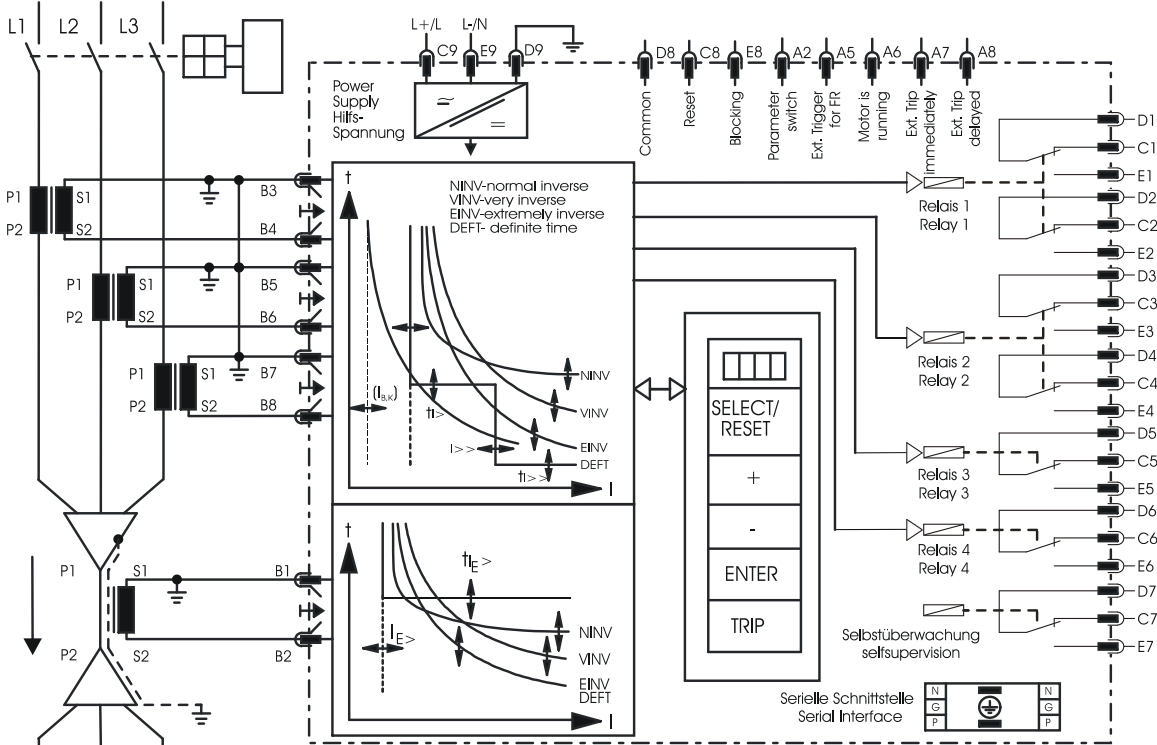

Figure 3.1: Connection Diagram MRM3-2

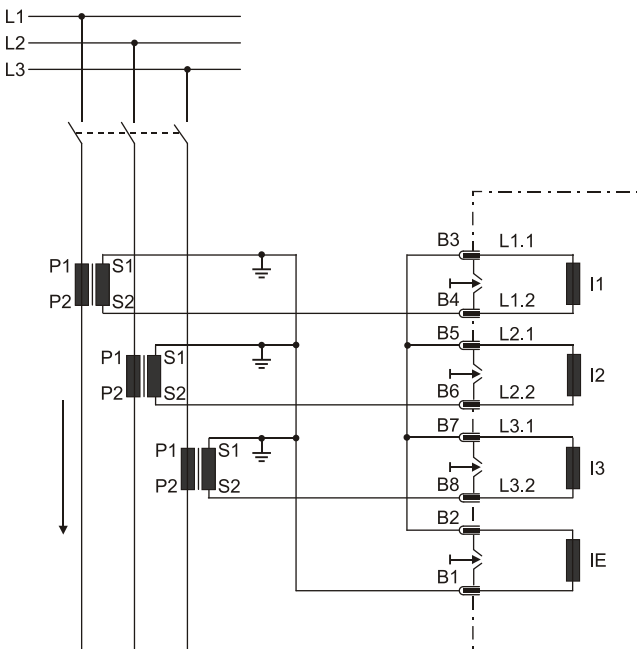

Figure 3.2: Measuring of phase currents and earth current detection in Holmgreen connection (IE)

This kind of connection can be used where three phase CTs are available and a combination of phase and earth current measuring is required.



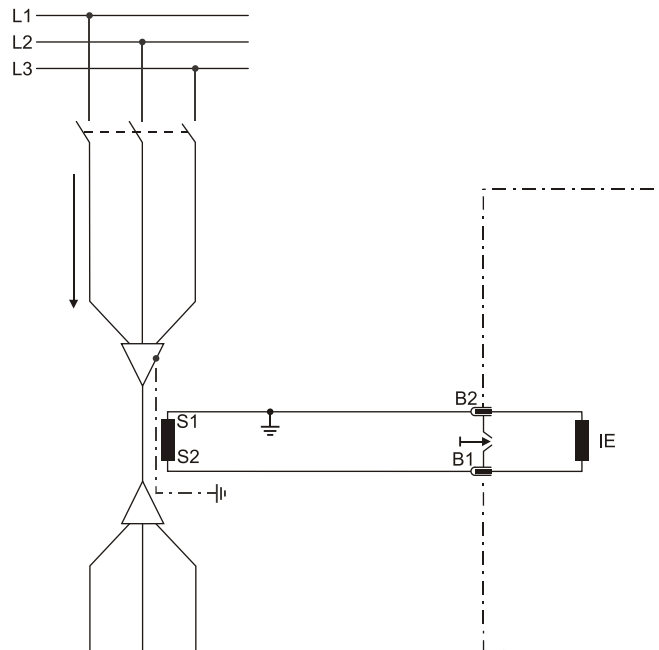

Figure 3.3: Measuring of earth current with core-type CT ( $I_E$ )

With the combination of phase and earth current measuring, CTs to be connected according to Figure 3.2. and Figure 3.3.

### 3.1.1 Analog Inputs

The analog input signals of the phase currents  $I_{L1}$  (B3 - B4),  $I_{L2}$  (B5 - B6),  $I_{L3}$  (B7 - B8) and the earth current  $I_E$  (B1 - B2) are fed to the protection device via separate input CTs.

The current measuring quantities are galvanic decoupled, analogously filtered, and then fed to the analog/digital converter.

### 3.1.2 Output Relays

The MRM3-2 has 5 output relays. Two of these relays with two change-over contacts and three relays with one change-over contact each are used for signaling. The protective functions can be freely allocated except of those for the self-supervision relay.

- Relay 1: C1, D1, E1 and C2, D2, E2
- Relay 2: C3, D3, E3 and C4, D4, E4
- Relay 3: C5, D5, E5
- Relay 4: C6, D6, E6
- Relay 5: Self-supervision C7, D7, E7

All relays are operating according to the n. o. principle with the exception of the self-supervision relay, which operates acc. to the n. c. principle.

### 3.1.3 Digital Inputs

The MRM3-2 has 7 digital inputs with fixed functions. All inputs have a common reference point : Terminal D8. (See Chapter 3.1)

No	Terminal	Function	Coding Plug
1	C8	External reset	2
2	E8	External blocking	1
3	A2	Parameter set change-over switch	3
4	A5	External trigger for the fault recorder	4
5	A6	Identification „Motor Running“	7
6	A7	Ext. trigger, undelayed	6
7	A8	Ext. trigger, delayed	5

### 3.1.4 Low/High Range of the Digital Inputs

The MRM3-2 is equipped with a wide-range power supply unit and hence the supply voltage is freely selectable. The switching threshold of the digital inputs, however, has to be fixed in compliance with the supply voltage. Two different switching thresholds can be adjusted:

Range	Plug	U <sub>not active</sub>	U <sub>active</sub>
Low	Plugged in	$\leq 8V$	$\geq 10V$
High	Open	$\leq 60V$	$\geq 80V$

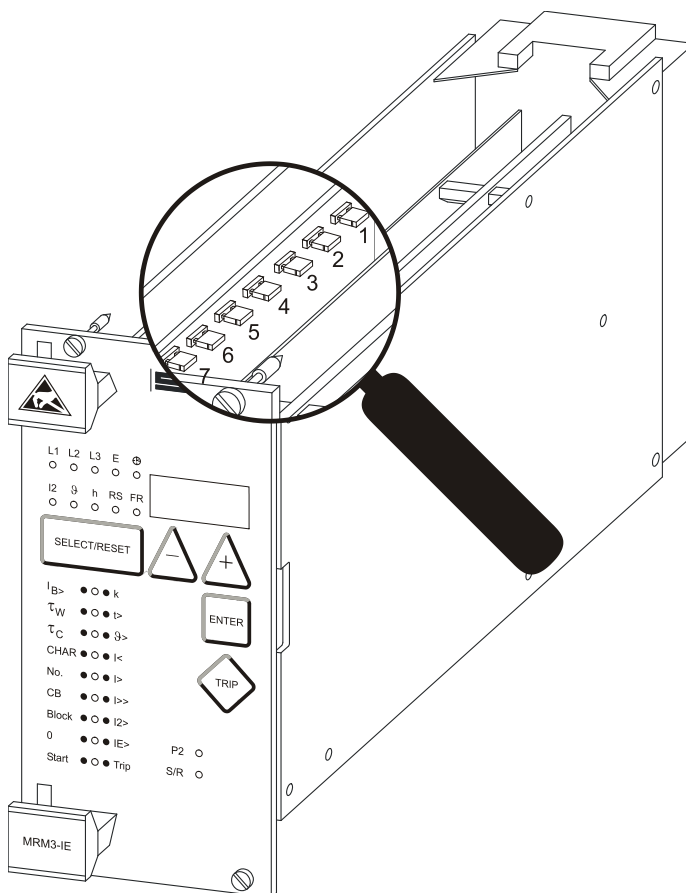

Figure 3.4: Coding Plug

### 3.2 Front plate

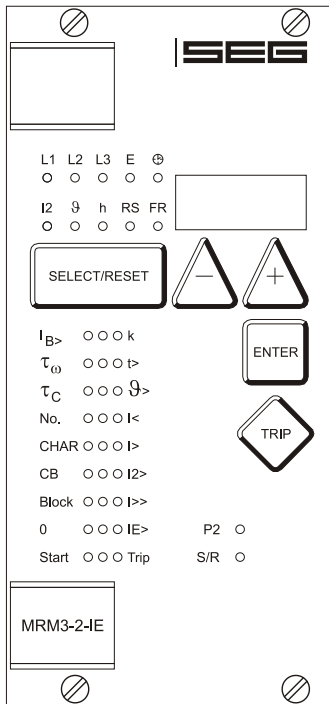

Figure 3.5: Front plate MRM3-2-IE

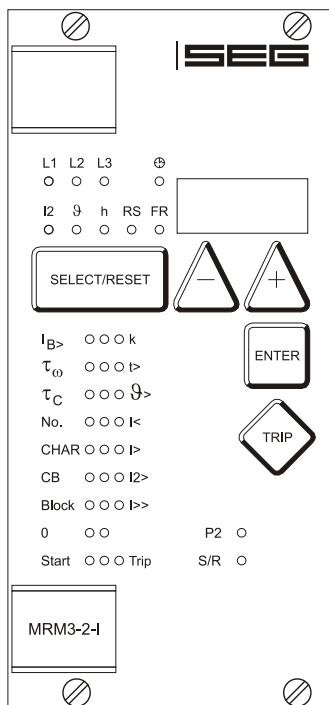

Figure 3.6: Front plate MRM3-2-I

The LEDs  $\oplus$ , h, RS and FR on the MRM3-2 emit a yellow light, all other LEDs are bi-colored. The LEDs at the left next to the alphanumeric display give a green light during measuring and a red one when a fault signal occurs.

The LEDs underneath the <SELECT/RESET> - push but-ton emit a green light during adjustment and inquiry of the setting quantities left to the LEDs. They show a red light if the printed setting quantities right to the LEDs are activated.

### 3.2.1 Indicating LEDs

L1, L2, L3	Indication of the phase currents
E	Indication of the earth current
I2	Indication of the unbalanced load current (NPS)
g	Indication of the temperature equivalent
h	Operating hour meter
$\oplus$	Date and time

### 3.2.2 Adjusting LEDs

IB>	Rated motor current
K	Constant quantity ( $k \cdot IB = 100\%$ thermal load)
$\tau_w$	Heating period constant
$\tau_c$	Cooling down factor
t>	Tripping times, generally
g>	Switching threshold of the thermal overload alarm
No.	Number of motor starts
CHAR	Characteristics setting
I<	Undercurrent setting
I>	Over current setting
I2>	Load unbalance setting (NPS)
I>>	Short-circuit setting
IE>	Earth current setting
CB	CB failure protection
Block	Start blocking/Protective blocking
0	Current>0/<0 START/STOP recognition
Start	Start blocking/Start time
Trip	External trip
FR	Parameter for the fault recorder
RS	Setting of the relay address
P2	Parameter set 2 is active
S/R	Motor starting/Motor running

## 3.3 Analog part

The alternating currents injected by the CTs are converted into galvanical isolated voltages via input transmitters and burden in the analog part.

The effect of inductive and capacitive coupled interferences are suppressed by RC analog filters. The measuring voltages are fed to the analog inputs (A/D trans-former) of the micro-processor and then converted into digital signals by means of sample and hold circuits. These digitized values are then used for further processing. The measuring values are acquired at  $f_n = 50$  Hz ( $f_n = 60$  Hz) with a sampling frequency of 800 Hz (960 Hz), and thus the instantaneous values of the measured quantities are acquired every 1.25 ms (1.04 ms).

### 3.4 Digital part

The protection relay is equipped with a powerful micro-controller, being the core element of the protection unit. With this micro-controller all tasks are completely digitally processed, from discretisation of the measuring quantities to protective tripping.

With the protection program, stored in the program storage (EPROM), the micro-processor processes the voltages applied to the analog inputs and from this calculates the fundamental harmonics of the current. Digital filtering (DFFT-Discrete Fast-Fourier-Transformation) for suppression of harmonics as well as suppression of DC components during the short-circuit is used in the process. The micro-processor compares the existing current with the threshold value (setting value) stored in the parameter storage (EEPROM) and up-dates the thermal image. If a current exceeds the threshold value for longer than the trip delay or if the thermal image exceeds its rated value, a fault signal occurs. Dependent on their settings, the output relays pick up as well. When setting the parameters, all setting values are read-in by the micro-processor and saved in the parameter storage.

The program flow is continuously monitored by the incorporated "Hardware-Watchdog". Processor failure is signaled by the "Self supervision" output relay.

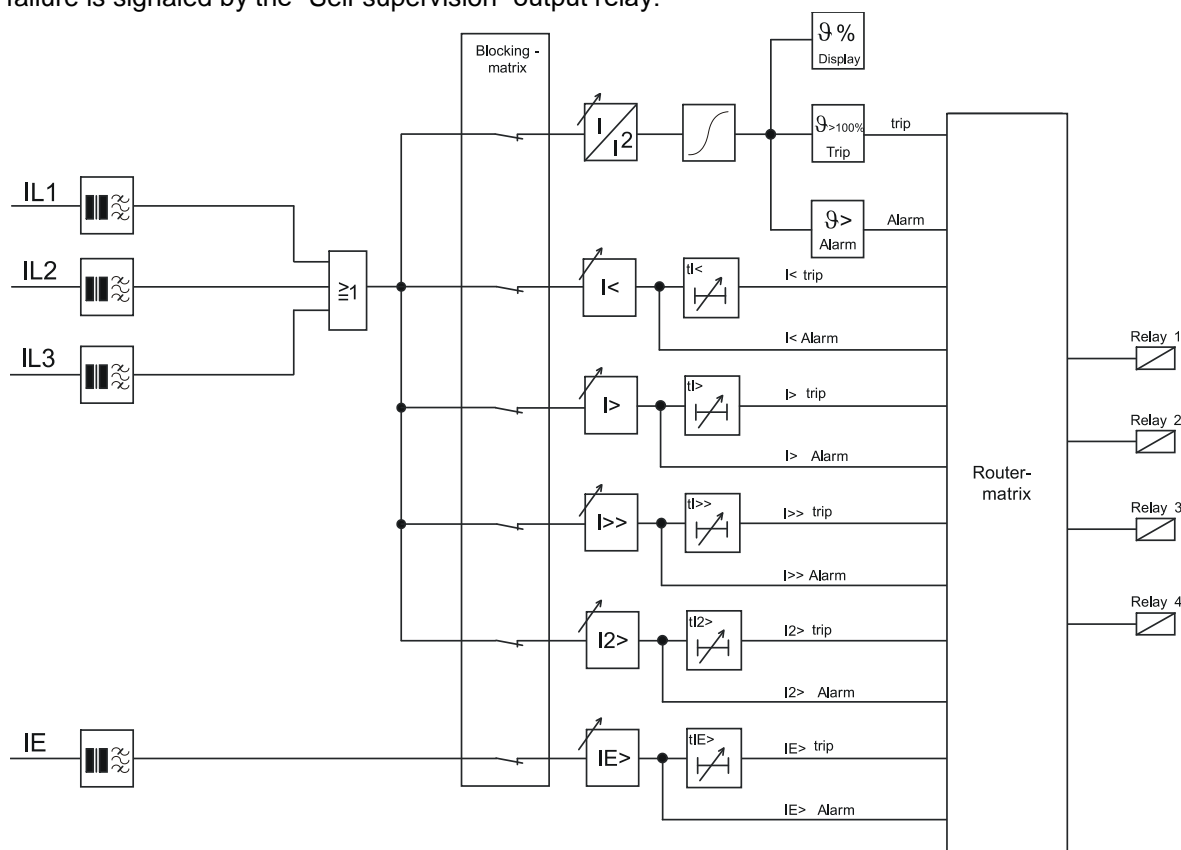

Figure 3.7: Block Diagram of Protective Functions

## 4. Working Principle

### 4.1 Start Recognition

The MRM3-2 monitors the flow of the current from which the following operational conditions of the motor are gathered.

- STOP
- START
- RUNNING

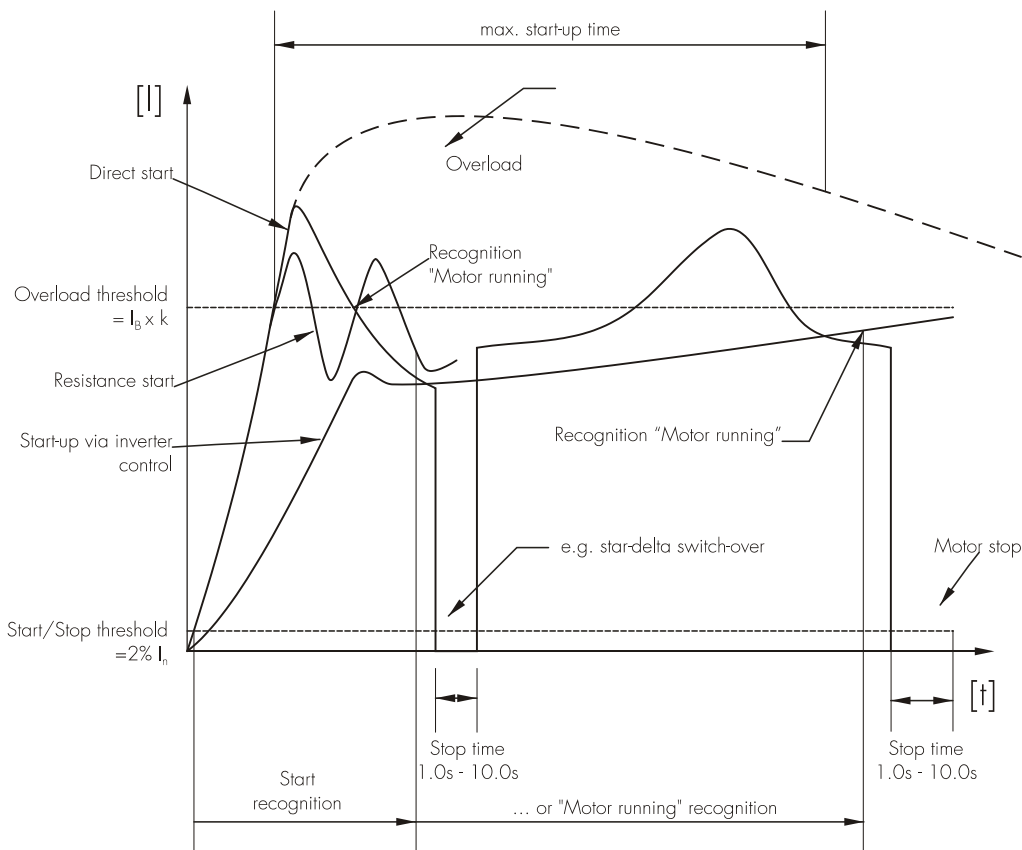

Figure 4.1: Different Start-Up Behavior of Motors

#### STOP - Condition:

If no current can be measured ( $I < \text{Stop threshold}$ ), STOP conditions are recognized after expiration of the stop time.

#### Start/Stop Threshold

This threshold is fixed at 2% of  $I_N$

#### Stop time:

The Stop time is adjustable in order to tolerate a brief off-time of the current flow (e.g. change-over Star/Delta) from the START or RUNNING conditions. STOP is only indicated if the current was under 2%  $I_N$  for longer than the stop time. Based on this time the running down period can be considered in a certain way for the LED indication.

#### START-Condition:

START is only recognized if the previous condition was STOP and the motor current has exceeded the start threshold. If the STOP or RUNNING conditions are recognized, the START condition is terminated.

**Overload Threshold:**

This corresponds to the permissible thermal continuous current  $k \times I_B$  and is adjusted by the parameter of the thermal image.

**Starter Recognition Time:**

This adjustable time has only to be extended for special start procedures in order to prevent that the RUNNING conditions are indicated too early in advance.

- No exceeding of the start threshold during pony motor start-up or when soft starters are used.
- Multistage resistance start where the start threshold is either exceeded several times or not at all.

The time is running from the instance the start threshold is exceeded. RUNNING is only accepted by the supervision after the time has elapsed or the overload threshold is undershot. If the overload threshold is not a clear criterion, the time has to be set at least for so long that the longest regular start procedure is covered.

RUNNING can be recognized in different ways:

- If the START has been successfully completed. This is the case when the motor current has dropped below  $k \times I_B$  and the start recognition time has elapsed. (direct start)
- or
- if the motor is connected across several resistance steps, it is possible that the start threshold is passed through repeatedly. RUNNING conditions are recognized when the start recognition time has run out after the last step and a current has settled between 2%  $I_N$  and  $k \times I_B$ . (Resistance start).
  - if after STOP a motor current has settled between 2%  $I_N$  and  $k \times I_B$  and the start recognition time has elapsed. The overload threshold has not necessarily to be exceeded. (soft start)
  - If the «Motor Running» input was activated but the overload threshold is not (or not any longer) exceeded. (See Chapter 5.12.3 )
- With the recognition of STOP, the RUNNING conditions have ceased to exist.

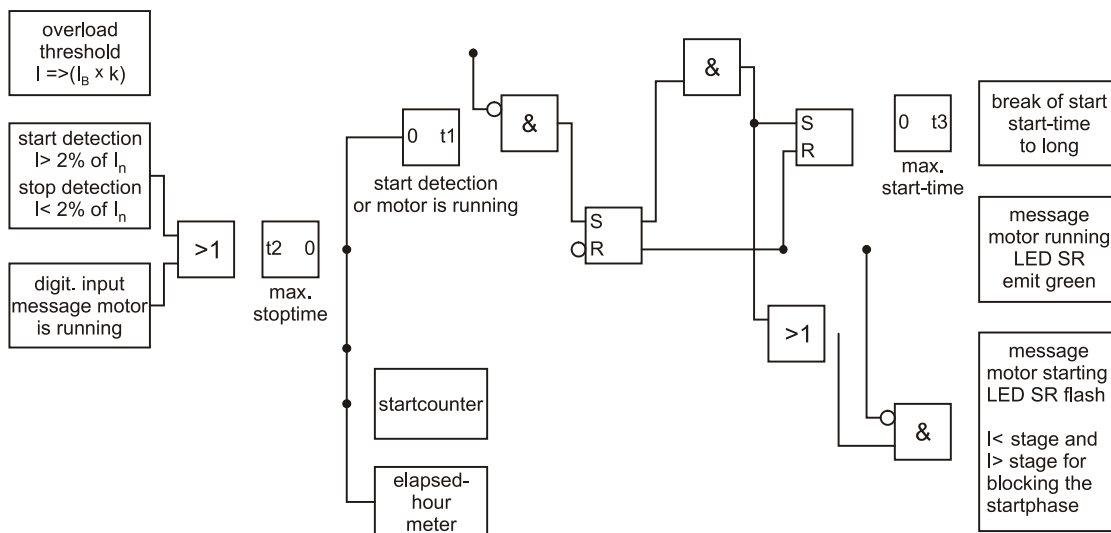

Figure 4.2: Flow Diagram of the Start Conditions

### 4.1.1 Criteria for Blocking the Start

**Number of monitored starts :**

The MRM3-2 is equipped with a flexible supervision element which can limit the sequence of possible starts.

A start should be prevented if it is obvious that it is likely to be interrupted due to overload so that in total the down-time can be curtailed. If a start is not recommendable at a certain time (with the motor switched off), the MRM3-2 activates an allocated output relay until the waiting time has elapsed. Irrespectively of the adjustment of this element, the thermal image is always activated and shuts the motor down as soon as the thermal overload threshold is reached (due to a start or overload). The protective element can either be tied to the thermal image or be manually defined by the number of starts and cycle duration.

**Number of Starts/Cycle Duration**

These two are defined as parameters.

**Example:**

The motor should be allowed to be started three times an hour:

This means that in theory the motor can be started every 20 minutes (= 60 min/3).

From this it can be concluded that the load generated by the start procedure has decayed after these 20 minutes. If the motor would be successfully started three time in quick succession, an immediate fourth start would overload the motor. The start blocking relay would be activated and the next start would only be advisable after about 20 minutes. The protective element ensures that the start sequence is kept within safe intervals but that at least three starts are allowed during the given time frame. If the intervals between each start are long enough then even more than three starts an hour might be possible because the motor was able to cool down in the mean time. The delay can be firmly defined (through start blocking time) or be automatically ascertained (VARI) until the 20 minutes given in the example are over. The state of the thermal image has no influence on the delay

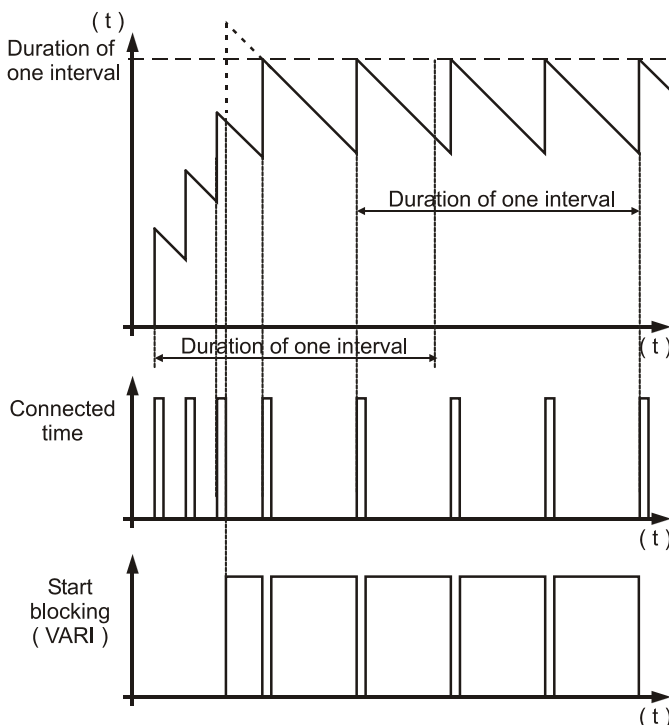

Figure 4.3: Relation Start Period/Start Blocking Time



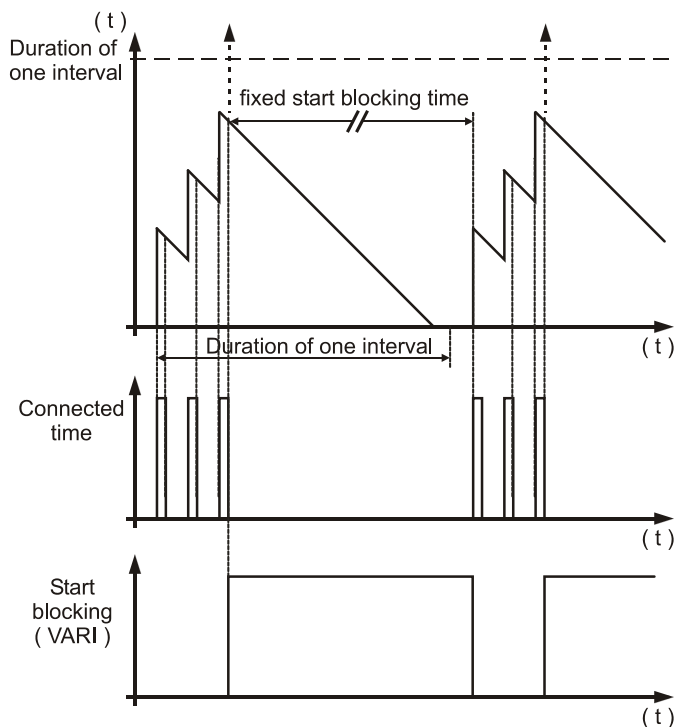

Figure 4.4: Relation Start Period/Start Blocking Time with firm Start Blocking Time

**Thermal Image**

A start is always possible as long as there is enough thermal reserve for a start. This start limitation is a dynamic one and is orientated on the data the thermal image is parameterized with. For this the MRM3-2 detects the average thermal load of the latest starts. With the motor shut down, the start blocking relay is activated for the time when there is not enough thermal re-serve in the stor-age through cooling down to enable a new start.

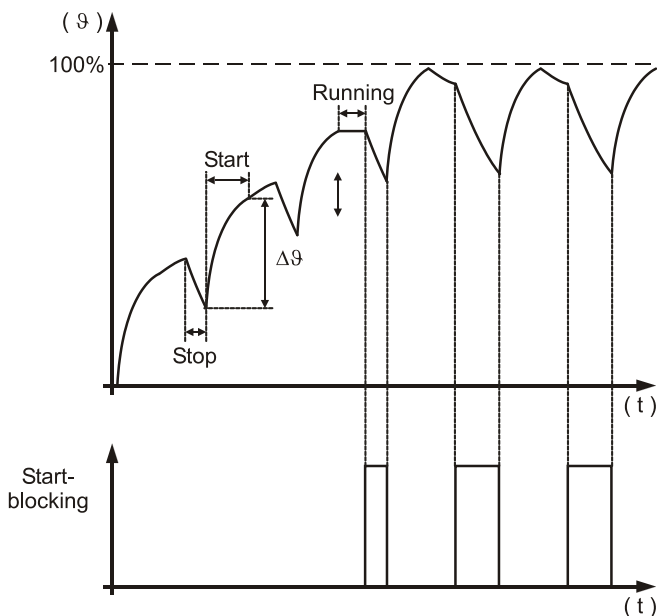

Figure 4.5: Start Blocking through Thermal Image

## 4.2 Starting time

With certain applications it is possible that the starting phase of the engines is extended. One reason for this insufficient terminal voltage which may be caused by the high starting current or by a high grid load in general. When starting under load, the starting phases must not be too long because this could overheat the motor. For these applications the MRM3-2 offers a variable maximum starting time. It refers to the rated starting current of the motor  $I_{Start}$ . If the actual starting current (e.g. at 80%  $U_N$ ) is lower than the rated starting current, the starting time is extended automatically.

$$Q = I^2 \times t_s$$

The supplied heat energy is equal to the square value of the current times the starting time. If the starting current decreases, the starting time can be extended. This time can be extended by a maximum of twice the set value. If the actual starting current is higher than its rated value, the max. starting time decreases (refer to Fig. 7).

## 4.3 Thermal Image

The fed thermal energy  $Q$  and the temperature  $\vartheta$  of the motor when in steady state condition is proportional to the square of the phase current (e.g. ohmic losses and iron losses):

$$Q \sim I^2 \quad \text{oder} \quad \vartheta \sim I^2$$

In the thermal image this temperature is described by the temperature equivalent  $\vartheta$  (in %). For loading with the maximal permissible operational current  $k \times I_B$ , the motor reaches the maximal permissible temperature  $\vartheta_B$ . If it has been in steady state condition for a certain time. For this load the thermal equivalent is defined to 100% = trip threshold:

Stationary final value:

$$\vartheta(\%) = \frac{I^2}{(k \cdot I_B)^2} \cdot 100\%$$

### Note:

When testing the thermal image it has to be taken into consideration that in case  $k \times I_B$  is slightly exceeded (= long tripping time), a small current change within the permissible measuring tolerances can cause a high dispersion of the tripping time (clearly by more than 1%). This is related to the slope of the trip characteristic. Furthermore it is important to start from the same initial level of the image when testing. Otherwise the tripping times may be shorter than expected.

### Automatic Reset

During the starting process the MRM3-2 observes the rise of the thermal image. From the average of the last two successful starts the unit detects the start load. After overload conditions, the thermal image is only released when the motor has cooled down far enough to deal with the demand of a new start.

## 4.4 Requirement on the Main Current Transformers

The CTs chosen have a considerable influence on the accuracy of the protective system. In order to select the right type of transformer, the requirements and conditions on site have to be considered carefully.

Type of Transformer

Current transformers have to be designed as protection transformers (P).

### **Over current Factor:**

To ensure precise operation of the protection unit even under full short-circuit current, the chosen transformers must not saturate in this current range. This means that the overload factor must be sufficiently large.

### **Class**

For the nominal range or the lower load range it has to be taken into account that not only the basic accuracy of the MRM3-2 has to be considered but also the transformer accuracy. This applies especially for cases where the Holmgreen circuit is used and for low earth fault currents in isolated networks.

### **Power Rating**

The transformer must be rated sufficiently to cover all measuring instruments and protective devices connected as well as the losses on the transformer measuring line without becoming overloaded.

## 5. Operation and Adjustments

### 5.1 Displayed text for parameter settings

Function	Displayed Text	Related LED	References
Normal operation	WW		
Exceeding the measuring range	max.	9	
Sec. transf. currents indication	SEK	L1, L2, L3,E	Chap. 5.3.1
Rated frequency	f = 50 / f = 60		Chap. 5.3.2
LED flashing after activation	FLSH/NOFL		Chap. 5.3.5
Parameter set change-over switch	SET1, SET2,	P2	Chap. 5.3.6
Blocking of a function	EXIT	LED of the blocked parameter	
Characteristics phase current	DEFT, NINV, VINV, EINV, LINV, RINV,	CHAR + I>	Chap. 5.4.8
Characteristics earth current	DEFT, NINV, VINV, EINV, LINV, RINV, RXIDG	CHAR + IE>>	Chap. 5.4.15
Characteristics	DEFT, INVS	CHAR + I2>	Chap. 5.4.12
Reset mode	0s / 60s	CHAR + I> + t> CHAR + I2> + t> CHAR + IE> + t>	Chap. 5.4.10 Chap. 5.4.17
Start blocking by thermal supervision	AUTO	Start + No	Chap. 5.5.1
Auto. definition of the remaining blocking time	VARI	Start + block + t>	Chap. 5.5.3
CB failure protection	CBFP	CB + t>	Chap. 5.4.18
Inquiry of the fault memory	FLT1, FLT2...	Trip = type dependent	Chap. 5.10.3
Erase fault memory	wait		Chap. 5.10.4
Relay tripped	TRIP	Trip = type dependent	
Reset the system	WW		
Password inquiry	PSW?	LED of the set parameter	
Hidden password	„XXXX“		Chap. 5.2
Parameter to be saved?	SAV?		
Save parameter !	SAV!		
Manual trip	TRI?		
Blocking of the protec. function	BLOC, NO_B, PR_B, TR_B	LED of the set parameter	
Relay assignment	z. B. _ 2 _ _	LED of the set parameter	
Trip signal for the fault recorder	P_UP; A_PI; TRIP; TEST	FR	Chap. 5.7.3
Number of fault events	S = 2, S = 4, S = 8	FR	Chap. 5.7.2
Indication of date and time	Y = 01, M = 01, D = 04, h = 12, m = 2, s = 12	⊕	Chap. 5.8
Slave address of the serial interface	1-32	RS	Chap. 5.6.1
Baud-Rate <sup>1)</sup>	1200-9600	RS	Chap. 5.6.2
Parity-Check <sup>1)</sup>	even odd no	RS	Chap. 5.6.3

Figure 5.1: Indication Possibilities via the Display

<sup>1)</sup> Modbus only

## 5.2 Setting Procedure

<SELECT/RESET>

short advancing the indication  
long reset

<ENTER>

Saving of an entry

Before parameters can be set a password is inquired (see chapter 4.4 of description "MR – Digital Multifunction Relay").

## 5.3 System parameters

### 5.3.1 Presentation of Measuring Values as Primary Quantities on the Display ( $I_{\text{prim}}$ Phase)

This parameter makes it possible to present the indications of phase current and earth-fault current separately, i.e as primary or secondary measuring value. Currents in the kilo ampere range are indicated with the symbol of unit of measurement k (kilo) as three-digit point.

**Example:**

A 1500/5 A CT is used with a primary current of 1380 A. The parameter for the CT primary current is given in kilo ampere.

- The parameter is set to "1.50" (kA). Then "1K38" is displayed as I-measurement.
- If the setting is set to "sec.", "0.92" x  $I_N$ . is displayed as I-measurement.

**Note:**

The settings for the pick-up value are adjusted to a multiple of the secondary rated CT current. The settings for phase and earth current transformers can be done separately.

### 5.3.2 Rated -Frequency

The FFT-Algorithm used for the data acquisition needs the set point of the rated frequency, i.e. 50 Hz or 60 Hz, for correct digital filtering of the earth current.

### 5.3.3 Operating Hour Meter (h)

As soon as the conditions START or RUNNING have been recognized, the operating hour meter starts. The meter can also be preset. Years and hours are shown in two windows. After every 8760 h the value is carried over to the window "Year". In the display the years are marked with the letter "Y" (engl.: year)

### 5.3.4 Number of Motor Starts (No.)

Every start is counted, even unsuccessful ones. The number of motor starts can be preset.

### 5.3.5 Indication of pickup

If the momentary current drops below the pickup threshold, e.g.  $I_>$ , after the relay was activated and there was no tripping, then the activation is signaled by short flashing of LED  $I_>$ . The LED keeps flashing until the <RESET> push-button is pressed. By setting the parameter to FLSH/NOFL, flashing can be suppressed.

### 5.3.6 Parameter Set Changeover Switch (P2)

By means of this switch two different parameter sets can be activated. The changeover procedure can be realized either by the software or via the digital input (A2). If the parameter set changeover switch is adjusted to "SET2", the active parameter set can be changed to "SET1" via the external input. If the changeover switch is set to "SET1", then it can be changed to "SET2" via the digital input.

The LED P2 on the front cover always indicates which of the parameter sets is active. Furthermore it is possible to indicate via an assigned output relay that parameter set 2 is active.

During the setting procedure the LED P2 gives off a yellow light.

## 5.4 Protection Parameters

### 5.4.1 Thermal Overload Protection ( $k \times I_B$ )

With the product of setting values  $k \times I_B$  the continuously permissible maximal current of the motor is adjusted. At this current the thermal image reaches 100 % after a long period – i.e. the trip threshold.

With  $I_B$  normally the rated current of the motor is adjusted and with  $k$  an overload factor (e.g. 1.05). It is also possible to adjust the maximal continuous current directly, if  $k = 1$  was selected.

### 5.4.2 Warning/Tripping with thermal Overload

Sometimes it is necessary that the thermal protection beyond the 100 % limit does not lead to shut-down (e.g. fire extinguisher pump). For this reason it is possible to differentiate between tripping and warning. In case of the warning function the display does not show "TRIP". The relay assigned to this step responds and should therefore be configured onto a different relay than the one leading to tripping.

### 5.4.3 Tripping Delay for Thermal Overload

The starting current of motors is normally many times higher than the rated current. In that case the threshold for recording the thermal overload  $k \cdot I_B$  is exceeded. The warning relay responds and the LEDs signal excitation. Excitation signaling remains active beyond the starting phase as well. Since starting of the motor is a normal process and not a malfunction, it is possible at this point to delay detection of the excitation for thermal overload. If the motor is overloaded often and this is permissible for a short period (e.g. breakers) it may also make sense to operate this overload with delay action. This delay is also effective in motor OPERATING mode and has no effect on the tripping behavior of the MRM3-2.

**Note:**

In this case, the signaling of the LED fulfills a special function: The excitation is always indicated without de-lay. If the excitation limit value is under-run within the delay time, there will be no "flash" function (see chapter 5.3.5).

### 5.4.4 Heating Period Constant $\tau_w$ and Cooling-Down Time Factor $\tau_c$

With this time constant the thermal image is adapted to the heating behavior of the motor. It is the time constant of an e-function.

Normally the motor is cooling down with a slower time constant. Parameter  $\tau_c$  is to be understood as a factor. The cooling-down behavior in the thermal model proceeds with the time constant  $\tau_c \times \tau_w$ . If  $\tau_c = 1$  is selected, then heating and cooling-down proceed at an identical speed in the thermal image.

### 5.4.5 t2x and t6x Minimal Trip Time During the Starting Process.

With this parameter the fastest trip time during the start-up phase is limited for the thermal image. If the selected pick-up value  $k \times I_B$  is exceeded by two times or six times, the characteristic breaks to definite time. This prevents that a higher start current causes the thermal image to overflow at the first instant. Normally six times the value is selected. If not desired, the characteristic can be operated without breaking by setting EXIT.

### 5.4.6 Phase Undercurrent Element (I<)

#### Running-dry protection/V-belt split

The MRM3-2 trips if after a successful start the current lies below the adjusted current threshold for a definite time. Undercurrent is only active during mode RUNNING. The undercurrent element is also blocked if the measured current lies below the STOP threshold (see chapter 4.1). EXIT is set, then this element is switched off.

The time delay for the undercurrent element is set to seconds.

#### Note:

The time delay must not be set shorter than the STOP time, otherwise every time the motor is stopped, an undercurrent trip occurs.

### 5.4.7 Phase Over current Element (I>)

When adjusting the pick-up value for the phase over-current element I>, an indicating value, referring to the secondary rated current  $I_N$ , is displayed. This element is only active during mode RUNNING.

### 5.4.8 Trip Characteristics for the Phase Over current Element (I>+CHAR)

There are the following standard trip time characteristics available (see 7.4.6:

DEFT	-	Definite Time (definite time over current protection)
NINV	-	Normal inverse
VINV	-	Very inverse
EINV	-	Extremely inverse
RINV	-	RI-Inverse
LINV	-	Long term Inverse

### 5.4.9 Tripping Time or Time Factor for the Phase Over current Element (I>+t>)

Normally, after change of the trip characteristics, the tripping time or the time factor also has to be changed accordingly. In order to avoid an unsuitable combination between trip characteristics and tripping time or time factor, the following measures are initiated by the MRM3-2:

The LED for adjustment of the tripping time or time factor (I> + t>) starts to flash after the trip characteristics have changed. By this warning signal the operator is reminded to adjust the tripping time or time factor to the changed operational mode or trip time characteristics. This warning signal keeps flashing until the tripping time or time factor are re-adjusted. If re-adjustment has not been done within 5 minutes (the time to enable parameter setting), then the processor sets the tripping time or time factor to the highest sensible value (smallest possible tripping time).

When adjusting to the "Definite Time" trip characteristic, the definite tripping time displayed is shown as seconds (e.g. 0.35 = 0.35s). By pressing push-buttons <+><-> this time can be changed step by step in the range 0.04s – 260s

When adjusting to the "Inverse Time" trip characteristics, the time factor (tI>) is displayed. This factor can be changed also by push buttons <+><-> step by step in the range 0.05 – 20.0.

If the tripping time or time factor are set to infinite long (on the display "EXIT" is shown) then trip of the relay over current element is blocked. The WARNING/ALARM function is still active. During this time LEDs I> and t> are red.

### 5.4.10 Reset Mode for the Trip Characteristics in the Phase Current Path (I>+CHAR+t>)

In order to ensure that the trip function is reliable even with repeated error pulses, each of them shorter than the set tripping time, the RESET mode for the trip characteristics can be changed over. With a setting of "60s" the elapsed tripping time is frozen and is only reset after 60s faultless operation. Should another fault occur within these 60s, the tripping time counter re-mains in operation. With the setting "\_ 0s" the counter is immediately reset when the fault current is interrupted and it is restarted when the fault current has returned again.

### 5.4.11 Phase Short-Circuit Trip (I>>) and (I>>+Start)

The short-circuit element has two threshold values and two time delays. The first threshold value applies for the mode RUNNING and the second one for mode START.

Possible variations are:

- During the start procedure the existing inrush current can be higher than the desired short-circuit threshold during operation. e.g. direct start)
- It is also possible that the slip rings are put at risk especially during the start procedure so that for START a more sensitive adjustment is required than for RUNNING.
- Both elements can be set to the same value so there is no differentiation.

If it is set to EXIT then the respective element is switched off.

Irrespectively of the selected trip characteristics for I>, the short-circuit high-speed trip element I>> has a trip-ping time which does not depend on the current. This time applies for both elements I>>START and I>>RUNNING.



### 5.4.12 Negative Phase Sequence

Load unbalance can, for example, be caused by a phase failure or fault in a one motor winding. Load unbalances give rise to negative phase sequence currents in the stator, causing odd harmonics in the stator winding and even harmonics in the rotor winding.

Especially the rotor is endangered by this because asymmetric conditions mean additional thermal stress for the rotor winding and eddy currents are induced in the solid iron of the rotor which can cause destruction of the metal structure or even melting of the metal.

Within certain limits and by observing the ultimate thermal strength of the motor, load unbalance is permissible, though. The details given by the motor manufacturer mostly refer to the negative phase sequence system and thus can be programmed directly.

According to the method of "Symmetric Components", a rotating three-phase system can be sectionalized into a positive phase sequence system, negative phase sequence system and a zero phase sequence system. The current in the negative phase sequence system is the measure for the load unbalance quantity. The effective value of the current of the negative phase sequence system  $I_2$  is calculated by the MRM3-2.

When setting the threshold value for the load unbalance current  $I_2$ , the indicated value referring to the rated current ( $I_N$ ) is displayed.

When adjusting the trip characteristics either « DEFT » for "definite" trip characteristics is shown on the display or « INVS » for "inverse" trip characteristics. (see chapter 7.4.7)

### 5.4.13 Earth Fault Element (IE>)

The setting procedure outlined in chapter 5.4.5 applies here as well. The required value in the  $0.01 \times I_N - 2.00 \times I_N$  range can be set with push-buttons <+> and <->.

### 5.4.14 Switching Over Warning/Tripping

An earth fault can be parameterized as follows. After the delay time has expired

- a) the warning relay responds (warning)
- b) the tripping relay responds (tripping)

The tripping values are stored in the fault recorder.

### 5.4.15 Trip Characteristics for the Earth-Fault Element (IE>+CHAR)

When adjusting the trip characteristics one of the following 7 abbreviations is displayed:

DEFT	-	Definite Time (definite time over current protection)
NINV	-	Normal inverse (Type A)
VINV	-	Very inverse (Type B)
EINV	-	Extremely inverse (Type C)
RINV	-	RI-Inverse
LINV	-	Long-term inverse
RXID	-	Special purpose characteristics

The displayed text can be changed by push-buttons <+><->. By pressing <ENTER> the required trip characteristics is selected. The allocated LED IE> is red, the LED CHAR green.

### 5.4.16 Tripping Time or Time Factor for the Earth Fault Element (IE>+t>)

The setting procedure outlined in chapter 5.4.9 applies here as well.

### 5.4.17 Reset Time for the Earth Fault Element (IE>+CHAR+t>)

The setting procedure outlined in chapter 5.4.10 applies here as well.

### 5.4.18 Tripping Time for the CB Failure-Protection (CB+t>)

This protection is activated after a protective trip and it monitors if all phase currents have dropped within the set time  $t_{CBFP}$  to  $<2\% \times I_N$ . If not, CB failure is detected and the allocated relay triggered. (CBFP= Circuit Breaker Failure Protection).

### 5.4.19 External Trip (delayed)(Trip+t>)

Via the digital input A8/D8 an external trip with time delay can be activated. Trip is initiated if the <signal existed for at least the set time. The external trip function can be allocated to a relay.

### 5.4.20 Trip Blocking in case of Excessive Phase Current (Trip+Block)

This function is important where power contactors are used and they are not designed to disconnect high short-circuit currents. In such a case no function of the MRM3-2 must initiate tripping. The trip function is then allocated to a preceding protective element (e.g. fuse). Trip blocking is activated as soon as the set current is exceeded. When this threshold is undershot, all function are released again.

If the circuit breakers used are able to disconnect the short-circuit current to be expected, the function is set to EXIT.

## 5.5 Start Supervision

The MRM3-2 can offer two start supervision methods:

- Automatically by means of the thermal load
- By a limited number of starts per time interval

### 5.5.1 Duration of a Start Cycle (No.+Start)

#### **AUTO**

If this mode is selected, a start is always possible if sufficient start reserves are available according to the thermal image. This function operates dynamically on the data of the previous starts (see chapter 4.1.1).

#### **Time Adjustment**

By this the interval of the permissible number of starts is timed.  
The number is defined in the next parameter.

#### **EXIT**

The element is deenergised.

### 5.5.2 Number of Starts per Cycle (No.+Start)

This parameter is only visible if a time was selected with the preceding parameter which defines the number of permissible starts during the respective interval.

### 5.5.3 Start Blocking Time (Start+Block+t>)

This parameter is only visible if a time was selected (chapter 5.5.1). It defines the time for a new start when the number of starts per interval was exceeded. The following is possible:

#### **VARI**

A new start is possible after the remaining time of the interval has run down.

#### **Time Adjustment (s):**

Restarts are blocked for the adjusted time.

### 5.5.4 Characteristic for the Starting Time

In some motor applications it may happen that the supply voltage is lower than the rated value. Lower rated values have lower starting currents and consequently longer starting times. The starting time can be extended by selecting a characteristic. The setting "DEFT" means that a maximum starting time is fixed. The subsequent parameter "Rated starting current" is not active. The setting "INVS" means that the maximum starting time is variable. It is determined by the rated starting current and the permissible starting time at rated voltage (refer to Chapter 7.4.1).

### 5.5.5 Rated starting current I\_Start

The basis for calculating the maximum starting time is the rated starting current I\_Start of the motor at rated voltage.

## 5.5.6 Maximal Start Time (Start+t>)

Exceedingly long acceleration can only be recognized if the threshold  $k \cdot I_B$  is once overshoot after the STOP threshold was exceeded.

### With the setting "DEFT"

The time meter for the max. start time is activated upon exceeding of the threshold  $k \cdot I_B$ . If the set time has elapsed and the current lies (still or again) above the START threshold, the start procedure is stopped. When mode RUNNING is recognized, this element is de-activated until the next start attempt.

### With the setting "INVS"

If the characteristic is selected for the maximum starting time, this parameter is valued as rated starting time/time multiplier  $t_s$  and multiplied by the calculated tripping time.

**Example:** If the starting current is lower than the rated starting current by the factor 0.707, the maximum starting time is doubled (refer to Chapter 7.4.1).

## 5.5.7 Start-up recognition time or Motor Running time

The start-up recognition time is a criterion for switching over to OPERATION. The MRM3-e recognizes the operating mode if the threshold  $I_B \cdot K$  is fallen short of and the start-up recognition time has expired. (refer to Chap. 4.1)

## 5.5.8 Stopping time

A motor is considered to be stopped if the measured current has fallen short of the value  $<2\% \cdot I_N$  and the set time has expired (refer to Chap. 4.1).

## 5.6 Interface Parameters

### 5.6.1 Adjustment of the Slave-Address (RS)

The Slave address can be adjusted in a range from 1-32.

### 5.6.2 Adjustment of the Baud-Rate (only for Modbus Protocol)

When the Modbus protocol is used for data transmission it is possible to adjust different transmission speeds (Baud rates).

### 5.6.3 Adjustment of the Parity (only for Modbus-Protocol)

For adjustment of the parity there are three options:

- "even" = even parity
- "odd" = odd parity
- "no" = no check of the parity

## 5.7 Recorder (FR)

### 5.7.1 Fault Recorder or Disturbance Recorder

The existing store can be utilized in two ways:

#### Not to be overwritten

Previous recordings will not be overwritten. When there is no memory space left, further recordings are not possible.

#### Overwrite

The latest fault incidents can always be called up; The eldest recording is overwritten by a new one.

Parameter Adjustment*	Mode	Time per Record (s)	
		50 Hz	60 Hz
S=1	overwrite	8.00	6.66
S=2	Not to be overwritten	8.0	6.66
S=3	overwrite	4.00	3.33
S=4	Not to be overwritten	4.00	3.33
S=7	overwrite	2.00	1.66
S=8	Not to be overwritten	2.00	1.66

\* s = total no. of recordings

Table 5.1:

The storage zone of the fault recorder is designed as ring buffer. In the example shown below storage of 7 fault recordings are possible (overwriting). The 8th segment serves as buffer store.

Memory space 6 to 4 is used.

Memory space 5 is needed for temporary storage of ongoing signals.

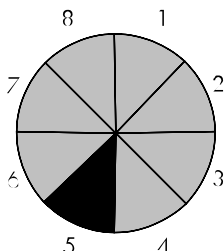

Figure 5.2: Partitioning of the store into 8 segments, for instance

This example shows that the store was used for more than 8 recordings because store spaces 6, 7 and 8 are used. From this it follows that no. 6 was the eldest recording and no. 4 the latest one.

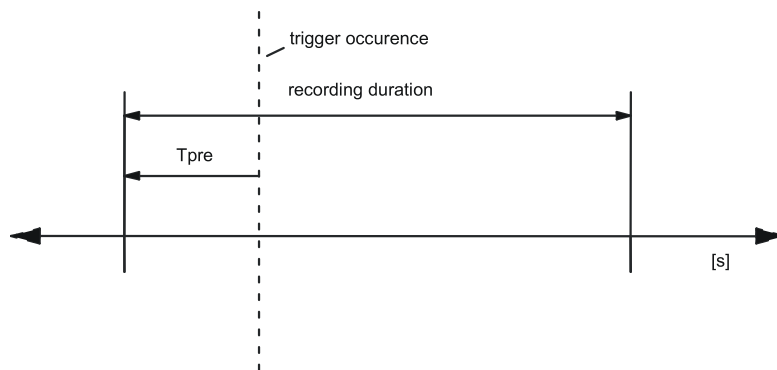

Figure 5.3: General Set-Up of the Fault Recorder

Each of the storage segments have a fixed storage time where the time before the trigger event can be defined.

Via the RS485 interface the data can be read out by means of a PC provided with HTL/PL-Soft4. The data is graphically edited and represented. Binary tracks are recorded additionally, e.g. activation and trip.

### 5.7.2 Number of Fault Recordings

The max. recording time is 16 s at 50 Hz or 13.33 s at 60 Hz.

The max. number of recordings to be stored has to be defined beforehand. There is the choice between (1)\* 2, (3)\* 4 and (7)\* 8 recordings. Hence the existing memory space can be used as follows:

(1)\* 2 recordings for 8 s at 50 Hz and 6.66 s at 60 Hz.

(3)\* 4 recordings for 4 s at 50 Hz and 3.33 s at 60 Hz.

(7)\* 8 recordings for 2 s at 50 Hz and 1.66 s at 60 Hz.

\* will be overwritten when a new trigger signal occurs.

### 5.7.3 Adjustment of the Trigger Event

There is the choice between four different trigger events:

P_UP (Pickup)	Data saving begins when a general activation is recognized.
TRIP	Data saving begins when a general trip is recognized.
A_PI (After Pickup)	Data saving begins when the last activation threshold is undershot (recognizes, for instance, CB failure protection)
TEST	Data saving is activated when push buttons <+> and <-> are pressed simultaneously (immediately upon pressing the buttons). For recording time, the mode TEST is displayed.

### 5.7.4 Pre-Trigger Time ( $T_{vor}$ )

The time  $T_{pre}$  defines the period to be saved prior to the trip event. This time can be set between 0.05 s and the max. recording time (2, 4 or 8 s). With push-buttons <+> and <-> the values can be changed and with <ENTER> they can be saved.

## 5.8 Setting of the Clock

When date and time are set, the LED „⌚“ is on. The following method is used:

Date:	year	Y=00
	month	M=00
	day	D=00

time:	hour	h=00
	minute	m=00
	second	s=00

Immediately when the supply voltage is applied the clock starts with the respective date and time. The time is buffered against short-term voltage failures (min. 6 minutes).

**Note:**

The window for setting the clock is behind the measuring value reading. Access to the window via push-button <SELECT/RESET>.

## 5.9 Additional Functions

### 5.9.1 Blocking of the Protective Functions

#### Blocking of the protective functions

After voltage has been applied to blocking input D8/E8, the intended reaction for each of the protective functions can be defined individually. (Observe voltage adjustment !) See chapter 3.1.4

Setting	Effect when voltage has been applied to the blocking input
PR_B	Complete blocking of the protective element. Activation and trip are suppressed.
TR_B	Blocking of trip elements. The individual protective elements are activated and this is signalled accordingly, but there is no tripping.
BLOC	Complete blocking of the protective element. Activation and tripping are suppressed. This is displayed if it is not differentiated between PR_B and TR_B in a parameter.
NO_B	No blocking. This element operates normal, it is not blocked

Table 5.2: Adjustment Possibilities

Setting of parameters should be done as follows:

- To come to the blocking menu push-buttons <ENTER> and <TRIP> are to be pressed at the same time. The function being set is indicated by LEDs.
- If necessary the blocking function can be changed with <+> or <-> and saved with <ENTER> Perhaps a password has to be entered.
- Proceed to the next function with <SELECT/RESET>
- After selection of the last blocking function settings for the 2nd parameter set can follow.
- For allocating the RESET function press push-button <SELECT/RESET> again. (See next chapter).

Symbol	Protective Function	Default Setting	Possible Settings	LED/Colour
g>	Overload warning element	NO_B	NO_B ; BLOC	g> red
I <sub>B</sub> > x k	Overload element	NO_B	NO_B ; PR_B ; TR_B	I <sub>B</sub> > green/ $\tau_{w}$ green
I<	Undercurrent element	NO_B	NO_B ; PR_B ; TR_B	I< red
I>	Over current element	NO_B	NO_B ; PR_B ; TR_B	I> red
I>> Start	Short-circuit element at start-up	BLOC	NO_B ; PR_B	I>> red/Start green
I>>	Short-circuit element during operation	PR_B	NO_B ; PR_B ; TR_B	I>> red
I2>	Load unbalance element	NO_B	NO_B ; PR_B ; TR_B	I2> red
I <sub>E</sub> >	Earth current element	NO_B	NO_B ; PR_B ; TR_B	I <sub>E</sub> > red
tCBFP	CB failure protection	NO_B	NO_B ; BLOC	CB green
Trip	External trip	NO_B	NO_B ; BLOC	Trip red

Table 5.3: Default Setting of the Blocking Functions



## 5.9.2 Allocation of the Reset Functions

When setting of the parameters for the blocking function is completed you are in the allocation mode for the reset functions. Whether the assigned relay should be reset manually or automatically after activation or trip can be allocated to each of the activation or trip elements. Which of the reset function

- If necessary the reset function can be changed with <+> or <-> and saved with <ENTER> Perhaps a password has to be entered.
- Proceed to the next function with <SELECT/RESET>
- After selection of the last reset function settings for the 2nd parameter set can follow.
- For allocation of the output relays press push-button <SELECT/RESET> again. (See next chapter).

Symbol	Protective Functions	Default Setting	Possible Settings	LED/Colour
9>	Overload warning	AUTO	HAND ; AUTO	9> red
I <sub>B</sub> > x k	Overload alarm	AUTO	HAND ; AUTO	I <sub>B</sub> > green
I <sub>B</sub> > x k	Overload trip	AUTO	HAND ; AUTO	I <sub>B</sub> > green/tw green
I<	Undercurrent alarm	AUTO	HAND ; AUTO	I< red
tI<	Undercurrent trip	AUTO	HAND ; AUTO	I< red/t> red
I>	Over current alarm	AUTO	HAND ; AUTO	I> red
tI>	Over current trip	AUTO	HAND ; AUTO	I> red/t> red
I>> Start	Short-circuit tripping when starting*	AUTO	HAND ; AUTO	I>> rot/t> rot/ Start green
I>> Start	Short-circuit tripping during oper.	AUTO	HAND ; AUTO	I>>red
tI>> Start/op.	Short-circuit tripping during oper.	AUTO	HAND ; AUTO	I>> red/t> red
I <sub>2</sub> >	Load unbalance alarm	AUTO	HAND ; AUTO	I <sub>2</sub> > red
tI <sub>2</sub> >	Load unbalance trip	AUTO	HAND ; AUTO	I <sub>2</sub> > red/t> red
I <sub>E</sub> >	Earth current alarm	AUTO	HAND ; AUTO	I <sub>E</sub> > red
tI <sub>E</sub> >	Earth current trip	AUTO	HAND ; AUTO	I <sub>E</sub> > red/t> red
tCBFP	CB failure protection	AUTO	HAND ; AUTO	CB green
Trip	External trip	AUTO	HAND ; AUTO	Trip red

Table 5.4: Default setting of the Reset Functions

\* Short-circuit excitation during starting always has automatic reset

### 5.9.3 Allocation of the Output Relays

The MRM3-2 has five output relays. The fifth output relay is an alarm relay for the self-supervision and its allocation is fixed; it is operated acc. to the closed circuit principle.

Output relays 1 - 4 can be freely allocated to the current functions either as alarm or trip relay; they are operated acc. to the open circuit principle. Allocation of the output relays is similar to the parameter setting method in the BLOCKING mode or RESET mode. T

The allocation mode is activated with the last actuation of the <SELECT/RESET> push-button in the RESET mode (as explained above).

Each of the protective functions has two states:

#### Alarm

This state is active, as soon as the setting value of the element is exceeded.

#### Trip

This state is active after the time of the trip delay has elapsed.

The adjustment procedure is as follows:

Allocation of one or more of the 4 output relays to "Alarm" or "Trip" of each of the protective functions. Which of the function is just being processed is signaled by the LEDs.

In addition to the protective functions special-purpose signals can be given by the relays:

- Startblock (Start is not recommended)
- START (Motor is starting)
- LAUF (Motor in operation)

Indication	LED	Allocated relay(s)
— — — —		None
1 — — —		1
— 2 — —		2
... — — —		...
— 2 3 4		2, 3 and 4
1 2 3 4		all

By pressing push-buttons <+> and <-> all possible combinations can be realized. The selected allocation can be saved by <ENTER> and subsequent entry of the password.

Any allocation mode can be stopped by pressing the <SELECT/RESET> button for a certain time (about 3s).

#### Note:

- Coding plugs J2 and J3, described in the general description „MR- Digital Multifunctional Relay“ have no function in the MRM3-2.
- At the end of this description an Adjustment List can be found in which the customer-specific adjustments can be filled-in.

Relay functions		Output relays				Displayed figures	Corresponding LED
Symbol	Function	1	2	3	4		
g>	Alarm		X			_ 2 _ _	g> red
l <sub>B</sub> > x k	Alarm		X			_ 2 _ _	l <sub>B</sub> > green
l <sub>B</sub> > x k	Tripping	X				1 _ _ _	l <sub>B</sub> > green/t <sub>w</sub> green
l<	Alarm		X			_ 2 _ _	l< red
tl<	Tripping	X				1 _ _ _	l< red/t> red
l>	Alarm		X			_ 2 _ _	l> red
tl>	Tripping	X				1 _ _ _	l> red/t> red
l>>	Alarm		X			_ 2 _ _	l>>red/Start green
l>> Start	Tripping	X				1 _ _ _	l>> red/t> red/ Start green
l>>	Alarm		X			_ 2 _ _	l>>red
tl>>	Tripping	X				1 _ _ _	l>> red/t> red
l2>	Alarm		X			_ 2 _ _	l2> red
tl2>	Tripping	X				1 _ _ _	l2> red/t> red
l <sub>E</sub> >	Alarm		X			_ 2 _ _	l <sub>E</sub> > red
tl <sub>E</sub> >	Tripping	X				1 _ _ _	l <sub>E</sub> > red/t> red
t <sub>CBFP</sub>	Tripping					_ _ _ _	CB green
Ext. Trip Undelayed	Tripping	X				1 _ _ _	Trip red
Ext. Trip Delayed	Tripping	X				1 _ _ _	Trip red / t> red
Start/Block	Start blocking			X		_ . . 3 . _	Start green/ Block green
Start	Motor starting					_ _ _ _	Start green
Operation	Motor running				X	_ _ _ 4	S/R green
Start time	Excessive starting time	X				1 _ _ _	Start green/t> red
ParaSet 2	Parameter set 2 is active					_ . . . .	P2 yellow

Table 5.5: Example of an Allocation Matrix of the Output Relays (Default Setting)

## 5.10 Measuring Value and Fault Indications

### 5.10.1 Measuring Value Indications

The following measuring values can be displayed during normal operation:

- Current in phase 1 (LED L1 green),
- Current in phase 2 (LED L2 green),
- Current in phase 3 (LED L3 green),
- Earth current (LED E green),
- Load unbalance current (LED I2 green),
- Temperature equivalent  $\vartheta>$  in % (LED  $\vartheta>$  red),
- Operating hours (LED h yellow)
- Number of motor starts (LED No. green)
- Time until tripping in min. (LED Trip/t> red)
- Remaining time of start blocking in min. (LED Start/Block green and t> red)
- Date and time (LED  $\oplus$  green)

### 5.10.2 Units of the Displayed Measuring Values

Indication of the measuring value can be represented in the display optionally as multiple of the secondary rated current ( $x I_n$ ) or as primary current (A). Consequently the units displayed are changing, i.e. for:

#### Phase Current

Indicated as	Range	Unit
Secondary current	.000 – 40.0	$x I_n$
Primary current	.000 – 999.	A
	k000 – k999	kA*
	1k00 – 9k99	kA
	10k0 – 99k0	kA
	100k – 999k	kA
	1M00 – 2M00	MA

\* for rated transformer current starting at 2kA

#### Earth Current

Indicated as	Range	Unit
Secondary current	.000 – 15.0	$x I_n$
Primary earth current	.000 – 999.	A
	k000 – k999	kA*
	1k00 – 9k99	kA
	10k0 – 99k0	kA
	100k – 999k	kA
	1M00 – 2M00	MA

\* for rated transformer current starting at 2kA

### 5.10.3 Indication of the Fault Data

All fault events acquired by the relay are optically indicated on the front cover. For the MRM3-2 the four LEDs (L1, L2, L3, I2; E) and the functional LEDs ( $\vartheta>$ ;  $I_B>$ ;  $I<$ ;  $I>$ ,  $I>>$ ,  $I2>$  and  $I_E>$ ) are provided. Not only fault signals are put out but also the activated protective function is indicated. If, for instance, over current occurs, the LEDs assigned to the respective phases are flashing. LED  $I>$  comes on also at the same time. After elapse of the trip-ping time the flashing LEDs change to permanent light.

## 5.10.4 Fault Memory

In case of actuation or tripping of the relay, the fault values and times are stored in a voltage fail-safe way. The MRM3-2 has a fault value memory covering up to 25 fault events. If this number is exceeded, the eldest data set is then overwritten.

Besides the tripping values, the LED states are also saved for fault indication.

### Inquiry of the fault memory

When the <-> push-button is pressed during normal measuring value indication, the fault data is displayed.

FLT1            last fault  
 FLT2            fault before last  
 etc.

By pressing <+> the respective fault can be selected.

During fault value indication FLT

- it can be changed over to another fault data set by pressing <+> or <->
- it is displayed, which of the parameter sets was active during the event
- the LEDs are flashing according to the stored pick-up values/trip information, i.e. LEDs showing a permanent light when the trip occurred, start to flash in order to indicate that it was a past fault condition. Those LEDs, which were flashing when the trip occurred, (element was actuated) are flashing briefly
- the individual fault measuring values for the respective fault can be inquired by pressing <SELECT/RESET>

If the relay has not been reset after tripping (TRIP is displayed), measuring values cannot be indicated.

The fault memory can be cleared by pressing the button combination <SELECT/RESET> and <-> for about 3s. In the display „wait“ is shown.

### Trigger signal for the fault memory

There are three trigger signals for the fault recorder

1. End of a starting phase,
2. A tripping signal,
3. End of a protection excitation in OPERATING mode

depending on which event has occurred, the following values are recorded.

#### 1. Values recorded at the end of a starting phase

- max. starting current in Phase 1,
- max. starting current in Phase 2,
- max. starting current in Phase 3,
- Earth current E,
- Load-unbalance current I<sub>2</sub>,
- Temperature equivalent  $\vartheta$  in % at this time,
- Change in the temperature equivalent  $\vartheta$  in % during the starting phase
- Duration of start in s,
- Date and time.

#### 2. Values recorded after an excitation

- Peak current during this excitation in Phase 1,
- Peak current during this excitation in Phase 2,
- Peak current during this excitation in Phase 3,
- Peak current during this excitation in the earth current path
- Peak current during this excitation for load unbalance
- Temperature equivalent  $\vartheta$  in % at this time,
- Date and time.

### 3. Values recorded after a tripping action

- Tripping current in Phase 1,
- Tripping current in Phase 2,
- Tripping current in Phase 3,
- Tripping value for earth current E,
- Tripping value for load-unbalance current I2,
- Tripping value for the temperature equivalent  $\vartheta$  in %,
- Switch failure time,
- Date and time.

## 5.11 Reset

The MRM3-2 offers the following three ways to reset the displayed indications as well as the output relay.

- Manual reset  
By pressing the <SELECT/RESET> push-button for some time (about 3 seconds)
- External reset  
By applying aux. voltage to C8/D8
- Reset via interface  
By transmitting the RESET command from the Master PC.  
An indication can only be reset if there is no protective function activated. (Otherwise "TRIP" remains in the display). The set parameters are not changed by the reset procedure.

### 5.11.1 Erasure of the Fault Memory

For erasure of the fault memory the push-button combination <SELECT/RESET> and <-> has to be pressed for about 3 s. During the erasure procedure „wait“ is displayed.

### 5.11.2 Reset of the Thermal Memory

It is possible to erase the thermal memory  $\vartheta$  to 0%. By pressing the push-button combination <SELECT/RESET> and <+> for some time (about 3 s) the thermal memory is reset to 0%.

#### **IMPORTANT:**

This function has to be used with extreme care. During secondary tests it can be very useful to have always constant start conditions. If, however, after overload tripping the thermal image is reset in order to restart the motor as quickly as possible, then there is the risk of overloading the motor because it is still hot but the protective unit proceeds on the assumption that the motor is cold.

## 5.12 Digital Inputs

### 5.12.1 Parameter Set Changeover Switch

When voltage is applied to this input it is changed over to the other parameter set.

### 5.12.2 External Trigger of the Fault Recorder

Via this input fault recording can be triggered without the MRM3-2 necessarily recognizing a trip.

### 5.12.3 Recognition of “Motor Running” Condition

This input can be used if the motor runs without load and does not need much current ( $I < 2\% \times I_N$ ). In such a case the motor current may lie below the STOP threshold and so recognition of the RUNNING conditions is not secure. In order to maintain the RUNNING conditions, voltage can be applied to this input by means of an aux. contact of the CB. This is necessary so that all functions which depend on the RUNNING conditions can operate faultless (e.g.  $I >>$  LAUF,  $I >$ , start counter etc.) and the LEDs are signaling the correct motor status. In such a case the under load element must not be used. ( $I <$  must be set to EXIT)

### 5.12.4 Undelayed External Trip

A trip is immediately triggered if voltage is detected by this input. The fault recorder is activated and the assigned output relay picks up.

### 5.12.5 Delayed External Trip

In principle this input has the same effect as the input for undelayed trip, but a trip is only triggered if the input signal was available during the entire adjusted delay time.

## 6. Notes on Relay Tests and Commissioning

### 6.1 Connection of the auxiliary voltage

To prevent destruction of the relay during tests the following has to be observed:

- The aux. voltage supply of the relay must be within the permissible ranges.
- The test current must not exceed the thermal rating of the measuring circuits.
- The CTs must be connected properly.
- All control and measuring circuits as well as the output relays must be connected properly.
- The voltage ranges of the digital inputs must be adjusted correctly.

For further information please see Technical Data

### 6.2 Testing of Output Relays and LEDs

Checking of the output relays and of all LEDs can be triggered by the <TRIP>-push-button.

#### Test procedure

Entry	Display	Note
<TRIP>	DO1	Display of the relay software version (part 1)*
<TRIP>	1.00	Display of the relay software version (part 2)*
<TRIP>	PSW ?	Call for enter the password
PSW?	**** TRI ?	Password entry Ready for tests
<TRIP>	TRIP	Start the test Release of self-test relay Pick-up of all output relays Test of all LEDs
<Select/ Reset>	WW	Finish the test, Output relays return to their current operational state

\* If possible please state when writing to us.

#### Careful when the relay is installed:

The relay test is not a pure internal test. All the output re-lays will be energized! After starting test the self-supervision relay releases first. Hereby a relay fault could be adopted by a connected control gear.

Thereafter all other existing output relays will pick up one after another. The reaction in the relevant switchboard could be accordingly (e.g. trip of a priority CB).



## 6.3 Test circuit for MRM3-2

For testing the MRM3-2 relays only one power source is necessary. Figure 6.1 shows a simple example of a single-phase testing circuitry with controllable power source for testing the unit.

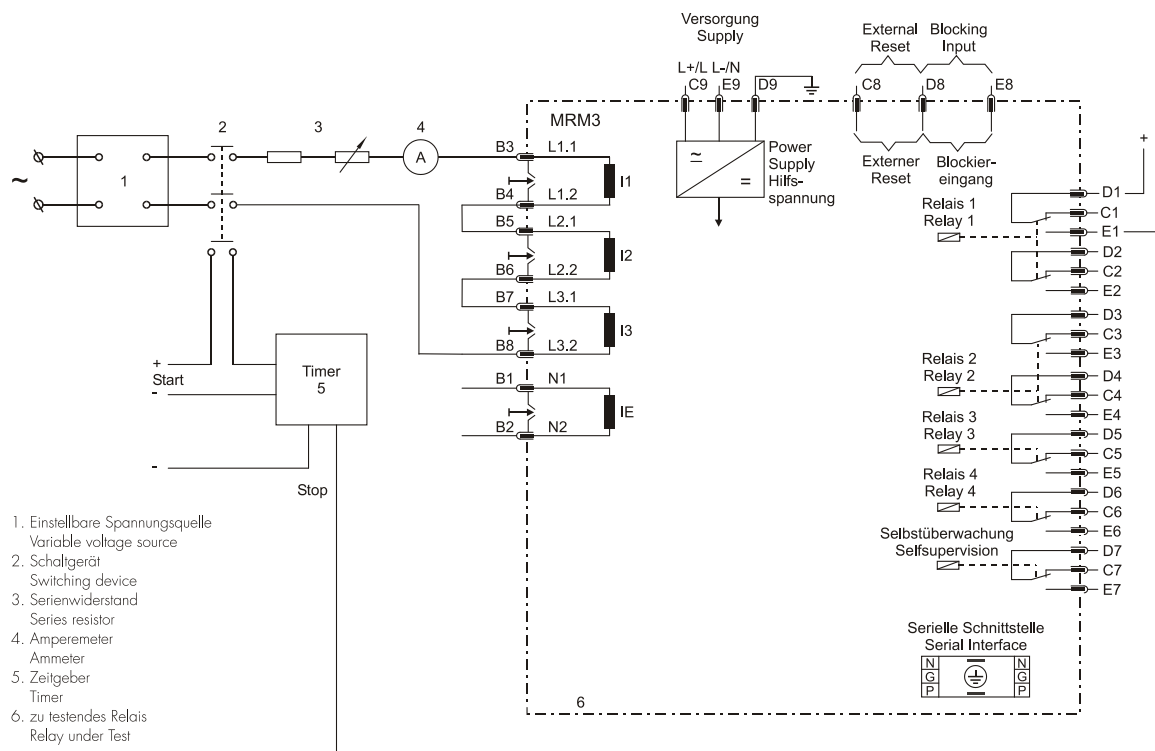

Figure 6.1: Test circuit

### 6.3.1 Checking of Input Circuits and of the Measuring Values

#### Single-phase conductor current test

The test can be carried out with a single phase. For this procedure all three phase current measuring inputs have to be connected in series. Restriction : For single-phase testing the load unbalance element has to be deactivated because it cannot be tested with three equal-phase currents.

#### Three-phase conductor current test

For this test a relevant three-phase test source (120° phase shift !) must be available. Each channel of the source is connected with one conductor current input. This test circuitry is recommended because with this most of the tests can be carried out. For testing the earth fault channel a single-phase test should then follow.

For tests in Holmgreen connection, simulation of an earth fault current has to be considered. Conductor currents have to be fed by the source the geometrical total of which has to be in accordance with the required earth fault current. But such asymmetry of the conductor currents can cause the load unbalance element to trip (dependent on its setting).

### 6.3.2 Testing the START-STOP-RUNNING Recognition

In a secondary test this elementary function can only be reliably tested if the test source can generate the exact chronological course of a starting current. If ever possible this should be carried out as primary test. Under all normal start conditions, the status indications should be signaled correctly. Please bear in mind: the STOP condition is only signaled after the STOP time has elapsed and RUNNING is only indicated after elapse of the start recognition time the earliest. Dependent on the actual kind of start or on the spectrum of possible varying starting conditions, modification of both parameters might be necessary.

### 6.3.3 Testing the Pick-Up and Disengaging Values

For optimal protection many functions in this motor protection relay are interlinked and hence it is not possible to have all protective elements tested independently from each other.

For all functions linked with the START/STOP/RUNNING recognition, a start simulation has to be performed so that the function can be tested under real conditions. Some of the tests could be simplified if special parameters would be set, but in most of the cases this is not wanted.

Hence for testing the short-circuit element I $\gg$ RUNNING, for instance, the MRM3-2 has to recognise the simulated running condition firstly. The test source must be able to copy the course of the motor current exactly as it is in reality. The required test short-circuit current can only be injected after the MRM3-2 has recognized the running condition. The test conditions of the other elements, i.e.:

I $\gt$   
I $\lt$   
I $\gg$  Start  
I $\gg$  RUNNING

have to be adjusted according to the application of the selected parameters.

### 6.3.4 Testing the maximum starting time

The timer for maximum starting time starts running if the impressed current exceeds the overload threshold of  $k \cdot I_B$  immediately after exceeding the starting threshold and within the start recognition time. There will be trip-ping if the threshold  $k \cdot I_B$  is not underscored again after the set time has expired. There are two possibilities of adjustment. If the tripping characteristic for the max. starting time is set to "DEFT" (Definite Time), tripping takes place after the set time has expired. If the parameter is set to "INVS" (Inverse Time Characteristic), the tripping time is dependent on the set rated starting current and a time multiplier. The multiplier is set with the same parameter as in case of the maximum starting time with defined tripping time. The maximum tripping time is limited to 2 x standard time. The minimum tripping time is limited to the shortest possible tripping time of the MRM3-2.

### 6.3.5 Testing the thermal image

For the thermal image there is no start simulation required. But for true propositions it is important that each start proceeds from distinct start conditions. The thermal behavior of the motor is taken into account in the thermal image. This means that the time for simulated cooling down and for the store to be back to zero after a test can be accordingly. (The store can also be reset manually). As general rule applies that at constant current 99 % of the thermal processes have reached their final value after 5 times the time constant (warming up or cooling down).

### 6.3.6 Testing the Control Inputs

Prior to the test it should be ensured that the voltage ranges of the inputs (jumper) are correctly adjusted (see chapter 3.1.4).

### 6.3.7 Testing the CB Failure Protection

For this test the test source must be able to simulate a circuit breaker and switch-off the current after a selectable time when the MRM3-2 was triggered (see chapter 5.4.18). To meet these requirements, the test source must have a respective signal input and a timer for switching-off the current.

## 6.4 Primary Test

As a rule, tests with currents at the CT primary side (real test) can be performed in the same way as tests with secondary currents. It is recommended to carry out primary tests only as an exception and only if it is absolutely necessary (for very essential protective facilities) because in some cases the costs involved and the strain on the system can be rather high. Many functions of the MRM3-2 can be checked during normal operation of the system due to the efficient fault and measuring value indications. So it is possible, for example, to compare the currents shown on the display with the values shown on the ammeters in the switchboard.

## 6.5 Maintenance

Normally the relays are checked at regular maintenance intervals at site. From user to user these intervals may vary because among other things they depend on the type of relay, the kind of application, significance of the object to be protected, previous experience of the user etc. For electro-mechanical or static relays normally an annual check is required. For the MRM3-2 the maintenance intervals can be much longer because:

- the MRM3-2 relays are provided with wide-ranging self-test functions and consequently relay faults are detected and indicated. It is, of course, imperative that the internal self-supervision relay is connected to a central display board.
- The combined measuring functions of the MRM3-2 make monitoring during operation possible.
- The trip test function (TRIP-Test) allows testing of the output relays.

Therefore a maintenance interval of two years is sufficient. When servicing all relay functions incl. setting values, trip characteristics and tripping times ought to be thoroughly checked.

## 7. Technical Data

### 7.1 Measuring input

Rated data:	Rated current $I_N$	1A or 5A
	Rated frequency $f_N$	50/60 Hz adjustable
Power consumption in current path:	at $I_N = 1\text{ A}$	0.2 VA
	at $I_N = 5\text{ A}$	0.1 VA
Thermal withstand capability Of the current paths:	Current surge (on half-wave)	250 x $I_N$
	for 1 s	100 x $I_N$
	for 10 s	30 x $I_N$
	continuously	4 x $I_N$
Fault recorder		
Recorded tracks:	$i_{L1}, i_{L2}, i_{L3}, i_E$	
Sampling rate:	1.25 ms at 50 Hz	
	1.041 ms at 60 Hz	
Storage capacity:	16 s (at 50 Hz) resp.	
	13.33 s (at 60 Hz)	
Number of events:	1-8	

### 7.2 Common data

Dropout to pickup ratio:	>97%
Returning time: 40 ms	
Time lag error class index E:	$\pm 20\text{ ms}$
Minimum operating time:	40 ms
Transient overreach at instantaneous operation:	$\leq 5\%$
Permissible interruption of the supply voltage without affecting the relay function:	50 ms
Influences on the current measurements	
Auxiliary voltage:	in the range of $0.8 < U_H / U_{HN} < 1,2$ No additional influences can be measured
Frequency:	in the range of $0.9 < f / f_N < 1.1$ ; $< 0.2\%$
Measuring errors at higher frequencies: 70Hz – 400Hz	$< 0.2\% / \text{Hz}$
Influences on delay time:	no additional influences can be measured

For further technical data see the general description „MR-Multifunctional Relay“.

## 7.3 Setting ranges and steps

### 7.3.1 System parameter

\*) One parameter can be marked by several LEDs

Parameter	LED *	Setting range		Range	Step	Tolerance
Transformer ratio phase current $I_{prim}$	L1 L2 L3	SEK 0.002... 50.0 kA	Displayed in x $I_N$ Displayed in kA	0.002-0.200 0.200-0.500 0.500-1.00 1.00-2.00 2.00-5.00 5.00-10.0 10.0-20.0 20.0-50.0	0.001; 0.002; 0.005; 0.01; 0.02; 0.05; 0.1; 0.2	
Transformer ratio earth current $I_{prim E}$	E	SEK 0.002... 50.0 kA	Displayed in x $I_N$ Displayed in kA	0.002-0.200 0.200-0.500 0.500-1.00 1.00-2.00 2.00-5.00 5.00-10.0 10.0-20.0 20.0-50.0	0.001; 0.002; 0.005; 0.01; 0.02; 0.05; 0.1; 0.2	
Operating hour meter	h	Y=00...28	years		1 year	
	h	0000... 8759	hours		1 hour	
Motor starts	No	0000... 9999	Number of starts		1	
Rated frequency	-	f=50 f=60	Hz			
LED flashing af- ter activation	-	NOFL FLSH	no yes			
Date and time	⊕	Y=00... 99 M=01...12 D=01... 31* h=00... 23 m=00...59 s=00... 59	Year Month Day (*depends on month) Hour Minute Second		1 year 1 month 1 day 1 hour 1 minute 1 second	
Parameter set changeover switch	P2	SET1 SET2	active parameter set			

### 7.3.2 Time over current protection

Parameter	LED	Setting range	Notes	Range	Step	Tolerance
Therm. Permissible contin. current $k \times I_B$	$I_B$	0.20...4.00 EXIT	$x I_N$ Step switched off		0.01; 0.02; 0.05; $0.1 \times I_N$	$\pm 3\%$ of setting value or $\pm 10\text{mA}$
Overload factor	k	0.80...1.20			0.01	
As warning or tripping step	$I_B > +\tau_W$	warn trip	Step signals warning Step signals tripping			
Excitation delay for $I_B > *k$	$I_B > +t >$	0,1...260		0.04-1.00 1.00-2.00 2.00-5.00 5.00-8.00 8.00-10.0 10.0-20.0 20.0-50.0 50.0-100 100-200 200-260	0.02 0.05 0.1 0.2 0.5 1.0 2.0 5.0 10.0 20.0	$\pm 3\%$ of setting value or $\pm 25\text{ms}$
Heating time constant	$\tau_W$	0.5...180	min	0.5-2.0 2.0-5.0 5.0-10 10-20 20-50 50-100 100-180	0.1 0.2 0.5 1.0 2.0 5.0 10.	$\pm 3\%$ referring to current measuring value or $\pm 30\text{ms}$ (See EN 60255-3)
Time limit	$\tau_W$ Start	t2x t6x EXIT	ab $2 \times k * I_B$ ab $6 \times k * I_B$ no limitation			
Cooling down factor	$\tau_C$	1.00...8.00	$x \tau_W$	1.00-2.00 2.00-5.00 5.00-8.00	0.05 0.1 0.2	$\pm 3\%$ referring to measuring value or $\pm 30\text{ms}$ (See EN 60255-3)
Warn step ther. image	$\vartheta >$	20...99 EXIT	Warning at % $\vartheta >$ Step switched off	20-99	1	$\pm 1\%$ of the setting value
Undercurrent	$I <$	0.10...1.00 EXIT	Trip delay $x I_N$ Step switched off	0.100-0.200 0.200-0.500 0.500-1.00	0.005 0.01 0.02	$\pm 3\%$ of the setting value or $\pm 10\text{mA}$
	$I < +t >$	0,1...260 EXIT	Trip delay in s Warning only	0.04-1.00 1.00-2.00 2.00-5.00 5.00-8.00 8.00-10,0 10.0-20,0 20.0-50,0 50.0-100 100-200 200-260	0.02 0.05 0.1 0.2 0.5 1.0 2.0 5.0 10.0 20.0	$\pm 3\%$ of the setting value or $\pm 25\text{ms}$
Over current	$I >$	0.2...4.0 EXIT	Pick-up value $x I_N$ Step switched off	0.20-0.50 0.50-1.00 1.00-2.00 2.00-4.00	0.01 0.02 0.05 0.1	$\pm 3\%$ of the setting value or $\pm 10\text{mA}$
Characteristics	$I > +\text{CHAR}$	DEFT NINV	definite normal inverse			

Parameter	LED	Setting range	Notes	Range	Step	Tolerance
		VINV EINV RINV LINV	very inverse extremely in- verse RI-inverse Long-term in- verse			
Time delay	I>+t>	at DEFT: 0.04 ...260	Time delay in s	0.04-1.00 1.00-2.00 2.00-5.00 5.00-8.00 8.00-10.0 10.0-20.0 20.0-50.0 50.0-100 100-200 200-260	0.02 0.05 0.1 0.2 0.5 1.0 2.0 5.0 10.0 20.0	±3% of the set- ting value or ±25ms
		at _INV: 0.05 - 20  EXIT	Characteristic parameter  Warning only	0,05-0,50 0,50-1,00 1,00-2,00 2,00-5,00 5,00-10,0 10,0-20,0	0,01 0,02 0,05 0,1 0,2 0,5	±3% related to the measured current value or ±30ms (See EN 60255- 3)
Short-circuit step at start	I>> Start	0.5...40  EXIT	Pick-up value x $I_N$ during Start Step switched off	0.50-1.00 1.00-2.00 2.00-4.00 4.00-10.0 10.0-20.0 20.0-40.0	0.02 0.05 0.1 0.2 0.5 1.0	±3% of the set- ting value or ±10mA
Time delay	I>> Start+t >	0.04...10 EXIT	Tripping delay in s warning only	0.04-1.00 1.00-2.00 2.00-5.00 5.00-10.0	0.02 0.05 0.1 0.2	±3% of the set- ting value or ±25ms
Running	I>>	0.5...40  EXIT	Pick-up value x $I_N$ During running Step switched off	0.50-1.00 1.00-2.00 2.00-4.00 4.00-10.0 10.0-20.0 20.0-40.0	0.02 0.05 0.1 0.2 0.5 1.0	±3% of the set- ting value or ±10mA
Trip delay	I>>+t>	0.04...10 EXIT	Trip delay in s Warning only	0.04-1.00 1.00-2.00 2.00-5.00 5.00-10.0	0.02 0.05 0.1 0.2	±3% of the set- ting value or ±25ms

### 7.3.3 Load Unbalance Protection

Parameter	LED	Setting range	Notes	Range	Step	Tolerance
Load unbalance	I2>	0,02...1,00 EXIT	Pick-up value negative phase sequence system - displayed in $x I_N$ - Step switched off	0.020 0.050 0.050 - 0.100 0.100 - 0.200 0.200 - 0.500 0.500 - 1.00	0.001 0.002 0.005 0.01 0.02	$\pm 3\%$ of setting value or $\pm 10\text{mA}$
Characteristics	I2>+CHAR	DEFT INVS	definite DMT inverse IDMT			$\pm 3\%$ in relation to the measured current value or $\pm 30\text{ms}$ (see EN 60255-3)
Time delay/ characteristic parameter	I2+t>	At DEFT: 1.00 ...600	Trip delay in s	1.0-5.0 5.0-10.0 10.0-20.0 20.0-50.0 50.0-100 100-200 200-600	0.1 0.2 0.5 1.0 2.0 5.0 10.0	$\pm 3\%$ of the setting value or $\pm 25\text{ms}$
		at INVS: 10.0 - 5000  EXIT	Characteristic parameter  Warning only	10.0-20.0 20.0-50.0 50.0-100 100-200 200-500 500-1000 1000-2000 2000-5000	0.5 1.0 2.0 5.0 10 20 50 100	$\pm 3\%$ referring to current measuring value or $\pm 30\text{ms}$ (See EN 60255-3)



### 7.3.4 Earth fault protection

Parameter	LED	Setting range	Notes	Range	Step	Tolerance
Earth fault protection	I <sub>E&gt;</sub>	0,01...2,0 EXIT	pickup value x I <sub>N</sub> element blocked	0.010 - 0.050 0.050 - 0.100 0.100 - 0.200 0.200 - 0.500 0.500 - 1.00 1.00 - 2.00	0.001 0.002 0.005 0.01 0.02 0.05	±3% of the setting value or ±0.5% of the rated value
As warning or tripping step	I <sub>B&gt;</sub> +τ <sub>w</sub>	warn trip	Step signals warning Step signals tripping			
Characteristics	I <sub>E</sub> +CHAR	DEFT NINV VINV EINV RINV LINV RXIDG	definite normal inverse very inverse extremely inverse RI-inverse Long-term inverse Special characteristic			
Time delay	I <sub>E&gt;</sub> +t <sub>&gt;</sub>	at DEFT: 0.04 ...260	Trip delay in s	0.04-1.00 1.00-2.00 2.00-5.00 5.00-8.00 8.00-10.0 10.0-20.0 20.0-50.0 50.0-100 100-200 200-260	0.02 0.05 0.1 0.2 0.5 1.0 2.0 5.0 10.0 20.0	±3% of the setting value or ±25ms
Characteristics parameter		at _INV: 0.05 - 20  EXIT	Characteristic parameter  Warning only	0.05-0.50 0.50-1.00 1.00-2.00 2.00-5.00 5.00-10.0 10.0-20.0	0.01 0.02 0.05 0.1 0.2 0.5	±3% referring to current measuring value or ±30ms (See EN 60255-3)

Table 7.1: Setting ranges and steps

### 7.3.5 Circuit breaker failure protection

Parameter	LED	Setting range	Notes	Range	Step	Tolerance
	CB+t>	0.1...2.00 EXIT	CB time Step switched off	0.10-1.00 1.00-2.00	0.02 0.05	

### 7.3.6 External trip delay

Parameter	LED	Setting range	Notes	Range	Step	Tolerance
	Trip+t>	0,1...260 EXIT	Switching delay in s No trip	0.04-1.00 1.00-2.00 2.00-5.00 5.00-8.00 8.00-10.0 10.0-20.0 20.0-50.0 50.0-100 100-200 200-260	0.02 0.05 0.1 0.2 0.5 1.0 2.0 5.0 10.0 20.0	±3% of the setting value or ±25ms

### 7.3.7 Trip blocking beginning with the adjusted rated current

Parameter	LED	Setting range	Notes	Range	Step	Tolerance
	Trip+Block	0.5...40 EXIT	Trip blocking from threshold value ( $\times I_N$ ) Function is switched off	0.50 - 1.00 1.00 - 2.00 2.00 - 4.00 4.00 - 10.0 10.0 - 20.0 20.0 - 40.0	0.02 0.05 0.1 0.2 0.5 1.0	±3% of the setting value or ±10mA

## 7.3.8 Start parameter

Parameter	LED *	Setting range	Notes	Range	Step	Tolerance
Start blocking	Start+No	AUTO*  1.0... 60.0  EXIT	Supervision by thermal reserve  Supervision by interval time: Duration of the start period (min)  No supervision	1 - 60	1,0	±2s for one start cycle
*faded out in AUTO	No.	1...20	Permitted starts per period		1	
*faded out in AUTO	Start+Block+t>	VARI 1.0...60	Remaining interval time  Fixed start blocking time min.	1 - 60	1,0	±3% of the setting value or ±25ms
Starting time	Start + CHAR	DEFT INVS	Independent time			±3% in relation to the measured current value or ±30ms (see EN 60255-3)
Rated starting current	I <sub>B</sub> > +Start	0.5...40  EXIT	Start current at rated voltage (x I <sub>N</sub> ) Function switched off	0.50 - 1.00 1.00 - 2.00 2.00 - 4.00 4.00 - 10.0 10.0 - 20.0 20.0 - 40.0	0.02 0.05 0.1 0.2 0.5 1.0	±3% of the setting value or ±10mA
Max./Rated starting time of the engine	Start+t>	0.02...500 EXIT	Tripping delay s Step switched off	0.20 - 1.00 1.00 - 2.00 2.00 - 5.00 5.00 - 10.0 10.0 - 20.0 20.0 - 50.0 50.0 - 100 100 - 200 200 - 500	0.02 0.05 0.1 0.2 0.5 1.0 2.0 5.0 10.0	±3% of the setting value or ±25ms
max starting time (Protective function against prolonged start procedure)	I>+0+t>	0.02...500 EXIT	Trip delay s Step switched off	0.20 - 1.00 1.00 - 2.00 2.00 - 5.00 5.00 - 10.0 10.0 - 20.0 20.0 - 50.0 50.0 - 100 100 - 200 200 - 500	0.02 0.05 0.1 0.2 0.5 1.0 2.0 5.0 10.0	±3% of the setting value or ±25ms
Stopping time STOP recognition	I<+0+t>	0.05...10.0	Time until STOP is recognised s	0.50 - 1.00 1.00 - 2.00 2.00 - 5.00 5.00 - 10.0	0.02 0.05 0.1 0.2	±3% of the setting value or ±25ms

### 7.3.9 Interface parameter

Parameter	LED *	Setting range	Notes	Step	Tolerance
	RS	1 - 32	Slave-Address		
	RS	2400 4800 9600	Baud-Rate * * */**		
	RS	even odd no	Parity even*/** odd* none*		

\* selectable when Modbus Protocol is used

\*\* fixed setting for RS485

### 7.3.10 Fault recorder parameter

Parameter	LED	Setting range	Notes	Range	Step	Tolerance
Number of recordings*	FR	1 3 7  2 4 8	Existing recordings to be overwritten* 1 x 8 s (6.66s) 3 x 4 s (3.33s) 7 x 2 s (1.66s)  Existing recordings not to be overwritten* 2 x 8 s (6.66s) 4 x 4 s (3.33s) 8 x 2 s (1.66s)			
Trigger event	FR	P_UP TRIP A_PI TEST	At actuation At trip After actuation Test recording with button <+> and <->			
Pre-trigger time	FR	0,05...8,00	Duration of the previous event S	0.05-8.00	0.05	

\* All given times refer to 50 Hz (60 Hz in brackets)

## 7.4 Tripping characteristics

### 7.4.1 Tripping characteristic for max. starting time

The formula for calculating the tripping characteristic is:

Inverse Time Characteristic

$$t_{aus} = \frac{1}{\left(\frac{I}{I_{start}}\right)^2} \cdot t_s \text{ this applies if } I/I_{start} > 0,707$$

$$t_{aus} = 2 \times t_s \text{ this applies if } I/I_{start} < 0,707$$

With:

$t_{aus}$  = tripping time

$t_s$  = starting time at rated starting current (rated voltage) or rated starting time

$I$  = effective current

$I_{start}$  = setting value of rated starting current

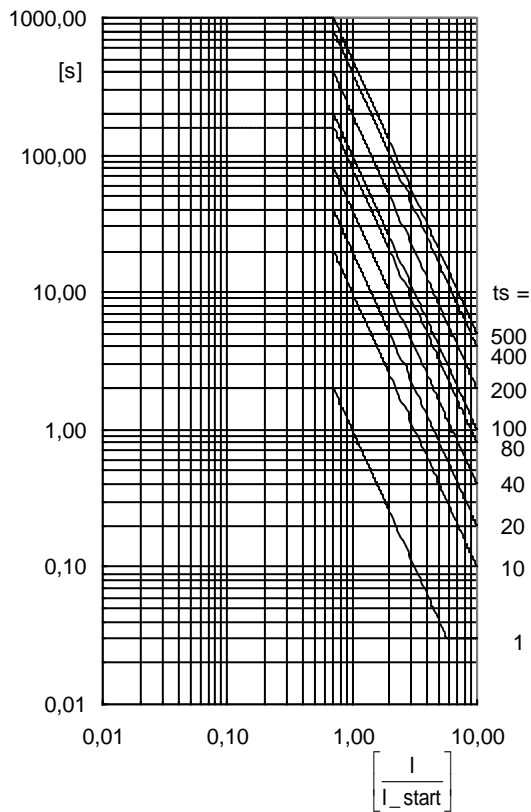

Figure 7.1: Tripping characteristic for max. starting time

### 7.4.2 Thermal image

The formula for calculating the trip characteristics is as follows:

$$t_{aus} = \tau \cdot \ln \left[ \frac{\left( \frac{I^2}{(I_B \cdot k)^2} - p^2 \right)}{\left( \frac{I^2}{(I_B \cdot k)^2} - 1 \right)} \right] \text{ for } p^2 < \frac{I^2}{(I_B \cdot k)^2} \cap p^2 \leq 1$$

- with  $\tau$  = thermal time constant of the object to be protected
- $I$  = Relay current (highest measuring value)
- $I_B$  = Basic current
- $I_P$  = Initial load current
- $p$  = Initial load factor ( $p = 0$  means cold operating component)
- $k$  = Constant

### 7.4.3 Initial load factor

Presentation of the trip with variable initial load factor:

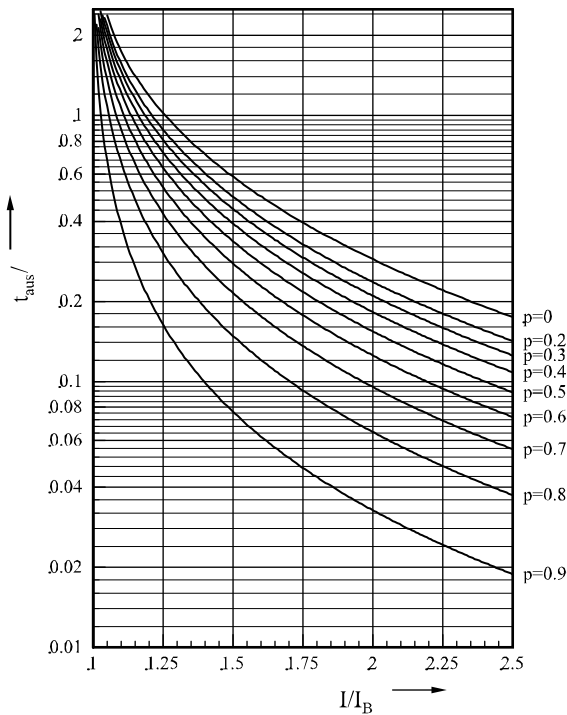

Figure 7.2: Trip Characteristics for Various Initial Load Factors  $p$

### 7.4.4 Tripping of t2x and t6x - times

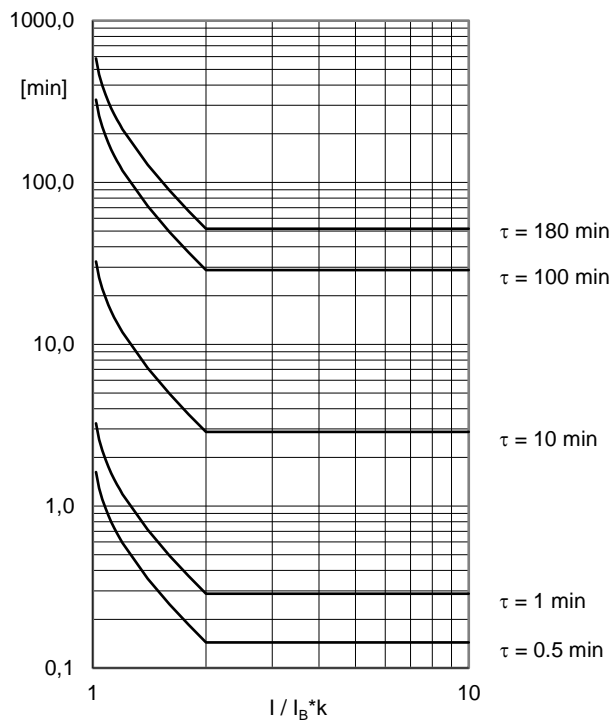

Figure 7.3: Limitation of tripping time  $2 \times I_N$

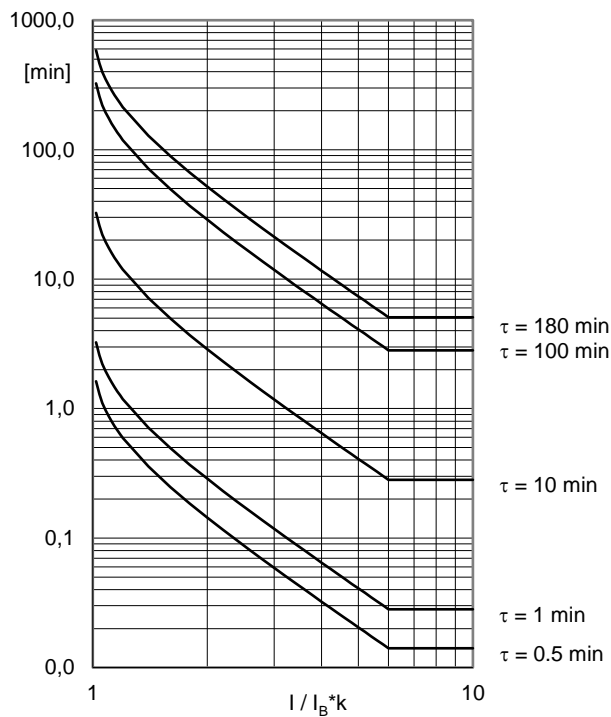

Figure 7.4: Limitation of tripping time  $6 \times I_N$

## 7.4.5 Inverse time over current protection

Trip characteristics acc. to IEC 255-4 or BS 142

Normal inverse (Type A)

$$t = \frac{0.14}{\left(\frac{I}{I_s}\right)^{0.02} - 1} \cdot t_{I>} [s]$$

Very inverse (Type B)

$$t = \frac{13.5}{\left(\frac{I}{I_s}\right) - 1} \cdot t_{I>} [s]$$

Extremely inverse (Type C)

$$t = \frac{80}{\left(\frac{I}{I_s}\right)^2 - 1} \cdot t_{I>} [s]$$

Long time inverse

$$t = \frac{120}{\left(\frac{I}{I_s \times I_{>}}\right) - 1} \cdot a [s]$$

RI-inverse

$$t = \frac{1}{0.339 - \frac{0.236}{\left(\frac{I}{I_s}\right)}} \cdot t_{I>} [s]$$

RXIDG – characteristics

$$t = \left(5.8 - 1.35 \cdot \ln\left(\frac{I}{I_s}\right)\right) \cdot t_{I>} [s]$$

Where:

t	=	Tripping time
t <sub>I&gt;</sub>	=	Time multiplier
I	=	Fault current
I <sub>s</sub>	=	Setting value of the current = natural logarithm



### 7.4.6 Trip characteristics

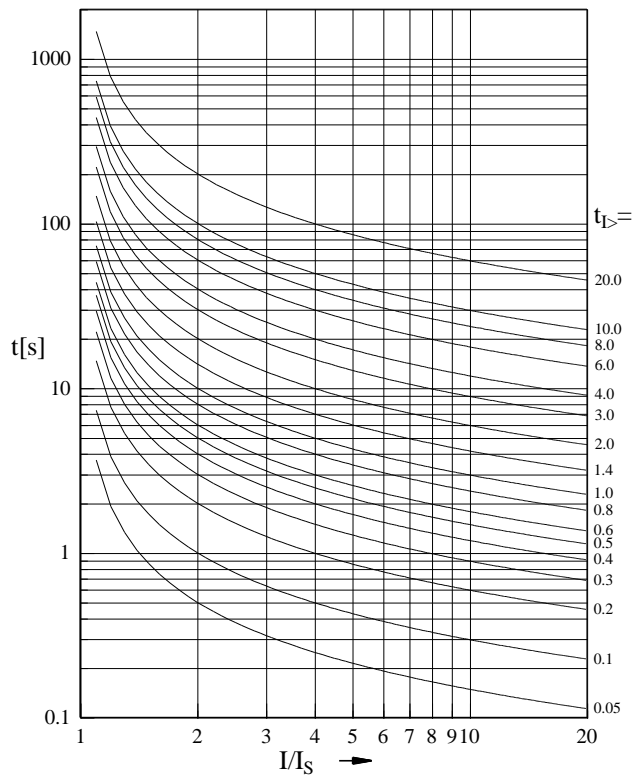

Figure 7.5: Normal Inverse (Type A)

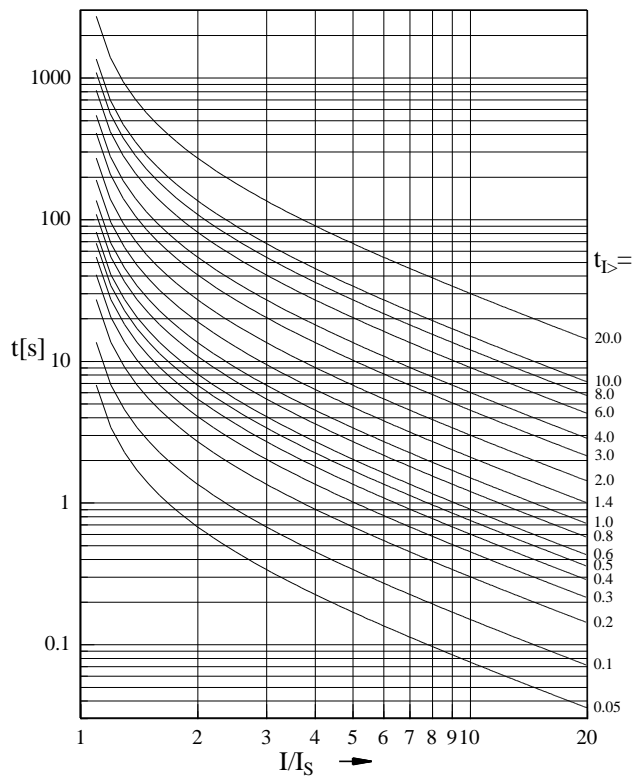

Figure 7.6: Very Inverse (Type B)

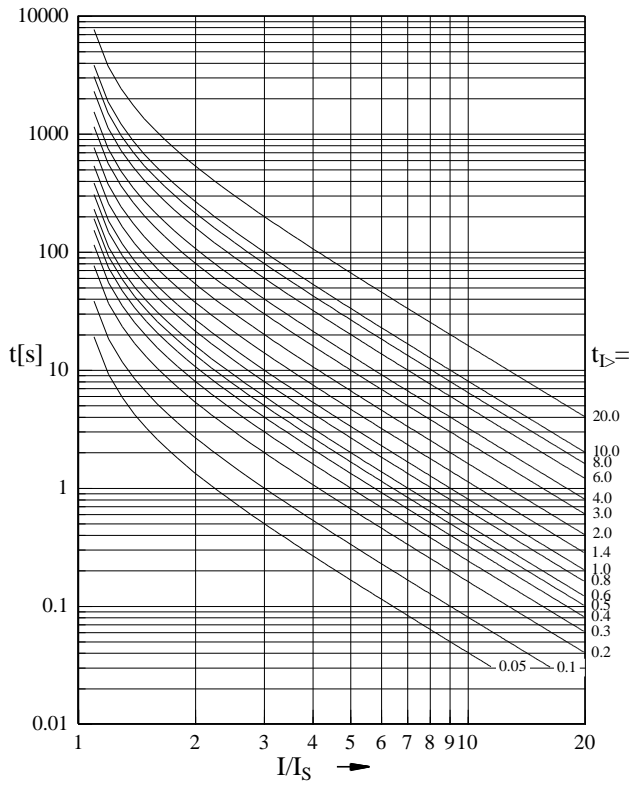

Figure 7.7: Extremely inverse (Type C)

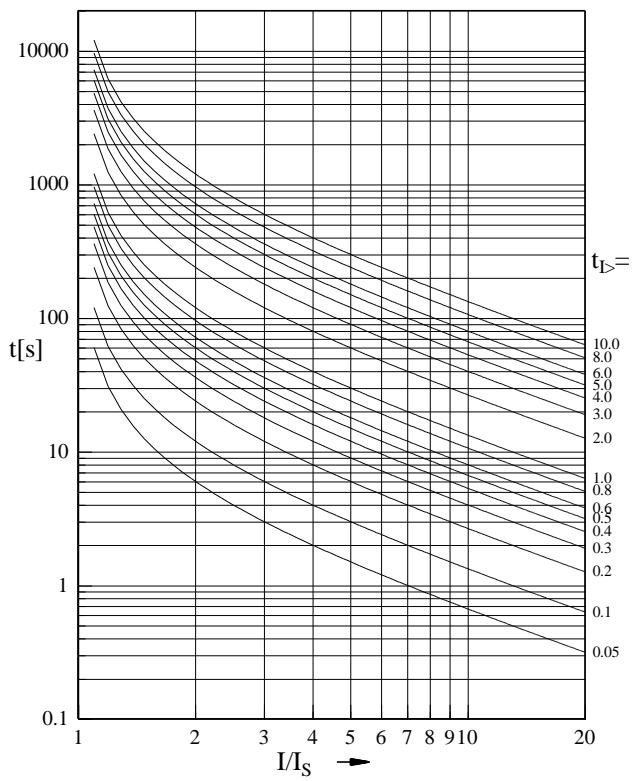

Figure 7.8: Long time inverse

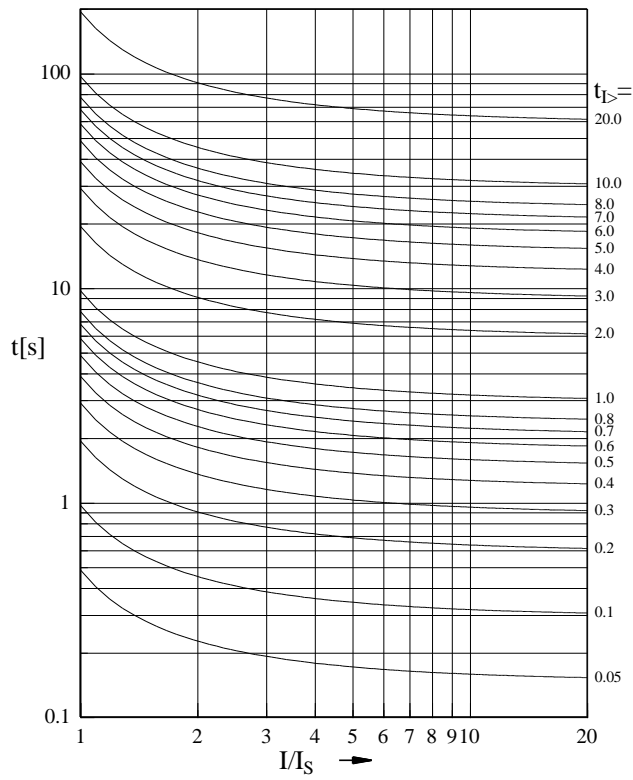

Figure 7.9: RI-inverse

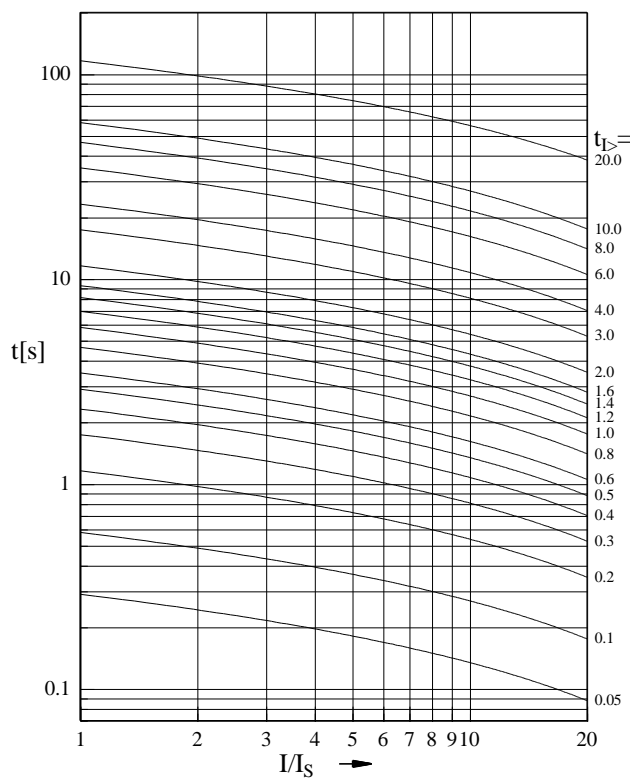

Figure 7.10: RXIDG-characteristic

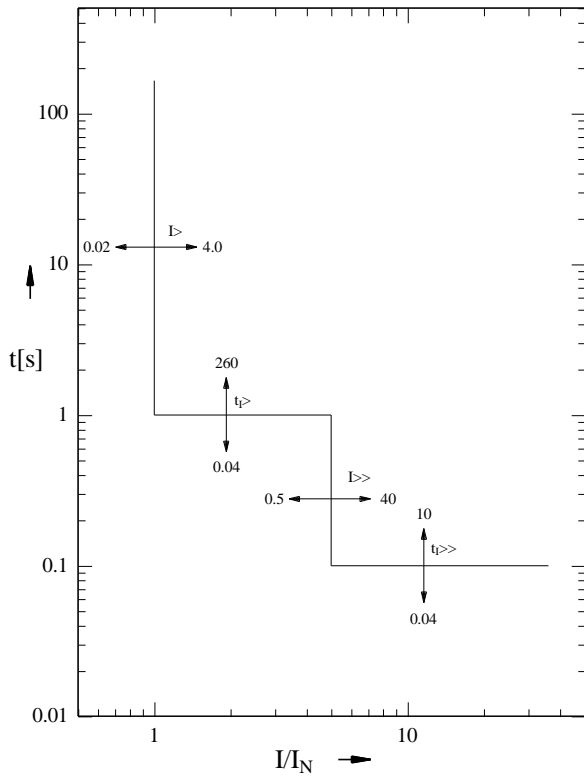

Figure 7.11: Definite trip characteristic

## 7.4.7 Inverse Time Characteristic for Load Unbalance

Inverse current time protection

$$t = \frac{T}{(I_2/I_{2S})^2 - 1}$$

With:  $t$  = tripping time [s]

$T$  = thermal time constant

$I_2$  = measured load unbalance in relation to  $I_N$

$I_{2S}$  = permanently permissible load unbalance in relation to  $I_N$

Tripping characteristic

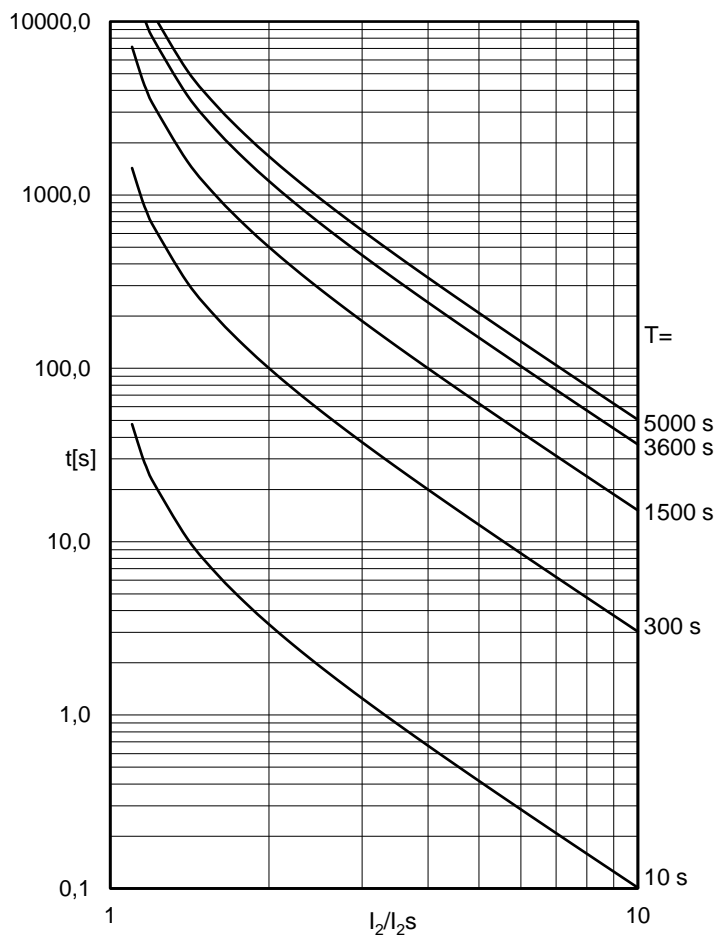

Figure 7.12: Tripping characteristic

## 7.5 Output relays

Contacts: 2 change-over contacts for relays 1 and 2; 1 change-over contact for relays 3 - 4

This information is subject to technical alterations!!

## 8. Order form

<b>Motor protection relay with thermal image</b>		<i>MRM3-</i>	2	I			
With additional features such as characteristic for maximum starting time, tripping delay of the thermal overload, tripping/warning for thermal overload							
Phase current	1 A	rated current		I1			
	5 A			I5			
Earth fault current	Without earth current element			*			
	1 A	rated current		E1			
	5 A			E5			
Housing (12TE)	19"-rack door installation					A	
						D	
Communication protocol	RS485 Pro Open Data; Modbus RTU						-M

\* Leave box empty, if option is not desired

## Setting list for MRM3-2

Project: \_\_\_\_\_ Job.-No.: \_\_\_\_\_

Functional group: = \_\_\_\_\_ Location: + \_\_\_\_\_ Relay code: - \_\_\_\_\_

Relay functions: \_\_\_\_\_ Password: \_\_\_\_\_

Date: \_\_\_\_\_

All settings have to be checked at site and perhaps adjusted to the object to be protected.

### Date and time settings

Funktion		I	IE	Default settings	
⊕	Year settings	year	X	X	Y = 00
⊕	Month settings	month	X	X	M=01
⊕	Day settings	day	X	X	D=01
⊕	Setting of the hours	hour	X	X	h=00
⊕	Setting of the minutes	minute	X	X	m=00
⊕	Setting of the seconds	second	X	X	s=00

### System parameter

Funktion		I	IE	Default settings	Actual settings
L1; L2; L3	I <sub>primär</sub> (phase)	X	X	SEK	
E	I <sub>primär</sub> (earth)		X	SEK	
h	Operating hour meter – Years	X	X	Y=00	
h	Operating hour meter – Hours	X	X	0000	
No.	Number of motor starts	X	X	0000	
	50 / 60 Hz	X	X	50Hz	
	Actuation indication	X	X	NO_F	

## Protection parameters

		Unit	I	IE	Default setting	Actual setting	
LED	Function				Set1/Set 2	Set1	Set 2
P2	Parameter set change-over switch		X	X	SET1		
I <sub>B&gt;</sub>	Basic current of the thermal overload protection	x I <sub>N</sub>	X	X	0.20		
k	Constant		X	X	1.00		
I <sub>B&gt;</sub> + t>	Excitation delay of the I <sub>B&gt;</sub> *k - steps	s	X	X	0.04		
I <sub>B&gt;</sub> + τ <sub>W</sub>	Warning/tripping of the thermal overloadstep		X	X	trip		
τ <sub>W</sub> + Start	t2x and t6x min. tripping time at a start		X	X	EXIT		
τ <sub>W</sub>	Time constant (warming)	min	X	X	0.5m		
τ <sub>C</sub>	Time constant (cooling down)		X	X	1.0		
g>	Warning element for thermal overload	%	X	X	20		
I<	Pick-up value for phase undercurrent element	x I <sub>N</sub>	X	X	EXIT		
I< + t>	Tripping time of the undercurrent element	s	X	X	0.10		
I>	Pick-up value of the phase over current element	x I <sub>N</sub>	X	X	0.20		
I> + CHAR	Trip characteristics for the phase over current element		X	X	DEFT		
I> + t>	Tripping time (factor) for the phase over current element	(s)	X	X	0.04		
I>+CHAR + t>	Reset mode for the tripping characteristics		X	X	0s		



## Protection Parameters (Contin.)

		Unit	I	IE	Default setting	Actual setting	
LED	Function				Set1/Set2	Set1	Set2
I>> + Start	Pick-up value for the phase short-circuit element at start	x I <sub>N</sub>	X	X	0.50		
I>> + Start + t>	Tripping time of the phase short-circuit tripping at start-up	s	X	X	0.04		
I>>	Pick-up value for the phase short-circuit element in operation	x I <sub>N</sub>	X	X	0.50		
I>> + t>	Tripping time of the phase short-circuit element	s	X	X	0.04		
I2>	Pick-up value of the load unbalance element	x I <sub>N</sub>	X	X	0.020		
I2> + CHAR	Trip characteristic of the load unbalance element		X	X	DEFT		
I2> + t>	Tripping time of the unbalanced load element	s	X	X	1.0		
I2>+CHAR + t>	Reset mode for the load unbalance element		X	X	0s		
I <sub>E</sub> >	Pick-up value of the earth fault element	(s)		X	0.010		
I <sub>B</sub> >	Warning/tripping of the earth over current steps		X	X	trip		
I <sub>E</sub> > + CHAR	Trip characteristic earth fault element			X	DEFT		
I <sub>E</sub> >+ t>	Tripping time (factor) earth fault element	(s)		X	0.04		
I <sub>E</sub> >+ CHAR + t>	Reset mode earth fault element			X	0s		
CB + t>	Tripping time CB failure protection	s	X	X	EXIT		
Trip + t>	Tripping time external trip	s	X	X	0.10		
Block + Trip	Trip blocking at excessive phase current	x I <sub>N</sub>	X	X	EXIT		

**Start parameters**

Function		Unit	I	IE	Default setting	Actual setting	
LED	Function				Set1/Set2	Set1	Set2
No.+Start	Duration of a start cycle	min.	X	X	30		
No.	Number of starts per cycle		X	X	10		
Start+Bloc k+t>	Start blocking time	min	X	X	30		
Start + CHAR	Characteristic for the starting time		X	X	DEFT		
I <sub>B</sub> > + Start	Rated starting current	x I <sub>N</sub>			EXIT		
Start + t>	Starting time of engine (rated starting time with rated voltage)	(s)	X	X	EXIT		
0 + I> + t>	Time of START recognition or MOTOR RUNNING	s	X	X	0.20		
0 + I< + t>	Stopping time	s	X	X	0.50		

**Parameters for the fault recorder**

LED	Function	Unit	I	IE	Default setting	Actual setting
FR	Number of recordings				4	
FR	Storage of the recording at the event				TRIP	
FR	Time period prior to the trigger impulse	s			0.05	

**Interface parameters**

LED	Function	I	IE	Default setting	Actual setting
RS	Slave Address of the serial interface		X	1	
RS*	Baud rate of the serial interface		X	9600	
RS*	Parity check of the serial interface		X	even	

\*only with Modbus Protocol

### Assignment of the blocking functions

LED	Function	Default setting*		Actual setting	
		Set 1	Set 2	Set 1	Set 2
g>	Overload warning	NO_B	NO_B		
I <sub>B</sub> > + τ <sub>w</sub>	Overload element	NO_B	NO_B		
I<	Undercurrent element	NO_B	NO_B		
I>	Over current element	NO_B	NO_B		
I>> + Start	Short-circuit element at start	PR_B	PR_B		
I>>	Short-circuit element, in operation	PR_B	PR_B		
I <sub>2</sub> >	Load unbalance element	NO_B	NO_B		
IE>	Earth current element	NO_B	NO_B		
CB	CB failure protection	NO_B	NO_B		
Trip	External trip	NO_B	NO_B		

\*NO\_B = not blocked; BLOC = blocked; PR\_B = blocking actuation; TR\_B = blocking trip

### Assignment of the reset functions

LED	Function	Default setting		Actual setting	
		Set 1	Set 2	Set 1	Set 2
g>	Overload warning	AUTO	AUTO		
I <sub>B</sub> >	Overload alarm	AUTO	AUTO		
I <sub>B</sub> > + τ <sub>w</sub>	Overload trip	AUTO	AUTO		
I<	Undercurrent alarm	AUTO	AUTO		
I< + t>	Undercurrent trip	AUTO	AUTO		
I>	Over current alarm	AUTO	AUTO		
I> + t>	Over current trip	AUTO	AUTO		
I>> + Start +t>	Short-circuit tripping during start-up	AUTO	AUTO		
I>>	Short-circuit alarm in operation	AUTO	AUTO		
I>> + t>	Short-circuit trip	AUTO	AUTO		
I <sub>2</sub> >	Load unbalance actuation	AUTO	AUTO		
I <sub>2</sub> > + t>	Load unbalance trip	AUTO	AUTO		
IE>	Earth current alarm	AUTO	AUTO		
IE> + t>	Earth current trip	AUTO	AUTO		
CB	CB failure protection	AUTO	AUTO		
Trip	External trip	AUTO	AUTO		

\* AUTO = Automatic Reset; HAND = Manual Reset

\*\* I>>+Start Short-circuit excitation during start-up is always auto-reset

## Assignment of the Output Relays

LED	Function	Relay 1		Relay 2		Relay 3		Relay 4	
		Default setting	Actual setting	Default setting	Actual setting	Default setting	Actual setting	Default setting	Actual setting
g>	g> Actuation			X					
l <sub>B</sub> >	l <sub>B</sub> > Alarm			X					
l <sub>B</sub> >+τ <sub>w</sub>	l <sub>B</sub> > Trip	X							
l<	l< Alarm			X					
l<+t>	l< Trip	X							
l>	l> Alarm			X					
l>+t>	l> Trip	X							
l>>+Start	l>> Alarm at Start			X					
l>>+Start+t>	l>> Tripping at Start	X							
l>>	l>> Alarm			X					
l>>+t>	l>> Trip	X							
l2>	l2> Alarm			X					
l2>+t>	l2> Trip	X							
lE>	lE> Alarm			X					
lE>+t>	lE> Trip	X							
CB	CB failure protection								
Trip	Ext. trip, undelayed	X							
Trip + t>	Ext. trip, delayed	X							
Start + Block+t>	Start blocking					X			
Start	Motor is starting								
S/R	Motor is running							X	
Start+t>	Excessive start-up time	X							
P2	Parameter Set 2 is active								

### Setting of the Coding Plugs

Coding plug	J1		J2		J3	
	Default setting	Actual setting	Default setting	Actual setting	Default setting	Actual setting
Plugged-in						
Unplugged	X		No function		No function	

### Digital inputs

Coding plug	Function	Low/High range for blocking input	
		Default setting	Actual setting
Terminal	Low=plugged-in/High=unplugged		
D8 / A2	Parameter set change-over switch	Plugged-in	
D8 / A5	Ext. Trigger for the fault recorder	Plugged-in	
D8 / A6	Recognition „Motor Running“	Plugged-in	
D8 / A7	Ext. trip, undelayed	Plugged-in	
D8 / A8	Ext. trip, delayed	Plugged-in	
D8 / C8	Reset function	Plugged-in	
D8 / E8	Blocking function	Plugged-in	

This technical description applies as from the use of

Software Version	D01-2.01	MRM3-2-IE MRM3-2-I
Modbus Protocol Software Version	D51-2.01	MRM3-2-IE-M MRM3-2-I-M

# HighTECH Line

[https://docs.SEGelectronics.de/mrm3\\_2](https://docs.SEGelectronics.de/mrm3_2)  
<https://docs.SEGelectronics.de/mr>

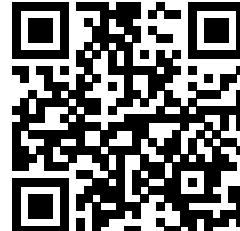
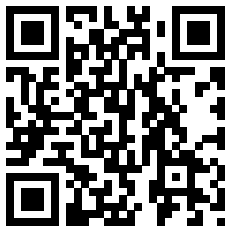

SEG Electronics GmbH reserves the right to update any portion of this publication at any time. Information provided by SEG Electronics GmbH is believed to be correct and reliable. However, SEG Electronics GmbH assumes no responsibility unless otherwise expressly undertaken.



SEG Electronics GmbH  
Krefelder Weg 47 • D-47906 Kempen (Germany)  
Postfach 10 07 55 (P.O.Box) • D-47884 Kempen (Germany)  
Telephone: +49 (0) 21 52 145 1

Internet: [www.SEGelectronics.de](http://www.SEGelectronics.de)

Sales  
Telephone: +49 (0) 21 52 145 331  
Fax: +49 (0) 21 52 145 354  
E-mail: [info@SEGelectronics.de](mailto:info@SEGelectronics.de)

Service  
Telephone: +49 (0) 21 52 145 614  
Fax: +49 (0) 21 52 145 354  
E-mail: [info@SEGelectronics.de](mailto:info@SEGelectronics.de)

SEG Electronics has company-owned plants, subsidiaries, and branches, as well as authorized distributors and other authorized service and sales facilities throughout the world.

Complete address / phone / fax / email information for all locations is available on our website.