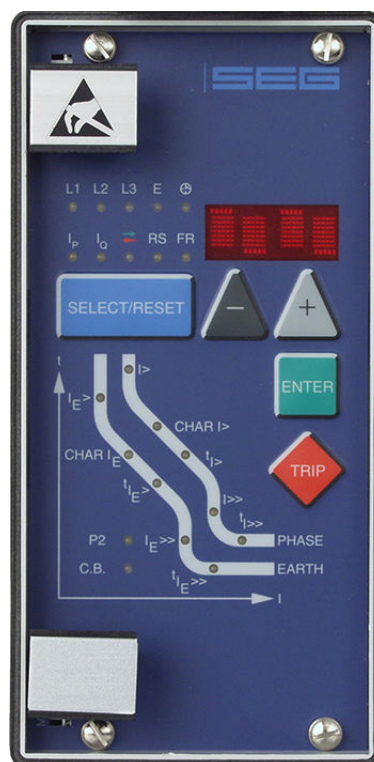


MANUAL

HighTECH Line | PROTECTION TECHNOLOGY
MADE SIMPLE

MRI1 | DIGITAL MULTIFUNCTIONAL RELAY FOR
TIME-OVERCURRENT PROTECTION



DIGITAL MULTIFUNCTIONAL RELAY FOR TIME-OVERCURRENT PROTECTION

Original document

English

Revision: A

1 Introduction and application

2 Features and characteristics

3 Design

- 3.1 Connections
 - 3.1.1 Analog input circuits
 - 3.1.2 Output relays of *MRI1*-relays
 - 3.1.3 Blocking input
 - 3.1.4 External reset input
- 3.2 Relay output contacts
 - 3.2.1 Parameter settings
- 3.3 LEDs

4 Working principle

- 4.1 Analog circuits
- 4.2 Digital circuits
- 4.3 Directional feature
- 4.4 Earth fault protection
 - 4.4.1 Generator stator earth fault protection
 - 4.4.2 System earth fault protection
- 4.5 Earth-fault directional feature (ER/XR-relay type)
- 4.6 Determining earth short-circuit fault direction
- 4.7 Demand imposed on the main current transformers

5 Operation and setting

- 5.1 Display
- 5.2 Setting procedure
 - 5.2.1 Pickup current for phase overcurrent element ($I_{>}$)
 - 5.2.2 Time current characteristics for phase overcurrent element (CHAR $I_{>}$)
 - 5.2.3 Trip delay or time multiplier for phase overcurrent element ($t_{>}$)
 - 5.2.4 Reset setting for inverse time tripping characteristics in the phase current path
 - 5.2.5 Current setting for high set element ($I_{>>}$)
 - 5.2.6 Trip delay for high set element ($t_{>>}$)
 - 5.2.7 Relay characteristic angle RCA
 - 5.2.8 Voltage transformer connection for residual voltage measuring (3pha/e-n/1:1)
 - 5.2.9 Pickup value for residual voltage U_E (ER/XR-relay type)
 - 5.2.10 Pickup current for earth fault element ($I_{E>}$)
 - 5.2.11 WARN/TRIP changeover (E/X and ER/XR-relay type)
 - 5.2.12 Time current characteristics for earth fault element (CHAR IE; (not for ER/XR-relay type)
 - 5.2.13 Trip delay or time multiplier for earth fault element ($t_{E>>}$)
 - 5.2.14 Reset mode for inverse time tripping in earth current path

- 5.2.15 Current setting for high set element of earth fault supervision ($I_{E>>}$)
- 5.2.16 Trip delay for high set element of earth fault supervision ($t_{E>>}$)
- 5.2.17 COS/SIN Measurement (ER/XR-relay type)
- 5.2.18 SOLI/RESI changeover (SR-relay type)
- 5.2.19 Circuit breaker failure protection t_{CBFP}
- 5.2.20 Nominal frequency
- 5.2.21 Display of the activation storage (FLSH/NOFL)
- 5.2.22 Adjustment of the slave address
- 5.2.23 Setting of Baud-rate (applies for Modbus Protocol only)
- 5.2.24 Setting of parity (applies for Modbus Protocol only)
- 5.2.25 Blocking the protection functions and assignment of the output relays
- 5.3 Setting value calculation
 - 5.3.1 Definite time overcurrent element
 - 5.3.2 Inverse time overcurrent element
- 5.4 Indication of measuring and fault values
 - 5.4.1 Indication of measuring values
 - 5.4.2 Indication of fault data
 - 5.4.3 Fault memory (not for ER/XR types)
- 5.5 Reset

6 Relay testing and commissioning

- 6.1 Power-On
- 6.2 Testing the output relays and LEDs
- 6.3 Checking the set values
- 6.4 Secondary injection test
 - 6.4.1 Test equipment
 - 6.4.2 Example of test circuit for *MRI1* relays without directional feature
 - 6.4.3 Checking the input circuits and measured values
 - 6.4.4 Checking the operating and resetting values of the relay
 - 6.4.5 Checking the relay operating time
 - 6.4.6 Checking the high set element of the relay
 - 6.4.7 Example of a test circuit for *MRI1* relay with directional feature
 - 6.4.8 Test circuit earth fault directional feature
 - 6.4.9 Checking the external blocking and reset functions
 - 6.4.10 Test of the CB failure protection
- 6.5 Primary injection test
- 6.6 Maintenance

7 Technical data

- 7.1 Measuring input circuits
- 7.2 Common data
- 7.3 Setting ranges and steps
 - 7.3.1 Time overcurrent protection (*I-Type*)
 - 7.3.2 Earth fault protection (*SR-Type*)
 - 7.3.3 Earth fault protection (*E/X-Type*)
 - 7.3.4 Earth fault protection (*ER/XR-Type*)
 - 7.3.5 Switch failure protection
 - 7.3.6 Interface parameter
 - 7.3.7 Inverse time overcurrent protection relay
 - 7.3.8 Direction unit for phase overcurrent relay
 - 7.3.9 Determination of earth fault direction
(*MR11-ER/XR*)
 - 7.3.10 Determination of earth fault direction
(*MR11-SR*)
- 7.4 Inverse time characteristics
- 7.5 Output contacts

8 Order form

1 Introduction and application

The *MR11* digital multifunctional relay is a universal time overcurrent and earth fault protection device intended for use in medium-voltage systems, either with an isolated/compensated neutral point or for networks with a solidly earthed/resistance-earthed neutral point.

- The protective functions of *MR11* which are implemented in only one device are summarized as follows:
- Independent (Definite) time overcurrent relay.
- Inverse time overcurrent relay with selectable characteristics.
- Integrated determination of fault direction for application to doubly infeeded lines or meshed systems.
- Two-element (low and high set) earth fault protection with definite or inverse time characteristics.
- Integrated determination of earth fault direction for application to power system networks with isolated or arc suppressing coil (Peterson coil) neutral earthing. (ER/XR-relay type).
- Integrated determination of earth short-circuit fault direction in systems with solidly-earthed neutral point or in resistance-earthed systems (SR-relay type).

Furthermore, the relay *MR11* can be employed as a back-up protection for distance and differential protective relays.

A similar, but simplified version of overcurrent relay *IR11* with limited functions without display and serial interface is also available.

Important:

For additional common data of all *MR*-relays please refer to manual "*MR* - Digital Multifunctional relays". On page 41 of this manual you can find the valid software versions.

2 Features and characteristics

- Digital filtering of the measured values by using discrete Fourier analysis to suppress the high frequency harmonics and DC components induced by faults or system operations
- Selectable protective functions between:
 - definite time overcurrent relay and
 - inverse time overcurrent relay
- Selectable inverse time characteristics according to BS 142 and IEC 255-4:
 - Normal Inverse
 - Very Inverse
 - Extremely Inverse
- Reset setting for inverse time characteristics selectable
- High set overcurrent unit with instantaneous or definite time function.
- Two-element (low and high set) overcurrent relay both for phase and earth faults.
- Directional feature for application to the doubly infeeded lines or meshed systems.
- Earth fault directional feature selectable for either isolated or compensated networks.
- sensitive earth fault current measuring with or without directional feature (X and XR-relay type)
- Determination of earth short-circuit fault direction for systems with solidly-earthed or resistance-earthed neutral point.
- Numerical display of setting values, actual measured values and their active, reactive components, memorized fault data, etc.
- Withdrawable modules with automatic short circuit of C.T. inputs when modules are withdrawn.
- Blocking e.g. of high set element (e.g. for selective fault detection through minor overcurrent protection units after unsuccessful AR).
- Relay characteristic angle for phase current directional feature selectable
- Dwell time selectable
- Switch failure protection
- Storage of tripping values and shut-down times (not ER/XR versions) (t_{CBFP}) of eight failure events
- Free assignment of output relays
- Serial data exchange via RS485 interface possible; alternatively with SEG RS485 Pro-Open Data Protocol or Modbus Protocol
- Suppression of indication after an activation (LED flash)

3 Design

3.1 Connections

Phase and earth current measuring:

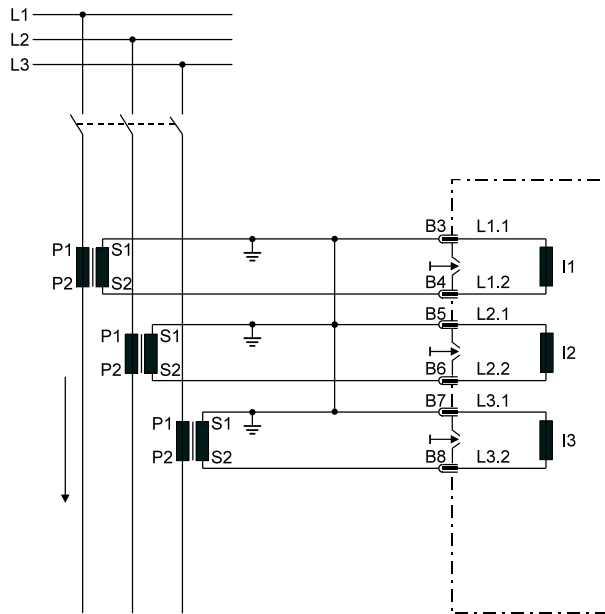


Figure 3.1: Measuring of the phase currents for over-current- and short-circuit protection ($I_{>}$, $I_{>>}$)

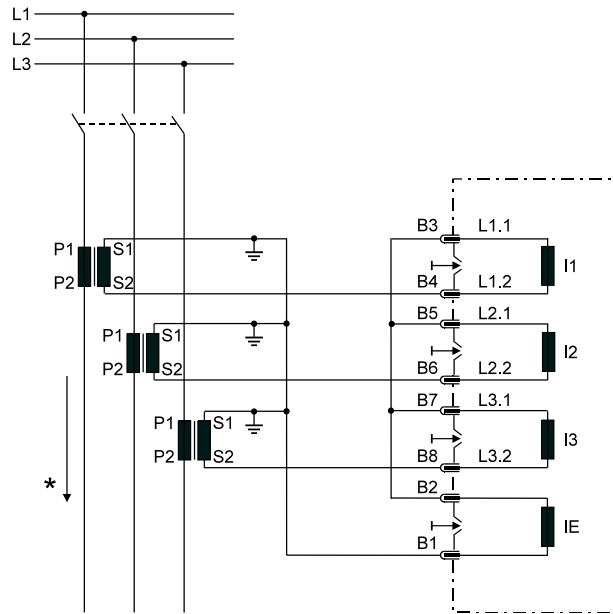


Figure 3.3: Phase current measuring and earth-current detection by means of Holmgreen-circuit.

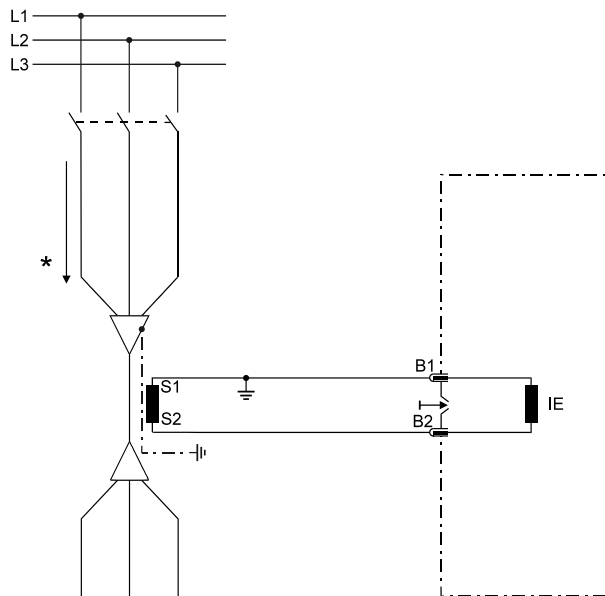


Figure 3.2: Earth-fault measuring by means of ring-core C.T. (I_e)

When phase- and earth-fault current measuring are combined, the connection has to be realized as per Figure 3.1 and Figure 3.2.

* This arrow shows the current flow in forward direction, for this LED $\rightarrow\leftarrow$ lights up green

This connection can be used with three existing phase current transformers when combined phase and earth-current measuring is required.

Disadvantage of holmgreen-circuit:
At saturation of one or more C.Ts the relay detects seeming an earth current.

Voltage measuring for the directional detection:

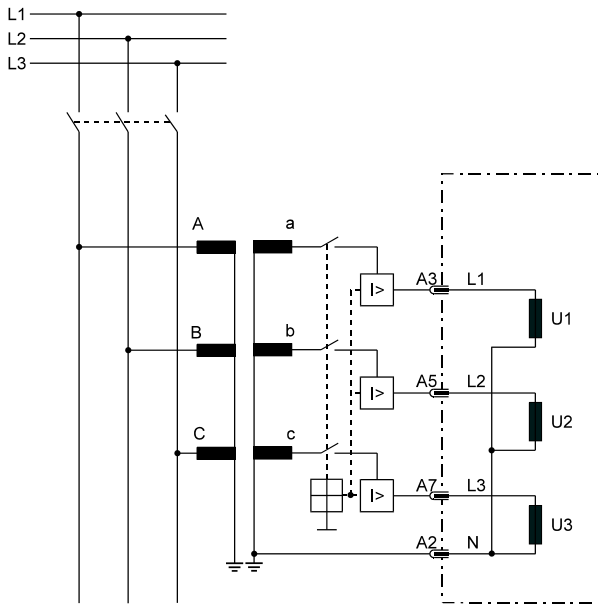


Figure 3.4: Measuring of the phase voltages for the directional detection at overcurrent, short-circuit or earth-fault protection ($I>$, $I>>$, $I_{E>}$ and $I_{E>>}$).

For details on the connection of ER/XR-unit type c.t.s, see para 4.5.

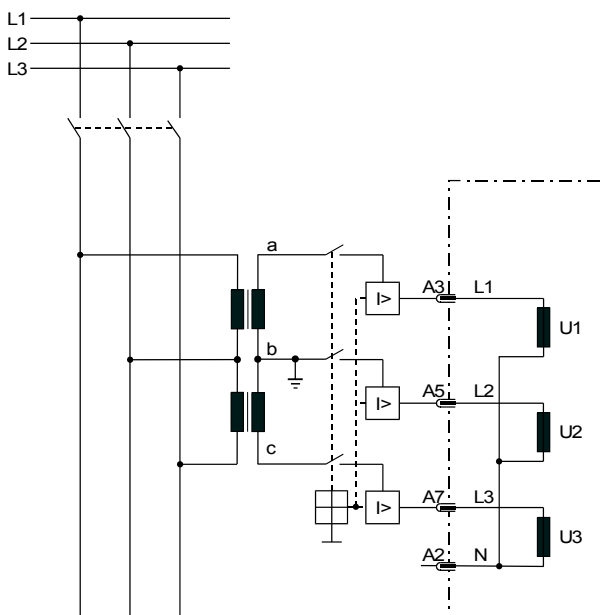


Figure 3.5: Voltage transformer in V-connection for the directional detection at overcurrent and short-circuit protection.

The V-connection can not be applied at earth fault directional feature.

3.1.1 Analog input circuits

The protection unit receives the analog input signals of the phase currents I_{L1} (B3-B4), I_{L2} (B5-B6), I_{L3} (B7-B8) and the current I_E (B1-B2), phase voltages U_1 (A3), U_2 (A5), U_3 (A7) with A2 as star point, each via separate input transformers.

The constantly detected current measuring values are galvanically decoupled, filtered and finally fed to the analog/digital converter.

For the unit type with earth fault directional features (ER/XR-relay type) the residual voltage U_E in the secondary circuit of the voltage transformers is internally formed.

In case no directional feature for the phase current path is necessary the residual voltage from the open delta winding can directly be connected to A3 and A2.

See Chapter 4.4 for voltage transformer connections on isolated/compensated systems.

3.1.2 Output relays of MR11-relays

The MR11 is equipped with 5 output relays. Apart from the relay for self-supervision, all protective functions can be optionally assigned:

- Relay 1: C1, D1, E1 and C2, D2, E2
- Relay 2: C3, D3, E3 and C4, D4, E4
- Relay 3: C5, D5, E5
- Relay 4: C6, D6, E6
- Self-supervision C7, D7, E7

All trip and alarm relays are working current relays, the relay for self supervision is an idle current relay.

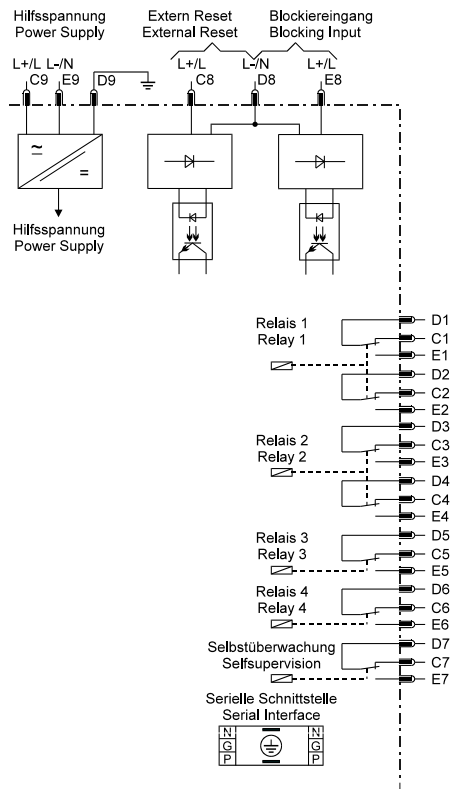
3.1.3 Blocking input

The blocking functions adjusted before will be blocked if an auxiliary voltage is connected to (terminals) D8/E8. (See chapter 5.2.25)

3.1.4 External reset input

Please refer to chapter 5.5.

3.2 Relay output contacts



Contacts at **MR11**:

To prevent that the C.B. trip coil circuit is interrupted by the **MR11** first, i.e. before interruption by the C.B. auxiliary contact, a dwell time is fixed. This setting ensures that the **MR11** remains in self holding for 200ms after the fault current is interrupted.

Figure 3.6

3.2.1 Parameter settings (see chapter 5)

Relay-type MRI1-	I	IE IX	IRE IRX	IR	IER IXR	IRER IRXR	ER XR	E X	ISR	IRSR	SR
I>	X	X	X	X	X	X			X	X	
CHAR I>	X	X	X	X	X	X			X	X	
t _{I>}	X	X	X	X	X	X			X	X	
0s / 60s ³⁾	X	X	X	X	X	X			X	X	
I>>	X	X	X	X	X	X			X	X	
t _{I>>}	X	X	X	X	X	X			X	X	
RCA			X	X		X				X	
1:1 / 3 pha / e-n					X	X	X				
U _E					X	X	X				
I _{E>}		X	X		X	X	X	X	X	X	X
warn/trip		X	X		X	X	X	X			
CHAR I _E		X	X					X	X	X	X
t _{I_E}		X	X		X	X	X	X	X	X	X
0s/60 s ⁴⁾		X	X					X	X	X	X
I _{E>>}		X	X		X	X	X	X	X	X	X
t _{I_{E>>}}		X	X		X	X	X	X	X	X	X
sin/cos					X	X	X				
solli/resi									X	X	X
tCBFP	X	X	X	X	X	X	X	X	X	X	X
50/60 Hz	X	X	X	X	X	X	X	X	X	X	X
LED-Flash	X	X	X	X	X	X	X	X	X	X	X
RS485/Slaveaddress	X	X	X	X	X	X	X	X	X	X	X
Baud-Rate ³⁾	X	X	X	X	X	X	X	X	X	X	X
Parity-Check ³⁾	X	X	X	X	X	X	X	X	X	X	X

Table 3.1: Parameters of the different relay types.

¹⁾ Reset setting for inverse time characteristics in phase current path

²⁾ Reset setting for inverse time characteristics in earth current path

³⁾ Only devices with Modbus-Protocol

Additional parameters:

Relay-type MRI1-	I	IE IX	IRE IRX	IR	IER IXR	IRER IRXR	ER XR	E X	ISR	IRSR	SR
Blocking mode	X	X	X	X	X	X	X	X	X	X	X
Relay parameterising	X	X	X	X	X	X	X	X	X	X	X
Fault recorder	X	X	X	X				X	X	X	X

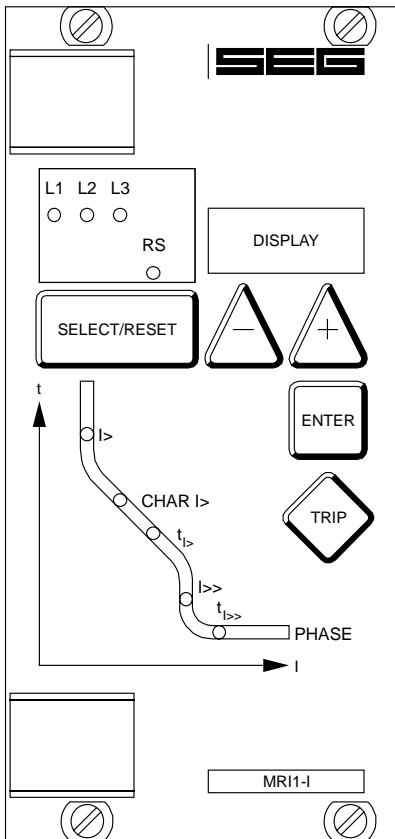


Figure 3.7: Front panel MRI1-I

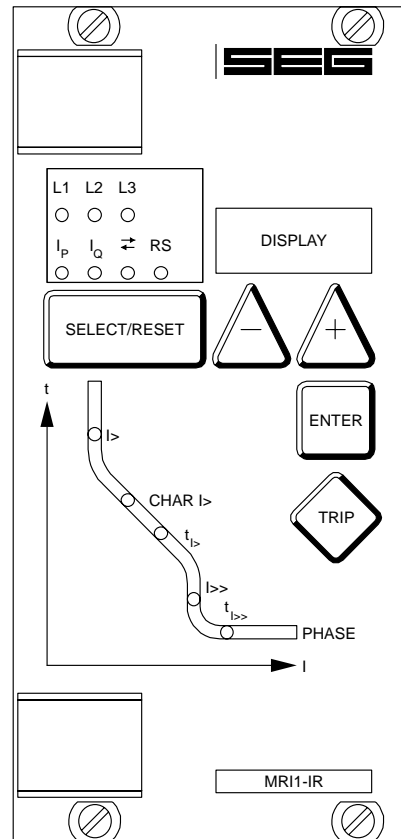


Figure 3.9: Front panel MRI1-IR

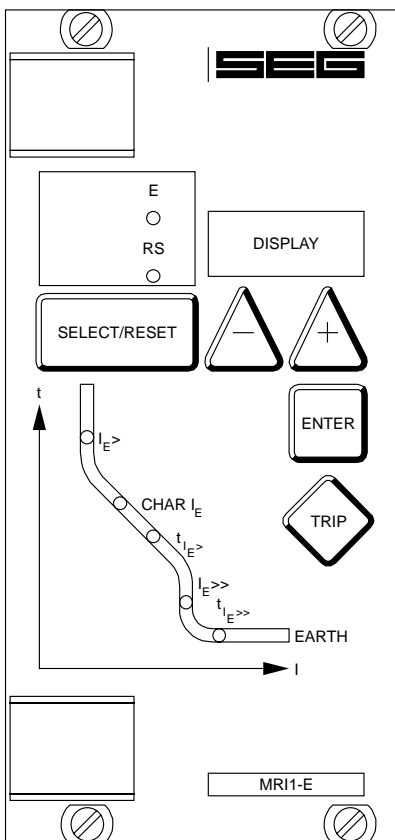


Figure 3.8: Front panel MRI1-E/X

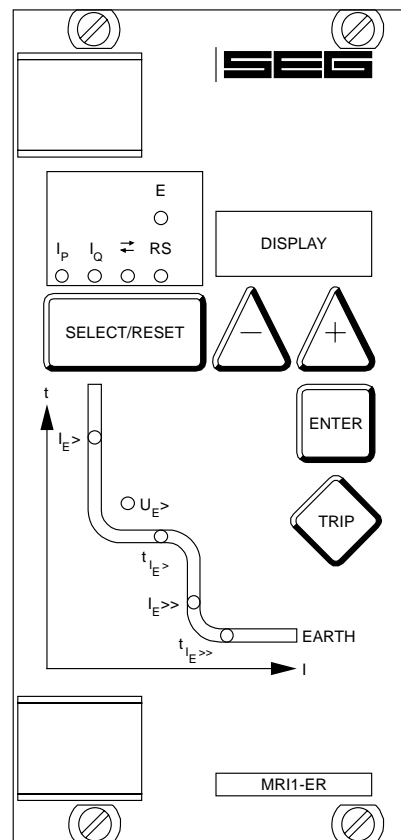


Figure 3.10: Front panel MRI1-ER/XR

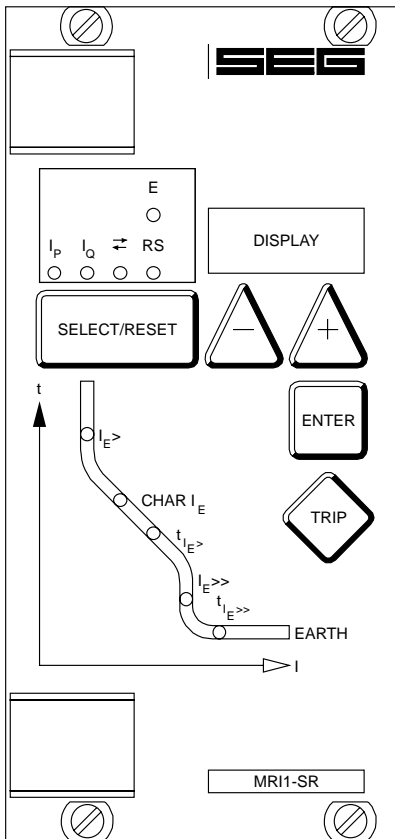


Figure 3.11: Front panel MRI1-SR

3.3 LEDs

The LEDs left from the display are partially bi-colored, the green indicating measuring, and the red fault indication.

MRI1 with directional addition have a LED (green- and red arrow) for the directional display. At pickup/trip and parameter setting the green LED lights up to indicate the forward direction, the red LED indicates the reverse direction.

The LED marked with letters RS lights up during setting of the slave address of the device for serial data communication.

The LEDs arranged at the characteristic points on the setting curves support the comfortable setting menu selection. In accordance with the display 5 LEDs for phase fault overcurrent relay and 5 LEDs for earth-fault relay indicate the corresponding menu point selected.

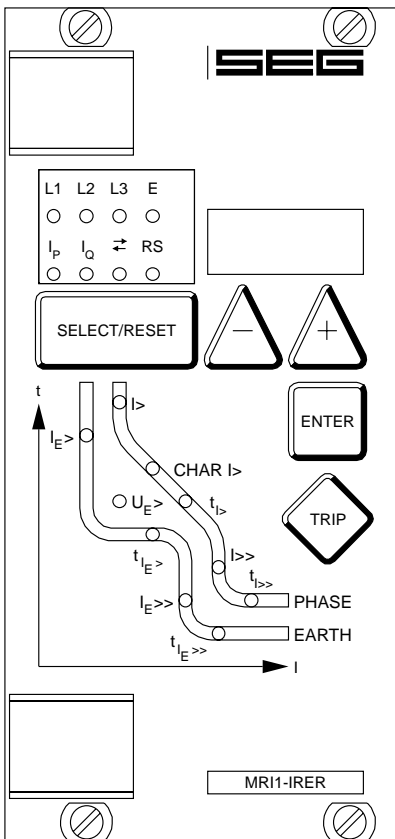


Figure 3.12: Front panel MRI1-IRER/IRXR and MRI1-IER/IXR

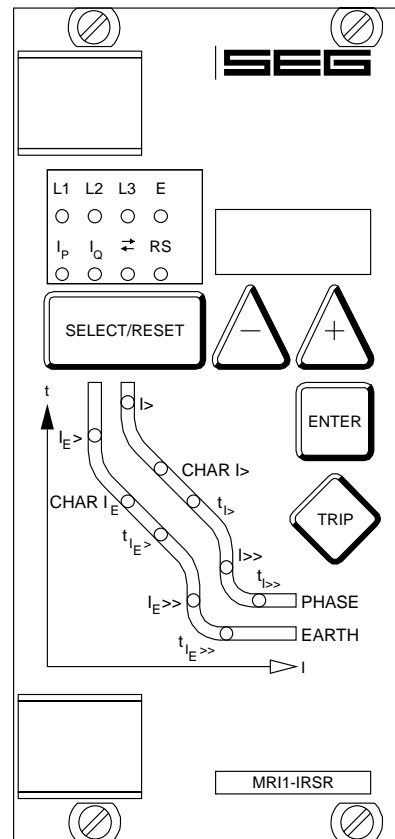


Figure 3.13: Front panel MRI1-IRSR; MRI1-IRE/IRX and MRI1-ISR

4 Working principle

4.1 Analog circuits

The incoming currents from the main current transformers on the protected object are converted to voltage signals in proportion to the currents via the input transformers and burden. The noise signals caused by inductive and capacitive coupling are suppressed by an analog R-C filter circuit.

The analog voltage signals are fed to the A/D-converter of the microprocessor and transformed to digital signals through Sample- and Hold-circuits. The analog signals are sampled at 50 Hz (60 Hz) with a sampling frequency of 800 Hz (960 Hz), namely, a sampling rate of 1.25 ms (1.04 ms) for every measuring quantity. (16 scans per period).

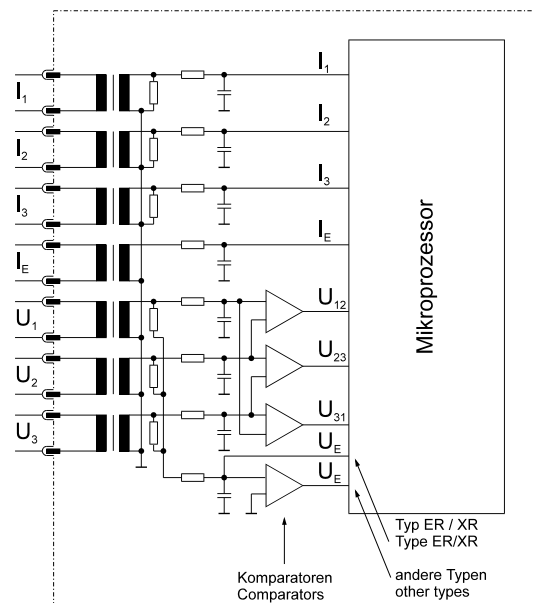


Figure 4.1: Block diagram

4.2 Digital circuits

The essential part of the *MR11* relay is a powerful microcontroller. All of the operations, from the analog digital conversion to the relay trip decision, are carried out by the microcontroller digitally. The relay program is located in an EPROM (Electrically-Programmable-Read-Only-Memory). With this program the CPU of the microcontroller calculates the three phase currents and ground current in order to detect a possible fault situation in the protected object.

For the calculation of the current value an efficient digital filter based on the Fourier Transformation (DFFT - Discrete Fast Fourier Transformation) is applied to suppress high frequency harmonics and DC components caused by fault-induced transients or other system disturbances.

The calculated actual current values are compared with the relay settings. If a phase current exceeds the pickup value, an alarm is given and after the set trip delay has elapsed, the corresponding trip relay is activated.

The relay setting values for all parameters are stored in a parameter memory (EEPROM - Electrically Erasable Programmable Read-only Memory), so that the actual relay settings cannot be lost, even if the power supply is interrupted.

The microprocessor is supervised by a built-in "watchdog" timer. In case of a failure the watchdog timer resets the microprocessor and gives an alarm signal, via the output relay "self supervision".

4.3 Directional feature

A built-in directional element in *MR11* is available for application to doubly infeeded lines or to ring networks.

The measuring principle for determining the direction is based on phase angle measurement and therefore also on coincidence time measurement between current and voltage. Since the necessary phase voltage for determining the direction is frequently not available in the event of a fault, whichever line-to-line voltage follows the faulty phase by 90° is used as the reference voltage for the phase current. The characteristic angle at which the greatest measuring sensitivity is achieved can be set to precede the reference voltage in the range from 15° to 83° .

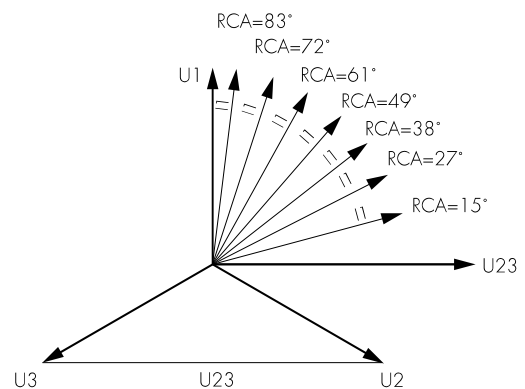


Figure 4.2: Relay characteristic angle

The TRIP region of the directional element is determined by rotating the phasor on the maximum sensitivity angle for $\pm 90^\circ$, so that a reliable direction decision can be achieved in all faulty cases.

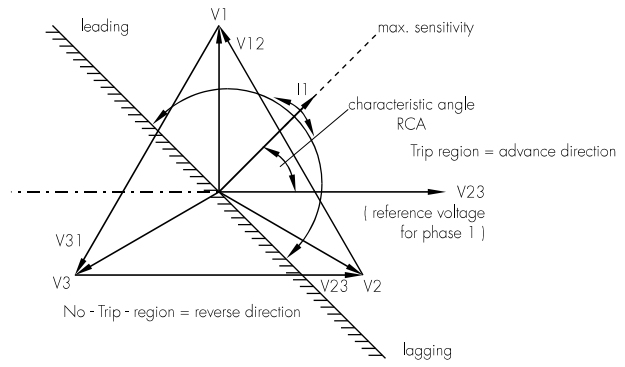
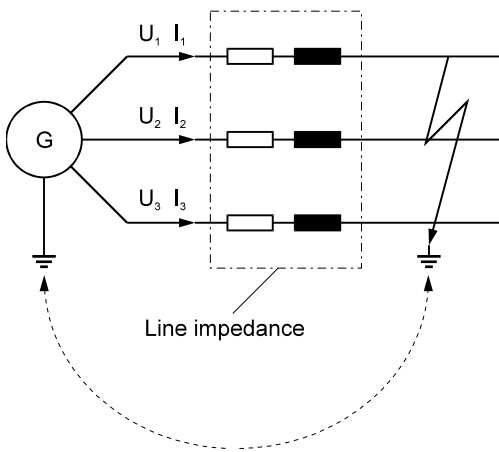
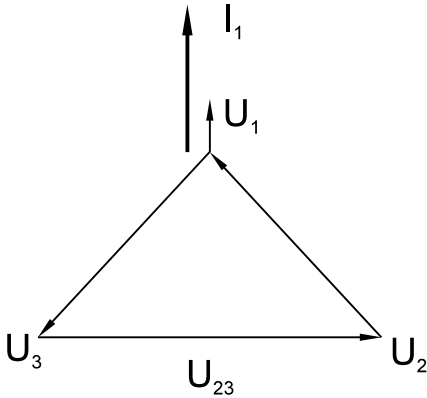
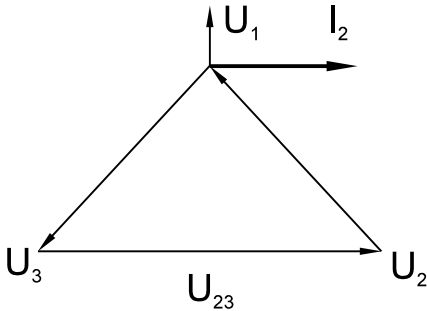


Figure 4.3: *TRIP/NO-TRIP region for directional element in MRIT. In this case the advance direction is defined as TRIP region and the reverse direction as NO-TRIP region.*

If line impedance and internal resistance of the generator is only ohmic:



If line impedance and internal resistance of the generator is only inductive:



The maximum sensitivity angle corresponds to the R/L component.

By means of accurate hardware design and by using an efficient directional algorithm a high sensitivity for the voltage sensing circuit and a high accuracy for phase angle measurement are achieved so that a correct directional decision can be made even by close three-phase faults.

As an addition, to avoid maloperations due to disturbances, at least 2 periods (40 ms at 50 Hz) are evaluated.

For the **MRIT**-overcurrent relays with directional feature different time delays or time multipliers can be set for forward and backward faults (ref. to chapter 5.2.3 and 5.2.6).

If the trip delay for backward faults is set longer than the one for forward faults, the protective relay works as a "backup"-relay for the other lines on the same busbar. This means that the relay can clear a fault in the backward direction with a longer time delay in case of refusal of the relay or the circuit breaker on the faulted line.

If the trip delay for backward faults is set out of range (on the display "EXIT"), the relay will not trip in case of backward faults.

The assignment of the output relays can be used to select in which direction the failure is to be indicated (refer also to Chapter 5.2.15). It is possible to indicate the activation and/or the tripping for each tripping direction via the output relays.

4.4 Earth fault protection

4.4.1 Generator stator earth fault protection

With the generator neutral point earthed as shown in figure 4.4 the *MR11* picks up only to phase earth faults between the generator and the location of the current transformers supplying the relay.

Earth faults beyond the current transformers, i.e. on the consumer or line side, will not be detected.

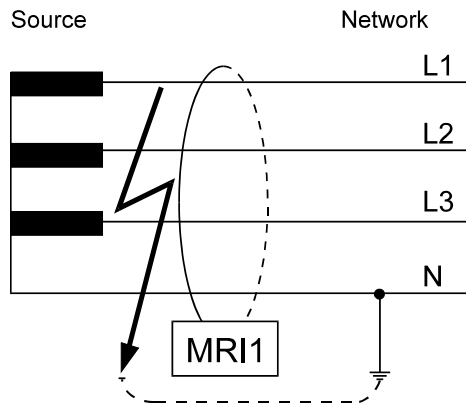


Figure 4.4: Generator stator earth fault protection

4.4.2 System earth fault protection

With the generator neutral point earthed as shown in figure 4.5, the *MR11* picks up only to earth faults in the power system connected to the generator. It does not pick up to earth faults on the generator terminals or in generator stator.

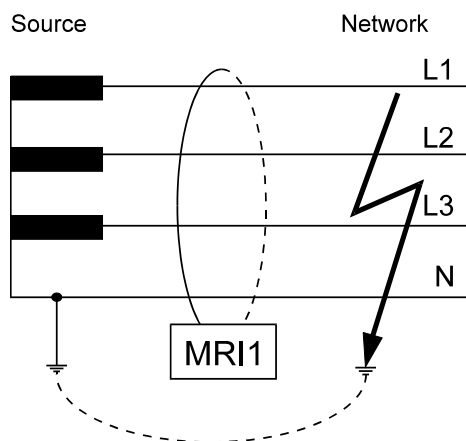


Figure 4.5: System earth fault protection

4.5 Earth-fault directional feature (ER/XR-relay type)

A built-in earth-fault directional element is available for applications to power networks with isolated or with arc suppressing coil compensated neutral point. For earth-fault direction detection it is mainly the question to evaluate the power flow direction in zero sequence system. Both the residual voltage and neutral (residual) current on the protected line are evaluated to ensure a correct direction decision. In isolated or compensated systems, measurement of reactive or active power is decisive for earth-fault detection. It is therefore necessary to set the ER/XR-relay type to measure according to $\sin \varphi$ or $\cos \varphi$ methods, depending on the neutral-point connection method.

The residual voltage U_E required for determining earth fault direction can be measured in three different ways, depending on the voltage transformer connections.

(refer to Table 4.1:) Total current can be measured by connecting the unit either to a ring core C.T. or to current transformers in a Holmgreen circuit. However, maximum sensitivity is achieved if the MRI1 protective device is connected to a ring core C. T. (see Figure 3.2).

The pick-up values $I_{E>}$ and $I_{E>>}$ (active or reactive current component for $\cos \varphi$ or $\sin \varphi$ method) for ER-relay types can be adjusted from 0.01 to $0.45 \times I_N$. For relay type **MRI1-XR** these pick-up values can be adjusted from 0.1 to $4.5 \% I_N$.

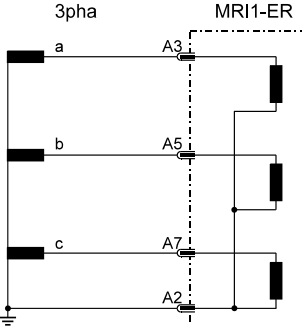
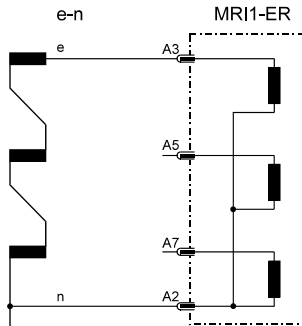
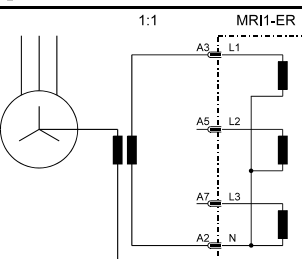
Adjustment possibility	Application	Voltage transformer connections	Measured voltage at earth fault	Correction factor for residual voltage
"3pha"	3-phase voltage transformer connected to terminals A3, A5, A7, A2 (MRI1-IRER; MRI1-IER; MRI1-ER/XR)		$\sqrt{3} \times U_N = 3 \times U_{IN}$	$K = 1 / 3$
"e-n"	e-n winding connected to terminals A3, A2 (MRI1-IRER; MRI1-ER/XR)		$U_N = \sqrt{3} \times U_{IN}$	$K = 1 / \sqrt{3}$
"1:1"	Neutral-point voltage (= residual voltage) terminals A3, A2 (MRI1-IRER; MRI1-ER/XR)		$U_{IN} = U_{NE}$	$K = 1$

Table 4.1:

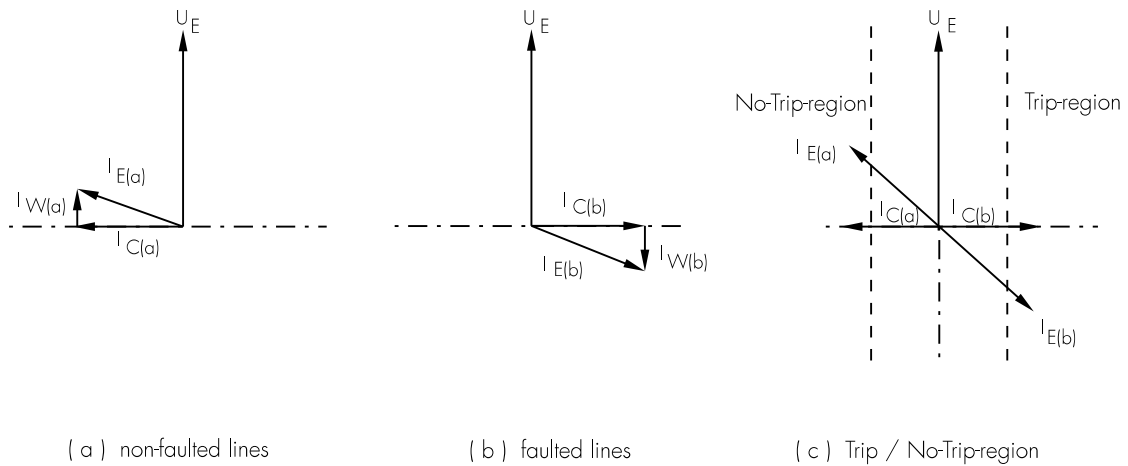


Figure 4.6: Phase position between the residual voltage and zero sequence current for faulted and non-faulted lines in case of isolated systems ($\sin \varphi$)

- U_E - residual voltage
- I_E - zero sequence current
- I_C - capacitive component of zero sequence current
- I_W - resistive component of zero sequence current

By calculating the reactive current component ($\sin \varphi$ adjustment) and then comparing the phase angle in relation to the residual voltage U_E , the ER/XR-relay type determines whether the line to be protected is earth-faulted.

On non-earth-faulted lines, the capacitive component $I_C(a)$ of the total current precedes the residual voltage by an angle of 90° . In case of a faulty line the capacity current $I_C(b)$ lags behind the residual voltage at 90° .

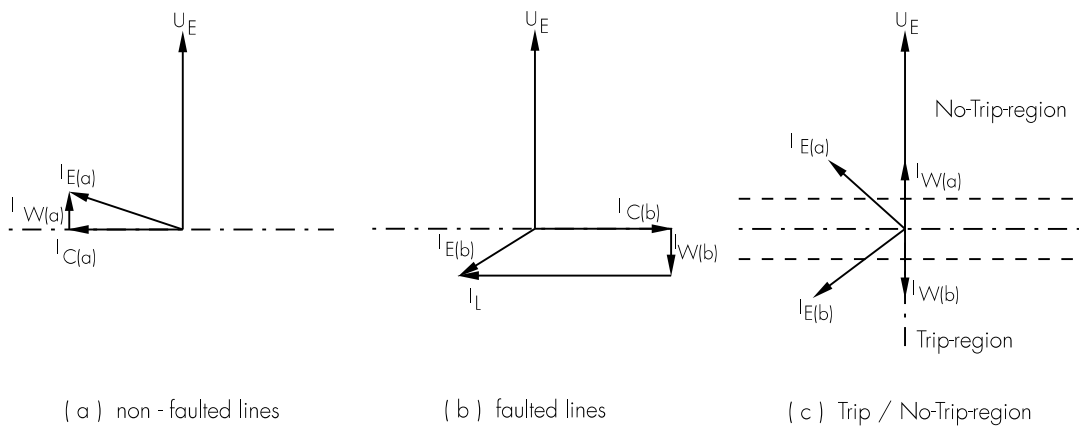


Figure 4.7: Phase position between the residual voltage and zero sequence current for faulted and non-faulted lines in case of compensated systems ($\cos \varphi$)

- U_E - residual voltage
- I_E - zero sequence current
- I_L - inductive component of zero sequence current (caused by Petersen coil)
- I_C - capacitive component of zero sequence current
- I_W - resistive component of zero sequence current

The resistive component in the non-faulted line is in phase with the residual voltage, while the resistive component in the faulted line is opposite in phase with the residual voltage.

By means of an efficient digital filter harmonics and fault transients in the fault current are suppressed. Thus, the uneven harmonics which, for instance, are caused an electric arc fault, do not impair the protective function.

In compensated mains the earth fault direction cannot be determined from the reactive current components because the reactive part of the earth current depends upon the compensation level of the mains. The ohmic component of the total current (calculated by $\cos \varphi$ adjustment) is used in order to determine the direction.

4.6 Determining earth short-circuit fault direction

The SR-relay type is used in solidly-earthed or resistance-earthed systems for determining earth short-circuit fault direction. The measuring principle for determining the direction is based on phase angle measurement and therefore also on the coincidence-time measurement between earth current and zero sequence voltage.

The zero sequence voltage U_0 required for determining the earth short-circuit fault direction is generated internally in the secondary circuit of the voltage transformers.

With SR/ISR-relay types the zero sequence voltage U_0 can be measured directly at the open delta winding (e-n). Connection A3/A2.

Most faults in a characteristic angle are predominantly inductive in character. The characteristic angle between current and voltage at which the greatest measuring sensitivity is achieved has therefore been selected to precede zero sequence voltage U_0 by 110° .

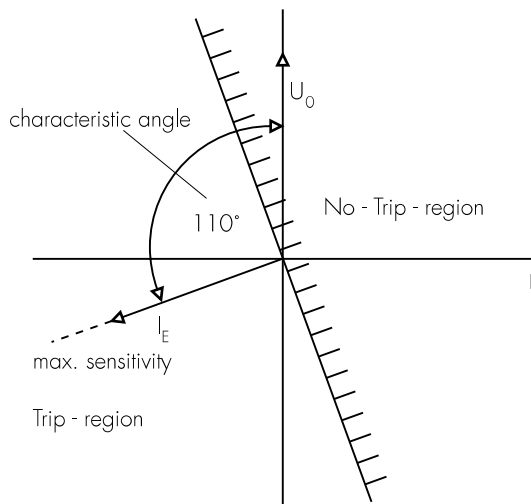


Figure 4.8: Characteristic angle in solidly earthed-systems (SOLI)

Most faults in a resistance-earthed system are predominantly ohmic in character, with a small inductive part. The characteristic angle for these types of system has therefore been set at $+170^\circ$ in relation to the zero sequence voltage U_0 (see Figure 4.9).

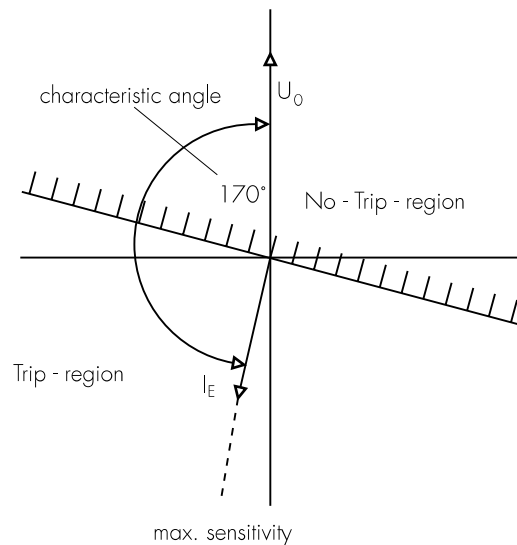


Figure 4.9: Characteristic angle in resistance-earthed systems (RESI)

The pickup range of the directional element is set by turning the current indicator at the characteristic angle through $+90^\circ$, to ensure reliable determination of the direction.

4.7 Demand imposed on the main current transformers

The current transformers have to be rated in such a way, that a saturation should not occur within the following operating current ranges:

Independent time overcurrent function: $K1 = 2$

Inverse time overcurrent function: $K1 = 20$

High-set function: $K1 = 1.2 - 1.5$

$K1 =$ Current factor related to set value

Moreover, the current transformers have to be rated according to the maximum expected short circuit current in the network or in the protected objects.

The low power consumption in the current circuit of **MRI1**, namely $<0,2$ VA, has a positive effect on the selection of current transformers. It implies that, if an electromechanical relay is replaced by **MRI1**, a high accuracy limit factor is automatically obtained by using the same current transformer.

5 Operation and setting

5.1 Display

Function	Display shows	Pressed push button	Corresponding LED
Normal operation	SEG		
Measured operating values	Actual measured values, (related to I_N ; U_E ¹⁾) (XR-type related to % I_N)	<SELECT/RESET> one time for each	L1, L2, L3, E, $U_{E\alpha}$, $I_{E\alpha}$
Measuring range overflow	max.	<SELECT/RESET>	L1, L2, L3, E
Setting values: phase ($I>$; CHAR $I>$; $t_{>}$; $I>>$; $t_{>>}$) earth ($I_{E\alpha}$; CHAR $I_{E\alpha}$; $t_{E\alpha}$; $I_{E\alpha}>$; $t_{E\alpha}>$; $U_{E\alpha}$)	Current settings Trip delay Characteristics	<SELECT/RESET> one time for each parameter	$I>$; CHAR $I>$; $t_{>}$; $I>>$; $t_{>>}$; LED $\rightarrow\leftarrow$ $I_{E\alpha}$; CHAR $I_{E\alpha}$; $t_{E\alpha}$; $I_{E\alpha}>$; $t_{E\alpha}>$; $U_{E\alpha}$
Reset setting (only available at inverse time characteristics)	0s / 60s	<SELECT/RESET> <+><->	$I>$; CHAR $I>$; $t_{>}$ $I_{E\alpha}$; CHAR $I_{E\alpha}$; $t_{E\alpha}$
Relay characteristic angle for phase cur- rent directional feature	RCA in degree (°)	<SELECT/RESET> <+><->	LED $\rightarrow\leftarrow$ (green)
Warning reverse direction ¹⁾ no warning warning	NOWA WBAK	<SELECT/RESET>	LED $\rightarrow\leftarrow$ (red) + $I>$ LED $\rightarrow\leftarrow$ (red) + $I_{E\alpha}$
Warning or Trip at earth fault measuring (E- and ER/XR-types)	TRIP WARN	<SELECT/RESET> <+><->	$I_{E\alpha}$
Measured method of the residual voltage U_E ¹⁾	3 PHA ; E-N ; 1:1	<SELECT/RESET> <+><->	$U_{E\alpha}$
residual voltage setting	voltage in volts	<SELECT/RESET><+><->	$U_{E\alpha}$
changeover of isolated (sin φ) or compensated (cos φ) networks (for ER/XR-type)	SIN COS	<SELECT/RESET> <+><->	
Change over of solidly/resistance earthed networks (SR-type)	SOLI RESI	<SELECT/RESET> <+><->	
Switch failure protection	iCBFP	<SELECT/RESET> <+><->	
Tripping protection switch failure protection	CBFP	After fault tripping	
Nominal frequency	f=50 / f=60	<SELECT/RESET><+><->	
Switch-over LED flash No LED flash	FLSH NOFL	<SELECT/RESET> <+><->	
Blocking of function	EXIT	<+> until max. setting value	LED of blocked parameter
Slave address of serial interface	1 - 32	<SELECT/RESET> <+><->	RS
Baud-Rate ²⁾	1200-9600	<SELECT/RESET> <+><->	RS
Parity-Check	even odd no	<SELECT/RESET> <+><->	RS
Recorded fault data	Tripping currents and other fault data	<SELECT/RESET> one time for each phase	L1, L2, L3, E $I>$, $I>>$, $I_{E\alpha}$, $I_{E\alpha}>$, $U_{E\alpha}$
Save parameter?	SAV?	<ENTER>	
Delete failure memory	wait	<-> <SELECT/RESET>	
Enquiry failure memory	FLT1; FLT2.....	<-><+>	L1, L2, L3, E $I>$, $I>>$, $I_{E\alpha}$, $I_{E\alpha}>$
Save parameter!	SAV!	<ENTER> for about 3 s	
Software version	First part (e.g. D01-) Sec. part (e.g. 8.00)	<TRIP> one time for each part	
Manual trip	TRI?	<TRIP> three times	
Inquire password	PSW?	<TRIP><ENTER>	
Relay tripped	TRIP	<TRIP> or after fault tripping	
Secret password input	XXXX	<SELECT/RESET> <+><-><ENTER>	
System reset	SEG	<SELECT/RESET> for about 3 s	

Table 5.1: possible indication messages on the display

¹⁾ refer to 4.4

²⁾ only Modbus

5.2 Setting procedure

After push button <SELECT/RESET> has been pressed, always the next measuring value is indicated. Firstly the operating measuring values are indicated and then the setting parameters. By pressing the <ENTER> push button the setting values can directly be called up and changed.

5.2.1 Pickup current for phase ' overcurrent element (I_s)

The setting value for this parameter that appears on the display is related to the nominal current (I_N) of the relay. This means: pickup current (I_s) = displayed value x nominal current (I_N) e.g. displayed value = 1.25 then, I_s = 1.25 x I_N.

5.2.2 Time current characteristics for phase overcurrent element (CHAR I>)

By setting this parameter, one of the following 4 messages appears on the display:

DEFT	-	Definite Time
NINV	-	Normal Inverse
VINV	-	Very Inverse
EINV	-	Extremely Inverse

Anyone of these four characteristics can be chosen by using <+> <->-push buttons, and can be stored by using <ENTER>-push button.

5.2.3 Trip delay or time multiplier for phase overcurrent element (t_r)

Usually, after the characteristic is changed, the time delay or the time multiplier should be changed accordingly. In order to avoid an unsuitable arrangement of relay modes due to carelessness of the operator, the following precautions are taken:

After the characteristic setting, the setting process turns to the time delay setting automatically. The LED t_r is going to flash yellow to remind the operator to change the time delay setting accordingly. After pressing the <SELECT>-push button, the present time delay setting value is shown on the display. The new setting value can then be changed by using <+> <->-push buttons.

If, through a new setting, another relay characteristic other than the old one has been chosen (e.g. from DEFT to NINV), but the time delay setting has not been changed despite the warning from the flashing LED, the relay will be set to the most sensitive time setting value of the selected characteristics after five minutes warning of flashing LED t_r. The most sensitive time setting value means the fastest tripping for the selected relay characteristic. When the time delay or the time multiplier is set out of range (Text "EXIT" appears on the display), the low set element of the overcurrent relay is blocked. The "WARN"-relay will not be blocked.

For the *MRI1*-version with directional feature, the different trip time delays or the time multipliers can be chosen for forward and backward faults.

By setting the trip delay, the actual set value for forward faults appears on the display first and the LED under the arrows is alight green. It can be changed with push button <+> <-> and then stored with push button <ENTER>. After that, the actual trip delay (or time multiplier) for backward faults appears on the display by pressing push button <SELECT> and the LED under the arrows is alight red.

Usually this set value should be set longer than the one for forward faults, so that the relay obtains its selectivity during forward faults. If the time delays are set equally for both forward and backward faults, the relay trips in both cases with the same time delay, namely without directional feature.

Note:

When selecting dependent tripping characteristics at relays with directional phase current detection, attention must be paid that a clear directional detection will be assured only after expiry of 40 ms.

5.2.4 Reset setting for inverse time tripping characteristics in the phase current path

To ensure tripping, even with recurring fault pulses shorter than the set trip delay, the reset mode for inverse time tripping characteristics can be switched over. If the adjustment t_{RST} is set at 60s, the tripping time is only reset after 60s faultless condition. This function is not available if t_{RST} is set to 0. With fault current cease the trip delay is reset immediately and started again at recurring fault current.

5.2.5 Current setting for high set element ($I_{>>}$)

The current setting value of this parameter appearing on the display is related to the nominal current of the relay

This means: $I_{>>} = \text{displayed value} \times I_N$.

When the current setting for high set element is set out of range (on display appears "EXIT"), the high set element of the overcurrent relay is blocked.

The high set element can be blocked via terminals E8/D8 if the corresponding blocking parameter is set to bloc (refer to chapter 5.2.25).

5.2.6 Trip delay for high set element ($t_{I_{>>}}$)

Independent from the chosen tripping characteristic for $I_{>}$, the high set element $I_{>>}$ has always a definite-time tripping characteristic. An indication value in seconds appears on the display.

The setting procedure for forward- or backward faults, described in chapter 5.2.3, is also valid for the tripping time of the high set element.

5.2.7 Relay characteristic angle RCA

The characteristic angle for directional feature in the phase current path can be set by parameter RCA to 15°, 27°, 38°, 49°, 61°, 72° or 83°, leading to the respective reference voltage (see chapter 4.3).

5.2.8 Voltage transformer connection for residual voltage measuring (3pha/e-n/1:1)

Depending on the connection of the voltage transformer of ER/XR-relay types three possibilities of the residual voltage measurement can be chosen (see chapter 4.4)

5.2.9 Pickup value for residual voltage U_E (ER/XR-relay type)

Regardless of the preset earth current, an earth fault is only identified if the residual voltage exceeds the set reference value. This value is indicated in volt.

5.2.10 Pickup current for earth fault element (I_{E_s})

(Similar to chapter 5.2.1)

The pickup value of X and XR-relay type relates to % I_N .

5.2.11 WARN/TRIP changeover (E/X and ER/XR-relay type)

A detected earth fault can be parameterized as follows:

- "warn" only the alarm relay trips
- "TRIP" the trip relay trips and tripping values are stored.

5.2.12 Time current characteristics for earth fault element (CHAR IE; (not for ER/XR-relay type)

(Similar to chapter 5.2.2)

5.2.13 Trip delay or time multiplier for earth fault element ($t_{IE_{>>}}$)

(Similar to chapter 5.2.3)

5.2.14 Reset mode for inverse time tripping in earth current path

(Similar to chapter 5.2.4)

5.2.15 Current setting for high set element of earth fault supervision ($I_{E>}$)

(Similar to chapter 5.2.5)

The pickup value of X and XR-relay type relates to $\% I_N$.

5.2.16 Trip delay for high set element of earth fault supervision ($t_{E>}$)

(Similar to chapter 5.2.6)

5.2.17 COS/SIN Measurement (ER/XR-relay type)

Depending on the neutral earthing connection of the protected system the directional element of the earth fault relay must be preset to $\cos \varphi$ or $\sin \varphi$ measurement.

By pressing <SELECT> the display shows "COS" resp. "SIN". The desired measuring principle can be selected by <+> or <-> and must be entered with password.

5.2.18 SOLI/RESI changeover (SR-relay type)

Depending on the method of neutral-point connection of the system to be protected, the directional element for the earth-current circuit must be set to "SOLI" (= solidly earthed) or "RESI" = (resistance earthed).

5.2.19 Circuit breaker failure protection t_{CBFP}

The CB failure protection is based on supervision of phase currents during tripping events. Only after tripping this protective function becomes active. The test criterion is whether all phase currents are dropped to $<1\% \times I_N$ within t_{CBFP} (Circuit Breaker Failure Protection - adjustable between 0.1 - 1.6s). If not all of the phase currents have dropped to $<1\% \times I_N$ within this time, CB failure is detected and the related relay activated. The CB failure protection function is deactivated again as soon as the phase currents have dropped to $<1\% \times I_N$ within t_{CBFP} .

5.2.20 Nominal frequency

The adapted FFT-algorithm requires the nominal frequency as a parameter for correct digital sampling and filtering of the input currents.

By pressing <SELECT> the display shows "f=50" or "f=60". The desired nominal frequency can be adjusted by <+> or <-> and then stored with <ENTER>.

5.2.21 Display of the activation storage (FLSH/NOFL)

If after an activation the existing current drops again below the pickup value, e.g. $I>$, without a trip has been initiated, LED $I>$ signals that an activation has occurred by flashing fast. The LED keeps flashing until it is reset again (push button <RESET>). Flashing can be suppressed when the parameter is set to NOFL.

5.2.22 Adjustment of the slave address

Pressing push buttons <+> and <-> the slave address can be set in range of 1-32.

5.2.23 Setting of Baud-rate (applies for Modbus Protocol only)

Different transmission rates (Baud rate) can be set for data transmission via Modbus protocol. The rate can be changed by push buttons <+> and <-> and saved by pressing <ENTER>.

5.2.24 Setting of parity (applies for Modbus Protocol only)

The following three parity settings are possible :

- "EVN" = even
- "ODD" = odd
- "NO" = no parity check

The setting can be changed by push buttons <+> and <-> and saved by pressing <ENTER>.

5.2.25 Blocking the protection functions and assignment of the output relays

Blocking the protection functions:

The blocking function of the *MR11* can be set according to requirement. By applying the aux. voltage to D8/E8, the functions chosen by the user are blocked. Setting of the parameter should be done as follows:

- When pressing push buttons <ENTER> and <TRIP> at the same time, message "BLOC" is displayed (i.e. the respective function is blocked) or "NO_B" (i.e. the respective function is not blocked). The LED allocated to the first protection function I> lights red.
- By pressing push buttons <+> <-> the value displayed can be changed.
- The changed value is stored by pressing <ENTER> and entering the password.
- By pressing the <SELECT/RESET> push button, any further protection function which can be blocked is displayed.
- Thereafter the blocking menu is left by pressing <SELECT/RESET> again.

Function		Display	LED/Colour
I>	Overcurrent (Low set)	NO_B	I> yellow
I>>	Overcurrent (High set)	BLOC	I>> yellow
I _{E>}	Earth current 1. element	NO_B	I _{E>} yellow
I _{E>>}	Earth current 2. element	NO_B	I _{E>>} yellow
tCBFPI _{E>>}	Switch failure protection	NO_B	

Table 5.2: Default settings of blocking functions

Assignment of the output relays:

Unit *MR11* has five output relays. The fifth output relay is provided as permanent alarm relay for self supervision is normally on. Output relays 1 - 4 are normally off and can be assigned as alarm or tripping relays to the current functions which can either be done by using the push buttons on the front plate or via serial interface RS485. The assignment of the output relays is similar to the setting of parameters, however, only in the assignment mode. The assignment mode can be reached only via the blocking mode.

By pressing push button <SELECT/RESET> in blocking mode again, the assignment mode is selected.

The relays are assigned as follows: LEDs I>, I>>, I_{E>}, I_{E>>} are two-coloured and light up **green** when the output relays are assigned as **alarm relays** and **red** as **tripping relays**.

In addition, the LED →← also lights up with each adjustment. Green means advance and red reverse direction.

Definition:

Alarm relays are activated at pickup.

Tripping relays are only activated after elapse of the tripping delay.

After the assignment mode has been activated, first LED I> lights up green. Now one or several of the four output relays can be assigned to current element I> as alarm relays. At the same time the selected alarm relays for frequency element 1 are indicated on the display. Indication "1 _ _ _" means that output relay 1 is assigned to this current element. When the display shows " _ _ _ _", no alarm relay is assigned to this current element. The assignment of output relays 1 - 4 to the current elements can be changed by pressing <+> and <-> push buttons. The selected assignment can be stored by pressing push button <ENTER> and subsequent input of the password. By pressing push button <SELECT/RESET>, LED I> lights up red. The output relays can now be assigned to this current element as tripping relays.

Relays 1 - 4 are selected in the same way as described before. By repeatedly pressing of the <SELECT/RESET> push button and assignment of the relays all elements can be assigned separately to the relays. The assignment mode can be terminated at any time by pressing the <SELECT/RESET> push button for some time (abt. 3 s).

Note:

- The function of jumper J2 described in general description "MR Digital Multifunctional Relays" has no function. For relays without assignment mode this jumper is used for parameter setting of alarm relays (activation at pickup or tripping).
- A form is attached to this description where the setting requested by the customer can be filled-in. This form is prepared for telefax transmission and can be used for your own reference as well as for telephone queries.

Relay function		Output relays				Display-indication	Lighted LED
		1	2	3	4		
l> (V)	alarm		X			_ 2 _ _	l>; →← green
tl> (V)	tripping	X				1 _ _ _	t<_i; →← green
l>> (R)	alarm		X			_ 2 _ _	l>>; →← red
tl>> (R)	tripping	X				1 _ _ _	t<_i; →← red
l>> (V)	alarm			X		_ _ 3 _	l>>_i; →← green
tl>> (V)	tripping	X				1 _ _ _	t<_E>>i; →← green
l>> (R)	alarm			X		_ _ 3 _	l>>_i; →← red
tl>> (R)	tripping	X				1 _ _ _	t<_E>>i; →← red
lE> (V)	alarm				X	_ _ _ 4	lE>_i; →← green
tlE> (V)	tripping	X				1 _ _ _	t<_E>_i; →← green
lE> (R)	alarm				X	_ _ _ 4	lE>_i; →← red
tlE> (R)	tripping	X				1 _ _ _	t<_E>_i; →← red
lE>> (V)	alarm				X	_ _ _ 4	lE>>_i; →← green
tlE>> (V)	tripping	X				1 _ _ _	t<_E>>i; →← green
lE>> (R)	alarm				X	_ _ _ 4	lE>>_i; →← red
tlE>> (R)	tripping	X				1 _ _ _	t<_E>>i; →← red
tCBFP	tripping					_ _ _ _	

(V) = advance direction;
(R) = reverse direction

This way, a tripping relay can be set for each activation and tripping direction.

Table 5.3: Example of assignment matrix of the output relay (default settings).

5.3 Setting value calculation

5.3.1 Definite time overcurrent element

Low set element I>

The pickup current setting is determined by the load capacity of the protected object and by the smallest fault current within the operating range. The pickup current is usually selected about 20% for power lines, about 50% for transformers and motors above the maximum expected load currents.

The delay of the trip signal is selected with consideration to the demand on the selectivity according to system time grading and overload capacity of the protected object.

High set element I>>

The high set element is normally set to act for near-by faults. A very good protective reach can be achieved if the impedance of the protected object results in a well-defined fault current. In case of a line-transformer combination the setting values of the high set element can even be set for the fault inside the transformer. The time delay for high set element is always independent to the fault current.

5.3.2 Inverse time overcurrent element

Beside the selection of the time current characteristic one set value each for the phase current path and earth current path is adjusted.

Low set element I>

The pickup current is determined according to the maximum expected load current. For example:

Current transformer ratio: 400/5A

Maximum expected load current: 300A

Overload coefficient: 1.2 (assumed)

Starting current setting:

$$I_s = (300/400) \times 1.2 = 0.9 \times I_N$$

Time multiplier setting

The time multiplier setting for inverse time overcurrent is a scale factor for the selected characteristics. The characteristics for two adjacent relays should have a time interval of about 0.3 - 0.4 s.

High set element I>>

The high set current setting is set as a multiplier of the nominal current. The time delay tI>> is always independent to the fault current.

5.4 Indication of measuring and fault values

5.4.1 Indication of measuring values

The following measuring quantities can be indicated on the display during normal service:

- Apparent current in phase 1 (LED L1 green)
- Active current in Phase 1 (LED L1 and I_p green) *
- Reactive current in Phase 1 (LED L1 and I_Q green) *
- Apparent current in phase 2 (LED L2 green)
- Active current in Phase 2 (LED L2 and I_p green) *
- Reactive current in Phase 2 (LED L2 and I_Q green) *
- Apparent current in phase 3 (LED L3 green)
- Active current in Phase 3 (LED L3 and I_p green) *
- Reactive current in Phase 3 (LED L3 and I_Q green) *
- Apparent earth current (LED E green)
- Active earth current (LED E and I_p green) *
- Reactive earth current (LED E and I_Q green) *
- Residual voltage UR (LED U_E) only at ER/XR-relay type
- Angle between I_E and U_E

* only in case that the directional option is built in.

The indicated current measuring values refer to nominal current. (For *MR11-XR/X* relays the indicated measuring values refer to % of I_N)

5.4.2 Indication of fault data

All faults detected by the relay are indicated on the front plate optically. For this purpose, the four LEDs (L1, L2, L3, E) and the four function LEDs (I>, I>>, IE>, IE>> and →←) are equipped at *MR11*. If, for example an overcurrent occurs, first the corresponding phases will light up. LED I> lights up at the same time. After tripping the LEDs are lit permanently.

5.4.3 Fault memory (not for ER/XR types)

When the relay is energized or trips, all fault data are stored in a non-volatile memory manner. The *MR11* is provided with a fault value recorder for max. eight fault occurrences. In the event of additional trippings always the oldest data set is written over.

For fault indication not only the trip values are recorded but also the status of LEDs. Fault values are indicated when push buttons <-> or <+> are pressed during normal measuring value indication.

- Normal measuring values are selected by pressing the <SELECT/RESET> button.
- When then the <-> button is pressed, the latest fault data set is shown. By repeated pressing the <-> button the last but one fault data set is shown etc. For indication of fault data sets abbreviations FLT1, FLT2, FLT3, ... are displayed (FLT1 means the latest fault data set recorded).
- By pressing <SELECT/RESET> the fault measuring values can be scrolled.
- By pressing <+> it can be scrolled back to a more recent fault data set. At first FLT8, FLT7, ... are always displayed. When fault recording is indicated (FLT1 etc), the LEDs flash in compliance with the stored trip information, i.e. those LEDs which showed a continuous light when the fault occurred are now blinking to indicate that it is not a current fault. LEDs which were blinking during trip conditions, (element had picked up) just briefly flash.
- If the relay is still in trip condition and not yet reset (TRIP is still displayed), no measuring values can be shown.
- To delete the trip store, the push button combination <SELECT/RESET> and <-> has to be pressed for about 3s. The display shows 'wait'.

Recorded fault values:

Value displayed	Relevant LED
Phase currents L1, L2, L3 in I/I _N	L1, L2, L3
Earth current I _E in I/I _N	E
C.B. switching time in s ¹⁾	C.B.
Expired tripping time of I> in % of t _b ²⁾	I>
Expired tripping time of I _{E>} in % of t _{E>} ²⁾	I _{E>}

¹⁾ C.B. switching time:
Time between energizing of the trip output relay and switching of the C.B. (current < 1 % I_N).

²⁾ Expired tripping time:
Time between pickup and release of the low set element. This value is only displayed for I> and I_{E>}.

5.5 Reset

Unit *MR11* has the following three possibilities to reset the display of the unit as well as the output relay at jumper position J3=ON.

Manual Reset

- Pressing the push button <SELECT/RESET> for some time (about 3 s)

Electrical Reset

- Through applying auxiliary voltage to C8/D8

Software Reset

- The software reset has the same effect as the <SELECT/RESET> push button (see also communication protocol of RS485 interface).

The display can only be reset when the pickup is not present anymore (otherwise "TRIP" remains in display). During resetting of the display the parameters are not affected.

6 Relay testing and commissioning

The test instructions following below help to verify the protection relay performance before or during commissioning of the protection system. To avoid a relay damage and to ensure a correct relay operation, be sure that:

- the auxiliary power supply rating corresponds to the auxiliary voltage on site.
- the rated current and rated voltage of the relay correspond to the plant data on site.
- the current transformer circuits and voltage transformer circuits are connected to the relay correctly.
- all signal circuits and output relay circuits are connected correctly.

6.1 Power-On

NOTE!

Prior to switch on the auxiliary power supply, be sure that the auxiliary supply voltage corresponds with the rated data on the type plate.

Switch on the auxiliary power supply to the relay and check that the message "ISEG" appears on the display and the self supervision alarm relay (watchdog) is energized (Contact terminals D7 and E7 closed).

6.2 Testing the output relays and LEDs

NOTE!

Prior to commencing this test, interrupt the trip circuit to the circuit breaker if tripping is not desired.

By pressing the push button <TRIP> once, the display shows the first part of the software version of the relay (e.g. "D08-"). By pressing the push button <TRIP> twice, the display shows the second part of the software version of the relay (e.g. "4.01"). The software version should be quoted in all correspondence. Pressing the <TRIP> button once more, the display shows "PSW?". Please enter the correct password to proceed with the test. The message "TRI?" will follow. Confirm this message by pressing the push button <TRIP> again. All output relays should then be activated and the self supervision alarm relay (watchdog) be deactivated one after another with a time interval of 3 second and all LEDs with a delay of 0.5 seconds, with the self-supervision relay dropping. Thereafter, reset all output relays back to their normal positions by pressing the push button <SELECT/RESET> (about 3 s).

6.3 Checking the set values

By repeatedly pressing the push button <SELECT>, all relay set values may be checked. Set value modification can be done with the push button <+><-> and <ENTER>. For detailed information about that, please refer to chapter 5.

For a correct relay operation, be sure that the frequency set value ($f=50/60$) has been selected according to your system frequency (50 or 60 Hz).

6.4 Secondary injection test

6.4.1 Test equipment

- Voltmeter, Ammeter with class 1 or better
- Auxiliary power supply with the voltage corresponding to the rated data on the type plate
- Single-phase current supply unit (adjustable from 0 to $\geq 4 \times I_n$)
- Single-phase voltage supply unit (adjustable from 0 to $\geq 1.2 \times U_n$) (Only for relays with directional feature)
- Timer to measure the operating time (Accuracy class $\leq \pm 10$ ms)
- Switching device
- Test leads and tools

6.4.2 Example of test circuit for MRI1 relays without directional feature

For testing MRI1 relays without directional feature, only current input signals are required. Figure 6.1 shows a simple example of a single phase test circuit with adjustable current energizing the MRI1 relay under test.

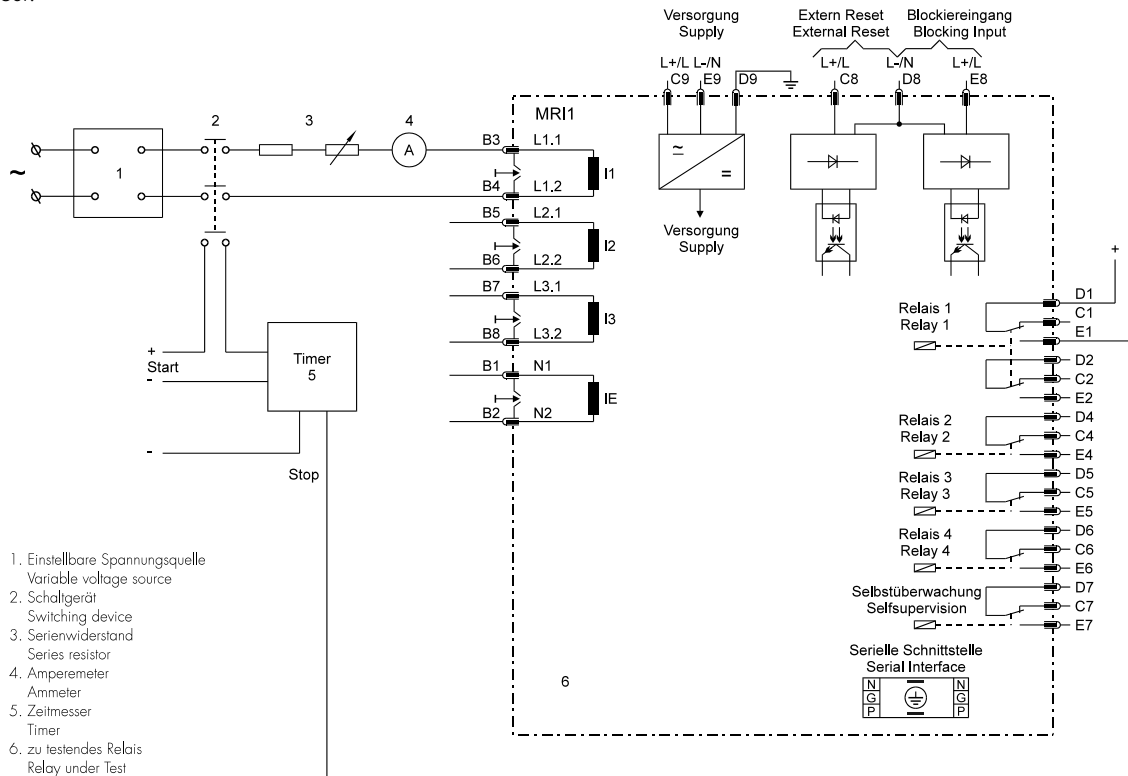


Figure 6.1: Test circuit

6.4.3 Checking the input circuits and measured values

Inject a current, which is less than the relay pickup current set values, in phase 1 (terminals B3-B4), and check the measured current on the display by pressing the push button <SELECT>. For a relay with rated current $I_n = 5A$, for example, a secondary current injection of 1A should be indicated on the display with about 0.2 ($0.2 \times I_n$). The current can be also injected into the other current input circuits (Phase 2: terminals B5-B6, Phase 3: terminals B7-B8). Compare the displayed current value with the reading of the ammeter. The deviation must not exceed 3% or 1% I_n . By using an RMS-metering instrument, a greater deviation may be observed if the test current contains harmonics. Because the MRI1 relay measures only the fundamental component of the input signals, the harmonics will be rejected by the internal DFFT-digital filter. Whereas the RMS-metering instrument measures the RMS-value of the input signals.

6.4.4 Checking the operating and resetting values of the relay

Inject a current which is less than the relay set values in phase 1 of the relay and gradually increase the current until the relay starts, i.e. at the moment when the LED $I_>$ and $L1$ light up or the alarm output relay $I_>$ is activated. Read the operating current indicated by the ammeter. The deviation must not exceed 3% of the set operating value or 1% I_n . Furthermore, gradually decrease the current until the relay resets, i.e. the alarm output relay $I_>$ is disengaged. Check that the resetting current is smaller than 0.97 times the operating current. Repeat the test on phase 2, phase 3 and earth current input circuits in the same manner. (Accuracy of earth current measuring $\pm 3\%$ of measuring value or 0.1% of I_n for E-type; 0.01% of I_n for X-type).

6.4.5 Checking the relay operating time

To check the relay operating time, a timer must be connected to the trip output relay contact. The timer should be started simultaneously with the current injection in the current input circuit and stopped by the trip relay contact. Set the current to a value corresponding to twice the operating value and inject the current instantaneously. The operating time measured by the timer should have a deviation of less than 3% of the set value or ± 10 ms (DEFT). Accuracy for inverse time characteristics refer to IEC 255-3.

Repeat the test on the other phases or with the inverse time characteristics in the similar manner.

In case of inverse time characteristics the injected current should be selected according to the characteristic curve, e.g. two times I_s . The tripping time may be read from the characteristic curve diagram or calculated with the equations given under "technical data".

Please observe that during the secondary injection test the test current must be very stable, not deviating more than 1%. Otherwise the test results may be wrong.

6.4.6 Checking the high set element of the relay

Set a current above the set operating value of $I_{>>}$. Inject the current instantaneously and check that the alarm output relay $I_{>>}$ operates. Check the tripping time of the high set element according chapter 6.4.5. Check the accuracy of the operating current setting by gradually increasing the injected current until the $I_{>>}$ element picks up. Read the current value from the ammeter and compare with the desired setting. Repeat the entire test on other phases and earth current input circuits in the same manner.

Note !

Where test currents $> 4 \times I_N$ are used, the thermal withstand capability of the current paths has to be considered (see technical data, chapter 7.1).

6.4.7 Example of a test circuit for MRI1 relay with directional feature

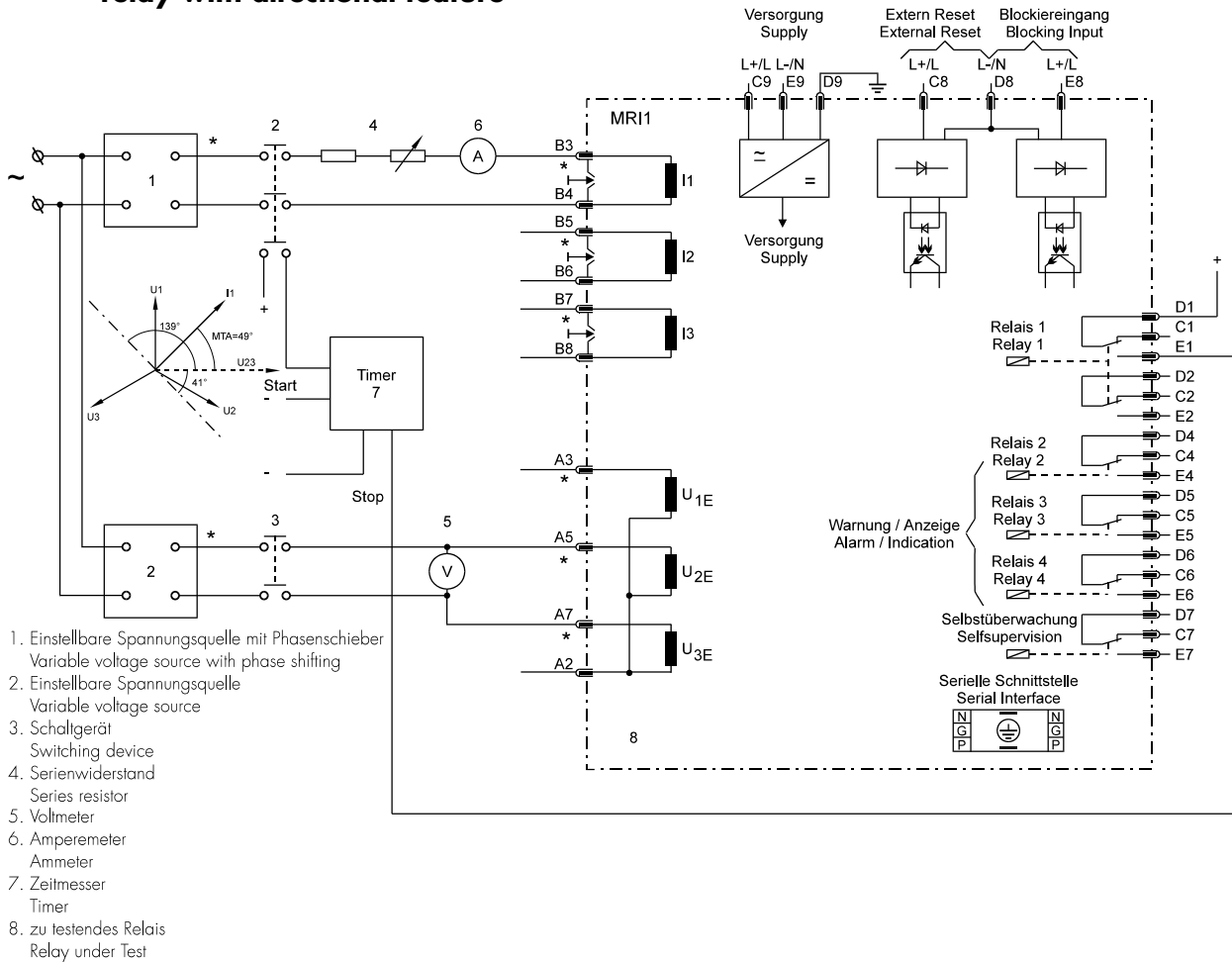


Figure 6.2: Test circuit

For testing relays with directional feature, current and voltage input signals with adjustable phase shifting are required. Figure 6.2 shows an example of a single phase test circuit with adjustable voltage and current energizing the **MRI1** relay under test.

For testing a relay with directional feature, one of the input energizing quantity (voltage) shall be applied to the relay with a constant value within its effective range. The other input energizing quantity (current) and phase angle shall be appropriately varied.

MRI1 is a three phase directional time overcurrent relay with relay connection angle of 0° . The relay input currents and their corresponding reference voltages are shown in the following table (refer to 4.3):

If the single phase test circuit as illustrated in Figure 6.2 is applied to test the directional feature of the relay and the current source is connected to phase 1 current input (B3/B4), then the voltage source should be connected to relay terminals A5/A7.

In order to test the directional feature, all activation points should first be set to "EXIT". Then a test voltage equivalent to the rated voltage is connected to terminals A5/A7 and a current of $1 \times I_n$ is impressed upon the current inputs B3/B4.

It is now possible to read and check all measured values in accordance with Table 6.1. If the phase position is changed, the values I_Q and I_P change. If the angle is changed by 90° , for example, the measured value for current input I1 must be 1.0 for I_P and ± 0.0 for I_Q .

Determining the change in direction

The angle of greatest sensitivity for determining the phase direction is adjustable between 15° and 83° . Consequently, the greatest sensitivity is achieved with setting 49° if the input current leads the input voltage by 49° . This setting results in a tripping range in advance direction of 139° leading to 41° lagging if the marginal regions are neglected on account of lack in measuring precision.

Current input	Terminals	Reference voltage	Terminals	Display		
				Phase	I_p	I_Q
	S2/S1		L/N			
I1	B3/B4	U23	A5/A7	1.00 ±3%	±0.0 ±3% I _n	+1.0 ±3% I _n
I2	B5/B6	U31	A3/A7	1.00 ±3%	±0.0 ±3% I _n	+1.0 ±3% I _n
I3	B7/B8	U12	A3/A5	1.00 ±3%	±0.0 ±3% I _n	+1.0 ±3% I _n
E*	B1/B2	U1	A3/A2	1.00 ±5%	+1.0 ±5% I _n	±0.0 ±5% I _n

* Only SR-Types

Table 6.1

In order to check this, the following parameters should be set:

Parameter	Setting
I>	0,5 x I _n
tl> (V)	EXIT
tl> (R)	EXIT
IE>	0,5 x I _n
tlE> (V)	EXIT
tlE> (R)	EXIT

for relay assignment:

Parameter	Relays
I> Alarm (V)	_2_
I> Alarm (R)	_3_
IE> Alarm (V)	_2_
IE> Alarm (R)	_3_

A test current of 1 x I_n is impressed upon the current input. The voltage source is to be connected as provided for in Table 6.1. With an angle setting of 49° leading, relay 2 must respond and LED →← lights up green. If the angle is now changed beyond the marginal regions, the LED →← changes from green to red. Relay 2 drops and relay 3 responds. This test must be repeated for current inputs 12 and 13.

In order to determine the direction in the earth current circuit (SR version) refer to Fig. 8 with the characteristic angle in the rigid grid (SOLI) and to Fig. 9 with the characteristic angle in the grid with resistance earthing (RESI).

To check the trip delays for forward and backward direction they have to be set differently, because there's only one trip relay for both directions.

Great care must be taken to connect the test current and test voltage to the relay in correct polarity. In Figure 6.2 the relay and test source polarity are indicated by a * mark near the terminals. The markings indicate that the relay will trip in its maximum sensitive angle when the voltage drop from the marked end to the non-marked end in the voltage input circuit has 49° phase angle lagging the current flowing from the marked end to the non-marked in the current input circuit. Of course, regardless of polarity, the current level must be above the pickup value.

6.4.8 Test circuit earth fault directional feature

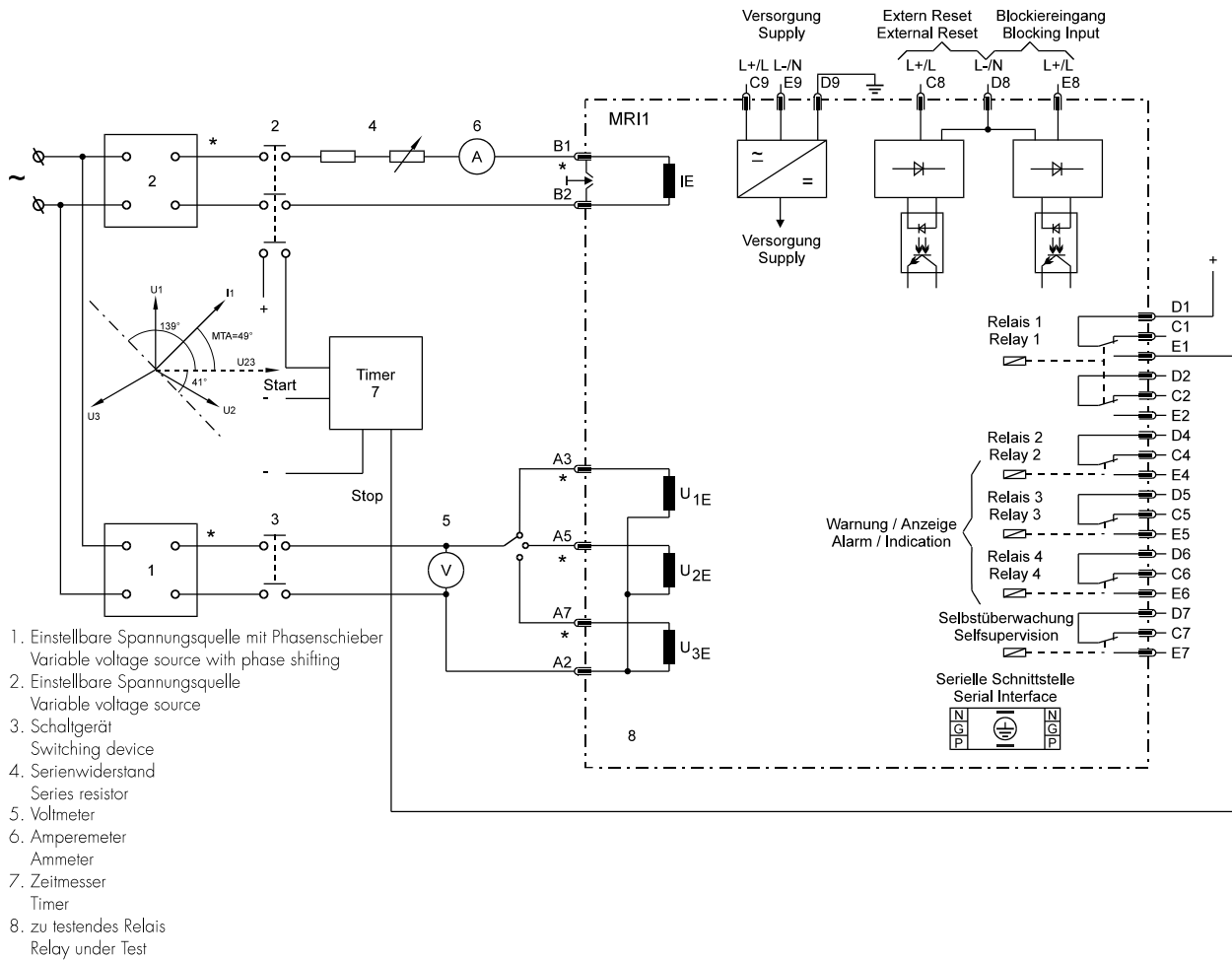


Figure 6.3: Test circuit

For testing relays with earth fault directional feature, current and voltage input signals with adjustable phase shifting are required. Figure 6.3 shows an example of a single phase test circuit with adjustable voltage and current energizing the **MRI1** relay under test.

For testing a relay with earth fault directional feature, one of the input energizing quantity (voltage) shall be applied to the relay with a constant value within its effective range. The other input energizing quantity (current) and phase angle shall be appropriately varied.

With the aid of phase angle indicated on the display the correct function of the relay can be checked (ER-relay type).

Parameters $I_{E>}$ and $I_{E>>}$ should be set to EXIT.

The following measured values are shown:

Measured value	LED
Earth current	$E, I_{E>}$
Active share	E, I_p
reactive share	E, I_Q
Earth voltage	$E, U_{E>}$
Angel	$E, I_{E>}, U_{E>}$

6.4.9 Checking the external blocking and reset functions

The external blocking input inhibits e. g. the function of the high set element of the phase current. To test the blocking function apply auxiliary supply voltage to the external blocking input of the relay (terminals E8/D8). The time delay t_{b} should be set to EXIT for this test. Inject a test current which could cause a high set ($I_{\text{h}} >>$) tripping. Observe that there is no trip and alarm for the high set element.

Remove the auxiliary supply voltage from the blocking input. Inject a test current to trip the relay (message "TRIP" on the display). Interrupt the test current and apply auxiliary supply voltage to the external reset input of the relay (terminals C8/D8). The display and LED indications should be reset immediately.

6.4.10 Test of the CB failure protection

For testing the tripping time a test current of about 2 times the rated current to be injected. The timer is started upon tripping of the relay of a protection function (I_{h} , $I_{\text{h}} >>$, I_{E} , $I_{\text{E}} >>$) and stopped as soon as the relay for the CB failure protection has picked up. Message "CBFP" is displayed. The tripping time ascertained by the timer should not deviate more than 1% or, at short trip delay, less than 10 ms from the set tripping time.

Alternatively, the timer can be started when the aux. voltage and the test current are injected simultaneously. The timer stops when the corresponding output relay for circuit breaker failure protection trips. In this case the previously measured tripping delay (see section 6.4.5) has to be subtracted from the total tripping time measured.

6.5 Primary injection test

Generally, a primary injection test could be carried out in the similar manner as the secondary injection test described above. With the difference that the protected power system should be, in this case, connected to the installed relays under test "on line", and the test currents and voltages should be injected to the relay through the current and voltage transformers with the primary side energized. Since the cost and potential hazards are very high for such a test, primary injection tests are usually limited to very important protective relays in the power system.

Because of its powerful combined indicating and measuring functions, the **MR11** relay may be tested in the manner of a primary injection test without extra expenditure and time consumption.

In actual service, for example, the measured current values on the **MR11** relay display may be compared phase by phase with the current indications of the ammeter of the switchboard to verify that the relay works and measures correctly. In case of a **MR11** relay with directional feature, the active and reactive parts of the measured currents may be checked and the actual power factor may be calculated and compared it with the $\cos\phi$ -meter indication on the switchboard to verify that the relay is connected to the power system with the correct polarity.

6.6 Maintenance

Maintenance testing is generally done on site at regular intervals. These intervals vary among users depending on many factors: e.g. the type of protective relays employed; the importance of the primary equipment being protected; the user's past experience with the relay, etc.

For electromechanical or static relays, maintenance testing will be performed at least once a year according to the experiences. For digital relays like **MR11**, this interval can be substantially longer. This is because:

- the **MR11** relays are equipped with very wide self-supervision functions, so that many faults in the relay can be detected and signalized during service. Important: The self-supervision output relay must be connected to a central alarm panel!
- the combined measuring functions of **MR11** relays enable supervision the relay functions during service.
- the combined TRIP test function of the **MR11** relay allows to test the relay output circuits.

A testing interval of two years for maintenance will, therefore, be recommended.

During a maintenance test, the relay functions including the operating values and relay tripping characteristics as well as the operating times should be tested.

7 Technical data

7.1 Measuring input circuits

Rated data:	Nominal current I_N	1 A or 5 A
	Nominal voltage U_N	100 V, 230 V, 400 V
	Nominal frequency f_N	50 Hz; 60 Hz adjustable
Power consumption in current circuit:	at $I_N = 1$ A	0.2 VA
	at $I_N = 5$ A	0.1 VA
Power consumption in voltage circuit:		< 1 VA
Thermal withstand capability in current circuit:	dynamic current withstand (half-wave)	$250 \times I_N$
	for 1 s	$100 \times I_N$
	for 10 s	$30 \times I_N$
	continuously	$4 \times I_N$
Thermal withstand in voltage circuit:	continuously	$1.5 \times U_N$

7.2 Common data

Dropout to pickup ratio:	> 97 %
Returning time :	30 ms
Time lag error class index E:	± 10 ms
Minimum operating time:	30 ms
Transient overreach at instantaneous operation:	≤ 5 %
Influences on the current measurement	
Auxiliary voltage:	in the range of $0.8 < U_H / U_{HN} < 1.2$ no additional influences can be measured
Frequency:	in the range of $0.9 < f/f_N < 1.1$; < 0.2 % / Hz
Harmonics:	up to 20 % of the third harmonic; < 0.08 % per percent of the third harmonic up to 20 % of the fifth harmonic; < 0.07 % per percent of the fifth harmonic
Influences on delay times:	no additional influences can be measured

7.3 Setting ranges and steps

7.3.1 Time overcurrent protection (I-Type)

	Setting range	Step	Tolerance
$I_{>}$	$0.2 \dots 6.0 \times I_N$	$0.01; 0.02; 0.05; 0.1 \times I_N$	$\pm 3\%$ from set value or min. $\pm 2\% I_N$
$t_{I>}$	$0.03 - 260$ s (definite time) $0.05 - 10$ (inverse time)	$0.01; 0.02; 0.05; 0.1; 0.2; 0.5; 1.0; 2.0;$ $5.0; 10; 20$ s $0.01; 0.02; 0.05; 0.1; 0.2$	$\pm 3\%$ or ± 10 ms $\pm 3\%$ of the measuring value of the current or ± 20 ms (see EN60255-3)
$I_{>>}$	$1 \dots 40 \times I_N$	$0.1; 0.2; 0.5; 1.0 \times I_N$	$\pm 3\%$ from set value or min. $\pm 2\% I_N$
$t_{I>>}$	$0.03 \dots 2$ s	0.01 s; 0.02 s; 0.05 s	$\pm 3\%$ or ± 10 ms

7.3.2 Earth fault protection (SR-Type)

	Setting range	Step	Tolerance
$I_{E>}$	$0.01 \dots 2.0 \times I_N$ (EXIT)	$0.001; 0.002; 0.005; 0.01; 0.02; 0.05 \times I_N$	$\pm 5\%$ from set value or $\pm 0.3\% I_N$
$t_{E>}$	$0.03 - 260$ s (EXIT) (definite time) $0.05 - 10$ (EXIT) (inverse time)	$0.01; 0.02; 0.05; 0.1; 0.2; 0.5; 1.0; 2.0;$ $5.0; 10; 20$ s $0.01; 0.02; 0.05; 0.1; 0.2$	$\pm 3\%$ or ± 20 ms $\pm 3\%$ of the measuring value of the current or ± 20 ms (see EN60255-3)
$I_{E>>}$	$0.01 \dots 1.5 \times I_N$ (EXIT)	$0.001; 0.002; 0.005; 0.01; 0.02; 0.05; 0.1;$ $0.2; 0.5 \times I_N$	$\pm 5\%$ from set value
$t_{E>>}$	$0.03 \dots 2.0$ s (EXIT)	0.01 s; 0.02 s; 0.05 s	$\pm 3\%$ or ± 20 ms

7.3.3 Earth fault protection (E/X-Type)

	Setting range	Step	Tolerance
$I_{E>}$	$0.01 \dots 2.0 \times I_N$ (EXIT) (E) $0.1 \dots 20\% I_N$ (EXIT) (X)	$0.001; 0.002; 0.005; 0.01; 0.02; 0.05 \times$ I_N	$\pm 5\%$ from set value or $\pm 0.3\% I_N$ (E); $\pm 0.03\% I_N$ (X)
$t_{E>}$	$0.03 - 260$ s (EXIT) (E) $0.04 \dots 260$ s (EXIT) (X) (definite time) $0.05 \dots 10$ (EXIT) (E) $0.06 \dots 10$ (EXIT) (X) (inverse time)	$0.01; 0.02; 0.05\% I_N$ $0.01; 0.02; 0.05; 0.1; 0.2; 0.5; 1.0; 2.0;$ $5.0; 10; 20$ s $0.01; 0.02; 0.05; 0.1; 0.2$	$\pm 3\%$ or ± 20 ms $\pm 3\%$ of the measuring value of the current or ± 20 ms (see EN60255-3)
$I_{E>>}$	$0.01 \dots 15.0 \times I_N$ (E)	$0.001; 0.002; 0.005; 0.01; 0.02; 0.05$ $0.1; 0.2; 0.5 \times I_N$	$\pm 5\%$ from set value or $\pm 0.3\% I_N$ (E); $\pm 0.03\% I_N$ (X)
$t_{E>>}$	$0.1 \dots 150\% I_N$ (EXIT) (X) $0.03 \dots 2.0$ s (EXIT) (E) $0.04 \dots 2.0$ s (EXIT) (X)	$0.01; 0.02; 0.05\% I_N$ 0.01 s; 0.02 s; 0.05 s	$\pm 3\%$ or ± 20 ms

7.3.4 Earth fault protection (ER/XR-Type)

	Setting range	Step	Tolerance
$I_{E>}$ $t_{IE>}$	0.01...0.45 x I_N (EXIT) (ER) 0.1...4.5% I_N (EXIT) (XR) 0.05 - 260 s (definite time)	0.001; 0.002; 0.005; 0.01 x I_N 0.01%; 0.02%; 0.05%; 0.1% x I_N 0.01; 0.02; 0.05; 0.1; 0.2; 0.5; 1.0; 2.0; 5.0; 10; 20 s	$\pm 5\%$ from set value or $\pm 0.3\%$ I_N (ER); $\pm 0.03\%$ I_N (XR) $\pm 3\%$ or ± 15 ms
$I_{E>>}$ $t_{IE>>}$	0.01...0.45 x I_N (EXIT) (ER) 0.1...4.5% I_N (EXIT) (XR) 0.05...2.0 s	0.001; 0.002; 0.005; 0.01x I_N 0.01%; 0.02%; 0.05%; 0.1% x I_N 0.01 s; 0.02 s; 0.05 s	$\pm 5\%$ from set value or $\pm 0.3\%$ I_N (ER); $\pm 0.03\%$ I_N (XR) $\pm 3\%$ or ± 15 ms
$U_{E>}$	$U_N = 100$ V: 3 PHA/e-n: 1 - 70 V 1:1: 1 - 120 V $U_N = 230$ V: 3 PHA/e-n: 2 - 160 V 1:1: 2 - 300 V $U_N = 400$ V: 3 PHA/e-n: 5 - 300 V 1:1: 5 - 500 V	1 V 1 V 2 V 2 V 5 V 5 V	$\pm 5\%$ from set value or < 0.5% U_N

7.3.5 Switch failure protection

t_{CBFP}	t_{CBFP}	0,1...2,0 s; EXIT	0,01; 0,02; 0,05; 0,1 s	$\pm 1\%$ bzw. ± 10 ms
------------	------------	-------------------	-------------------------	----------------------------

7.3.6 Interface parameter

Function	Parameter	Modbus-Protocol	RS485 Open Data Protocol
RS	Slave-Address	1 - 32	1 - 32
RS	Baud-Rate*	1200, 2400, 4800, 9600	9600 (fixed)
RS	Parity*	even, odd, no	"even Parity" (fixed)

* only Modbus Protocol

7.3.7 Inverse time overcurrent protection relay

According to IEC 255-4 or BS 142

$$\text{Normal Inverse} \quad t = \frac{0,14}{\left(\frac{I}{I_s}\right)^{0,02} - 1} t_1 > [s]$$

$$\text{Very Inverse} \quad t = \frac{13,5}{\left(\frac{I}{I_s}\right) - 1} t_1 > [s]$$

$$\text{Extremely Inverse} \quad t = \frac{80}{\left(\frac{I}{I_s}\right)^2 - 1} t_1 > [s]$$

Where: t = tripping time
 t_1 = time multiplier
 I = fault current
 I_s = Starting current

7.3.8 Direction unit for phase overcurrent relay

Directional sensitivity for voltage input circuit: $< 0.025 \% U_N$ (phase-to-phase voltage) at $I = 1 \times I_N$
 Connection angle: 90°
 Characteristic angle: $15^\circ, 27^\circ, 38^\circ, 49^\circ, 61^\circ, 72^\circ, 83^\circ$
 Effective angle: $\pm 78^\circ$ related to relay characteristic angle at U_N

7.3.9 Determination of earth fault direction (MRI1-ER/XR)

Measurement of active current component for compensated systems: $I_E \times \cos \varphi$
 Measurement of reactive current component for isolated systems: $I_E \times \sin \varphi$
 Angle measuring accuracy: $\pm 3^\circ$ at $I_E \times \cos \varphi$ or $I_E \times \sin \varphi > 5 \% I_E$

7.3.10 Determination of earth fault direction (MRI1-SR)

Characteristic angle: "SOLI" setting - 110°
 "RESI" setting - 170°
 Effective angle: $\pm 70^\circ$ related to relay characteristic angle at $U_N / \sqrt{3}$
 Residual voltage sensitivity: $< 0.2 \% U_N$ at $I = 0.1 \times I_N$

7.4 Inverse time characteristics

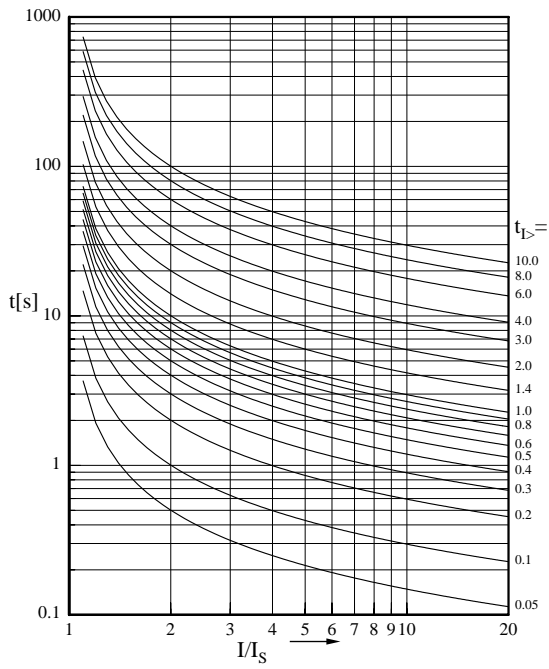


Figure 7.1: Normal Inverse

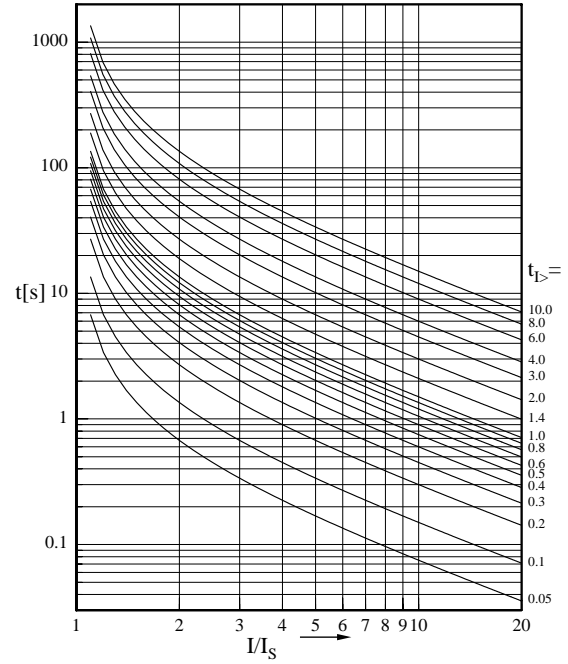


Figure 7.3: Very Inverse

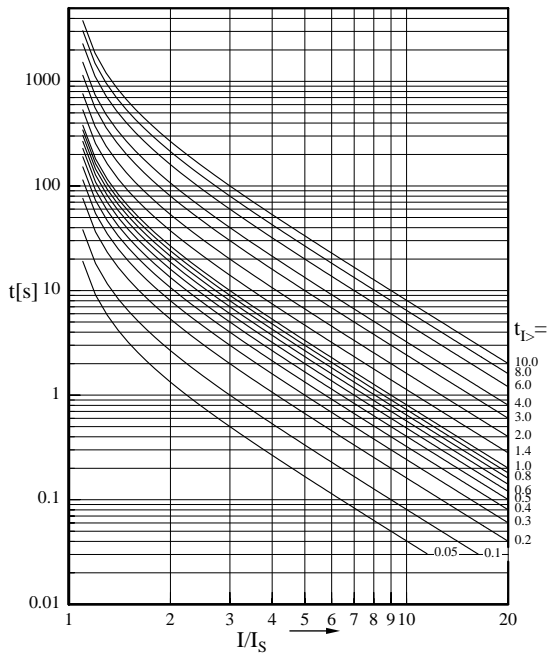


Figure 7.2: Extremely Inverse

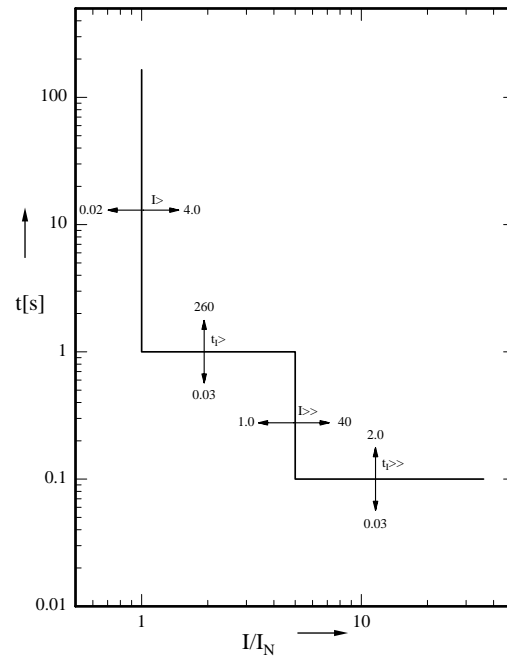


Figure 7.4 Definite time overcurrent relay

7.5 Output contacts

Number of relays: dependent on relay type
 Contacts: 2 change-over contacts for trip relay
 1 change-over contact for alarm relays

Technical data subject to change without notice!

8 Order form

Time overcurrent relay MRI1-		I				
3-phase measuring $I_{>}$, $I_{>>}$						
Rated current	1 A	1				
	5 A	5				
Phase fault directional feature			R			
Rated voltage	100 V			1		
	230 V			2		
	400 V			4		
Housing (12TE)	19"-rack				A	
	Flush mounting				D	
RS485 col	Alternatively with Modbus Protocol					-M

Earth fault current relay MRI1-						
Earth current measuring	standard		E			
	very sensitive		X			
Rated current in earth circuits	1 A			1		
	5 A			5		
Housing (12TE)	19"-rack				A	
	Flush mounting				D	
RS485	Alternatively with Modbus Protocol					-M

Earth fault current relay with directional feature MRI1-			R			
Earth current measuring	for solidly grounded systems	S				
	for isolated/compensated systems	E				
	very sensitive for isolated/compensated systems	X				
Rated current in earth circuits	1 A			1		
	5 A			5		
Directional feature in earth path						
Rated voltage in earth circuits	100 V			1		
	230 V			2		
	400 V			4		
Housing (12TE)	19"-rack				A	
	Flush mounting				D	
RS485 col	Alternatively with Modbus Protocol					-M

Combinated time overcurrent and earth fault current relay

MRI1-		I							
3-phase measuring $I>$, $I>>$									
Rated current	1 A	1							
	5 A	5							
Phase fault directional feature			R						
Rated voltage	100 V			1					
	230 V			2					
	400 V			4					
Earth current measuring	standard					E			
	very sensitive					X			
Rated current in earth circuits	1 A						1		
	5 A						5		
Housing (12TE)	19"-rack							A	
	Flush mounting							D	
RS485	Alternatively with Modbus Protocol								-M

Combinated time overcurrent and earth fault current relay with earth current directional feature

MRI1-		I					R		
3-phase measuring $I>$, $I>>$									
Rated current	1 A	1							
	5 A	5							
Phase fault directional feature			R						
Rated voltage	100 V			1					
	230 V			2					
	400 V			4					
Earth current measuring for	- solidly grounded systems					S			
	- isolated/compensated systems					E			
	-very sensitive for isolated/compensated systems					X			
Rated current in earth circuits	1 A						1		
	5 A						5		
Directional feature in earth path									
Rated voltage in earth circuit	100 V							1	
	230 V							2	
	400 V							4	
Housing (12TE)	19"-rack							A	
	Flush mounting							D	
Rs 485	Alternatively with Modbus Protocol								-M

Setting list MRI1

Note !

All settings must be checked at site and should the occasion arise, adjusted to the object / item to be protected.

Project: _____

SEG job.-no.: _____

Function group: ≙ _____

Location: ± _____

Relay code: - _____

Relay functions: _____

Password: _____

Date: _____

Relay type MRI1-	I	IE IX	IRE IRX	IR	IER IXR	IRER IRXR	ER XR	E X	ISR	IRSR	SR	Default settings	Actual settings
I>	X	X	X	X	X	X			X	X		$0.2 \times I_N$	
CHAR I>	X	X	X	X	X	X			X	X		DEFT	
$t_{I>V}/t_{I>R}$	X	X	X	X	X	X			X	X		0.03 s	
0s / 60 s (phase)	X	X	X	X	X	X			X	X		0 s	
I>>	X	X	X	X	X	X			X	X		$1.0 \times I_N$	
$t_{I>>V}/t_{I>>R}$	X	X	X	X	X	X			X	X		0.03 s	
RCA			X	X		X				X		49 °	
3pha/e-n/1:1					X	X	X					3 pha	
U_E					X	X	X					1V/2V/5V	
$I_{E>}$		X	X		X	X	X	X	X	X	X	$0.01 \times I_N$ (E) $0.1\% I_N$ (X)	
WARN/TRIP		X	X		X	X	X	X				TRIP	
CHAR I_E		X	X					X	X	X	X	DEFT	
$t_{IE>V}/t_{IE>R}$		X	X		X	X	X	X	X	X	X	0.05 s (ER/XR) 0.04 s (others)	
0s / 60 s (earth)		X	X					X	X	X	X	0 s	
$I_{E>>}$		X	X		X	X	X	X	X	X	X	$0.01 \times I_N$ (E) $0.1\% I_N$ (X)	
$t_{IE>>V}/t_{IE>>R}$		X	X		X	X	X	X	X	X	X	0.05 s (ER/XR) 0.04 s (others)	
SIN/COS					X	X	X					SIN	
SOLI/RESI									X	X	X	SOLI	
t_{CBFP}	X	X	X	X	X	X	X	X	X	X	X	0,1 s	
50/60 Hz	X	X	X	X	X	X	X	X	X	X	X	50 Hz	
Indication activation	X	X	X	X	X	X	X	X	X	X	X	FLSH	
RS 485 / Slave-address	X	X	X	X	X	X	X	X	X	X	X	1	
Baud-Rate*	X	X	X	X	X	X	X	X	X	X	X	9600	
Parity-Check*	X	X	X	X	X	X	X	X	X	X	X	even	
Blocking function	X	X	X	X	X	X	X	X	X	X	X		
Assignment of the output relays	X	X	X	X	X	X	X	X	X	X	X		
Failure memory	X	X	X	X				X	X	X	X		

* only Modbus Protocol

All settings must be checked at site and should the occarision arise, adjusted to the object/item to be protected.

Setting of code jumpers

Code jumper	J1		J2		J3	
	Default setting	Actual setting	Default setting	Actual setting	Default setting	Actual setting
Plugged						
Not plugged	X				X	

Assignment of the output relays:

Function	Relay 1		Relay 2		Relay 3		Relay 4	
	Default setting	Actual setting	Default setting	Actual setting	Default setting	Actual setting	Default setting	Actual setting
$I_{>}$ alarm (V)			X					
$t_{>}$ tripping (V)	X							
$I_{>}$ alarm (R)*			X					
$t_{>}$ tripping (R)*	X							
$I_{>>}$ alarm (V)					X			
$t_{>>}$ tripping (V)	X							
$I_{>>}$ alarm (R)*					X			
$t_{>>}$ tripping (R)*	X							
$I_{E>}$ alarm (V)							X	
$t_{IE>}$ tripping (V)	X							
$I_{E>}$ alarm (R)*							X	
$t_{IE>}$ tripping (R)*	X							
$I_{E>>}$ alarm (V)							X	
$t_{IE>>}$ tripping (V)	X							
$I_{E>>}$ alarm (R)*							X	
$t_{IE>>}$ tripping (R)*	X							
t_{CBFP} tripping								

* only relays with directional function

(V) = advance direction

(R) = reverse direction

Assignment of the blocking function:

Function	Default setting		Actual setting	
	Blocking	Not blocking	Blocking	Not blocking
I>		X		
I>>	X			
I _S		X		
I _{ES}		X		
T _{CRFP}		X		

This technical manual is valid for software version:

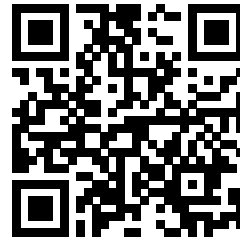
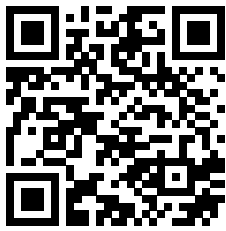
D01-8.10 (MRI1-ER; -IER; -IRER)
 D20-2.00 (MRI1-XR; -IXR; -IRXR)
 D24-1.00 (MRI1-X; -IX; -IXR)
 D00-8.10 (MRI1; I; E; IE; IR; SR; -IRE; -ISR; -IRSR)

Modbus-Version-number:

D51-1.00 (MRI1-ER-M; -IER-M; -IRER-M)
 D70-1.00 (MRI1-XR-M; -IXR-M; -IRXR-M)
 D74-1.00 (MRI1-X-M; -IX-M; -IXR-M)
 D50-1.10 (MRI1-M; I-M; E-M; IE-M;
 -IR-M; SR-M; -IRE-M; -ISR-M; -IRSR-M)

HighTECH Line

https://docs.SEGelectronics.de/mri1_ie
<https://docs.SEGelectronics.de/mr>



SEG Electronics GmbH reserves the right to update any portion of this publication at any time. Information provided by SEG Electronics GmbH is believed to be correct and reliable. However, SEG Electronics GmbH assumes no responsibility unless otherwise expressly undertaken.



SEG Electronics GmbH
Krefelder Weg 47 • D-47906 Kempen (Germany)
Postfach 10 07 55 (P.O.Box) • D-47884 Kempen (Germany)
Telephone: +49 (0) 21 52 145 1

Internet: www.SEGelectronics.de

Sales
Telephone: +49 (0) 21 52 145 331
Fax: +49 (0) 21 52 145 354
E-mail: info@SEGelectronics.de

Service
Telephone: +49 (0) 21 52 145 614
Fax: +49 (0) 21 52 145 354
E-mail: info@SEGelectronics.de

SEG Electronics has company-owned plants, subsidiaries, and branches, as well as authorized distributors and other authorized service and sales facilities throughout the world.

Complete address / phone / fax / email information for all locations is available on our website.